

Machine truxure™

Pumping machine control solutions
for Industry & Infrastructure

Catalogue
2012

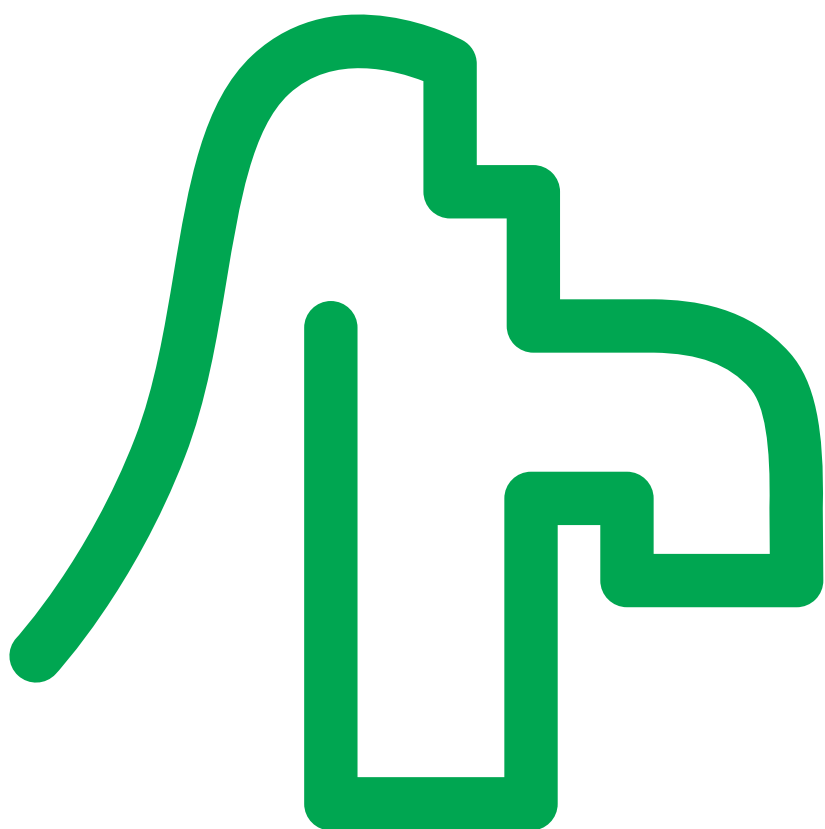

Schneider
 Electric



Machine Struxure™

Improve your pumping system & business performance

Water & wastewater, commercial buildings, industry or irrigation - Whatever your focus. In order to increase customer satisfaction you must supply machines which are more safe, energy efficient, reliable, at a reduced cost and shorter lead-time.

Your choice of Control Solutions is now, more than ever, a determining factor in distinguishing yourself at each stage, from the design and development to implementation and maintenance of the machine

Your Pumping solutions must be:

- > Reliable
- > Energy efficient
- > Innovative and adaptable
- > Open
- > Environment compliant

The requirements of a competitive market:

- > Quicker time to market
- > Optimized machines
- > Reduce maintenance cost
- > Compliance with worldwide standards
- > Worldwide services and support

To meet this demand, Schneider Electric offers MachineStruxure™, automation solutions, which help Machine Builders to quickly design pumping machines that are optimized regarding costs and energy efficiency, whilst maximising their performance throughout the service life of the machine. MachineStruxure™ solutions for pumping applications allow you to:

- > Reduce your machine's time-to-market with predefined "Tested, Validated, and Documented Architectures" and comprehensive pumping library
- > Improve machine performance with innovative automation technology and expert pumping application functions, supplemented by advanced drive technology, in order to increase energy efficiency while reducing maintenance and improving reliability
- > Gain a competitive advantage and optimize the global cost of your machine: from design to maintenance, we are ready to help you wherever you are through our worldwide network of training, solution design and delivery centres, after-sales services, and pumping control experts

General contents

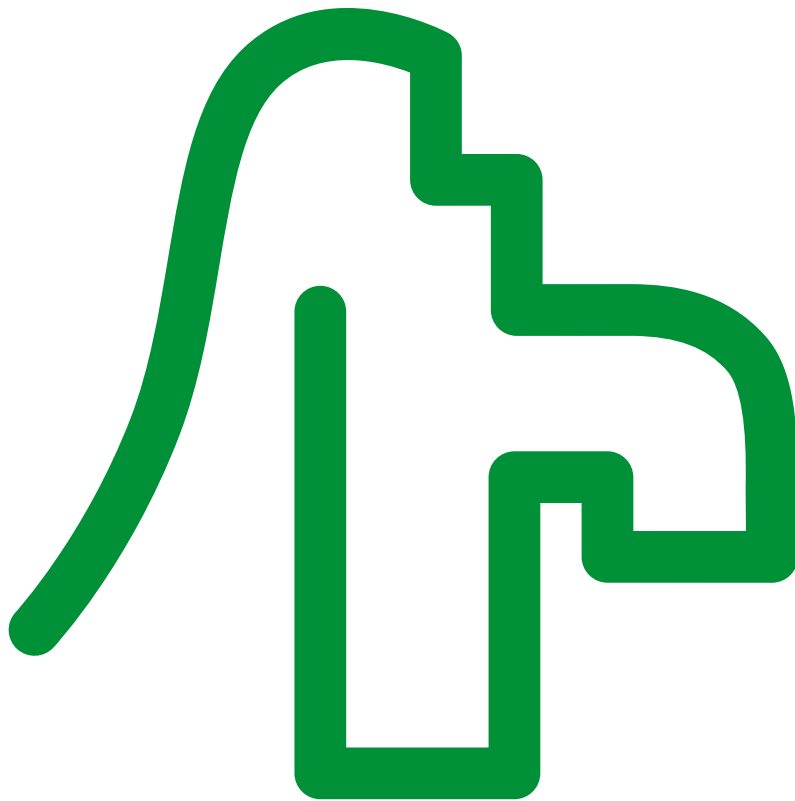

Solution Overview	1
SoMachine software & Application Function Blocks library	2
Hardware control platform.....	3
Communication	4
Associated offers.....	5

chapter 1

Pumping Control Solutions

Solution overview



Pumping Control Solutions information are available on:
www.schneider-electric.com/pumping

- **Reduce your Pumping application’s time-to-market**
 - Reach 100 % of flexibility and optimisation using an innovative flexible control system 1/2
 - Use the solid base of Tested, Validated and Documented Architectures and function blocks dedicated to Pumping applications 1/3
 - Reduce the complexity of your program design and implementation times with SoMachine software suite 1/3
 - Customize your machines and upgrade them without increasing the design phases or costs 1/3
- **Application solutions**
 - Booster Multi-drive 1/4
 - Booster Single drive 1/5
- **Application Function Blocks**
 - Pump stage and De-Stage 1/6
 - Booster working mode 1/7
 - Auxiliary Pump 1/8
 - Cavitation protection 1/9
 - Friction loss 1/10
 - PID 1/11
- **Energy Efficiency**
 - 4 steps to ensure immediate results when optimizing the energy consumption of your pumping machine 1/12
 - Increase performance whilst reducing energy consumption of your pumping machine 1/13
- **Develop your business**
 - Service and support that are behind you all the way 1/14
 - Gain a competitive advantage in each stage of your machine 1/15
 - A complete pumping setup to validate your Pumping application 1/15
 - World-class monitoring service for you and your customers 1/16
 - Easy and hassle-free remote monitoring solution 1/17
 - Your one-stop shop from simple control systems to global automation solutions 1/18

Pumping Control Solutions

Solution Overview

Reduce your Pumping application's time-to-market

1

How can you reduce the time-to-market of your booster?

Reach 100 % of flexibility and Optimization using an innovative flexible control system

Pumping equipment today needs to be ever more efficient and reliable. To enjoy a much more smart control, traditional relays and electronic boards solutions with "traditional controllers" are being replaced with smart control systems with integrated functionalities for pumping and energy efficiency. As a consequence the mix in development costs have changed, demanding an even greater emphasis on design efficiency. Flexibility is the key in providing a control solution that meets perfectly your requirements whilst reducing your costs.

That's why MachineStruxure™ solution incorporates a Flexible Machine Control Platform system that focuses on embedded intelligence in its products and a unique software platform that provides a single, easy to use environment for developing, programming and commissioning the machines.

1 software environment + Pumping application function blocks library

> Simplify machine programming & commissioning with SoMachine suite



Multiple hardware control platforms

> Embedded Intelligence where it is needed

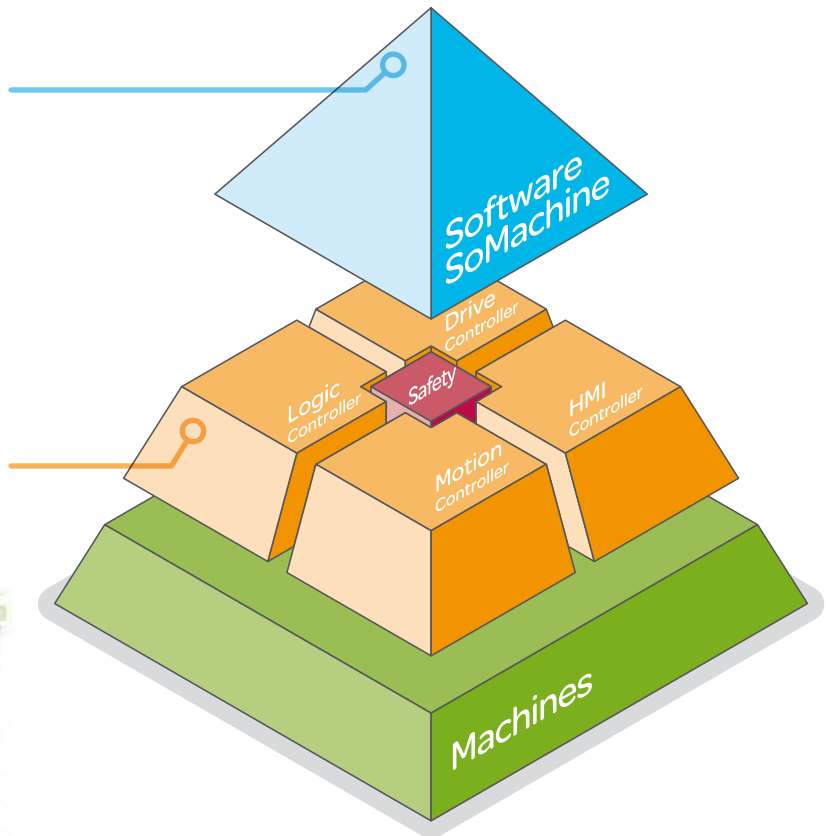
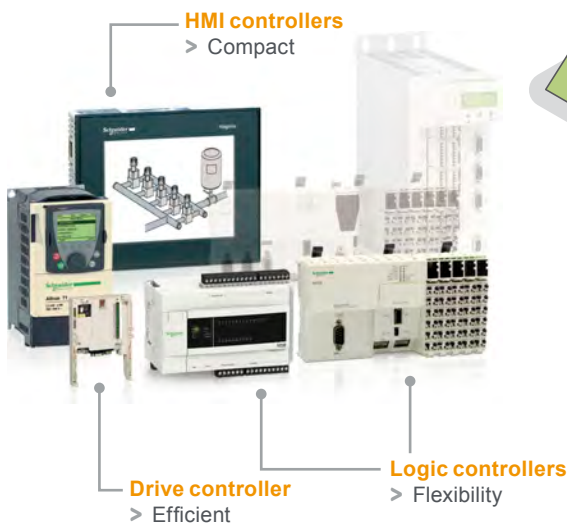

+ With MachineStruxure™ achieve **100%** flexibility and optimization of your machines



- > Suggested equipment lists
- > **Tested:** to ensure that they function in each possible configuration
- > **Validated:** full functional compatibility of devices
- > **Documented:** a complete System User Guide



Pumping solutions examples

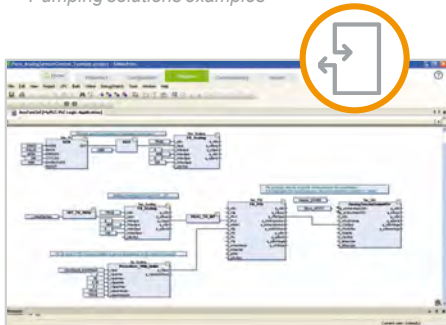

Our pre-programmed function blocks offer speed in development for your applications. they can be configured with a simple copy and paste. They can be quickly implemented in the machine programs, reducing the effort required to create an application and reducing the risk of errors.

MODBUS

Ethernet



Wi-Fi-Bluetooth

MachineStruxure™ solutions use open standards through IEC languages, open networks and transparency through FDT/DTM technology, providing you time savings.

Use the solid base of Tested, Validated and Documented Architectures and function blocks dedicated to pumping applications

Based upon flexible and scalable hardware platforms and a comprehensive single software suite, MachineStruxure™ proposes Tested, Validated and Documented Architectures (TVDA) with pumping application function block (AFB) libraries.

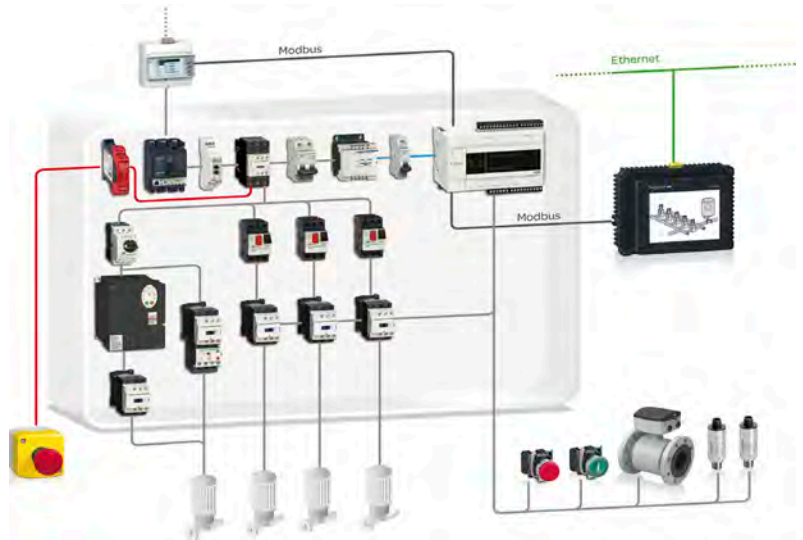

Reduce the complexity of your program design and implementation times with SoMachine software suite

Due to a rich set of templates and libraries:

- > Programming and template libraries
- > Graphical objects
- > Alarm management
- > Application Function Blocks (AFB) library
- > Application examples

Customize your machines and upgrade them without increasing the design phases or costs

Simple customization and integration

- > With our existing function blocks you can simply modify, reuse or create your own
- > Easily integrate your own systems into our architectures utilizing FDT/DTM technology

Compliance with global standards for maximum flexibility and durability

- > SoMachine and the control platforms support the 6 programming languages (FBD, ST, SFC, LD, IL, CFC) and is compliant with IEC 61131-3
- > Integrated open and standard networks in devices
- > SoMachine software combined with our control platforms allow you simply upgrade your architectures

Remote connection

- > Ethernet connection allows remote connection between the pump and the ground with Wi-Fi
- > Bluetooth connection available as well on Controller port

+ Save up 50% of design and implementation time

Application solutions

Booster Multi-drive

- > Simplified cabling
- > Phase control functionality integrated in the drive
- > Monitor Energy Efficiency through a large range of Power Meter and easy-to-use Application function blocks
- > Best Efficiency with the drive technology additional up to 20% Energy saving
- > Advanced pumps protection performed by the drive
- > All information available on HMI screen with ready to use pages matching application example
- > Supports fixed speed pumps in addition to variable speed pumps

With logic controller Modicon M238

Powerful solution for machines requiring maximum flexibility and scalability plus higher level of functionality

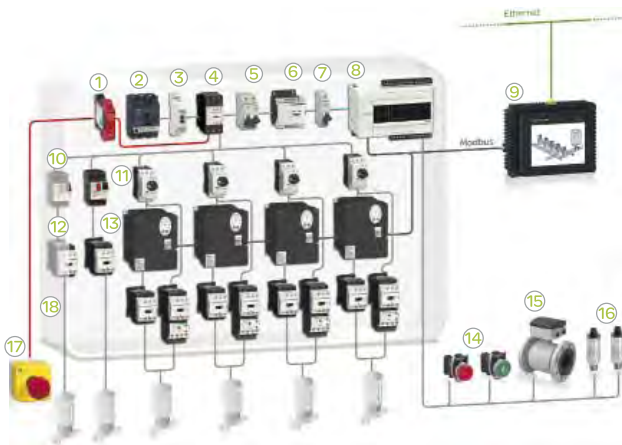

Solution breakdown

- 1 Safety module **Preventa XPS (1)**
- 2 Circuit breaker **Compact NSX (1)**
- 3 Phase sequence relay **Zelio control (1)**
- 4 Contactor **TeSys D (1)**
- 5 Modular Circuit breaker **C60L-MA (1)**
- 6 Switch mode power supply **Phaseo (1)**
- 7 DC Circuit breaker **C60L-DC (1)**
- 8 Logic controller **Modicon M238 (See chapter 3)**
- 9 Display **Magelis HMI STU (1)**
- 10 Circuit breaker **TeSys GV2M (1)**
- 11 Magnetic Circuit breaker **TeSys GV2L (1)**
- 12 Contactor **TeSys D (1)**
- 13 Variable speed drive **Altivar 212 (1)**
- 14 Control & Signalling units **Harmony XB4/XB5 (1)**
- 15 Flow meter *(Third-party product)*
- 16 Pressure sensor **OsiSense XMLP (1)**
- 17 Emergency stop push button **Harmony XALK (1)**
- 18 Enclosure **Spacial 3D ACM & AP (1)**

With HMI controller Magelis SCU

Higher level of functionality with an cost effective controller with built-in HMI for scalable systems

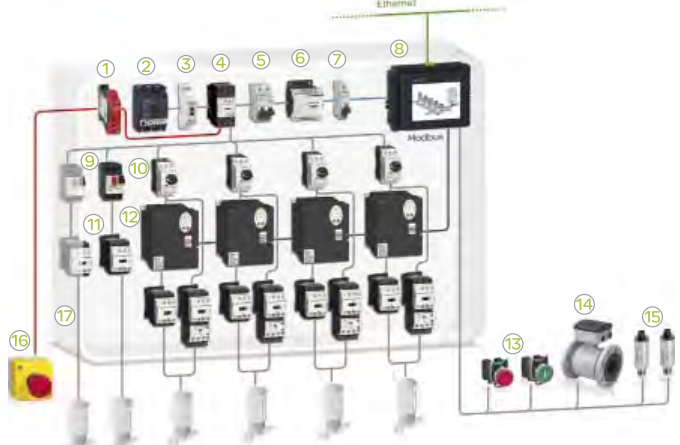

Solution breakdown

- 1 Safety module **Preventa XPS (1)**
- 2 Circuit breaker **Compact NSX (1)**
- 3 Phase sequence relay **Zelio control (1)**
- 4 Contactor **TeSys D (1)**
- 5 Modular Circuit breaker **C60L-MA (1)**
- 6 Switch mode power supply **Phaseo (1)**
- 7 DC Circuit breaker **C60L-DC (1)**
- 8 HMI controller **Magelis SCU (1)**
- 9 Circuit breaker **TeSys GV2M (1)**
- 10 Magnetic Circuit breaker **TeSys GV2L (1)**
- 11 Contactor **TeSys D (1)**
- 12 Variable speed drive **Altivar 212 (1)**
- 13 Control & Signalling units **Harmony XB4/XB5 (1)**
- 14 Flow meter *(Third-party product)*
- 15 Pressure sensor **OsiSense XMLP (1)**
- 16 Emergency stop push button **Harmony XALK (1)**
- 17 Enclosure **Spacial 3D ACM & AP (1)**

(1) Please consult the chapter 5 - Associated offers, or our web site: www.schneider-electric.com

Booster Single drive

- > Drive connected to the same pump
- > Cost effective & simple solution for small booster

+

- > Save 50% in design and installation time
- > Modularity and flexibility
- > Energy efficiency
- > Openness Plug & play connectivity

With drive controller Altivar IMC

An open and 30% less costly system than a PLC - based solution: without any compromise on functionalities

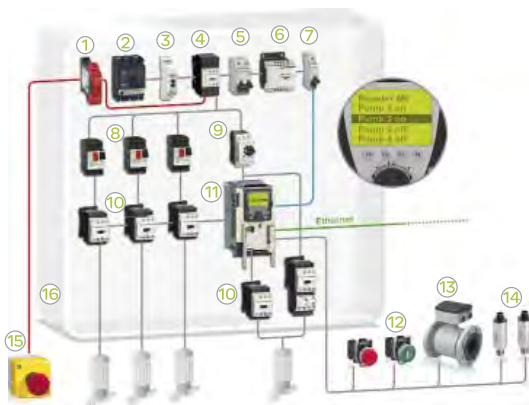

Solution breakdown

- 1 Safety module **Preventa XPS (1)**
- 2 Circuit breaker **Compact NSX (1)**
- 3 Phase sequence relay **Zelio control (1)**
- 4 Contactor **TeSys D (1)**
- 5 Modular Circuit breaker **C60L-MA (1)**
- 6 Switch mode power supply **Phaseo (1)**
- 7 DC Circuit breaker **C60L-DC (1)**
- 8 Circuit breaker **TeSys GV2M (1)**
- 9 Magnetic Circuit breaker **TeSys GV2L (1)**
- 10 Contactor **TeSys D (1)**
- 11 Drive controller **Altivar IMC + Altivar 61 (See chapter 3)**
- 12 Control & Signalling units **Harmony XB4/XB5 (1)**
- 13 Flow meter *(Third-party product)*
- 14 Pressure sensor **OsiSense XMLP (1)**
- 15 Emergency stop push button **Harmony XALK (1)**
- 16 Enclosure **Spacial 3D ACM & AP (1)**

With logic controller Modicon M238

Simple solution for machines requiring a minimum flexibility and scalability with a good level of functionality

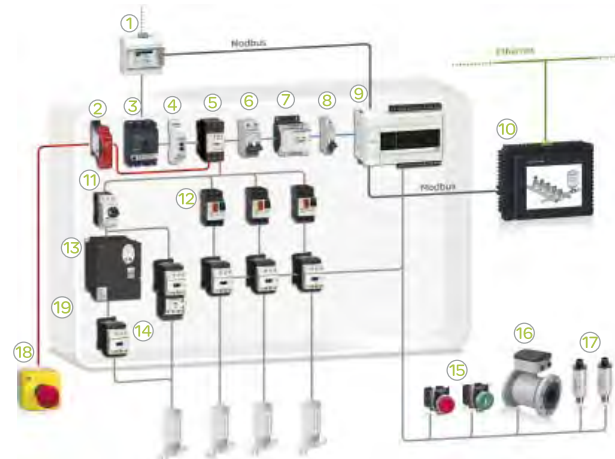

Solution breakdown

- 1 PowerMeter **(1)**
- 2 Safety module **Preventa XPS (1)**
- 3 Circuit breaker **Compact NSX (1)**
- 4 Phase sequence relay **Zelio control (1)**
- 5 Contactor **TeSys D (1)**
- 6 Modular Circuit breaker **C60L-MA (1)**
- 7 Switch mode power supply **Phaseo (1)**
- 8 DC Circuit breaker **C60L-DC (1)**
- 9 Logic controller **Modicon M238 (See chapter 3)**
- 10 Display **Magelis HMI STU (1)**
- 11 Magnetic Circuit breaker **TeSys GV2L (1)**
- 12 Circuit breaker **TeSys GV2M (1)**
- 13 Variable speed drive **Altivar 212 (1)**
- 14 Contactor **TeSys D (1)**
- 15 Control & Signalling units **Harmony XB4/XB5 (1)**
- 16 Flow meter *(Third-party product)*
- 17 Pressure sensor **OsiSense XMLP (1)**
- 18 Emergency stop push button **Harmony XALK (1)**
- 19 Enclosure **Spacial 3D ACM & AP (1)**

(1) See chapter 5 - Associated offers. Or please consult on our web site: www.schneider-electric.com

Other possibility for Single drive, multi lead

- > Energy efficient solution, flexible
- > Drive is used to start successively all pumps

Pump stage and De-Stage

To optimize booster system operation by switching pumps

The pump stage and De-Stage function switch a combination of fixed and variable speed pumps to maintain a constant pressure in a booster system.

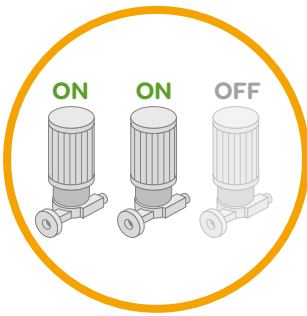

Benefits

- > Maintains the required pressure by performing switching between the pumps available in the system.
- > Making the system energy efficient by making the operational combination of pumps in such a way that the pumps operated by drives are given priority.
- > To ensure a smooth operation, checking the availability of the pumps and in case of a faulted pump detected, change over to next available pump.

Operating principle

The main objective of the function is to perform switching of the multiple pumps to maintain a pre-defined pressure in the booster system. The flow and pressure are measured through sensors while the setpoints are entered from the HMI. Using intelligent algorithms, the function is managing the switching by defining priorities to the pumps by detecting availability and principle of energy optimization.

Characteristics

- > Capable of maintaining required pressure in the booster system using an energy efficient algorithm selecting the optimized state of pumps operation.
- > Switching of pumps is based upon the principle to assign higher priority to variable speed pumps and pumps with less number of operating hours.
- > With an intelligent algorithm, the function switches next available pump in operation, in case of detection of a faulty pump.

These AFBs are provided in the library to realize this function

AFB	Function name in the Library	AFBs to perform the function
Pump stage and De-Stage	Pump stage control	PumpPid PumpPidStag

Typical applications

- > Booster pumping system consisting of multiple pumps

Typical architecture

- > Optimized Pumping compact / **Hardwired** / Drive controller / **Altivar IMC**
- > Optimized Pumping compact / **Modbus** or **Hardwired** / Logic controller / **Modicon M238** and **Magelis HMI**
- > Optimized Pumping compact / **Modbus** or **Hardwired** / HMI controller / **Magelis SCU**

Booster working mode

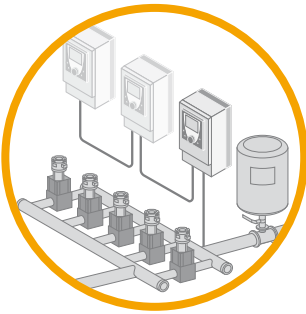

To operate the booster system in an optimized method by selecting appropriate working mode of the pumps

The function is capable of selecting “single drive” or “multi drive” as operating mode in a booster system.

Definition & Benefits

Multi-drive:

- > Definition: In this mode, each pump in the system is connected to an individual drive.
- > Main advantages: This type of arrangement provides the best energy efficient systems along with higher level of pump protection. Easy to maintain systems.

Single-drive, multi lead:

- > Definition: In this mode, a single drive is used to start the first pump in the system. The selection of pump is based upon operating hours /fault status of the pump or the user-defined priority.
- > Main advantages: These types of arrangements are cost effective and more energy efficient.

Single-drive, single lead:

- > Definition: In this mode, a single drive is used to start the only one pump in the system and there is no switching of drives to other pump.
- > Main advantages: These types of arrangements are cost effective.

Operating principle

The main task of this function is to enable the pump packager to select the best working mode for the booster system. By selecting multi lead systems, multiple pumps, connected to drives or contactors, can be controlled to perform the switching different pumps to operate them in most optimized manner. Switching is based upon pressure, operating hours and available pumps in the system.

- > The single-drive, multi lead systems can select the pump to be connected and started with the single drive present in the system. Subjected to the pressure requirements, the other fixed speed pumps are started accordingly. In case of fault and the stoppage of the system, the drive will be connected to the first available pump based upon operating hours / fault status of the pump or the user-defined priority.
- > In single-drive, single lead systems the single drive in the system is connected to only one pump and there is no switching of the drive to other pumps in the system. Subjected to the pressure requirements, the other fixed speed pumps are started by DOL.

Characteristics

- > Switching of the pumps is performed to operate the pumps in most optimized and energy efficient operating way.
- > The function detects the next available pump on the basis of operating hour, fault condition and pressure requirement.
- > The function is capable of bypassing the drives in case of fault.
- > Switching value can be set from the HMI.

Typical applications

- > Booster pumping system consisting of multiple pumps

Typical architecture

- > Optimized Pumping compact / **Hardwired** / Drive controller / **Altivar IMC**
- > Optimized Pumping compact / **Modbus** or **Hardwired** / Logic controller / **Modicon M238** and **Magelis HMI**
- > Optimized Pumping compact / **Modbus** or **Hardwired** / HMI controller / **Magelis SCU**

This AFB is provided in the library to realize this function

AFB	Function name in the Library	AFBs to perform the function
Booster working mode	Device Switching Control[Basic]	DevSwcCtrlB

Auxiliary Pump

Operating auxiliary speed pumps in a booster system

The auxiliary pump control function is controlling the auxiliary pump to maintain the water pressure during sleep mode (night) with monitoring of alarms.

Benefits

- > Detect condition where an auxiliary pump needs to be operated.
- > Ensure optimized pump efficiency by switching auxiliary pumps to maintain pressure in the system.
- > Increase the energy efficiency of the system by operating smaller pumps to maintain lower flow.

Operating principle

The main task of this function is to maintain the pressure during low flow situations, like in the night (sleep-mode), in a water distribution system. The sleep mode is detected by the PID-stage/de-stage function. By detecting a low pressure, the system sends command to start the auxiliary pump. Similarly, the sleep modes ends by detecting pressure dropping below the required limit.

Characteristics

- > With the setpoints and actual pressure values, the function activates the auxiliary pump.
- > The function detects the end of the sleep mode with the help of the flow value or the pressure value and limit set-points. If the flow overruns the limit, the function resets the sleep mode state.
- > The function is capable of displaying the operating hour value.

This AFB is provided in the library to realize this function

AFB	Function name in the Library	AFBs to perform the function
Auxiliary Pump	Auxiliary Pump Control	AuxPumpCtrl

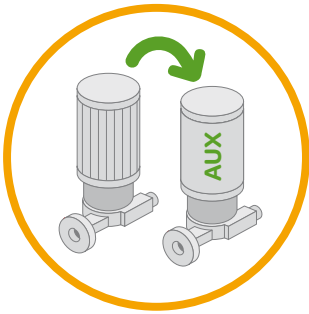

Typical applications

- > Booster pumping system consisting of multiple pumps

Typical architecture

- > Optimized Pumping compact / **Hardwired** / Drive controller / **Altivar IMC**
- > Optimized Pumping compact / **Modbus** or **Hardwired** / Logic controller / **Modicon M238** and **Magelis HMI**
- > Optimized Pumping compact / **Modbus** or **Hardwired** / HMI controller / **Magelis SCU**

Cavitation protection

To monitor and protect the pump against cavitations

This function avoids the operation of the pump in the cavitation situation by stopping the pump.



Benefits

- > Ensures a longer operating life of the pump by ensuring that the pump is not operating in cavitation.
- > Generates alarms in case of detection of the cavitation in the system.
- > With the adaption of the setpoints, this function ensures that the pumps are operating in optimized state.

Operating principle

The main task of this function is to avoid the operation of the pumps in a cavitation situation. By detecting of a cavitation situation, the function immediately stops the pumps. The function is accomplished by reducing the pressure set-point /flow of the system. The function, after completing the cavitation task and resetting the alarm, checks the suction pressure. If the suction pressure is within the permissible limits than the function starts the operation of pump in normal mode.

Characteristics

- > Detection of abnormality in pressure using the actual suction feedback pressure value.
- > Activating algorithms to adjust setpoints to avoid a cavitation situation.
- > Using a limit switch function, the function avoids toggling of the cavitation mode.
- > Capable of generating alarms by detecting of a cavitation situation.

This AFB is provided in the library to realize this function		
AFB	Function name in the Library	AFBs to perform the function
Cavitation protection	Cavitation Protection	CavtProt

Typical applications

- > Booster Pumping system consisting of single or multiple pumps

Typical architecture

- > Optimized Pumping compact / **Hardwired** / Drive controller / **Altivar IMC**
- > Optimized Pumping compact / **Modbus** or **Hardwired** / Logic controller / **Modicon M238** and **Magelis HMI**
- > Optimized of Pumping compact / **Modbus** or **Hardwired** / HMI controller / **Magelis SCU**

Friction loss

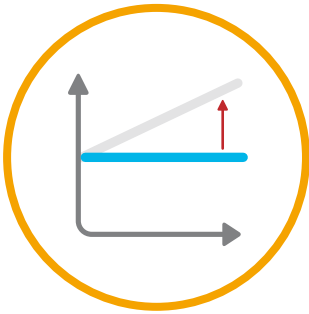

These AFBs are provided in the library to realize this function		
AFB	Function name in the Library	AFBs to perform the function
Friction Loss	Setpoint handling	CompSpB CompSpFlow

To ensure a linear pressure in the booster system

This function compensates the friction lost by adapting the pressure setpoint according to the number of running pumps or the flow value (optional) in the discharge side.

Benefits

- > Ensures a longer operating life of the pump by ensuring a linear pressure in the system.
- > Generates alarms in case of detection of the abnormality in suction pressure curve.
- > With the adaption of the pressure setpoints, this function ensures that the pumps are operating in optimized state.

Operating principle

- > Ideal pressure can be maintained either on the basis of flow or setpoints of each pump in the system. For flow, the function adapts the set-point to the system curve with the help of the actual flow value using actual flow value and setpoint. Both absolute and percentage values can be used. The minimal setting (two points) to use this function are:
 - > 1. The raised value in percent (% to increase the standard set-point) or the absolute value of the set-point to reach the set-point value on the highest and farthest point of the system in case of minimal flow. The standard value of this point is zero (relative) or equal to the set-point (absolute).
 - > 2. The raised value in percent (% to increase the standard set-point) or absolute value of the set-point to reach the set-point value on the highest and farthest point of the system in case of maximal flow. The value of this point is higher than zero (relative) or greater than the set-point (absolute.).
- > The results of this measurement are minimum two correction values in percent or absolute values and its corresponding flow values.

In case of adaptation of the setpoints of the pumps, the function adapts the set-point depending on the number of used pumps and the moment of the stage change.

Characteristics

- > Detection of abnormality in pressure in the system.
- > Execution of algorithms to maintain the pressure using flow or setpoints management of the pumps.
- > Capable of generating alarms by detecting abnormality in pressure in the system.

Typical applications

- > Booster Pumping system consisting of single or multiple Pumps

Typical architecture

- > Optimized Pumping compact / **Hardwired** / Drive controller / **Altivar IMC**
- > Optimized Pumping compact / **Modbus** or **Hardwired** / Logic controller / **Modicon M238** and **Magelis HMI**
- > Optimized Pumping compact / **Modbus** or **Hardwired** / HMI controller / **Magelis SCU**

PID

To maintain a constant pressure by adapting setpoints

The PID function adjusts the setpoint of the pumps to maintain a constant pressure in a booster system on the basis of flow and pressure.



Benefits

- > Maintains the required pressure by adjusting the setpoint.
- > Generates alarms in case of deviation of limits.
- > To ensure a smooth operation, by maintaining the setpoints curve by avoiding damping.

Operating principle

The main objective of this function is to generate the set-point for the VSD in the booster system. The flow and pressure are measured through sensors while the setpoints are entered from the HMI. Using intelligent algorithms, the function manages the setpoint using flow and pressure values as input and generating the outputs values in percentage. Alarms are generated in case of deviation of values with reference of defined limits.

Characteristics

- > Capable of calculating the cycle time.
- > Capable of limiting different attributes with corresponding set of values like error value for the I-part calculation, the control value.
- > Detection and display of alarms in HMI.

Typical applications

- > Booster Pumping system consisting of single or multiple Pumps

Typical architecture

- > Optimized Pumping compact / **Hardwired** / Drive controller / **Altivar IMC**
- > Optimized Pumping compact / **Modbus** or **Hardwired** / Logic controller / **Modicon M238** and **Magelis HMI**
- > Optimized Pumping compact / **Modbus** or **Hardwired** / HMI controller / **Magelis SCU**

This AFB is provided in the library to realize this function

AFB	Function name in the Library	AFBs to perform the function
PID	PumpPid	PumpPid

Pumping Control Solutions

Solution Overview

Energy Efficiency

1

Boost the energy efficiency of your pumping machines

4 steps to ensure immediate results when optimizing the energy consumption of your pumping machines

Improve time to market, reducing the overall cost of pumping machines whilst increasing their performances and adding innovations are everyday challenges for you. On top of this, your customers are increasingly asking you to design machines that require less energy.

For supporting energy savings and obtaining immediate results, we follow the 4 Energy Efficient principles adapted to the machine life cycle.

The approach is compliant with the guidelines in European standard EN 16001 and with the ISO 50001 "energy management system" which targets continuous improvement in the energy performance of every organization.

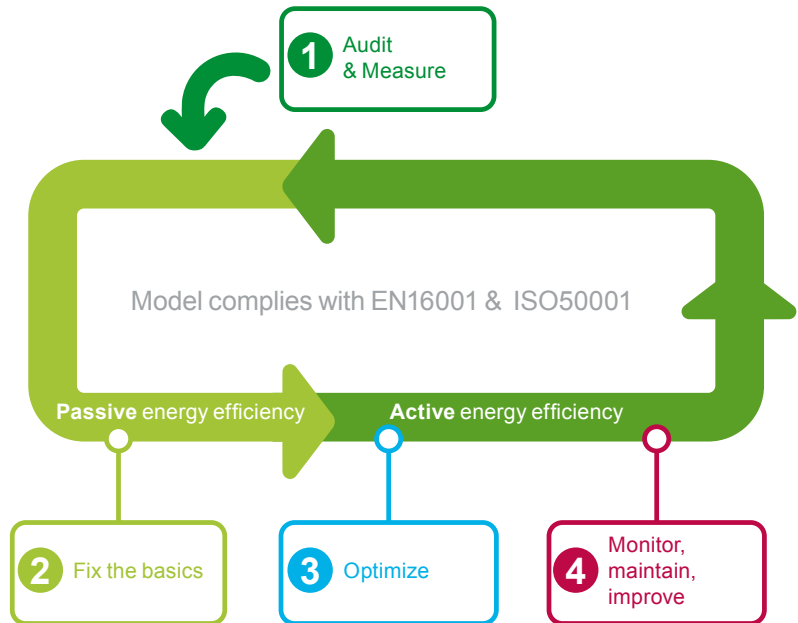

+

Machine Builder benefits

- > Improve the visibility of your machines' energy consumption
- > Detection of the "over-sized" equipments as these consumes more energy
- > Possible marketing argument to your customers with a real evidence of Energy savings

+

End customer benefits

- > Significant reductions in energy bills
- > Improved preventive maintenance for machines
- > Increased lifespan for motors and electronic equipment

Increase performance whilst reducing energy consumption of your pumping machine

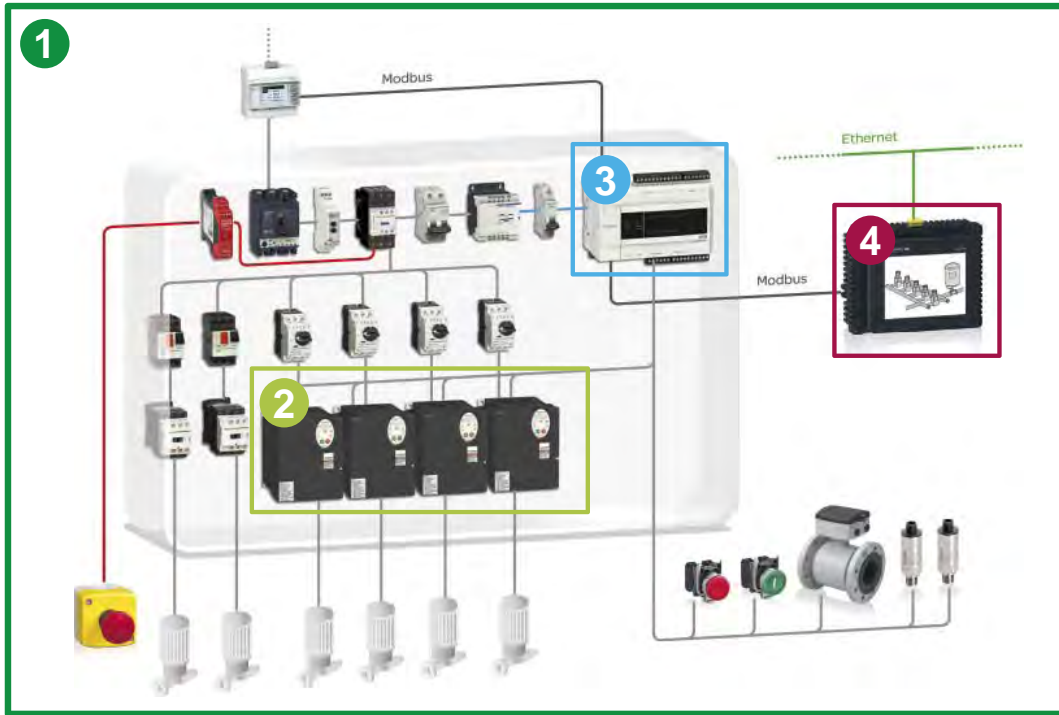

- 1 Audit & Measure** energy consumption with a Schneider Electric expert. They will identify devices with high energy consumption (pumps, motors, compressors etc.) and recommend potential savings.
- 2 Fix the basics** by selecting the appropriate motor, using servo-drives, improved cabinet thermal management etc.
- 3 Optimize** machines by using the energy efficiency function block libraries available in the SoMachine software suite, specifically designed for the various applications. Example: pumps, packaging, conveyors, etc
- 4 Monitor, maintain, improve.** The SoMachine software suite contains function blocks dedicated to collecting energy information from metering units and electronic equipment (variable speed drive, servomotor etc.). The information provided allows the dedicated function blocks to create indicators that are used to monitor the relevant information by correlating energy readings (active power, power, current etc.) with the machine's operational modes and production data. All of the indicators produced can be manipulated on-screen via predefined graphic objects supplied with SoMachine and Vijeo Designer.



1

How can you develop your business?

Service and support that are behind you all the way



Design

We find the best solution for your needs

- > Based on your needs, our Solution Application Experts and Application Design Experts (SAE/ADE) work out innovative technical solutions including
 - > co-engineering
 - > tests
 - > validation

We understand your pain points

- > Consulting

We execute the solution with a full service agreement

- > Our solution design and delivery centers (Flex-Centres) are committed to quality and results and provide:
 - > Project and program management
 - > Software and hardware engineering
 - > Tests, validation, and commissioning

We improve your team's competencies

- > In class training and on site training



Build

We ensure the delivery of your solution

- > Availability of components through a large worldwide network of distributors
- > Collaboration, management, and delivery through local partners
- > With Schneider Electric as your turnkey solution partner we include in our solutions:
 - > Project management and responsibility
 - > Engineered systems
 - > Third-party components management

We provide on-site services and support

- > Secondment of qualified personnel to deliver on-site engineering and technical services

We improve your service team's competencies

- > Service and commissioning training



Operate

We provide international sales and after-sales services for you and your customers

- Maintenance contracts
- Spares parts
- Repairs
- Normal and express deliveries
- Return of goods
- Service expertise:
 - > Error diagnosis and repair
 - > Environmental measurements (EMC, field bus, thermography, power quality analyses, etc.)
- Customer International Support (CIS) as a single point of contact:
 - > A network of 190 dedicated local country experts
 - > A web-based collaborative platform for efficient communication

We improve your customers' competencies

- In-class customer training and on-site training
- Customer service and commissioning training



Improve

Improve your machine ranges

- > Consulting

We improve your customer's machines in their production line

- > Audits
- > Services Expertises:
 - > Consultancy
 - > Retrofitting
- > Migration and upgrade
- > Training

Gain a competitive advantage in each stage of your machine

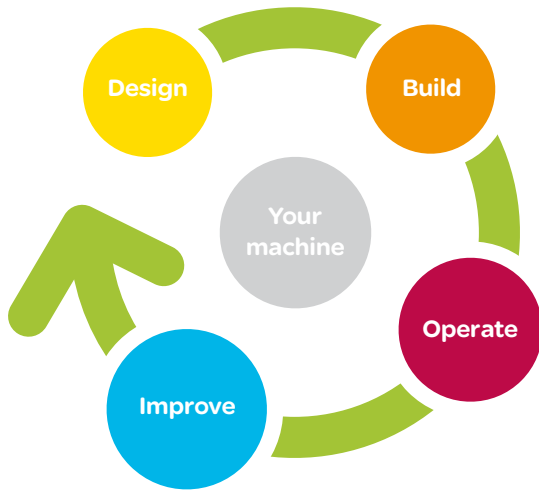

MachineStruxure™ solutions offer more than just products and architectures, you also get complete service and support at every stage of the product life cycle. Our unparalleled Pumping and control experts will help you minimise your global machine costs, increase sales and profitability, and deliver total customer satisfaction.

From design to commissioning to maintenance, we're ready to help you wherever you are with our worldwide network of training, solution design centres, distribution, and after-sales services.

A complete pumping setup to validate your Pumping application



Schneider Electric with its test units and expertise is able to simulate your installation as follows:

- > Select the architecture you want
 - > DOL, Single drive, Multidrive
 - > I/O control, Field-bus control
 - > Controllers & HMI
 - > Drives: Altivar 212 / Altivar 61
- > Select Hydraulic circuit
 - > Apply to hydraulic system for test case
- > Run complete test and Monitor
 - > Energy consumption
 - > Pressure, Flow, etc

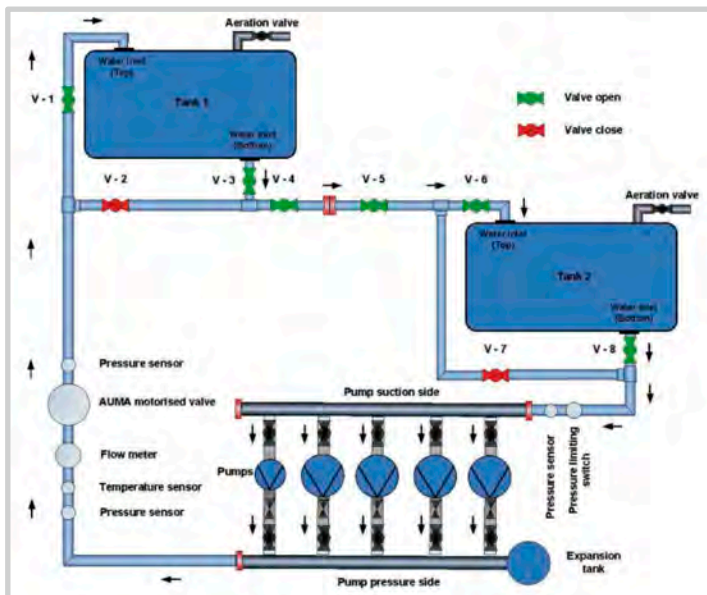
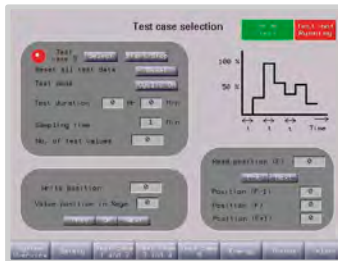

★ Connect with the experts

www.schneider-electric.com/pumping

> Increase your efficiency and competitiveness

1

How can you develop your business?

World-class monitoring service for you and your customers

The web-enabled capabilities of the controller offer associated with the OptiM2M™ solution for remote monitoring of machines allow an unrivalled quality of machine service for your customers, with reduced reaction times and attractive maintenance plans.



- > Improved control of remote equipment
- > Enhanced reaction time and productivity: detailed reports on equipment use (usage statistics, machine energy consumption, etc.)
- > New services for your established customers

Get constant visibility into your machine data

- > With OptiM2M, a web-based machine-to-machine monitoring application, you can remotely view and analyse incoming machine data. At any time, from anywhere in the world, using only your smart phone, laptop or another web-connected device with a browser.
- > OptiM2M users can harvest detailed, real-time equipment usage statistics, such as energy consumption of Pumping machines or usage statistics data access can be configured according to user type (equipment manager/owner/user, etc)

Why chose OptiM2M?

- > Grow your business and profits
 - > Develop sales with new customers and reach new markets
 - > Generate additional business with existing customers
 - > Develop your portfolio of smart services
- > Build your service provider image and customer satisfaction
 - > Maximise machine uptime and minimise after-sales intervention costs on site
 - > Achieve higher energy efficiency in true operating conditions
 - > Add value to your product with quality machine lifecycle support



Unrivalled machine services for you and your customers

Pumping Control Solutions

Solution Overview

How can you develop your business?

1

Easy and hassle-free remote monitoring solution

As a machine manufacturer you know that installing and deploying a communication solution is often easier on paper than in real life. That's why at Schneider Electric we are committed to making our machine-to-machine cloud solution as easy to configure as it gets.

The OptiM2M system is an install-and-go solution that delivers secured end-to-end wireless connectivity for machine-to-machine applications.

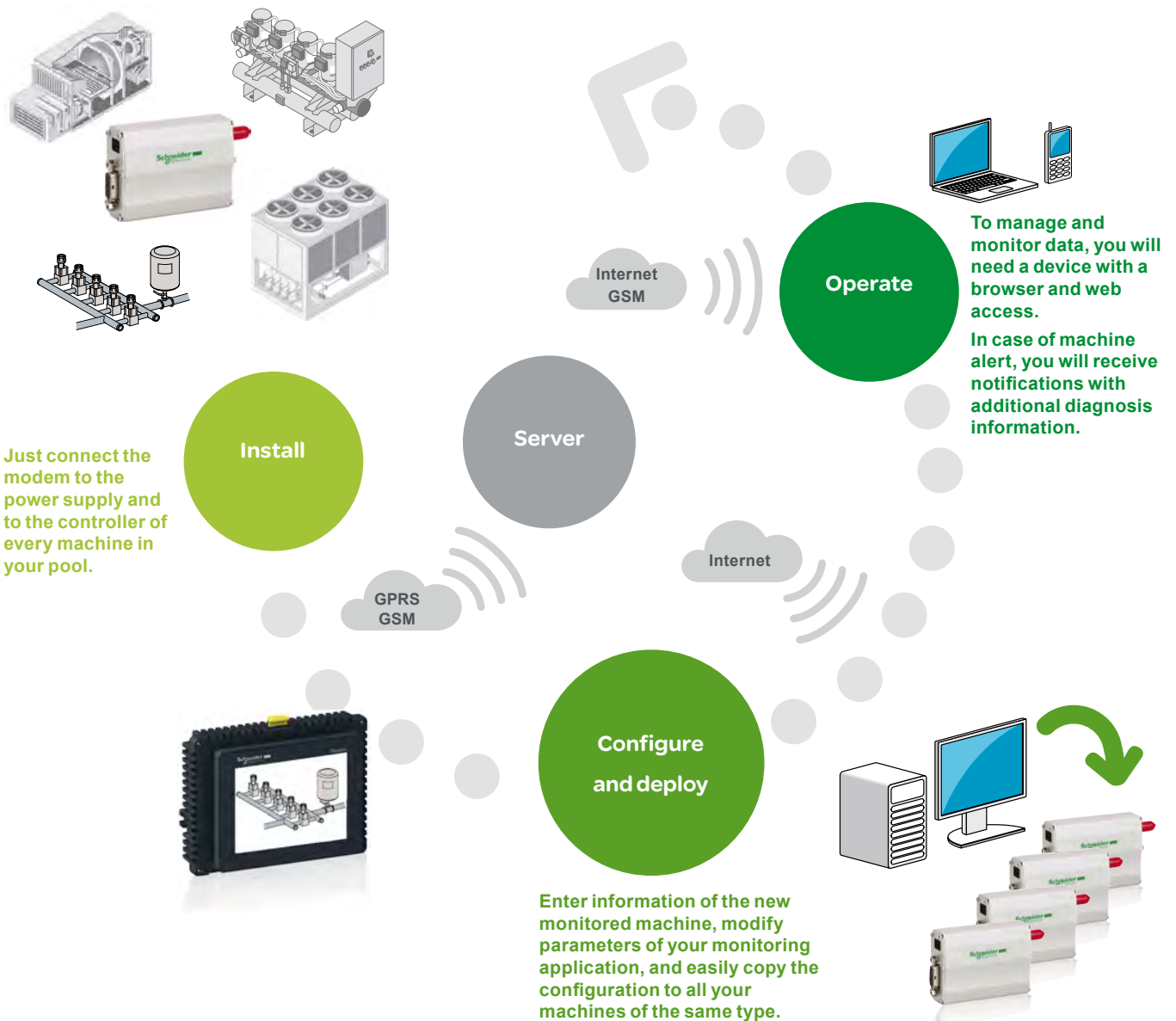

> Improve pumping machine management through remote control

1

How can you develop your business?

Your one-stop shop from simple control systems to global automation solutions

Schneider Electric is a world leader in automation. We help you benefit from the latest technologies that can turn your machines into a commercial success. From actuators to control systems, we have the solution that is suited to your specific needs

Motor control



> Maximum productivity and efficiency

HMI, control and dialog devices



> Intuitive and ergonomic design

Detection, communication, energy distribution, switching



> Assembly and supply systems, protection and control of LV power circuits, power meters, HVAC & R sensors, valves and actuators



- > wide range
- > simple to use
- > network opening
- > worldwide availability

Innovation dedicated to reduction of:

- > enclosure size
- > wiring time
- > installation time



Alliance Partners

Building on our open automation platforms and strategies, we work with strategic partners who compliment our capabilities in order to provide you with solutions that fully meet your business objectives. Within this collaboration partnership that can deliver the most complete and effective solution for your applications.

Pumping Control Solutions

Solution Overview

How can you develop your business?

1

Your one-stop shop from simple control systems to global automation solutions

From machine to plant, Schneider Electric provides a single, open and fully coherent system.

PlantStruxure™ architecture is Schneider Electric's comprehensive solution for industrial process control, whereas MachineStruxure™ architecture is dedicated to machine control.

Because both architectures are based on open standards and designed to be fully compatible, your machines can easily be integrated into your customers' factory processes. In addition, open standards allow your machines to evolve with your customers' changing requirements.

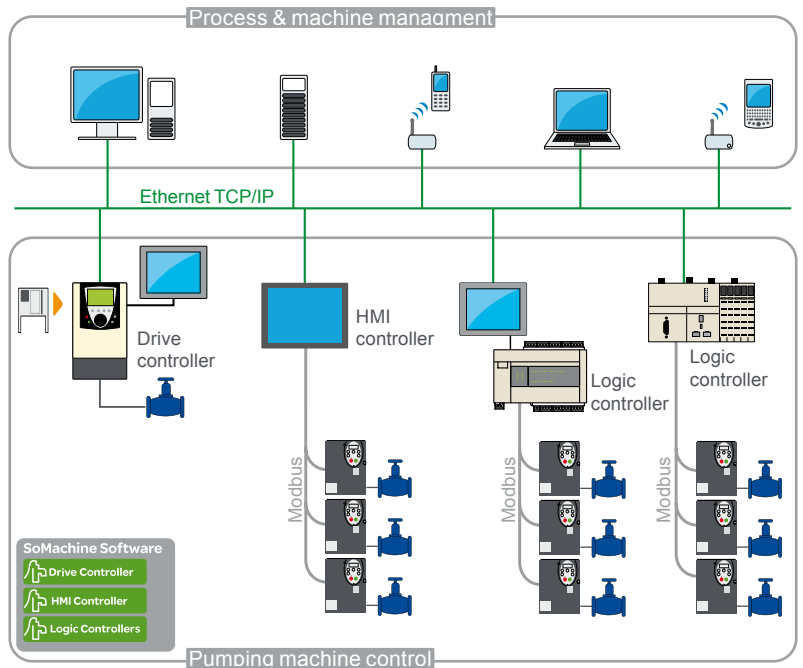

MachineStruxure™ architecture, one of the mainstays of EcoStruxure architecture

EcoStruxure™ system architecture enables the convergence of five key domains of our expertise: management of Power, Processes and Machines, the IT Room, Buildings, and Security.

EcoStruxure™ architecture takes multiple, siloed systems and adapts them to an integrated solution, reducing redundancy in equipment, software, and personnel.

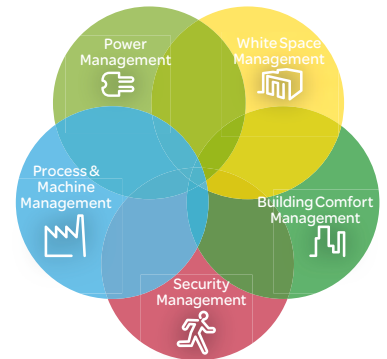

> From machine to plant, Schneider Electric provides a single, fully coherent system

chapter 2

SoMachine software suite



All technical information about products listed in this chapter
are available on www.schneider-electric.com

- **SoMachine software suite**
 - Visual graphic user interface 2/2
 - Learning centre 2/2
 - Projects management 2/2
 - Project properties 2/3
 - Configuration 2/3
 - Programming and debug..... 2/3
 - Commissioning 2/3
 - Documentation..... 2/3
 - Transparency 2/3
 - Dedicated OEM application libraries (AFB libraries) 2/3
 - Tested Validated Documented Architectures (TVDA) 2/3
- **SoMachine characteristics** 2/4
- **References** 2/5

SoMachine software suite

Simplify machine programming and commissioning

2



SoMachine software platform

Presentation

SoMachine is the Machine Builder solution software for developing, configuring and commissioning the entire machine in a single software environment, including logic, motion control, HMI and related network automation functions.

SoMachine allows you to program and commission all the elements in Schneider Electric's Flexible and Scalable Control platform, the comprehensive solution-oriented offer for Machine Builders, which helps you achieve optimized control solution for each machine's requirements.

Flexible and Scalable Control platforms include:

Controllers:

- HMI controllers: XBT GC, XBT GT/GK CANopen,
- Logic controllers for Solutions with AFB: Modicon M238S, Modicon M258S,
- Drive Controller: Altivar IMC for Solutions with AFB,
- I/Os range: Modicon TM2, Modicon TM5 and Modicon TM7 offers

HMI:

- Small Panels Magelis™ STO/STU
- Advanced Panels Magelis™ GH/GK/GT
- Optimum Advanced Panels Magelis™ GTO

SoMachine is a professional, efficient, and open software solution integrating Vijeo-Designer.

It integrates also the configuring and commissioning tool for motion control devices. It features the IEC 61131-3 languages, integrated field bus configurators, expert diagnostics and debugging, as well as outstanding capabilities for maintenance and visualisation.

SoMachine integrates tested, validated, documented and supported expert application libraries dedicated to applications in Pumping, Packaging, Hoisting and Conveying.

SoMachine provides you:

- One software package
- One project file
- One cable connection
- One download operation

Visual graphic user interface

Navigation within SoMachine is intuitive and highly visual. Presentation is optimized in such a way that selecting the development stage of the desired project makes the appropriate tools available. The user interface ensures nothing is overlooked, and suggests the tasks to be performed throughout the project development cycle. The workspace has been streamlined, so that only that which is necessary and relevant to the current task is featured, without any superfluous information.

Learning centre

From the home menu, the learning centre provides several tools to get started with SoMachine. An animated file explains briefly the SoMachine interface and concept. An e-learning allows to run a self-training about SoMachine. A third section gives access to several documented examples of simple coding with SoMachine. An intuitive and efficient online help is also available, guiding you to get the appropriate answer.

Projects management

The implemented project management principle allows to browse quickly through the existing projects getting the relevant information without the need to open them before selection.

The user can create a new project, starting from several means: using Tested Validated and Documented Architectures, using the provided examples, using an existing project or start with an empty project. There is quick access to the most recently-used projects.

There is as well a way to start a project from standard project taking advantages of a pre-configured program (task, library,)

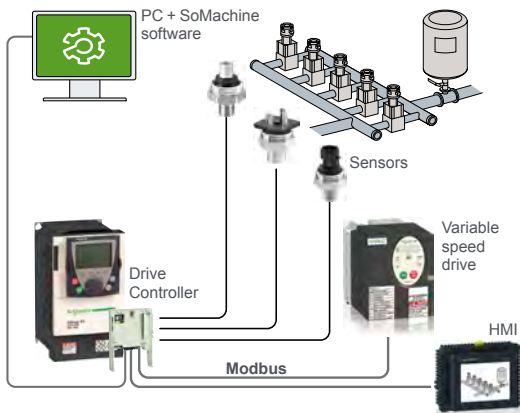

Software solution



Project management

SoMachine software suite

Simplify machine programming and commissioning

Project properties

For each project, the user has the option to define additional information, through simple forms. It's also possible to attach documents, a customer picture and a configuration picture.

Configuration

From the graphic user interface, the user can easily build his architecture and configure the devices of the architecture.

Description of the architecture

A graphic editor can be used to assemble the various elements easily by a simple drag & drop. A devices catalogue is displayed on the left of the screen. It is split into several sections: controllers, HMI, Miscellaneous and search.

Configuration of the device

Directly from the topologic view of the user interface, a simple click drives the user to the configuration screen of the selected device.

Programming and debug

Programming is an essential step, and the user has to carefully design it to be as efficient as possible. Advanced control and HMI functions cover all the needs of an engineer in terms of creating the control and visualisation system. Powerful tools allow debug and functional tests such as simulation, step by step execution, break points and trace.

Commissioning

For an easy and fast diagnostic, the menu commissioning allows the user to check the online state of his architecture. Through the topologic view of the configuration, the devices display if you are logged in or not, as well as if they are in run or stop mode.

Documentation

Because a printed file of the project is an important element, it is possible to build and customize the project report:

- select the items to be included in the report,
- organize the sections,
- define the page layout
- and then launch the printing.

Transparency

SoMachine supports Device Type manager (DTM) because it is a field device tool (FDT) container.

With DTM's representing field device in SoMachine, direct communications are possible to every single device via SoMachine, the controller and the field bus (Modbus for all devices and CANopen for the I/O's).

From the SoMachine unique environment, the remote devices can be set-up off-line and tuned on-line.

Dedicated application libraries (AFB libraries)

SoMachine can be extended through its solution extension DVD. It integrates tested, validated, documented and supported expert application libraries dedicated to many Machine Builder applications. Their simple configuration speeds up design, commissioning, installation and troubleshooting.

These libraries cover the following applications:

- Packaging,
- Hoisting,
- Conveying
- Pumping

Tested Validated Documented Architectures (TVDA)

SoMachine provides a variety of preset projects with ready-to-use architectures you can adapt to individual requirements. Some of them are generic TVDA, they are based on controllers configuration. The solution extension DVD brings specific application solutions oriented TVDA's to SoMachine.

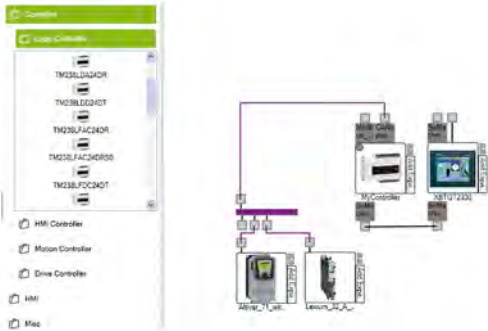

Configuration

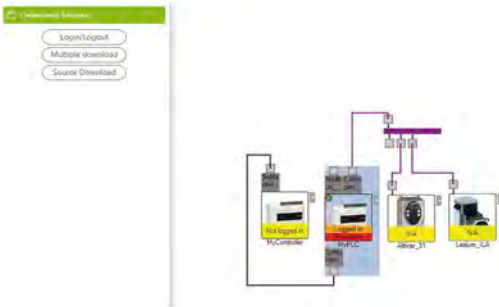

Commissioning

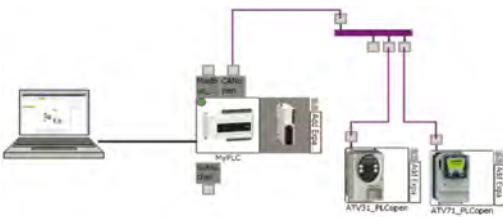

Transparency



Application Function Blocks

SoMachine characteristics	
Overview	
IEC 61131-3 programming languages	<ul style="list-style-type: none"> ■ IL (Instruction List) ■ LD (Ladder Diagram) ■ SFC (Sequential Function Chart) ■ ST (Structured Text) ■ FBD (Function Block Diagram) ■ + CFC (Continuous Function Chart)
Controller programming services	<ul style="list-style-type: none"> ■ Multi-tasking: Mast, Fast, Event ■ Functions (Func) and Function Blocks (FBs) ■ Data Unit Type (DUTs) ■ On-line changes ■ Watch windows ■ Graphical monitoring of variables (trace) ■ Breakpoints, step-by-step execution ■ Simulation ■ Visualization for application and machine set-up
HMI-based services	<ul style="list-style-type: none"> ■ Graphics libraries containing more than 4000 2D and 3D objects. ■ Simple drawing objects (points, line, rectangles, ellipses, etc ...) ■ Preconfigured objects (button, switch, bar graph, etc ...) ■ Recipes (32 groups of 256 recipes with max. 1024 ingredients) ■ Action tables ■ Alarms ■ Printing ■ Java scripts ■ Multimedia file support: wav, png, jpg, emf, bmp ■ Variable trending
Motion services	<ul style="list-style-type: none"> ■ Embedded devices configuration and commissioning ■ CAM profile editor ■ Sample application trace ■ Motion and drive function blocks libraries for inverters, servos and steppers ■ Visualization screens ■ Logical encoder
Global services	<ul style="list-style-type: none"> ■ User access and profile ■ Project documentation printing ■ Project comparison (control) ■ Variable sharing based on publish/subscribe mechanism ■ Library version management ■ Energy efficiency machine monitoring
Integrated fieldbus configurators	<ul style="list-style-type: none"> ■ Control network: <ul style="list-style-type: none"> □ Modbus Serial Line □ Modbus TCP ■ Field bus: <ul style="list-style-type: none"> □ CANopen □ CANmotion ■ Connectivity: <ul style="list-style-type: none"> □ Profibus-DP □ Ethernet IP
Expert and solutions libraries	<ul style="list-style-type: none"> ■ PLCopen function blocks for Motion control <ul style="list-style-type: none"> □ Example: MC_MoveAbsolute, MC_CamIn, ServoDrive, ... ■ Packaging function blocks <ul style="list-style-type: none"> □ Example: Analog film tension control, rotary knife, lateral film position control, ... ■ Conveying function blocks <ul style="list-style-type: none"> □ Example: tracking, turntable, conveyor , ... ■ Hoisting functions <ul style="list-style-type: none"> □ Hoisting function blocks: anti-sway, anti-crab, hoisting position synchronisation, ... □ Application template for industrial crane ■ Pumping application <ul style="list-style-type: none"> □ Pumping function blocks □ Application template for booster ■ Energy Efficiency library

SoMachine software suite

Simplify machine programming and commissioning

Product offer

SoMachine software is delivered on a DVD, it is a product oriented version that includes all SoMachine features related to generic hardware (M238, M258, LMC058, XBT GC, Altivar IMC), as well as generic TVDA.

The solution features are added to SoMachine by installing its solution extension DVD. It includes all SoMachine solutions hardware, plus all the dedicated application libraries and TVDA.

References

- SoMachine is available in 6 languages:
 - English
 - French
 - German
 - Italian
 - Spanish
 - Simplified Chinese.
- System Requirements:
 - Processor: Pentium 4 - 1,8 GHz or higher , Pentium M 1.0 GHz or equivalent
 - RAM Memory: 2 GByte; recommended: 3 GByte
 - Hard Disk: 3.5 GB, recommended: 5 GB
 - OS: Windows XP Professional, Windows 7 Professional 32/64 bytes
 - Drive: DVD reader
 - Display: 1024 × 768 pixel resolution or higher
 - Peripherals: a Mouse or compatible pointing device
 - Peripherals: USB interface
 - Web Access: Web registration requires Internet access
- The documentation is supplied in electronic format: complete on-line help plus complementary documentation in pdf version.

SoMachine solution extension for Solution controllers (1)

Added controllers	Added TVDA	Added libraries	Reference (2) DVDs and Licence / number & type
■ M238S	- Optimized CANopen Altivar IMC	Hoisting	MSDCHLLMUV31S0 / 1 (Single)
■ M258S		Conveying	MSDCHLLMTV31S0 / 10 (Team)
■ LMC058S	- Performance CANmotion	Packaging	
■ XBT GC with CANopen module type S	LMC058	Pumping	MSDCHLLMFV31S0 /100 (Facility)
■ XBT GT/GK with control function type S	- Hoisting Optimized		
■ Altivar IMC with control function type S	CANopen M238		
	- Conveying Performance		
	CANmotion LMC058		

SoMachine software compatibility and hardware control platforms

Product type	Version
Logic controller Modicon M238	≥ V1.0
HMI controller XBT GC	
Logic controller Modicon M238S	≥ V2.0
Logic controller Modicon M258	
Logic controller Modicon M258S	
Motion controller Modicon LMC058	≥ V3.0
Motion controller Modicon LMC058S	≥ V2.0
HMI controller XBT GT/GK with control function type S, XBT GC with CANopen module type S	
Altivar IMC integrated controller card	≥ V3.1
Altivar IMC integrated controller card with control function type S	≥ V2.0
TM5 CANopen Interface	≥ V3.0
TM7 CANopen Interface block	
Altivar IMC integrated controller card (with patch)	

(1) For this offer, please contact your Customer Care Centre.

(2) Each reference for SoMachine solution software contains: one generic trail DVD, one solution extension V3.1 DVD and one licence.

chapter 3

Hardware control platforms



All technical information about products listed in this chapter
are available on www.schneider-electric.com

- **Drive controller for Solutions with AFB, HMI controllers, Logic controllers compact base for Solutions with AFB**
 - General selection guide 3/2
- **Drive controller for Solutions with AFB**
 - **Altivar IMC drive controller card type S solutions with AFB for Altivar 61 variable speed drive**
 - Presentation 3/4
 - Functions 3/6
 - Description, References 3/7
- **HMI controllers**
 - **Magelis™ XBT GC HMI Controllers**
 - Selection guide 3/8
 - Presentation 3/10
 - Functions 3/12
 - Description 3/13
 - References 3/14
 - Combination 3/15
- **Logic compact bases for Solutions with AFB**
 - **Modicon M238 logic controller compact base for Solutions with AFB**
 - Selection guide 3/16
 - Presentation 3/18
 - Description 3/20
 - References 3/21
 - Memory structure 3/23
 - **Modicon M258 logic controller compact base for Solutions with AFB**
 - Selection guide 3/24
 - Presentation 3/26
 - Description 3/31
 - References 3/32
- **I/O expansion modules for Hardware platform control**
 - **Local and remote I/O expansion modules**
 - Selection guide 3/34
 - **Distributed I/O expansion modules**
 - Selection guide 3/34



Hardware control platforms

Drive controller type S Solutions with AFB,
HMI controllers,
Logic controllers for Solutions with AFB

3

<p>Applications</p>	<p>Control by integration of automation functions on Altivar 61 variable speed drive</p>	<p>Data control and parameter-setting IEC 1131-2 control function Display of text messages, graphic objects and mimics</p>
<p>Machines</p>	<p>Textile, hoisting, pumping, woodworking, etc.</p>	<p>All machine types, pumping</p>
		
<p>Configuration software</p>	<p>SoMachine</p>	
<p>Power supply</p>	<p>24 V ---</p>	<p>24 V ---</p>
<p>Embedded inputs <i>(depending on model)</i></p>	<ul style="list-style-type: none"> <input type="checkbox"/> 10 digital inputs including 4 available for 2 HSC inputs or 2 incremental encoders <input type="checkbox"/> 2 analog inputs 	<p>12 to 16 digital outputs</p>
<p>Embedded outputs <i>(depending on model)</i></p>	<ul style="list-style-type: none"> <input type="checkbox"/> 6 transistor outputs <input type="checkbox"/> 2 analog outputs 	<ul style="list-style-type: none"> <input type="checkbox"/> 6 to 16 transistor outputs
<p>I/O expansion</p>	<p>With expansion card VW3A320●:</p> <ul style="list-style-type: none"> <input type="checkbox"/> Digital, analog, relay, frequency control and probe I/O (see page 3/4) 	<p>With Modicon TM2 expansion modules:</p> <ul style="list-style-type: none"> <input type="checkbox"/> Digital I/O (see page 3/34) <input type="checkbox"/> Analog I/O (see page 3/34)
<p>Integrated functions</p>	<ul style="list-style-type: none"> <input type="checkbox"/> HSC <input type="checkbox"/> Analog <input type="checkbox"/> Position control 	<ul style="list-style-type: none"> <input type="checkbox"/> Display of animated mimics and current date and time <input type="checkbox"/> Control and modification of numeric or alphanumeric variables <input type="checkbox"/> Real-time and trending curves with log <input type="checkbox"/> Multiwindow management <input type="checkbox"/> Page calls initiated by the operator <input type="checkbox"/> Multilingual application management <input type="checkbox"/> Recipe management <input type="checkbox"/> Data processing via Java script <input type="checkbox"/> Application support and external memory logs <input type="checkbox"/> Management of printers and barcode readers <input type="checkbox"/> Execution of programmed logic sequences <input type="checkbox"/> CANopen fieldbus device management <input type="checkbox"/> Management of digital/analog I/O on expansion modules
<p>Communication</p> <p style="text-align: right;">Embedded</p> <hr/> <p style="text-align: right;">Option</p>	<ul style="list-style-type: none"> <input type="checkbox"/> Protocols: Ethernet Modbus TCP, UDP, TCP, SNMP <input type="checkbox"/> Web/FTP servers <input type="checkbox"/> CANopen master <input type="checkbox"/> Ethernet <input type="checkbox"/> ModbusPlus <input type="checkbox"/> Uni-Telway <input type="checkbox"/> InterBus-S <input type="checkbox"/> Profibus DP <input type="checkbox"/> DeviceNet <input type="checkbox"/> Ethernet Modbus/TCP <input type="checkbox"/> Fipio <input type="checkbox"/> EtherNet IP <input type="checkbox"/> CC-Link <input type="checkbox"/> Lonworks <input type="checkbox"/> METASYS N2 <input type="checkbox"/> APOGEE FLN <input type="checkbox"/> BACnet 	<ul style="list-style-type: none"> <input type="checkbox"/> Serial links: RS 232C/RS 422/485 <input type="checkbox"/> Protocols: Uni-TE, Modbus, Modbus TCP/IP <input type="checkbox"/> Ethernet <input type="checkbox"/> Parallel printer <input type="checkbox"/> CANopen master
<p>User memory</p> <p style="text-align: right;">RAM</p> <hr/> <p style="text-align: right;">Flash</p>	<p>2 MB</p> <hr/> <p>2 MB</p>	<p>512 KB (SRAM)</p> <hr/> <p>16 to 32 MB (Flash EEPROM)</p>
<p>Controller</p>	<p>ATV IMC drive controller card type S solutions with AFB Control by integration of automation functions on Altivar 61 variable speed drives</p>	<p>XBTGC controllers</p>
<p>Pages</p>	<p>3/4</p>	<p>3/8</p>

High speed counter control and simple position control	Speed control, high speed counter control and motion control
Packaging, conveying, hoisting, pumping, ...	Packaging, conveying, hoisting, pumping, ...



24 V $\overline{\text{DC}}$ and 100/240 V \sim	24 V $\overline{\text{DC}}$
<ul style="list-style-type: none"> <input type="checkbox"/> 14 digital inputs, 8 of which can be configured as fast inputs <input type="checkbox"/> 4 transistor outputs + 6 relay outputs or 10 transistor outputs, 4 of which can be configured as fast outputs 	<ul style="list-style-type: none"> <input type="checkbox"/> 26 to 38 digital inputs including 8 counter inputs (200 kHz) <input type="checkbox"/> 4 analog inputs <input type="checkbox"/> 16 to 28 transistor outputs including 4 reflex outputs <input type="checkbox"/> Up to 12 relay outputs
<p>With Modicon TM2 modules:</p> <ul style="list-style-type: none"> <input type="checkbox"/> Digital I/O (see page 3/34) <input type="checkbox"/> Analog I/O (see page 3/34) 	<p>With Modicon TM5 compact blocks:</p> <ul style="list-style-type: none"> <input type="checkbox"/> Digital and analog I/O (see page 3/34) <p>With Modicon TM5 modules:</p> <ul style="list-style-type: none"> <input type="checkbox"/> Digital (see page 3/34) <input type="checkbox"/> Digital/Analog (see page 3/34) <input type="checkbox"/> Analog (see page 3/34)
<ul style="list-style-type: none"> <input type="checkbox"/> HSC <input type="checkbox"/> PTO <input type="checkbox"/> PWM <input type="checkbox"/> PID control <input type="checkbox"/> Event processing 	<ul style="list-style-type: none"> <input type="checkbox"/> HSC <input type="checkbox"/> Analog <input type="checkbox"/> Position control <input type="checkbox"/> PWM
<ul style="list-style-type: none"> <input type="checkbox"/> Master/slave type isolated serial link <input type="checkbox"/> Protocols: Modbus master/slave RTU/ASCII, ASCII <input type="checkbox"/> CANopen master 	<ul style="list-style-type: none"> <input type="checkbox"/> Serial links: RS232/RS485 <input type="checkbox"/> Web/FTP servers <input type="checkbox"/> Protocols: , Modbus master/slave RTU/ASCII, ASCII <input type="checkbox"/> CANopen master <input type="checkbox"/> Ethernet
<ul style="list-style-type: none"> <input type="checkbox"/> Ethernet <input type="checkbox"/> Profibus <input type="checkbox"/> DeviceNet 	<ul style="list-style-type: none"> <input type="checkbox"/> Modbus RS232 serial link <input type="checkbox"/> Modbus RS485 serial link <input type="checkbox"/> Profibus DP (slave)
500 or 1000 KB (depending on model)	64 MB (program + data)
2 MB	128 MB

M238 logic controller type S, compact base for solutions with AFB	M258 logic controller type S, compact base for solutions with AFB
--	--

3/16	3/24
------	------

Hardware control platforms

Drive controller

Altivar IMC drive controller card type S solutions with AFB, for Altivar 61 variable speed drive



Altivar IMC integrated controller card

3

Presentation

The Altivar IMC drive controller card type S Solutions with AFB forms a part of Flexible Machine Control approach, a key component of MachineStruxure™, which brings you maximum flexibility and ensures the most optimised control solution. The Altivar IMC drive controller card type S Solutions with AFB **VW3 A3521S0** is a compact optimised solution developed for Altivar 71 variable speed drives. When equipped with the ATV IMC card type S Solutions with AFB, Altivar 61 drives become controllers capable of meeting the needs of machine manufacturers in applications such as textiles, **hoisting**, pumping or woodworking, etc.

The Altivar IMC drive controller card type S Solutions with AFB **VW3 A3521S0** is configured and programmed using SoMachine software (see page 2/2).

The Altivar IMC card type S Solutions with AFB boosts the expansion capability of machines and allows us to meet the Machine Builder market's requirements in terms of performance, simplicity of use and openness.

Installation

The Altivar IMC card type S Solutions with AFB is designed for integration on Altivar 61 variable speed drives in conjunction with other Altivar 61-specific cards, such as I/O expansion cards and communication cards.

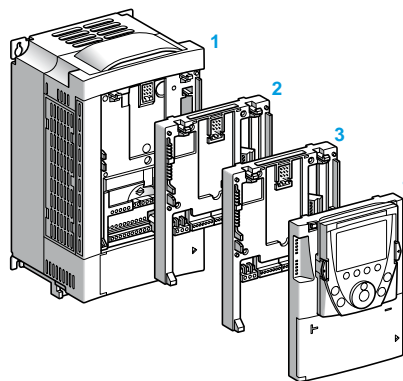

- 1 Altivar 61 drive and graphic display terminal
- 2 Altivar IMC card **VW3 A3521S0**
- 3 I/O expansion card **VW3A32●●** or communication card **VW3A33●●**

Note: Only one I/O expansion card or communication card can be mounted simultaneously with the Altivar IMC card type S Solutions with AFB on an Altivar 61 drive.

Special features

User memory	RAM	2 MB
	Flash	2 MB
Data storage memory FRAM (Ferroelectric RAM)		64 KB
Typical time (for 1000 Boolean instructions)		942 μs
User program size		1 MB
Power supply		24 V ~
Inputs	Digital	10 x 24 V ~ inputs, 4 of which can be used for 2 high-speed counter inputs (100 kHz) or 2 incremental encoders (A/B) (100 kHz)
	Analog	2 x 0...20 mA inputs
Outputs	Digital	6 transistor outputs (2 A) - source
	Analog	2 x 0...20 mA outputs
Built-in communication ports	RJ45 port	Ethernet Modbus TCP, Web/FTP Server
	SUB-D connector (male 9-way)	Master CANopen bus (16 slaves)
	USB Mini-B port	SoMachine software programming
Real-time clock		Integrated

Hardware control platforms

Drive controller

Altivar IMC drive controller card type S solutions with AFB, for Altivar 61 variable speed drive

Performance

Reduce the time it takes to develop your machines

■ The use of a single SoMachine programming software environment offers a number of advantages:

- A single project file
- A single software program
- A single download for the whole application

■ The ease of use of PLCopen function blocks significantly reduces the time needed to program motion control and independent axis control on machines.

A more powerful machine

The Altivar IMC drive controller card type S Solutions with AFB has 8 tasks to suit different machine requirements (cyclic, event-triggered, free).

A task can be synchronized with the task of the drive in which it is embedded. This task manages the speed reference, the torque reference, the speed feedback, the torque feedback, the number of encoder pulses feedback in order to increase machine performance.

A more intelligent drive

- Performs more complex operations (2 MB memory)
- Reduces program loading time (Mini-B USB connectors)
- Communication with all the other system devices (built-in Ethernet and CANopen connection ports)

Transparency of your machines

Access to all the other devices in the system architecture via CANopen is totally transparent due to FDT/DTM technology.

Development and technology

The Altivar IMC drive controller card type S Solutions with AFB has been developed with two criteria in mind: low cost and practicality.

■ Low cost because the standard equipment for the Altivar IMC card type S Solutions with AFB comprises:

- Sixteen discrete I/O
- A built-in Ethernet port
- Two analog inputs
- Two analog outputs
- And a CANopen master

■ Practicality because the Altivar IMC card type S Solutions with AFB is ideal for integration in Altivar 61 drives, and can therefore use:

- Their inputs/outputs
- Their communication cards
- Their parameters: speed, current, torque, etc.
- Their remote graphic display terminal
- And also the inputs/outputs in their I/O expansion cards
- Plus the speed feedback counter in the encoder interface cards

Software configuration

Configuration and programming of the Altivar IMC drive controller card type S Solutions with AFB and equipment in Schneider Electric's "Flexible Machine Control" concept are both designed to cut costs and optimize your machine performance.

Schneider Electric's **SoMachine** software platform can be used to program Altivar IMC drive controller card type S Solutions with AFB using:

■ IEC 61131-3 programming languages: Instruction List (IL), Ladder Diagram (LD), Function Block Diagram (FBD), Sequential Function Chart/Grafset (SFC) and Structured Text (ST)

■ CFC (Continuous Function Chart) language.

PLCopen function blocks are used for managing motion control and axis control on your machines.

See page 2/2.

Integration in the Schneider Electric product offer

Combined with other dedicated products in the Schneider Electric offer, such as Altivar variable speed drives, Lexium servo drives, Magelis HMI terminals, TeSys motor starters and contactors, the Altivar IMC drive controller card type S Solutions with AFB can be integrated transparently in a number of architectures.



SoMachine software platform

Hardware control platforms

Drive controller

Altivar IMC drive controller card type S solutions with AFB, for Altivar 61 variable speed drive

3

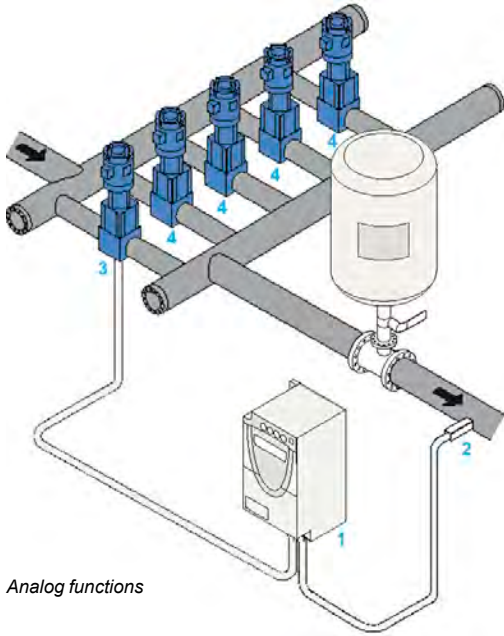

Analog functions

Functions

Analog functions

For machines that require functions to process data issued by analog sensors/ actuators (voltage or current), temperature sensors, pressure or PID control sensors, the Altivar IMC drive controller card type S Solutions with AFB has, as standard, 2 analog inputs (voltage or current) with 10-bit resolution and 2 analog outputs (current) with 10-bit resolution.

- 1 Altivar IMC drive controller card type S Solutions with AFB installed on Altivar 61
- 2 Pressure sensor
- 3 Variable speed pump
- 4 Fixed speed pumps

Communication function

Ethernet

The Altivar IMC drive controller card type S Solutions with AFB has a built-in RJ45 Ethernet port (10/100 Mbps, MDI/MDIX) with Ethernet TCP Modbus, SoMachine on Ethernet, UDP, TCP and SNMP protocols.

In addition, the Altivar IMC card type S Solutions with AFB has an embedded Web Server and FTP Server.

As well as the default address based on the MAC address, it is possible to assign a controller IP address via a DHCP server or via a BOOTP server.

Customization function on the graphic display terminal

Menu 1.14

The remote graphic display terminal on Altivar 61 drive includes a menu dedicated to the Altivar IMC drive controller card type S Solutions with AFB.

The user is offered a graphic display of 8 lines of 24 characters.

This menu can be customized simply and directly using the SoMachine software.

The user can define the language, name, unit, decimal point, and the type of parameter he wishes to customize for his own application. The user can also define alarms and error messages for his application.

Clock function

A time and date-stamping function combined with a clock backed up by a lithium battery makes it possible to keep a log of events that have occurred. When the Altivar IMC drive controller card type S Solutions with AFB is installed in the drive, drive faults are automatically time and date-stamped without the need for any special programming.

Communication

The Altivar IMC drive controller card type S Solutions with AFB has the following built-in communication ports:

Communication ports	Use
1 x RJ45 (MDI/MDIX port)	<input type="checkbox"/> FTP server <input type="checkbox"/> Web server <input type="checkbox"/> Modbus TCP server <input type="checkbox"/> Modbus TCP client <input type="checkbox"/> Manager SoMachine <input type="checkbox"/> SNMP <input type="checkbox"/> Modbus device
1 x mini-USB	Programming port (480 Mbps)
1 x 9-way male SUB-D	Master CANopen connection

Embedded Ethernet

The Altivar IMC drive controller card type S Solutions with AFB has an embedded Ethernet link via a direct connection to its RJ45 port.

- Speed: "10 BaseT" and "100 BaseTX" with auto-negotiation
- RJ45 port (MDI/MDIX): automatic adaptation to a straight or crossed cable

Protocols	Number of connections
Modbus server	8
Modbus device	2
FTP server	4
Web server	10



Menu 1.14

Hardware control platforms

Drive controller

Altivar IMC integrated controller card for Altivar 61 variable speed drive

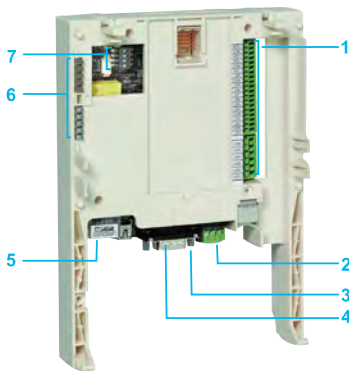

Description

The Altivar IMC drive controller card type S Solutions with AFB comprises:

- 1 Three spring connectors for:
 - 10 digital inputs
 - 6 digital outputs
 - 2 analog inputs
 - 2 analog outputs
 - 2 commons
- 2 A connector with removable screw terminals, 3 contacts at intervals of 3.81 for the 24 V $\bar{\text{m}}$ power supply
- 3 A mini USB-B connector for programming using SoMachine software
- 4 A 9-way SUB-D connector for connection to the CANopen machine bus
- 5 An RJ45 connector for connection of the SoMachine software workshop and/or connection to an Ethernet Modbus TCP network
- 6 Five LEDs:
 - 1 green/yellow ETH LED for Ethernet activity
 - 1 green/red NS (Network status) LED
 - 1 green/red MS (Module status) LED
 - 1 green/red CAN (CANopen activity) LED
 - 1 green/red LED programmable by the user
- 7 Four configuration selector switches

References

Variable speed drives

Designation	Reference
Altivar 61 variable speed drives	Refer to the "Altivar 61 variable speed drives" catalogue or visit our website www.schneider-electric.com

Altivar IMC drive controller card type S Solutions with AFB for Altivar 61

Designation	Voltage	Reference	Weight kg lb
Altivar IMC drive controller card type S Solutions with AFB	24 V $\bar{\text{m}}$	VW3A3521S0	0.185 kg 0.408 lb

I/O expansion cards for Altivar 61(1)

Designation	Type of I/O						Reference	Weight kg lb
	Logic input	Logic output	Analog input	Analog output	PTC probe input (2)	Frequency control input		
I/O expansion cards (2)	4	3	–	–	1	–	VW3A3201	0.300 0.661
	4	3	2	2	1	1	VW3A3202	0.300 0.661

For more information about digital I/O cards, visit our website www.schneider-electric.com.

Communication cards

Designation	Protocols available (depending on model)	Reference	
VW3A3 3●● communication cards	<ul style="list-style-type: none"> <input type="checkbox"/> Modbus Plus <input type="checkbox"/> Uni-Telway <input type="checkbox"/> InterBus-S <input type="checkbox"/> Profibus DP <input type="checkbox"/> DeviceNet <input type="checkbox"/> Ethernet Modbus TCP <input type="checkbox"/> Fipio 	<ul style="list-style-type: none"> <input type="checkbox"/> EtherNet IP <input type="checkbox"/> CC-Link <input type="checkbox"/> Lonworks <input type="checkbox"/> METASYS N2 <input type="checkbox"/> APOGEE FLN <input type="checkbox"/> BACnet 	Refer to "Altivar 61 variable speed drives" catalogue, or visit our website www.schneider-electric.com

Connection cable

Designation	Use	Length	Reference	Weight kg lb
Programming cable	From the mini USB-B port on the Altivar IMC drive controller card type S to the type A USB port on the PC terminal for programming and updating firmware	3 m 9.843 ft	TCSXCNAMUM3P	0.065 0.143

(1) Altivar 61 variable speed drive can only take one I/O expansion card with the same reference.
 (2) This PTC probe input must never be used to protect an ATEX motor in applications in explosive atmospheres. Please refer to the ATEX guide which is available on our website "www.schneider-electric.com".



Altivar 61 variable speed drives



VW3A3521S0



VW3A3 202

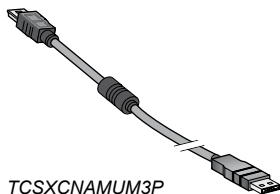

TCSXCNAMUM3P

3

Applications

Display of text messages, graphic objects and mimics
Control and configuration of data
IEC 1131-2 control function

Terminal type

HMI Controllers



Display

Type	
Capacity	

Back-lit monochrome (amber or red mode) STN LCD
(320 x 240 pixels)
3.8" (monochrome)

Data entry

Static function keys	
Dynamic function keys	
Service keys	
Alphanumeric keys	

Via touch screen
–
–
–
–

Memory capacity

Application	
Extension	

16 MB EPROM Flash
–

Functions

Maximum number of pages and maximum number of instructions	
Variables per page	
Programmed logic	
Counting/positioning	
Control (PID)	
Representation of variables	
Recipes	
Curves	
Alarm logs	
Real-time clock	

Limited by internal Flash EPROM memory capacity

Unlimited (8000 variables max.)
5 languages according to IEC 1131-2 (LD, ST, FBD, SFC, IL)
4 x 100 kHz fast counter inputs/4 x 65 kHz pulse train outputs
Yes
Alphanumeric, bitmap, bargraph, gauge, tank, tank level indicator, curves, polygon, button, indicator

32 groups of 64 recipes comprising 1024 ingredients max.
Yes, with log
Yes
Built-in

I/O

Integrated	
I/O modular extensions	

12 x 24 V ∓ digital inputs
6 sink or source transistor outputs (1)

Two M238 I/O modules max.

Communication

Downloadable protocols	
Asynchronous serial link	
USB ports	
Buses and networks	
Printer link	

–
–
1
1 CANopen master with optional module (XBTZGC CAN)
–
USB port for parallel printer

Design software

SoMachine with Windows XP Professional and Windows 7 Professional 32/64-bit, see page 2/5

Operating system

Magelis
(131 MHz RISC CPU)

Terminal type

XBTGC1100 T/U

Pages

3/14

(1) Depending on model



Backlit monochrome STN LCD (320 x 240 pixels)	Colour STN LCD (320 x 240 pixels)
5.7" (monochrome)	5.7" (colour)

16 x 24 V \pm digital inputs
 16 sink or source transistor outputs (1)
 Three M238 I/O modules max.

Uni-TE, Modbus, Modbus TCP/IP (1) and for PLC brands: Mitsubishi, Omron, Allen-Bradley and Siemens
 RS 232C/RS 422/485 (COM1)

Ethernet TCP/IP (10BASE-T/100 BASE-TX)

XBTGC2120 T/U	XBTGC2230 T/U
----------------------	----------------------

3/14	3/14
------	------



Magelis XBTGC HMI Controllers

3

Presentation

Magelis HMI Controllers are part of Schneider's Flexible Machine Control concept, a key element in MachineStruxure™.

The Magelis HMI Controller offer brings together Human Machine Interface and control functions within in a single product. This reduces the amount of equipment required and the associated costs throughout the life cycle of the machine.

Magelis XBTGC HMI Controllers

The compact design of Magelis XBTGC HMI Controllers optimizes setup.

This range comprises six touch screen terminals, with the following, depending on the model:

- 3.8" monochrome screen, 12 integrated inputs/6 integrated outputs (sink or source)
- 5.7" monochrome or colour screen, 16 integrated inputs/16 integrated outputs (sink or source)
- A wide choice of communication interfaces (USB, serial link, CANopen and Ethernet)

In order to adapt easily to different configurations, it is possible to add digital or analog I/O expansion modules at the rear of the Controller.

Operation

With their fast, multitasking processors, the HMI Controllers combine HMI and control functions and share the same screen and communication features and dimensions.

The internal memory can be freely used by both the HMI function and the control function.

Processing is split 75% on the HMI part and 25% on the control part. The processing can be configured for 3 tasks, including 1 master task.

XBTGC HMI Controllers also share the same I/O modules, the same Telefast pre-wired system and the same peripherals on the CANopen bus as the M238 logic controller.



SoMachine



Vijeo Designer
(included in SoMachine)

Configuration

Magelis XBT GC HMI Controllers are configured using Schneider Electric's unique machine automation software, SoMachine.

This software, combining both HMI and control functions, is based on Vijeo Designer software in the Windows XP Professional and Windows 7 Professional 32/64-bit environment.

SoMachine software boasts an advanced user interface with many configurable windows, enabling unique projects to be developed quickly and easily. See page 2/5.

Communication

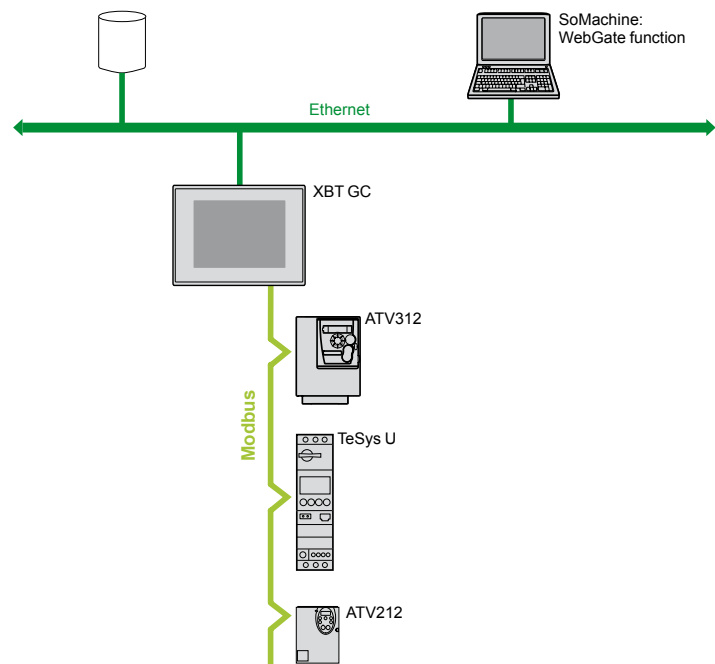

Examples of communication architectures

Depending on the model:

- Magelis HMI Controllers communicate with automation devices via 1 or 2 integrated serial links using the following communication protocol: Schneider Electric (Uni-TE, Modbus)
- Magelis HMI Controllers can be connected to Ethernet TCP/IP networks with the Modbus TCP protocol or a third-party protocol. They also can be used as the CANopen master to control the peripherals which can be connected on this bus.

Hardware control platforms

HMI Controllers

Magelis™ XBTGC HMI Controllers

3

Functions

Magelis HMI Controllers are part of Schneider's Flexible Machine Control concept, a key element in MachineStruxure™.

Magelis XBTGC HMI Controllers offer the following HMI functions:

- Display of animated mimics with 8 types of animation (pressing the touch panel, colour changes, filling, movement, rotation, size, visibility and value display)
- Control, modification of numeric and alphanumeric values
- Display of current date and time
- Real-time curves and trend curves with log
- Alarm display, alarm log and management of alarm groups
- Multi-window management
- Page calls initiated by the operator
- Multilingual application management (10 languages simultaneously)
- Recipe management
- Data processing via Java script
- Application support and USB key external memory logs
- Management of serial printers and barcode readers

Magelis XBTGC HMI Controllers (1) have been designed for Transparent Ready architectures and equipment (combination of Web and Ethernet TCP/IP technologies). With the WebGate function, it is possible to control or carry out maintenance remotely.

Magelis XBTGC HMI Controllers offer the following functions for control:

- Execution of programmed logic sequences with the five IEC 1131-2 languages (LD, ST, FBD, SFC, IL)
 - Management of equipment on the CANopen fieldbus
- In addition to these functions, Magelis XBT GC HMI Controllers manage:
- Integrated and remote I/O on expansion modules
 - Remote analog I/O on expansion modules

Operating modes for the terminals

The illustrations below show which equipment can be connected to XBT terminals based on their two operating modes.

Edit mode

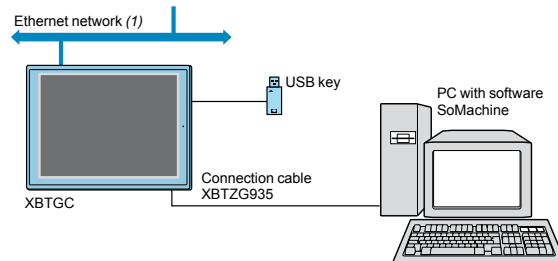

Run mode

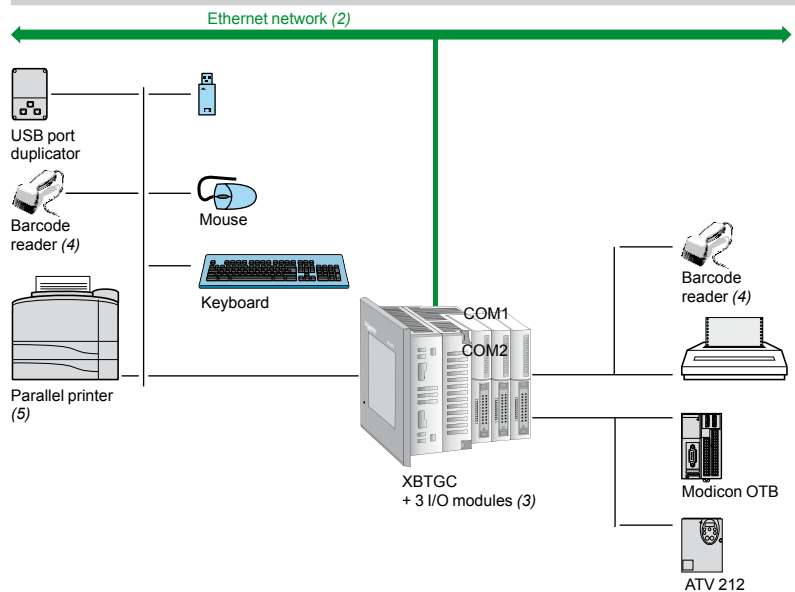

(1) Depending on model

(2) With XBTGC 2230T/U

(3) With XBTGC●●●●T/U, maximum 2/3 I/O modules according to model

(4) Should be a DataLogic Gryphon barcode reader

(5) Should be a Hewlett Packard printer via a USB/PIO converter

Hardware control platforms

HMI Controllers

Magelis™ XBTGC HMI Controllers with 3.8" screen,

Magelis™ XBTGC HMI Controllers with 5.7" screen

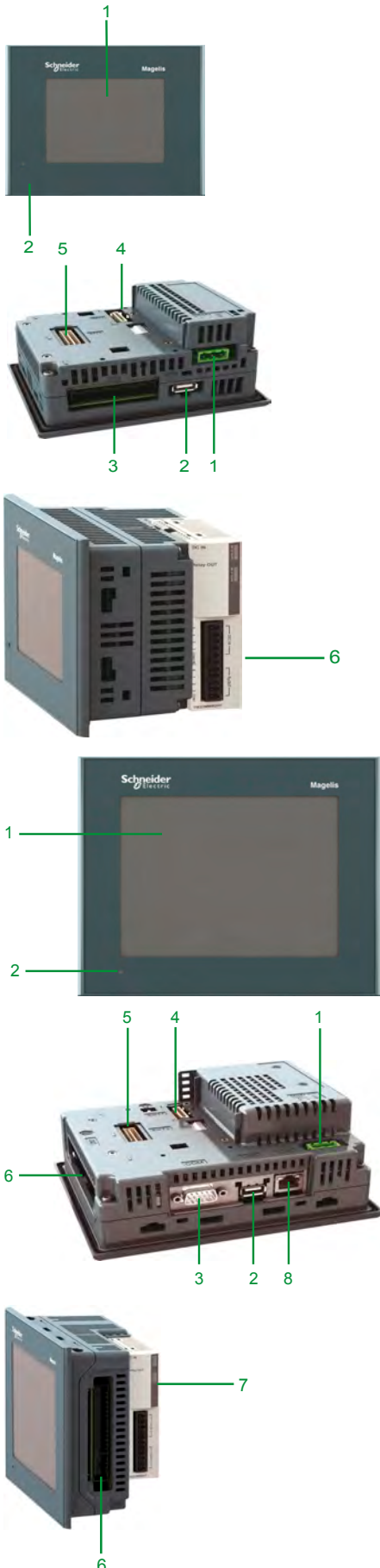

Description

Magelis XBTGC1100T and XBTGC1100U HMI Controllers

The front panel comprises:

- 1 A touch screen for displaying mimics (3.8" amber or red mode monochrome)
- 2 A control indicator showing the terminal's operating mode

The rear panel comprises:

- 1 A removable screw terminal block for 24 V $\overline{\text{---}}$ power supply
- 2 A type A USB master connector for peripheral connection and application transfer
- 3 A removable terminal block for 12 digital inputs and 6 digital outputs
- 4 An interface for connecting M238 logic controller I/O expansion modules
- 5 An interface for connecting the CANopen bus master module
- 6 Digital (TM2D●●) or analog (TM2A●●) I/O expansion module (to be ordered separately, see page 3/34)

It is possible to combine a maximum of two I/O expansion modules, depending on the module type (see page 3/34).

Magelis XBTGC2●20 and XBTGC2●30 HMI Controllers

The front panel comprises:

- 1 A touch screen for displaying mimics (5.7" monochrome or colour)
- 2 A multicolour indicator (green, orange and red) showing the terminal's operating mode

The rear panel comprises:

- 1 A removable screw terminal block for 24 V $\overline{\text{---}}$ power supply
- 2 A type A USB master connector for peripheral connection and application transfer
- 3 A 9-way male SUB-D connector for RS 232C or RS 422/485 serial link to PLCs (COM1)
- 4 An interface for connecting the M238 logic controller I/O expansion module
- 5 An interface for connecting the CANopen bus master module.
- 6 A removable terminal block for 16 digital inputs and 16 digital outputs
- 7 Digital (TM2D●●) or analog (TM2A●●) I/O expansion module (to be ordered separately, see page 3/34)

It is possible to combine a maximum of three I/O expansion modules, depending on the module type (see page 3/34).

For XBTGC2230 only:

- 8 An RJ45 connector for Ethernet TCP/IP 10BASE-T/100BASE-TX link

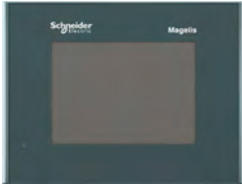

XBTGC1100●



XBTGC2●●●●



XBTZGUSB

Magelis XBTGC HMI Controllers (1)

Type of screen	No. of ports	Application memory capacity	Compact Flash memory	Integrated I/O	No. of Ethernet ports	Reference	Weight kg lb
3.8" screen							
STN amber or red	1 USB	16 MB	No	12 I/6 O source	-	XBTGC1100T	0.400 0.882
				12 I/6 O sink	-	XBTGC1100U	0.400 0.882
5.7" screen							
STN black and white mode	1 COM 1	16 MB	No	16 I/16 O source	-	XBTGC2120T	1.000 2.205
	1 USB			16 I/16 O sink	-	XBTGC2120U	1.000 2.205
5.7" screen							
STN colour	1 COM 1	16 MB	No	16 I/16 O source	1	XBTGC2230T	1.000 2.205
	1 USB			16 I/16 O sink	1	XBTGC2230U	1.000 2.205

Separate parts

Designation	Compatibility	Size	Reference	Weight kg lb
Protective sheets (5 peel-off sheets)	XBTGC 1100	-	XBTZG60	0.200 0.441
	XBTGC2●●0	-	XBTZG62	0.200 0.441

Designation	Description	Length	Reference	Weight kg
Remote USB port location for type A XBT terminal	Enables the USB port to be located remotely on the rear of the XBT terminal on a panel or cabinet door (Ø 21 mm / 826.772 in. mounting device)	1 m 3.281 ft	XBTZGUSB	-
Remote USB port location for mini type B XBT terminal		-	XBTZGUSBB	-
XBTGC connection to CANopen master fieldbus	Connection via card on bus extension	-	XBTZGCCAN	-
Cable for transferring application to PC	USB TTL connector	2 m 6.562 ft	XBTZG935	-

Replacement parts

Designation	Used for	Reference	Weight kg lb
Joints d'étanchéité	XBTGC1100	XBTZG51	0.030 0.066
	XBTGT21●0	XBTZG52	0.030 0.066
Attache USB	XBTGC 1100	XBTZGCLP2	-
	XBTGC 2●●0	XBTZGCLP4	-
Mounting kit	4 clips and screws (max. tightening torque: 0,5 Nm), included with XBTGC terminals	XBTZGFIX	0.100 0.220
Spring clip for expansion modules on XBTGC	XBTGC2●●0 terminals	XBTZGCHOK	0.030 0.066
Power supply connector	XBTGC1●●● / GC2●●●	XBTZGPWS1	0.030 0.066
Direct I/O connector	XBTGC1000	XBTZGDIO1	-
	XBTGC2000	XBTZGDIO2	-

(1) Terminals supplied with mounting kit (screw clips), locking device for USB connectors, spring clip for expansion modules (except XBTGC1100) and instruction sheet. The setup documentation for XBTGC terminals is supplied in electronic format with SoMachine software (see page 2/5).



XBTGC1●●● Combinations of two expansion modules

Combinations of 2 I/O expansion modules with XBTGC1●●●		Type (1)	Type (1)	Total thickness mm (in.)	
A	A	A	A	35.2 (1.280)	Permitted combinations
A	B	A	B	41.1 (1.618)	
B	B	B	B	47.0 (1.850)	
A	C	A	C	47.3 (1.862)	
B	C	B	C	53.2 (2.094)	
A	D	A	D	56.7 (2.232)	
C	C	C	C	59.4 (2.239)	Prohibited combinations
B	D	B	D	62.6 (2.465)	
C	D	C	D	68.8 (2.709)	
D	D	D	D	78.2 (3.079)	

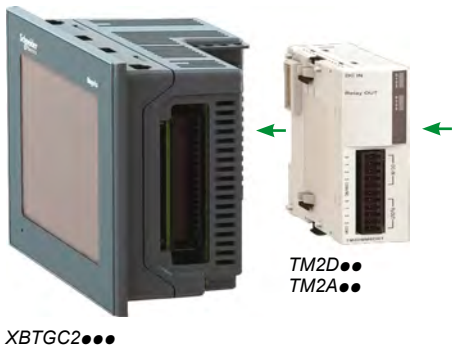

XBTGC2●●● Combinations of two expansion modules

Combinations of 2 I/O expansion modules with XBTGC2●●●		Type (1)	Type (1)	Total thickness mm (in.)	
A	A	A	A	35.2 (1.280)	Permitted combinations
A	B	A	B	41.1 (1.618)	
B	B	B	B	47.0 (1.850)	
A	C	A	C	47.3 (1.862)	
B	C	B	C	53.2 (2.094)	
A	D	A	D	56.7 (2.232)	
C	C	C	C	59.4 (2.239)	Prohibited combinations
B	D	B	D	62.6 (2.465)	
C	D	C	D	68.8 (2.709)	
D	D	D	D	78.2 (3.079)	

XBTGC2●●● Combinations of three expansion modules

Combinations of 3 I/O expansion modules with XBTGC2●●●		Type (1)	Type (1)	Type (1)	Total thickness mm (in.)	
A	A	A	A	A	52.8 (2.079)	Permitted combinations with hook (2)
A	A	A	B	B	58.7 (2.311)	
A	B	B	B	B	64.6 (2.543)	
B	B	B	B	B	70.5 (2.776)	
All other combinations					- (-)	Prohibited

(1) For digital (TM2D●●●) and analog (TM2A●●●) I/O expansion module types, see page 3/34:

- Type A: thickness 17.6 mm (0.693 in.)
- Type B: thickness 23.5 mm (1.169 in.)
- Type C: thickness 29.7 mm (0.693 in.)
- Type D: thickness 39.1 mm (1.539 in.)

(2) Hook included with product

Hardware control platforms

Modicon M238 logic controller, Compact base for Solutions with Application function Blocks (AFB)

3

Application

General control solutions for

- Hoisting
- Packaging
- Conveying
- Pumping
- ...



Voltage

24 V_{DC} (- 15% / + 20 %)

Certifications

CE, UL, CSA, ACA (C-Tick), GOST (pending)

Digital I/O

No. of 24 V _{DC} inputs	14, 8 of which can be configured as fast inputs
No. of outputs	10 transistor, 4 of which can be configured as fast outputs

14, 8 of which can be configured as fast inputs

10 transistor,
4 of which can be configured as fast outputs

I/O expansion

Max. number of modules	7: digital, analog, high-speed counter, (3 high-speed counter TM200HSC060●●)
Max. number of digital I/O	136/192/248 (1)

7: digital, analog, high-speed counter, (3 high-speed counter TM200HSC060●●)

136/192/248 (1)

Embedded function

HSC	8 x 100 kHz simple channels, 4 x 100 kHz simple channels and 1 x 100 kHz advanced channel (2) or 2 x 100 kHz advanced channels (2)
Motion or Reflex functions	4 channels, frequency: 100 Hz
PID regulation	Yes
Event processing	Yes, up to 4 event tasks can be activated by the fast inputs or by the integrated counter channels (on threshold)

8 x 100 kHz simple channels, 4 x 100 kHz simple channels and 1 x 100 kHz advanced channel (2) or 2 x 100 kHz advanced channels (2)

4 channels,
frequency: 100 Hz

Yes

Yes, up to 4 event tasks can be activated by the fast inputs or by the integrated counter channels (on threshold)

Connection via

4 removable screw terminal blocks (supplied as standard)
4 removable spring terminal blocks with optional unit TM238 RSSPT (ordered separately)

Embedded communication

RS 485/RS 232 serial port	Master/slave type isolated serial link RJ45 port, marking on front panel SL1 : 1 channel Protocols: <input type="checkbox"/> Default : Modbus slave, <input type="checkbox"/> Modbus master/slave RTU/ASCII, ASCII
RS 485 serial port	Master/slave type isolated serial link RJ45 port, marking on front panel SL2 : 1 channel Protocols: <input type="checkbox"/> Default : Modbus slave, <input type="checkbox"/> Modbus master/slave RTU/ASCII, ASCII
Terminal port "Prg. Port"	1 USB 2.0 (Mini B USB connector): Programming port for SoMachine software
CANopen	Conformity class M10, limited to 16 slaves for 1 master

Master/slave type isolated serial link

RJ45 port, marking on front panel SL1 :
1 channel
Protocols:
 Default : Modbus slave,
 Modbus master/slave RTU/ASCII, ASCII

Master/slave type isolated serial link

RJ45 port, marking on front panel SL2 :
1 channel
Protocols:
 Default : Modbus slave,
 Modbus master/slave RTU/ASCII, ASCII

1 USB 2.0 (Mini B USB connector): Programming port for SoMachine software

Conformity class M10, limited to 16 slaves for 1 master

User zone in internal RAM

Capacity	1000 KB
No. of instructions	25 K instructions depending on the language and type of instruction used

1000 KB

25 K instructions depending on the language and type of instruction used

Type of compact base

TM238 LFDC24DTS0

Page

3/21

(1) The 1st value corresponds to the maximum number of I/O (base and expansions) with expansion modules with screw terminals, the 2nd to expansion modules with spring terminals and the 3rd to expansion modules with HE 10 connectors.
(2) Advanced channel with two-phase signal inputs for encoder, threshold detection function and reflex function.



100-240 V ~ (+ 10% / - 15 %)

CE, UL, CSA, ACA (C-Tick), GOST (pending), CSA (Class 1, Division 2, Groups A, B, C, D)

14, 8 of which can be configured as fast inputs

4 transistor
+ 6 relay

7: digital, analog, high-speed counter, (3 high-speed counter TM200HSC060●●)

136/192/248 (1)

8 x 100 kHz simple channels, 4 x 100 kHz simple channels and 1 x 100 kHz advanced channel (2) or 2 x 100 kHz advanced channels (2)

4 channels,
frequency: 100 Hz

Yes

Yes, up to 4 event tasks that can be activated by the base's fast inputs or by the integrated counter channels (threshold attained)

4 removable screw terminal blocks (supplied as standard)
4 removable spring terminal blocks with optional unit TM238 RSSPT (ordered separately)

Master/slave type isolated serial link

RJ45 Port, marking on front panel SL1 : 1 channel

Protocols:

- Default : Modbus slave,
- Modbus master/slave RTU/ASCII, ASCII

Master/slave type isolated serial link

RJ45 port, marking on front panel SL2 : 1 channel

Protocols:

- Default : Modbus slave,
- Modbus master/slave RTU/ASCII, ASCII

1 USB 2.0 (Connecteur type USB mini-B): Programming port for SoMachine software

Conformity class M10, limited to 16 slaves for 1 master

1000 KB

25 K instructions depending on the language and type of instruction used

TM238 LFAC24DRS0

3/21

Hardware control platforms

Modicon M238 logic controller

Compact base for Solutions with Application function Blocks (AFB)

Presentation

The Modicon M238 logic controller is the compact base for solutions with AFB, high-performance and fully expandable PLC. It forms a part of Flexible Machine Control approach, a key component of MachineStruxure™, which brings you maximum flexibility and ensures the most optimised control solution.

Modicon M238 compact logic controllers offer an “all-in-one” solution in a compact unit (157 x 118 x 86 mm excluding expansion modules).

Two models are available, with different embedded communications and supply voltages.

■ Model **TM238LFDC24DTS0**, powered with 24 V $\bar{\text{DC}}$ offers:

- 14 x 24 V $\bar{\text{DC}}$ inputs, including 8 fast inputs, dedicated to special functions such as high-speed counting (HSC)
- 10 x 24 V $\bar{\text{DC}}$ solid state outputs, including 4 fast outputs, dedicated to special functions such as PWM and PTO.
- An RS 232/RS 485 serial link (SoMachine-Network, Modbus, ASCII protocols)
- A CANopen bus master link
- A second RS 485 serial link (SoMachine-Network, Modbus, ASCII protocols)

■ Model **TM238LFAC24DRS0**, powered with 100-240 V \sim offers:

- 14 x 24 V $\bar{\text{DC}}$ inputs, including 8 fast inputs, dedicated to special functions such as high-speed counting (HSC)
- 4 x 24 V $\bar{\text{DC}}$ solid state outputs, dedicated to HSC reflex functions, and 6 relay outputs (PWM and PTO functions not supported on these models)
- An RS 232/RS 485 serial link (SoMachine-Network, Modbus, ASCII protocols)
- A CANopen bus master link
- A second RS 485 serial link (SoMachine-Network, Modbus, ASCII protocols).
- The number of I/O can be expanded on all four models by adding up to 7 expansion modules (1) of the following type on the right-hand side of the base unit:
 - Digital **TM2DDI/DDO/DMM/DRA**
 - Analog **TM2AMI/ALM/ARI/AMO/AVO/AMM**
 - up to 3 High-speed counter **TM200HSC206DT/DF**

Modems or communication gateways can be connected to the serial links in order to expand the connectivity capability to include

- Ethernet Modbus/TCP,
- Profibus DP,
- DeviceNet,
- etc.

Note: A serial link on each controller delivers a 5 V $\bar{\text{DC}}$ voltage dedicated primarily to powering a Magelis display unit or Small panel terminal **XBTN•00/R400/RT500** or the Ethernet gateway **499TWD01100**.

The compact controller solution also has great flexibility in terms of wiring. With digital I/O expansion modules, several connection options are available, including removable screw terminals, spring terminals and HE 10 connectors, providing simple, quick, safe wiring. The Modicon Telefast ABE 7 prewiring system can be used for easy connection of expansion modules with HE 10 connectors.

(1) The addition of 7 expansion modules allows a maximum number per configuration of 136/192/248 I/O (depending on whether expansion modules with screw terminals, spring terminals or HE 10 connectors are being used).



TM238LFDC24DTS0



TM238LFAC24DRS0

3

Hardware control platforms

Modicon M238 logic controller

Compact base for Solutions with Application function Blocks (AFB)



SoMachine software platform

Presentation

Design and installation of Modicon M238 applications

Schneider Electric's **SoMachine** software platform is used to program Modicon M238 logic controllers for Solutions with AFB using:

- IEC 61131-3 programming languages: Instruction List (IL), Ladder Diagram (LD), Function Block Diagram (FBD), Sequential Function Chart/Grafset (SFC) and Structured Text (ST)
- CFC (Continuous Function Chart) language.

Access to the hoisting libraries including all the specialized AFB, see page 2/2..

Program loader

The **TM2USBABDEV1** program loader is an accessory which is designed to simplify updating or duplication of applications on Modicon M238 logic controllers without the need for a programming terminal.

- For updating: an application generated by SoMachine, stored on a USB memory stick, will be transferred by the program loader to an M238 controller.
- For duplication: an application is transferred from an M238 controller to the program loader. The application is stored on a USB memory stick, then transferred from the program loader to another M238 controller.

The front panel of the **TM2USBABDEV1** program loader features:

1. A USB port (marked PLC) for the connection cable to the mini-B USB port (marked Prg. Port) on the Modicon M238 logic controller.
2. A USB port (marked key) for the USB memory stick (holding the application).
3. An On/Off button to start the transfer.
4. Four operation LED indicators (PWR, COM, ERR, STS).



Compact base configuration

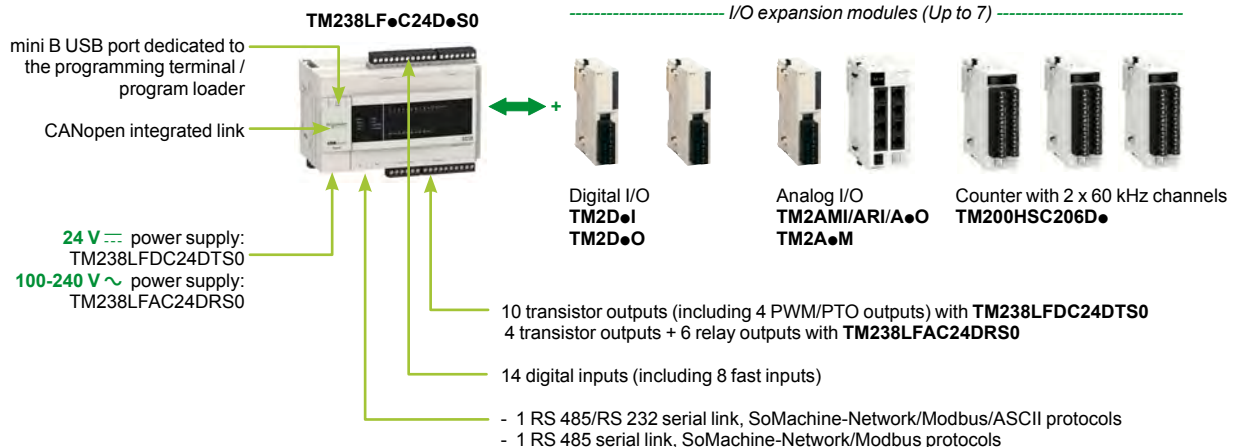

3

Hardware control platforms

Modicon M238 logic controller

Compact base for Solutions with Application function Blocks (AFB)

3

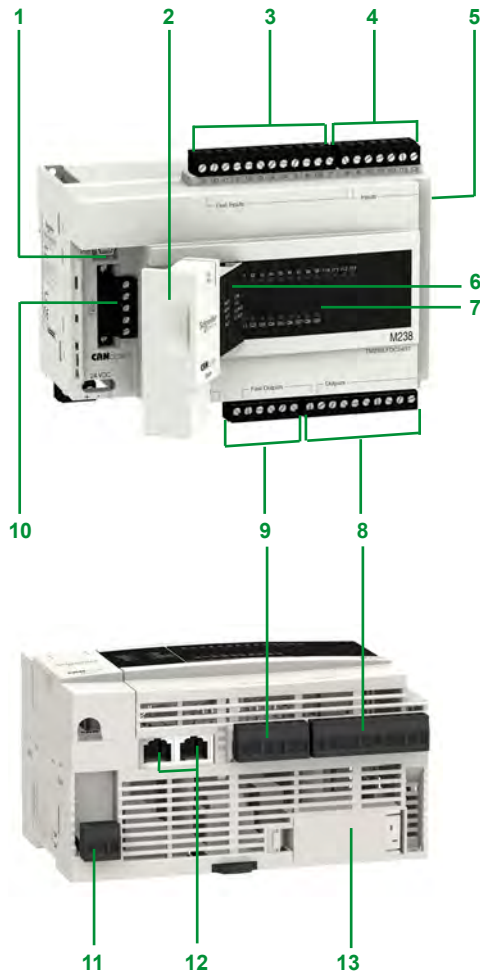

Description

The Modicon M238 logic controller base for Solutions with AFB **TM238LFDC24DTS0** and **TM238LFAC24DRS0** comprise:

- 1** A mini B USB connector, marked **Prg. Port**, for connecting a programming terminal
- 2** A hinged access cover with 2 cable glands (1 removable for the terminal cordset and 1 for the CANopen cable)
- 3** A removable screw terminal block (12 terminals) for connecting the sensors (24 V $\overline{\text{V}}$ fast inputs)
- 4** A removable screw terminal block (7 terminals) for connecting the sensors (24 V $\overline{\text{V}}$ inputs)
- 5** A connector for up to 7 digital **TM2D●●**, analog **TM2A●●** and up to 3 counter **TM200HSC206D●** I/O expansion modules
- 6** A display unit showing:
 - The controller status by means of 4 LEDs (PWR, RUN, Batt and Err)
 - The integrated communication port status by means of 4 LEDs (SL1, SL2, CAN Run and CAN Err)
- 7** A display unit showing the I/O states (I0...I13 and Q0...Q9)
- 8** A removable screw terminal block (10 terminals) for connecting 6 preactuators
- 9** A removable screw terminal block (6 terminals) for connecting 4 preactuators
- 10** A removable screw terminal block (5 terminals marked CANopen) for connection to the CANopen bus.

Accessible from the underside of the controller:

- 11** A removable screw terminal block (3 terminals):
 - +, -, $\overline{\text{V}}$ marked 24 VDC for connecting the 24 V $\overline{\text{V}}$ power supply
 - L, N, $\overline{\text{V}}$ marked 100-240 VAC for connecting the 100-240 V \sim power supply
- 12** 2 RJ45 connectors marked SL1 and SL2 for connecting the serial links
- 13** A hinged cover for accessing the RAM backup battery (optional) and the internal real-time clock

The compact bases are mounted as standard on a symmetrical \perp rail or on a metal plate (two \varnothing 4.3 holes).

Hardware control platforms

Modicon M238 logic controller

Compact base for Solutions with Application function

Blocks (AFB)



TM238LFDC24DT



TM238LFAC24DR



TSXPLP101

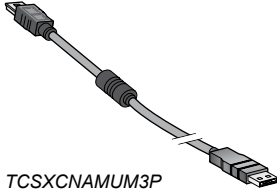

TCSXCNAMUM3P



TM200RSRCEMC



499TWD01100



SR2MOD03

References

Number of I/O	Inputs	Outputs	No. of I/O expansion modules	Integrated serial port	Integrated master CANopen port	Reference	Weight kg / lb
---------------	--------	---------	------------------------------	------------------------	--------------------------------	-----------	----------------

Compact base for solutions with AFB, 24 V $\overline{\text{DC}}$ power supply

24 I/O (removable battery to be ordered separately)	6 x 24 V $\overline{\text{DC}}$ inputs (sink/source) 8 x 24 V $\overline{\text{DC}}$ fast inputs (sink)	10 transistor outputs (source) including 4 fast	7 modules max.	1 RS 232/485 (marked SL1) 1 RS 485 (1) (marked SL2)		TM238LFDC24DTS0	0.595 / 1.312
---	---	---	----------------	--	--	-----------------	---------------

Compact base for solutions with AFB, 100-240 V \sim power supply

24 I/O (removable battery to be ordered separately)	6 x 24 V $\overline{\text{DC}}$ inputs (sink/source) 8 x 24 V $\overline{\text{DC}}$ fast inputs (sink)	4 transistor outputs (source) and 6 relay outputs	7 modules max.	1 RS 232/485 (marked SL1) 1 RS 485 (1) (marked SL2)		TM238LFAC24DRS0	0.595 / 1.312
---	---	---	----------------	--	--	-----------------	---------------

Separate parts

Designation	Use	Length Sold	Reference	Weight kg / lb
Removable backup batteries	Lithium thionyl chloride type for Modicon M238 compact bases	Individual	TSXPLP01	0.012 / 0.026
		Pack of 10	TSXPLP101	0.189 / 0.417

Programming cable	From the mini B USB port on the Modicon M238 compact bases to the type A USB port on the PC terminal for programming and updating firmware	3 m	TCSXCNAMUM3P	0.065 / 0.143
-------------------	--	-----	--------------	---------------

RS 232 serial link cordsets for DTE/DCE terminal device	1 RJ45 connector For DTE terminal (printer) and one 9-way SUB-D connector	3 m	TCSMCN3M4F3C2	0.150 / 0.331
	For DCE terminal (modem, converter)	3 m	TCSMCN3M4M3S2	0.150 / 0.331

Removable spring connectors for digital I/O	Set of 5 removable spring connectors. Replaces the 5 screw connectors supplied with Modicon M238 compact bases	–	TM238RSSPT	0.048 / 0.106
---	--	---	------------	---------------

Shielding connection clamps	Attachment and earthing of the cable shielding Pack of 25 clamps including 20 clamps for \varnothing 4.8 mm cable and 5 for \varnothing 7.9 mm cable	Pack of 25	TM200RSRCEMC	–
-----------------------------	--	------------	--------------	---

Modbus communication gateways	Connection of Modicon M238 compact bases to network/bus	Ethernet Modbus/TCP	(2)	499TWD01100	0.200 / 0.441
		Profibus DP	(3)	LUF P7	0.245 / 0.540
		DeviceNet	(3)	LUF P9	0.245 / 0.540

GSM/GPRS modem (DCE terminal)	4-band 900/1800 MHz (Europe) and 850/1900 MHz (United States) IP 31 casing supplied with: <input type="checkbox"/> 1.5 m power cable <input type="checkbox"/> SMA-M magnetic GSM 4-band aerial with 2.5 m cable <input type="checkbox"/> Fixed on panel or \perp 5.5...24 V $\overline{\text{DC}}$ supply voltage	–	SR2MOD03	0.335 / 0.739
-------------------------------	---	---	----------	---------------

Designation	Use From	To	Length	Reference	Weight kg / lb
Modbus cables equipped with 2 RJ45 connectors	Serial port marked SL1/SL2	Ethernet gateway 499 TWD 01100	2.5 m	XBZT9980	–
		Profibus DP LUF P7 or DeviceNet LUF P9, TSX CUSB 485 converter	1 m	VW3A8306R10	0.050 / 0.110
			3 m	VW3A8306R30	0.150 / 0.331
			0.3 m	VW3A8306R03	0.030 / 0.066

(1) RS 485 link delivering a 5 V $\overline{\text{DC}}$ /200 mA power supply.

(2) Connection to serial port SL1 on controller TM238LDA24DRS0 or to serial port SL2 on controller TM238LFAC24DRS0 via Modbus cable XBZT9980 (to be ordered separately).

(3) Connection to serial port SL1 on controller controller TM238LDA24DRS0, to serial port SL1 or SL2 on controllers TM238LFAC24DRS0 via Modbus cable VW3A8306 R●● (to be ordered separately). Requires a 24 V $\overline{\text{DC}}$ external power supply.

Gateway configurable via the ABC Config Tool software, downloadable from our website www.schneider-electric.com

Hardware control platforms

Modicon M238 logic controller

Compact base for Solutions with Application function Blocks (AFB)



HMIZSUSBB



TM2USBABDEV1



TSXCUSB485

References

Accessories

Designation	Description	Length	Reference	Weight kg lb
Remote location of the USB port for M238 controllers and XBTGT2●●0...GT7340, GT1●●5, GK●●●, GTW●●● terminals	Used to locate the USB port of M238 controllers (front) and XBTG terminals (rear) remotely on panel or enclosure door (Ø 21 mm (3.281 in.) mounting device)	1 m 3.281 ft	HMIZSUSBB	0.100 0.220
Program loader	Used to update and duplicate applications. Requires the use of a USB memory stick (not supplied)	3 m 9.843 ft (cable)	TM2USBABDEV1	0.250 0.551

Connection elements for RS 485 OS download port for M238 version V1.0 (1)

Designation	Use	Length	Reference	Weight kg lb
USB/RS 485 converter	Used to connect the RS 485 port (SL1) to the USB port on the PC to update the controller operating system. Requires Modbus cable VW3 A8 306 R●● for the connection at the controller end	0.4 m 1.312 ft (integrated cable at PC end)	TSXCUSB485	0.144 0.317

Replacement parts

Designation	Use	Reference	Weight kg lb
Removable screw connectors , supplied with Modicon M238 bases	Set of 5 removable screw connectors for digital I/O	TM238RSSCT	0.055 0.121
	One 5-way connector with line terminator for CANopen link	TM238CNTLSCT	0.010 0.022

(1) For later versions, use the USB port and cable.

Memory structure

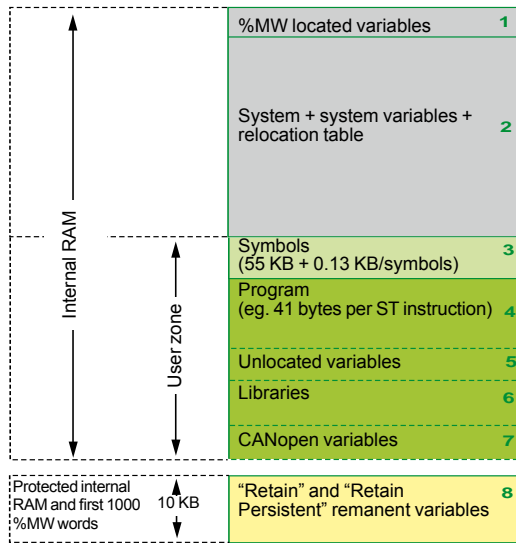

Modicon M238 controllers offer great flexibility in memory management. Depending on the model used, they have a user memory zone of 1024 KB with **TM238LFDC24DTS0** and **TM238LFAC24DRS0** bases.

This user memory zone is divided according to the application program requirements and the volume needed by the symbols, unlocated variables and libraries required by the application. The memory structure of Modicon M238 controllers is shown opposite.

The table below lists the maximum memory capacities depending on the model (values are given for information only).

		TM238LFDC24DTS0, TM238LFAC24DRS0
Internal RAM	KB	2048
1 Located variables	KB	120 (60,000 %MW)
2 System + system variables + relocation table	KB	900
User zone	KB	1000
3 Symbols	KB	200 (max. 1000 symbols)
4 Program (including online program modification)		As required by the application, within the limits of the size of the user zone
5 Unlocated variables		
6 Libraries		
7 CANopen variables	KB	115 + 10 per slave
Protected internal RAM	KB	10
8 "Retain" variables	Bytes	8168
8 "Retain Persistent" variables	Bytes	400
8 First 1000 %MW words	Bytes	2000

Storing variables

Remanent variables can be one of two types depending on their declaration in the application:

"Retain" variables, 8168 bytes maximum

"Retain Persistent" variables, 400 bytes maximum.

The first 1000 located variables 1 (first 1000 %MW words) and all the unlocated variables 5 configured as "Retain" and "Retain Persistent" type are backed up by the internal battery or by the optional external battery. They are maintained when the power returns if the startup context allows this (see "Restart context" below).

In addition, "Retain Persistent" type variables are maintained on a change of application if the startup context allows this (see "Restart context" below).

Restart context

The state of the remanent memory before disconnection is restored on the next power-up when the internal battery and/or the optional external battery is/are capable of protecting the internal RAM (no memory checksum error).

If the internal battery or optional external battery does not have enough charge to back up the internal RAM, the values of the "Retain" and "Retain Persistent" remanent variables are reset to 0.

In SoMachine V3, a new option accessible by configuration allows the choice of 3 modes to restart after powering off the controller; run / stop / original state when powered off. In this third case, the optional battery is required in case of powering off more than three days (autonomy of the battery after an initial charge of 22 hours). If there is no optional battery, the controller will start in the stop mode after a three-day power off.

The external battery can be monitored by the *GetBatteryLevel* software function, and its charging status is visible from the status of the Batt LED on the front of the controller.

Storing the program

Regardless of the context and status of the internal battery and/or optional external battery, the program is backed up in the Flash RAM during the "boot application" creation procedure (SoMachine software procedure).

Hardware control platforms

Modicon M258 logic controller

Compact base for Solutions with Application function Blocks (AFB)

Applications

Control solutions for

- Packaging
- Conveying
- Hoisting
- Pumping
- ...

42 digital I/O

42 digital I/O + 4 analog inputs



3

User memory RAM
Flash

64 MB (program + data)
128 Mbytes

Typical Boolean instruction time

22 ns

User program size

128 program K instructions

Power supply

24 V $\bar{\text{---}}$

Channel connection

With removable spring terminal blocks (supplied)

Inputs Digital
Analog

26 x 24 V $\bar{\text{---}}$ inputs including 8 counter inputs (100 kHz)
– 4 inputs
+ 10 V/- 10 V, 4-20 mA/0-20 mA, 12-bit resolution

Digital outputs Transistor
Relay

16 outputs (0.5 A) including 4 reflex outputs
–

Built-in communication ports USB-B mini-port
USB-A port
RJ45 port (MBS)
SUB-D connector (male 9-way) (CAN0)
RJ45 port (Ethernet)

Programming port for SoMachine software
Connection of a USB memory stick for transferring programs, data files, firmware updates
RS232 serial link,
RS485 serial link (supplies 250 mA, 5 V for HMI power supply)
Protocols: Master/Slave Modbus ASCII/RTU, ASCII (character string)
Master CANopen bus (63 slaves)
Ethernet TCP IP, Web Server, FTP, Ethernet Modbus TCP | Ethernet TCP IP Modbus slave, Web Server, FTP

Optional communication ports

– 2 PCI slots available on controller for optional communication modules TM5 PC $\bullet\bullet\bullet$ (1):
 Modbus or ASCII serial link
 connection to Profibus DP bus (slave)

Logic controller type

TM258 LF42DTS0

TM258 LF42DT4LS0

Page

3/32



42 digital I/O**66 digital I/O
+ 4 analog inputs**

64 MB (program + data)

128 Mbytes

22 ns

128 program K instructions

24 V $\overline{\text{---}}$

With removable spring terminal blocks (supplied)

26 x 24 V $\overline{\text{---}}$ inputs including 8 counter inputs (100 kHz)

–

4 reflex outputs (0.5 A)

12

38 x 24 V $\overline{\text{---}}$ inputs including 8 counter inputs (100 kHz)4 inputs
+ 10 V/- 10 V, 4-20 mA/0-20 mA,
12-bit resolution

28 outputs (0.5 A) including 4 reflex outputs

–

Programming port for SoMachine software

Connection of a USB memory stick for transferring programs, data files, firmware updates

RS232 serial link,
RS485 serial link (supplies 250 mA, 5 V for HMI power supply)
Protocols: Master/Slave Modbus ASCII/RTU, ASCII (character string)

Master CANopen bus (63 slaves)

Ethernet TCP IP Modbus slave, Web Server, FTP

2 PCI slots available on controller for optional communication modules TM5 PC●●● (1):

- Modbus or ASCII serial link
- connection to Profibus DP bus (slave)

TM258 LF42DRS0**TM258 LF66DT4LS0**

3/32

(1) To be ordered separately, see page 4/8.

Hardware control platforms

Modicon M258 logic controller

Compact base for Solutions with Application function Blocks (AFB)



Modicon M258 logic controller for Solutions with AFB

3

The Modicon M258 logic controller is the compact base for Solutions with AFB using pre-defined AFB libraries, high-performance and fully expandable PLC. It forms a part of Flexible Machine Control approach, a key component of MachineStruxure™, which brings you maximum flexibility and ensures the most optimised control solution. This PLC is designed for machine manufacturers focusing on applications such as packaging, conveying and storage, textiles and woodworking, hoisting, etc. It offers high-performance solutions for speed control, counting, axis control and communication functions.

Performance

In terms of performance, the Modicon M258 logic controller has a Dual-Core processor:

- Core 1 is dedicated exclusively to managing program tasks and offers the maximum resources for real-time execution of the application code.
- Core 2 is dedicated to executing communication tasks, which then have no further impact on the application execution performance.

With an execution speed of **22 ns** for a Boolean instruction i.e. more than **45,000 Boolean instructions** per ms, the capacity to manage up to **2400 I/O**, a **64 MByte** RAM memory that can store data and programs as well as a **128 MByte** Flash memory for application and data backup, the Modicon M258 logic controller eliminates any doubts about the machine's limits.

In developing the Modicon M258 logic controller, the cost aspect was taken into account, the CPUs are equipped as standard with:

- 42 or 66 digital I/O
- Embedded serial link and Ethernet port
- 4 analog inputs (TM258●●●●4L references)

Development and technology

In all its characteristics, the Modicon M258 logic controller has been developed to minimize the costs of assembly, cabling, commissioning and maintenance. To this end:

- All the modules have removable terminals.
- All the electrical connections are made on spring terminals, speeding up the wiring process and also avoiding the need for periodic retightening. In addition, each terminal has a test point for a voltage sensing device.
- The embedded serial link and Ethernet port on the Modicon M258 logic controller have an RJ45 connection at 45° for quick visible connection of your communication channels.
- The modularity of the various bases and expansion modules has been optimized in order to reduce significantly the number of references to be ordered and assembled, while ensuring the minimum investment in your configuration is necessary, thanks to a capacity of 2 to 42 channels per expansion module.
- Mechanical assembly of the various parts has been designed to save a considerable amount of time during assembly.

Software configuration

Configuration and programming of all M258 logic controllers for Solutions with AFB and equipment in Schneider Electric's "Flexible Machine Control" concept are both designed to cut costs and optimize machine performance.

Schneider Electric's **SoMachine** software platform can be used to program M258 logic controllers for Solutions with AFB using:

- IEC 61131-3 programming languages: Instruction List (IL), Ladder Diagram (LD), Function Block Diagram (FBD), Sequential Function Chart/Grafcet (SFC) and Structured Text (ST)
- CFC (Continuous Function Chart) language.

PLCopen function blocks are used for managing motion control and axis control on your machines.

Access to the hoisting libraries including all the specialised AFB, see page 2/2.

Integration in the Schneider Electric product offer

Combined with other products dedicated to machine manufacturers in the Schneider Electric offer, such as ATV variable speed drives, Lexium servo drives, Magelis HMI terminals, TeSys motor starters and contactors, the Modicon M258 logic controller is now a must-have element in machine architectures, with hitherto unrivalled ease and speed of installation.



SoMachine software platform

Hardware control platforms

Modicon M258 logic controller

Compact base for Solutions with Application function Blocks (AFB)

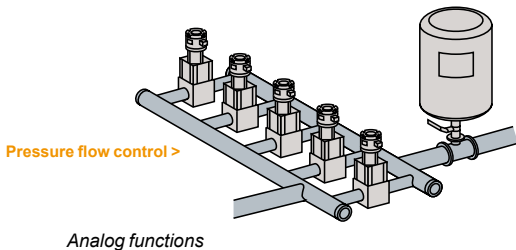

Functions

Analog functions

For machines that require functions to process data issued by analog sensors/ actuators (voltage or current), temperature sensors or PID control sensors, a complete range of expansion modules as well as advanced programming functions are included in the Modicon M258 logic controller for Solutions with AFB offer. In order to minimize the number of product references of your machines, optimize assembly time and cut costs, all M258 logic controllers for Solutions with AFB with the reference **TM258LF●●●4LS0** include as standard 4 voltage or current analog inputs with 12-bit resolution.

The different expansion modules are available in 2, 4, 6 or 8-channel versions and with either 12 or 16-bit resolution.

The powerful performance of the M258 logic controller for Solutions with AFB enables up to 200 analog I/O and/or temperature modules to be connected, thus extending the limits of machine requirements.

High-speed counter function (HSC)

In order to meet requirements for machine productivity, the Modicon M258 logic controller for Solutions with AFB has 8 embedded high-speed counters with a counting frequency of 100 kHz for each channel as well as 4 reflex outputs. The availability of these embedded counters and also the presence of the Master CANopen link in **TM258LF●●●●S0** logic controllers for Solutions with AFB makes it quick and easy to create low-cost, high-performance multi-axis functions that suit the machines' limitations.

With the availability of "PLCopen" function blocks specific to the motion control functions in the SoMachine software, you can be sure that developing your applications will be quick and reliable.

Moreover, a complete range of high-speed counter modules is available so you can adapt your configuration to your machine's specific requirements.

Communication functions

Ethernet

All M258 logic controller for Solutions with AFB references have an embedded RJ45 Ethernet port (10/100 Mbps, MDI/MDIX) with Ethernet TCP Modbus, Ethernet IP Device, SoMachine on Ethernet, UDP, TCP and SNMP protocols.

In addition, all the M258 logic controllers for Solutions with AFB have an embedded Web Server and FTP Server.

As well as the default address based on the MAC address, it is possible to assign a controller IP address via a DHCP server or via a BOOTP server.

CANopen

Depending on the reference, M258 logic controllers for Solutions with AFB have an embedded CANopen master.

The link can be configured between 125 Kbps and 1 Mbps and supports up to 63 slaves.

Architectures based on CANopen can be used to distribute I/O modules as close to the sensors and actuators as possible, thus reducing wiring costs and times, and to communicate with different devices such as variable speed drives, servo drives, etc. The CANopen configurator is integrated in the SoMachine software and can also be used to import standard description files in EDS format.

Modbus serial link

All M258 logic controllers for Solutions with AFB have as standard a serial link that can be configured as either RS232/RS485 and incorporates the two most commonly used protocols on the market:

- Master or Slave Modbus ASCII/RTU
- Character string (ASCII)

Profibus DP (Decentralized Peripherals)

The Modicon **TM258LF42DT4LS0**, **TM258LF42DRS0** and **TM258LF66DT4LS0** logic controllers equipped with the **TM5PCDPS** communication module can be connected to Profibus bus: for controlling decentralized sensors, actuators or PLCs via a central master controller

Hardware control platforms

Modicon M258 logic controller

Compact base for Solutions with Application function Blocks (AFB)



TM258LF42DTS0 logic controller for Solutions with AFB



TM258LD42DT4LS0 logic controller for Solutions with AFB

TM5PC communication modules



TM5C compact blocks



TM5SD digital modules



TM5SMM6D2L digital/Analog module



TM5SA and TM5SEAISG analog modules



TM5SE Expert modules



TM5SPD Common Distribution modules



TM5SPS Power Distribution modules



TM5SBET1 transmitter module



TM5SBER2 receiver module

Presentation

Range

The M258 logic controller for Solutions with AFB range is divided into two controller sizes:

- TM258LF42DTS0 is 175 mm wide.
- TM258LF42DTS0, TM258LF42DT4LS0, TM258LF42DRS0 and TM258LF66DT4LS0 are at least 237.5 mm wide as they have two free PCI slots for optional Modicon TM5 communication modules (Modbus or ASCII serial link, and connection to Profibus DP bus).

The M258 logic controller for Solutions with AFB range is completed by an expansion module offer:

- Modicon TM5 Compact blocks
- Modicon TM5 Digital modules
- Modicon TM5 Digital/Analog module
- Modicon TM5 Analog modules
- Modicon TM5 Expert modules
- Modicon TM5 Common Distribution modules
- Modicon TM5 Power Distribution modules
- Modicon TM5 Transmitter and receiver modules

Functions

The main component in a system is the controller: 4 M258 logic controller for Solutions with AFB models are offered to cover different control requirements (pressure, temperature, counting, speed, position control, motion, etc.).

M258 logic controller for Solutions with AFB and I/O modules are programmed with the SoMachine software.

Reference	Embedded functions
TM258LF42DTS0, TM258LF42DT4LS0, TM258LF42DRS0, TM258LF66DT4LS0	<ul style="list-style-type: none"> ■ 42 or 66 digital I/O including 8 high-speed counters (100 kHz) ■ Depending on the reference, 4 voltage/current analog inputs can be added ■ Up to 16 independent axes ■ CANopen master

All M258 logic controllers for Solutions with AFB have two groups of high-speed I/O with, for each group:

- Four sink type high-speed inputs (up to 100 KHz), 2 standard inputs and 2 source type high-speed outputs (up to 100 KHz) dedicated to HSC or PWM functions
- A high-speed input which can be used as an "Encoder capture input"
- Two commons for the inputs
- One common for the outputs
- A power supply (24 V \pm) consisting of 3 units:
 - One for the CPU
 - One for the high-speed I/O modules
 - One for other modules (internal I/O Bus)

Conformity to standards

Type		Performance
Surge immunity 24 VDC circuit	EN/IEC 61000-4-5	1 kV in common mode
		0.5 kV in differential mode
Surge immunity 230 VAC circuit	EN/IEC 61000-4-5	2 kV in common mode
		1 kV in differential mode
Induced electromagnetic field	EN/IEC 61000-4-6	10 Veff (0.15...80 MHz)
Conducted emission	EN 55011 (IEC/CISPR11)	150...500 kHz, quasi peak 79 dB μ V
		500 kHz...30 MHz, quasi peak 73 dB μ V
Radiated emission	EN 55011 (IEC/CISPR11)	30...230 MHz, 10 m @ 40 dB μ V/m
		230 MHz...1 GHz, 10 m @ 47 dB μ V/m

3

Hardware control platforms

Modicon M258 logic controller

Compact base for Solutions with Application function Blocks (AFB)

Assembly and mounting

The components of this system have been designed for simple interlocking mechanical assembly.

An 8-way expansion bus connection (2 for the power supply, 2 for the bus and 4 for the data) is used to distribute data and the power supply when assembling the components: the M258 controller with compact blocks and modules (digital, digital/analog, analog, Expert, common distribution, power distribution, expansion bus). All the elements which make up the system are mounted and dismantled on a symmetrical rail using the locking levers located on top of each device.

Wiring and maintenance of devices is simplified since they are fitted with removable spring terminals. The spring terminals are undone by pressing a locking tab.

The system is integrated into communication networks: all the connectors (RJ45, USB, mini-USB and SUB-D type depending on the model) are accessible, as they are located on the controller front panels.

Local or remote architecture

Local I/O

A PLC configuration can be local or remote. It consists of an M258 controller with its embedded input and output channels, used in conjunction with compact blocks and/or modules which are used to increase the number of channels and/or "Application-specific" functions.

- Compact blocks represent a way of adding a large number of I/O with a single reference. This possibility reduces both the cost per channel, and also assembly times. These compact blocks are available in 4 references offering a high level of flexibility in configurations.

- I/O modules (a combination of a bus base, an electronic module and a terminal block) complete this configuration and, being modular with between 2 and 12 channels, make it possible to adjust the number of channels to exactly that required. Addition of digital or analog modules, temperature or high-speed modules increases the processing capabilities of applications.

Configuration of local I/O

- 1 XBTGT supervision graphic touch screen terminal
- 2 M258 controller for Solutions with AFB
- 3 Compact blocks or I/O modules

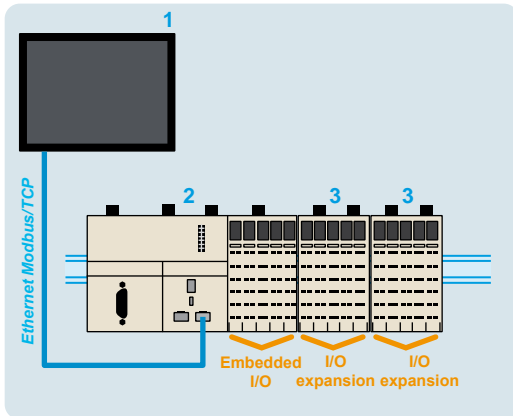

Local I/O

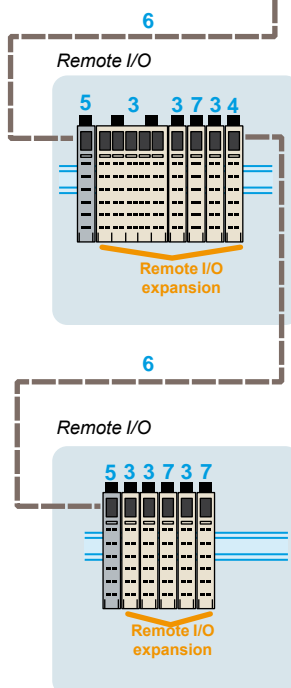
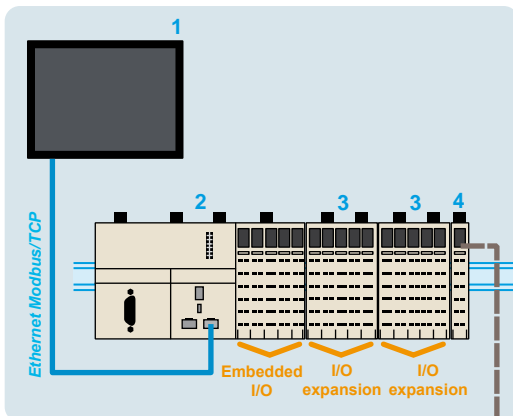

Remote I/O

Because of its backplane bus management, the TM5 system can be used to control I/O remotely.

The same modules can be used in either a local and/or remote configuration, linked together with expansion bus cables.

The total maximum distance between 2 remote islands is 100 m and the maximum number of islands is 25, i.e. a total distance of up to 2500 m.

This function ensures a high level of flexibility, while retaining **synchronization of all data acquisition**, since all the expansion modules are on the same backplane bus.

Configuration of remote I/O

- 1 XBTGT supervision graphic touch screen terminal
- 2 M258 controller for Solutions with AFB
- 3 Compact blocks or I/O modules
- 4 Transmitter modules
- 5 Receiver modules
- 6 TM5 expansion bus cables
- 7 Common distribution modules



Hardware control platforms

Modicon M258 logic controller

Compact base for Solutions with Application function Blocks (AFB)

3

Communication

M258 logic controllers for Solutions with AFB have the following built-in communication ports:

References	Communication ports	Use
TM258LF42DTS0, TM258LF42DT4LS0, TM258LF42DRS0, TM258LF66DT4LS0	1 x RJ45 Configurable as RS232 or RS485	ASCII or RTU exchange with Modbus communication protocol
	1 x RJ45 (MDI/MDIX port)	<input type="checkbox"/> FTP server <input type="checkbox"/> Web server <input type="checkbox"/> Modbus TCP server <input type="checkbox"/> Modbus TCP client <input type="checkbox"/> Manager SoMachine <input type="checkbox"/> SNMP <input type="checkbox"/> Ethernet IP device <input type="checkbox"/> Modbus device
	1 x USB-A	Connection of a USB memory stick for transferring (uploading/ downloading) programs, data and/ or firmware
	1 x mini-USB	Programming port (480 Mbps)
	1 x 9-way male SUB-D	Master CANopen connection
	2 PCI slots for communication modules = 2 x 9-way male SUB-D	Addition of optional communication modules for a serial link and a connection on the bus Profibus DP (1)

Embedded Ethernet

M258 logic controllers for Solutions with AFB have an embedded Ethernet link via a direct connection to their RJ45 port.

- Speed: "10 BaseT" and "100 BaseTX" with auto-negotiation
- RJ45 port (MDI/MDIX): automatic adaptation to a straight or crossed cable

References	Protocols	Number of connections
TM258LF42DTS0, TM258LF42DT4LS0, TM258LF42DRS0, TM258LF66DT4LS0	Modbus server	8
	Modbus device	2
	SoMachine	3 (2)
	Ethernet IP device	16
	FTP server	4
	Web server	10

(1) Only on TM258LF42DT4LS0, TM258LF42DRS0 and TM258LF66DT4LS0.

(2) The Oscilloscope function uses one connection

Hardware control platforms

Modicon M258 logic controller

Compact base for Solutions with Application function Blocks (AFB)

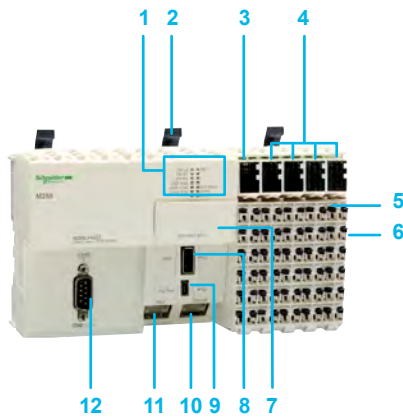

Description

The **TM258LF42DTS0** logic controller for Solution comprises:

- 1 A display block with:
 - 4 controller status LEDs (RUN/MS, BATTERY, APP0 and APP1)
 - 6 built-in communication port status LEDs (*Eth* LA, *Eth* ST, *Eth* NS, USB Host, MBS COM, CAN 0 STS)
- 2 Locking lever for mounting/dismounting on \perp symmetrical rail.
- 3 A 24 V $\overline{\text{DC}}$ power supply module with removable terminal block and locking lever, display block and slot for a label.
- 4 I/O modules, each one with: a removable terminal block with locking lever, a display block showing the I/O states and a slot for a label-holder.
- 5 Removable terminal block with locking lever for locking/unlocking.
- 6 On the side, an expansion bus connection for the link with the next module.
- 7 A slot for the RTC (Real Time Clock) battery.
- 8 A USB-A connector (marked Host) for connection of a USB memory stick for transferring programs, data or firmware updates.
- 9 A USB-B mini-connector (marked Pgr Port) for connection to the programming PC.
- 10 An RJ45 connector (marked Ethernet) for connection to the Ethernet network and/or connection to the Magelis XBTGT graphic terminal.
- 11 An RJ45 connector (marked MBS) for the RS232 or RS485 serial link.
- 12 A 9-way male SUB-D connector, marked CAN 0, for connection to the CANopen bus.

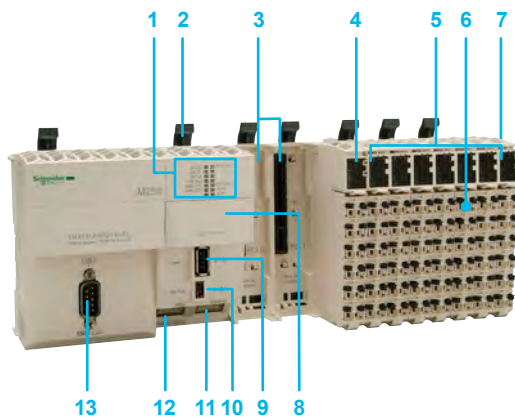

The **TM258LF42DT4LS0 / LF42DRS0 / LF66DT4LS0** logic controllers for Solutions with AFB comprise:

- 1 A display block with:
 - 4 controller status LEDs (RUN/MS, BATTERY, APP0 and APP1)
 - 6 built-in communication port status LEDs (*Eth* LA, *Eth* ST, *Eth* NS, USB Host, MBS COM, CAN 0 STS)
- 2 Locking lever for mounting/dismounting on \perp symmetrical rail.
- 3 Two free PCI slots for the communication module.
- 4 A 24 V $\overline{\text{DC}}$ power supply module with removable terminal block and locking lever, display block and slot for a label.
- 5 I/O modules, each one with: a removable terminal block with locking lever, a display block showing the I/O states and a slot for a label-holder.
- 6 Removable terminal block with locking lever for locking/unlocking.
- 7 On the side, an expansion bus connection for the link with the next module.
- 8 A slot for the RTC (Real Time Clock) battery.
- 9 A USB-A connector (marked Host) for connection of a USB memory stick for transferring programs, data or firmware updates.
- 10 A USB-B mini-connector (marked Pgr Port) for connection to the programming PC.
- 11 An RJ45 connector (marked Ethernet) for connection to the Ethernet network and/or connection to the Magelis XBTGT graphic terminal.
- 12 An RJ45 connector (marked MBS) for the RS232 or RS485 serial link.
- 13 A 9-way male SUB-D connector, marked CAN 0, for connection to the CANopen bus.

Hardware control platforms

Modicon M258 logic controller

Compact base for Solutions with Application function Blocks (AFB)

References

Logic controllers, Compact base for solutions with AFB, 24 V $\overline{\text{V}}$ power supply (1)

Nbr. of I/O	Inputs	Outputs	Built-in communication ports	Reference	Weight kg lb
42 I/O	<ul style="list-style-type: none"> 26 x 24 V $\overline{\text{V}}$ digital inputs including 8 counter inputs (100 kHz) 	<ul style="list-style-type: none"> 16 transistor digital outputs (0.5 A) including 4 reflex outputs 	<ul style="list-style-type: none"> 1 RJ45 port: Ethernet 1 SUB-D port (9-way male): CANopen master 1 USB-A port: program transfer 1 USB-B mini-port: software programming 1 RJ45 port: RS232/RS485 serial link 	TM258LF42DTS0	0.550 1.213
42 + 4 I/O	<ul style="list-style-type: none"> 26 x 24 V $\overline{\text{V}}$ digital inputs including 8 counter inputs (100 kHz) 4 analog inputs 10 V/- 10 V, 4-20 mA/0-20 mA, 12-bit resolution 	<ul style="list-style-type: none"> 16 digital transistor outputs (0.5 A) including 4 reflex outputs 	<ul style="list-style-type: none"> 1 RJ45 port: Ethernet 1 SUB-D port (9-way male): CANopen master 1 USB-A port: program transfer 1 USB-B mini-port: software programming 1 RJ45 port: RS232/RS485 serial link + 2 free PCI slots for optional communication modules (2): RS232/RS485 serial link and Profibus DP bus 	TM258LF42DT4LS0	0.770 1.698
42 I/O	<ul style="list-style-type: none"> 26 x 24 V $\overline{\text{V}}$ digital inputs including 8 counter inputs (100 kHz) 	<ul style="list-style-type: none"> 4 digital transistor (reflex) outputs (0.5 A) 12 relay outputs 	<ul style="list-style-type: none"> 1 RJ45 port: Ethernet 1 SUB-D port (9-way male): CANopen master 1 USB-A port: program transfer 1 USB-B mini-port: software programming 1 RJ45 port: RS232/RS485 serial link + 2 free PCI slots for optional communication modules (2): RS232/RS485 serial link and Profibus DP bus 	TM258LF42DRS0	0.800 1.764
66 + 4 I/O	<ul style="list-style-type: none"> 38 x 24 V $\overline{\text{V}}$ digital inputs including 8 counter inputs (100 kHz) 4 analog inputs + 10 V/- 10 V, 4-20 mA/0-20 mA, 12-bit resolution 	<ul style="list-style-type: none"> 28 digital transistor outputs (0.5 A) including 4 reflex outputs 	<ul style="list-style-type: none"> 1 RJ45 port: Ethernet 1 SUB-D port (9-way male): CANopen master 1 USB-A port: program transfer 1 USB-B mini-port: software programming 1 RJ45 port: RS232/RS485 serial link + 2 free PCI slots for optional communication modules (2): RS232/RS485 serial link and Profibus DP bus 	TM258LF66DT4LS0	0.800 1.764



TM258LF42DTS0



TM258LF42DT4LS0



TM258LF42DRS0



TM258LF66DT4LS0

(1) The Modicon M258 logic controllers type S Solutions with AFB require a power supply with a nominal voltage of 24 V $\overline{\text{V}}$. The 24 V $\overline{\text{V}}$ power supply must be rated Separated Extra Low Voltage (SELV-rated) according to IEC 61140. The SELV-rating means that SELV isolation is provided between the electrical input and output of the power supply.

(2) To be ordered separately see page 4/8.

Hardware control platforms

Modicon M258 logic controller

Compact base for Solutions with Application function

Blocks (AFB)

References

Accessories

Type	Used for	Colour	Sold in lots of	Unit reference	Weight kg lb
Plain text cover holder (label-holder)	Marking the terminal blocks on the I/O channels	Transparent	100	TM5ACTCH100	0.002 0.004
Plain text cover holder locking clip (Order with plain text cover holder TM5ACTCH100)	Locking plain text cover holder TM5ACTCH100	Transparent	100	TM5ACTLC100	0.001 0.002
Precut legend strips of paper	Plain text cover holder TM5ACTCH100	White	100	TM5ACTLS100	0.001 0.002
Coloured plastic identifiers	Labelling 16 connection channel terminals	White	1	TM5ACLITW1	0.015 0.033
		Red	1	TM5ACLITR1	0.015 0.033
		Blue	1	TM5ACLITB1	0.015 0.033
Metal tool	Inserting/removing TM5 ACLIT●1 identifiers	Black	1	TM5ACLT1	0.030 0.066

Connection cables

Description	Use from	to	Length	Reference	Weight kg
Software programming cable Baud rate: 480 Mbps max. Protocol: Modbus, HTTP, FTP, Codesys or virtual, non-isolated	PC USB port	USB mini-port on M258 controllers	3 m 9.843 in.	TCSXCNAMUM3P	0.065 0.143
RS485 serial link cables Modbus protocol	SUB-D port (25-way) on Small Panel compact display units: XBTN401, XBTN410, XBTR410, XBTR411, XBTGT2... GT7	RJ45 port on M258 controllers	1.8 m 5.906 in.	XBTZ938	0.230 0.507
		RJ45 port on XBTGT graphic touch screen terminals	2.5 m 8.220 in.	XBT9980	0.230 0.507
RS232 serial link cables Character mode	SUB-D port (9-way female) on DTE equipment (1): printer, hand-held bar code reader, etc.	RJ45 port on M258 controllers	3 m 9.843 in.	TCSMCN3M4F3C2	0.150 0.331
		RJ45 port on M258 controllers	3 m 9.843 in.	TCSMCN3M4M3S2	0.150 0.331

(1) DTE: Data Terminal Equipment.

(2) DCE: Data Communication Equipment.



TM5ACTLC100



TM5ACTCH100

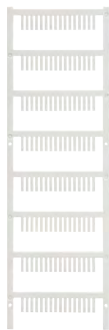

TM5ACLITW1



TM5ACLT1

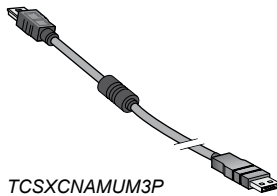

TCSXCNAMUM3P

Hardware control platforms

I/O expansion modules for Hardware platform control

Local and remote I/O expansion modules
Distributed I/O expansion modules

3

Local and remote I/O expansion modules

Applications	
Compatibility	
I/O type	
Remote I/O configuration	Hardware
Bus type	

Local I/O (IP 20)	
<ul style="list-style-type: none"> Modicon M238 logic controller type S Solutions with AFB XBTGC HMI controllers Modicon OTB 	
Digital	Analog
–	–
–	–



Inputs	Number (depending on model)	4 to 32 inputs	2 to 8 inputs
	Type (depending on model)	24 V $\overline{\text{DC}}$ 120 V \sim	Voltage, Current, Temperature
Outputs	Number (depending on model)	8 to 32 outputs	1 to 2 outputs
	Type (depending on model)	24 V $\overline{\text{DC}}$ transistor, Relay	0...10 V, \pm 10 V, 4...20 mA

Type of expansion module	Modicon TM2 digital module	Modicon TM2 analog module
More information	Please consult on our web site www.schneider-electric.com	
(1) Modicon TM5 transmitter/receiver modules, please consult our web site www.schneider-electric.com		

Distributed I/O expansion modules



Applications	
Compatibility	

Optimum distributed I/O (IP 20)
<ul style="list-style-type: none"> Modicon M238 logic controller type S Solutions with AFBs XBTGC HMI controller Altivar IMC drive controller card type S solutions with AFB



Available buses and networks	
Configuration with I/O expansion modules	Module type
	Capacity
Integrated I/O	Number and type (depending on model)
Type of distributed I/O expansion module	
More information	

<ul style="list-style-type: none"> Ethernet Modbus TCP/IP CANopen bus Modbus serial link (RS 485)
Modicon TM2: <ul style="list-style-type: none"> Digital I/O modules Analog I/O modules Common distribution modules
For 1 Modicon OTB interface module: 7 Modicon TM2 modules max. including: <ul style="list-style-type: none"> Digital I/O modules: <ul style="list-style-type: none"> 132 I/O max. with modules with screw terminals 188 I/O max. with modules with spring terminals 244 I/O max. with modules with HE10 connector Analog I/O modules with screw terminals: up to 7 x 8 inputs, or 7 x 2 outputs, or 7 x (4I/2O) Common distribution module
12 x 24 V $\overline{\text{DC}}$ digital inputs 2 x 24 V $\overline{\text{DC}}$ solid state outputs 6 x 30 V $\overline{\text{DC}}$ /240 V \sim relay outputs 2 channels: 5 kHz/20 kHz 2 PWM function channels
Modicon OTB interface modules
Please consult on our web site www.schneider-electric.com

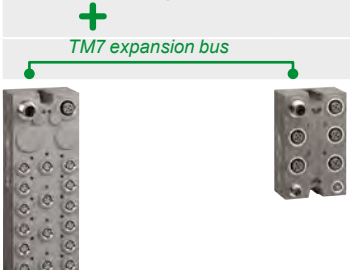
Local and/or remote I/O (IP 20)			Remote I/O expansion bus (IP 67)	
■ Modicon M258 logic controller type S Solutions with AFB			■ Modicon M258 logic controller type S Solutions with AFBs	
Digital	Analog	Digital/analog	Digital	Analog
 <p>Modicon TM5 transmitter/receiver: For use with remote I/O (1)</p>			 <p>Modicon TM5 transmitter/receiver: Required (1)</p>	
 <p>TM5 expansion bus</p>			 <p>TM7 expansion bus</p>	
2 to 12 inputs	2 to 6 inputs	Digital: 12 to 14 inputs Analog: 4 inputs	8 to 16 inputs	2 to 4 inputs
24 V $\overline{\text{DC}}$ 100/120 V \sim , 100/240 V \sim	Voltage, Current, Temperature	Digital: 24 V $\overline{\text{DC}}$ Analog: Voltage, Current	24 V $\overline{\text{DC}}$	Voltage, Current, Temperature Resistance
2 to 12 outputs	2 to 4 outputs	Digital: 6 to 18 outputs Analog: 2 outputs	8 to 16 outputs	2 to 4 outputs
24 V $\overline{\text{DC}}$ 30/230 V \sim , 100/240 V \sim	- 10...+ 10 V, 0...20 mA	Digital: 24 V $\overline{\text{DC}}$ Analog: Voltage/Current	24 V $\overline{\text{DC}}$ Transistor/Source	- 10...+ 10 V, 0...20 mA
Modicon TM5 digital module	Modicon TM5 analog module	Modicon TM5 compact block	Modicon TM7 digital block	Modicon TM7 analog block
Please consult on our web site www.schneider-electric.com				

chapter 4

Communication



All technical information about products listed in this chapter are available on www.schneider-electric.com

■ **Modbus and Character mode serial link**

- **Modicon TM5 communication modules for Modbus serial link dedicated to Modicon M258 logic controller, compact base for Solutions with AFB**
 - Presentation 4/2
 - References 4/3

- **Cabling system for Modicon M238 & M258 logic controllers, compact bases for Solutions with AFB**
 - Connection 4/4
 - References 4/5

■ **Ethernet Modbus/TCP network**

- **Cabling system for Hardware platform controllers**
 - Connection 4/6
 - References 4/7

- **TwidoPort interface module for Modicon M238 logic controller, compact base for Solutions with AFB**
 - Presentation 4/8
 - References 4/9

Communication

Modicon TM5 communication modules for Modbus serial link

for Modicon M258 logic controller, compact base for Solutions with Application function Blocks (AFB)

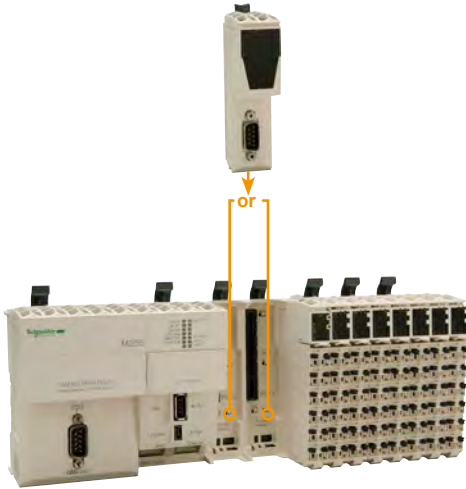

TM5 PCRS● communication module: for mounting the two free PCI slots in the M258 logic controller

Presentation

TM5 PCRS● communication modules are designed for TM258LF42DTS0, TM258LF42DT4LS0, TM258LF42DRS0, TM258LF66DT4LS0 logic controllers for Solutions with AFB, and are installed in one of the two free PCI slots in.

TM5 PC●●● communication modules can be used to configure one or two additional Modbus or ASCII serial links as RS232 or RS485.

Nota: the maximum number of communication modules is 2.

Modbus and Character mode serial links

Cabling system: see page 4/4.

Description

TM5 PCRS● communication modules comprise:

- 1 A locking clip for mounting/dismounting on the controller
- 2 A channel and module diagnostics LED display block
- 3 A connector for linking to the controller
- 4 A SUB-D connector (male 9-way) for connection to the serial link

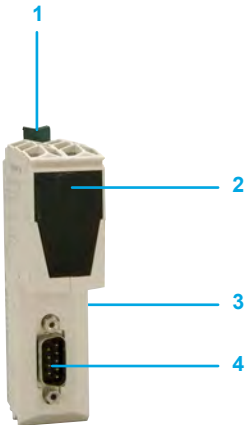

Serial link

LED	Colour	Status: on
Status	Green	Operation in progress
	Red	Controller starting
RXD	Yellow	Reception on interface: <input type="checkbox"/> RS232 with TM258PCRS2 <input type="checkbox"/> RS485 with TM258PCRS4
TXD	Yellow	Transmission on interface: <input type="checkbox"/> RS232 with TM258PCRS2 <input type="checkbox"/> RS485 with TM258PCRS4

Communication

Modicon TM5 communication modules for Modbus serial link

for Modicon M258 logic controller, compact base for Solutions with
Application function Blocks (AFB)



TM5 PCRS●

References					
Description	Used for	Physical layer/ protocols	Built-in port	Reference	Weight kg lb
Modbus serial link communication modules	Logic controllers type S: <input type="checkbox"/> TM258LF42DTS0 <input type="checkbox"/> TM258LF42DT4LS0 <input type="checkbox"/> TM258LF42DRS0 <input type="checkbox"/> TM258LF66DT4LS0	RS232/ Modbus/ASCII, SoMachine	SUB-D connector (male 9-way)	TM5PCRS2	0.064 0.141
		RS485 / Modbus/ASCII, SoMachine	SUB-D connector (male 9-way)	TM5PCRS4	0.064 0.141

MODBUS

Modbus cabling system

Non isolated link (Modicon M238/M258 master)

Isolated link (Modicon M238/M258 master)

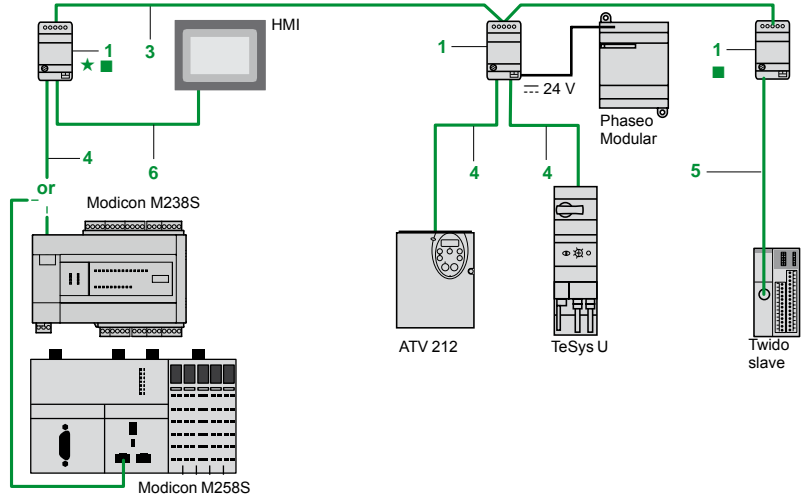
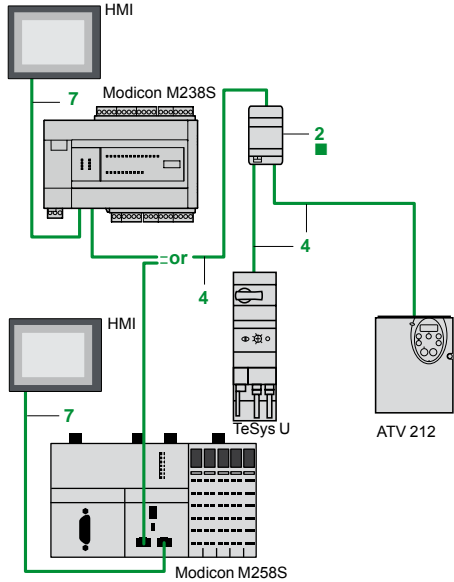

Length of cables between Modicon M238S/M258S and Altivar 212: ≤ 30 m max. (98.425 ft max.)

Total length of cables between isolation boxes 1: ≤ 1000 m (3280.840 ft)
Length of tap cables 4, 5 or 6: ≤ 10 m (32.808 ft)

- ★ Line polarization active
- Line termination

References

Tap-off and adapter components for RS 485 serial link

Description	Application	Item	Length	Reference	Weight kg lb
Tap isolation box Screw terminal block for main cable 2 x RJ45 for tap-off	- RS 485 line isolation (1) - Line end adapter (RC 120 Ω , 1nF) - Line pre-polarisation (2 R 620 Ω) - 24 V supply (screw terminal block) or 5 V (via RJ45) Mounting on 35 mm (1.378 in.)	1	-	TWDXCAISO	0.100 0.220
		Tap junction box 1 x RJ45 for main cable 2 x RJ45 for tap-off	2	-	TWDXCAT3RJ
Modbus hub Screw terminal block for main cable 10 x RJ45 for tap-off	Mounting on 35 mm (1.378 in.) on mounting plate or panel (2 x \varnothing 4 mm (2 x \varnothing 0.157 in.) screws)	-	-	LU9GC3	0.500 1.102
T-junction boxes 2 x RJ45 for main cable	1 integrated cable with RJ45 connector for Altivar variable speed controller dedicated tap-off	-	0.3 m 0.984 ft	VW3A8306TF03	-
		-	1 m 3.281 ft	VW3A8306TF10	-
Passive tap junction box	- Line extension and single-channel tap-off on screw terminal block - Line end adapter	-	-	TSXSCA50	0.520 1.146
RS 232C/RS 485 line converter	- Flow rate 19.2 Kbit/s max. - Without modem signals - 24 V/20 mA supply, Mounting on 35 mm (1.378 in.)	-	-	XGSZ24	0.100 0.220

(1) Line isolation recommended for distances > 10 m (32.808 ft)



TWD XCA ISO



TWD XCA T3RJ



LU9 GC3



TSX SCA 50



XGS Z24

References (continued)					
Connection cables for RS 485 serial link					
Description	Application	Item	Length	Unit reference	Weight kg lb
Main cables double shielded twisted pair RS 485	Modbus serial link, supplied without connector	3	100 m	TSXCSA100	5.680
			328.064 ft		12.522
			200 m	TSXCSA200	10.920
			656.168 ft		24.074
Modbus cordsets RS 485	2 x RJ45 connectors	4	0.3 m	VW3A8306R03	0.030
			0.984 ft		0.066
			1 m	VW3A8306R10	0.050
	1 x RJ45 connector and 1 end with free wires	-	3.281 ft		0.110
			3 m	VW3A8306R30	0.150
			9.843 ft		0.331
	1 mini-DIN connector for Twido controller and 1 RJ45 connector	-	1 m	TWDXCAFJ010	0.060
			3.281 ft		0.132
			3 m	VW3A8306D30	0.150
	1 mini-DIN connector for Twido controller and 1 RJ45 connector	-	9.843 ft		0.331
			0.3 m	TWDXCARJ003	0.040
			0.984 ft		0.088
	1 mini-DIN connector for Twido controller and 1 RJ45 connector (1) (2)	5	1 m	TWDXCARJ010	0.090
			3.281 ft		0.198
	1 mini-DIN connector for Twido controller and 1 RJ45 connector Dedicated programming protocol (2) (3)	-	3 m	TWDXCARJ030	0.160
			9.843 ft		0.353
1 mini-DIN connector for Twido controller and 1 RJ45 connector (1) (2)	5	0.3 m	TWDXCARJP03	0.027	
		0.984 ft		0.060	
1 mini-DIN connector for Twido controller and 1 RJ45 connector Dedicated programming protocol (2) (3)	-	0.3 m	TWDXCARJP03P	0.027	
		0.984 ft		0.060	
1 mini-DIN connector for Twido controller and 1 end with free wires	-	1 m	TWDXCAFD010	0.062	
		3.281 ft		0.137	
		10 m	TSXCX100	0.517	
Modicon M238 cordsets (SL1, SL2) to Magelis HMI terminal	2 x RJ45 connectors	7	32.806 ft		1.140
			2.5 m	XBTZ9980	0.150
			8.202 ft		0.331
1 x RJ45 connector and 1 x SUB-D 25-way connector	6, 7	2.5 m	XBTZ938	0.210	
		8.202 ft		0.463	
1 x RJ45 connector and 1 x SUB-D 9-way connector	7	2.5 m	XBTZ9008	0.150	
		8.202 ft		0.331	
Cordsets for Magelis STU	2 x RJ45 connectors	7	3 m	VW3A8306R30	0.150
			9.843 ft		0.331
Line end adapter	For RJ45 connector R = 120 Ω, C = 1 nf	-	Order in multiples of 2	VW3A8306RC	0.200
					0.441

Connection cables for RS 232 serial link					
Description	Application		Length	Reference	Weight kg lb
Cordset for DTE terminal (printer) (4)	Serial link for terminal device (DTE) 1 x RJ45 connector and 1 x 9-way SUB-D female connector		3 m	TCSMCN3M4F3C2	0.150
			9.843 ft		0.331
Cordset for DCE terminal (modem, converter)	Serial link for point to point device (DCE) 1 x RJ45 connector and 1 x 9-way SUB-D male connector		3 m	TCSMCN3M4M3S2	0.150
			9.843 ft		0.331

(1) Forcing the configuration of RS 485 integrated port with TwidoSuite programming protocol parameters.

(2) Carries 5 V voltage (supplied by RS 485 integrated port of Twido controller) for **TWD XCA ISO** tap isolation box (not using the 5 V external power supply).

(3) Allows the using of RS 485 integrated port with the parameters defined in configuration.

(4) If the terminal is equipped with a 25-way SUB-D connector, Please order a SUB-D 25-way female/9-way male adapter **TSX CTC 07** as well.

Ethernet

Ethernet Modbus/TCP or Ethernet IP network architecture

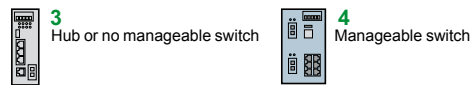
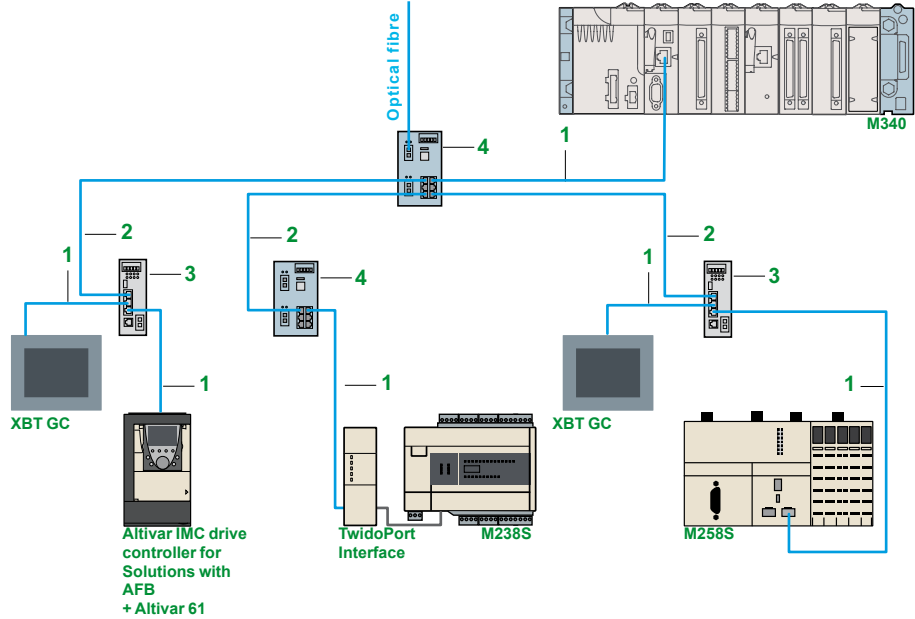

References (1)

Shielded copper connection cables

ConneXium shielded copper connection cables are available in two versions to comply with the different standards and approvals in force:

■ Shielded twisted pair copper cables to standard EIA/TIA 568

These cables conform to:

- standard EIA/TIA 568, category CAT 5E,
- standard IEC 11801/EN 50173, class D.

Their flame resistance conforms to:

- NFC 32070# classification C2
- standards IEC 322/1,
- Low Smoke Zero Halogen (LSZH).

■ Shielded twisted pair copper cables, UL and CSA 22.1 approved

These cables conform to:

- standards UL and CSA 22.1.
- Their flame resistance conforms to NFPA 70.

“Do It Yourself” cable and connectors

The ConneXium “Do It Yourself” range allows the user to make up Ethernet copper cables on site and to the required length. They are designed for cabling Ethernet 10/100 Mbit/s networks. The maximum length of cables made up in this way is 80 m. They can be assembled quickly using a knife and cutting pliers (no special tools are required).

Description	Characteristics	Length	Reference	Weight kg
Ethernet copper cable 24 AWG	Conforming to the above-mentioned standards and approvals	300 m 984.252 ft	TCSECN300R2	–
RJ 45 connector	Conforming to EIA/TIA-568-D	–	TCSEK3MDS	–
M12 connector	Conforming to IEC 60176-2-101	–	TCSEK1MDRS	–

(1) For other versions (optical fibre, switches,...), please consult our site www.schneider-electric.com



490 NT●000●●

References (continued)					
Shielded twisted pair cables to standard EIA/TIA568					
Description	Pre-formed at both ends	Item	Length	Reference	Weight
Straight cables	2 x RJ45 connectors	1	2 m (6.562 ft)	490NTW00002	—
	For connection to terminal equipment (DTE)		5 m (16.404 ft)	490NTW00005	—
			12 m (39.370 ft)	490NTW00012	—
			40 m (131.234 ft)	490NTW00040	—
			80 m (262.467 ft)	490NTW00080	—
Crossover cables	2 x RJ45 connectors	2	5 m (16.404 ft)	490NTC00005	—
	For connection between hubs, switches and transceivers		12 m (39.370 ft)	490NTC00015	—
			40 m (131.234 ft)	490NTC00040	—
			80 m (262.467 ft)	490NTC00080	—



TCS ESU 043F1N0

Shielded twisted pair cables, UL and CSA 22.1 approved					
Description	Pre-formed at both ends	Item	Length	Reference	Weight
Straight cables	2 x RJ45 connectors	1	2 m (6.562 ft)	490NTW00002U	—
	For connection to terminal equipment (DTE)		5 m (16.404 ft)	490NTW00005U	—
			12 m (39.370 ft)	490NTW00012U	—
			40 m (131.234 ft)	490NTW00040U	—
			80 m (262.467 ft)	490NTW00080U	—
Crossover cables	2 x RJ45 connectors	2	5 m (16.404 ft)	490NTC00005U	—
	For connection between hubs, switches and transceivers		40 m (131.234 ft)	490NTC00040U	—
			80 m (262.467 ft)	490NTC00080U	—



TCS ESM 043F2C●0

Shielded twisted pair cable for IP 67 switch					
Description	Pre-formed at both ends	Item	Length	Reference	Weight
Straight cables	1 x IP 67	—	1 m (3.281 ft)	TCSECL1M3M1S2	—
	4-way M12 connector and 1 x RJ45 connector		3 m (9.843 ft)	TCSECL1M3M3S2	—
			5 m (16.404 ft)	TCSECL1M3M5S2	—
			10 m (32.808 ft)	TCSECL1M3M10S2	—
			25 m (82.021 ft)	TCSECL1M3M25S2	—
			40 m (131.234 ft)	TCSECL1M3M40S2	—



499 NMS/NSS 251 02

ConneXium hub					
Description	Number of ports		Item	Reference	Weight
	Copper cable	Fibre optic			
Twisted pair hub 10BASE-T copper ports, RJ45 shielded connectors	4	—	3	499NEH10410	0.530 1.168



TCS ESM 083F2C●0

ConneXium switches						
Description	Number of ports		Item	Manag-eable	Reference	Weight
	Copper cable	Fibre optic				
Optimized twisted pair switch: 10BASE-T/100BASE-TX copper ports, RJ45 shielded connectors, 100BASE-FX optic port, SC connectors	3	—	3	No	TCSESU033FN0	0.113 0.249
	4	1	3	No	TCSESU043FN0	0.120 0.265
	5	—	3	No	TCSESU053FN0	0.113 0.249
Twisted pair switches: 10BASE-T/100BASE-TX copper ports, RJ45 shielded connectors	8	—	3	No	499NES18100	0.230 0.507
	8	—	4	Yes	TCSESM083F23F0	0.410 0.904
Twisted pair and fibre optic switches 10BASE-T/100BASE-TX copper ports, RJ45 shielded connectors, 100BASE-FX optic ports, SC connectors	3	1, multimode	4	Yes	TCSESM043F1CU0	0.400 0.882
	2	2, multimode	4	Yes	TCSESM043F2CU0	0.400 0.882
	3	1, single-mode	4	Yes	TCSESM043F1CS0	0.400 0.882
	2	2, single-mode	4	Yes	TCSESM043F2CS0	0.400 0.882
	4	1, multimode	3	No	499NMS25101	0.330 0.728
	3	2, multimode	3	No	499NMS25102	0.335 0.739
	4	1, single-mode	3	No	499NSS25101	0.330 0.728
	3	2, single-mode	3	No	499NSS25102	0.335 0.739
	7	1, multimode	4	Yes	TCSESM083F1CU0	0.410 0.904
	6	2, multimode	4	Yes	TCSESM083F2CU0	0.410 0.904



TCS ESU 051 F0

IP 67 twisted pair switch (1) 10BASE-T/100BASE-TX copper ports, shielded M12 connectors (type D)	5	—	—	No	TCSESU051F0	0.210 0.463
--	---	---	---	----	-------------	----------------

(1) Require special cables with M12 connectors for their --- 24 V supply: XZCP1●64L●.

Communication

Ethernet Modbus/TCP network for Modicon M238 logic controller

compact base for Solutions with Application function Blocks (AFB)

Presentation

TwidoPort module **499TWD01100** is an Ethernet interface that is easy to use and dedicated to Modicon M238 logic controllers for Solutions with AFB and Twido compact or modular programmable controllers. It allows incorporation of this controllers into an Ethernet network as a passive device (slave). The TwidoPort module is ready for use.

When connected to the integrated RS 485 serial port acts as a gateway between the Ethernet network and the controller's Modbus serial link port.

The main characteristics of the TwidoPort module are as follows:

- Connects to the RS 485 of the Modicon M238 controller for Solutions with AFB (marked SL1 or SL2 depending on model) or the RS 485 port of the Twido controller; no external auxiliary supply is necessary.
- Ethernet configuration:
 - takes the Ethernet configuration from the Twido application configuration (normal mode),
 - supports manual configuration using Telnet.
- Provides Ethernet statistics via a Telnet session.

Description

The TwidoPort **499TWD01100** interface module comprises:

- 1 Five pilot lights indicating the status of the interface and of the TwidoPort module links.
- 2 An RJ45 type connector for connection of the power supply and of the link to the controller's integrated RS 485 port. This connection is made using connection cable **TWDXCARJP03P** supplied with the TwidoPort interface module in case of the Twido controller.
- 3 An RJ45 connector (accessed through the bottom of the module) for connection to the Ethernet TCP/IP network.
- 4 An earthing screw (accessed through the bottom of the module).

The TwidoPort interface module can be mounted as standard on a symmetrical \sqcup rail.

Mounting kit **TWDXMT5** (sold in lots of 5) allows plate or panel mounting: 2 x \varnothing 4.3 mm (2 x \varnothing 0.169 in.) holes.

To order separately

For connecting to the Modicon M238 controller, the cordset for connection Modbus **XBTZ9980**, length 2.5 m (8.202 ft).

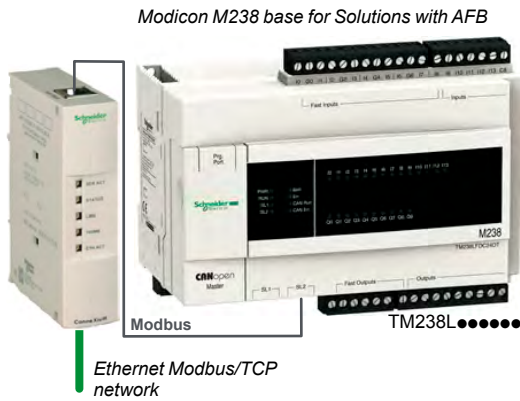

Ethernet Modbus/TCP network

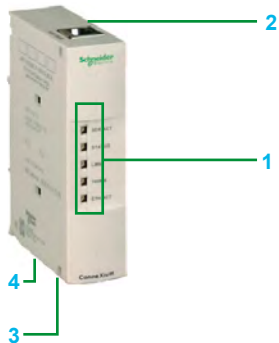

Communication

Ethernet Modbus/TCP network
for Modicon M238 logic controller

compact base for Solutions with Application function Blocks (AFB)



499 TWD 01100

References

Description	Controller bases	Function	Reference	Weight kg lb
TwidoPort interface module	Modicon M238 for Solutions with AFB 24 I/O	10/100 Mbit/s Auto MDIX function Connection cordset to Twido base controller TDXCARJP03P included, length 0.3 m (0.984 ft)	499TWD01100	0.200 0.441

Description	Use	Length	Reference	Weight kg lb
Modbus RS 485 cordsets	Connection to Modicon M238 for Solutions with AFB Equiped with 2 RJ45 connectors	2.5 m 8.202 ft	XBTZ9980	0.100 0.220

chapter 5

Associated offers



All technical information about products listed in this chapter
are available on www.schneider-electric.com

- **Altivar 212 and Altivar 61 variable speed drives**
 - Presentation 5/2
 - Selection guide 5/4

- **Altistart 01, Altistart 22 and Altistart 48 soft starters for asynchronous motors**
 - Selection guide 5/6

- **Protection components**
 - Selecting motor starting mode 5/8 to 5/10
 - TeSys Contactors 5/12
 - TeSys protection components: Thermal-magnetic motor circuit-breakers . . 5/13
 - Protection relays and controllers 5/14
 - Feeder protection and circuit disconnection 5/16
 - Branch circuit and control circuit protection 5/17
 - Power & Energy - Monitoring & Control 5/18

- **Enclosures**
 - Spacial enclosures 5/20
 - Thalassa enclosures 5/21

- **Control and signalling units**
 - Control and signalling units 5/22
 - Control stations and enclosures 5/24

- **Power supplies Phaseo**
 - Regulated switch mode power supplies: Selection guide 5/26

- **Magelis Operator dialogue terminals**
 - Magelis™ Small Panels 5/28
 - Magelis™ GT Advanced Panels 5/30
 - Magelis™ GK, GH and GTW Advanced Panels 5/32
 - Magelis™ GTO Optimum Advanced Panels 5/34
 - Magelis™ GTO Optimum Advanced Panels: Presentation 5/35
 - Magelis™ GTO Optimum Advanced Panels: Selection guide 5/36

- **OsiSense XM pressure sensors**
 - OsiSense XM pressure sensors for pumping application 5/38

- **Measurement & control relays - Zelio Control**
 - Modular and industrial relays 5/40 to 5/43

- **Product reference index**
 - index 5/44

Altivar 212 variable speed drives

Orientated towards performance, intelligence and building protection

The Altivar 212 is focused on Pumping machine as a dedicated variable speed drive for pumps and compressors.



Drives

- > from 0.75 up to 75 kW (from 1 to 100 hp)
- > from 200 to 480 V
- > 3 phases

Orientated towards performance, intelligence and pumping protection

- > Easy integration to building supervision network using embedded protocols
- > Instant detection of system failure: belt breakage, pump running dry, phase failure, etc.
- > Preventive maintenance for reducing costs: fault alert, operating time, etc
- > Energy consumption monitoring

Focused on user-friendliness

- > Easy set-up, commissioning and diagnostics tools: remote graphic terminal (6 languages as standard), Multi-Loader, PC Software, Bluetooth capability and SoMove Mobile software
- > Compact size for better integration

Focused on cost savings

- > Reduced investment costs (embedded functionalities)
- > Quick return on investment (energy saving)

Focused on protection & efficiency

- > Continuity of service
- > Functions designed for buildings: fire mode, damper monitoring, mechanical protection, etc.
- > Integrated EMC filter
- > Antiharmonic technology (THDI \approx 30%)

Selection guide: [see page 5/4](#)



Pumping application

Altivar 61 variable speed drives

Energy savings and performance for your pumps

The Altivar 61 is a variable speed drive with variable torque and is designed for exceptional versatility from the smallest application to the highest power rating.



Drives

- > from 0.37 up to 2400 kW (from 0.49 to 3217 hp)
- > from 200 to 690 V
- > 3 phases

Communication

- > Connectivity to all fieldbuses (integrated Modbus and CANopen)
- > Multi-language graphic display terminal

Flexibility

- > Option cards: programmable I/O

Powerful

- > Multi-pump management
- > Saves energy
- > Optimises automation solutions with its seamless integration into the architecture
- > Suitable for a wide range of power ratings (0.37 to 2400 kW - 0.49 to 3217 hp)
- > Integrated safety function

Rugged in harsh environments

- > 3C2 reinforced version, standard IEC 721-3-3 (gas, liquids), IP20/IP54
- > Versions with water cooling
- > IP54/IP55 wall-mounted or floor-standing enclosures available
- > Complies with ATEX safety standards (explosive environments)

Selection guide: see page 5/5



Multi-pump solution

Applications
Types of control

<ul style="list-style-type: none"> ■ Building pumps and fans ■ HVAC equipment
Variable speed drives for asynchronous motors



Standards and certifications

IEC/EN 61800-5-1, IEC/EN 61800-3 (environments 1 and 2, categories C1 to C3)
EN 55011: Group 1, Class A and Class B with option. CE, UL, CSA, C-Tick, NOM

Drive	Output frequency
Type of control	Asynchronous motor
	Synchronous motor
	Transient overtorque

0.5...200 Hz
Sensorless flux vector control
Voltage/frequency ratio (2 points)
Energy saving ratio
–
120% of nominal motor torque

Functions	Number of functions
------------------	---------------------

50

Number of preset speeds

7

Speed range

1...10

No. of I/O	Analog inputs
	Digital inputs
	Analog outputs
	Digital outputs
	Relay outputs

2
3
1
–
2
–

Reduction in harmonic currents

–

Communication	Integrated
	Available as an option

Modbus, METASYS N2, APOGEE FLN, BACnet
LONWORKS

Cards (optional)

–

Dialogue tools

IP 54 or IP 65 remote display terminal
--

Configuration tools

PCSoft setup software for ATV 212
Multi-Loader configuration tools

Supply voltage

Three-phase 200...240 V	Three-phase 380...480 V
--------------------------------	--------------------------------

Motor power for 50...60 Hz line supply

0.75...75 kW (1...10 hp)	0.75...75 kW (1...10 hp)
---------------------------------	---------------------------------

Motor power (kW-HP)	Line current (A)			
	200 V	240 V	380 V	480 V
0.37 - 0.5	6.9	5.8	–	–
0.75 - 1	12	9.9	–	–
1.5 - 2	18.2	15.7	–	–
2.2 - 3	25.9	22.1	–	–
3	25.9	22	–	–
4 - 5	34.9	29.9	–	–
5.5 - 7.5	47.3	40.1	–	–
0.75 - 1	3.3/6.1	2.7/5.3	1.7	1.4
1.5 - 2	6.1/11.3	5.1/9.6	3.2	2.5
2.2 - 3	8.7/15	7.3/12.8	4.6	3.6
3	–/19.3	10/16.4	6.2	4.9
4 - 5	14.6/25.8	13/22.9	8.1	6.4
5.5 - 7.5	20.8/35	17.3/30.8	10.9	8.6
7.5 - 10	27.9/45	23.3/39.4	14.7	11.7
11 - 15	42.1/53.3	34.4/45.8	21.1	16.8
15 - 20	56.1/71.7	45.5/61.6	28.5	22.8
18.5 - 25	67.3/77	55.8/69	34.8	27.8
22 - 30	80.4/88	66.4/80	41.6	33.1
30 - 40	113.3/124	89.5/110	56.7	44.7
37 - 50	–/141	–/127	68.9	54.4
45 - 60	–/167	–/147	83.8	65.9
55 - 75	–/200	–/173	102.7	89
75 - 100	–/271	–/232	141.8	111.3
90 - 125	336	288	–	–

References (without EMC filter)	References with integrated EMC filter, categories C1, C2 or C3
–	–
–	–
–	–
–	–
–	–
–	–
–	–
–	–
–	–
–	–
–	–
ATV 212H075M3X	ATV 212H075N4
ATV 212HU15M3X	ATV 212HU15N4
ATV 212HU22M3X	ATV 212HU22N4
ATV 212HU30M3X	ATV 212HU30N4
ATV 212HU40M3X	ATV 212HU40N4
ATV 212HU55M3X	ATV 212HU55N4
ATV 212HU75M3X	ATV 212HU75N4
ATV 212HD11M3X	ATV 212HD11N4
ATV 212HD15M3X	ATV 212HD15N4
ATV 212HD18M3X	ATV 212HD18N4
ATV 212HD22M3X	ATV 212HD22N4
ATV 212HD30M3X	ATV 212HD30N4
–	ATV 212HD37N4
–	ATV 212HD45N4
–	ATV 212HD55N4
–	ATV 212HD75N4
–	–

(1) Other voltages available (Three-phase 380...480 V or three-phase 500...690 V), please consult our "Altivar 61 variable speed drives" catalogue or our website www.schneider-electric.com

(2) For motors with a higher rating than 90 kW (120 hp), please consult our "Altivar 61 variable speed drives" catalogue or our website www.schneider-electric.com

- Industrial pumps and fans
- HVAC equipment
- Compressors

Variable speed drives for asynchronous motors



IEC/EN 61800-5-1, IEC/EN 61800-3 (environments 1 and 2, categories C1 to C3), IEC/EN 61000-4-2/4-3/4-4/4-5/4-6/4-11, CE, UL, CSA, DNV, C-Tick, NOM, GOST

0.1...500 Hz for the whole range
0.1...599 Hz up to 37 kW (up to 50 hp) in 200...240 V ~ and 380...480 V ~

Sensorless flux vector control
Voltage/frequency ratio (2 or 5 points)
Energy saving ratio

Vector control without speed feedback
120% of nominal motor torque for 60 seconds

> 100

8

1...100 in open loop mode

2...4

6...20

1...3

0...8

2...4

DC choke integrated or supplied with the drive

Modbus and CANopen

Modbus TCP Daisy Chain, Modbus/Uni-Telway, EtherNet/IP, DeviceNet, PROFIBUS DP V0 and V1, INTERBUS, CC-Link, LonWorks, METASYS N2, APOGEE FLN, BACnet

I/O expansion cards, Controller Inside programmable card, Altivar IMC integrated controller card, multi-pump cards, encoder interface cards (2)

IP 54 or IP 65 remote display terminal

SoMove setup software
Simple Loader and Multi-Loader configuration tools

Single-phase 200...240 V

Three-phase 200...240 V (1)

0.37...630 kW (0.50...845 hp) (2)

0.37...630 kW (0.50...845 hp) (2)

0.37...630 kW (0.50...845 hp) (2)

References with integrated EMC filter, categories C1, C2 or C3	References with integrated EMC filter (up to 7.5 W), category C2	References (without EMC filter)
ATV 61H075M3	-	-
ATV 61HU15M3	-	-
ATV 61HU22M3	-	-
ATV 61HU30M3	-	-
ATV 61HU40M3	-	-
ATV 61HU55M3	-	-
ATV 61HU75M3	-	-
-	ATV 61H075M3	-
-	ATV 61HU15M3	-
-	ATV 61HU22M3	-
-	ATV 61HU30M3	-
-	ATV 61HU40M3	-
-	ATV 61HU55M3	-
-	ATV 61HU75M3	-
-	-	ATV 61HD11M3X
-	-	ATV 61HD15M3X
-	-	ATV 61HD18M3X
-	-	ATV 61HD22M3X
-	-	ATV 61HD30M3X
-	-	ATV 61HD37M3X
-	-	ATV 61HD45M3X
-	-	ATV 61HD55M3X
-	-	ATV 61HD75M3X
-	-	ATV 61HD90M3X

Selecting motor starting mode

Selecting devices

The starter mode is closely linked to the load carried by the motor. The table below presents several typical applications in process control, part of which are used in processes such as water treatment or cement production. The examples illustrate how the selection is made.

Type of actuator	Description/ comment	Power range	Torque	Direct On Line (D.O.L.)	Soft starter	Speed Drive
Centrifugal Pump	<ul style="list-style-type: none"> > Centrifugal pumps are used to cover a wide range of volume and pressure conditions > The flow can be controlled by using valves on the pump discharge manifold or by changing the rotation speed 	1 kW to 10 Kw	Quadratic	■	■	■
		10kW to > 1MW	Quadratic		■	■
Dosing pump	<ul style="list-style-type: none"> > Dosing pumps are frequently used to inject fluids that may be difficult to mix efficiently in batch-tank systems because of their low volume 	< 10 kW	Constant	■		■
Screw pump	<ul style="list-style-type: none"> > Screw pumps are also known as Archimedes' screw > They are used for lifting large volumes of fluid or material to a limited height > They are driven through a speed reduction gear 	1 to 50 kW	Constant	■	■	
Mixer	<ul style="list-style-type: none"> > Mixers are used to give homogeneity to fluids > Agitation is also used to speed up chemical process > Mixing is performed by a propeller rotating in the fluid driven by a speed reduction gear 	1 to 50 kW	Constant		■	■
Moving devices	<ul style="list-style-type: none"> > Moving devices drive various types of mechanical systems such as: rotators, scrapers, shields, compressors, conveyors 	1 to 10kW	Constant	■		■
Air blower and fan	<ul style="list-style-type: none"> > Air blowers or fans are used to provide air or oxygen for ventilation or aeration tank > Flow can be adjusted using a mechanical system (fixed speed) or variable speed drive. Energy savings are possible by operating at reduced speed 	10 kW to 1 MW	Quadratic or constant		■	■
Mill and crusher	<ul style="list-style-type: none"> > Mills and crushers are used to grind materials > They are typically high torque 	50 kW to 2 MW	Variable		■	■

5

Selecting motor starting mode

Control starter functions

Depending on needs, it is necessary to control some or all functions of a starter.

The principal function groups are:

Motor control performance

> Control on power, torque, speed, reversing, start time, and risk of jamming are required.. Next table summarizes the main characteristics of pumps found in process applications.

Motor protection

> Its purpose is to avoid operating motors in abnormal conditions which could result in negative events such as:

- > overheating
- > premature ageing
- > destruction of electrical windings
- > damage to coupling or gearbox
- > etc.

Motor metering and monitoring functions

> The purpose of implementing measurement devices is to ensure continuous supervision of motor operating conditions. The collected data can be used with great benefit on improving energy efficiency and extending motor lifetime

> Monitoring functions allow you to control costs, schedule maintenance operations and keep historical information for legal requirements

The table on the next page presents a synthesis of different device functions.

Selecting motor starting mode

D.O.L. starter

Motor circuit breaker + Contactor LC•D or F	Starter controller TeSys U		
	Standard control unit	Advanced control unit	Multifunction control unit
			

Motor protection functions

> Short circuit	■	■	■	■
> Overload	■	■	■	■
> Locked rotor	■	■	■	■
> No load running			■	■
> Earth fault			■	■
> Supply phases failure and imbalance	■	■	■	■
> Ventilation fault				
> Abnormal temperature rise				
> Shaft bearing seizure				
> Insulation fault				
> Long starting time	■	■	■	■
> Current phase reversal				
> Load fluctuations (I, U, P)				
> Overtorque				

Metering functions

> Indication of motor load			■	■
> Current on 3 phases (rms value)				■
> Average current				■
> Thermal capacity level				
> Motor temperature				
> Voltages on 3 phases				
> Frequency				
> Active power, power factor				
> Earth current				
> Motor torque				

Monitoring functions

> Fault differentiation			■	■
> Remote or automatic thermal reset			■	■
> Local control, with I/O on product				■
> Local control, with HMI terminal				■
> Acceleration, decelerating torque control				
> Linear, S, U or customized acceleration and deceleration ramps				
> Bypass by contactor at starting end				
> Brake sequence				
> Automatic catching a spinning load, speed detection and automatic restart				
> Energy saving ratio, 2-point or 5-point quadratic ratio				
> Preset speed				
> Adaptation of current limiting according to speed				
> Noise and resonance suppression by switching frequency				
> Electricity and service hours meter				
> Detection of absence of fluid, detection of zero flow rate, limiting flow rate				
> Sleep function, wake-up function				
> Customer settings with display of physical values: bar, l/s, °C, etc.				
> Safety function, integrated "power removal" SIL2				
> PI regulator and reference				
> Fault statistics: counters and history per type of protection				■
> Motor statistics: storage of motor statistics values				
> Diagnosis of faults affecting correct operation of the product				■
> Download and save configuration				

5

Selecting motor starting mode



Motor protection functions	by upstream CB			
> Short circuit	■	■	■	■
> Overload	■	■	■	■
> Locked rotor	■	■	■	■
> No load running	■	■	■	■
> Earth fault	■	■	■	■
> Supply phases failure and imbalance	■	■	■	■
> Ventilation fault	■	■	■	■
> Abnormal temperature rise	■	■	■	■
> Shaft bearing seizure	■	■	■	■
> Insulation fault	■	■	■	■
> Long starting time	■	■	■	■
> Current phase reversal	■	■	■	■
> Load fluctuations (I, U, P)	■	■	■	■
> Overtorque	■	■	■	■
Metering functions				
> Indication of motor load	■	■	■	■
> Current on 3 phases (rms value)	■	■	■	■
> Average current	■	■	■	■
> Thermal capacity level	■	■	■	■
> Motor temperature	■	■	■	■
> Voltages on 3 phases	■	■	■	■
> Frequency	■	■	■	■
> Active power, power factor	■	■	■	■
> Earth current	■	■	■	■
> Motor torque	■	■	■	■
Monitoring functions				
> Fault differentiation	■	■	■	■
> Remote or automatic thermal reset	■	■	■	■
> Local control, with I/O on product	■	■	■	■
> Local control, with HMI terminal	■	■	■	■
> Acceleration, decelerating torque control	■	■	■	■
> Linear, S, U or customized acceleration and deceleration ramps	■	■	■	■
> Bypass by contactor at starting end	■	■	■	■
> Brake sequence	■	■	■	■
> Automatic catching a spinning load, speed detection and automatic restart	■	■	■	■
> Energy saving ratio, 2-point or 5-point quadratic ratio	■	■	■	■
> Preset speed	■	■	■	■
> Adaptation of current limiting according to speed	■	■	■	■
> Noise and resonance suppression by switching frequency	■	■	■	■
> Electricity and service hours meter	■	■	■	■
> Detection of absence of fluid, detection of zero flow rate, limiting flow rate	■	■	■	■
> Sleep function, wake-up function	■	■	■	■
> Customer settings with display of physical values: bar, l/s, °C, etc.	■	■	■	■
> Safety function, integrated "power removal" SIL2	■	■	■	■
> PI regulator and reference	■	■	■	■
> Fault statistics: counters and history per type of protection	■	■	■	■
> Motor statistics: storage of motor statistics values	■	■	■	■
> Diagnosis of faults affecting correct operation of the product	■	■	■	■
> Download and save configuration	■	■	■	■

■ With external probes

Applications

Equipment based on standard contactors

Equipment requiring low consumption contactors which can be switched directly from solid state outputs

Protection according to IEC60947-2 and UL508



Rated operational current

AC-3	6 A	6..0.16 A	9...150 A	115...800 A	750...1800 A	6...12 A	9...25 A
AC-1	12 A	20 A	25...200 A	200...2100 A	800...2750 A	20 A	20...40 A

Rated operational voltage

690 V	690 V	690 V	1000 V	1000 V	690 V	690 V
-------	-------	-------	--------	--------	-------	-------

Number of poles

2 or 3	3 or 4	3 or 4	2, 3 or 4	1...4	3 or 4	3
--------	--------	--------	-----------	-------	--------	---

Contactor type references

LC1 SK LP1 SK	LC1 K LC7 K LP1 K	LC1 D	LC1 F	LC1 B	LP4 K	LC1 D
------------------	-------------------------	-------	-------	-------	-------	-------

More information

Details and technical datasheets available on www.schneider-electric.com

5

<p>Applications</p>	<p>Protection of motors against short-circuits and overloads</p>				
<p>Protection according to IEC60947-2 and UL508</p>					
<p>Tripping threshold on short-circuit</p>	<p>13 I_n</p>				
<p>Standard motor power ratings in AC-3, 415 V</p>	<p>Up to 15 kW (up to 20 hp)</p>	<p>Up to 30 kW (up to 40 hp)</p>	<p>37 kW (up to 50 hp)</p>	<p>7.5...110 kW (10...147 hp)</p>	
<p>Operational current at 415 V</p>	<p>0.1...32 A</p>	<p>9...65 A</p>	<p>56...80 A</p>	<p>12...220 A</p>	
<p>Breaking capacity at 415 V (I_{cu}) to IEC 60947-2</p>	<p>10...100 kA</p>	<p>35...100 kA</p>	<p>50...100 kA</p>	<p>15 kA</p>	<p>35 and 36 kA</p>
<p>Door interlock mechanism</p>	<p>Without</p>	<p>With</p>	<p>With</p>	<p>Without</p>	<p>With</p>
<p>Circuit-breaker type</p>	<p>GV2 ME</p>	<p>GV2 P</p>	<p>GV3 P</p>	<p>GV3 ME80</p>	<p>GV7 RE</p>
<p>More information</p>	<p>Details and technical datasheets available on www.schneider-electric.com</p>				

Applications

Protection according to IEC60947-2 and UL508

Motor protection

Thermal motor protection



Protection

- Motor overload
- Stalling
- Phase failure

Tripping class

Class 10 A	Classes 10 A and 20	Classes 10 and 20
------------	---------------------	-------------------

Communication

–

Used with contactor type

LC1 K, LP1 K	LC1 D	LC1 F
--------------	-------	-------

Motor current (In)

0.11...16 A	0.1...150 A	30...630 A
-------------	-------------	------------





Relay or controller type

LR2 K	LRD, LR2 D and LR9 D	LR9 F
--------------	-----------------------------	--------------

More information

Details and technical datasheets available on www.schneider-electric.com

5

Machine protection		Motor and machine protection		
Protection of resistors, bearings, capacitors 	Specific motor protection  		Protection and control  	
<ul style="list-style-type: none"> - Frequent starting - Harsh environments 	<ul style="list-style-type: none"> - Overtorque - Mechanical shocks - Locked rotor - Phase failure 	<ul style="list-style-type: none"> - Overtorque - Mechanical shocks 	<ul style="list-style-type: none"> - Thermal overload - Phase imbalance and phase failure - Motor stalling - Long starting times - Earth fault 	<ul style="list-style-type: none"> - Thermal overload - Phase imbalance and phase failure - Locked rotor - Long starting times - Phase reversal - Earth fault
-			Classes 5 to 30	Classes 5 to 30
-			Modbus, CANopen, DeviceNet, Profibus DP, Advantys STB, AS-Interface	Modbus, CANopen, DeviceNet, Profibus DP, Ethernet TCP/IP
All contactors				
Unlimited	0.3...38 A	0.3...60 A	0.35...800 A	0.4...810 A
LT3 S	LR97D	LT47	LUTM ●0BL	LTM R

5

Details and technical datasheets available on www.schneider-electric.com

Feeder protection and circuit disconnection

Protection according to IEC60947-2 and UL489

PowerPact multistandard molded case circuit breakers

Proven performance

> Industry-leading circuit breaker innovation and protection for heavy-duty commercial and industrial applications

Flexible

> Full range of molded case circuit breakers from 15 A to 3,000 A deliver the ratings, configurations, and operations for your unique application

Simple

> Common catalogue numbers, standardized ratings, and a full-range of field-installable accessories make product selection, installation, and maintenance easier than ever

Direct access to energy efficiency

> Micrologic™ electronic trip units enable power and energy management

Powerpact



	HD	HG	HJ	JD	JG	JJ	LD	LG	LJ
Number of poles	3	3	3	3	3	3	3	3	3
Current range	15-150	15-150	15-250	60-250	60-250	60-250	250-600	250-600	250-600

Interrupting ratings

UL/CSA/NOM rating (kA RMS) (50/60 Hz AC)	240 VAC	65	100	25	65	100	25	65	100
480Y/277 VAC	–	–	–	–	–	–	–	–	–
480 VAC	18	35	65	18	35	65	18	35	65
600 Y/347 VAC	–	–	–	–	–	–	–	–	–
600 VAC	14	18	25	14	18	25	14	18	25
DC ratings	250 VDC	20	20	20	20	20	–	–	–
	500 VDC	–	–	–	20	–	–	–	–
IEC 60947-2 kA RMS (50/60 Hz AC) Icu/Ics	220/240 VAC	25/25	65/65	100/100	25/25	65/65	100/100	25/25	65/65
	380/415 VAC	18/18	35/35	65/65	18/18	35/35	65/65	18/18	35/35

Accessories

Shunt Trip	■	■	■	■	■	■	■	■	■
Undervoltage Trip	■	■	■	■	■	■	■	■	■
Auxiliary Switches	■	■	■	■	■	■	■	■	■
Handle Operators	■	■	■	■	■	■	■	■	■
Mechanical Interlocks	■	■	■	■	■	■	■	■	■
Handle Padlock Attachment	■	■	■	■	■	■	■	■	■

Trip system type

Thermal magnetic	■	■	■	■	■	■	–	–	–
Electronic	■	■	■	■	■	■	■	■	■

Enclosure

Dimensions (3-pole unit mount)	Height mm (in.)	163 (6.4)	191 (7.5)	340 (13.38)
	Width mm (in.)	104 (4.1)	104 (4.1)	140 (5.51)
	Depth mm (in.)	111 (4.4)	127 (5.0)	168 (6.61)

TeSys Vario load break switch according to IEC947-3 / UL508



> This switch is marked "Suitable as Motor Disconnect" allowing installation on the load side of the motor branch circuit, short-circuit, and ground-fault protection

> TeSys Vario rotary switch disconnectors from 10 to 115 A UL (12 to 175 A IEC) are suitable for the on-load making and breaking of resistive or mixed resistive and inductive circuits where frequent operation is required

Branch circuit and control circuit protection

Protection according to IEC60947-2, UL489 and UL1077



Multi 9™ miniature circuit breakers

- > In addition to the PowerPact molded case circuit breakers offer, IEC 947-2/ UL 489 miniature circuit breakers and UL 248 fuses should be used to protect loads like power transformers, the power supply, appliances, and heating and lighting
- > Multi 9™ C60 miniature circuit breakers are the first extensive range of DIN rail-mounted miniature circuit breakers to be UL 489 listed for branch circuit protection
- > Other Multi 9 devices are UL recognized as supplementary protectors suitable for applications where branch circuit protection is already provided or not required. Multi 9 C60 products also have IEC ratings. Other IEC-rated products complement the UL line up to 125 A at up to 440 VAC

Breaker type

	UL489 C60 (120/240 V)			UL489 C60 (480Y/277 Vac)			UL 1077 C60N			UL 1077 C60H-DC		
	1	2	3	1	2	3	1	2	3.4	1	2	
Number of poles	1	2	3	1	2	3	1	2	3.4	1	2	
Current range	0.5-35	0.5-35	0.5-35	0.5-20	1-20	0.5-20	0.5-63	0.5-63	0.5-63	0.5-40	0.5-40	
Interrupting ratings												
UL/CSA rating (kA RMS) (50/60 Hz AC)	120 VAC	10	–	–	10	–	–	10	–	–	–	–
	240 VAC	10	10	10	10	10	10	10	10	–	–	–
	277 VAC	–	–	–	10	10	10	5	–	–	–	–
	480Y/277 VAC	–	–	–	–	10	10	–	5	5	–	–
DC ratings	48 VDC	–	–	–	–	–	–	–	–	–	5	5
	60 VDC	10	10	–	–	–	–	–	–	5	5	
	65 VDC	–	–	–	–	–	10	–	–	5	5	
	125 VDC	–	10	–	–	–	–	10	–	5	5	
	250 VDC	–	–	–	–	–	–	–	–	5	5	
500 VDC	–	–	–	–	–	–	–	–	–	–	5	
IEC 60947-2 (50/60 Hz AC)	240 V	10	20	20	10	10	10	10	20	20	15	30
	415 V	10	10	10	10	10	10	3	10	10	4	15
	440 V	–	6	6	–	6	6	–	6	6	–	10
Accessories												
Shunt Trip	■	■	■	■	■	■	■	■	■	■	■	■
Undervoltage Trip	■	■	■	■	■	■	■	■	■	■	■	■
Auxiliary Switches	■	■	■	■	■	■	■	■	■	■	■	■
Handle Operators	■	■	■	■	■	■	■	■	■	■	■	■
Handle Padlock Attachment	■	■	■	■	■	■	■	■	■	■	■	■
GF Protection (GFP)	■	■	■	■	■	■	■	■	■	■	■	■
Enclosure												
Dimensions (3-pole unit mount)	Height mm (in.)	107 (4.21) (box lug)			141 (5.55)			81.02 (3.19)			81 (3.19)	
	Width mm (in.)	54 (2.13)			54 (2.13)			54 (2.13)			18 (.71) 36 (1.42)	
	Depth mm (in.)	76 (3.00)			76 (3.00)			76 (3.00)			65 (2.56)	

TeSys DF fuse holders according to IEC947- 3 / UL248

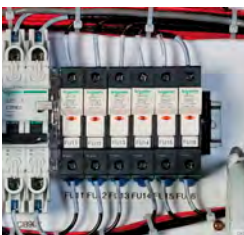

	UL512	
TeSys DF10	IEC UL (UL recognized)	> These devices are rated 690 Volts AC, maximum: > 32 amperes > 200 kA current withstand
TeSys DFCC	IEC UL (UL listed)	> These devices are rated 600 Volts AC, maximum: > 30 amperes > 200 kA current withstand
TeSys DF14	IEC UL (UL recognized)	> These devices are rated 690 Volts AC, maximum: > 50 amperes > 200 kA current withstand
TeSys DF22	IEC UL (UL recognized)	> These devices are rated 690 Volts AC, maximum: > 125 amperes > 200 kA current withstand

	Basic Monitoring	Advanced Monitoring
--	------------------	---------------------

Power Logic System



Name	AMP / VLT	DM6000 / DM6200
Function	Ammeter, Voltmeter	Digital panel Meter
Panel instrumentation	I / U	I, V, F, PF

Integrated in Compact NSX circuit breaker



Name	Micrologic A trip unit	
Function	Ammeter, Voltmeter	
Panel instrumentation	I / U	



- Reading easiness
- Essential parameters
- Single-phase
- “all-in-one” informations
- U and I (three-phase)
- Panel Front

Common accessories



Name	CT	CMA / CMV
Function	Current Transformers	Ammeter & Voltmeter selector

Power & Energy Monitoring

Energy Management & Control

Monitoring software



PM9 / PM700

PM1000 / PM1200

IEM3110

PM750 / PM820

PM3210

PowerView

Power Meter

Power Meter

Power Monitoring

I, U, F, P, Q, S, PF, E

I, U, F, P, Q, S, PF, E, THD, (Min/Max, I/O, alarm) and remote monitoring

- Real time viewing of data
- Historical tabular data into Microsoft Excel
- Historical trending
- Reporting



Micrologic E trip unit

Power Meter

I, U, F, P, Q, S, PF, E

- U and I (three-phase)
- Energy values
- Back-up

- U and I (three-phase)
- Energy values
- Communication with supervision systems
- Remote Monitoring (control, loading/unloading, alarms and alerts)

- Remote Monitoring**
- Remote monitoring software

Steel enclosures

Wall-mounting



- S3D Wall-mounting enclosures
- S3DEX Potentially explosive atmospheres
- S3DM Distribution modular enclosures

Description

Most common pumping architectures can be protected by Wall Mounting enclosures Spacial S3D, especially in indoor applications.

Dimensions

From 300 x 200 mm to 1400 x 1000 mm

Ingress protection rating

Up to IP66

Mechanical protection rating

Up to IK10

Options

Large choice of enclosure versions and accessories.

Why should I choose it?

Durable, with high UV resistance, coated hinges, aluminium hinge pins and folded gutters that avoids the entry of water, oil and other liquids.

Floor-standing

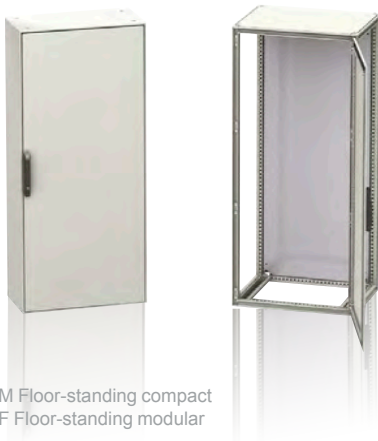

- SM Floor-standing compact
- SF Floor-standing modular

Description

For more equipment and heavy loads, pumping solutions can be installed in robust sheet metal compact enclosures (Spacial SM) or modular enclosures (Spacial SF). Up to 600 different possible configurations. Spacial SF is also available in kit version.

Dimensions

From 500 x 500 mm to 2200 x 1800 mm

Ingress protection rating

IP55

Mechanical protection rating

Up to IK10

Options

Large choice of enclosure versions and accessories.

Why should I choose it?

High level of modularity and flexibility. Save up 25 % of time in assembly.

ClimaSys

Thermal management



CV-CA Ventilation/Airing



CE Exchangers



CU Cooling Units

Accessories



Mounting



Power distribution



Cable management

Project & Services



Configured offer
Adapted services: cut-outs, painting, assemblies...



Specific offer
The co-development service tailor-made for you

Details and technical datasheets available on
www.schneider-electric.com

Insulating material enclosures

Description

Wall-mounting Thalassa insulating enclosures are made of Polyester which avoids any electrical contact risks. They resist to harsh conditions and outdoor environments (corrosion-free).

Dimensions

From 430 x 330 mm to 1050 x 850 mm

Ingress protection rating

Up to IP66

Mechanical protection rating

Up to IK10

Options:

Plinths, cable entries, mounting accessories and thermal management devices, as for other enclosures.



- PLM Wall-mounting polyester
- PLMEX Potentially explosive atmospheres

Why should I choose it?

Thalassa PLM are suitable for indoor or outdoor use and ensure a long-life lasting without maintenance.

Offline software



Spatial.pro
Graphic configurator



Digital Rules
Enclosures selector



Spatial.conf
Services configurator

Description

Thalassa PLA are floor-standing enclosures with a large choice of dimensions and combinations, for pumping solution in harsh environments where corrosion has to be taken in account.

Dimensions

From 500 x 500 mm to 1500 x 1250 mm

Ingress protection rating

Up to IP65

Mechanical protection rating

Up to IK10

Options

A variety of versions (completely sealed, open bottom, with or without canopy), mounting accessories and thermal management devices.



- PLA Floor-standing polyester enclosures
- PLD Floor-standing DIN polyester enclosures

Why should I choose it?

Thalassa PLA protect large and heavy control equipment in harsh and corrosive environments for indoors and outdoors.



CR Resistance Heaters



CC Thermal Control



ProClima
Thermal calculation software



Lighting & sockets



Door accessories



Earthing

Spare Parts

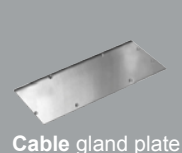

Cable gland plate



Doors









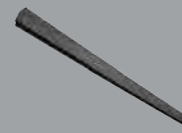









Door accessories



Fixing hardware



Roof accessories

Applications		Pilot lights	Pushbuttons, selector switches and pilot lights			Biometric switches
						
						
						
						
Description of range		<ul style="list-style-type: none"> ■ LED pilot lights 	<ul style="list-style-type: none"> ■ Pushbuttons ■ Multiple-headed pushbuttons ■ Emergency Stop buttons ■ Emergency switching off pushbuttons ■ Selector switches and key switches ■ Illuminated pushbuttons ■ Pilot lights 			<ul style="list-style-type: none"> ■ Fingerprint readers ■ Biometric switches 24V ...
Features	Products	Monolithic, compact, low consumption	Complete units or sub-assemblies (body + head)			Monolithic
	Bezel	Double insulated		Metal, chromium plated or black	Double insulated	Double insulated, dark grey
	Shape of head	Circular	Circular, square or rectangular	Circular	Circular or square	–
Drilling or cut-out for mounting		Ø 8 mm (Ø 0.315 in.) and Ø 12 mm (Ø 0.472 in.)	Ø 16 (Ø 0.630 in.)	Ø 22 mm (Ø 0.866 in.)		
Degree of protection	Conforming to IEC 60529	IP 40 IP 65 with seal	IP 65	IP 66		IP 65
Cabling		Tags for 2.8 x 0.5 mm (0.110 x 0.020 in.) connectors, or threaded connector	Faston connectors Solder pins for printed circuit boards	Spring clamp terminal connections Screw clamp terminal connections Faston connectors Connector With adaptor for printed circuit board		Cable or connectors
Mounting	Panel thickness	1...8 mm (0.039... 0.315 in.)	1...6 mm (0.039... 0.236 in.)			
Type references		XVLA	XB6	XB4	XB5	XB5S

Pages Please consult our web site www.schneider-electric.com

(1) Wireless and batteryless pushbutton and receiver ready-paired at the factory.



More technical information on www.schneider-electric.com

Wireless and batteryless pushbuttons	Pushbuttons, selector switches and pilot lights	Joystick controllers	Pushbuttons, selector switches and pilot lights	Cam switches		
						
Wireless and batteryless and pushbuttons 24 V $\overline{\text{---}}$ or 24... 240 V $\sim / \overline{\text{---}}$	<ul style="list-style-type: none"> ■ Pushbuttons ■ Emergency switching off pushbuttons ■ Selector switches and key switches ■ Illuminated pushbuttons ■ Pilot lights 	<ul style="list-style-type: none"> ■ 2 or 4 direction ■ Stay put or spring return 	<ul style="list-style-type: none"> ■ Pushbuttons ■ Emergency Stop buttons ■ Emergency switching off pushbuttons ■ Selector switches and key switches ■ Illuminated pushbuttons ■ Pilot lights 	<ul style="list-style-type: none"> ■ Switches ■ Stepping switches ■ Reversing and changeover switches ■ Ammeter switches ■ Voltmeter switches ■ Reversing switches ■ Star-delta and reversing star-delta switches ■ Pole change switches 		
Ready-to-use packs (1) and "components" range	Monolithic	Complete units or sub-assemblies (body + head with lever)	Complete units or sub-assemblies (body + head)	Complete units or sub-assemblies (body + front panel + head)		
Metal, chromium plated or double insulated, black	Double insulated, black	Metal, chromium plated	Double insulated, black	Metal, chromium plated or double insulated, black		
Transmitter with circular head	Circular	Circular	Hexagonal	Square		
\varnothing 22 mm (\varnothing 0.866 in.)			\varnothing 30 mm (\varnothing 1.181 in.)	\varnothing 16 mm (\varnothing 0.630 in.) or \varnothing 22 mm (\varnothing 0.866 in.) : series K10 \varnothing 22 mm (\varnothing 0.866 in.) and multifixing: series K1/K2 4 holes, 48 or 68 centres: series K30...K150		
IP 65	IP 65 (pushbuttons, pilot lights, selector switches) IP 54 (Emergency switching off pushbuttons)	IP 65	IP 66	IP 65	IP 65	IP 65: series K10 IP 40, IP 65 with seal: series K1/K2 IP 40: series K30...K150
Wireless (transmitter) Through cable (receiver)	Screw and captive clamp terminal connections Forked U type tag connections Faston clip connections (pilot lights)	Screw and captive clamp terminal connections				
1...6 mm (0.039... 0.236 in.)					0.5...6 mm 1...6 mm (0.020... 0.236 in.) Depending on model	
XB5R, XB4R	XB7	XD4PA	XD2GA	XD5PA	9001K,9001SK	K10, K1, K2, K30, K50, K63, K115, K150

Please consult our web site www.schneider-electric.com

Type of applications	All applications		
Enclosures	Plastic		Glass-reinforced polyester
	Complete stations and separate components for customer assembly		Empty insulated enclosures
Main feature	Pre-drilled control stations		Pre-drilled or undrilled enclosures
Associated control and signalling units	Harmony XB5 with plastic bezel		Harmony XB7, monolithic, plastic Harmony XB4 with metal bezel Harmony XB5 with plastic bezel
Number of cut-outs for Ø 22 mm (Ø 0.866 in.) control and signalling units	1, 2, 3, 4 or 5	1, 2 or 3 (complete stations) 1, 2, 3, 4 or 5 (empty enclosures)	1, 2 or 3 1, 2, 4, 8 or 16
Material	Polycarbonate		ABS Glass-reinforced polyester
Colour	Yellow lid Light grey base	Dark grey lid Light grey base	Light grey or yellow lid Light grey base Coloured grey throughout
Degree of protection	IP 66		IP 54 IP 65
Function	Emergency Stop push button	Start or Stop Start-Stop with pilot light Movement control	According to equipment fitted: <input type="checkbox"/> Start or Stop <input type="checkbox"/> Start-Stop with pilot light <input type="checkbox"/> Movement control <input type="checkbox"/> Emergency stop push button
Cable entries	Knock-outs		Tapped for cable gland
Type references	XAL K	XAL D	XAL E XAP A
Page(s)	Please consult our web site www.schneider-electric.com		

5



More technical information on www.schneider-electric.com

					Specific applications
--	--	--	--	--	-----------------------

Metal	Metal front plate, insulated protective rear cover	Plastic		Metal
Empty enclosures	Empty, flush mounting enclosures: front plate + rear cover	Control stations for severe environments	Lift inspection stations	Key operated control stations



Pre-drilled enclosures	Pre-drilled or undrilled enclosures	Pre-drilled front plates & rear covers	Pre-drilled empty control stations	Pre-drilled empty enclosures or fitted stations	Fitted stations
Harmony XB4 with metal bezel Harmony XB5 with plastic bezel			Harmony XB5 with plastic bezel	Harmony XB5 or XB7 with plastic bezel	With key lock
8, 16, 24, 30 or 40	1, 2, 3, 4, 6, 8 or 12	1, 2, 3, 4 or 5	1, 2, 3, 4 or 5	1, 2, 3, 4, 5 or 6 with or without power socket	–
Aluminium alloy or sheet steel	Zinc or aluminium alloy	Front plate: brushed aluminium Rear cover: polystyrene	Mineral reinforced polyamide	Polycarbonate	Zinc alloy
Blue lid and base	XAP M: Blue lid Blue base XAP J: Yellow lid Blue base	Unpainted aluminium	Black lid Black base	Yellow lid Light grey base	Grey
IP 54	IP 65		IP 66 IP 69K	IP 44, IP 55 or IP 66 depending on model	IP 54
According to equipment fitted: <input type="checkbox"/> Start or Stop <input type="checkbox"/> Start-Stop with pilot light <input type="checkbox"/> Movement control <input type="checkbox"/> Emergency stop push button					Start-Stop
Drilled		Knock-outs	ISO 20	Knock-outs	Tapped for cable gland
XB2 SL	XAP M, XAP J	XAP E	XAL G	XAL F	XAP S

Please consult our web site www.schneider-electric.com

Power supplies

Regulated switch mode power supplies
ABL 8MEM, ABL 7RM: 7 to 60 W - Rail mounting
ABL 8REM, ABL 7RP: 60 to 144 W - Rail mounting



Nominal input voltage	
Connection to worldwide line supplies	United States - 120 V (phase-to-neutral) - 240 V (phase-to-phase)
	Europe - 230 V (phase-to-neutral) - 400 V (phase-to-phase)
	United States - 277 V (phase-to-neutral) - 480 V (phase-to-phase)

~ 100...240 V --- 120...250 V
Single-phase (N-L1) connection or 2-phase (L1-L2) connection
Single-phase (N-L1) connection
-

Undervoltage control	
Protection against overloads and short-circuits	
Diagnostics relay	
Compatibility with function modules	
Power reserve (Boost)	

Yes	
Yes, voltage detection. Automatic reset on elimination of the fault	
-	
-	
1.25 to 1.4 I _n for 1 minute, depending on model (for ABL 8MEM)	No

Output voltage	
Output current	0.3 A
	0.6 A
	1.2 A
	2 A
	2.5 A
	3 A
	3.5 A
	4 A
	5 A
	6 A
	10 A
	20 A
	30 A
	40 A

--- 5 V	--- 12 V	--- 24 V	--- 48 V
		ABL8MEM24003	
		ABL8MEM24006	
		ABL8MEM24012	
	ABL8MEM12020		
		ABL7RM24025	ABL7RP4803
		ABL8REM24030	
ABL8MEM05040			
	ABL7RP1205	ABL8REM24050	

Pages

Please consult our web site www.schneider-electric.com

5

ABL4: 85 to 960 W - Compact - Rail mounting

Function modules ABL 8DCC: converters ---/---



~ 100...230 V	~ 120 V or ~ 230 V	~ 400...500 V	--- 24 V
Single-phase (N-L1) connection	Single-phase (N-L1) connection or 2-phase (L1-L2) connection	–	–
–	Single-phase (N-L1) connection	3-phase (L1-L2-L3) connection	–
–	–	3-phase (L1-L2-L3) connection	–
No	No	No	–
Yes, current limitation Automatic reset on elimination of the fault			Yes, current limitation
Yes	Yes	Yes	Yes, depending on model
Yes with buffer module, battery and battery check modules, redundancy module and discriminating downstream protection module			
Depending on model: 1.5 to 1.7 In for 5 to 30 seconds			No

--- 24 V	--- 5 V	--- 7...12 V
		ABL8DCC12020 (1)
ABL4RSM24035		
ABL4RSM24050		
		ABL8DCC05060 (1)
	ABL4RSM24100	
	ABL4RSM24200	ABL4WSR24200
		ABL4WSR24300
		ABL4WSR24400

Please consult our web site www.schneider-electric.com (2)

(1) Converter module ---/---, must be used with a Phaseo power supply.

(2) Certain offers can not be marketed in certain countries, please consult your "Customer Care Centre".

Applications

Display of graphic pages

Type of terminal

Small Panels with touch screen



Display	Type
	Capacity

Monochrome STN LCD (200 x 80 pixels), backlit - Green, orange and red, or - White, pink and red	Colour QVGA TFT LCD (320 x 240 pixels)	
3.4" (monochrome)	3.5" (colour)	5.7" (colour)

Data entry

Via touch screen

Memory capacity	Application
	Expansion

16 MB Flash
–

Functions	Maximum number of pages
	Variables per page
	Representation of variables
	Recipes
	Curves
	Alarm logs
	Real-time clock
	Alarm relay
	Buzzer

Limited by internal FLASH EPROM memory capacity
Unlimited
Alphanumeric, bitmap, bargraph, gauge, curves, buttons, LEDs
32 groups of 64 recipes
Yes, with log
Yes
Access to the PLC real-time clock
–
Yes

Communication	Asynchronous serial link
	Downloadable protocols
	Printer link
	USB ports
	Networks

RS 232C/RS 485 (1) RS 232C using Zelio protocol (2)	RS 232C/RS 485
Uni-TE, Modbus and for PLC brands: Allen-Bradley, Omron, Mitsubishi, Siemens	
USB for serial or parallel printer	
1 host type A and 1 device type mini-B	
1 Ethernet TCP/IP port (10BASE-T/100BASE-TX) (3)	1 Ethernet TCP/IP port (10BASE-T/100BASE-TX)

Development software
Operating system

Vijeo Designer (on Windows XP, Windows Vista and Windows 7)
Magelis

References



HMI STO 500	HMI STU 655	HMI STU 855
--------------------	--------------------	--------------------

Page

Please consult our web site www.schneider-electric.com

(1) Only HMI STO 511/512.
(2) Only HMI STO 501.
(3) Only HMI STO 531/532.



Display of text messages and/or semi-graphic pages		Display of text messages and/or semi-graphic pages Control and configuration of data	
Small Panels with keypad		Small Panels with keypad	
Small Panels with keypad		Small Panels with touch screen and keypad	
			
Green backlit monochrome LCD, height 5.5 mm (0.217 in.) or Green, orange or red backlit monochrome LCD, height 4.34...17.36 mm (0.171...0.683 in.)		Green, orange or red backlit monochrome LCD, height 4.34...17.36 mm (0.171...0.683 in.)	
2 lines of 20 characters or 1 to 4 lines of 5 to 20 characters (monochrome)		1 to 4 lines of 5 to 20 characters (monochrome)	
Via keypad with 8 keys (4 customizable)		Via keypad with ■ 12 function keys or numeric entry (depending on context) ■ 8 service keys	
512 KB Flash		512 KB Flash EPROM	
128/200 application pages 256 alarm pages 40...50		128/200 application pages 256 alarm pages 40...50, bargraph, buttons, LEDs	
Alphanumeric		Alphanumeric, bargraph, buttons, LEDs	
Yes		Yes	
Yes (5)		Yes	
Access to the PLC real-time clock		Access to the PLC real-time clock	
-		Yes (4)	
RS 232C/RS 485			
Uni-TE, Modbus and for PLC brands: Allen-Bradley, Omron, Mitsubishi, Siemens			
RS 232C serial link (5)			
-			
-			
Vijeo Designer Lite (on Windows 2000, Windows XP and Windows Vista)			
Magelis			

XBT N ●●●●	XBT R ●●●	XBT RT ●●●
-------------------	------------------	-------------------

Please consult our web site www.schneider-electric.com
(4) Only XBT RT511.
(5) Depending on model.

Associated offers

Operator dialogue terminals

Magelis™ GT Advanced Panels

Applications	Display of text messages, graphic objects and synoptic views Control and configuration of data
Type of terminal	Touch screen Advanced Panels



Display	Type	Backlit monochrome (amber or red mode) STN LCD (320 x 240 pixels) or TFT LCD	Backlit monochrome or colour STN LCD or backlit colour TFT LCD (320 x 240 pixels) or (640 x 480 pixels) (3)	Backlit colour STN LCD or colour TFT LCD (640 x 480 pixels)	
	Capacity	3.8" (monochrome or colour)	5.7" (monochrome or colour)	7.5" (colour)	
Data entry	Static function keys	Via touch screen			
	Dynamic function keys	-			
	Service keys	-			
	Alphanumeric keys	-			
		-			
Memory capacity	Applications	32 MB Flash EPROM	16 MB Flash EPROM (3)	32 MB Flash EPROM	
	Expansion	-	By means of 128, 256, 512 MB, 1, 2 or 4 GB CF card (except XBT GT2110)		
Functions	Maximum number of pages	Limited by internal Flash EPROM memory capacity	Limited by capacity of internal Flash EPROM memory or CF card memory		
	Variables per page	Unlimited (8000 variables max.)			
	Representation of variables	Alphanumeric, bitmap, bargraph, gauge, tank, tank level indicator, curves, polygon, button, LED			
	Recipes	32 groups of 64 recipes comprising 1024 ingredients max.			
	Curves	Yes, with log			
	Alarm logs	Yes			
	Real-time clock	Built-in			
	Discrete I/O	-		1 input (reset) and 3 outputs (alarm, buzzer, run)	
	Multimedia I/O	-	(3)	1 audio input (microphone), 1 composite video input (digital or analogue video camera), 1 audio output (loudspeaker) (1)	
	Communication	Downloadable protocols	Uni-TE (2), Modbus, Modbus TCP/IP (1) and for PLC brands: Mitsubishi, Omron, Allen-Bradley and Siemens		
		Asynchronous serial link	RS 232C/485 (COM1)	RS 232C/RS 422/485 (COM1) and RS 485 (COM2)	
USB ports		1	1 (3)	1	
Bus and networks		-	Modbus Plus and Fipway with USB gateway, PROFIBUS DP and Device Net with optional card		
		Ethernet TCP/IP (10BASE-T/100BASE-TX) (1)			
Printer link		USB port for parallel printer	RS 232C (COM1) serial link, USB port for parallel printer		
Development software	Vijeo Designer (on Windows XP, Windows Vista and Windows 7)				
Operating system	Magelis (200 MHz RISC CPU)	Magelis (133 MHz RISC CPU) (3)	Magelis (266 MHz RIS CPU)		
Type of terminal	XBT GT11/13	XBT GT21/22/23/24/29	XBT GT42/43		
Page	Please consult our web site www.schneider-electric.com				

(1) Depending on model.
 (2) Uni-TE version V2 for Twido controller and TSX Micro/Premium platform.
 (3) For XBTGT 2430, 32 MB Flash EPROM, 1 sound output, 2 USB ports, 266 MHz RISC CPU.
 (4) For XBT GT 5430.



**Display of text messages, graphic objects and synoptic views
Control and configuration of data**

Touch screen Advanced Panels



Backlit colour STN LCD or colour TFT LCD
(640 x 480 pixels or 800 x 600 pixels) (4)

Backlit colour TFT LCD (800 x 600 pixels)

Backlit colour TFT LCD (1024 x 768 pixels)

10.4" (colour)

12.1" (colour)

15" (colour)

Via touch screen

–
–
–
–

32 MB Flash EPROM

By means of 128, 256, 512 MB, 1, 2 or 4 GB CF card

Limited by capacity of internal Flash EPROM memory or CF card memory

Unlimited (8000 variables max.)

Alphanumeric, bitmap, bargraph, gauge, tank, tank level indicator, curves, polygon, button, LED

32 groups of 64 recipes comprising 1024 ingredients max.

Yes, with log

Yes

Built-in

1 input (reset) and 3 outputs (alarm, buzzer, run)

1 audio input (microphone), 1 composite video input (digital or analogue video camera), 1 audio output (loudspeaker) (1)

Uni-TE (2), Modbus, Modbus TCP/IP (1) and for PLC brands: Mitsubishi, Omron, Allen-Bradley and Siemens

RS 232C/RS 422/485 (COM1) and RS 485 (COM2)

2

Modbus Plus with USB gateway

Ethernet TCP/IP (10BASE-T/100BASE-TX)

RS 232C (COM1) serial link, USB port for parallel printer

Vijeo Designer (on Windows XP, Windows Vista and Windows 7)

Magelis

(266 MHz RIS CPU)

XBT GT52/53/54

XBT GT63

XBT GT73

Please consult our web site www.schneider-electric.com

Associated offers

Operator dialogue terminals

Magelis™ GK, GH and GTW Advanced Panels

Applications	Display of text messages, graphic objects and synoptic views Control and configuration of data	
Type of terminal	Advanced Panels with keypad	
		
Display	Type	Colour TFT LCD (320 x 240 pixels) or monochrome STN
	Capacity	5.7" (monochrome or colour)
		Colour TFT LCD (640 x 480 pixels)
		10.4" (colour)
Data entry	Via keypad and/or touch screen (configurable) and/or by industrial pointer	
	Static function keys	10
	Dynamic function keys	14
	Service keys	8
	Alphanumeric keys	12
Memory capacity	Application	16 MB Flash EPROM
	Expansion	32 MB Flash EPROM
		By means of 128, 256, 512 MB, 1, 2 or 4 GB CF card
Functions	Maximum number of pages	Limited by capacity of internal Flash EPROM memory or CF card memory
	Variables per page	Unlimited (8000 variables max.)
	Representation of variables	Alphanumeric, bitmap, bargraph, gauge, tank, tank level indicator, curves, polygon, button, LED
	Recipes	32 groups of 64 recipes comprising 1024 ingredients max.
	Curves	Yes, with log
	Alarm logs	Yes
	Real-time clock	Built-in
	Discrete I/O	–
	Multimedia I/O	1 input - 3 outputs
		–
Communication	Downloadable protocols	Uni-TE (2), Modbus, Modbus TCP/IP (1) and for PLC brands: Mitsubishi, Omron, Allen-Bradley and Siemens
	Asynchronous serial link	RS 232C/RS 422/485 (COM1) RS 485 (COM2)
	USB ports	1
	Bus and networks	2
		Modbus Plus, Fipway with USB gateway, PROFIBUS DP and Device Net with optional card
		Ethernet TCP/IP (10BASE-T/100BASE-TX)
	Printer link	RS 232C (COM1) serial link, USB port for parallel printer
Development software	Vijeo Designer (on Windows XP, Windows Vista and Windows 7)	
Operating system	Magelis (CPU 266 MHz RISC)	
Type of terminal	XBT GK 21/23	XBT GK 53
Page	Please consult our web site www.schneider-electric.com	

(1) Depending on model.
(2) Uni-TE version V2 for Twido controller and TSX Micro/Premium platform.



**Display of text messages, graphic objects and synoptic views
Control and configuration of data**

Portable Advanced Panels

Open touch screen Advanced Panels



Colour TFT LCD (640 x 480 pixels)	Colour TFT LCD (800 x 600 pixels)	Colour TFT LCD (800 x 600 pixels)	Colour TFT LCD (1024 x 768 pixels)
5.7" (colour)	8.4" (colour)	12" (colour)	15" (colour)
Via touch screen	Via touch screen		
11	-		
-	-		
-	-		
-	-		
32 MB Flash EPROM	1 GB CF system card included with terminal, expandable to 4 GB	2 GB CF system card included with terminal, expandable to 4 GB	
By means of 128, 256, 512 MB, 1, 2 or 4 GB CF card			
Limited by capacity of internal Flash EPROM memory or CF card memory			
Unlimited (8000 variables max.)			
Alphanumeric, bitmap, bargraph, gauge, tank, tank level indicator, curves, polygon, button, LED			
32 groups of 64 recipes comprising 1024 ingredients max.			
Yes, with log			
Yes			
Built-in			
-			
1 audio output			
Uni-TE (2), Modbus, Modbus TCP/IP and for PLC brands: Mitsubishi, Omron, Rockwell Automation and Siemens	Uni-TE (2), Modbus, Modbus TCP/IP (1) and for PLC brands: Mitsubishi, Omron, Allen-Bradley and Siemens		
RS 232C/RS 422-485 (COM1)	RS 232C (COM1) RS 232C (COM2)	RS 232C (COM1)	RS 232C (COM1) RS 232C (COM2)
1	4	4 + 1 on front	
-	Modbus Plus with USB gateway		
1 Ethernet port (10BASE-T/100BASE-TX)	1 TCP/IP Ethernet port (10BASE-T/100BASE-TX) and 1 Ethernet port (10BASE-T/100BASE-TX/1 GB)		
-	RS 232C (COM1 or COM2) serial link, USB port for parallel printer		
Vijeo Designer (on Windows XP, Windows Vista and Windows 7)			
Magelis (266 MHz RISC CPU)	Windows XP Embedded		

XBT GH 2460

XBT GTW 450

XBT GTW 652

HMI GTW 7353

Please consult our web site www.schneider-electric.com

(1) Depending on model.

(2) Uni-TE version V2 for Twido controller and TSX Micro/Premium platform.

Magelis™ GTO Optimum Advanced Panels

The new operator terminal standard for Machine Builders

> State of the art display

- > The 5 screen size range consists a 65 Kcolour TFT screen and provides a better visualisation
- > The design of the panel, with its LED backlight, allows energy saving and dimming functionality



5



- > The 7" wide screen provides a 40% increase in the available screen area.
- > The external keypad, also available with the 3,5" screen, allows the screen area to provide maximum information.

> Optimized communication

- > Magelis GTO offers remote control access and embedded Ethernet provides easy integration in your IT structure
- > The up to date peripheral links enable easy operating use as well as an easy maintenance

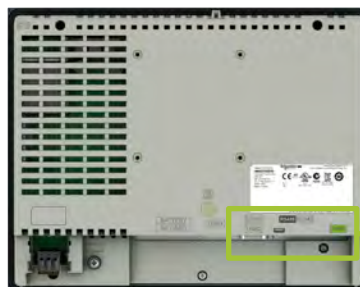

> Easy to install and sustainable offer

With Magelis GTO, you can rely on a long term investment

- > The existing cut-out is the same size for the new range, enabling you an immediate installation when your current panel needs to be replaced
- > The configuration tool (Vijeo Designer software) is also the same to enable an immediate restart of the operations



The installation is made easy with:

- > only 4 installation fasteners for the whole range
- > unique fast connection power plug for the whole range
- > the connectors located in the same place on the panel for a better wiring



5

> Magelis GTO is part of Machine solution

- > Included in SoMachine V3.1



Selection guide: see page 5/42

Associated offers

Operator dialogue terminals

Magelis™ GTO Optimum Advanced Panels

Applications	Display of text messages, graphic objects and synoptic views Control and configuration of data
Type of terminal	Optimum Advanced Panels, touch screen
Degree of protection (according to IEC 60529)	IP 65 (IP 67 with addition of a cover)



Display	Type	Colour TFT LCD, backlit 320 x 240 pixels (QVGA)		Colour TFT LCD, backlit 800 x 480 pixels (WVGA)
	Capacity	3.5"	5.7"	7.0 Wide
Data entry		Via touch screen	Via touch screen	Via touch screen
	Static function keys	6 function keys (static or dynamic)	–	8 function keys (static or dynamic)
	Dynamic function keys	–	–	–
	Service keys	–	–	–
	Alphanumeric keys	–	–	–
Memory capacity	Applications	64/96 MB Flash EPROM (1)		96 MB Flash EPROM
	Expansion	–	By 4 GB SD card (except HMI GTO2300)	
Functions	Maximum number of pages	Limited by internal Flash EPROM memory capacity	Limited by capacity of internal Flash EPROM memory or of SD card	
	Variables per page	Unlimited (8000 variables max.)		
	Representation of variables	Alphanumeric, bitmap, bargraph, gauge, tank, tank level indicator, curves, polygon, button, LED		
	Recipes	32 groups of 64 recipes comprising 1024 ingredients max.		
	Curves	Yes, with log		
	Alarm logs	Yes		
	Real-time clock	Built-in		
	Discrete I/O	–		
	Multimedia I/O	–		
	Communication	Downloadable protocols	Uni-TE (2), Modbus, Modbus TCP/IP (1) and for PLC brands: Mitsubishi, Omron, Allen-Bradley and Siemens	
Asynchronous serial link		RS 232C (COM1) and RS 485 (COM2) except HMI GTO1310: RS 232C/485 (COM1)		
USB ports		1 type A host connector + 1 mini-B connector		
Buses and networks		Ethernet TCP/IP (10BASE-T/100BASE-TX) (3), Modbus Plus and Fipway via USB gateway		
Printer link		RS 232C (COM1) serial link (4) and USB port for parallel printer		
Development software	Vijeo Designer (on Windows XP and Windows 7)			
Operating system	Magelis (333 MHz RISC CPU)			
Type of terminal	HMI GTO1300 HMI GTO1310	HMI GTO2300 HMI GTO2310	HMI GTO3510	
Page	Please consult our web site www.schneider-electric.com			

(1) Depending on model.
 (2) Uni-TE version V2 for Twido controller and TSX Micro/Premium platform.
 (3) Except HMI GTO1300 and GTO2300 (Modbus Plus and Fipway via USB gateway only).
 (4) Except HMI GTO1310 (USB port for parallel printer only).



Display of text messages, graphic objects and synoptic views
Control and configuration of data

Optimum Advanced Panels, touch screen

Optimum Advanced Panels, touch screen, "Stainless Steel" version

IP 65 (IP 67 with addition of a cover)

IP 66K (Front panel with stainless steel frame) for food & beverage environment



Colour TFT LCD, backlit 640 x 480 pixels (VGA) 7.5"	Colour TFT LCD, backlit 640 x 480 pixels (VGA) 10.4"	Colour TFT LCD, backlit 800 x 600 pixels (SVGA) 12.1"	Colour TFT LCD, backlit 320 x 240 pixels (QVGA) 5.7"	Colour TFT LCD, backlit 640 x 480 pixels (VGA) 10.4"	Colour TFT LCD, backlit 800 x 600 pixels (SVGA) 12.1"
---	--	---	--	--	---

Via touch screen

–
–
–
–

96 MB Flash EPROM

By 4 GB SD card

Limited by capacity of internal Flash EPROM memory or of SD card

Unlimited (8000 variables max.)

Alphanumeric, bitmap, bargraph, gauge, tank, tank level indicator, curves, polygon, button, LED

32 groups of 64 recipes comprising 1024 ingredients max.

Yes, with log

Yes

Built-in

–
–

Uni-TE (2), Modbus, Modbus TCP/IP (1) and for PLC brands: Mitsubishi, Omron, Allen-Bradley and Siemens

RS 232C (COM1) and RS 485 (COM2)

1 type A host connector + 1 mini-B connector

Ethernet TCP/IP (10BASE-T/100BASE-TX), Modbus Plus and Fipway via USB gateway

RS 232C (COM1) serial link and USB port for parallel printer

Vijeo Designer (on Windows XP and Windows 7)

Magelis (333 MHz RISC CPU)

HMI GTO4310 **HMI GTO5310** **HMI GTO6310** **HMI GTO2315** **HMI GTO5315** **HMI GTO6315**

Please consult our web site www.schneider-electric.com

5

Associated offers

OsiSense™ for pumping applications
OsiSense XM pressure sensors

OsiSense XM pressure sensors

> Select OsiSense XM sensor in terms of pumping applications

> Medium duty from 0 to 25 bar



Electronic pressure transmitters for control circuit type XMLA, with fixed differential: detection of a single threshold



Electronic pressure transmitters for control circuit type XMLB with adjustable differential: regulation between 2 thresholds



Electromechanical pressure switches for control circuit type XMX



Electromechanical pressure switches for control circuit type XMA

> Over 25 bar & high end



Electronic pressure transmitters for control circuit type XMLK



Electronic pressure transmitters for control circuit type XMLP

> Light duty from 0 to 8 bar: Small pumps up to 3 HP



Electromechanical pressure switches for power circuit type FTG with fixed differential: detection of a single threshold



Electromechanical pressure switches for power circuit type FSG with adjustable differential: regulation between 2 thresholds

> Medium duty from 0 to 25 bar : Mid-power pumps up to 4 HP



Electromechanical pressure switches for power circuit type FYG with adjustable differential: regulation between 2 thresholds, 2 contacts



Electromechanical pressure switches for power circuit type XMP with adjustable differential: regulation between 2 thresholds, 2 or 3 contacts

Associated offers

OsiSense™ for pumping applications
OsiSense XM pressure sensors

> How to choose a pressure sensor in 4 steps?

- 1 **Choose a product line according to application**
 - > Need to follow a pressure: electronic product with analogue output (0-10v / 4-20mA / 0,5-4,5v)
 - > Need to manage threshold with quick response time: electronic product with solid state output
 - > Need to manage threshold without constraint of response time: electromechanical product with contact is a good choice
- 2 **Choose a product according to the pressure**
 - > 6, 10, 16 or 25 bar are common for water booster, more for fire booster
- 3 **Choose the fluid connection according habits (geographical use)**
 - > ¼ BSP, ¼ NPT, G ¼ A, ...
- 4 **Choose the electrical connection according habits**
 - > Cable, connector (M12, DIN, Packard, ...), screw clamp terminals

> OsiSense XMLK optimum pressure transmitter for pumps



- > Complete pressure solution with bar/psi and with XMx, XMP or FSG power pressure switches
 - > International range
 - > 6, 10, 16 bar
 - > ¼ gaz fluid connection
 - > DIN43650A, M12 & Metripack electrical connections
 - > 4...20 mA or 0...10 V analog output
 - > 56 new references in catalog
 - > EAC customization capabilities
- > Advanced control solution with ATV32 and ATV61 variable speed drives, M238 and M258 Modicon controllers

> OsiSense XMLP optimum pressure transmitter for Hydraulics & HVAC



- > Compact full metal pressure transmitter for hydraulic and HVAC machinery
 - > 0...600 bar product range
 - > M12, DIN, GDS207 electrical connections
 - > G1/4A, 7/16-20 UNF-2A, 7/16-20 UNF-2B pressure connections
 - > 4-20 mA, 0-10 V, 0-5 V, 0.5-4.5 V outputs
 - > - 30...+100 °C (-22...+ 212 °F) temperature range



Connect with the experts



- > A dedicated Sales team: trained and experienced sales professionals are available to help you with any sensing application.
- > Telemecanique Sensors teams: are available for pre and post sales support. We become an extension of your team and we share our expertise with you.

<http://www.tesensors.com>

Application

Control of 3-phase supplies

Functions

- Phase sequence
- Phase failure
- Asymmetry

- Phase sequence
- Phase failure
- Undervoltage

- Phase sequence
- Phase failure
- Asymmetry
- Overvoltage and undervoltage

- Phase sequence
- Phase failure
- Motor temperature

Modular type (17.5 or 35 mm width)



Values controlled

~ 208...480 V
~ 208...440 V

~ 208...480 V

~ 208...480 V
~ 220...480 V

~ 208...480 V

Output

1 or 2 C/O contacts

1 C/O

1 or 2 C/O contacts

2 N/O contacts

Size

17.5 mm

17.5 mm

17.5 or 35 mm

35 mm

Modular relay type

TG●0
RM17 TT00
RM17 TA00

RM17 TU00

RM17 TE00
RM35 TF30

RM35 TM●50
MW

More information

Please consult on our web site www.schneider-electric.com

Industrial type (22.5 ou 45 width)



Values controlled

~ 220...440 V
~ 220...240 V
~ 380...440 V

~ 220...440 V
~ 220...240 V
~ 380...440 V

—

—

Output

1 or 2 C/O contacts

1 or 2 C/O contacts

—

—

Size

22.5 mm

22.5 mm

—

—

Industrial relay type

RM4 TG20
RM4 TA●●

RM4 TU●●
RM4 TR●●

—

—

More information

Please consult on our web site www.schneider-electric.com

5



More technical information on www.schneider-electric.com . . . please consult the end pages of this catalogue

Voltage control			Current control		
-----------------	--	--	-----------------	--	--

3-phase - Overvoltage and undervoltage between phases - Overvoltage and undervoltage between phases and neutral - Absence of neutral / phase	Single-phase and d.c. - Overvoltage or undervoltage - Self-powered			Integrated current transformer - Overcurrent	- - Overcurrent or undercurrent
	- Overvoltage or undervoltage	- Overvoltage and undervoltage in window mode	- Overvoltage or undervoltage		
	- Self-powered	- Self-powered			



\sim 220...480 V \sim 208...480 V \sim 120...277 V	\equiv 9...15 V \sim/\equiv 20...80 V \sim/\equiv 65...260 V	\sim/\equiv 20...80 V \sim/\equiv 65...260 V	\sim/\equiv 0.05...5 V \sim/\equiv 1...100 V \sim/\equiv 15...600 V	2...20 A	2...500 mA 0,15...15 A
1 C/O contact or 1 C/O contact + 1 C/O contact	1 C/O contact	1 C/O contact	2 C/O contacts	1 C/O contact	2 C/O contacts
17.5 or 35 mm	17.5 mm	17.5 mm	35 mm	17.5 mm	35 mm
RM17 UB310 RM35 UB3●●●	RM17 UAS1●	RM17 UBE1●	RM35 UA1●MW	RM17 JC00MW	RM35 JA3●MW

5

Please consult on our web site www.schneider-electric.com



-	-	\sim/\equiv 80...220 V \sim/\equiv 160...300 V	0.05...5 V 1...100 V 30...500 V	-	3 mA...1 A 0.3...15 A
-	-	2 C/O contacts	2 C/O contacts	-	1 or 2 C/O contacts
-	-	22.5 mm	22.5 mm	-	22.5 or 45 mm
-	-	RM4 UB3●	RM4 UA3● RM4 UA1●	-	RM4 JA01 RM4 JA3●

Please consult on our web site www.schneider-electric.com

Application	Level control	Pump control	
Functions	By resistive probes - Empty or fill	By discrete sensor - Empty or fill - Input for discrete sensor AON: Contact/PNP/NPN	3-phase and single-phase - Overcurrent and undercurrent - Phase sequence on 3-phase supply - Phase failure on 3-phase supply

Modular type (17.5 or 35 mm width)



Values controlled	0.25...5 kΩ 5...100 kΩ 0.05...1 MΩ	–	Current: 1...10 A 3-phase ~ 208...480 V Single-phase ~ 230 V
Output	2 C/O contacts	1 C/O contact	1 C/O contact
Size	35 mm	35 mm	35 mm
Modular relay type	RM35 LM33MW	RM35 LV14MW	RM35 BA10

More information Please consult on our web site www.schneider-electric.com

Industrial type (22.5 or 45 mm width)



Industrial type	Values controlled	2.5...50 kΩ 5...100 kΩ 25...500 kΩ	5...100 kΩ	–
	Output	1 or 2 C/O contacts	1 or 2 C/O contacts	–
	Size	22.5 mm	39 mm (plug-in 8 or 11-pin)	–
Industrial relay type		RM4 L	RM84	–

More information Please consult on our web site www.schneider-electric.com

5



Frequency control	Speed control	Temperature control for elevator machine rooms and 3-phase supplies	
- Over-frequency and under-frequency	- Over or under operating rate / speed	- Machine room temperature	- Machine room temperature - Phase failure and phase sequence
			
Mains supply: 50 or 60 Hz High threshold: - 2...+ 10 Hz Low threshold: - 10...+ 2 Hz	Time controlled between pulses: 0.05...0.5 s, 0.1...1 s, 0.5...5 s, 1...10 s 0.1...1 min, 0.5...5 min, 1...10 min	Temperature Low threshold: - 1...11 °C High threshold: 34...46 °C	Temperature Low threshold: - 1...11 °C High threshold: 34...46 °C 3-phase supplies ~ 208...480 V
1 C/O contact + 1 C/O contact	1 C/O contact	1 C/O contact or 2 N/O contacts	2 N/O contacts
35 mm	35 mm	35 mm	35 mm
RM35 HZ21FM	RM35 S0MW	RM35 ATL0MW RM35 ATR5MW	RM35 ATW5MW

Please consult on our web site www.schneider-electric.com

-	-	-	-
-	-	-	-
-	-	-	-
-	-	-	-
-	-	-	-

TWDXCAFD010	4/5	XBTZG935	3/14
TWDXCAFJ010	4/5	XBTZGCCAN	3/14
TWDXCAISO	4/4	XBTZGCHOK	3/14
TWDXCAT3RJ	4/4	XBTZGCLP2	3/14
V		XBTZGCLP4	3/14
VLT	5/18	XBTZGDIO1	3/14
VW3A8306D30	4/5	XBTZGDIO2	3/14
VW3A8306R03	4/5	XBTZGFIX	3/14
VW3A8306R10	4/5	XBTZGPWS1	3/14
VW3A8306R30	4/5	XBTZGUSB	3/14
VW3A8306RC	4/5	XBTZGUSBB	3/14
VW3A3521S0	3/7	XD2GA	5/23
VW3A3201	3/7	XD4PA	5/23
VW3A3202	3/7	XD5PA	5/23
VW3A8306TF03	4/4	XGSZ24	4/4
VW3A8306TF10	4/4	XVLA	5/22
VW3A8306R03	3/21		
VW3A8306R10	3/21		
VW3A8306R30	3/21		
X			
XALE	5/24		
XALF	5/25		
XALG	5/25		
XALD	5/24		
XALK	5/24		
XAPA	5/25		
XAPE	5/25		
XAPJ	5/25		
XAPM	5/25		
XAPS	5/25		
XB2SL	5/25		
XB4	5/22		
XB5R, XB4R	5/22		
XB5S	5/22		
XB5	5/22		
XB6	5/22		
XB7	5/23		
XBTZ9008	4/5		
XBTZ938	4/5		
XBTZ9980	4/5		
XBTZG60	3/14		
XBT9980	3/33		
XBTGC1100T	3/14		
XBTGC1100U	3/14		
XBTGC2120T	3/14		
XBTGC2120U	3/14		
XBTGC2230T	3/14		
XBTGC2230U	3/14		
XBTGH2460	5/33		
XBTGK21/23	5/32		
XBTGK53	5/32		
XBTGT11/13	5/30		
XBTGT21/22/23/24/29	5/30		
XBTGT42/43	5/30		
XBTGT52/53/54	5/31		
XBTGT63	5/31		
XBTGT73	5/31		
XBTGTW450	5/32		
XBTGTW652	5/32		
XBTN●●●●	5/29		
XBTR●●●	5/29		
XBTRT●●●	5/29		
XBTZ938	3/33		
XBTZ9980	4/9		
XBTZ9980	3/21		
XBTZG51	3/14		
XBTZG52	3/14		
XBTZG62	3/14		

Schneider Electric Industries SAS

Head Office
35, rue Joseph Monier
F-92500 Rueil-Malmaison
France



www.schneider-electric.com/pumping

The information provided in this documentation contains general descriptions and/or technical characteristics of the performance of the products contained herein. This documentation is not intended as a substitute for and is not to be used for determining suitability or reliability of these products for specific user applications. It is the duty of any such user or integrator to perform the appropriate and complete risk analysis, evaluation and testing of the products with respect to the relevant specific application or use thereof. Neither Schneider Electric nor any of its affiliates or subsidiaries shall be responsible or liable for misuse of the information contained herein.

Design: Schneider Electric
Photos: Schneider Electric
Printed by: