

Sensors/switches/locks



Contents	Page
<i>Why should you use sensors/switches?</i> _____	9:2
<i>How safe is a switch/sensor?</i> _____	9:3
<i>Non-contact safety sensor Eden</i> _____	9:4
<i>Safety Interlock switch JSNY5</i> _____	9:8
<i>Magnetic Switch JSNY7</i> _____	9:10
<i>Safety Interlock Switch JSNY8</i> _____	9:12
<i>Safety Interlock Switch JSNY9</i> _____	9:14
<i>Magnetic lock Magne</i> _____	9:16
<i>Process lock Dalton</i> _____	9:22
<i>Safety lock Knox</i> _____	9:28

Descriptions and examples in this book show how the products work and can be used. This does not mean that they can meet the requirements for all types of machines and processes. The purchaser/user is responsible for ensuring that the product is installed and used in accordance with the applicable regulations and standards. We reserve the right to make changes in products and product sheets without previous notice. For the latest updates, refer to www.abb.com/lowvoltage. 2011.

Why should you use sensors/switches?

- to supervise doors and hatches around dangerous machines!

Assurance that a machine stops when a door or a hatch is opened can be solved by using different types of switches and sensors which are monitored with a safety relay or a safety PLC. Switches and sensors are available both as non-contact (dynamic or magnetic) and various types of interlocking devices. Interlocking devices can be used when it is required, via a signal, to lock a gate during processes that cannot be stopped during certain operations. They are also used with machines that have a long stopping time to prevent someone from entering before the machine has stopped.



- to ensure that a position is reached!

The sensor monitors that the robot is standing still in a monitored position when someone enters the robot's working area. The robot is then only stopped by the program. If the robot leaves the position the power will be cut directly. This is used when the robot does not stop safely without restarting problems.

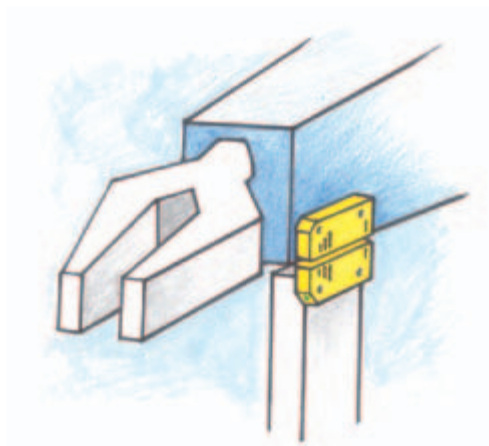

- to manage the safety in harsh environments!

Non-contact dynamic sensors have a long lifetime because they are not physically mechanically operated. They also endure very harsh environments, e.g. cold, heat, high-pressure wash-down which is important in the food industry for example. Because the sensors are small, they are very easy to position and can even be completely concealed in doors and hatches.



Eden - highest safety level and reliability

Our recommendation is to use the Eden sensor because it is the safest and most reliable solution. The Eden sensor is a non-contact switch and has a dynamic function. Also it is possible to connect up to 30 Eden sensors in series and still achieve PL e according to 13849-1.

What requirements should one have on sensors/switches?

The sensor/switch shall be reliable from both the safety and production point of view.

- A person must be able to trust that dangerous movements and functions are safely stopped by the sensors/switches.
- From the production point of view unintentional stops should be avoided.
- Standard EN ISO 13 855 now includes requirements for safety distances for interlocked doors without locking function.

Safety level

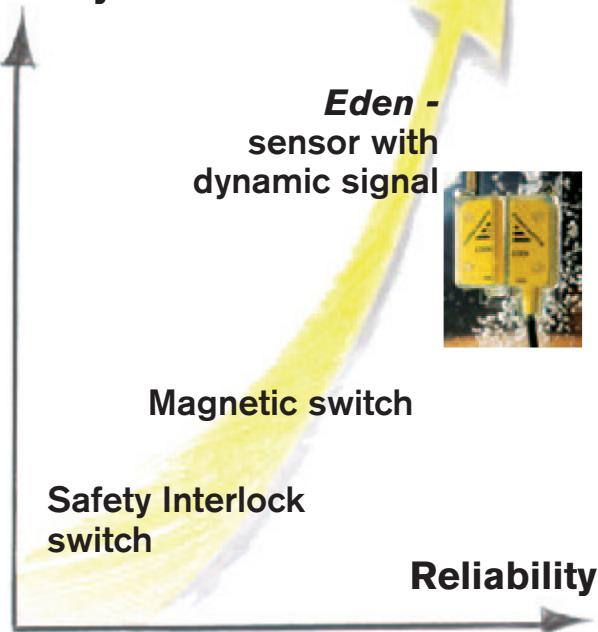

How safe is a sensor/switch?

In order to trust the safety function it is essential to be aware that a safety sensor/switch must be mounted and be used according to the specifications. The certification authorities only test the product according to the appropriate standards and to the specifications from the manufacturer.

Mechanical switches

For mechanical switches, e.g. key operated, this means that a door or a hatch has to be constructed to small tolerances in order for the switch, the key or the mounting brackets to last according to the life time specification from the supplier. The screws holding the parts have to be locked in such a way that they cannot be loosened. In order to prevent material from getting into the slot for the key the environment has to be clean. If a door goes outside the design tolerances from wear, the screws loosen or material comes into the slot, this may lead to the interlocked switch not giving a stop signal when the door is opened. Even two mechanical switches on a door could fail to an unsafe state if the door somehow gets outside the tolerances of the switches. To prevent accidents the mechanical switch normally needs continuous checks of both the switch and the installation.

Non-contact sensors/switches

For non contact sensors the risks associated with mechanical switches (see above) do not exist. If screws, brackets or sensors get loose, it will lead to a stop signal. Therefore only one sensor with dual or dynamic function is needed in

order to reach the highest safety level. There are two types of non-contact sensors - active and passive. The active sensor, Eden, is constantly communicating via a dynamic signal between the two parts and any failure will directly lead to a stop signal. The passive type, a magnet switch, has two reed contacts which are activated by a coded magnet. Both the passive and the active sensors are checked every time a door is opened. From a safety point of view the active sensor, Eden, is to be preferred because it is checked constantly whereas the passive sensor is only checked when a door opens.

From the reliability point of view a long detection distance with large tolerances and a well defined on and off position is needed. The active sensor, Eden, fulfils these demands. A magnet switch has smaller tolerances and an intermediate position where only one contact opens. A bad installation or vibrations can lead to an unintentional stop if one contact opens and closes again. The supervision of a two channel system is based on both contacts having to be operated in order to permit a new start. In a dynamic safety circuit there is only one pulsed signal and therefore no intermediate position.

Non-contact safety sensor

Eden

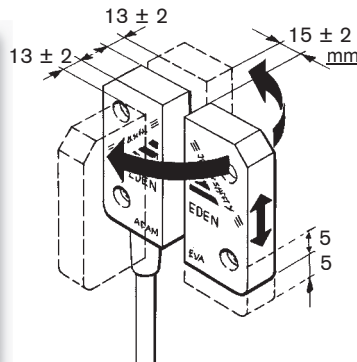

*Flexible mounting and
The ability to operate at
long distances.*

Approvals:



Safety sensor for:

- Doors and hatches
- Position control
- Sector detection
- Slot detection

Features:

- Cat. 4/PL e according to EN ISO 13849-1 together with Vital or Pluto
- Non-contact detection, large sensing distance 0 - 15 mm ± 2 mm
- Up to 30 sensors in series with the highest level of safety PL e
- Versatile mounting, 360° detection
- Protection class IP 67/IP69.
- The dynamic signal passes through wood and plastic (not metal)
- Status information with LED on the sensor and in the cable connection.
- Small hysteresis (< 1mm)

A non-contact safety sensor for the highest safety level

Eden - Adam and Eva is a non-contact safety sensor for use on interlocked gates, hatches etc. A coded signal is transmitted from the control device Vital or from the safety PLC Pluto via Adam to Eva which modifies the signal and sends it back again. The maximum sensing distance between Adam and Eva is currently 15 mm ± 2 mm.

Up to 30 Edens can be connected in series to Vital and still achieve the same safety level in the safety circuit. It is also possible to connect safety light beams and E-stops in the same safety circuit.

Adam is available with cable lengths up to 10 m and with M12 connectors. The LED on Adam provides indication of three different conditions, contact/non-contact between Adam and Eva and safety status. The same information is also available via the Adam connection cable. Eden E is available for harsh environments, as are Adam E and Eva E. Rapid blinking serves as an alignment aid. There are also coded versions, Eden C, Eden EC, Adam EC and Eva EC.

Application examples - Eden

Eden to detect position

Adam and Eva has contact only if they are within 15 mm from each other.

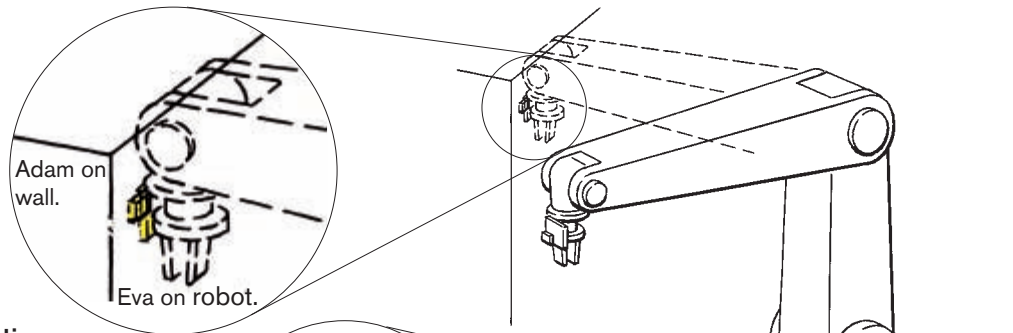

Eden used for sector detection

Metal stops the signal between Adam and Eva. Additional Eden sensor(s) can be mounted to detect metal plate(s) in place.

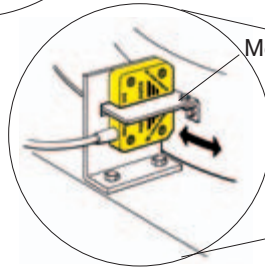

Eden used to detect the position of the saw guard.

Wood, plastic and other non-metallic materials let the signal pass between Adam and Eva.

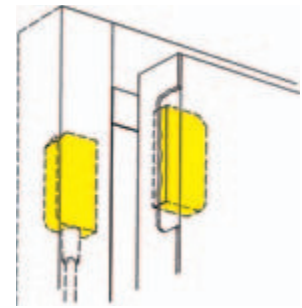
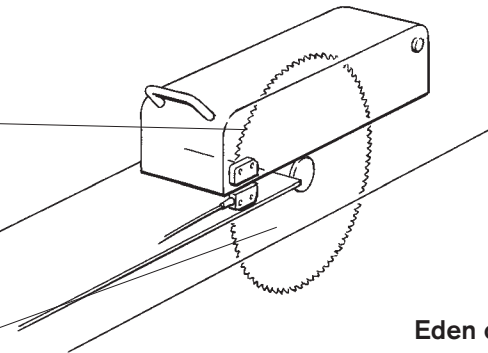
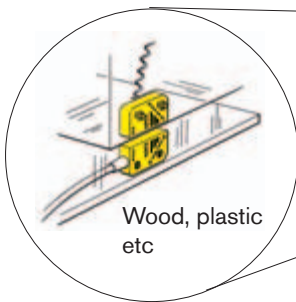

Eden can be hidden in doors and hatches

Non-metallic door material between Adam and Eva allows the signal through

Mounting – Eden

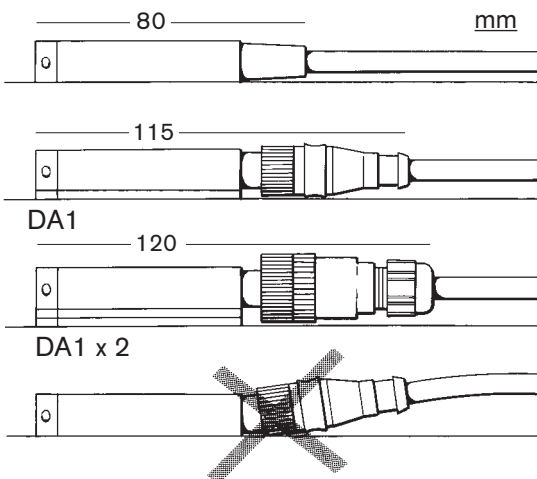

Mounting Adam with integral cable.

Mounting with one protection plate (DA1) for Adam M12 using prewired moulded M12 connector. For M12 connection, a straight contact is recommended.

Mounting with two protection plates (DA1) for Adam M12 using M12 connector with glanded cable.

Wrong mounting without protection plate may cause permanent damage to sensor.

Notes:

Four protection plates are supplied with Adam M12. To protect Adam and Eva protection plate (DA1) can be used on both sides.

DA2 mounting

The DA2 mounting spacer **must be** used in order to physically protect Eden from damage. Four spacers are provided with each Adam and Eva.

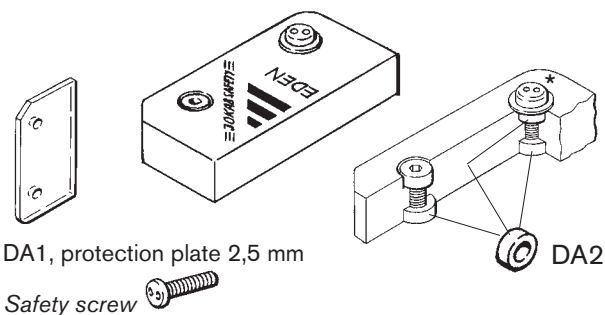

DA1, protection plate 2,5 mm

* Safety screw

Connection of Eden to Pluto

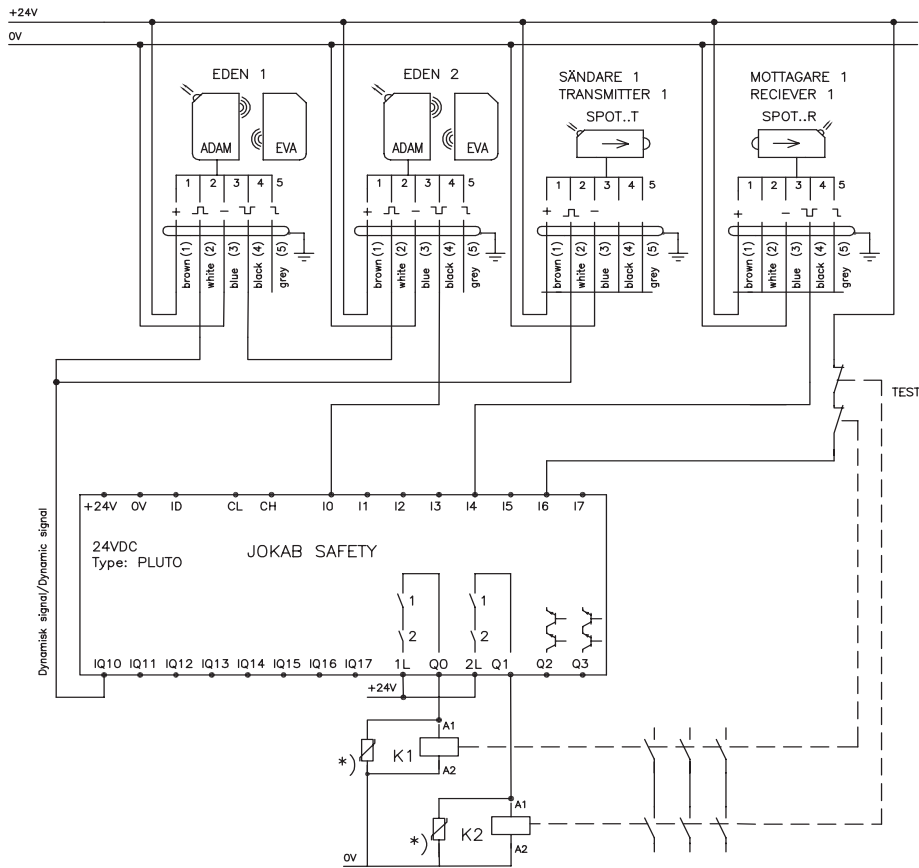

*)OBS: Använd alltid transientskydd t.ex. VDR!
 *)NOTE: Always use transient suppressors, e.g. VDR's!

Connection of Eden to Vital 1

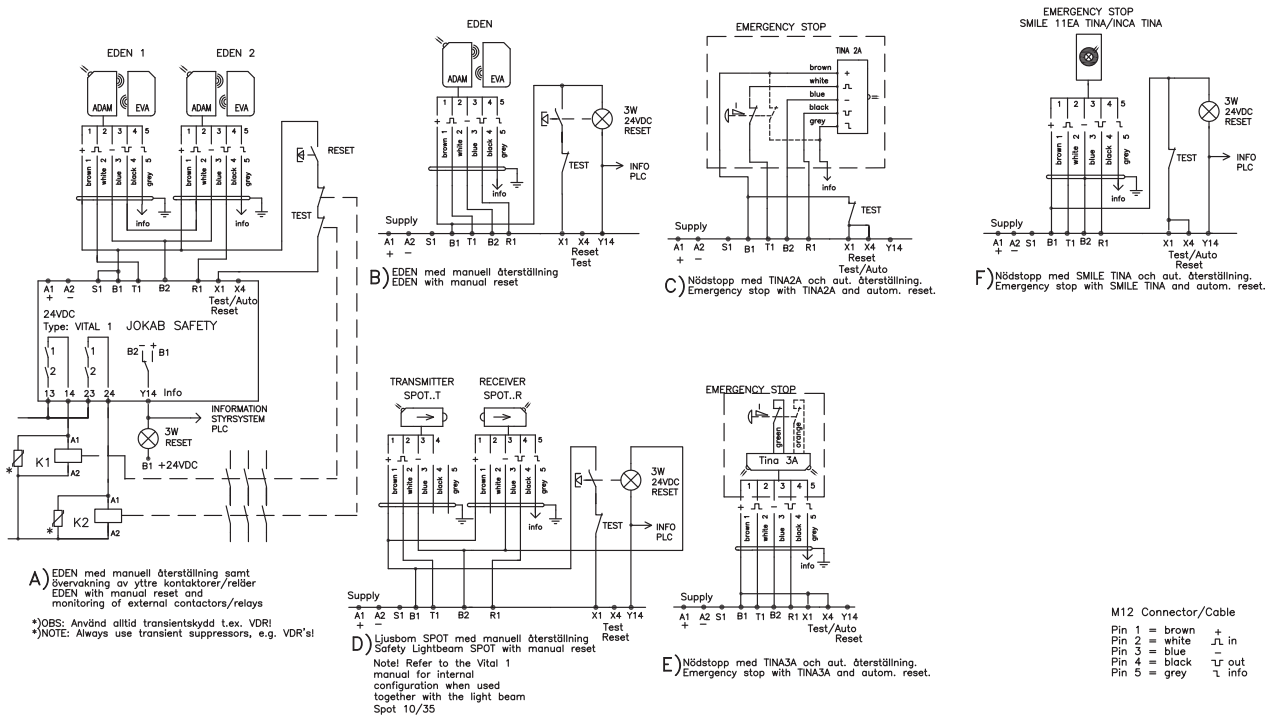

Technical data – Eden	
Manufacturer	ABB AB/Jokab Safety, Sweden
Article number/Ordering data:	
Eva*	2TLA020046R0000
Eva E*	2TLA020046R0600
Adam M12*	2TLA020051R0000
Adam 3 m*	2TLA020051R0200
Adam 10 m*	2TLA020051R0400
Adam 20 m	2TLA020051R0500
Adam E 10 m	2TLA020051R0600
Adam E 0,5 M12*	2TLA020051R0700
Adam E 20 m	2TLA020051R0800
* also available in grey	
Safety level	
IEC/EN 61508-1...7	SIL3
EN 62061	SIL3
EN ISO 13849-1	kat. 4/PL e
PFH_D	4,50 × 10 ⁻⁹
Colour	Yellow and black
Weight	Eva: 26 g Eva E: 36 g Adam M12: 30 g Adam 3 m: 220 g incl. cable Adam 10 m: 650 g incl. cable Adam E10 m: 660 g incl. cable Adam EC 10 m: 660 g incl. cable Adam E 0,5 m + M12: 100 g incl. cable
Power supply	24VDC + 15%-25%
Power consumption	Adam: without info output 45 mA with info output max 55 mA
Max cable length	see Vital technical data
Ambient temperature	
Eden/Eden C	-40°C ... +70°C (operation) -25°C ... +70°C (stock)
Eden E/EC	-40°C ... +70°C (operation) (Test ok +90°C ... +100°C) -25°C ... +70°C (stock)
Protection class	
Eden	IP67
Eden E	IP69K
Mounting	Installation Eden M4 screw, e.g. safety screw 20-053-42. Max. torque 2 Nm. Screw to be locked with Loctite or similar. Installation Eden E M4 screw, e.g. safety screw 20-053-42. Max. torque 2 Nm. Screw to be locked with Loctite or similar.
Detection distance max	
Adam/Eva 15 ± 2 mm	Flash 2 mm before red position.
Adam E/Eva E 12 ± 2 mm	Flash 2 mm before red position.
Hysteresis approx. 1 mm	
Metal may have influence on detection distance. This can be prevented by protection plates, DA1.	
Minimum distance to metal when there is metal on one or more sides.	
	One More
Adam/Eva	0 mm 2,5 mm
Adam E/Eva E	0 mm 0 mm
Minimum distance between Eden pairs	50 mm
Life	>10 ⁷ cycles

Material	Macromelt (Based on polyamid) Eden E for extreme surroundings.
Chemical resistance	
Macromelt:	Cutting oils, vegetable and animal oils, hydrogen peroxide, diluted acids and bases: good Alcohol and strong acids: not recommended
PU (EdenE):	Cutting oils, vegetable and animal oils, hydrogen peroxide, diluted acids and bases, alcohols: good Strong oxidating acids: not recommended
LED on Adam	
Green:	Eva within range, safety circuit closed (door closed)
Flashing:	Eva within range, earlier safety circuit open (door closed)
Red:	Eva out of range, safety circuit open (door open)
Fast flashing:	Eva is within 2 mm from maximum sensing distance (door closed)
Cable	3 or 10 m, ø 5.7mm, black, PVC 5 x 0.34mm ² + screen, UL 2464
Connector	M12: 5-pin male contact
Connections	
Brown (1)	+24 VDC
White (2)	Dynamic signal in
Blue (3)	0 VDC
Black (4)	Dynamic signal out
Grey (5)	Info output, see below
24 VDC when LED is green or flashing (tolerance -2 VDC), 10 mA max 0 VDC when LED is red. (tolerance +2 VDC)	
Warning: Incorrect connection may cause permanent damage to Adam devices.	
Conformity	2006/42/EG EN ISO 12100 1/2, EN 954-1, EN 60204-1, EN ISO 13849-1, EN 1088, GS-ET 15
Certifications	TÜV Nord CE

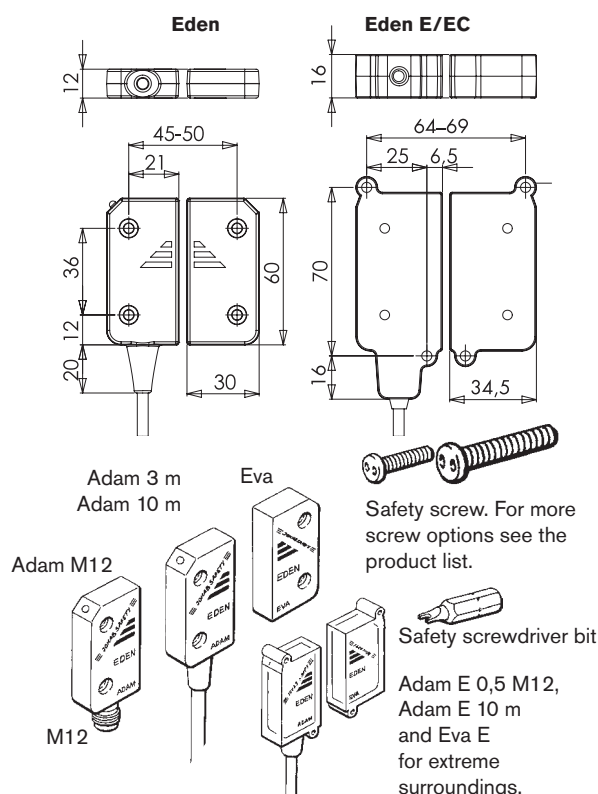

Safety Interlock switch

JSNY5

Approvals:



Application:

Gates
Hatches

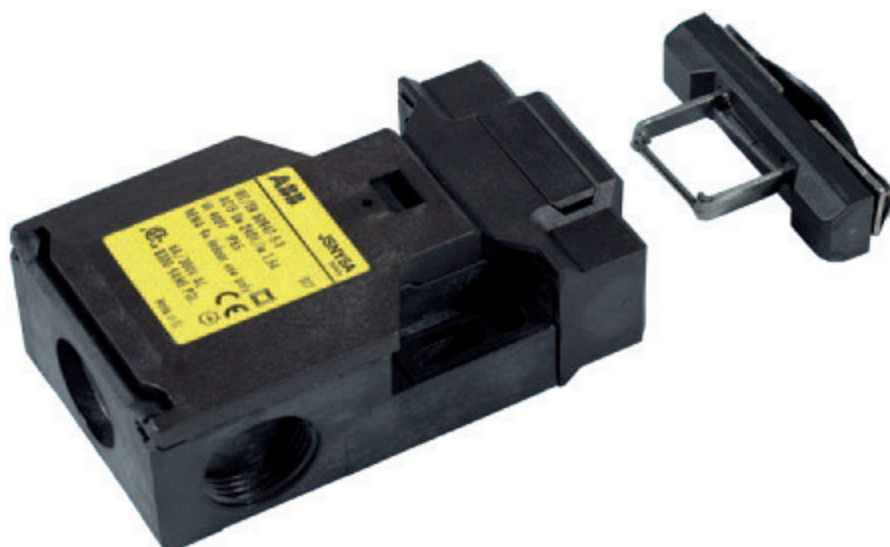

Features:

2 NC + 1 NO (actuator in)
4 actuating positions
Actuator holding force 10 or 30 N

Switch operational description

JSNY5 offers three contacts which gives both the two contacts needed for high safety level as well as a contact for the indication of operating status.

The advanced design offers the choice of four operating positions from only two actuator entries by simply rotating the head through 180°.

However, when installed and in its working condition only one entry can be used, ensuring no other element can tamper with the switch function.

When mounting the switch from the front two elongated holes are provided to aid alignment with two set screw holes for accurate fixing. Top fixing is also possible.

Three cable entries allow for a variety of cabling options including through wiring.

Positive forced disconnected contacts

The design assures that the contacts will not fail or be held in a normally closed position, due to failure of the spring mechanism or the welding/sticking of the contacts.

Protection from unauthorised or incidental access

To avoid unauthorised operation the JSNY5 switch is manufactured using multicoding to GS-ET 15. The switch cannot be defeated by screwdrivers, magnets or any other mechanism.

Safety level

The positive forced disconnect contacts gives a high safety level. By combining the JSNY 5 with one of our suitable safety

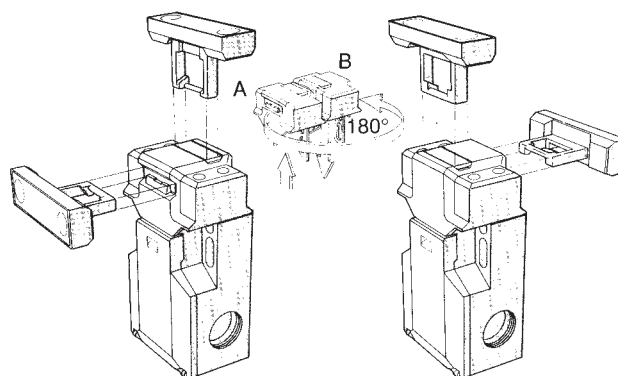

After opening the snap-on cover, the head portion can be removed (version A), after turning the head through 180° (version B) it can be replaced onto the body of the switch and be locked into position by closing the snap-on cover. This ensures 4 actuating positions are possible.

relays as for example from the RT-series, the safety PLC Pluto or Vital (Tina) the requirements for both hatch and gate switch supervision can be fulfilled. To obtain the same level of safety as Eden, two switches per gate are required.

Regulations and Standards

The JSNY5 is designed and approved in accordance with appropriate directives and standards. See technical data

Technical data – JSNY5	
Manufacturer	ABB AB/Jokab Safety, Sweden
Article number/ Ordering data: JSNY5A holding force 10 N JSNY5B holding force 30 N	2TLA020022R0000 2TLA020022R0100
Colour	Black and yellow label
Enclosure/Cover	PA 6 (UL94-VO)
Actuator	Steel
Min. opening radius for actuator on a hatch	150 mm
Ambient operating temperature	-30°C to +80°C
Contacts (actuator key inserted)	2 NC + 1NO (NC are direct opening action)
Mechanical life	1 Million switch operations
Max switching frequency	30/min
Fixing	body 2 x M5, actuator 2 x M5
Cable entry	2 x M20 x 1,5
Weight	approx. 0.13 kg
Degree of protection	IP65 IEC 60529 / DIN VDE 0470 T1

Rated insulation voltage	400 V AC
Rated operational current	5A
Utilisation category	AC-15/DC-13
Short-circuit protection	Fuse 6A Slow acting, 16A quick acting
CSA	5A 300V AC B300 (same polarity)
B_{10d}	JSNY 5A: 2,00×10 ⁶ JSNY 5B: 2,00×10 ⁶
Conformity	2006/42/EG EN ISO 12100 1/2, EN 954-1, EN 60204-1, EN ISO 13849-1, EN 1088, GS-ET 15

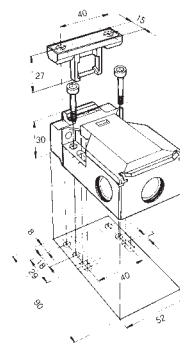

Assembly - JSNY5

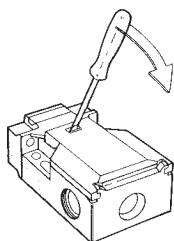

Easy accessibility for wiring

The snap-on cover is released by a screwdriver and can be opened to an angle of 135° providing easy access to the wiring terminals. Should the snap-on cover not provide adequate security, a retaining screw can be used.

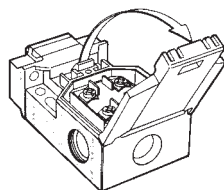

Protected contact block

A transparent cover protects the contact block from external elements during the installation and wiring process.

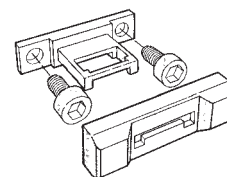

Prevention of actuator dismantling

A cover plate with a one-way snap-fit which seals the mounting screws prevents unauthorised dismantling of the actuator assembly. The cover plate **must** be mounted to prevent overtravel of the switching mechanism.

Contact Description - JSNY5

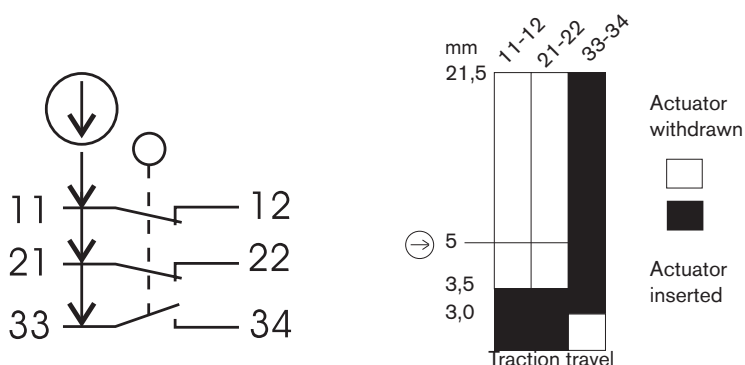

Overlapping contact 33 - 34.

The overlapping contact 33 -34 enables operational status indication of eg. incorrect adjustment of switch before the positive forced disconnect NC contacts open.

Note!

The switch must not be used as an end stop!

Accessories and spare parts

- Standard actuator
- Flexible key for smaller opening radius
- Cable gland
- Snap-on cover
- Tina 2A with M20 connection for a dynamic loop
- Tina 2B with cable connection
- Tina 3A with M12 and M20 connections for a dynamic loop

Magnetic Switch

JSNY7



Approvals:



Application:

Gates
Hatches
Position control

Features

Small size
IP 67

Switch operation description

The magnetic switch is designed to operate in dirty industrial environments and is certified to the highest level of safety regulation when working together with a suitable ABB Jokab Safety safety relay or Safety-PLC Pluto. The magnetic switch is small and resistant to both dirt and water, and has no dust collecting cavities making it useful in environments where hygiene is paramount. The small size of the switch makes it easy to position and hide on gates and hatches.

The magnetic switch has a long working life since no mechanical contact is made during operation.

Contacts

The magnetic switch has one closing and one opening contact. Both contacts have to be monitored. The contacts may be monitored by either the RT9 safety relay or other suitable relays in the new RT-series, i.e. RT6, RT9 or Safety PLC Pluto.

Protection from unauthorised or incidental access

To avoid unauthorised operation of the JSNY7 switch it is only possible to actuate the JSNY7R with the coded magnet, JSNY7M. Other magnets, screwdrivers and tools have no effect on the switch contacts.

Safety level

The JSNY7 is approved to the highest level of safety regulations, PL e according to EN ISO 13849-1 together with safety relay in the RT-series or Pluto PLC.

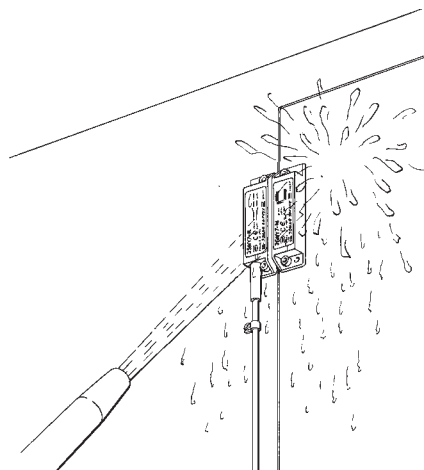

JSNY7 is resistant to both dirt and water.

Regulations and Standards

The JSNY7 is designed and approved in accordance with appropriate directives and standards. See technical data.

Technical data – JSNY7	
Manufacturer	ABB AB/Jokab Safety, Sweden
Article number/ordering data	JSNY7R-3 Magnetic switch 3 m cable 2TLA020023R0000 JSNY7R-6 Magnetic switch 6 m cable 2TLA020023R0100 JSNY7R-10 Magnetic switch 10 m cable 2TLA020023R0200 JSNY7M Magnetic switch 2TLA020024R0000
Colour	Black
Enclosure/Cover	PA 6 (UL94-VO)
Supply voltage max	30 VDC
Switch current max	100 mA
Max switching frequency	1 Hz
Mechanical life	3 x 10 ⁸ switch operations, depending on load
Operating temperature range	-5°C to +70°C (moveable) -20°C to +70°C (fixed)
Connection	Cable ø4.5, 4x0.25 mm ² , 3 meter ; PVC (other lengths upon request)
Switching point	Min. switch-on point 5 mm Max. switch-off point 14 mm
Weight	Coded magnet: 32 g Sensor with 3m cable: 133 g
Protection class	IP67

B_{10d}	JSNY 7R-3: 3,00×10 ⁷ JSNY 7R-6: 3,00×10 ⁷ JSNY 7R-10: 3,00×10 ⁷
Conformity	2006/42/EG EN ISO 12100 1/2, EN 954-1, EN 60204-1, EN ISO 13849-1, EN 1088, GS-ET 15

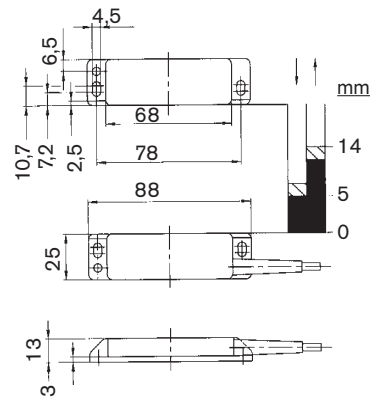

Electrical connection
Two-channel switching, high safety level.

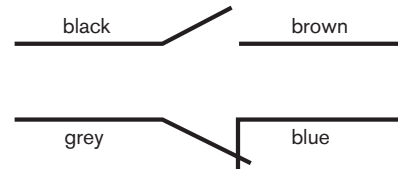

Electrical connection description - JSNY7

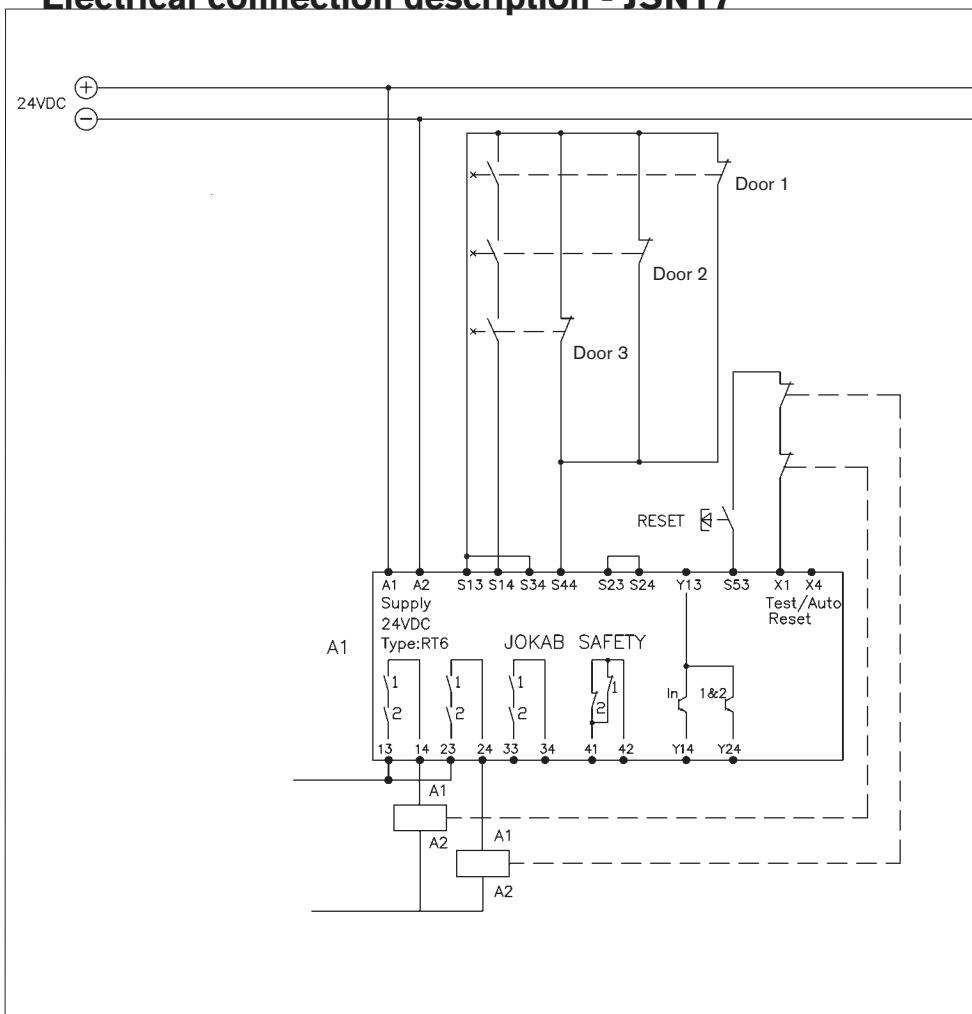

Electrical Connection example

Three JSNY7 connected to RT6 safety relay.

NOTE!

Safety components drawn in released position.

NOTE!

This solution with 3 magnetic switches only complies with category 3 as per EN 954-1/EN ISO 13849-1.

To reach highest level of safety only one magnetic switch should be connected to the safety relay.

Safety Interlock Switch

JSNY8

Approvals:



Application:

Gates
Hatches

Features:

Robust design
Universal installation
2 NC + 2 NC outputs
1000 N actuator holding force

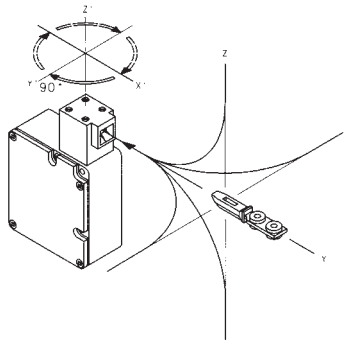

Description

The JSNY8 Safety Interlock Switch, in conjunction with the machine control system, enables gates/movable guards etc to be locked in their protective positions, thus preventing access to machinery until dangerous operations have ceased.

Applications include:

- processes which cannot be interrupted, such as welding.
- machinery with a long stopping procedure, such as paper machinery that requires a long braking operation.
- prevention of unauthorised access to a particular area.

The JSNY8 has 2 NC + 2 NC positive force disconnection contacts. The first pair closes when the actuator key is pushed into the head. The other pair closes when the locking mechanism is in the locked position. The head can be set in four positions, thus providing the safety device with four different operating positions. These are selected by twisting the head as shown in the diagram above. The leading edges of the actuator key are reinforced and bevelled in order to guide it properly into the hole. The JSNY8 is encased in a robust metal housing (IP67) providing a high level of protection to the internal operating components.

Two versions

The JSNY8 is available in two basic versions, either with a spring lock or a magnetic lock.

In the spring lock (JSNY8S) version, the locking mechanism moves into the locked position directly when the door is closed and the actuator key is pushed into the lock. The actuator key can only be released and the gate opened by supplying operational voltage to the solenoid (E1-E2).

The JSNY8S also has an emergency 'unlocking' facility to enable the actuator key to be released without the energisation of the solenoid (E1-E2).

In the magnetic lock (JSNY8M) version, the locking mechanism is only in the locked position when the solenoid (E1-E2) is supplied with operating voltage. Release of the actuator key is only possible when the operating voltage is removed from the solenoid (E1-E2).

Optional features

The following optional features are available:

- actuator to operate at smaller radius.
- customer specific applications.

Tamper-proof

The JSNY8 is tamper-proof. The safety device cannot be manipulated by screwdrivers, magnets or other tools.

Safety level

The JSNY8 has double forced disconnection contacts to the actuator key and the locking mechanism. The actuator key has a triple coding design. To achieve maximum safety level in the connection to the machine's control system, it is recommended that the JSNY8 is monitored by an appropriate ABB Jokab Safety safety relay, Pluto safety-PLC or Vital. To obtain the same level of safety as Eden, two switches per gate are required.

JSNY8S

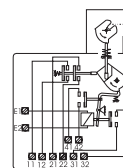

JSNY8M

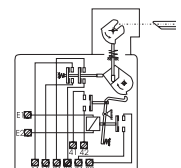

Regulations and Standards

The JSNY8 is designed and approved in accordance with appropriate directives and standards. See technical data.

Safety Interlock switch

JSNY9

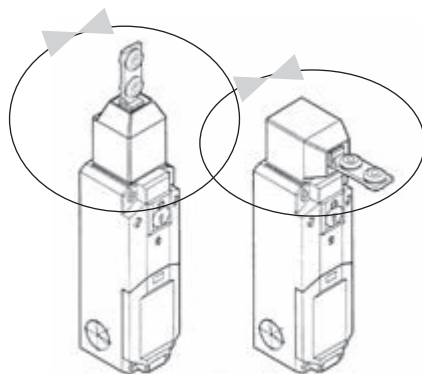

The control unit offers eight operating positions that provide the actuator with eight different input options.

Approvals:



Application:

Gates
Hatches

Features:

Compact and robust
Universal installation
2 X (1NO+1NC)
Actuator holding force
1500 N
Eight head configurations
LED status indication
(optional)

Description

The JSNY9 is used for locking a gate/hatch, to prevent access to machinery, until hazardous operations have ceased.

Applications include:

- processes which cannot be interrupted, e.g. welding.
- machinery with a long stopping time, e.g. paper machinery which requires a long braking operation.
- prevention of unauthorised access to a particular area.

The JSNY9 is equipped with a 2 x (1NO + 1 NC) contact configuration, the first pair of contacts changeover when the key is inserted. The second pair of contacts changeover when the locking mechanism is in the locked position.

The JSNY9 switch is encased in a robust plastic housing and can be mounted either horizontally or vertically. The advanced design of the head provides eight possible key insertion options, this is achieved by mounting the head either vertically or horizontally on the base unit, as shown in the diagram. The location for the actuator key is reinforced and bevelled to ensure a smooth operation.

Two versions

The JSNY9 switch is available in two basic versions, either with a spring lock or an electro-magnetic locking mechanism.

The JSNY9S (spring lock) switch operates immediately when the gate/hatch is closed, i.e. when the key actuator is inserted into the locking mechanism. The gate/hatch can be opened and the actuator key released only by supplying the operational voltage to the solenoid connections (E1 E2). The JSNY9S also has a manual emergency unlocking facility to enable authorised release of the actuator key.

In the JSNY9M (magnetic lock) version, the mechanism is only locked when the gate/hatch is closed i.e. the actuator key inserted and the solenoid (E1 E2) supplied with the operating voltage. The gate/hatch can only be opened when this operating voltage is removed.

Optional features

The following optional features are available:

- LED display, indicating the status of the actuator key, locking mechanism and contacts.
- Actuator to operate at smaller radii.
- Customer specific applications.

Protection from unauthorised access

The JSNY9 is designed to protect against unauthorised access; screwdrivers, magnets or similar tools cannot operate the safety switch.

Safety level

In order to achieve a high safety level, the JSNY9 switch is equipped with dual sets of contacts operated with a coded actuator key. In order to meet the required installation safety level it is recommended that the JSNY9 safety switch is monitored by an appropriate ABB Jokab Safety safety relay. To obtain the same level of safety as Eden, two switches per gate are required.

Regulations and Standards

The JSNY9 is designed and approved in accordance with appropriate directives and standards. See technical data.

Technical data – JSNY9	
Manufacturer	ABB AB/Jokab Safety, Sweden
Article number/Ordering data: JSNY9S 24V AC/DC JSNY9M 24V AC/DC	2TLA020036R4400 2TLA020036R4500
Colour	Black
Enclosure/Cover	Polyamid PA6
Actuator	Steel & plastic (PA6)
Min. key operating radius	400 mm (smaller radius available on request)
Actuator holding force	1500 N
Operating temperature	- 25° C to + 70° C
Contacts actuator in Locking mechanism in locked position	1 NO + 1 NC 1 NO + 1 NC (NC are direct opening action)
Mechanical life	1 million switch operations
Installation fixing	4 x M5
Cable entry	3 x M20 x 1.5
Weight	approx. 300 g
Enclosure Class	IP67
Operating voltage	24 V AC/DC
Isolation voltage	250 V
Thermal Current	2.5 A

Utilisation category	AC 15 230V / 4A
Short-circuit protection	Fuse 6 A slow acting
Power consumption	1.1 VA (56 VA during 0.2s)
B_{10d}	JSNY 9M: 2,00E+06 JSNY 9S: 2,00E+06
Conformity	2006/42/EG EN ISO 12100 1/2, EN 954-1, EN 60204-1, EN ISO 13849-1, EN 1088, GS-ET 19, EN 60947-5-1

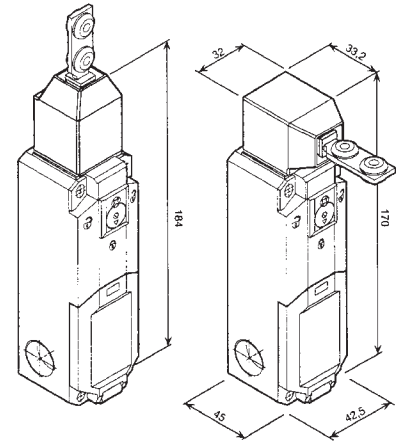

NB.

The safety switch must not be used as an end stop!

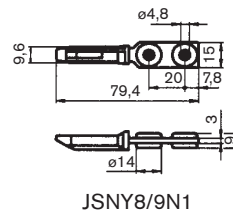
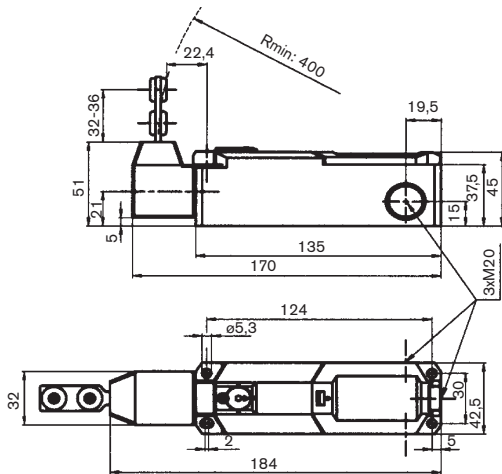

JSNY8/9N1

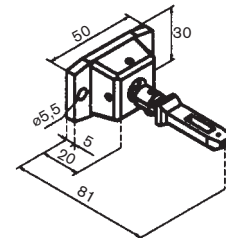

JSNY8/9N2
Rmin: 150 mm

Contact description - JSNY9 S/M

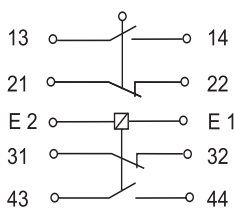

JSNY9S
Actuator inserted
Locked position
(E1-E2 unpowered)

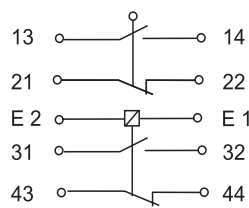

JSNY9M
Actuator inserted
Unlocked position
(E1-E2 unpowered)

JSNY9SLA/MLA
See separate data sheet
for switches with LED
indication.

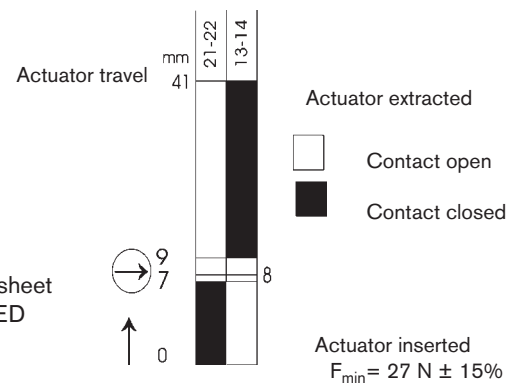

Magnetic lock

Magne

Approval:

TÜV Nord 

Application:

Electrical locking of doors and hatches to production applications that are sensitive to unintentional/unnecessary interruptions.

For safety supervision the Magne 2 has an integrated Eden.

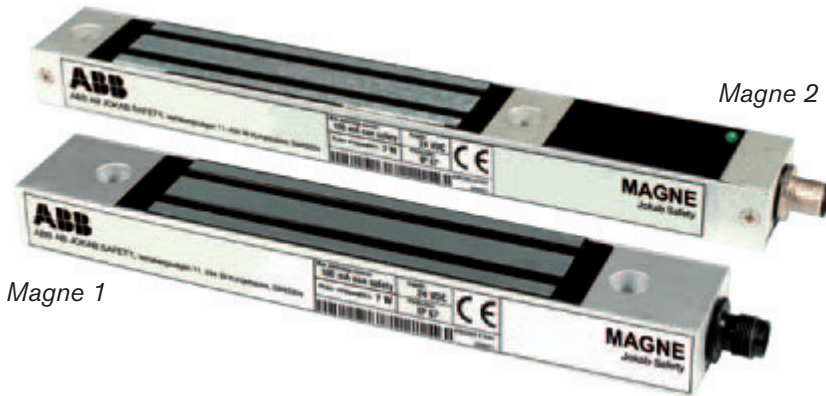

Magne 2

Magne 1

Features:

No moving parts

Strong Magnetic holding force: 1500N

Can stand and operate in harsh environments

Locked/unlocked indication
Possible to connect in series with Eden sensors

No current peaks on activation

Magne 2 in combination with a handle profile provides a complete door solution

Magnetic lock with indication

Magne is a magnetic lock that is designed for industrial applications and that can withstand harsh environments. As it is designed with no moving parts, it is durable and long lasting. Magne, with its electro-magnet, keeps a door locked with a holding force up to 1,500 N and also magnetic material does not attach to the magnetic surface when the power is off.

Use of M12 connectors makes it easy to connect several Magne units and Eden sensors in series enabling control and monitoring by either a Pluto safety PLC or a Vital safety controller. Via the connection cable it is also possible to obtain an indication signal informing if the Magne unit is locked or not.

Accessories:

- Mounting kit for conventional door, with fitting and screws for assembly on ABB Jokab Safety Quick-Guard fencing system (5-15 mm door gap)
- Plastic handle
- Handle profile for mounting on a hinged door with ABB Jokab Safety's Quick-Guard fencing system (5-15 mm door gap).



Magne is easy to assemble, adjust and dismantle in and out of the T-slot of the Quick-Guard fencing system.

Models and accessories - Magne

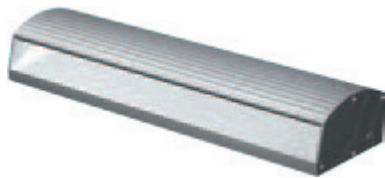

Handle profile that hides Magne completely when the door is closed.

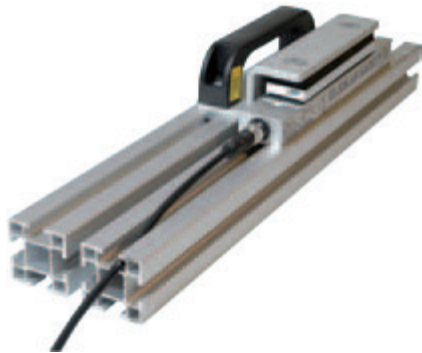

Magne 1A with installation kit (JSM D21B) and handle (incl. screw) fitted on profile.



Magne 2A with installation kit (JSM D23) for sliding door fitted on profile.



Magne 2A with installation kit (JSM D21B, JSM D24) and handle (incl. screw) fitted on profile.

Models and ordering data

Magne 1A	2TLA042022R0000	Process lock, Incl. anchor plate
Magne 2A	2TLA042022R1000	Process lock with built-in Eden, incl. anchor plate
Magne 1B	2TLA042022R0100	Process lock incl. anchor plate with built-in permanent magnet (30 N)
Magne 2B	2TLA042022R1200	Process lock incl. anchor plate with built-in Eden and built-in permanent magnet (30 N)
Magne 2Ax	2TLA042022R1300	Process lock with built-in Eden and 5-pin M12 connector for Urax, incl. anchor plate
Magne 2Bx	2TLA042022R1400	Process lock with built-in Eden and 5-pin M12 connector for Urax, incl. anchor plate with built-in permanent magnet (30 N)
Accessories		
JSM D21B	2TLA042023R0500	Assembly kit for anchor plate
	2TLA042023R0100	Handle profile for Magne
JSM D23	2TLA042023R0200	Fixture for sliding door
JSM D24	2TLA042023R0300	Assembly kit for Eva
	2TLA042023R0400	Anchor plate with permanent magnet
	2TLA042023R1000	Handle for JSM D21B

Technical data – Magne	
Manufacturer	ABB AB/Jokab Safety, Sweden
Safety level IEC/EN 61508-1...7 EN 62061 EN ISO 13849-1	SIL3 SIL3 Kat. 4/PL e
PFH_D	4,50×10 ⁻⁹
Power supply	Magnet: 24 VDC + 15% -20% Eden: 17–27 VDC, ripple max 10%
Power consumption	Magnet: 7 W (300 mA at 24VDC) Eden: 45–55 mA (see data for Eden)
Operating temp. range	-20°C to +50°C
Protection class	IP67
Weight	Magne 1: 610 g Magne 2: 700 g Anchor: 290 g
Material	Anchor plate and magnet: steel Housing: Aluminium
Holding force	24 VDC: Min 1500 N 0 VDC: 0 N (Magne 1A/2A) 0 VDC: 30 N (Magne 1B/2B)
Contacts	Reed sensor (not safe)
Switch current max	100 mA
Mechanical life	>10 ⁷ switch operations
Connector	M12 5-pole male connector (Magne 1A, 1B, 2Ax, 2Bx) M12 8-pole male connector (Magne 2A, 2B)
Connections	Magne 1A/B: (1) Brown: Locking, +24 VDC (2) White: Sensor supply (3) Blue: 0 VDC (4) Black: NO-contact (5) Grey: NC-contact Magne 2A/B: (1) White: Dynamic signal input (2) Brown: +24V DC (3) Green: Locking, +24V DC (4) Yellow: Locking, 0V DC (5) Grey: Info closed (max 10 mA) (6) Pink: Dynamic signal output (7) Blue: 0V DC (8) Red: Info locked (max 100 mA) Magne 2Ax/Bx: (1) Brown: +24 VDC (2) White: Dynamic signal input (3) Blue: 0 VDC (4) Black: Dynamic signal output (5) Grey: Locking
Conformity	2006/42/EG EN ISO 12100-1/2:2003, EN ISO 13849-1:2008, EN 62061:2005, EN 1088
Certifications	TÜV Nord 

Dimensions - Magne

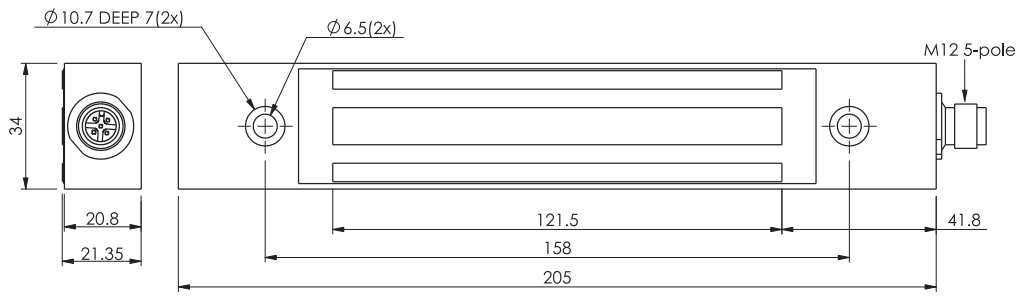

Dimensions Magne 1A/B

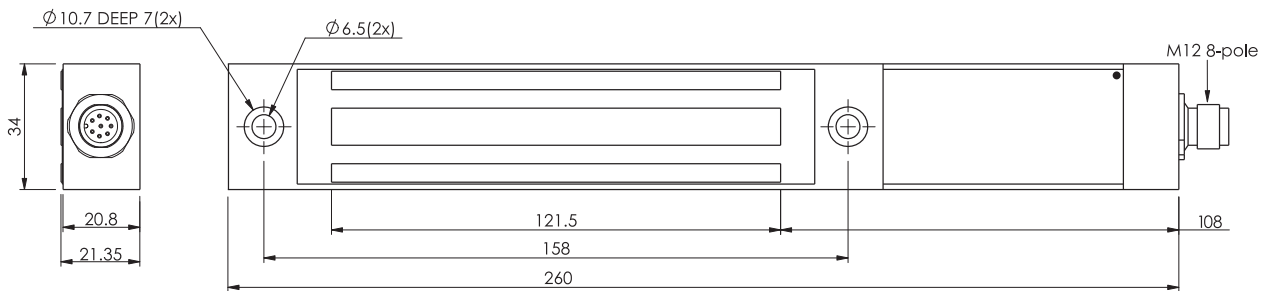

Dimensions Magne 2A/B

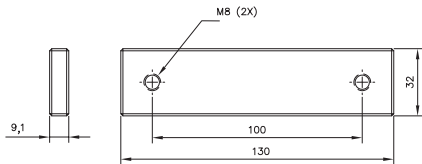

Dimensions Anchor plate
(without permanent magnet)

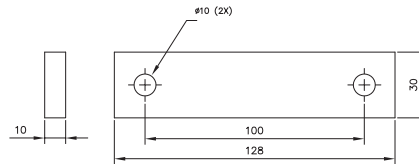

Dimensions - cell rubber

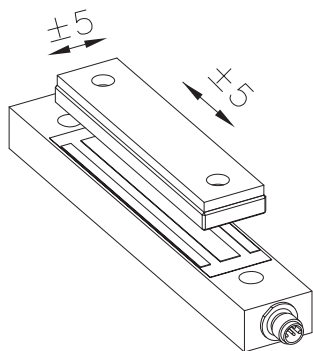

Installation tolerance (general)

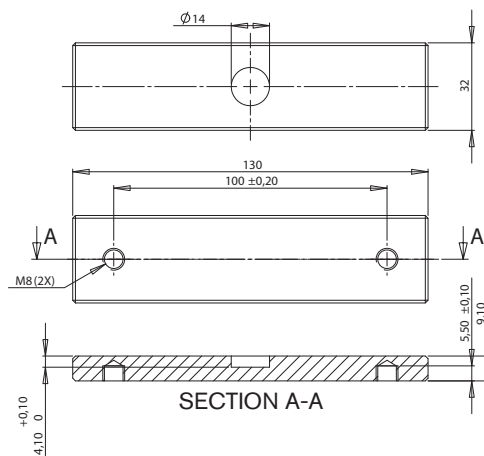

Dimensions Anchor plate
(with permanent magnet)

Holding force - Magne 1 and 2

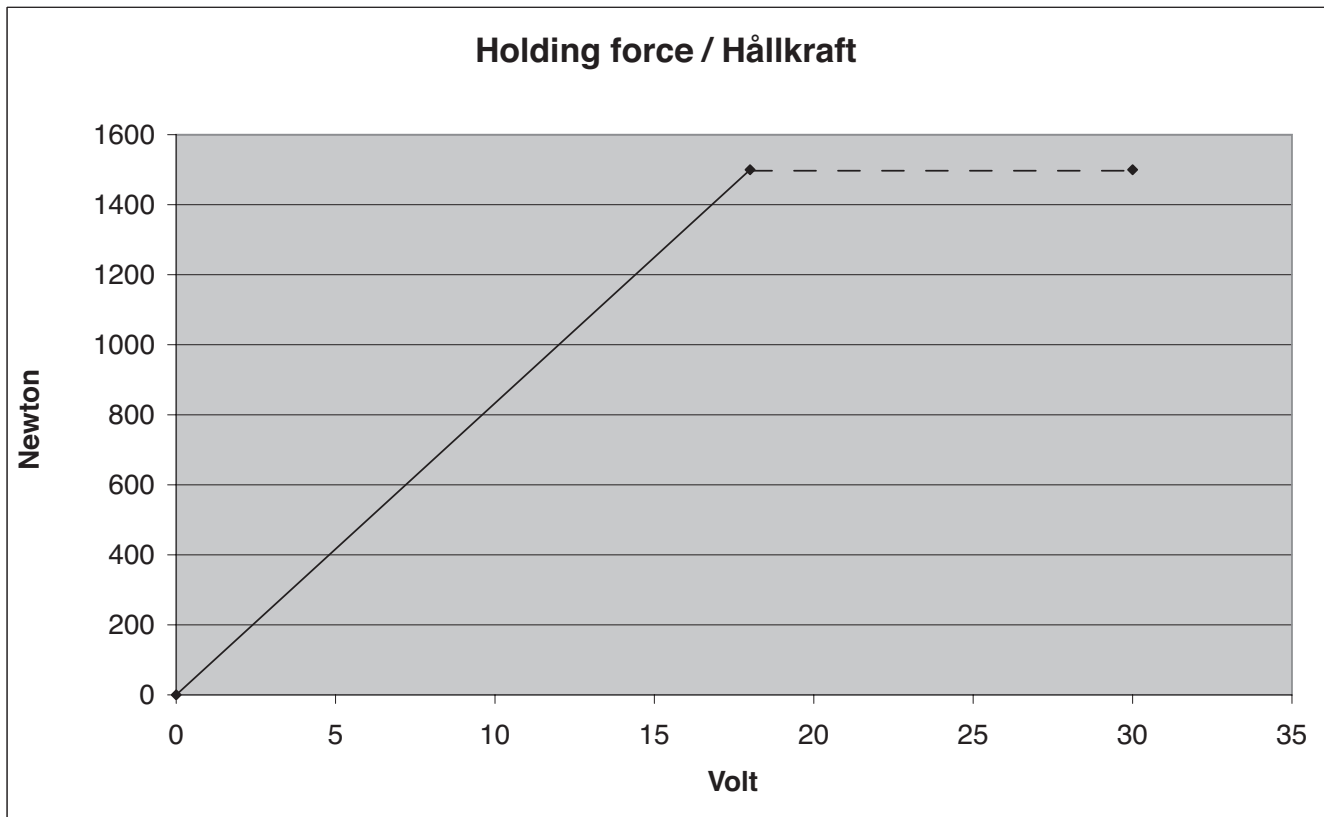

Connection example - Magne 1 and 2

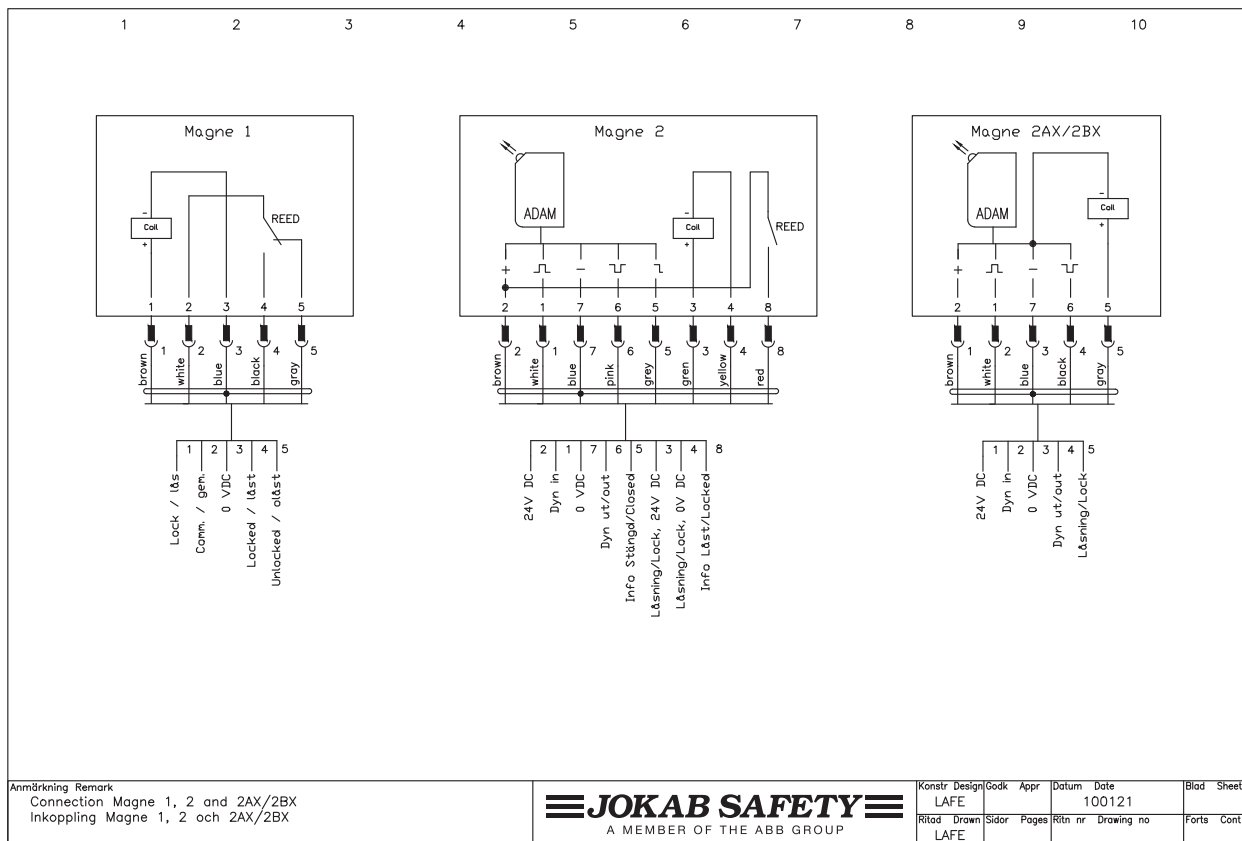

Connection example - Magne 1 in series

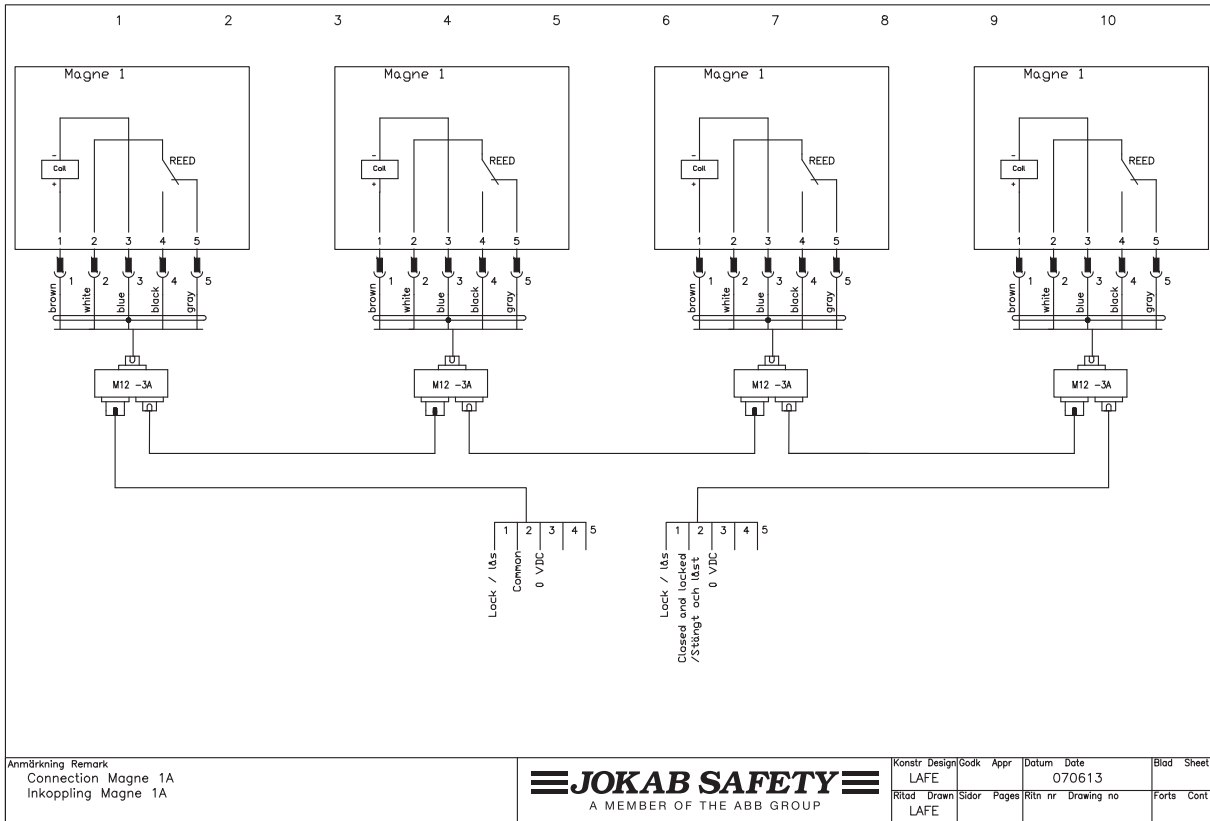

Connection example - Magne 2 in series

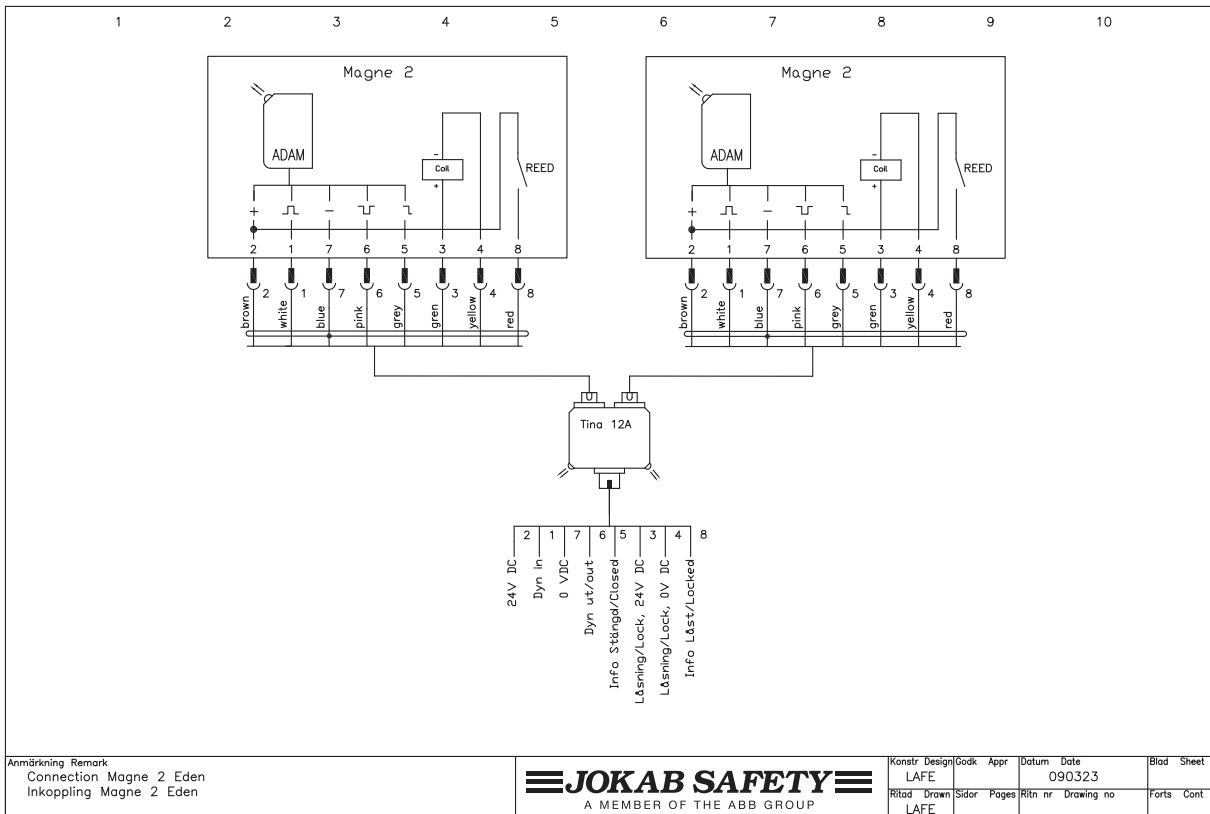

Process lock

Dalton

Use:

Doors and hatches

Advantages:

- Small and robust
- Integrated with Eden
- Flexible installation
- High enclosure classification – IP 67
- Withstands severe environments
- Low current consumption
- Status information with LED on the lock housing and in the cable connection.



Dalton – the intelligent process lock

Dalton is a locking unit that is intended for use in preventing unnecessary process stoppages, i.e. it is not a safety lock. It can be used either as a free-standing lock or integrated with Eden as a safety sensor. In the unlocked state the door is held closed by a ball catch and in locked state the balls are mechanically blocked so the lock tongue can not be pulled out. If necessary, the holding force of the ball catch can be adjusted. The device only allows to lock when the ball latch is centred around the lock tongue, and when Eva is with Adam (depending on version). When an input is supplied with voltage, the ball catch is locked.

Dalton is easily connected with an M12 connector. The Tina junction block can be used for distribution of both the safety and locking functions. The Dalton status is indicated by LEDs and can also be read by a PLC via the information output.

Dalton has a modular structure

The Dalton process lock has a modular structure and can be combined in different ways depending on position, installation and function. You choose the lock housing, lock tongue and fixing plate yourself to create a complete Dalton.

Installation

Dalton offers many different installation possibilities as the lock tongue may enter the ball catch from three directions. In order to ensure that Dalton works without any problems, the ball catch must be resting, i.e. the balls not pressed in by the lock tongue when the door is in closed position. Dalton's brackets are therefore made to ensure easy adjustment of the lock tongue and ball latch positions.

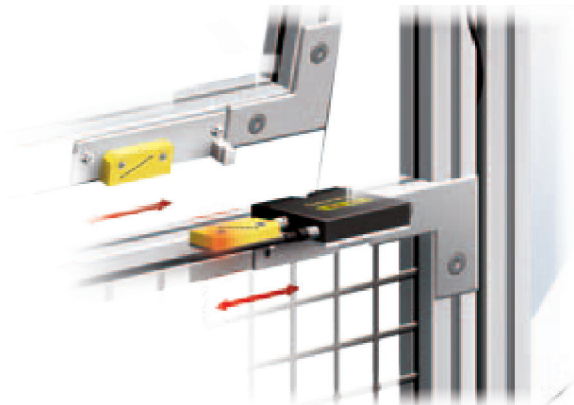

Dalton is easy to install, adjust and dismantle in the Quick-Guard fence system's T-slots.

Modular structure - Dalton

1. Choose Dalton lock housing according to your preferences:

- Dalton M11/M31 If you only need to be able to lock your door/hatch (8-pin/5-pin M12)
- Dalton M12 If you want to lock your door/hatch and also have the interlocking switch Eden installed with one cable, common for both Dalton and Eden.
- Dalton L00 If you only need to use Dalton to keep the door fixed and closed



Dalton M11
with 8-pin male contact



Dalton M12
with 8-pin male contact,
5 pin female contact for
Adam



Dalton M31
with 5-pin male contact



Dalton L00
as ball latch, no electrical
functions.

2. Choose a lock tongue depending on how the door/hatch is closed.

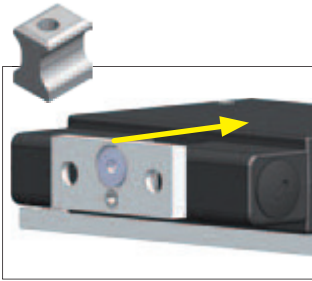

Lock tongue A
Selected when the door
closes to the Dalton front

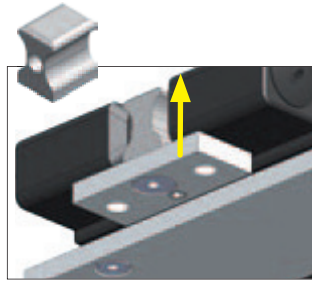

Lock tongue B
Selected when the door closes to Dalton's upper or lower side

For Dalton L00 both lock tongues can be used regardless of the operating direction

3. Choose a fixing kit that fits your installation.

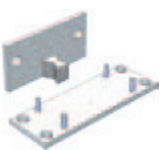

Fixing kit 1
for Dalton and
lock tongue



Fixing kit 2
for Dalton and Adam and
also for lock tongue and
Eve

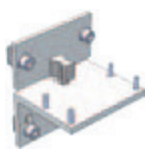

Fixing kit 3
for Dalton
adapted to
ABB Jokab
Safety fencing
system



Fixing kit 4
for Dalton and Eden
adapted to ABB
Jokab Safety fencing
system



Fixing kit 5
for Dalton, small
bracket for lock
tongue



Fixing kit 6
for Dalton and
Eden, small bracket
for lock tongue

Read the manual for further information about correct installation of Dalton

Accessories - Dalton

Tina 12A junction block











Tina 12A can be used to connect two Daltons with Edens with one cable to the apparatus enclosure. The summed information that indicates the states of both the Dalton and Eden also goes to the apparatus enclosure.

Transfer cables

A transfer cable can be used when the Dalton's 8-pole connector is to be connected to the 5-pole M12 connector of Tina 4A or Tina 8A. Note that the info-signals from Dalton and Adam cannot be used.

Technical data – Dalton	
Manufacturer	ABB AB/Jokab Safety, Sweden
Artikelnummer/ beställningsdata:	
Dalton L00 – Only ball latch, no electrical functions	2TLA020038R3000
Dalton M11 – 8-pin male plug	2TLA020038R3100
Dalton M12 – 8-pin male plug, 5-pin female to Adam	2TLA020038R3200
Dalton M31 – 5-pin male plug	2TLA020038R3300
Lock tongue A – Lock tongue for front entry	2TLA020039R0800
Lock tongue B – Lock tongue for top and bottom entry	2TLA020039R1000
Fixing kit 1 – Fixing plates for Dalton and lock tongue	2TLA020039R0000
Fixing kit 2 – Fixing plates for Dalton and Adam and also for lock tongue and Eve	2TLA020039R0100
Fixing kit 3 – Fixing plates for Dalton adapted to ABB Jokab Safety fencing system	2TLA020039R0200
Fixing kit 4 – Fixing plates for Dalton and Eden adapted to ABB Jokab Safety fencing system	2TLA020039R0300
Fixing kit 5 – Fixing plate for Dalton, small bracket for lock tongue	2TLA020039R0400
Fixing kit 6 – Fixing plate for Dalton and Eden, small bracket for lock tongue	2TLA020039R0500
Accessories	
DA 1 – Spacer 2.5 mm for Adam and Eva.	2TLA020053R0000
M12-CT0214 – Transfer cable 0.2 m M12 5-pole male plug and 8-pole female plug	2TLA020060R0100
Tina 12A – Distribution block for two Dalton Edens with 8-pole cables	2TLA020054R1800
Safety level	
For interlocking switch Eden. Not valid for locking function. IEC/EN 61508-1...7	SIL3
EN 62061	SIL3
EN ISO 13849-1	Kat. 4/PL e
PFH_D	
For interlocking switch Eden. Not valid for locking function.	4,50×10 ⁻⁹
Locking function	M - Locked when energised L - Only ball latch
Colour	Black
Operating voltage	24 VDC +25/-20%
Current consumption	
Unlocked	40 mA
Locked	130 mA
Lock input	5 mA
Information output	Max. 10 mA
Eden	See the data for Adam M12
Operating temp. range	-10°C to +55°C
Enclosure classification	IP67
Holding force	
Unlocked	25-100 N
Locked	2000 N

Material	Ball catch, securing plate Enclosure Lock tongue, securing plate	Anodised aluminium Anodised aluminium Stainless steel
Chemical resistance	Stainless steel Anodised aluminium	Good resistance against most acids except hydrochloric acid and sulphuric acid. Very good resistance against corrosion, good resistance to most acids.
Connections		Connector to connect Dalton (varies depending on type) 8-pole male plug, M12 5-pole male plug, M12 Outlet for externally connected Adam female plug M12, 5-pole
Colour markings (pins)	Function	8-pole Colour 5-pole Colour
	Dynamic input signal, Adam +24 VDC	1 (White) 1 (Brown)
	Lock signal	2 (Brown) 4 (Black)
	Not used	3 (Green) 2 (White)
	Information Adam	4 (Yellow) 5 (Grey)
	Dynamic output signal, Adam 0 VDC	5 (Grey) 6 (Pink)
	Information Dalton	6 (Pink) 7 (Blue) 3 (Blue)
		7 (Blue) 8 (Red) 5 (Grey)
Warning	Dalton locks mechanically. If the lock is forced, the Dalton can be permanently damaged.	
Conformity	2006/42/EG EN ISO 12100-1:2003 EN ISO 12100-2:2003 EN ISO 60204-1 EN ISO 954-1 EN ISO 13849-1:2008	

LED indication – Dalton	
LED indication	Information function
	
	1 Locked
	0 Closed but unlocked
	0 Open
Alarm:	
	1Hz Lock has not entered the unlocked state
	1Hz Eden or ball catch not in position = open
	1Hz Open, locking not permitted
	1Hz Lock has not entered the locked state
	1Hz Undervoltage - locking not permitted
	1Hz Overvoltage
	1Hz Overtemperature (> 80°C)

Dimensions – Dalton

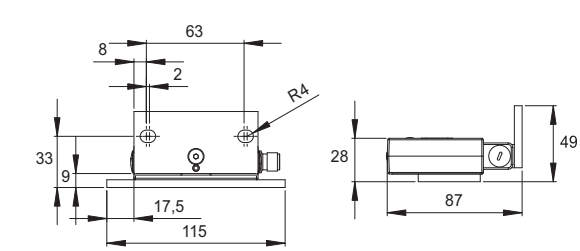

Bracket 1 with Dalton

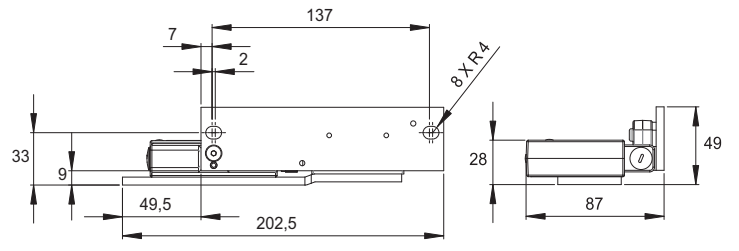

Bracket 2 with Dalton and Eden

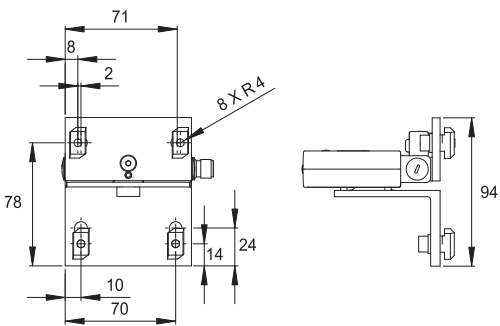
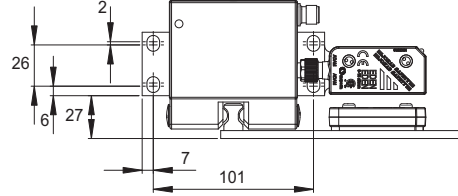
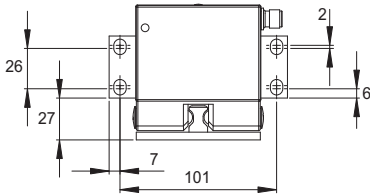

Bracket 3 with Dalton

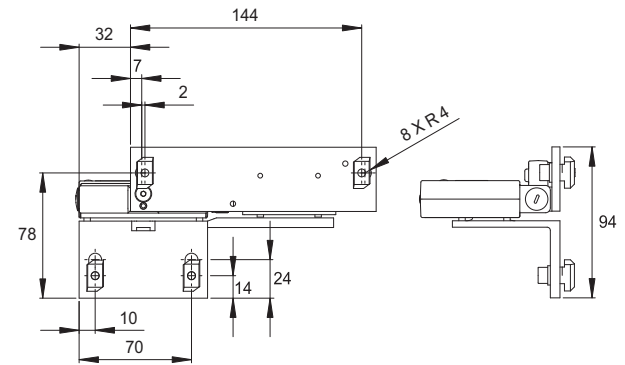

Bracket 4 with Dalton and Eden

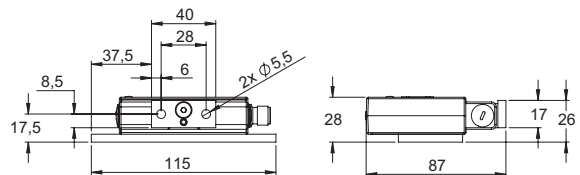
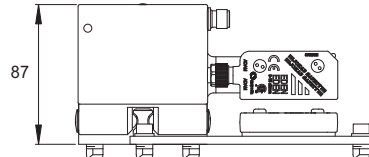
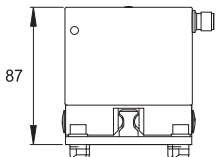

Bracket 5 with Dalton

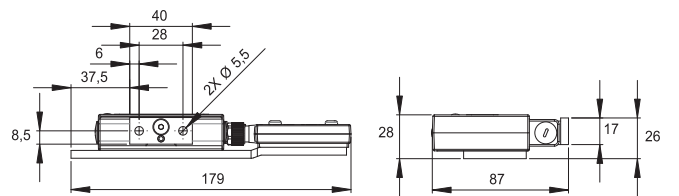

Bracket 6 with Dalton and Eden

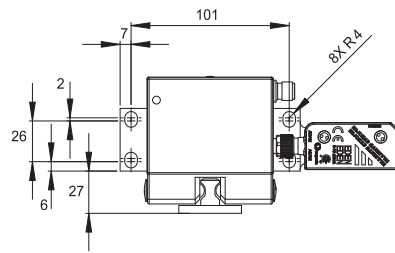
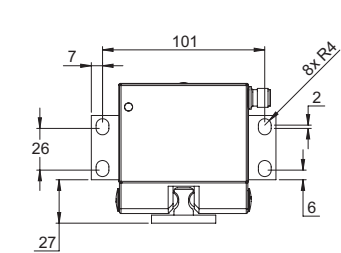

Connection example – Dalton M11, M31 and M12

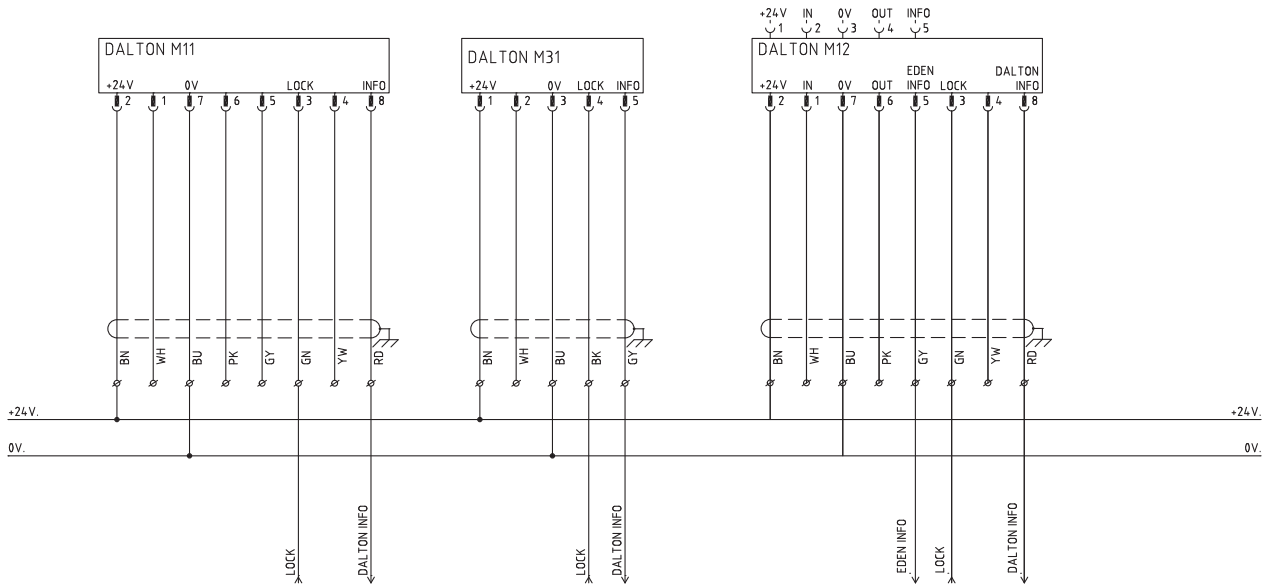

Connection example – Dalton M12 and Vital

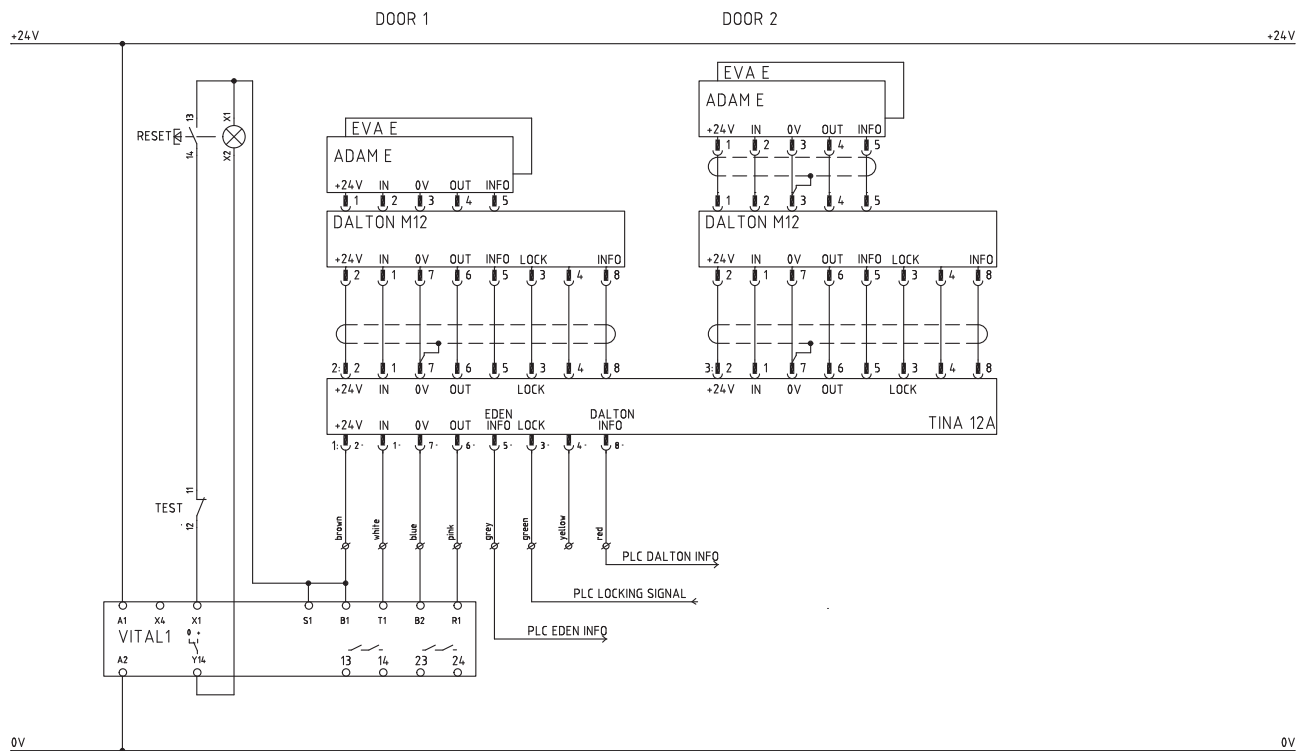

Connection example – Dalton M12 and Eden through Tina 4A

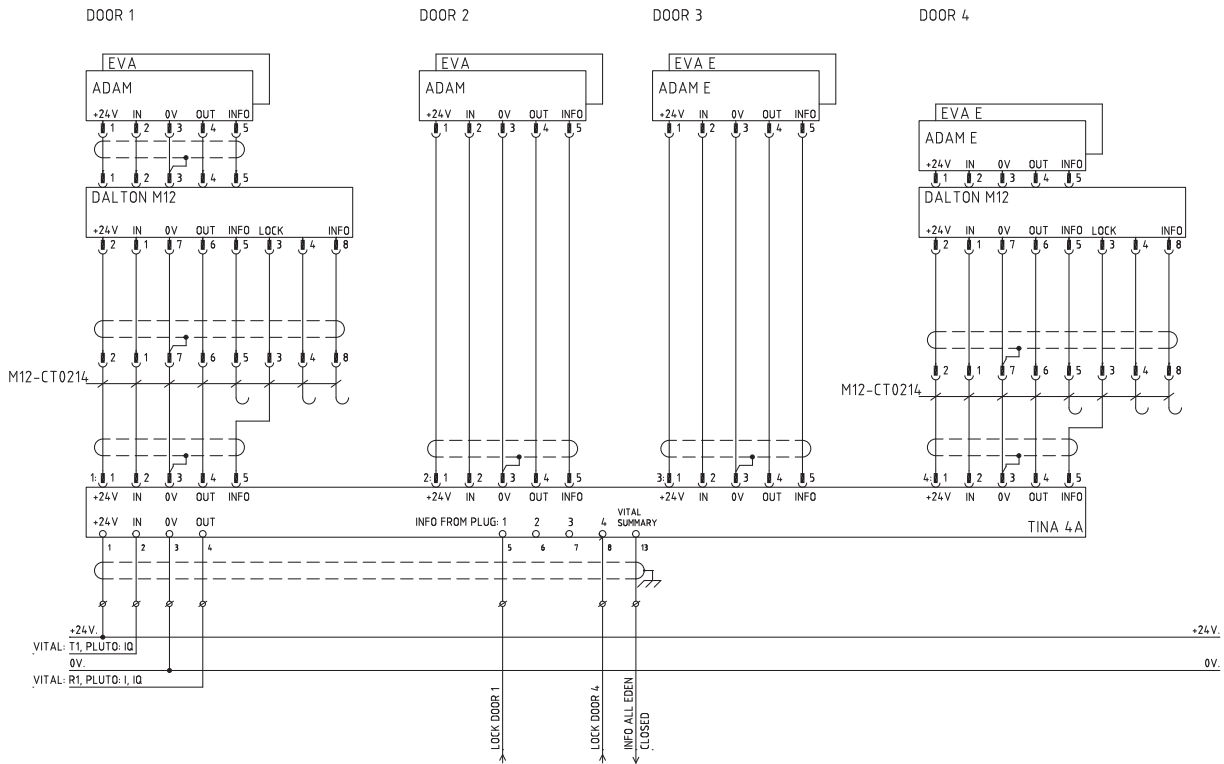

Connection example – Dalton M12 and Eden through Urax A1 (AS-i)

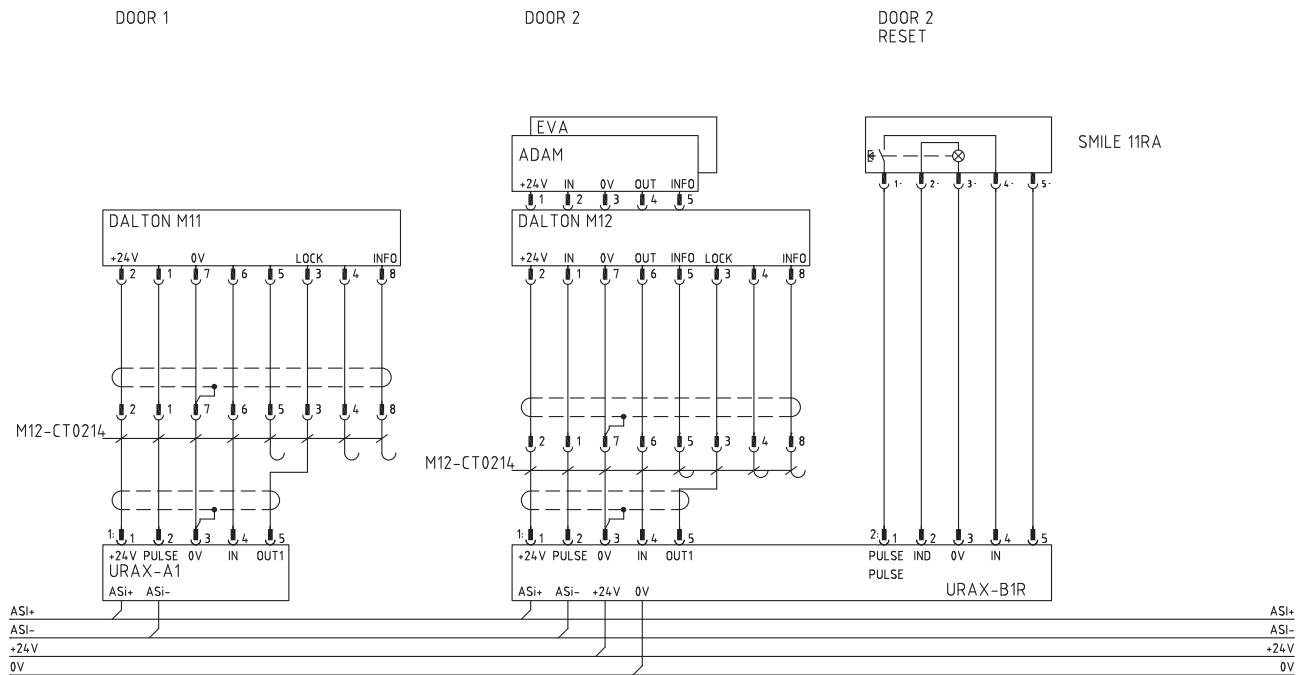

Safety and process lock

Knox

Approval:



Application:

Safe locking of door to a cell/line with long stopping time.

Prevents unintentional interrupts of processes

Advantages:

Double locking function as specified in PL e/cat. 4 (EN ISO 13849-1)

Withstands harsh environments

Status information with LEDs on the lock and at cable connection.

Controlled to locked and unlocked positions - position remains in the event of power failure.

Electronic connection only on the door frame

Robust design



Knox - Double safety lock as specified in PL e/cat. 4

Knox is a double lock that complies with the highest safety level (two lock cylinders with monitored positions) that can be used both as a safety and process lock. The locking function is electrically controlled and is bi-stable, i.e. it retains its position (unlocked/locked) in the event of a power failure. Dual signal for unlocking is safe at both short-circuits and cable breaks.

The handles operate as they would on a normal door but the exterior handle also have a reset function, why a separate reset button is not necessary and the interior handle that can be used for emergency opening also in locked state. The design and durability of the lock mean that it is ideal for harsh environments as the sensors are non-contact and the lock is manufactured of stainless steel. Knox is available in a number of adaptations such as left-hung door, right-hung door, inward and outward opening, with manual unlocking and for sliding door.



Knox is easy to assemble, adjust and dismantle in and out of the T-slot of the Quick-Guard fencing system.

Knox in 4 different states

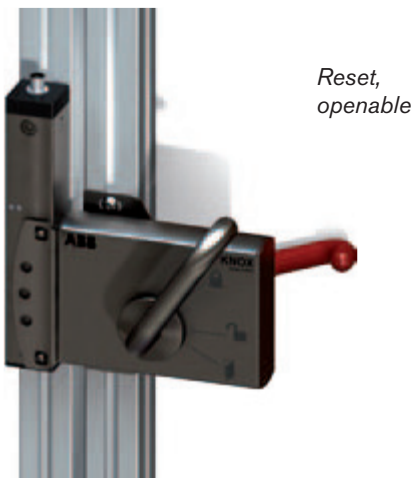
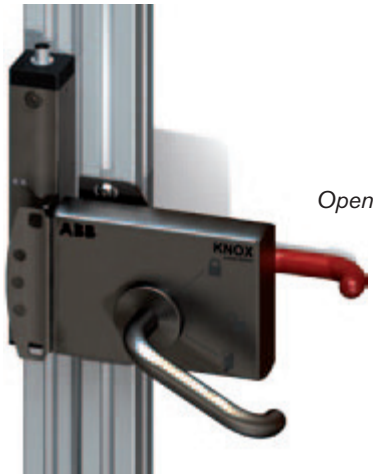

Models and ordering data	
Door part	
Knox 1A-R v2 2TLA020105R5000	Knox door part for outward-opening right-hung door
Knox 1A-L v2 2TLA020105R5100	Knox door part for outward-opening left-hung door
Knox 1B-R v2 2TLA020105R5200	Knox door part for inward-opening right-hung door
Knox 1B-L v2 2TLA020105R5300	Knox door part for inward-opening left-hung door
Knox 1AX-R v2 2TLA020105R5800	Knox door part for outward-opening right-hung door with the option for manual unlocking from the outside
Knox 1AX-L v2 2TLA020105R5900	Knox door part for outward-opening left-hung door with the option for manual unlocking from the outside
Knox 1F-R v2 2TLA020105R6000	Knox door part for sliding door that opens to the right. Incl. additional fastening fixtures for the frame.
Knox 1F-L v2 2TLA020105R6100	Knox door part for a sliding door that opens to the left. Incl. additional fastening fixtures for the frame.
Knox 1BX-R v2 2TLA020105R6200	Knox door part for inward-opening right-hung door with the option for manual unlocking from the outside
Knox 1BX-L v2 2TLA020105R6300	Knox door part for inward-opening left-hung door with the option for manual unlocking from the outside
Knox 1FX-R v2 2TLA020105R6400	Knox door part for sliding door that opens to the right with the option for manual unlocking from the outside. Incl. additional fastening fixtures for the frame.
Knox 1FX-L v2 2TLA020105R6500	Knox door part for sliding door that opens to the left with the option for manual unlocking from the outside. Incl. additional fastening fixtures for the frame.
Frame part	
Knox 2A v2 2TLA020105R2200	Standard Knox frame part 8-pin M12 contact, supplied for right-hung door. For instructions for turning, see the Knox manual
Knox 2X v2 2TLA020105R2300	Knox process lock, no duplicate unlocking signal, with 5-pin M12 contact
Accessories	
PC plate for Knox on mesh door 2TLA020106R0000	When mounting Knox on door with mesh the accessory PC plate for Knox is recommended. This is to avoid emergency opening from the outside.
Escutcheon plate for Knox (without emergency release handle) 2TLA020106R0600	When mounting Knox on a low door it is recommended to replace emergency release handle to prevent opening from the outside by reaching over.
Tina 12A 2TLA020054R1800	Distribution block for two Knox

Knox door part 1A-R and frame part 2A



Knox door part 1A-L and frame part 2A



Knox door part 1B-R and frame part 2A



Knox door part 1B-L and frame part 2A



Knox door part 1F-R and frame part 2A



Knox door part 1F-L and frame part 2A

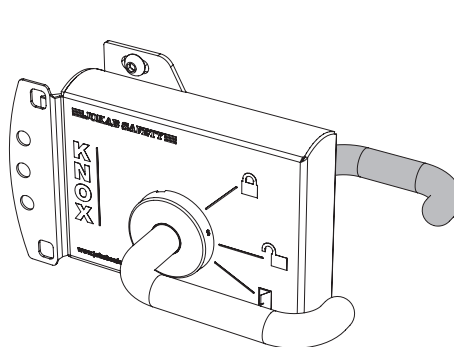

Door part Knox1

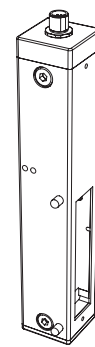

Frame part Knox2

Technical data – Knox																			
Make	ABB AB/Jokab Safety, Sweden																		
Safety level EN ISO 13849-1	Kat. 4/PL e																		
PFH_D	4,50 × 10 ⁻⁹																		
Lock function	S/M - unlocked and locked with voltage.																		
Operating voltage	24 VDC +/- 15%																		
Power consumption Electronics Lock/lock inverse Total max Information output	70 mA (in locked position) 135 mA (when locking/unlocking) 150 mA Max. 10 mA																		
Insulation class	IP65																		
Holding strength Unlocked Locked	5000 N (10,000 N ultimate breaking strength) 5000 N (10,000 N ultimate breaking strength)																		
Connection	Male plug M12, 8-pole																		
Connections Knox 2A Function +24 VDC Lock Lock inverse Information Locked Dynamic output signal 0 VDC Information reset	<table border="1"> <thead> <tr> <th>8-pole</th> <th>Colour</th> </tr> </thead> <tbody> <tr><td>1</td><td>(White)</td></tr> <tr><td>2</td><td>(Brown)</td></tr> <tr><td>3</td><td>(Green)</td></tr> <tr><td>4</td><td>(Yellow)</td></tr> <tr><td>5</td><td>(Grey)</td></tr> <tr><td>6</td><td>(Pink)</td></tr> <tr><td>7</td><td>(Blue)</td></tr> <tr><td>8</td><td>(Red)</td></tr> </tbody> </table>	8-pole	Colour	1	(White)	2	(Brown)	3	(Green)	4	(Yellow)	5	(Grey)	6	(Pink)	7	(Blue)	8	(Red)
8-pole	Colour																		
1	(White)																		
2	(Brown)																		
3	(Green)																		
4	(Yellow)																		
5	(Grey)																		
6	(Pink)																		
7	(Blue)																		
8	(Red)																		
Connections Knox 2X Function +24 VDC Dynamic signal input 0 VDC Dynamic signal output Lock	<table border="1"> <thead> <tr> <th>5-pole</th> <th>Colour</th> </tr> </thead> <tbody> <tr><td>1</td><td>(Brown)</td></tr> <tr><td>2</td><td>(White)</td></tr> <tr><td>3</td><td>(Blue)</td></tr> <tr><td>4</td><td>(Black)</td></tr> <tr><td>5</td><td>(Grey)</td></tr> </tbody> </table>	5-pole	Colour	1	(Brown)	2	(White)	3	(Blue)	4	(Black)	5	(Grey)						
5-pole	Colour																		
1	(Brown)																		
2	(White)																		
3	(Blue)																		
4	(Black)																		
5	(Grey)																		
Warning Knox locks mechanically. Forcing the lock may damage Knox permanently. When mounting Knox on door with mesh the accessory PC plate for Knox is recommended. This is to prevent emergency opening from the outside. When mounting Knox on a low door it is recommended to replace emergency release handle with the accessory Escutcheon plate for Knox to prevent opening from the outside by reaching over.																			
Conformity	2006/42/EG EN ISO 12100-1/2:2003, EN ISO 13849-1:2008, EN 62061:2005, EN 1088																		
Certifications	CE																		

LED indicator – Knox	
LED indicator =Red =Green =Paus	Function
LED 1 	Locked (and reset) Locked, no dynamic signal in
	Unlocked
LED 2 	Reset Not reset
Alarm LED 2 	<i>Dirt indicator reset sensor</i> Reset Not reset

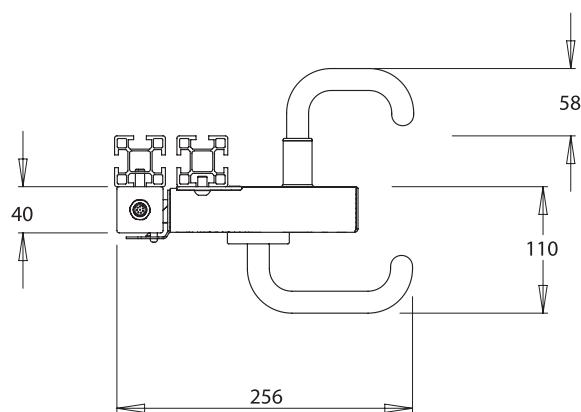
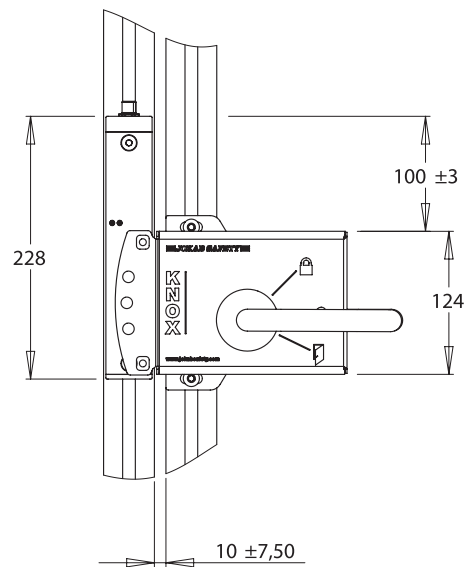

Connection example - Knox

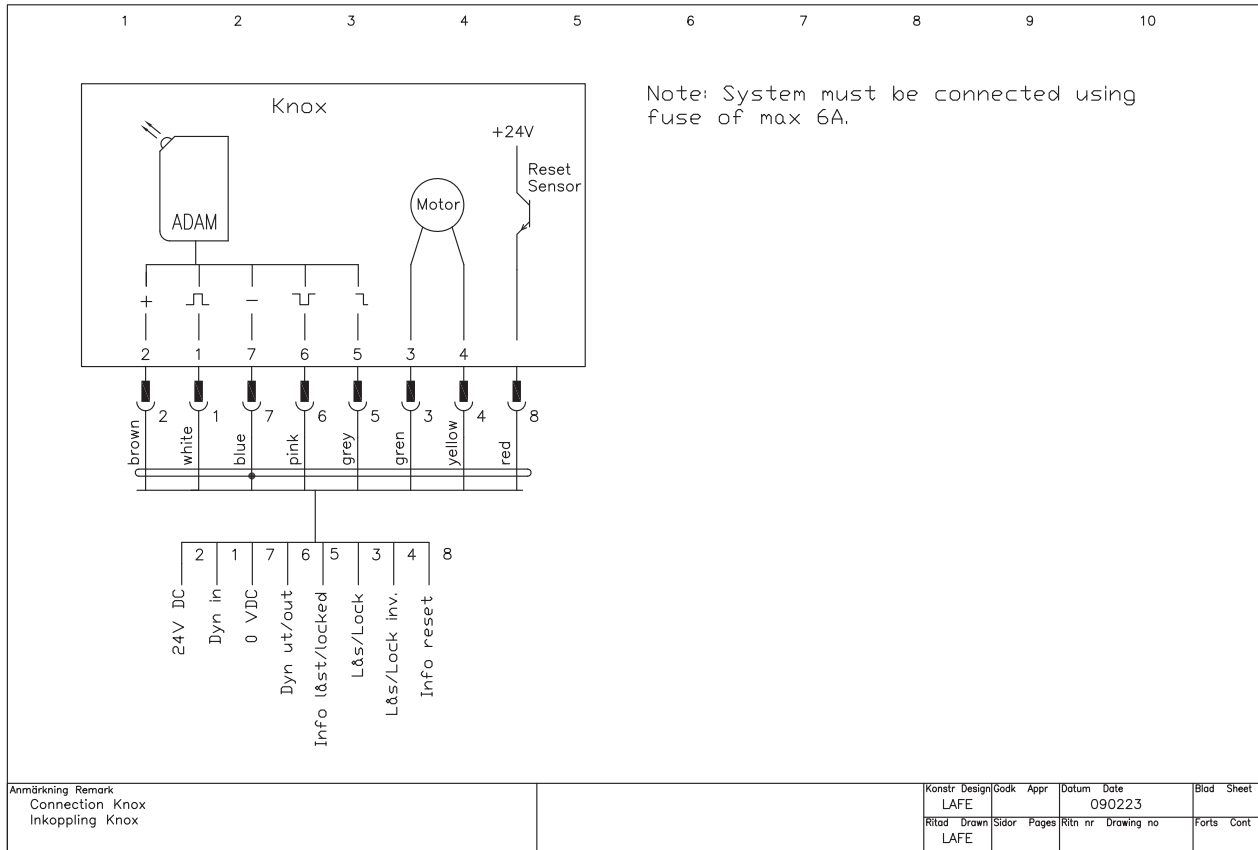

Connection example - Knox with other unlocking

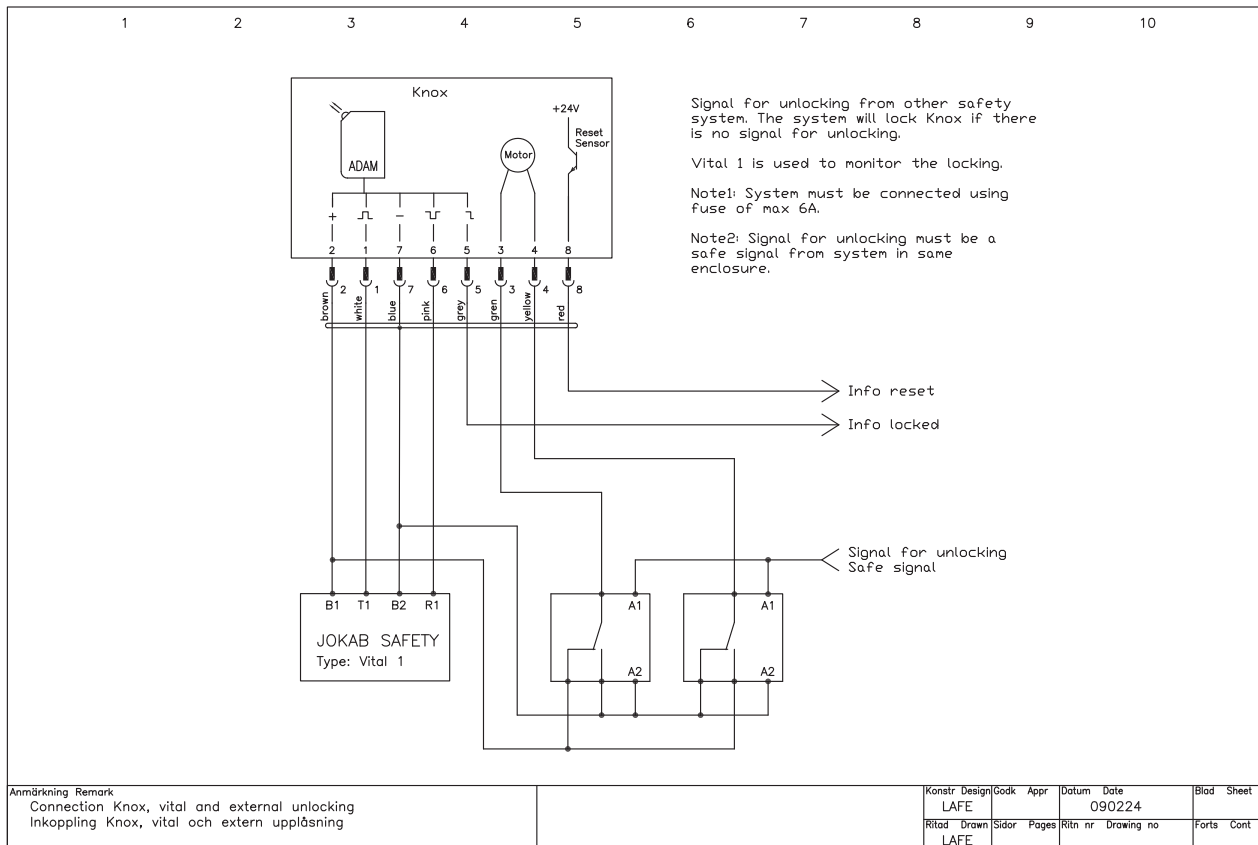

Connection example - Knox with downtime monitor

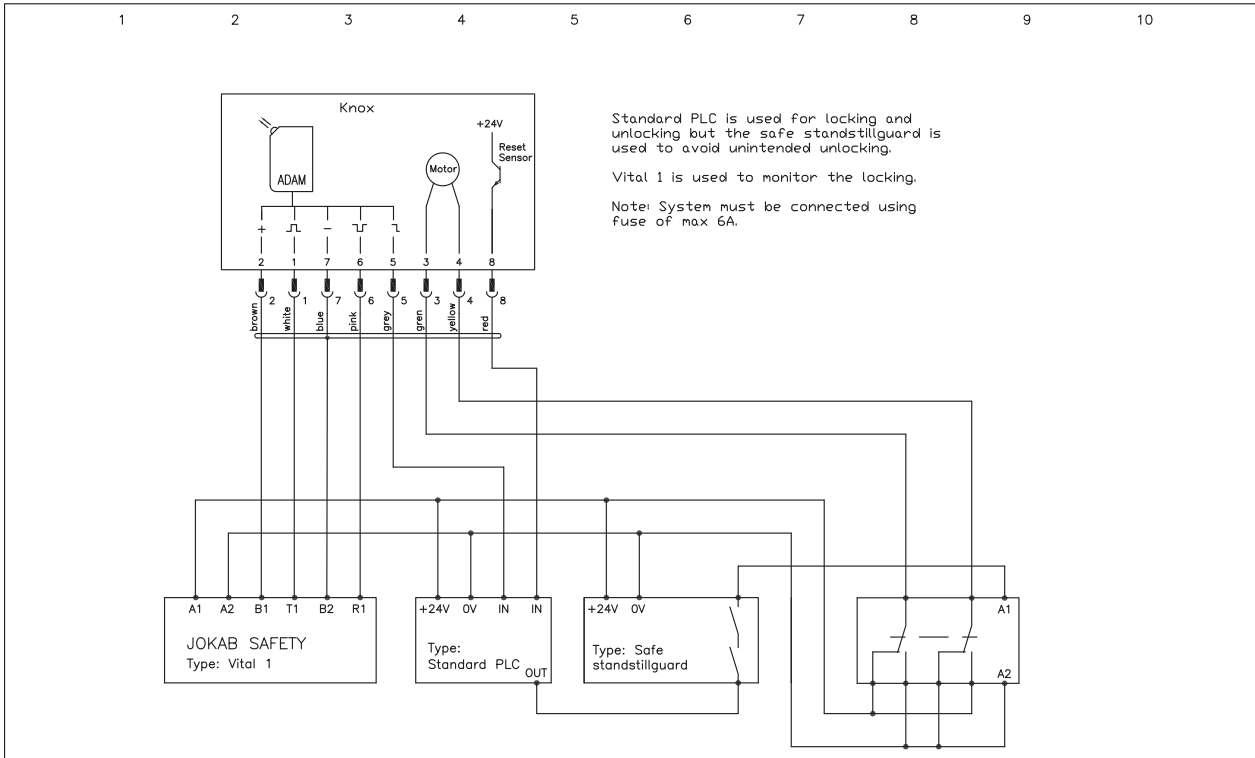

Standard PLC is used for locking and unlocking but the safe standstillguard is used to avoid unintended unlocking.

Vital 1 is used to monitor the locking.

Note: System must be connected using fuse of max 6A.

Anmärkning Remark Connection Knox, vital and standstillguard Inkoppling Knox, vital och stilleståndsvakt	Konstr Design	Gådk Appr	Datum Date	Blad Sheet
	LAFE		090224	
	Ritad Drawn	Sidor Pages	Ritn nr Drawing no	Forts Cont
	LAFE			