

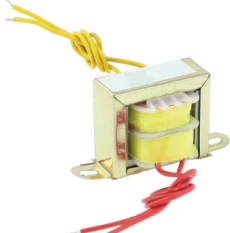

Dimming Low-Voltage LED MR16 Lamps

Light Emitting Diodes (LEDs), also known as Solid State Lighting (SSL), are replacing traditional light sources in almost all lighting applications. Low-voltage halogen MR16 lamps are among the sources being targeted for replacement by LEDs. Because these traditional halogen MR16 lamps are simple resistors, their electrical characteristics and performance are easy to model, regardless of whether they are fed from an ELV or MLV transformer. LED MR16 lamps are constructed with built-in electronic drivers and can cause several problems with dimming (See Technical Paper, [Challenges of Dimming LED Loads on ELV and MLV Transformers](#)).

Dimming Solutions with MR16 Lamps

- In the table below, identify the type of transformer used in your application.
- Ensure that the dimming control model used in your application is listed below. These are the only dimming controls recommended by Lutron to work successfully with MR16 lamps listed in this document.

Transformer	Dimming Control Models ¹	Dimming Range ²	Maximum Lamps per Transformer	Maximum Lamps per Control ³
MLV⁴ <ul style="list-style-type: none"> E-I Core  <ul style="list-style-type: none"> Toroidal 	NTLV-600-xx-CPN0199 ⁵	100%–20%	3	16
	VT-1000MN-x-xx ⁵			16
	GT-250M-xx ⁵			9
	GTJ-250M-xx ⁵			9
	MRF2-6ND-120-xx ⁵			9
	PD-10NXD-xx ⁵			16
	RRD-6NA-xx			9
	HQRD-6NA-xx			9
	RRD-10ND-xx ⁵			16
	HQRD-10ND-xx ⁵			16
	PHPM-PA-120-WH			30
	PHPM-WBX-120-WH			30
	HW/LP-RPM-4U-120 ⁵			Up to 30/channel; 30 total for module
	HW/LP-RPM-4A-120			Up to 19/channel; 30 total for module
	GP (Harrier) Card ⁵			30
ELV⁶ <ul style="list-style-type: none"> Hatch RS12-60M-LED Lightech LET-75 Lightech LET-60⁷ 	NTELV-300-xx	100%–20%	1	6
	NTELV-600-xx			12
	DVELV-300P-xx or DVELV-303P-xx			6
	CTELV-303P-xx			6
	SELV-300P-xx or SELV-303P-xx			6
	MAELV-600-xx			12
	MRF2-6ELV-120-xx			12
	PHPM-PA-120-WH			38
	PHPM-WBX-120-WH			38
	HW/LP-RPM-4A-120			Up to 24/channel; 38 total for module

¹ All dimming controls shown in this document require a neutral connection.

² This is the dimming range achievable with LED MR16 bulbs. A 20% measured light level is perceived as a 45% light level by the eye. For low-light level applications (e.g., restaurants, dining rooms, bar areas), energy-efficient halogen MR16 lamps can achieve a less than 1% measured light level which is perceived as a less than 10% light level by the eye. See *Energy-Efficient Halogen MR16 Lamps* table.

³ Consider each LED as 50 W. For ganging and derating, refer to dimmer installation guide.

⁴ All MLV transformers should be equipped with a primary fuse to protect against overheating.

⁵ Toroidal transformer requires LUT-LBX-WH.

⁶ ELV transformers are recommended for reducing audible noise from fixtures in new construction.

⁷ Lightech LET-60LW is **NOT** recommended for use with any LEDs listed in this document.

Note: If your application does not use any of the above-mentioned transformers, does not have a neutral connection at the wallbox location where dimming control is to be installed, and/or if it requires a dimming range of less than 20%, using high-efficacy halogen MR16 lamps is suggested (see *Energy-Efficient Halogen MR16 Lamps* table).

Continued on next page...

Dimming Solutions with MR16 Lamps (continued)

3. Select appropriate MR16 lamp.

- a. If you require a dimming range of 100%–20%, select one of the LED MR16 lamps from the following list. These LED MR16 lamps have been tested for performance and are recommended by Lutron.

LED MR16 Lamps

SORAA® GU5.3 Base: U.S.

Product Family	Model	Beam	Watts	Halogen Equivalent
VIVID 2700 7.5W CRI 95, R9 95	SM16-07-10D-927-03	10	7.5	50 W
	SM16-07-25D-927-03	25	7.5	50 W
	SM16-07-36D-927-03	36	7.5	50 W
VIVID 3000 7.5W CRI 95, R9 95	SM16-07-10D-930-03	10	7.5	50 W
	SM16-07-25D-930-03	25	7.5	50 W
	SM16-07-36D-930-03	36	7.5	50 W
VIVID 4000 7.5W CRI 95, R9 95	SM16-07-10D-940-03	10	7.5	50 W
	SM16-07-25D-940-03	25	7.5	50 W
	SM16-07-36D-940-03	36	7.5	50 W
VIVID 5000 7.5W CRI 95, R9 95	SM16-07-10D-950-03	10	7.5	50 W
	SM16-07-25D-950-03	25	7.5	50 W
	SM16-07-36D-950-03	36	7.5	50 W
BRILLIANT 2700K 7.5W CRI 80	SM16-07-10D-827-03	10	7.5	50 W
	SM16-07-25D-827-03	25	7.5	50 W
	SM16-07-36D-827-03	36	7.5	50 W
BRILLIANT 3000K 7.5W CRI 80	SM16-07-10D-830-03	10	7.5	50 W
	SM16-07-25D-830-03	25	7.5	50 W
	SM16-07-36D-830-03	36	7.5	50 W

Note: To view specific SORAA® specification sheets and lamp characteristics, visit www.soraa.com

or

- b. If you require a low-light level dimming range of less than 20%, select one of the energy-efficient halogen MR16 lamps from the following list. These are the only halogen MR16 lamps recommended by Lutron.

Energy-Efficient Halogen MR16 Lamps

Manufacturer	Model	Wattage		Dimming Range
		Rated	Equivalent	
GE Lighting	79586-Q30MR16HIR/CCG35	30 W	50 W	100%–1%
OSRAM	DECOSTAR 51 ECO SUPERSTAR	25 W	35 W	
		35 W	50 W	
Philips	Advantage IRC	20 W	35 W	
		30 W	50 W	
Sylvania	TRU-AIM	20 W	35 W	
		35 W	50 W	

4. Wire the load (see following pages for wallbox dimming control wiring diagrams).

Note: Refer to wiring diagrams in the product installation guides for PHPM interfaces, HW/LP-RPM modules, and GP dimming cards.



Wallbox Dimming Control Wiring

All dimming controls shown in this document require a neutral connection.

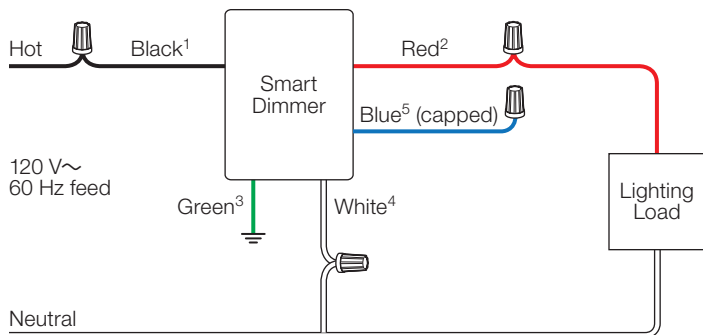
Digital Controls: Single-Pole Wiring



Key

-  Ground
-  Wire connector
- 1 Wire or black screw terminal*
- 2 Wire or brass/gold screw terminal*
- 3 Wire or green screw terminal*
- 4 Wire or silver screw terminal*
- 5 Wire or blue screw terminal*
- * Smart dimmers and companion dimmers have wires or screw terminals.

Digital Controls: Multi-Location Wiring (Load Side)

Note: Smart dimmer must be installed on the load side of the circuit (except for models GT-250M and GTJ-250M, which must be installed on the line side). See next diagram for Grafik T_M wiring.

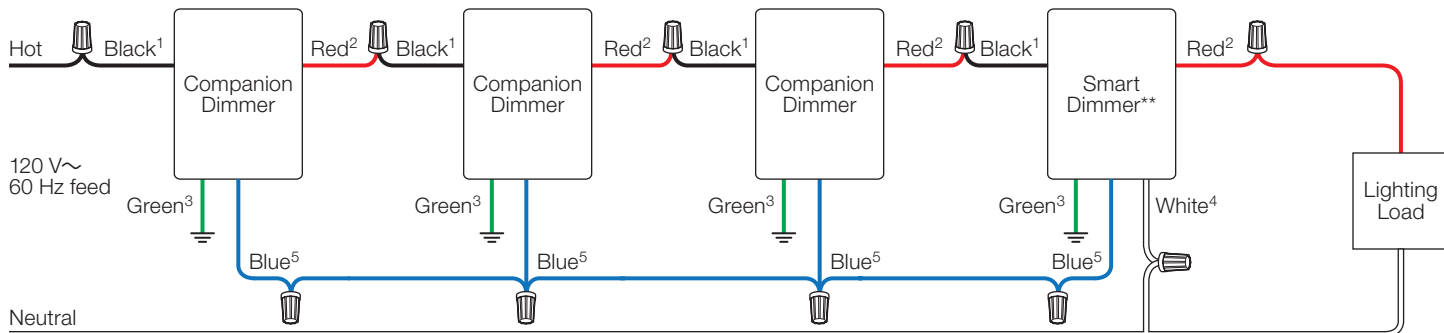

** Supports up to 9 total companion dimmers.

Digital Controls: Multi-Location Wiring (Line Side)

GT-250M, GTJ-250M, with GT-AD

Note: Control must be installed on the line side of the circuit if using neutral wire.

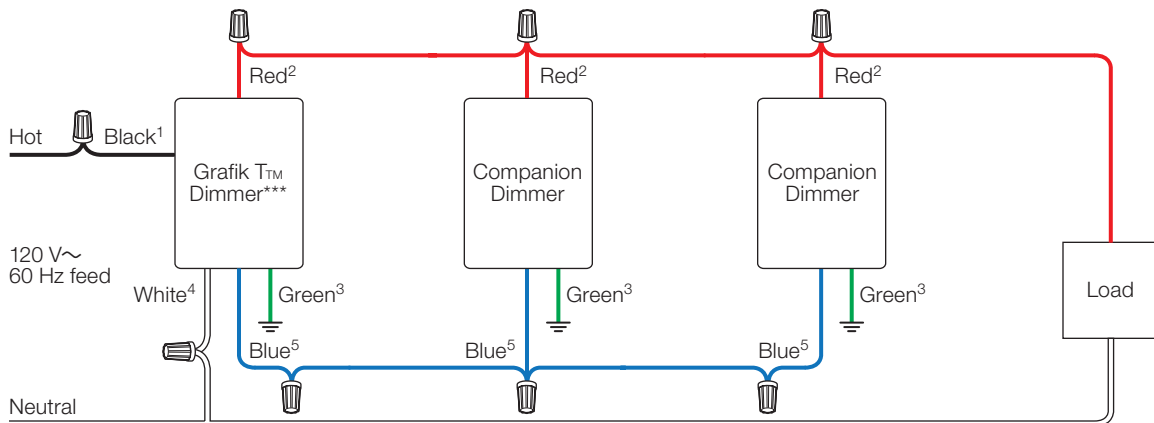

*** Supports up to 4 total companion dimmers. Total blue traveler wire length may be up to 150 ft (45 m).

Continued on next page...



Wallbox Dimming Control Wiring (continued)

All dimming controls shown in this document require a neutral connection.

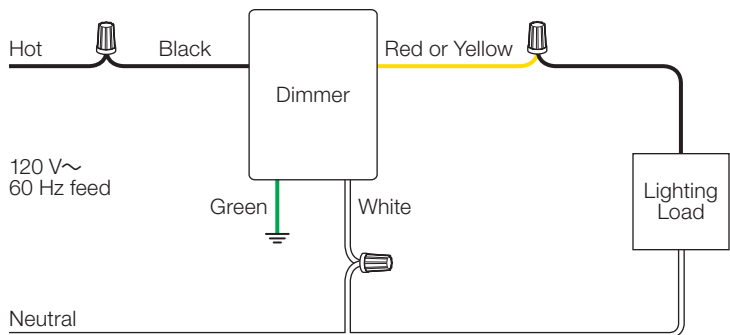
Analog Controls: Single-Pole Wiring



Key

-  Ground
-  Wire connector

Dimmers have wires; switches have screw terminals.

Analog Controls: 3-Way Wiring

Note: Dimmer must be installed on the load side of the circuit.

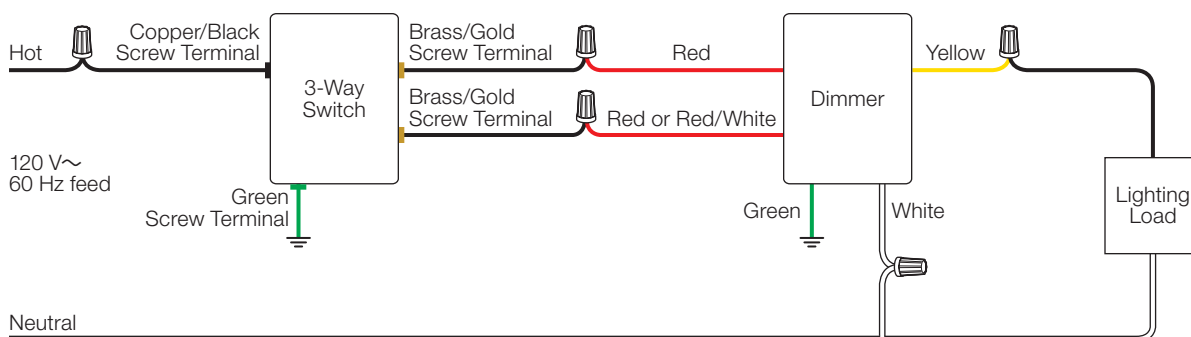

Lutron is a registered trademark of Lutron Electronics Co., Inc.

Lutron Contact Numbers

WORLD HEADQUARTERS USA

Lutron Electronics Co., Inc.
 7200 Suter Road
 Coopersburg, PA 18036-1299
 TEL: +1.610.282.3800
 FAX: +1.610.282.1243
 Toll-Free: 1.888.LUTRON1
 Technical Support: 1.800.523.9466
 intsales@lutron.com

North and South America
 Technical Hotlines

USA, Canada, Caribbean:
 1.800.523.9466

Mexico:
 +1.888.235.2910

Central/South America:
 +1.610.282.6701

EUROPEAN HEADQUARTERS United Kingdom

Lutron EA Ltd.
 6 Sovereign Close
 London, E1W 3JF United Kingdom
 TEL: +44.(0)20.7702.0657
 FAX: +44.(0)20.7480.6899
 FREEPHONE (UK): 0800.282.107
 Technical Support: +44.(0)20.7680.4481
 lutronlondon@lutron.com

ASIAN HEADQUARTERS Singapore

Lutron GL Ltd.
 390 Havelock Road
 #07-04 King's Centre
 Singapore 169662
 TEL: +65.6220.4666
 FAX: +65.6220.4333
 Technical Support: 800.120.4491
 lutronsea@lutron.com

Asia Technical Hotlines

Northern China: 10.800.712.1536
 Southern China: 10.800.120.1536
 Hong Kong: 800.901.849
 Indonesia: 001.803.011.3994
 Japan: +81.3.5575.8411
 Macau: 0800.401
 Taiwan: 00.801.137.737
 Thailand: 001.800.120.665853
 Other Countries: +65.6220.4666