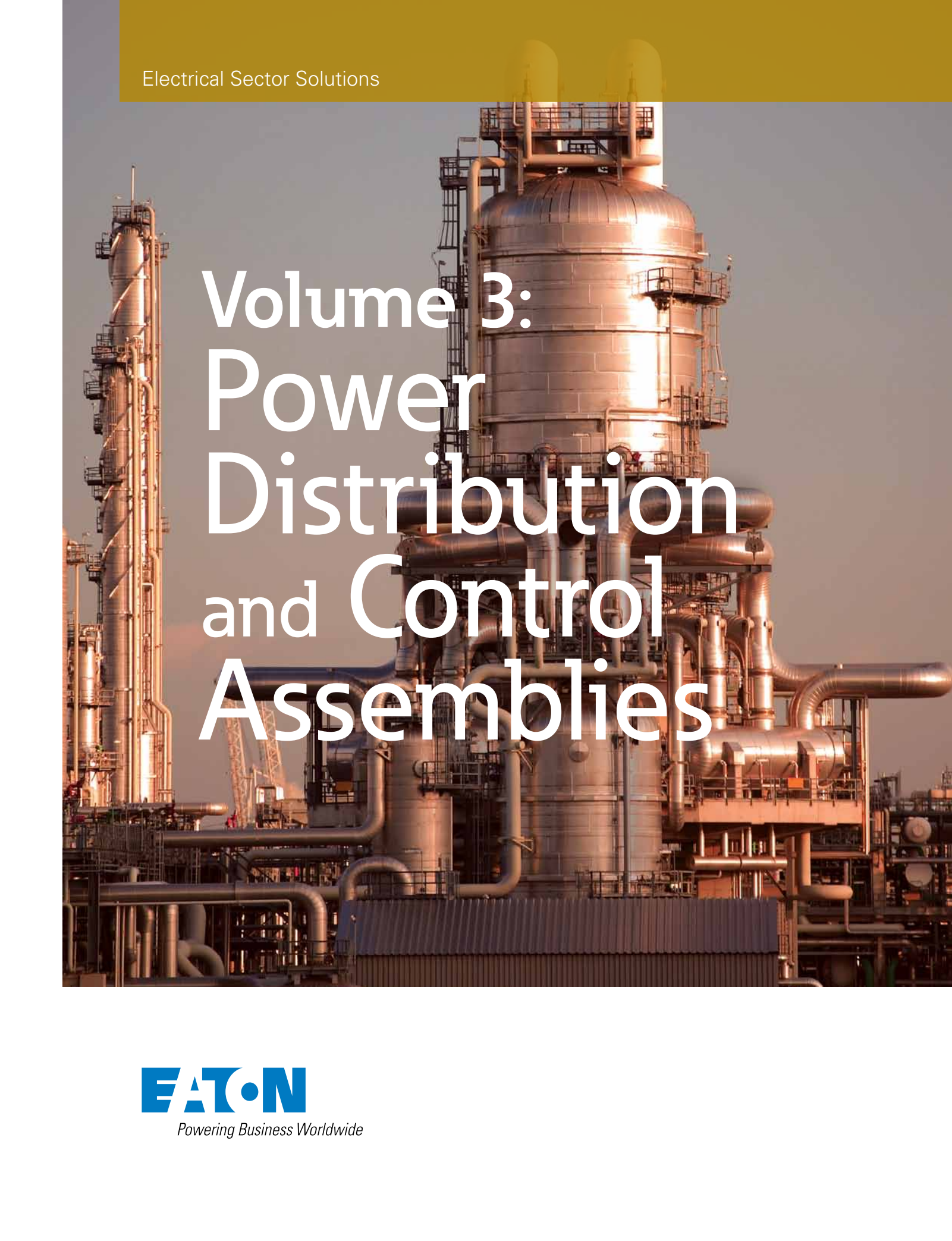

Electrical Sector Solutions

A large industrial facility, likely a refinery or power plant, featuring several tall, cylindrical storage tanks and a complex network of pipes and walkways. The scene is illuminated by warm, golden light, possibly from a low sun, creating a dramatic atmosphere. The tanks are metallic and have various ladders and platforms attached to them. The overall structure is dense and intricate.

Volume 3: Power Distribution and Control Assemblies

EATON

Powering Business Worldwide

Volume 3—Power Distribution and Control Assemblies

Tab 1—Medium Voltage Busway	V3-T1-1
Tab 2—SPD, Power Conditioning, PF Capacitors and Harmonic Filters	V3-T2-1
Tab 3—Motor Control Centers	V3-T3-1
Tab 4—Low Voltage Switchgear	V3-T4-1
Tab 5—Medium Voltage Motor Control Assemblies	V3-T5-1
Tab 6—Medium Voltage Metal-Enclosed Switches	V3-T6-1
Tab 7—Medium Voltage Switchgear	V3-T7-1
Tab 8—Network Protectors	V3-T8-1
Tab 9—Metering Devices, Protective Relays, Software and Connectivity	V3-T9-1
Tab 10—Power System Studies, Field Services and Conversion	V3-T10-1
Appendix 1—Eaton Terms & Conditions	V3-A1-1
Appendix 2—Catalog Parent Number Index	V3-A2-1
Appendix 3—Alphabetical Product Index	V3-A3-1



Dimensions, Weights and Ratings

Dimensions, weights and ratings given in this catalog **are approximate and should not be used for construction purposes**. Drawings containing exact dimensions are available upon request. All listed product specifications and ratings are subject to change without notice. Photographs are representative of production units.

Terms and Conditions

All prices and discounts are subject to change without notice. When price changes occur, they are published in Eaton's *Price and Availability Digest* (PAD). All orders accepted by Eaton's Electrical Sector are subject to the general terms and conditions as set forth in Appendix 1—Eaton Terms & Conditions.

Technical and Descriptive Publications

This catalog contains brief technical data for proper selection of products. Further information is available in the form of technical information publications and illustrated brochures. If additional product information is required, contact your local Eaton Products Distributor, call **1-800-525-2000** or visit our website at **www.eaton.com**.

Compliance with Nuclear Regulation 10 CFR 21

Eaton products are sold as commercial grade products not intended for application in facilities or activities licensed by the United States Nuclear Regulatory Commission for atomic purposes, under 10 CFR 21. Further certification will be required for use of these products in a safety-related application in any nuclear facility licensed by the U.S. Nuclear Regulatory Commission.

WARNING

The installation and use of Eaton products should be in accordance with the provisions of the U.S. National Electrical Code® and/or other local codes or industry standards that are pertinent to the particular end use. Installation or use not in accordance with these codes and standards could be hazardous to personnel and/or equipment.

These catalog pages do not purport to cover all details or variations in equipment, nor to provide for every possible contingency to be met in connection with installation, operation or maintenance. Should further information be desired or should particular problems arise which are not covered sufficiently for the purchaser's purposes, the matter should be referred to the local Eaton Products Distributor or Sales Office. The contents of this catalog shall not become part of or modify any prior or existing agreement, commitment or relationship. The sales contract contains the entire obligation of Eaton's Electrical Sector. The warranty contained in the contract between the parties is the sole warranty of Eaton. Any statements contained herein do not create new warranties or modify the existing warranty.



Powering Business Worldwide

Eaton is a global leader in power distribution, power quality, control and automation, and monitoring products.

At Eaton, we believe a reliable, efficient and safe power system is the foundation of every successful enterprise. Through innovative technologies, cutting-edge products and our highly skilled services team, we empower businesses around the world to achieve a powerful advantage.

In addition, Eaton is committed to creating and maintaining powerful customer relationships built on a foundation of excellence. From the products we manufacture to our dedicated customer service and support, we know what's important to you.

Solutions

Eaton takes the complexity out of power systems management with a holistic and strategic approach, leveraging our industry-leading technology, solutions and services. We focus on the following three areas in all we do:

- Reliability—maintain the appropriate level of power continuity without disruption or unexpected downtime
- Efficiency—minimize energy usage, operating costs, equipment footprint and environmental impact
- Safety—identify and mitigate electrical hazards to protect what you value most

Using the Eaton Catalog Library

As we grow, it becomes increasingly difficult to include all products in one or two comprehensive catalogs. Knowing that each user has their specific needs, we have created a library of catalogs for our products that when complete, will contain 15 volumes. Since the volumes will continuously be a work in progress and updated, each volume will stand alone. Refer to our volume directory, MZ08100001E, for a quick glance of where to look for the products you need. The 15 volumes include:

- Volume 1—Residential and Light Commercial (CA08100002E)
- Volume 2—Commercial Distribution (CA08100003E)
- Volume 3—Power Distribution and Control Assemblies (CA08100004E)
- Volume 4—Circuit Protection (CA08100005E)
- Volume 5—Motor Control and Protection (CA08100006E)
- Volume 6—Solid-State Motor Control (CA08100007E)
- Volume 7—Logic Control, Operator Interface and Connectivity Solutions (CA08100008E)
- Volume 8—Sensing Solutions (CA08100010E)
- Volume 9—Original Equipment Manufacturer (CA08100011E)
- Volume 10—Enclosed Control (CA08100012E)
- Volume 11—Vehicle and Commercial Controls (CA08100013E)
- Volume 12—Aftermarket, Renewal Parts and Life Extension Solutions (CA08105001E)
- Volume 13—Counters, Timers and Tachometers (CA08100015E)—Available in electronic format only
- Volume 14—Fuses (CA08100016E)—Available in electronic format only
- Volume 15—Solar Inverters and Electrical Balance of System (CA08100018E)

These volumes are not all-inclusive of every product, but they are meant to be an overview of our product lines. For our full range of product solutions and additional product information, consult Eaton.com/electrical and other catalogs and product guides in our literature library. These references include:

- The Consulting Application Guide (CA08104001E)
- The Eaton Power Quality Product Guide (COR01FYA)

If you don't have the volume that contains the product or information that you are looking for, not to worry. You can access every volume of the catalog library at Eaton.com/electrical in the Literature Library.

By installing our Automatic Tab Updater (ATU), you can be sure you always have the most recent version of each volume and tab.

Icons



Green Leaf

Eaton Green Solutions are products, systems or solutions that represent Eaton benchmarks for environmental performance. The green leaf symbol is our promise that the solution has been reviewed and documented as offering exceptional, industry-leading environmental benefits to customers, consumers and our communities. Though all of Eaton's products and solutions are designed to meet or exceed applicable government standards related to protecting the environment, our products with the Green Leaf designation further provide "exceptional environmental benefit".



Learn Online

When you see the Learn Online icon, go to Eaton.com/electrical and search for the product or training page. There you will find 100-level training courses, podcasts, webcasts or games and puzzles to learn more.



Drawings Online

When you see the Drawings Online icon, go to Eaton.com/electrical and find the products page. There you will find a tab that includes helpful product drawings and illustrations.

Contact Us

If you need additional help, you can find contact information under the Customer Care heading of Eaton.com/electrical.

**Nonsegregated Phase 600V—
Bus Run Section**



End View



1.1 Medium Voltage Busway—Nonsegregated Phase Bus

Application Description	V3-T1-2
Features, Benefits and Functions	V3-T1-2
Standards and Certifications	V3-T1-3
Additional Information	V3-T1-3
Technical Data and Specifications	V3-T1-3



Learn
Online

Nonsegregated Phase 600V, 10 kV BIL–5 kV, 60 kV BIL–15 kV,
95 kV BIL–38 kV, 170 kV BIL



Typical 5/15 kV Bus Run Section



End View

Application Description

Eaton's nonsegregated phase bus runs are designed for use on circuits whose importance requires greater reliability than power cables provide. Typical of such applications are the connections from transformers to switchgear assemblies in unit substations, connections from switchgear assemblies to rotating apparatus, and tie connections between switchgear assemblies. Nonsegregated phase bus is an assembly of bus conductors with associated connections, joints and insulating supports confined within a metal enclosure without interphase barriers. The conductors are adequately separated and insulated from each other and ground by insulating bus supports. Each conductor for 2400V service and above is insulated with a fluidized bed epoxy coating throughout that reduces the possibility of corona and electrical tracking.

Features, Benefits and Functions

Ease of Installation

Because of its compact dimensions, relative light weight and user-friendly design, nonsegregated phase bus is easily installed. The inherent rigidity of the design permits hanging rods to be spaced approximately every 4 ft (1.2m) for indoor bus runs, and allows supporting frames to be spaced approximately every 8 ft (2.4m) for outdoor runs. Standard length of bus run sections is 100 inches (2540 mm) or less.

Short-Circuit Force Withstand Ability

Nonsegregated phase bus runs in 600V, 5 kV and 15 kV are designed to withstand three-phase and phase-to-ground short-circuit current of 78 kA rms asymmetrical (132 kA peak) for 10 cycles and 50 kA rms symmetrical for 2 seconds. Momentary 4-cycle withstand ratings up to 158 kA peak (98.8 kA rms asymmetrical) are also available. For 27 kV nonsegregated phase bus runs, short-circuit withstand ratings of 64 kA rms asymmetrical (108 kA peak) for 10 cycles and 40 kA rms symmetrical for 2 seconds are standard.

Contents

Description

Standards and Certifications	V3-T1-3
Additional Information	V3-T1-3
Technical Data and Specifications	V3-T1-3

Page

V3-T1-3
V3-T1-3
V3-T1-3

Construction

Enclosures are fabricated from 11-gauge aluminum, and are welded for maximum rigidity. 11-gauge steel and stainless steel are options. Removable covers are secured with bolts for ease of access when making joints and subsequent and periodic inspection.

Enclosures are painted with a baked-on polyester powder coat paint system resulting in a very durable finish with uniform thickness and gloss. This cosmetically pleasing finish minimizes the risk of problems in harsh environments. The standard color is ANSI-61 light gray, and special paint colors are available upon request. Stainless steel hardware option is available.

Expansion joints are supplied in all straight bus runs at approximately 50 ft (15.2m) intervals to allow for the expected expansion when the conductors are energized and are carrying rated current.

A variety of terminations is available to accommodate most termination requirements. Bus runs can be terminated with flexible shunts, potheads, porcelain bushings, or conductor stub ends for connection to riser bars in switchgear assemblies.

Conductors

All conductors are 100% conductivity copper bars. Bus joints are made by solidly bolting the bus bars together with splice plates on each side. All joint surfaces are silver-plated to ensure maximum conductivity through the joint. Tin-plating is also available. After bolting, each standard joint is covered by a preformed, flame-retardant insulating boot, providing full insulation for bus conductors. These boots are easily removable for inspection of the joints at any future time.

Temperature Rise

The bus will be capable of carrying rated current continuously without exceeding a conductor temperature rise of 65°C above an outside ambient temperature of 40°C, as required by ANSI Standard C37.23.

Standards and Certifications

The metal-enclosed bus runs are designed for 600V, 5 kV, 15 kV, 27 kV and 38 kV service in accordance with ANSI C37.23. 600V, 5 kV and 15 kV bus is available with continuous current ratings of 1200, 2000, 3000, 3200 or 4000A. 27 kV and 38 kV bus is available in 1200 and 2000A continuous ratings.

Tests

The design of nonsegregated bus runs has been tested per ANSI C37.23. Certification of momentary current testing, impulse testing and heat rise are available upon request.

Seismic Application

Bus run assemblies are designed to meet Uniform Building Code (UBC) and California Code Title 24 for Seismic Zones 4, 3, 2A, 2B, 1 and 0. Complete guidelines for proper supports are provided on each seismic specified order.

Additional Information

- Technical Data: TD01702001E
- Brochure: BR01702001E
- Final Fit Program: SA01702001E
- *Consulting Application Guide*, CA08104001E

Technical Data and Specifications

Available Nonsegregated Bus Ratings per ANSI/IEEE Standard C37.23-1987

Rated Maximum Voltage kV rms	Rated Power Frequency Hz	Power Frequency Withstand 1 Min. Dry kV rms	Impulse Withstand (1.2 x 50 microsec) kV Peak	Rated Continuous Current Amperes	Rated Short-Time Short-Circuit Withstand Current (kA rms Symmetrical)		Rated Momentary Short-Circuit Withstand Current 10 Cycle	
					2 Sec.	1 Sec. ①	kA Peak	kA rms Asym.
0.635	60	2.2	10	1200	49	69	132 ②	78 ②
				2000				
				3000				
				4000				
				5000				
0.635	60	2.2	10	1200	63	89	170	100.8
				2000				
				3000				
				3200				
4.76	60	19	60	1200	49	—	132	78
				2000				
				3000				
				4000				
				5000				
4.76	60	19	60	1200	63	—	170	100.8
				2000				
				3000				
				3200				
8.25	60	36	95	1200	41	—	111	66
				2000				
				3000				
				4000				
				5000				
8.25	60	36	95	1200	63	—	170	100.8
				2000				
				3000				
				3200				
15	60	36	95	1200	48	—	130	77
				2000				
				3000				
				4000				
				5000				
15	60	36	95	1200	63	—	170	100.8
				2000				
				3000				
				3200				
27	60	60	125	1200	40	—	108	64
				2000				
38	60	80	170	1200	40	—	104	64
				2000				
				3000				
				3200				
				4000				
				5000				

Notes

- ① This is a value calculated from 2 second short-circuit current withstand rating based on relationship $I^2t = \text{constant}$.
- ② For 600V application, 4-cycle momentary current withstand rating up to 158 kA peak (98.8 kA rms asymmetrical) is also available.

Medium Voltage Nonsegregated Phase Bus—Standard Configurations

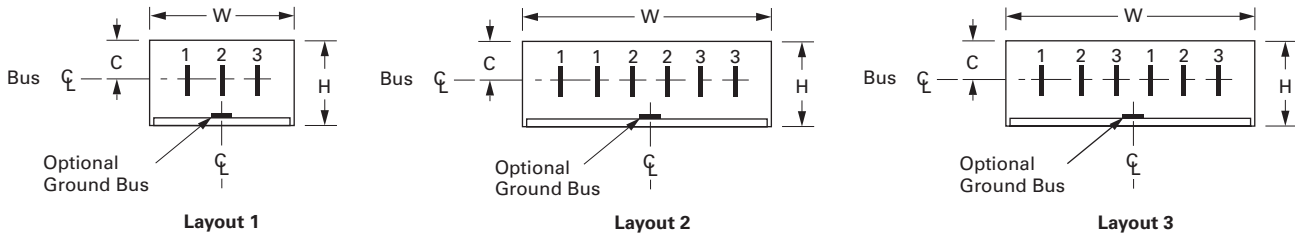

Bus Duct Rated 49 kA rms Symmetrical 2 Seconds

Wire	Voltage (kV) ^①	Ampere Rating	Layout Number	Width	Height	Conductor Centerline	Conductor Size	Phase-Phase Conductor Spacing	Bracing Supports ^②	Optional Ground Bus	Average Weight Per Foot Lbs (kg) ^③	Standards Listing
Aluminum Enclosures												
3	0.635/5/15	1200	1	20.00	17.38	8.13	(1) 0.5 x 3	5.38	Glass polyester	0.25 x 2	38 (17)	CSA
	0.635/5/15	2000	1	20.00	17.38	8.13	(1) 0.375 x 6	5.38	Glass polyester	0.25 x 2	47 (21)	CSA
	0.635/5/15	3000	1	20.00	17.38	8.13	(1) 0.5 x 8	5.38	Glass polyester	0.25 x 2	68 (31)	CSA
	0.635/5/15	3200	1	20.00	17.38	8.13	(1) 0.5 x 8	5.38	Glass polyester	0.25 x 2	68 (31)	—
	0.635/5/15	4000	2	35.75	17.38	8.13	(2) 0.5 x 6	5.38	Glass polyester	0.25 x 2	101 (46)	CSA
	0.635/5/15	5000	2	35.75	17.38	8.13	(2) 0.5 x 8	5.38	Glass polyester	0.25 x 2	118 (54)	CSA
4	0.635/5/15	1200	4	26.00	17.38	8.13	(1) 0.5 x 3	5.38	Glass polyester	0.25 x 2	48 (22)	CSA
	0.635/5/15	2000	4	26.00	17.38	8.13	(1) 0.375 x 6	5.38	Glass polyester	0.25 x 2	60 (27)	CSA
	0.635/5/15	3000	4	26.00	17.38	8.13	(1) 0.5 x 8	5.38	Glass polyester	0.25 x 2	88 (40)	—
	0.635/5/15	3200	4	26.00	17.38	8.13	(1) 0.5 x 8	5.38	Glass polyester	0.25 x 2	88 (40)	—
	0.635	4000	5	35.75	17.38	8.13	(2) 0.5 x 6	4.00	Glass polyester	0.25 x 2	127 (58)	—
Steel Enclosures (Steel, Stainless Steel and Galvanized Steel)												
3	0.635/5/15	1200	1	20.00	17.38	8.13	(1) 0.5 x 3	5.38	Glass polyester	0.25 x 2	58 (26)	CSA
	0.635/5/15	2000	1	20.00	17.38	8.13	(1) 0.375 x 6	5.38	Glass polyester	0.25 x 2	67 (30)	CSA
	0.635/5/15	3000	1	20.00	17.38	8.13	(1) 0.5 x 8	5.38	Glass polyester	0.25 x 2	106 (48)	—
	0.635/5/15	3200	1	20.00	17.38	8.13	(1) 0.5 x 8	5.38	Glass polyester	0.25 x 2	106 (48)	—
	0.635/5/15	4000	2	35.75	17.38	8.13	(2) 0.5 x 8	5.38	Glass polyester	0.25 x 2	154 (70)	—
	0.635/5/15	5000	3	35.75	17.38	8.13	(2) 0.5 x 8	5.38	Glass polyester	0.25 x 2	154 (70)	—
4	0.635/5/15	1200	4	26.00	17.38	8.13	(1) 0.5 x 3	5.38	Glass polyester	0.25 x 2	72 (33)	CSA
	0.635/5/15	2000	4	26.00	17.38	8.13	(1) 0.375 x 6	5.38	Glass polyester	0.25 x 2	84 (38)	CSA
	0.635/5/15	3000	4	26.00	17.38	8.13	(1) 0.5 x 8	5.38	Glass polyester	0.25 x 2	124 (56)	—
	0.635/5/15	3200	4	26.00	17.38	8.13	(1) 0.5 x 8	5.38	Glass polyester	0.25 x 2	124 (56)	—
	0.635	4000	5	35.75	17.38	8.13	(2) 0.5 x 8	4.00	Glass polyester	0.25 x 2	188 (85)	—

Notes

① All phase conductors above 635V are fully insulated with epoxy insulation for the rated maximum voltage. Epoxy insulation is available at 600V as an option.

② Optional poly/porcelain or poly/epoxy bracing supports are available. Consult factory.

③ Add 3 lbs to the weights shown when using poly/porcelain or poly/epoxy support bracing.

For dimensions in mm, multiply inches by 25.4.

Medium Voltage Busway—Nonsegregated Phase Bus

Medium Voltage Nonsegregated Phase Bus—Standard Configurations

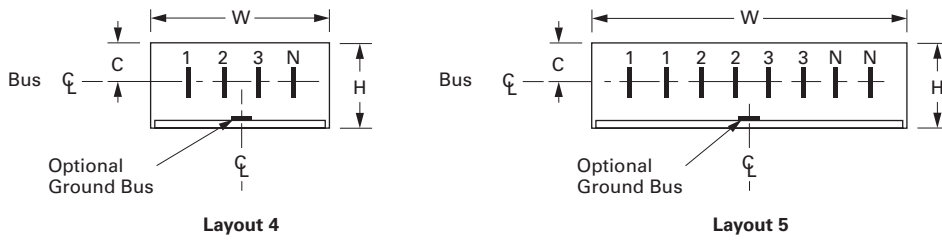

Bus Duct Rated 63 kA rms Symmetrical 2 Seconds

Wire	Voltage (kV) ^①	Ampere Rating	Layout Number	Width	Height	Conductor Centerline	Conductor Size	Phase-Phase Conductor Spacing	Bracing Supports ^②	Ground Bus	Average Weight Per Foot Lbs (kg) ^③	Standards Listing
Aluminum Enclosures												
3	0.635/5/15	1200	1	20.00	17.38	8.13	(1) 0.375 x 6	5.38	Glass polyester	0.25 x 3	48 (22)	CSA
	0.635/5/15	2000	1	20.00	17.38	8.13	(1) 0.375 x 6	5.38	Glass polyester	0.25 x 3	48 (22)	CSA
	0.635/5/15	3000	1	20.00	17.38	8.13	(1) 0.5 x 8	5.38	Glass polyester	0.25 x 3	78 (35)	CSA
	0.635/5/15	3200	1	20.00	17.38	8.13	(1) 0.5 x 8	5.38	Glass polyester	0.25 x 3	78 (35)	—
	0.635/5/15	4000	2	35.75	17.38	8.13	(2) 0.5 x 6	5.38	Glass polyester	0.25 x 3	105 (48)	—
	0.635/5/15	5000	2	35.75	17.38	8.13	(2) 0.5 x 8	5.38	Glass polyester	0.25 x 3	121 (55)	—
4	0.635/5/15	1200	4	26.00	17.38	8.13	(1) 0.375 x 6	5.38	Glass polyester	0.25 x 3	61 (28)	—
	0.635/5/15	2000	4	26.00	17.38	8.13	(1) 0.375 x 6	5.38	Glass polyester	0.25 x 3	61 (28)	—
	0.635/5/15	3000	4	26.00	17.38	8.13	(1) 0.5 x 8	5.38	Glass polyester	0.25 x 3	101 (46)	—
	0.635/5/15	3200	4	26.00	17.38	8.13	(1) 0.5 x 8	5.38	Glass polyester	0.25 x 3	101 (46)	—
	0.635	4000	5	35.75	17.38	8.13	(2) 0.5 x 6	4.00	Glass polyester	0.25 x 3	128 (58)	—
Steel Enclosures (Steel, Stainless Steel and Galvanized Steel)												
3	0.635/5/15	1200	1	20.00	17.38	8.13	(1) 0.375 x 6	5.38	Glass polyester	0.25 x 3	68 (31)	—
	0.635/5/15	2000	1	20.00	17.38	8.13	(1) 0.375 x 6	5.38	Glass polyester	0.25 x 3	68 (31)	—
	0.635/5/15	3000	1	20.00	17.38	8.13	(1) 0.5 x 8	5.38	Glass polyester	0.25 x 3	89 (40)	—
	0.635/5/15	3200	1	20.00	17.38	8.13	(1) 0.5 x 8	5.38	Glass polyester	0.25 x 3	89 (40)	—
	0.635/5/15	4000	2	35.75	17.38	8.13	(2) 0.5 x 6	5.38	Glass polyester	0.25 x 3	134 (61)	—
	0.635/5/15	5000	3	35.75	17.38	8.13	(2) 0.5 x 8	5.38	Glass polyester	0.25 x 3	160 (73)	—
4	0.635/5/15	1200	4	26.00	17.38	8.13	(1) 0.375 x 6	5.38	Glass polyester	0.25 x 3	85 (39)	—
	0.635/5/15	2000	4	26.00	17.38	8.13	(1) 0.375 x 6	5.38	Glass polyester	0.25 x 3	85 (39)	—
	0.635/5/15	3000	4	26.00	17.38	8.13	(1) 0.5 x 8	5.38	Glass polyester	0.25 x 3	115 (52)	—
	0.635/5/15	3200	4	26.00	17.38	8.13	(1) 0.5 x 8	5.38	Glass polyester	0.25 x 3	115 (52)	—
	0.635	4000	5	35.75	17.38	8.13	(2) 0.5 x 6	4.00	Glass polyester	0.25 x 3	188 (85)	—

Notes

- ① All phase conductors above 635V are fully insulated with epoxy insulation for the rated maximum voltage. Epoxy insulation is available at 600V as an option.
- ② Optional poly/porcelain or poly/epoxy bracing supports are available. Consult factory.
- ③ Add 3 lbs to the weights shown when using poly/porcelain or poly/epoxy support bracing.

For dimensions in mm, multiply inches by 25.4.

1.1

Medium Voltage Busway

Medium Voltage Busway—Nonsegregated Phase Bus

1

27 kV/38 kV Nonsegregated Phase Bus—Standard Configurations

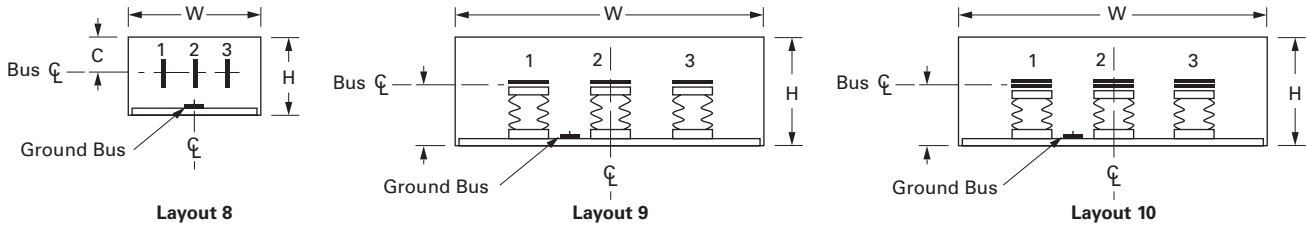

27 kV Bus Rated up to 108 kA Peak Momentary, 40 kA rms Symmetrical 2 Second

Wire Type	Rated Maximum Voltage kV ^①	Rated Cont. Current Amperes	Layout No.	Enclosure Material		Enclosure Size (Inches)			Number of Bars Ph and Size, Cu (Inches) ^①	Ph-Ph Bus Spacing (Inches)	Insulating Supports		Optional Ground Bus, Cu (Inches)	Approx. Average Weight per Foot Lbs (kg) ^③	Listing		
				Std.	Opt.	W	H	C			Std.	Opt. ^②			CSA	UL	
3	27	1200	8	Aluminum	—	30.00	21.13	10.00	(1) 0.25 x 4	7.00	④	⑤	⑥	0.25 x 2	37 (17)	Yes	No
	27	2000	8	Aluminum	—	30.00	21.13	10.00	(1) 0.50 x 4	7.00	④	⑤	⑥	0.25 x 2	49 (22)	Yes	No
	27	1200	8	—	Steel	30.00	21.13	10.00	(1) 0.25 x 4	7.00	④	⑤	⑥	0.25 x 2	37 (17)	Yes	No
	27	2000	8	—	Steel	30.00	21.13	10.00	(1) 0.50 x 4	7.00	④	⑤	⑥	0.25 x 2	49 (22)	Yes	No

38 kV Bus Rated up to 104 kA Peak Momentary, 40 kA rms Symmetrical 2 Second

Wire Type	Rated Maximum Voltage kV ^①	Rated Cont. Current Amperes	Layout No.	Enclosure Material		Enclosure Size (Inches)			Number of Bars Ph and Size, Cu (Inches)	Ph-Ph Bus Spacing (Inches)	Insulating Supports		Optional Ground Bus, Cu (Inches)	Approx. Average Weight per Foot Lbs (kg) ^③	Listing		
				Std.	Opt.	W	H	C			Std.	Opt. ^②			CSA	UL	
3	38	1200	9	Aluminum	—	40.25	21.50	11.00	(1) 0.25 x 4	10.50	Epoxy	—	—	0.25 x 3	61 (28)	Yes	No
	38	2000	10	Aluminum	—	40.25	21.50	11.00	(1) 0.38 x 4	10.50	Epoxy	—	—	0.25 x 3	89 (40.4)	Yes	No
	38	1200	9	—	Steel	40.25	21.50	11.00	(1) 0.25 x 4	10.50	Epoxy	—	—	0.25 x 3	88 (40)	No	No
	38	2000	10	—	Steel	40.25	21.50	11.00	(1) 0.38 x 4	10.50	Epoxy	—	—	0.25 x 3	116 (53)	No	No

Notes

- ① All bus bars for applications above 600V are fully insulated with fluidized epoxy coating for the rated maximum voltage.
- ② Check with Eaton for availability.
- ③ Add 3 lbs to the weights shown when using poly/porcelain or epoxy insulating supports in place of glass polyester.
- ④ Glass polyester.
- ⑤ Polyester/porcelain.
- ⑥ Epoxy.

For dimensions in mm, multiply inches by 25.4.

Medium Voltage Busway—Nonsegregated Phase Bus

Nonsegregated Phase Bus Electrical Properties and Watt Loss Data

Wire Type	Rated Max. Voltage kV	Cont. Rated Current Ampere	Conductor (Copper)				Enclosure	Size	Electrical Properties $\mu\text{OHM/PH/FT}$				$\mu\text{F/PH/FT}$ Cap to Grd Cg
			No./Ph	Thick Inch	Width Inch	Phase Arrang.			Material	W x H (Inches)	DC R 20°C	60 Hz R	
3	0.635/5/15	1200	1	0.50	3.00	1-2-3	Aluminum	20.00 x 17.38	5.5	7.1	49.8	50.3	2.2
	0.635/5/15	2000	1	0.38	6.00	1-2-3	Aluminum	20.00 x 17.38	3.7	4.7	37.0	37.3	4.4
	0.635/5/15	3000	1	0.50	8.00	1-2-3	Aluminum	20.00 x 17.38	2.1	2.	31.1	31.3	5.9
	0.635/5/15	3200	1	0.50	8.00	1-2-3	Aluminum	20.00 x 17.38	2.1	2.7	31.1	31.3	5.9
3	0.635/5/15	4000	2	0.50	6.00	1-1-2-2-3-3	Aluminum	35.75 x 17.38	1.4	1.8	35.6	35.6	5.9
	0.635/5/15	5000	2	0.50	8.00	1-1-2-2-3-3	Aluminum	35.75 x 17.38	1.0	1.3	32.9	32.9	7.8
	0.635/5/15	1200	1	0.50	3.00	1-2-3	Steel	20.00 x 17.38	5.5	7.1	49.8	50.3	2.2
	0.635/5/15	2000	1	0.38	6.00	1-2-3	Steel	20.00 x 17.38	3.7	4.7	37.0	37.3	4.4
3	0.635/5/15	3000	1	0.50	8.00	1-2-3	Steel	20.00 x 17.38	2.1	2.7	31.1	31.3	5.9
	0.635/5/15	3200	1	0.50	8.00	1-2-3	Steel	20.00 x 17.38	2.1	2.7	31.	31.	5.9
	0.635/5/15	4000	2	0.50	8.00	1-1-2-2-3-3	Steel	35.75 x 17.38	1.0	1.3	32.9	32.9	7.8
	0.635/5/15	5000	2	0.50	8.00	1-2-3-1-2-3	Steel	35.75 x 17.38	1.0	1.3	14.6	14.6	7.4
4	0.635/5/15	1200	1	0.50	3.00	1-2-3-N	Aluminum	26.00 x 17.38	5.5	7.1	49.8	50.3	1.5
	0.635/5/15	2000	1	0.38	6.00	1-2-3-N	Aluminum	26.00 x 17.38	3.7	4.7	37.0	37.3	3.1
	0.635/5/15	3000	1	0.50	8.00	1-2-3-N	Aluminum	26.00 x 17.38	2.1	2.7	31.1	31.3	4.1
	0.635/5/15	3200	1	0.50	8.00	1-2-3-N	Aluminum	26.00 x 17.38	2.1	2.7	31.1	31.3	4.1
	0.635	4000	2	0.50	6.00	1-1-2-2-3-3-N-N	Aluminum	35.75 x 17.38	1.4	1.8	35.6	35.6	4.9
4	0.635/5/15	1200	1	0.50	3.00	1-2-3-N	Steel	26.00 x 17.38	5.5	7.1	49.8	50.3	1.5
	0.635/5/15	2000	1	0.38	6.00	1-2-3-N	Steel	26.00 x 17.38	3.7	4.7	37.0	37.3	3.1
	0.635/5/15	3000	1	0.50	8.00	1-2-3-N	Steel	26.00 x 17.38	2.1	2.7	41.1	41.2	4.1
	0.635	3200	1	0.50	8.00	1-2-3-N	Steel	26.00 x 17.38	2.1	2.7	41.1	41.2	4.1
	0.635	4000	2	0.50	8.00	1-1-2-2-3-3-N-N	Steel	35.75 x 17.38	1.0	1.3	32.9	32.9	6.6
3	27	1200	1	0.25	4.00	1-2-3	Aluminum	30.00 x 21.00	8.3	10.6	51.6	52.7	1.7
	27	2000	1	0.50	4.00	1-2-3	Aluminum	30.00 x 21.00	4.1	5.3	24.8	25.4	1.7
	27	1200	1	0.25	4.00	1-2-3	Steel	30.00 x 21.00	8.3	10.6	51.6	52.7	1.7
	27	2000	1	0.50	4.00	1-2-3	Steel	30.00 x 21.00	4.1	5.3	24.8	25.4	1.7
3	38	1200	1	0.25	4.00	1-2-3	Aluminum	40.25 x 21.50	8.3	10.6	61.3	62.3	2.0
	38	2000	2	0.38	4.00	1-2-3	Aluminum	40.25 x 21.50	4.1	5.3	59.0	59.2	2.0
	38	1200	1	0.25	4.00	1-2-3	Steel	40.25 x 21.50	8.3	10.6	61.3	62.3	2.0
	38	2000	2	0.38	4.00	1-2-3	Steel	40.25 x 21.50	4.1	5.3	59.0	59.2	2.0

Note

For dimensions in mm, multiply inches by 25.4.

SPD, Power Conditioning, PF Capacitors and Harmonic Filters

Industrial Surge Protection Products



2.1 Surge Protection and Power Conditioning

Introduction	V3-T2-2
Product Overview	V3-T2-5
SPD Series for Integration into Electrical Distribution Equipment	V3-T2-7
SPD Series for Mounting External to Electrical Distribution Equipment	V3-T2-11
SPV Surge Protective Device	V3-T2-16
CVX050/100	V3-T2-18
SP1 Surge Protective Device	V3-T2-21
SP2 Surge Protective Device	V3-T2-23
AEGIS Powerline Filters	V3-T2-25
Sag Ride-Through (SRT)	V3-T2-30
Electronic Voltage Regulator (EVR)	V3-T2-36

2.2 Power Factor Correction and Harmonic Filtering

Product Overview	V3-T2-38
UNIPUMP	V3-T2-41
UNIPAK	V3-T2-44
AUTOVAR 300 Automatic Power Factor Correction Capacitor Systems	V3-T2-55
AUTOVAR 600 Automatic Power Factor Correction Capacitor Systems	V3-T2-58
AUTOVAR Filter—LV Automatic Harmonic Filter	V3-T2-63
Transient-Free Static Switching Power Factor Correction Units	V3-T2-67
Active-Harmonic Filter-Harmonic Correction Unit—NEMA 1 Enclosure	V3-T2-71

Industrial and Commercial Surge Protection

2



Contents

Description	Page
Introduction	
Product Overview	V3-T2-5
SPD Series for Integration into Electrical Distribution Equipment	V3-T2-7
SPD Series for Mounting External to Electrical Distribution Equipment	V3-T2-11
SPV Surge Protective Device	V3-T2-16
CVX050/100	V3-T2-18
SP1 Surge Protective Device	V3-T2-21
SP2 Surge Protective Device	V3-T2-23
AEGIS Powerline Filters	V3-T2-25
Sag Ride-Through (SRT)	V3-T2-30
Electronic Voltage Regulator (EVR)	V3-T2-36

Introduction

Industrial and Commercial Surge Protection

- SPD Series for Integration into Electrical Distribution Equipment
- SPD Series for Mounting External to Electrical Distribution Equipment

SPD Series Sidemount Units

Specification grade surge protective devices for installation external to electrical distribution equipment.

SPD Series Integrated Units

Specification grade surge protective devices installed within Eaton's electrical assemblies.

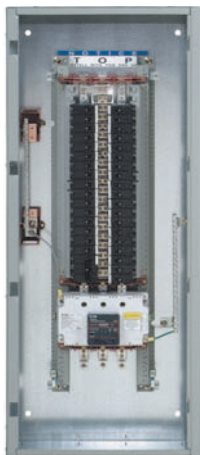

SPD Series Integrated Unit



SPD Series Sidemount Unit

Critical Load Protection

Series filtering and surge protection for critical single-phase loads.

- Current ratings up to 60A
- 120 and 240 Vac units
- 24 and 48 Vdc units
- DIN mounting available on some models
- Up to 80 kA of peak surge protection
- Most AC units are UL 1449 3rd Edition and UL 1283 5th Edition listed



AEGIS Products

Commercial and Light Industrial Surge Protection

Eaton's SPV series is a commercial grade and light industrial surge protective device (SPD) that combines surge suppression components and EMI/RFI filtering, providing effective protection for sensitive electronic loads.

Surges (also known as transients), due to lightning, utility grid switching, switching of external/internal inductive or capacitive loads, and other sources, travel on power line conductors throughout the electrical distribution system, causing system operating problems and equipment downtime.



SPV Series

Surge Protection for Sub-Panel and OEM Applications

In today's business environment that calls for 24 hours a day, 7 days a week uptime and reliability, Eaton's CVX050 and CVX100 surge protective devices (SPDs) ensure that a customer's investment in equipment and processes is protected from the damaging effects of voltage transients. Designed for installation on service entrance, branch panels or individual equipment disconnects, the CVX050/100 provides enhanced surge protection for mission-critical applications.



Panelboards with Integrated Surge Protective Devices

- Available in standard and custom configurations
- Ratings:
 - 120/240 Vac, single-phase, three-wire
 - 208Y/120 Vac, three-phase, four-wire
 - 480Y/277 Vac, three-phase, four-wire
 - 600Y/347 Vac, three-phase, four-wire (other voltage configurations are available)
- Copper bus
- 12, 18, 24, 30, 36 and 42 circuits
- Bolt-on branch breakers
- A full range of factory installed modifications and accessories
- Fully rated or series rated



Surge Protective Devices can be Integrated within a variety of Eaton Electrical Assemblies

Power Conditioning

Sag Ride-Through (SRT)

The sag ride-through (SRT) is a power conditioner that corrects voltage sags to maintain uptime and productivity.

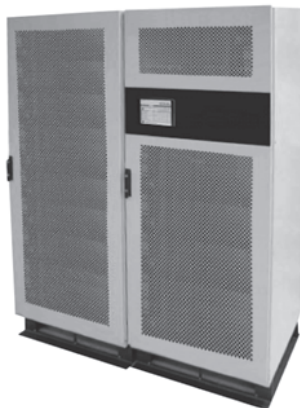

Sag Ride-Through (SRT)

Electronic Voltage Regulator (EVR)

The electronic voltage regulator (EVR) is designed to meet the needs of customers who experience voltage regulation problems due to brownout conditions from their electric utilities.



Electronic Voltage Regulator (EVR)

Facility-Wide Power Protection Solutions

A facility-wide protection approach should be employed to address power quality issues. This approach minimizes overall lifecycle costs and optimizes facility uptime. The following is a recommended design approach for implementing facility-wide Eaton power protection solutions.

The most accepted design methodology is based on two concepts:

1. Ensure proper grounding conditions exist. All forms of power protection/conditioning rely on good grounding, bonding and earthing practices.
2. Surge protection should be installed at key distribution panels and critical loads.

Application Description

2

Application Recommendations for Surge Products

Application Type	Eaton's Surge Product	Features and Competitive Advantages
Light Commercial		
Design build	SPD Series integrated units	Ideal package for any commercial facility
Chain stores	SPD Series sidemount units	Cost-effective, reliable protection using the SPD Series or SPV units
Small facilities	SPV units SP1 units CVX units	
Large Projects		
Including:	SPD Series integrated units in panelboards, switchboards, MCCs, switchgear, busway and automatic transfer switches	Able to meet competitors' surge protection specifications
Commercial		Increased surge protection performance by using integrated SPD Series units
Government	SPD Series sidemount units	Wall space savings by using integrated SPD Series units
Schools	SPV units	Quick-ship capabilities from Eaton assembly satellites and service centers
Institution	AEGIS units for critical load applications	Power conditioning capability for a wide variety of applications
Military	Power conditioners (EVR and SRT units)	
Industrial		
Including:	SPD Series integrated units in panelboards, switchboards, MCCs, switchgear, busway and automatic transfer switches	Increased surge protection performance by using integrated SPD Series units
Small and large facilities		Wall space savings by using integrated SPD Series units
WWTP	SPD Series sidemount units	MCCs with SPD Series units installed protect drives from damage
	SPV units	AEGIS products protect expensive critical loads from harmful damage
	AEGIS units for critical load applications such as PLCs, robotics applications, etc.	EVR units correct voltage regulation problems
	Power conditioners (EVR and SRT units)	SRT units correct voltage sag problems
OEM		
Any OEM customer including:	SPD Series integrated units	Years of experience in a variety of OEM applications
Integrators	SPD Series sidemount units	Application assistance and recommendations
Medical equipment	SPV units	Small footprint enables integration in a variety of applications
Automation and control	SP1 units CVX units AEGIS units for critical load applications	Ability to meet customized requirements
Telecommunications		
Including:	Panelboards and automatic transfer switches with integrated SPD Series units	Ability to meet customized requirements
Cellular sites	SPD Series sidemount units	Application assistance and recommendations
Microwave	SPV units	
PCS	SP1 units	
Paging systems	CVX units	

SPD Series Sidemount Units



Contents

<i>Description</i>	<i>Page</i>
Introduction	V3-T2-2
Product Overview	
SPD Series for Integration into Electrical Distribution Equipment	V3-T2-7
SPD Series for Mounting External to Electrical Distribution Equipment	V3-T2-11
SPV Surge Protective Device	V3-T2-16
CVX050/100	V3-T2-18
SP1 Surge Protective Device	V3-T2-21
SP2 Surge Protective Device	V3-T2-23
AEGIS Powerline Filters	V3-T2-25
Sag Ride-Through (SRT)	V3-T2-30
Electronic Voltage Regulator (EVR)	V3-T2-36



Product Overview

Product Description

Eaton’s SPD series surge protective devices are the latest and most advanced UL® 1449 3rd Edition certified surge protectors. Units are available integrated within Eaton electrical assemblies, including panelboards, switchboards, motor control centers, switchgear, automatic transfer switches and bus plugs.

A complete offering of sidemount units designed for mounting external to electrical distribution equipment is also available. Application of SPD Series units throughout a facility will ensure that equipment is protected with the safest and most reliable surge protective devices available. SPD Series units are available in all common voltages and configurations and also in a variety of surge current capacity ratings from 50 through 400 kA. Three feature package options are also available to choose from, ensuring the proper unit is available for a variety of applications.



SPD Series Integrated Units

Features, Benefits and Functions

- Uses self-protected metal oxide varistor (MOV) technology
- Three feature package options
- True protection status indicators report the status of the protection elements, not the status of the applied power
- Available integrated within the following Eaton electrical assemblies: panelboards, switchboards, motor control centers, switchgear, automatic transfer switches and bus plugs
- 10-year warranty (15-year warranty with registration)

Safety Features

- All units use self-protected metal oxide varistor technology (MOV) as their core surge suppression component. Usage of this technology ensures safe operation when the unit is subjected to abnormal conditions such as temporary overvoltage or high fault current conditions. Under such conditions, the self-protected MOVs are removed from the circuit quickly and safely before a potentially unsafe condition can occur
- SPD Series units contain no replaceable parts such as surge modules, fuses, or surge counter memory backup batteries. This prevents potential arc flash and shock hazards, as the units require no periodic service or user intervention after installation
- Integrated versions of the unit are factory installed and sidemount versions are factory sealed. These important safety measures further enhance user safety

2.1

SPD, Power Conditioning, PF Capacitors and Harmonic Filters

Surge Protection and Power Conditioning

2

Three Feature Package Options Available

The SPD Series provides users with the option of selecting between three feature packages. These feature packages are the basic, standard and standard with surge counter. The proper feature package can be selected based on the requirements of the application or specification. A side by side comparison of the individual features found in each package is below.

Basic Feature Package

The basic feature package is perfect for applications where basic, cost-effective, safe and reliable surge protection is required, but budgets don't allow for extra, additional features. Rather than sacrifice performance or safety due to cost, SPD Series units with the basic feature package provide you with high-performing surge protection without sacrificing safety or reliability. The basic feature package provides the same level of surge protection and safety provided by the standard and standard with surge counter feature packages minus some of the features found in them. The package contains dual-colored protection status LEDs that report the true status of the protection in each phase/mode. All four-wire plus ground units also contain an additional set of dual-colored protection status LEDs that report the status of the protection in the neutral/ground mode.

Standard Feature Package

The standard feature package includes all of the features found in the basic feature package, plus an audible alarm with silence button, EMI/RFI filtering, and a form 'C' relay contact that can be used for remote annunciation of the SPD's status. The audible alarm activates and the form 'C' relay contact changes state when any loss of protection is detected or a fault condition exists with the unit. Should such a condition occur, the audible alarm can be silenced by pressing the silence button. The EMI/RFI filter provides up to 50 dB of noise attenuation over the range of 10 kHz through 100 MHz.

Standard with Surge Counter Feature Package

The standard with surge counter feature package includes all of the features found in the standard feature package plus a six-digit surge counter with a reset button. The surge counter indicates the ongoing count of the number of surges the unit has been exposed to and stores them in nonvolatile memory. Should power to the SPD Series unit be completely interrupted, the surge counter will recall and display the surge count prior to the interruption when power is restored. Unlike many surge protectors, the SPD Series' surge counter memory feature does not require a backup battery that would require periodic replacement in order to achieve its memory functionality.

Side-By-Side Comparison of the SPD Series' Available Feature Packages

Feature Package Comparison	Basic	Standard	Standard with Surge Counter
Surge protection using self-protected MOV technology	■	■	■
Dual-colored protection status indicators for each phase	■	■	■
Dual-colored protection status indicators for the N-G protection mode	■	■	■
Audible alarm with silence button		■	■
Form 'C' relay contact		■	■
EMI/RFI filtering, providing up to 50 dB of noise attenuation from 10 kHz to 100 MHz		■	■
Surge counter with reset button			■

Standards and Certifications

- Integrated versions of the unit are UL 1449 3rd Edition recognized components for the United States and Canada, covered by Underwriters Laboratories certification and follow-up service
- Sidemount versions are UL 1449 3rd Edition listed devices and are also CSA approved



Technical Data and Specifications

- 20 kA nominal discharge current (I_n) rating (maximum rating assigned by UL)
- 50 through 400 kA surge current capacity ratings
- 200 kA short-circuit current rating (SCCR)

SPD Series Unit Integrated within an Eaton Panelboard



Contents

<i>Description</i>	<i>Page</i>
Introduction	V3-T2-2
Product Overview	V3-T2-5
SPD Series for Integration into Electrical Distribution Equipment	
Standards and Certifications	V3-T2-8
Catalog Number Selection	V3-T2-8
Technical Data and Specifications	V3-T2-9
Dimensions	V3-T2-10
SPD Series for Mounting External to Electrical Distribution Equipment	V3-T2-11
SPV Surge Protective Device	V3-T2-16
CVX050/100	V3-T2-18
SP1 Surge Protective Device	V3-T2-21
SP2 Surge Protective Device	V3-T2-23
AEGIS Powerline Filters	V3-T2-25
Sag Ride-Through (SRT)	V3-T2-30
Electronic Voltage Regulator (EVR)	V3-T2-36

SPD Series for Integration into Electrical Distribution Equipment

Product Description

Eaton’s SPD Series surge protective devices are the latest and most advanced UL 1449 3rd Edition certified surge protectors. SPD Series units are available in all common voltages and configurations, and also in a variety of surge current capacity ratings from 50 to 400 kA.

Application Description

The SPD Series is available as an integrated device within the following Eaton electrical assemblies:

- Panelboards
- Switchboards
- Motor control centers
- Switchgear
- Automatic transfer switches
- Bus plugs

Features, Benefits and Functions

- Uses thermally protected metal oxide varistor (MOV) technology
- Three feature package options
- 10-year warranty

The Integrated SPD Performance Advantage

Installation conductor length is the single most important factor related to an SPD’s performance. Performance decreases as the connected conductor length increases. Integrating the SPD within the electrical assembly provides the best possible surge protection by keeping installation conductor lead lengths as short as possible. Integrating the SPD within an electrical assembly can decrease let-through voltages by hundreds of volts, providing you with the best possible surge protection for sensitive electronic loads.

Remote Display Mounting Option Available

The SPD Series offers the option of mounting its display remotely from the device. This is useful for applications where OEMs or other integrators would like to embed the unit within a piece of equipment and still be able to view its display.



In this installation, the SPD Series is mounted directly to the panelboard’s bus bars. This type of installation will provide the best possible surge protection by minimizing the connected lead length.



The SPD Series is also available as an integrated unit interfaced via a circuit breaker resident in the electrical assembly. This installation keeps connected lead lengths short while providing a means of disconnecting power to the unit quickly and easily.

2.1

SPD, Power Conditioning, PF Capacitors and Harmonic Filters

Surge Protection and Power Conditioning

2

Standards and Certifications

- UL 1449 3rd Edition recognized component for the United States and Canada, covered by Underwriters Laboratories certification and follow-up service
- UL 1283 (Type 2 SPDs only)



Catalog Number Selection

SPD Series Units Mounted Internal to Electrical Distribution Equipment

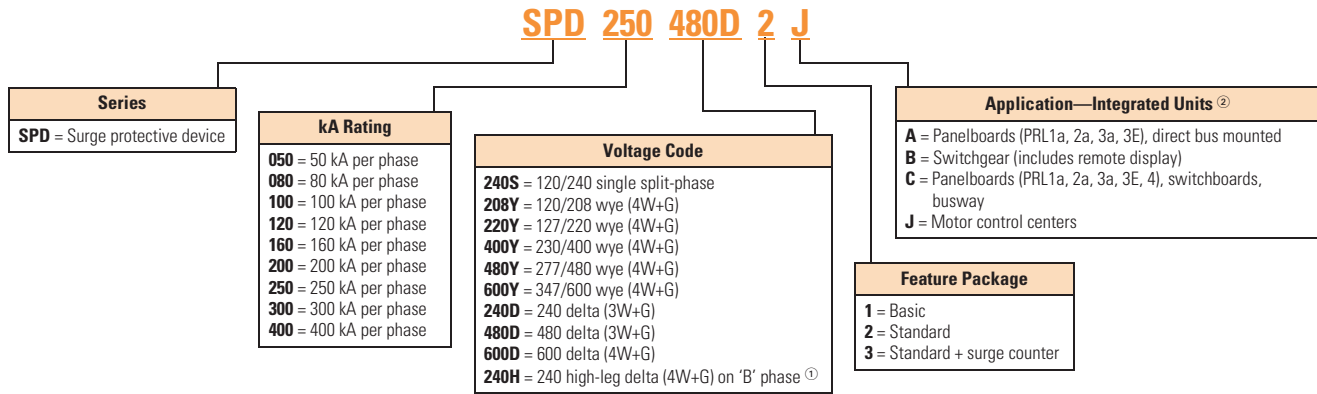

Notes

- ^① Please consult the factory for 240 high-leg delta (4W+G) applications with high leg on 'C' phase.
- ^② Units used in PRL1a, 2a, 3a and 3E panelboard applications are available in 50–200 kA ratings only. Use the 'C' option for PRL1a, 2a, 3a and 3E panelboard applications when unit is connected through a circuit breaker.

Example: SPD250480D2J = SPD Series, 250 kA per phase, 480D voltage, standard feature package, motor control center application.

Technical Data and Specifications

SPD Series Specifications

Description	Specification
Surge capacity ratings available	50, 80, 100, 120, 160, 200, 250, 300, 400 kA per phase
Nominal discharge current (I_n)	20 kA (maximum rating assigned by UL)
Short-circuit current rating (SCCR)	200 kA
SPD type	Basic feature package = Type 1 (can also be used in Type 2 applications) Standard and standard with surge counter feature packages = Type 2
Single split-phase voltages available	120/240
Three-phase wye system voltages available	120/208, 127/220, 230/400, 277/480, 347/600
Three-phase delta system voltages available	240, 480, 600
Input power frequency	50/60 Hz
Power consumption (basic units):	
208Y, 220Y, 240S, 240D and 240H voltage codes	0.5W
400Y, 480Y and 480D voltage codes	1.1W
600Y and 600D voltage codes	1.3W
Power consumption (standard and standard with surge counter units):	
208Y, 220Y, 240S, 240D and 240H voltage codes	0.6W
400Y, 480Y and 480D basic voltage codes	1.7W
600Y and 600D voltage codes	2.1W
Protection modes	Single split-phase L-N, L-G, N-G, L-L Three-phase wye L-N, L-G, N-G, L-L Three-phase delta L-G, L-L Three-phase high-leg delta L-N, L-G, N-G, L-L
Maximum continuous operating voltage (MCOV):	
240S, 208Y, 220Y and 240H MCOV	150 L-N, 150 L-G, 150 N-G, 300 L-L
400Y and 480Y MCOV	320 L-N, 320 L-G, 320 N-G, 640 L-L
600Y MCOV	420 L-N, 420 L-G, 420 N-G, 840 L-L
240D MCOV	320 L-G, 320 L-L
480D MCOV	640 L-G, 640 L-L
600D MCOV	840 L-G, 840 L-L
Ports	1
Operating temperature	-40°F through 122°F (-40°C through 50°C)
Operating humidity	5% through 95%, noncondensing
Operating altitude	Up to 16,000 ft (5000m)
Seismic withstand capability	Meets or exceeds the requirements specified in IBC 2006, CBC 2007 and UBC Zone 4
Form C relay contact ratings	150 Vdc or 125 Vac, 1A maximum
Form C relay contact logic	Power ON, normal state—NO contact = open, NC contact = closed Power OFF or fault state—NO contact = closed, NC contact = open
EMI/RFI filtering attenuation	Up to 50 dB from 10 kHz to 100 MHz

2.1

SPD, Power Conditioning, PF Capacitors and Harmonic Filters

Surge Protection and Power Conditioning

Dimensions

Approximate Dimensions in Inches (mm)

2

50–200 kA Integrated Units

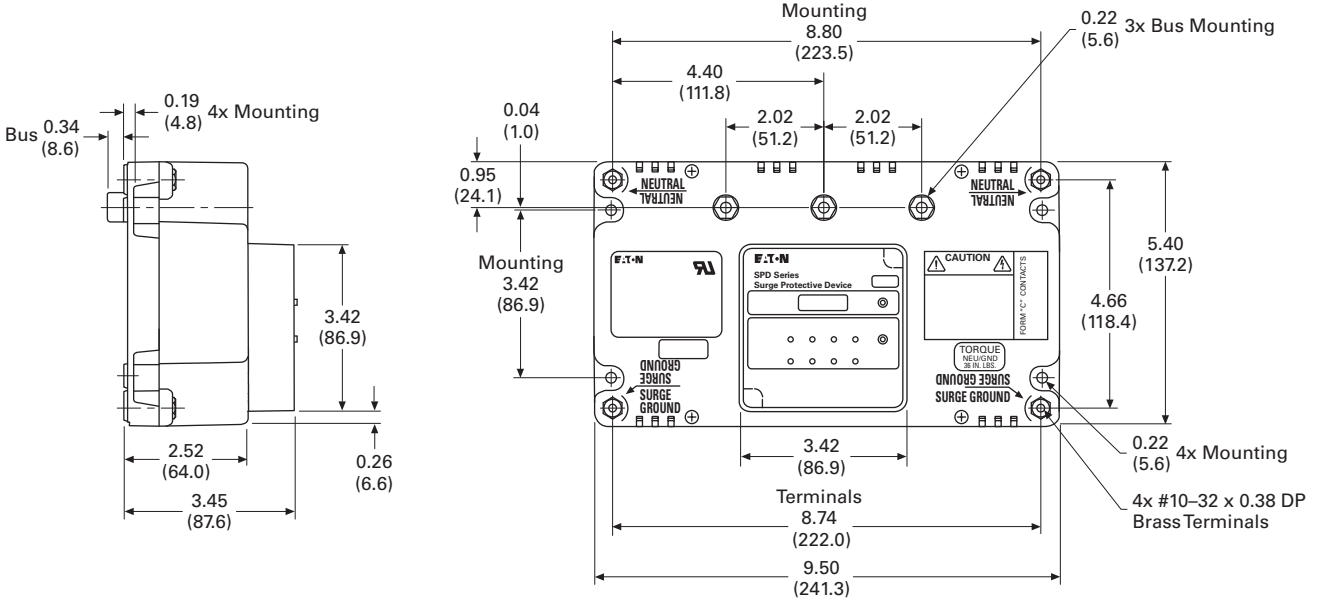

250–400 kA Integrated Units

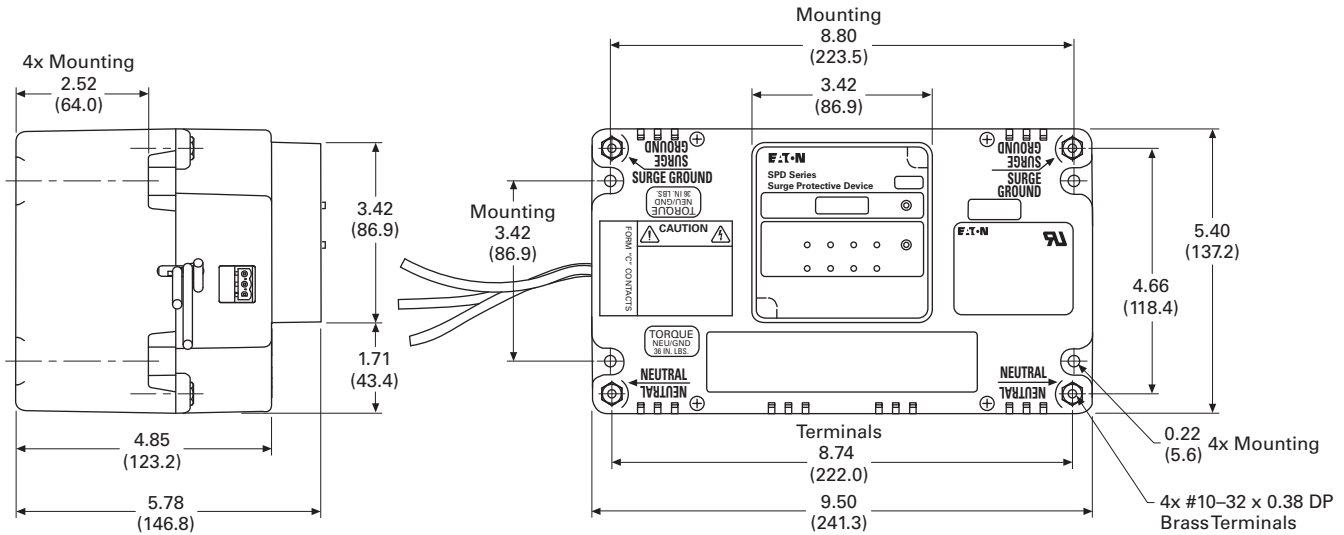

Weights

- 50–200 kA units approximately 3.5 lbs (1.6 kg)
- 250–400 kA units approximately 7.0 lbs (3.2 kg)

Eaton SPD Series Sidemount Unit Mounted Externally to an Eaton Panelboard



Contents

<i>Description</i>	<i>Page</i>
Introduction	V3-T2-2
Product Overview	V3-T2-5
SPD Series for Integration into Electrical Distribution Equipment	V3-T2-7
SPD Series for Mounting External to Electrical Distribution Equipment	
Catalog Number Selection	V3-T2-12
Technical Data and Specifications	V3-T2-13
Dimensions	V3-T2-14
SPV Surge Protective Device	V3-T2-16
CVX050/100	V3-T2-18
SP1 Surge Protective Device	V3-T2-21
SP2 Surge Protective Device	V3-T2-23
AEGIS Powerline Filters	V3-T2-25
Sag Ride-Through (SRT)	V3-T2-30
Electronic Voltage Regulator (EVR)	V3-T2-36

SPD Series for Mounting External to Electrical Distribution Equipment

Product Description

Eaton's sidemount versions of the SPD Series surge protective devices are the latest and most advanced UL 1449 3rd Edition listed surge protectors. Application of SPD Series units throughout a facility will ensure that equipment is protected with the safest and most reliable surge protective devices available. Units are available in all common voltages and configurations, and also in a variety of surge current capacity ratings from 50 through 400 kA. Three feature package options are also available to choose from.

Features, Benefits and Functions

- Uses self-protected metal oxide varistor (MOV) technology
- Three feature package options
- 15-year warranty

Standards and Certifications

- UL 1449 3rd Edition listed device
- Canadian Standards Association (CSA)
- UL 1283 (Type 2 SPDs only)



All SPD Series sidemount units come prewired and include a factory-installed conduit interface, making installation very easy.



All SPD Series units are factory sealed, ensuring that the user/installer has no potential of coming into contact with harmful voltages present inside the unit.

2.1

SPD, Power Conditioning, PF Capacitors and Harmonic Filters

Surge Protection and Power Conditioning

Catalog Number Selection

2

SPD Series Units for Mounting External to Electrical Distribution Equipment

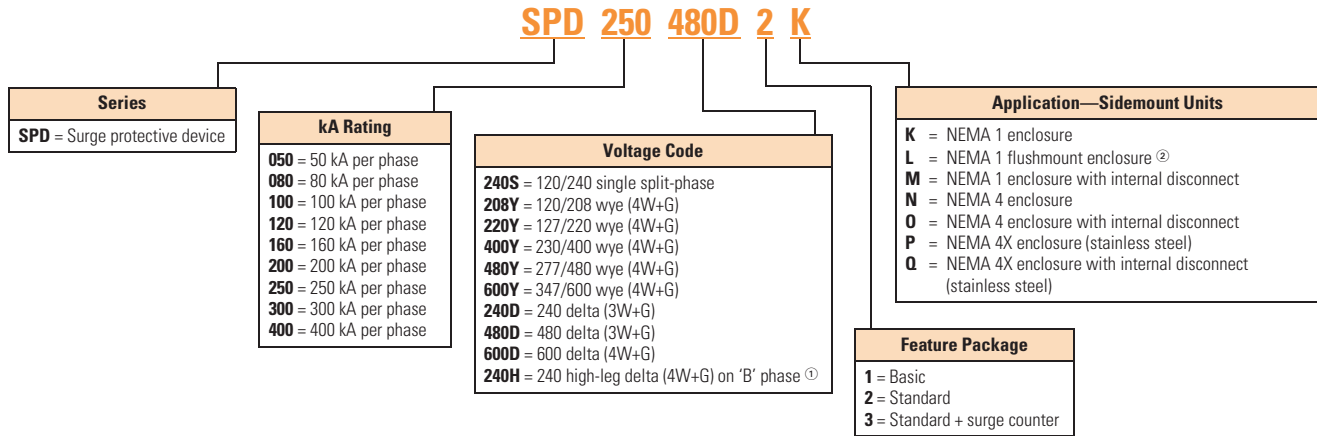

Notes

① Please consult the factory for 240 high-leg delta (4W+G) applications with high leg on 'C' phase.

② NEMA 1 flushmount units are available in 50–200 kA ratings only.

Example: SPD250480D2K = SPD Series, 250 kA per phase, 480D voltage, standard feature package, housed in NEMA 1 enclosure.

Technical Data and Specifications

SPD Series Specifications

Description	Specification								
Surge capacity ratings available	50, 80, 100, 120, 160, 200, 250, 300, 400 kA per phase								
Nominal discharge current (I_n)	20 kA (maximum rating assigned by UL)								
Short-circuit current rating (SCCR)	200 kA								
SPD type	Basic feature package = Type 1 (can also be used in Type 2 applications) Standard and standard with surge counter feature packages = Type 2								
Single split-phase voltages available	120/240								
Three-phase wye system voltages available	120/208, 127/220, 230/400, 277/480, 347/600								
Three-phase delta system voltages available	240, 480, 600								
Input power frequency	50/60 Hz								
Power consumption (basic units):									
208Y, 220Y, 240S, 240D and 240H voltage codes	0.5W								
400Y, 480Y and 480D voltage codes	1.1W								
600Y and 600D voltage codes	1.3W								
Power consumption (standard and standard with surge counter units):									
208Y, 220Y, 240S, 240D and 240H voltage codes	0.6W								
400Y, 480Y and 480D basic voltage codes	1.7W								
600Y and 600D voltage codes	2.1W								
Protection modes	<table border="0"> <tr> <td>Single split-phase</td> <td>L-N, L-G, N-G, L-L</td> </tr> <tr> <td>Three-phase wye</td> <td>L-N, L-G, N-G, L-L</td> </tr> <tr> <td>Three-phase delta</td> <td>L-G, L-L</td> </tr> <tr> <td>Three-phase high-leg delta</td> <td>L-N, L-G, N-G, L-L</td> </tr> </table>	Single split-phase	L-N, L-G, N-G, L-L	Three-phase wye	L-N, L-G, N-G, L-L	Three-phase delta	L-G, L-L	Three-phase high-leg delta	L-N, L-G, N-G, L-L
Single split-phase	L-N, L-G, N-G, L-L								
Three-phase wye	L-N, L-G, N-G, L-L								
Three-phase delta	L-G, L-L								
Three-phase high-leg delta	L-N, L-G, N-G, L-L								
Maximum continuous operating voltage (MCOV):									
240S, 208Y, 220Y and 240H MCOV	150 L-N, 150 L-G, 150 N-G, 300 L-L								
400Y and 480Y MCOV	320 L-N, 320 L-G, 320 N-G, 640 L-L								
600Y MCOV	420 L-N, 420 L-G, 420 N-G, 840 L-L								
240D MCOV	320 L-G, 320 L-L								
480D MCOV	640 L-G, 640 L-L								
600D MCOV	840 L-G, 840 L-L								
Ports	1								
Operating temperature	-40°F to 122°F (-40°C to 50°C)								
Operating humidity	5% through 95%, noncondensing								
Operating altitude	Up to 16,000 ft (5000m)								
Seismic withstand capability	Meets or exceeds the requirements specified in IBC 2006, CBC 2007 and UBC Zone 4								
Enclosure dimensions and weights	Refer to figures on Pages V3-T2-14–V3-T2-15 for enclosure dimensions and weights								
Form C relay contact ratings	150 Vdc or 125 Vac, 1A maximum								
Form C relay contact logic	Power ON, normal state—NO contact = open, NC contact = closed Power OFF or fault state—NO contact = closed, NC contact = open								
EMI/RFI filtering attenuation	Up to 50 dB from 10 kHz to 100 MHz								

2.1

SPD, Power Conditioning, PF Capacitors and Harmonic Filters

Surge Protection and Power Conditioning

Dimensions

Approximate Dimensions in Inches (mm)

2

50–200 kA Units in a NEMA 1 Rated Enclosure, Weight = 6.8 lbs

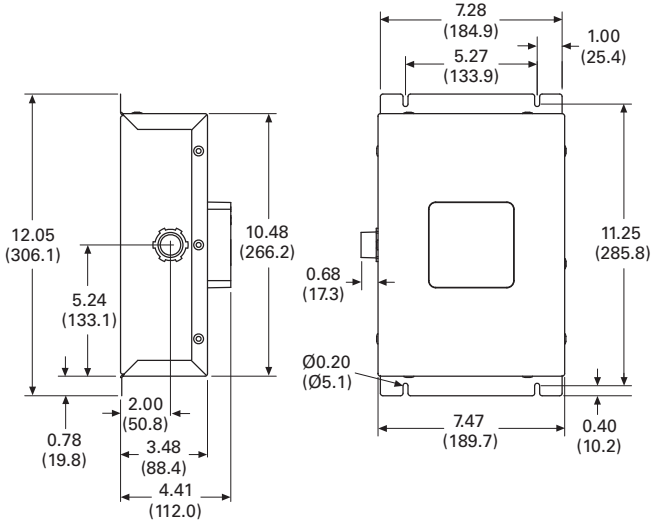

50–200 kA Units in a NEMA 1 Rated Flushmount Enclosure, Weight = 6.8 lbs

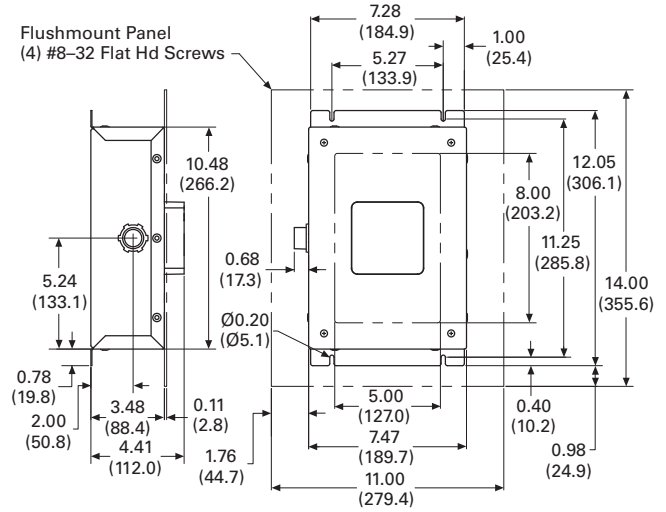

250–400 kA Units in a NEMA 1 Rated Enclosure, Weight = 13.5 lbs

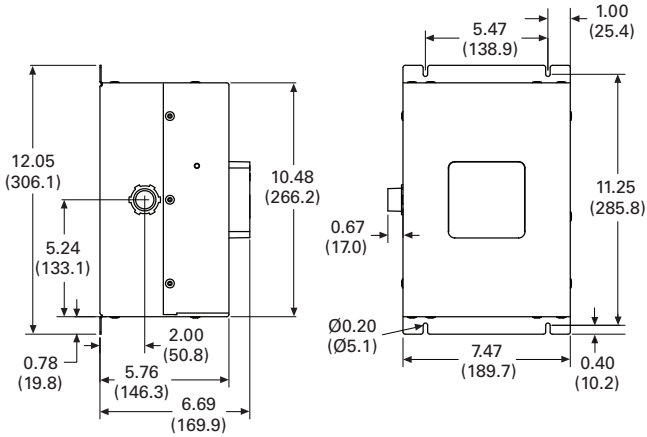

50–400 kA Units in a NEMA 1 Rated Enclosure with Internal Disconnect, Weight = 14.7 lbs

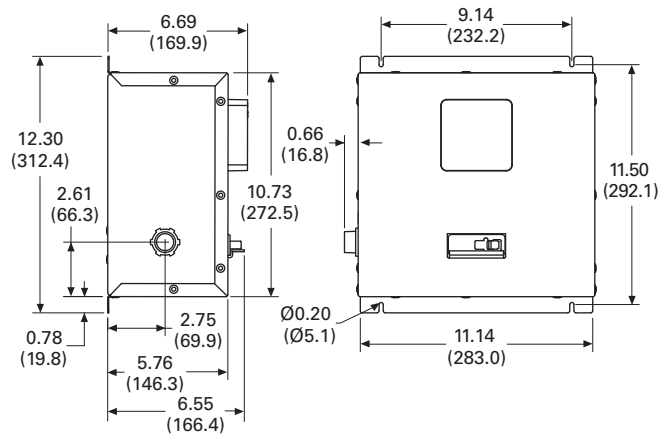

Approximate Dimensions in Inches (mm)

50–200 kA Units in a NEMA 4 or 4X Rated Enclosure, Weight = 14.6 lbs

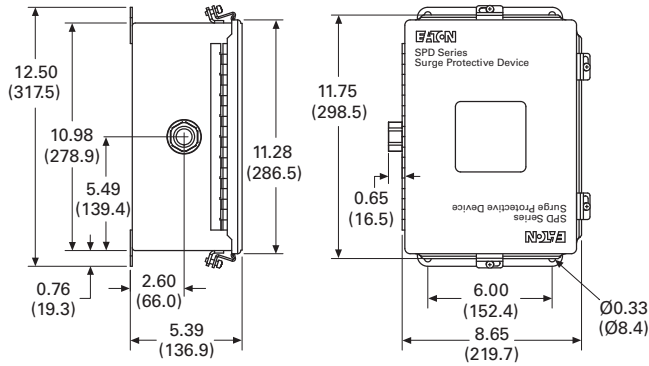

50–400 kA Units in a NEMA 4 or 4X Rated Enclosure with Internal Disconnect, Weight = 27.5 lbs

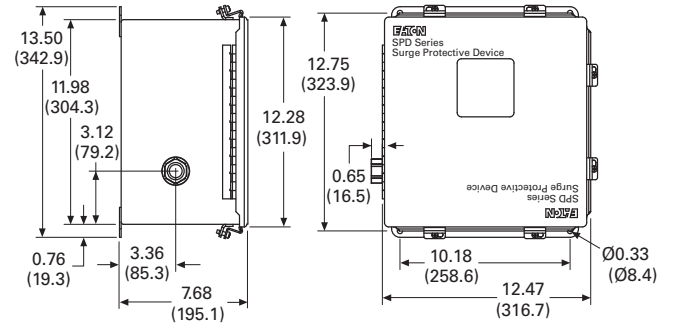

250–400 kA Units in a NEMA 4 or 4X Rated Enclosure, Weight = 14.6 lbs

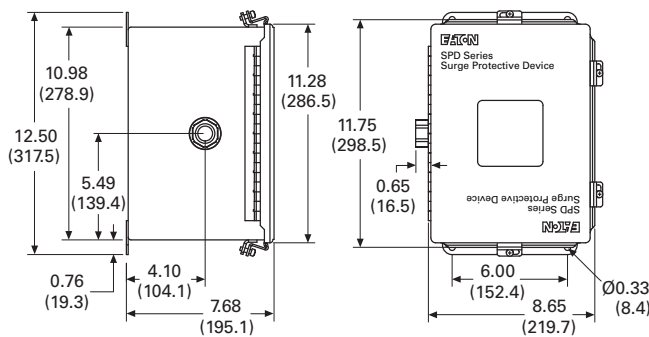

SPV

2



SPV Surge Protective Device

Product Description

Eaton's SPV series is a commercial grade and light industrial surge protective device (SPD) that combines surge suppression components and EMI/RFI filtering, providing effective protection for sensitive electronic loads. Surges (also known as transients), due to lightning, utility grid switching, switching of external/internal inductive or capacitive loads, and other sources, travel on power line conductors throughout the electrical distribution system, causing system operating problems and equipment downtime. Use of the SPV units can prevent these costly occurrences and equipment damage. Available with six surge current capacity ratings, the SPV can be installed on the main of light commercial buildings, on any subpanel in a facility and in any control panel to protect sensitive electronic equipment.

Application Description

The ever-increasing use of microprocessors and other sensitive electronic equipment has increased the necessity for facility-wide surge protection. These sensitive electronic components are used within

many pieces of equipment, including computers, programmable logic controllers, and other commonly used electrical and electronic equipment. Surges can wreak havoc on equipment, causing catastrophic failures, process interruptions and premature aging leading to failure. The application of SPDs can mitigate problems with sensitive electronic equipment, keeping the equipment and the related processes up and running reliably without disruption or damage due to surge-related events.

In addition to externally generated surge events, such as lightning and grid switching, equipment is also susceptible to damage by internally generated surges. In fact, the majority of surges are generated internally by commonly used items, such as fluorescent lighting ballasts, light dimmers, photocopiers, fax machines and variable frequency drives. This further reinforces the necessity for facility-wide surge protection applied at all stages of the electrical distribution system, from the electrical service entrance down to the single-phase loads.

Contents

Description

	<i>Page</i>
Introduction	V3-T2-2
Product Overview	V3-T2-5
SPD Series for Integration into Electrical Distribution Equipment	V3-T2-7
SPD Series for Mounting External to Electrical Distribution Equipment	V3-T2-11
SPV Surge Protective Device Catalog Number Selection	V3-T2-17
Technical Data and Specifications	V3-T2-17
Dimensions	V3-T2-17
CVX050/100	V3-T2-18
SP1 Surge Protective Device	V3-T2-21
SP2 Surge Protective Device	V3-T2-23
AEgis Powerline Filters	V3-T2-25
Sag Ride-Through (SRT)	V3-T2-30
Electronic Voltage Regulator (EVR)	V3-T2-36

Features

- SurgePlane™ technology to ensure reliability and performance by using a low impedance copper platform
- Compact design to enable close mounting to electrical distribution equipment
- Parallel hybrid filter technology
- Individually fused surge suppression components
- Status indicator lights to monitor supply power, surge suppression component status and fusing
- Can be remotely monitored using Form C contacts
- Audible alarm
- Ideal for OEM panel applications
- 50 through 200 kA surge current capacity ratings
- Contains no replaceable parts or items that require periodic maintenance
- 10-year warranty

Eaton is the leading supplier of power protection technology to a number of Fortune 500 companies. We have applied our extensive experience in power quality and have included a number of innovative features in the development of the Eaton SPV series.

Standards and Certifications

- UL 1449 3rd Edition Listed
- UL 1283 Listed
- CSA TIL I-11B
- CSA C22.2 No.8



Catalog Number Selection

SPV

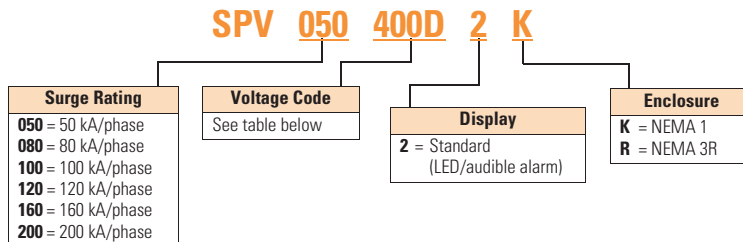

SPV Voltage Codes

Nominal Voltages (Use These Codes to Complete the Model Number)	Voltage Code		
	120/208 240V	230/400 499V ①	277/480 480V
120/240 single/split-phase (3W plus G)	240S	—	—
Three-phase wye (4W plus G)	208Y	400Y	480Y
Three-phase delta (3W plus G)	240D	400D	480D

Technical Data and Specifications

SPV

Description	SPV050	SPV080	SPV100	SPV120	SPV160	SPV200
Surge current per phase	50 kA	80 kA	100 kA	120 kA	160 kA	200 kA
Surge current per mode	25 kA	40 kA	50 kA	60 kA	80 kA	100 kA
Filter attenuation (MIL-STD-220A at 100 kHz)	0–40 dB	0–40 dB	0–40 dB	0–40 dB	0–40 dB	0–40 dB
Circuit construction	Surge-Plane	Surge-Plane	Surge-Plane	Surge-Plane	Surge-Plane	Surge-Plane
UL 1449 3rd Edition Listed	Yes	Yes	Yes	Yes	Yes	Yes
UL 1283 Listed	Yes	Yes	Yes	Yes	Yes	Yes
Nominal discharge current (I _n) ②	20 kA	20 kA	20 kA	20 kA	20 kA	20 kA
cUL Listed	Yes	Yes	Yes	Yes	Yes	Yes
Enclosure						
NEMA 1	Standard	Standard	Standard	Standard	Standard	Standard
NEMA 3R	Optional	Optional	Optional	Optional	Optional	Optional
Short-circuit current rating (SCCR) ③	42 kA	42 kA	42 kA	42 kA	42 kA	42 kA
Warranty	10 years	10 years	10 years	10 years	10 years	10 years

Physical Specifications

Description	Specification
Operating temp range	–40°C to +60°C
Altitude	< 13,000 ft (4000m)
Dimensions	5.00 x 11.55 x 2.60 inches (127.0 x 293.4 x 66.0 mm)
Weight	3.5 lbs (1.6 kg)

Dimensions

Approximate Dimensions in Inches (mm)

SPV—NEMA 1

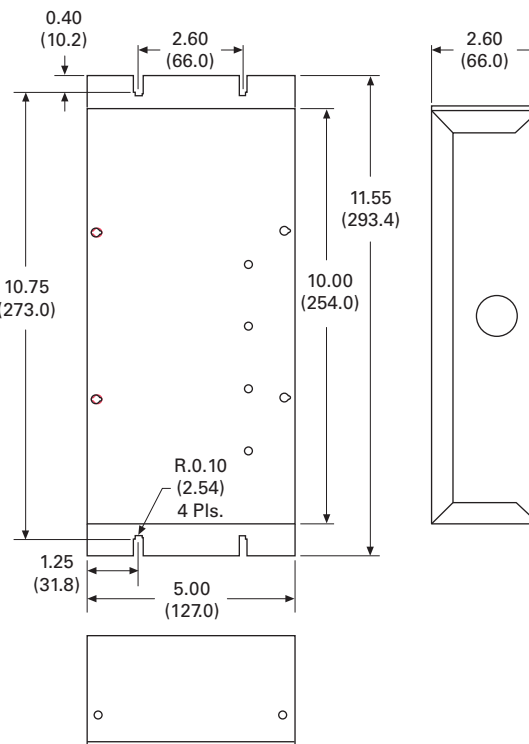

Notes

- ① Contact factory for other configurations: Applicable for 220/380 and 240/415 system voltages.
- ② 208Y, 240S, 240D, 400Y and 480Y units rated 10 kA I_n.
- ③ 5 kA SCCR for 400D and 480D.

CVX050/100



Contents

Description	Page
Introduction	V3-T2-2
Product Overview	V3-T2-5
SPD Series for Integration into Electrical Distribution Equipment	V3-T2-7
SPD Series for Mounting External to Electrical Distribution Equipment	V3-T2-11
SPV Surge Protective Device	V3-T2-16
CVX050/100	
Catalog Number Selection	V3-T2-19
Technical Data and Specifications	V3-T2-19
Dimensions	V3-T2-20
SP1 Surge Protective Device	V3-T2-21
SP2 Surge Protective Device	V3-T2-23
AEGLIS Powerline Filters	V3-T2-25
Sag Ride-Through (SRT)	V3-T2-30
Electronic Voltage Regulator (EVR)	V3-T2-36

CVX050/100

Product Description

With over two decades of experience in the surge suppression industry and extensive R&D initiatives, Eaton is considered a world leader in surge protective device (SPD) manufacturing. All of Eaton's products are manufactured in an ISO® 9001:2000 and ISO 14001 certified facility.

Eaton's CVX050/100 models are rugged, cost-effective, high-quality SPDs that feature self-protected MOVs that eliminate the failure characteristics of standard metal oxide varistors. This technology results in a fail-safe device that monitors the status of the metal oxide disk and disconnects itself from the power system when the disk is approaching breakdown.

The CVX050/100 is easy to install adjacent or even internal to electrical equipment. When installing an SPD in a retrofit environment, it is important to mount the device as close to the electrical equipment as possible. Keep the wiring (lead length) between the electrical equipment and SPD as short as possible, and twist or wire tie the conductors together to reduce the wire's impedance factor.

Application Description

Eaton's CVX050 and CVX100 SPDs protect electronic equipment from damaging transients. These units are suitable for medium and low exposure level applications that require cost-effective, high quality system protection including:

- Residential/small business
- Light industrial
- Light commercial
- Branch panel protection
- OEM applications

Features, Benefits and Functions

- Advanced surge path technology for high fault current capacity, low impedance, high frequency design
- Rugged NEMA® 4X (IP65) enclosure
- Large diameter, self-protected metal oxide varistors provide long life and fail-safe operation
- LED monitoring of each phase
- Wide range of voltage applications from 100 to 600 Vac and 48 and 125 Vdc
- 5-year free replacement warranty

Optional Features

- External mounting feet

Standards and Certifications

- UL 1449 3rd Edition for surge protective devices
- CE marked
- Vibration tested IEC 60255-21-1 and -2



Note: CE, CSA and UL on AC unit only.

Catalog Number Selection

CVX050/100

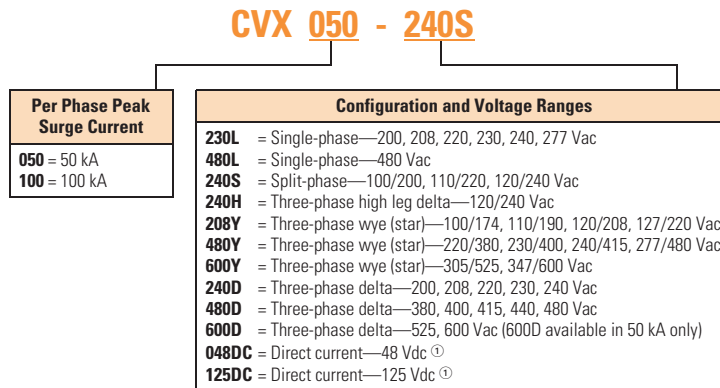

Technical Data and Specifications

CVX050/100 Model Specifications

Description	Specification
Peak kA per phase	50, 100
Peak kA per mode	50
Nominal discharge current	20 kA ①
Short-circuit current rating	100 kA
Single-phase voltages	200, 208, 220, 230, 240, 277, 380, 400, 440, 460, 480 Vac
Split-phase voltages	100/200, 110/220/ 120/240 Vac
High leg delta voltages	240 Vac
Wye system voltages	100/175, 110/190, 120/208, 127/220, 220/380, 230/400, 240/415, 277/480, 305/525, 347/600 Vac
Delta system voltages	200, 208, 220, 230, 240, 380, 400, 415, 440, 480, 525, 600 Vac
Direct current Voltage ②	48 Vdc, 125 Vdc
Input power frequency	47–420 Hz (50/60 Hz typical)
Protection modes	Single-phase: L-N, N-G, L-G Split-phase: L-N, N-G, L-G, L-L High leg delta: L-N, N-G, L-G, L-L, H-N, H-G, H-L Wye: L-N, N-G, L-G, L-L Delta: L-G, L-L Direct current ① (DC): L-L, L-G
Number of ports	1
Specific energy	100 kJ/Ohm
Weight	≈2.0 lbs (1.0 kg)
Operating temperature	–13°F (–25°C) to +140°F (+60°C)
Vibration tested	IEC 60255-21-1 and IEC 60255-21-2

Notes

- ① 480L, 600D and 600Y units rated 10 kA I_n.
- ② DC models only available in 50 kA.

2.1

SPD, Power Conditioning, PF Capacitors and Harmonic Filters

Surge Protection and Power Conditioning

CVX050/100 Voltage Ratings

2

Model	System Configuration	Nominal System Voltage	MCOV				UL 1449-3 VPR ^①			
			L-L	L-N	L-G	N-G	L-L	L-N	L-G	N-G
CVX050										
230L	Single-phase two-wire + ground	200, 208, 220, 230, 240, 277	—	320	640	320	—	1200	1200	1200
480L	Single-phase two-wire + ground	380, 400, 440, 460, 480	—	550	1100	550	—	1800	4000	1800
240S	Split-phase three-wire + ground	100/200, 110/220, 120/240	300	150	300	150	1200	700	1200	800
208Y	Three-phase wye (star) four-wire + ground	100/175, 110/190, 120/208, 127/220	300	150	300	150	1200	700	1200	800
480Y	Three-phase wye (star) four-wire + ground	220/380, 230/400, 240/415, 277/480	640	320	640	320	2500	1200	2000	1200
600Y	Three-phase wye (star) four-wire + ground	305/525, 347/600	840	420	840	420	2500	1500	2500	1500
240D	Three-phase delta three-wire + ground	200, 208, 220, 230, 240	640	—	320	—	2000	—	1200	—
240H	Three-phase high leg delta	240	300	150	150	640	1500	700	1200	700
480D	Three-phase delta three-wire + ground	380, 400, 415, 440, 480	1100	—	550	—	3000	—	1800	—
600D	Three-phase delta three-wire + ground	525, 600	1100	—	700	—	3000	—	2500	—
048DC	Direct current	48 Vdc ^②	130	—	65	—	—	—	—	—
125DC	Direct current	125 Vdc ^②	288	—	144	—	—	—	—	—
CVX100										
230L	Single-phase two-wire + ground	200, 208, 220, 230, 240, 277	—	320	320	320	—	1200	1200	1200
480L	Single-phase two-wire + ground	380, 400, 440, 460, 480	—	550	550	550	—	1800	1800	1800
240S	Split-phase three-wire + ground	100/200, 110/220, 120/240	300	150	150	150	1200	700	800	700
208Y	Three-phase wye (star) four-wire + ground	100/175, 110/190, 120/208, 127/220	300	150	150	150	1000	600	700	700
480Y	Three-phase wye (star) four-wire + ground	220/380, 230/400, 240/415, 277/480	640	320	320	320	1800	1200	1200	1200
600Y	Three-phase wye (star) four-wire + ground	305/525, 347/600	840	420	420	420	2500	1500	1500	1500
240D	Three-phase delta three-wire + ground	200, 208, 220, 230, 240	640	—	320	—	1800	—	1200	—
240H	Three-phase high leg delta	240	300	150	150	150	1200	700	700	700
480D	Three-phase delta three-wire + ground	380, 400, 415, 440, 480	1100	—	550	—	3000	—	1800	—

Dimensions

Approximate Dimensions in Inches (mm)

CVX050/100 Standard Dimensions

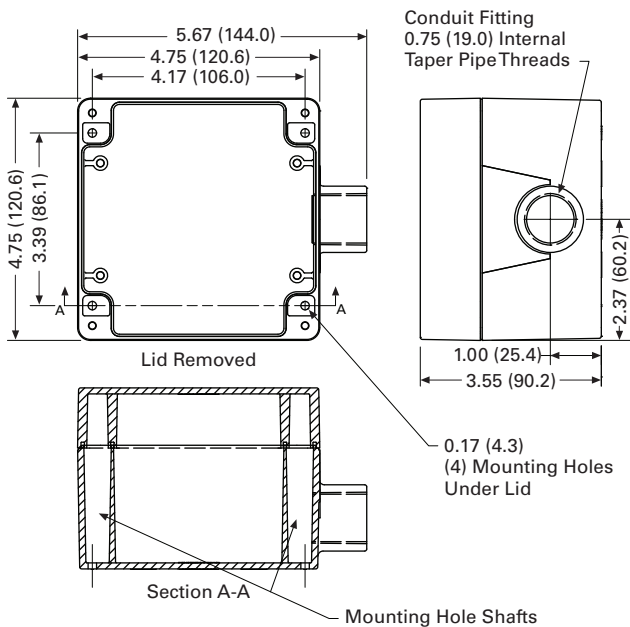

Dimensions are in Inches (mm)

Notes

- ^① UL 1449 3rd Edition VPR (voltage protection rating) test environment: All tests performed with 6-inch lead length, positive polarity.
- ^② DC units available in 50 kA only. Voltages shown are the maximum suggested operating voltages and are not UL certified.

SP1 Surge Protective Device



SP1 Surge Protective Device

Product Description

Eaton's SP1 is a UL 1449 3rd Edition-listed surge protective device that provides reliable, cost-effective surge protection. This Type 1 SPD is capable of being installed on either the line or the load side of the service entrance disconnect, and can be used as a replacement for devices formerly known as secondary surge arresters or lightning arresters, which could not be manufactured after UL 1449 3rd Edition went into effect on September 29, 2009. The unit is available in many common voltages and configurations. Multiple mounting options coupled with a compact footprint enables installation of the SP1 in a wide range of applications, including panelboards, loadcenters, pump panels, control cabinets, and other electrical assemblies and applications.

Installation and operation of the SP1 is simple. The unit comes pre-wired with 24.00 inches of 10-gauge wire and is mounted via the half-inch nipple that is molded into its enclosure. Wall or DIN rail mounting can also be accomplished with the addition of an optional kit. When powered, the unit's light-emitting diode (LED) indicator reports the status of the protection elements and is active when all of them are intact and providing protection. Any loss of protection is signaled when the LED extinguishes.

Contents

Description

	<i>Page</i>
Introduction	V3-T2-2
Product Overview	V3-T2-5
SPD Series for Integration into Electrical Distribution Equipment	V3-T2-7
SPD Series for Mounting External to Electrical Distribution Equipment	V3-T2-11
SPV Surge Protective Device	V3-T2-16
CVX050/100	V3-T2-18
SP1 Surge Protective Device	
Catalog Number Selection	V3-T2-22
Technical Data and Specifications	V3-T2-22
Dimensions	V3-T2-22
SP2 Surge Protective Device	V3-T2-23
AEGIS Powerline Filters	V3-T2-25
Sag Ride-Through (SRT)	V3-T2-30
Electronic Voltage Regulator (EVR)	V3-T2-36

Features

- Type 1 SPD capable of installation on either the line or the load side of the service entrance disconnect
- 20 kA nominal discharge current rating (I_n) on most models
- 50 kA per phase surge current capacity
- Compact footprint—4.80-inch L x 2.90-inch W x 2.50-inch D
- Pre-wired with 24.00 inches of 10-gauge wire
- Half-inch nipple molded into enclosure enables quick and easy mounting
- Optional kit enables wall or DIN rail mounting
- Two-year warranty

Standards and Certifications

- UL 1449 3rd Edition-listed device



Catalog Number Selection

SP1

SP1 - XXXX

Series	Voltage Code
050 = 50 kA	240S = 120/240V single split-phase
100 = 100 kA	208Y = 120/208 wye
	480Y = 277/480 wye
	600Y = 347/600Y wye
	240D = 240 delta
	480D = 480 delta
	600D = 600 delta

SP1MNTGKIT = optional wall or DIN rail mounting kit
(order separately—not included with SP1 unit)

Technical Data and Specifications

SP1

Description	Ratings
Surge current capacity per phase	50 kA
Nominal discharge current (I _n)	20 kA for SP1-240S, 208Y, 480Y, 240D and 480D 10 kA for SP1-600Y and 600D
Short-circuit current rating (SCCR)	200 kA
SPD type	Type 1 (can also be used in Type 2 applications)
System voltages available (Vac)	
Single split-phase	120/240
Three-phase wye	120/208, 277/480, 347/600
Three-phase delta	240, 480, 600
Protection modes	
Single split-phase and three-phase wye	L-N, L-L
Three-phase delta	L-G, L-L
Maximum continuous operating voltage (MCOV)	
SP1-240S and SP1-208Y	150 L-N, 300 L-L
SP1-480Y	320 L-N, 640 L-G
SP1-600Y	420 L-N, 840 L-G
SP1-240D	300 L-G, 300 L-L
SP1-480D	640 L-G, 640 L-L
SP1-600D	840 L-G, 840 L-L
Input power frequency	50/60 Hz
Enclosure rating	NEMA 4
Operating temperature	-20°C to 50°C (-4°F to 122°F)
Operating humidity	5–95%, noncondensing
Operating altitude	Up to 16,000 ft (5000m)
Agency certification and approvals	UL 1449 3rd Edition Listed device
Warranty	2 years

Dimensions

Approximate Dimensions in Inches (mm)

SP1

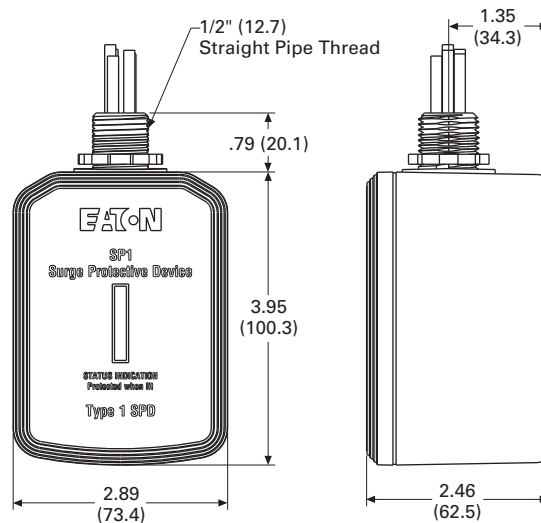

ANSI/UL 1449 3rd Edition Voltage Protection Ratings

Catalog Number	Protection Mode		
	L-N	L-G	L-L
SP1-240S	600	N/A	1000
SP1-208Y	600	N/A	1000
SP1-480Y	1200	N/A	2000
SP1-600Y	1500	N/A	2500
SP1-240D	N/A	1000	1000
SP1-480D	N/A	2000	2000
SP1-600D	N/A	2500	2500

SP2 Surge Protective Device



Surge Protection for Light Commercial and
UL 508A Panel Applications

Contents

Description	Page
Introduction	V3-T2-2
Product Overview	V3-T2-5
SPD Series for Integration into Electrical Distribution Equipment	V3-T2-7
SPD Series for Mounting External to Electrical Distribution Equipment	V3-T2-11
SPV Surge Protective Device	V3-T2-16
CVX050/100	V3-T2-18
SP1 Surge Protective Device	V3-T2-21
SP2 Surge Protective Device Product Selection	V3-T2-24
Technical Data and Specifications	V3-T2-24
Dimensions	V3-T2-24
AEGIS Powerline Filters	V3-T2-25
Sag Ride-Through (SRT)	V3-T2-30
Electronic Voltage Regulator (EVR)	V3-T2-36

SP2 Surge Protective Device

Product Description

The SP2 provides basic surge protection for light commercial electrical systems and OEM equipment requirements. The SP2 is available in the most popular voltage and system configurations and delivers superior surge protection using MOV thermal disconnect technology that eliminates the need for additional overcurrent protection.

Application Description

By providing surge protection, the SP2 can suppress the transients that are prevalent throughout the power distribution system to support reliable operations in applications including:

- HVAC systems
- Control panels
- Automation cabinets
- Pumping systems
- Lighting systems
- Commercial facilities
- Food processing
- Warehouses
- Retail facilities
- Manufacturing operations

Features, Benefits and Functions

- Ease of installation—Compact design allows for easy installation on an electrical panel or meter socket, or integrated into control cabinets
- Type 1 UL 1449 Third Edition listed SP2s are easily selected and installed on the loadside or lineside of the service entrance overcurrent protective device
- Thermal disconnect technology eliminates the need for additional overcurrent protection
- Compact UV-resistant NEMA 4X enclosure for indoor or outdoor applications
- LED status indicators provide surge protection status at a glance—green when good, red to replace
- Voltage-specific models protect electrical systems and equipment, improving performance by more than 110% over “one-size-fits-all” economy surge arresters
- Compact enclosure takes up less space and can be installed in tight spaces
- Can be used on single-phase, split-phase, wye, delta, and high-leg delta systems
- All SP2 devices are individually marked with a serial number for easy tracking and identification
- Two-year warranty

Standards and Certifications

- UL 1449 Third Edition Type 1 SPD File No. E109835, cULus
- Built in an ISO 9001 facility
- Flammability rating UL 94V0
- Designed and tested in accordance with:
 - IEEE C62.41.1
 - IEEE C62.41.2
 - IEEE C62.43-2005
 - IEEE C62.45-2002
 - IEEE C62.48-2005
 - IEEE C62.62-2010



2.1

SPD, Power Conditioning, PF Capacitors and Harmonic Filters

Surge Protection and Power Conditioning

Product Selection

2

SP2

Nominal System Voltage	Maximum Continuous Operating AC Voltage (MCOV)	System Type	Voltage Protection Ratings (VPR)	Connection Points	Catalog Number
120	150	Single-phase, two-wire	700 L-N	2	SP2-120
240	320	Single-phase, two-wire	1200 L-N	2	SP2-240
120/240	150	Split-phase, three-wire	700 L-N, 1200 L-L	3	SP2-240S
240	320	Three-phase delta, three-wire + ground	1200 L-G, 2500 L-L	4	SP2-240D
480	550	Three-phase delta, three-wire + ground	1800 L-G, 3000 L-L	4	SP2-480D
120/208	150	Three-phase wye, three-wire + ground	700 L-G, 1200 L-L	4	SP2-208Y
277/480	320	Three-phase wye, three-wire + ground	1200 L-G, 2500 L-L	4	SP2-480Y
347/600	420	Three-phase wye, three-wire + ground	1500 L-G, 2500 L-L	4	SP2-600Y

Technical Data and Specifications

SP2

Description	Specification
Markets	Light commercial and UL 508A panels
Product warranty	2 years
System types	Single, split, delta, and wye
Nominal system voltage	120, 208, 240, 480, 600 Vac
Installation	Two-, three-, four-wire
Maximum continuous operating AC voltage	Matched to nominal voltage
MCOV	150–550 Vac (see table above)
L-N protection	Yes (single-phase units)
L-L protection	Yes
L-G protection	Yes (three-phase units)
Protection	Surges and transients
SCCR	200 kA
Nominal discharge current (8 x 20 μs) I _n	10 kA
Maximum discharge current (8 x 20 μs) I _{max}	45 kA per phase
Response time t _A	<25 ns
Voltage protection ratings (VPRs)	See table above
Overcurrent device (if required by local code)	Circuit breaker or fuse sized to protect wires per local codes
Frequency	50/60 Hz
Operating status / fault indication	One bi-color LED—green (good) / red (replace)
Conductor gauge/length	10 AWG stranded copper / 18 inches
Mounting	Chase nipple (¾" NPS)
Enclosure rating	NEMA 4X—UL 94-5VA
Degree of protection (installed state)	IP20 (finger-safe)
Install location	Indoor/outdoor
Circuit location	Lineside/loadside
Standards / agency information	UL 1449 Third Edition Type 1 Listed SPD—cULus, RoHS compliant
Operating temperature	–40°C to +65°C
Maximum operating altitude	12,000 feet
Weight	17 oz (476g)

Dimensions

Approximate Dimensions in Inches (mm)

SP2 Enclosure

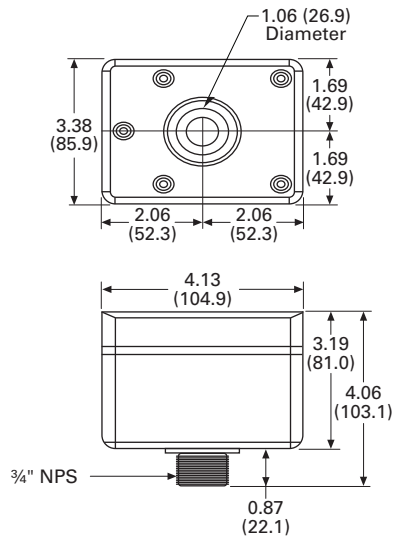

AEGIS Solutions



Contents

<i>Description</i>	<i>Page</i>
Introduction	V3-T2-2
Product Overview	V3-T2-5
SPD Series for Integration into Electrical Distribution Equipment	V3-T2-7
SPD Series for Mounting External to Electrical Distribution Equipment	V3-T2-11
SPV Surge Protective Device	V3-T2-16
CVX050/100	V3-T2-18
SP1 Surge Protective Device	V3-T2-21
SP2 Surge Protective Device	V3-T2-23
AEGIS Powerline Filters	
Features, Benefits and Functions	V3-T2-26
Standards and Certifications	V3-T2-27
Catalog Number Selection	V3-T2-27
Technical Data and Specifications	V3-T2-28
Sag Ride-Through (SRT)	V3-T2-30
Electronic Voltage Regulator (EVR)	V3-T2-36

AEGIS Powerline Filters

Product Description

Eaton AEGIS™ Series line filters and surge protectors are specifically designed to protect sensitive electronics from hazards that exist within a facility. The AEGIS Series hybrid filter reacts instantly to changes in voltage regardless of phase angle or polarity. In comparison to other line filters, this technology provides a higher level of suppression, reliability and life expectancy.

Application Description

By providing surge protection and line filtering, AEGIS devices can suppress the noise and transients prevalent throughout the power distribution system to support reliable operations in applications including:

- Instrumentation
- Water treatment facilities
- Pulp and paper operations
- Refrigeration and heating plants
- Petrochemical and refinery
- Food processing
- Textiles
- Automotive assembly
- Manufacturing operations

No matter where transients originate, the application of AEGIS Series devices will help protect sensitive electronic equipment including:

- Programmable logic controllers (PLCs)
- Scanning devices
- Automatic teller machines (ATMs)
- Cash registers
- Alarm systems
- Microprocessor-controlled
- OEM products
- Robotics
- CAD/CAM systems
- Control equipment
- Medical electronics and devices

AEGIS Series devices are available in a variety of common voltages and configurations.

Why Should Sensitive Electronic Loads be Protected?

PLC manufacturers and service technicians recommend the use of power line filters and surge suppressors to prevent downtime and equipment damage due to surges and electrical line noise. Studies have shown that failure to protect sensitive electronic loads costs American manufacturing and commercial and service industries over \$39 billion per year in lost time and revenue. Preventing these losses is a major cost-saving opportunity.

2.1

SPD, Power Conditioning, PF Capacitors and Harmonic Filters

Surge Protection and Power Conditioning

2

Features, Benefits and Functions

- Compact design with multiple mounting options
- Meets new UL safety standards for surge and filtering protection
- AC models available with up to 80 kA surge current capacity ratings
- DIN rail mounting available on most models
- Contains no replaceable parts or items that require periodic maintenance
- Alarm contact available
- Five- to ten-year warranty standard dependent on model; warranty extended an additional five years if registered

The breadth of the AEGIS Series' features, options and configurations ensures that the correct unit is available for all critical electrical applications, including control panels, security systems, measurement systems, lab equipment and other point-of-use applications.



The AEGIS PH Series Protects Critical Loads up to 20A



The AEGIS PV Series Protects Critical Loads up to 5A

AEGIS Summary

Specifications	PH	PV	CF	CN
Voltage	120/240 Vac	120/240 Vac	120/240 Vac 24/48 Vdc	120/240 Vac 24/48 Vdc
Current range	3–20A	1–5A	10–60A	30A
DIN mounting	Yes	Yes	Yes ①	No
UL 1283 5th Edition & UL 1449 3rd Edition	Yes	Yes	Yes ②	Yes ②
Filtering	Yes	Yes	Yes	No
EMI/RFI filtering attenuation at 100 kHz	75 dB	50 dB	40 dB	N/A
L to G, L to N & N to G protection modes	Yes	Yes	Yes	Yes
Peak kA per phase / mode	60/30	40/20	80/40	80/40
UL nominal discharge current (I _n)	5 kA	5 kA	5 kA	5 kA
UL voltage protection rating (VPR) L–G / L–N ③	330/400	330/400	500/500	500/500
Short-circuit current rating (SCCR)	5 kA	5 kA	10 kA	10 kA
Alarm contacts	Yes	No	Yes ④	No
Standard warranty / registered warranty (years)	10/15	10/15	5/10	5/10
Communication line protection (UL 497A)	No	No	Yes ④	No

AEGIS PH and PV Series Hybrid Powerline Filters

Three-Wire Design has Normal and Common Mode Protection (L-N, L-G, N-G)

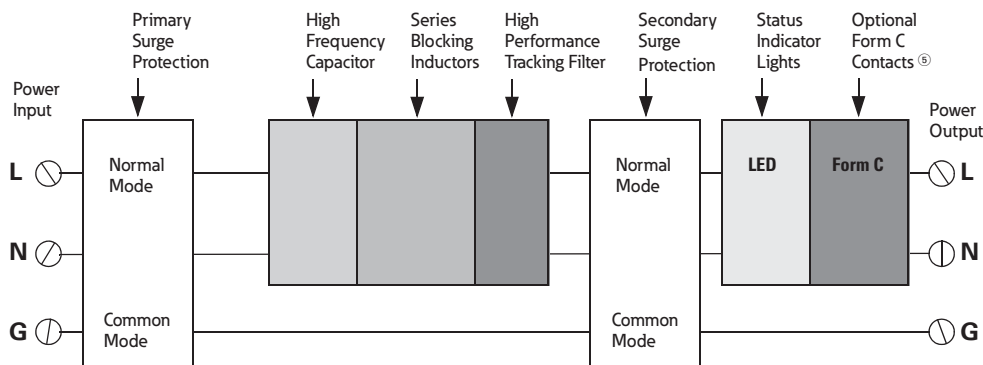

Notes

- ① Optional on 10A and 30A models only.
- ② 120 Vac models only.
- ③ Ratings shown for 120 Vac models, other voltages listed in Technical Data.
- ④ Optional on 30A and 60A models only.
- ⑤ Available on the PH Series only.



AEGIS Products

Standards and Certifications

- UL 1449 Third Edition
- UL 1283 Fifth Edition
- Built in an ISO® 9001 facility
- Designed and tested in accordance with:
 - IEEE® C62.41.1
 - IEEE C62.41.2
 - IEEE C62.43-2005
 - IEEE C62.45-2002
 - IEEE C62.48-2005
 - IEEE C62.62-2010

Catalog Number Selection

AEGIS

AG

Product Family/OEM	Protection/Filtering	Voltage	Amperage	Options
AG	PH = Premium hybrid protection with filtering PV = Premium protection with filtering CF = Critical protection with filtering CN = Critical protection without filtering	120 = 120 Vac 240 = 240 Vac 120 = 120 Vac 240 = 240 Vac 120 = 120 Vac 240 = 240 Vac 024 = 24 Vdc 048 = 48 Vdc 120 = 120 Vac 240 = 240 Vac 024 = 24 Vdc 048 = 48 Vdc	03 = 3A 05 = 5A 10 = 10A 15 = 15A 20 = 20A 01 = 1A 03 = 3A 05 = 5A 10 = 10A 30 = 30A 60 = 60A 30 = 30A	DIN mount standard DIN mount standard DIN = DIN mount ① CP = Compact ② RJ = Telcom protection and Form C status contacts ③

Notes

- ① Only available for 10A CF version.
- ② Only available for 10A, 120V CF version.
- ③ Only available for 30A and 60A CF version.

2.1

SPD, Power Conditioning, PF Capacitors and Harmonic Filters

Surge Protection and Power Conditioning

Technical Data and Specifications

2

AEGIS PH and PV

Specifications	PH 120 Vac	PH 240 Vac	PV 120 Vac	PV 240 Vac
	3, 5, 10, 15, 20A	3, 5, 10, 15, 20A	1, 3, 5A	1, 3, 5A
DIN mounting	Yes	Yes	Yes	Yes
UL 1283 5th Edition and UL 1449 3rd Edition	Yes	Yes	Yes	Yes
Filtering	Yes	Yes	Yes	Yes
EMI/RFI filtering attenuation at 100 kHz	75 dB	75 dB	50 dB	50 dB
L-G, L-N and N-G protection modes	Yes	Yes	Yes	Yes
Peak kA per phase/mode	60/30	60/30	40/20	40/20
UL nominal discharge current (I _n)	5 kA	5 kA	5 kA	5 kA
UL voltage protection rating (VPR) L-G / L-N / N-G	330/400/330	600/700/600	330/400/330	600/700/600
MCOV	150	275	150	275
Short-circuit current rating (SCCR)	5 kA	5 kA	5 kA	5 kA
Alarm contacts	Yes	Yes	No	No
Standard warranty / registered warranty (years)	10/15	10/15	10/15	10/15
Communication line protection (UL 497A)	No	No	No	No

AEGIS CF

Specifications	CF 24 Vdc		CF 48 Vdc		CF 120 Vac			CF 240 Vac				
	10A	10A	10A	10A	10A	10A	30A	60A	10A	10A	30A	60A
DIN mounting	Yes	No	Yes	No	Yes	No	Yes ^①	Yes ^①	Yes	No	No	Yes ^①
UL 1283 5th Edition and UL 1449 3rd Edition	—	—	—	—	Yes	Yes	Yes	Yes	Yes	—	—	—
UL 1283 4th Edition	—	—	—	—	—	—	—	—	—	Yes	Yes	Yes
Filtering	Yes	Yes	Yes	Yes	Yes	Yes	Yes	Yes	Yes	Yes	Yes	Yes
EMI/RFI filtering attenuation at 100 kHz	40 dB	40 dB	40 dB	40 dB	40 dB	40 dB	40 dB	40 dB	40 dB	40 dB	40 dB	40 dB
L-G, L-N and N-G protection modes	Yes	Yes	Yes	Yes	Yes	Yes	Yes	Yes	Yes	Yes	Yes	Yes
Peak kA per phase/mode	6/2	6/2	20/6	20/6	30/10	40/20	80/40	80/40	30/10	24/8	56/24	56/24
UL nominal discharge current (I _n)	N/A	N/A	N/A	N/A	3 kA	5 kA	5 kA	5 kA	3 kA	N/A	N/A	N/A
UL voltage protection rating (VPR) L-G / L-N / N-G	N/A	N/A	N/A	N/A	500/500/500	500/500/500	500/500/500	500/500/500	900/800/900	N/A	N/A	N/A
MCOV	30	30	50	50	150	150	150	150	275	275	275	275
Short-circuit current rating (SCCR)	10 kA	10 kA	10 kA	10 kA	10 kA	10 kA	10 kA	10 kA	10 kA	10 kA	10 kA	10 kA
Alarm contacts	No	No	No	No	No	No	No	No	No	No	No	No
Standard warranty / registered warranty (years)	5/10	5/10	5/10	5/10	5/10	5/10	5/10	5/10	5/10	5/10	5/10	5/10
Communication line protection (UL 497A)	No	No	No	No	No	No	Yes ^①	Yes ^①	No	No	Yes ^①	Yes ^①

Note

^① Optional.

AEGIS CN

Specifications	24 Vdc 30A	48 Vdc 30A	120 Vac 30A	240 Vac 30A
DIN mounting	No	No	No	No
UL 1283 5th Edition and UL 1449 3rd Edition	—	—	Yes	—
UL 1283 4th Edition	—	—	—	Yes
Filtering	No	No	No	No
EMI/RFI filtering attenuation at 100 kHz	N/A	N/A	N/A	N/A
L-G, L-N and N-G protection modes	Yes	Yes	Yes	Yes
Peak kA per phase/mode	20/6	46/20	80/40	56/24
UL nominal discharge current (I _n)	N/A	N/A	5 kA	N/A
UL voltage protection rating (VPR) L-G / L-N / N-G	N/A	N/A	500/500/500	N/A
MCOV	30	50	150	275
Short-circuit current rating (SCCR)	10 kA	10 kA	10 kA	10 kA
Alarm contacts	No	No	No	No
Standard warranty / registered warranty (years)	5/10	5/10	5/10	5/10
Communication line protection (UL 497A)	No	No	No	No

Maximum EMI/RFI Attenuation—MIL-STD-220

Model	10 kHz	100 kHz	1 MHz	10 MHz	100 MHz	Maximum Attenuation Frequency
AGPH120AG	30 dB	74 dB	76 dB	37 dB	36 dB	101 dB at 0.5 MHz
AGPV120AG	27 dB	56 dB	55 dB	36 dB	28 dB	66 dB at 0.085 MHz
AGCF12010-CP	16 dB	35 dB	62 dB	40 dB	50 dB	68 dB at 1.25 MHz
AGCF12010-DIN	16 dB	35 dB	56 dB	29 dB	51 dB	66 dB at 0.7 MHz
AGCF12010	17 dB	35 dB	64 dB	33 dB	51 dB	64 dB at 1.0 MHz
AGCF12030	24 dB	44 dB	58 dB	42 dB	53 dB	67 dB at 0.6 MHz
AGCF12060	20 dB	48 dB	53 dB	29 dB	46 dB	69 dB at 0.4 MHz

Let-Through Voltages Based on IEEE Std. C62.62-2010 Testing Waveforms ①

Test Impulse	AEGIS Series							
	AGPH120AG	AGPV120AG	AGCF12010	AGCF12010-DIN	AGCF12010-CP	AGCF12030AGx	AGCF12060AGx	AGCN12030
IEEE Category A 100 kHz ring wave 6000V, 200A	25V	30V	150V	300V	300V	150V	90V	400V
IEEE Category B 100 kHz ring wave 6000V, 500A	35V	40V	330V	400V	400V	330V	230V	500V
IEEE Category B combination wave 6000V, 3000A (UL 1449-3 VPR)	360V	370V	470V	480V	460V	460V	450V	460V

Note

① All tests conducted on 120 Vac units.

Sag Ride-Through (SRT)

2



Sag Ride-Through (SRT)

Product Description

Eaton's sag ride-through is the first of its kind.

The SRT power conditioner prevents expensive electrical downtime. The SRT represents Eaton's state-of-the-art solution to today's power conditioning challenges.

The Problem—Voltage Sags and Brownouts

The ability of a plant to ride-through voltage sags can have a significant impact on operations and competitiveness. In the United States, voltage sags cost billions of dollars in lost production, interruption, damaged materials, retooling and scrap. In addition, sags can cause: increased operating costs, the need for product reworks, safety hazards, equipment damage and/or failure, reduced product quality, increased clean-up, additional labor costs, increased scrap material and costs associated with investigations into the problem.

Today's industrial and large commercial electricity customers are becoming more sensitive to power disturbances and are demanding better electric quality. However, the quality of power grids is not significantly improving. Customers still experience power quality problems that affect plant operations and profitability.

Deep, Single-Phase Sag

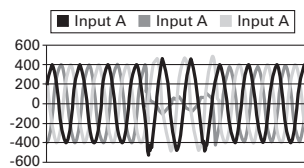

Definition of Voltage Sag

A voltage sag is a sudden, momentary decrease in supply voltage. It can last from a cycle to several seconds. Voltage sags are most often caused by faults on the electrical transmission or distribution system. They can be caused by lightning strikes, animal contact, starting of large motors or an internal fault within a customer's facility.

Contents

Description

Description	Page
Introduction	V3-T2-2
Product Overview	V3-T2-5
SPD Series for Integration into Electrical Distribution Equipment	V3-T2-7
SPD Series for Mounting External to Electrical Distribution Equipment	V3-T2-11
SPV Surge Protective Device	V3-T2-16
CVX050/100	V3-T2-18
SP1 Surge Protective Device	V3-T2-21
SP2 Surge Protective Device	V3-T2-23
AEGIS Powerline Filters	V3-T2-25
Sag Ride-Through (SRT)	
Application Description	V3-T2-31
Features, Benefits and Functions	V3-T2-31
Catalog Number Selection	V3-T2-32
Technical Data and Specifications	V3-T2-33
Dimensions	V3-T2-35
Electronic Voltage Regulator (EVR)	V3-T2-36

Depending on the proximity to the fault, which can be hundreds of miles away, the voltage during the sag is typically 40%–90% of nominal utility voltage. The operation of circuit breakers, fuses and reclosers limits most sags to less than 15 cycles.

Voltage sags are experienced 10 to 20 times more frequently than complete outages. However, voltage sags are equally disruptive to sensitive equipment.

Voltage Sags

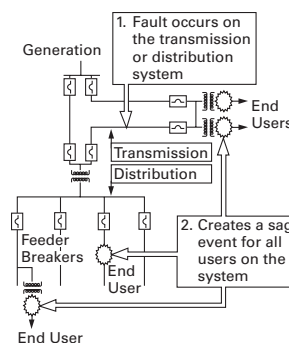

Regularity of Voltage Sags

EPRI conducted a two-year study of power quality levels on distribution systems in the United States. A variation event was recorded every time the voltage dropped below 90% of the nominal. The results are shown below.

A typical distribution system customer experiences about 50 events per year when the voltage drops below 90%, and only about two events per year when the voltage drops below 30% of nominal. The utility study concluded that sags represented almost all of the events experienced at a typical facility.

Events per Year

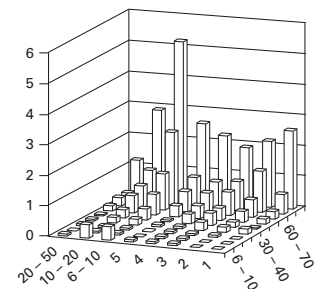

Application Description

Industries and Applications Affected by Sags

Key industries:

- Semi-conductor manufacturers
- Communications
- Steel mills
- Petroleum and chemical processing
- Health care
- Paper mills
- Automotives
- Textile
- Printing
- Plastics
- Other manufacturing

Equipment or processes:

- Manufacturing process controllers
- Variable speed drives
- Robotics
- Motor conductor
- Telephone systems
- HID lighting
- HVAC controls
- Medical equipment
- Computers

Block Diagram of the SRT Active Voltage Conditioner

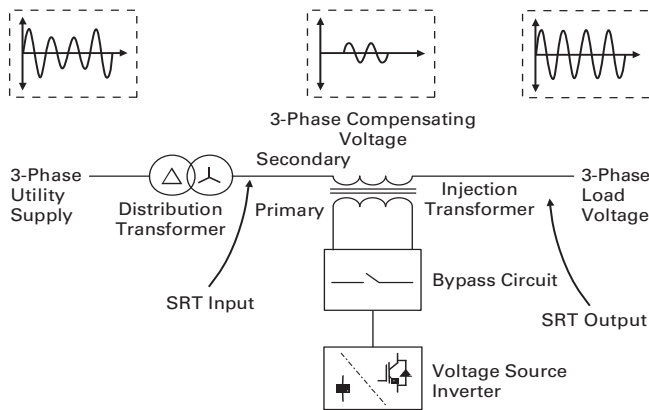

Features, Benefits and Functions

Sag Correction Using the SRT

The SRT is a high performance, inverter-based voltage conditioning device developed to provide protection to sensitive loads against commonly occurring voltage sags.

The SRT monitors the incoming supply voltage and when it deviates from the nominal voltage level, the SRT achieves voltage conditioning by injecting the appropriate correction voltage in series with the power supply. The SRT provides an extremely fast reaction time and subcycle response to sag events that would otherwise cause loads to drop out.

The SRT is designed for low voltage systems (600 to 208, three-phase) and is also offered in medium voltage applications from up to 50 MVA. Installation is simple and the SRT provides customers with a new solution to improve productivity and reduce downtime for sag related problems.

The SRT meets the stringent requirements of the Semi-F47 standard; a key requirement for SAG correction in the semiconductor industry.

- Complete correction of single-phase voltage sags down to 63% for 30 seconds
- Partial correction of three-phase sags down to 50% for 30 seconds
- Correction of utility voltage unbalance (from network side of transformer)
- Attenuation of voltage flicker

Continuous Regulation

The Sag Ride-Through is an active voltage conditioner. This means it will constantly respond to voltage sags and swells in the $\pm 10\%$ range with a regulated output in the $\pm 1\%$ range. The SRT can be applied to the main service entrance, at branch locations or in front critical loads. The SRT provides an outstanding return on investment. It delivers operation productivity that is just not possible with traditional tap switching or ferroresonant technologies. The SRT consists of a voltage source inverter, bypass circuit and an injection transformer connected in series between the incoming utility supply and the load, as shown in the figure below. For the standard sag correcting model, the injection transformer consists of a boost component. The SRT monitors the incoming supply voltage and when it deviates from the nominal voltage level the SRT inserts an appropriate compensating voltage using the IGBT inverter and series injection transformer. Energy is sourced from the supply during this time. This regulates the load voltage to its nominal value, thus eliminating voltage disturbances from the utility supply affecting the load.

2.1

SPD, Power Conditioning, PF Capacitors and Harmonic Filters

Surge Protection and Power Conditioning

Catalog Number Selection

2

SRT2

SRT2 1200 480 A A – TC

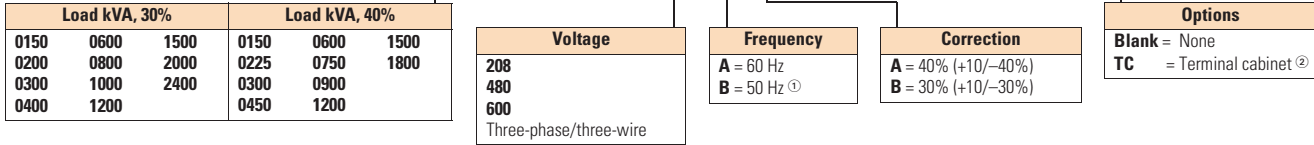

Notes

- ① For 50 Hz international applications, consult factory.
- ② Terminal cabinet required on all units 200 kVA and larger except when a bypass is required.

Technical Data and Specifications

SRT Specifications

Description	Specifications
Load Capacity	
Capacity (kVA)	150 kVA to 50 MVA (as specified per model)
Displacement power factor of connected load	0–1, leading or lagging
Crest factor for rated kVA	2.0 at 100% of rated load for continuous operation (including up to 10% voltage correction)
Overload—30 seconds	150% with up to 10% of voltage correction
Input Supply	
Nominal supply voltage	208/480/600V, 60 Hz three-phase, three-wire plus ground (higher system voltages supplied to requirement up to 36 kV)
Maximum supply voltage	110% of nominal supply voltage
Minimum three-phase supply voltage	
Running	50% of nominal supply voltage
Starting ^①	75% of nominal supply voltage
Minimum single-phase-to-ground supply voltage ^②	
Running	25% of nominal supply voltage
Starting ^①	63% of nominal supply voltage
Efficiency of system	98–99%
Output Supply	
Nominal voltage (V)	208/480/600V, 60 Hz; three-phase, three-wire plus ground (higher system voltages supplied to requirement)
Three-phase balanced correction	+30% for at least 30 seconds for 100% correction
Single-phase-to-ground correction ^②	+45% for at least 30 seconds; +10% continuous three-phase correction (all models). Consult factory for specialist correction requirements.
Voltage regulation	±1% up to 10% continuous three-phase correction ±2.5% at 30% three-phase correction
Response (to sag event)	Initial sag correction applied within 1 ms, remainder over the next cycle
Response to swell event	±1% up to a 10% continuous three-phase correction with initial swell correction applied within 1 ms, remainder over the next cycle
Bypass	
Nominal power	SRT rating (kVA)
Maximum overload capacity (in bypass):	
For 10 minutes (%)	125
For 1 minute (%)	150
For 600 milliseconds (%)	700
For 100 milliseconds (%)	1000
Transfer time ^③	
Inverter to bypass (ms)	<0.5
Bypass to inverter (ms)	<40–750
Environmental	
Operating temperature	32°F to 104°F (0 to 40°C); 122°F (50°C) maximum with 20% load derating
Cooling	Forced ventilation
Capacity derating with elevation	–1.2% every 100m above 1000m
Humidity	<95%, noncondensing
Warranty	1 year

Notes

- ^① If SRT has tripped (offline) due to below threshold input voltages, it cannot be restarted until the system voltage is at least this % of the nominal.
- ^② Single-phase-to-ground fault occurring on the utility side of a delta-wye distribution transformer.
- ^③ The SRT provides continuous correction and only transitions to and from bypass when manually starting and stopping or under fault or overload conditions. The transition from bypass to inverter takes up to 750 ms. The autoresettable bypass mode of operation includes an additional 5-second delay allowing time for the fault to clear.

System Capacities

Model Number	Load Capacity at Normal Voltage 480V (kVA)	Fault Capacity (kVA)	System Efficiency (%)	System Dissipation (Worst Case) (kW)	Airflow (mm ³ /min)
40% Correction					
SRT20150480AA	150	40	97.55	3.8	18
SRT20225480AA	225	40	97.77	5.2	18
SRT20300480AA	300	40	98.00	6.1	18
SRT20450480AA	450	40	98.22	8.0	36
SRT20600480AA	600	40	98.44	9.8	36
SRT20750480AA	750	40	98.44	12.2	54
SRT20900480AA	900	40	98.55	13.2	54
SRT21200480AA	1200	40	98.55	18.1	72
SRT21500480AA	1500	50	98.77	20.22	90
SRT21800480AA	1800	50	98.88	22.11	108
30% Correction					
SRT20150480AB	150	40	98.55	2.85	18
SRT20200480AB	200	40	98.55	3.80	18
SRT20300480AB	300	40	98.66	5.20	18
SRT20400480AB	400	40	98.88	6.10	18
SRT20600480AB	600	40	99.00	8.00	36
SRT20800480AB	800	40	99.11	9.80	36
SRT21000480AB	1000	40	99.11	12.20	54
SRT21200480AB	1200	40	99.33	13.20	54
SRT21500480AB	1500	40	99.22	18.10	72
SRT22000480AB	2000	50	99.33	20.20	90
SRT22400480AB	2400	50	99.44	22.11	108

Dimensions

Approximate Dimensions in Inches (mm)

SRT2, SRT and SRTS

Model Number	Cabinet Dimensions		
	Height	Width	Depth
SRT2 40% Correction			
SRT20150480AA	85.00 (2159.0)	64.00 (1625.6)	32.00 (812.8)
SRT20225480AA	85.00 (2159.0)	64.00 (1625.6)	32.00 (812.8)
SRT20300480AA	85.00 (2159.0)	64.00 (1625.6)	32.00 (812.8)
SRT20450480AA	85.00 (2159.0)	64.00 (1625.6)	32.00 (812.8)
SRT20600480AA	85.00 (2159.0)	64.00 (1625.6)	32.00 (812.8)
SRT20750480AA	85.00 (2159.0)	96.00 (2438.4)	96.00 (2438.4)
SRT20900480AA	85.00 (2159.0)	96.00 (2438.4)	96.00 (2438.4)
SRT21200480AA	85.00 (2159.0)	126.00 (3200.4)	96.00 (2438.4)
SRT21500480AA	85.00 (2159.0)	126.00 (3200.4)	96.00 (2438.4)
SRT21800480AA	85.00 (2159.0)	126.00 (3200.4)	96.00 (2438.4)
SRT2 30% Correction			
SRT20150480AB	85.00 (2159.0)	64.00 (1625.6)	32.00 (812.8)
SRT20200480AB	85.00 (2159.0)	64.00 (1625.6)	32.00 (812.8)
SRT20300480AB	85.00 (2159.0)	64.00 (1625.6)	32.00 (812.8)
SRT20400480AB	85.00 (2159.0)	64.00 (1625.6)	32.00 (812.8)
SRT20600480AB	85.00 (2159.0)	64.00 (1625.6)	32.00 (812.8)
SRT20800480AB	85.00 (2159.0)	64.00 (1625.6)	32.00 (812.8)
SRT21000480AB	85.00 (2159.0)	96.00 (2438.4)	32.00 (812.8)
SRT21200480AB	85.00 (2159.0)	96.00 (2438.4)	32.00 (812.8)
SRT21500480AB	85.00 (2159.0)	126.00 (3200.4)	96.00 (2438.4)
SRT22000480AB	85.00 (2159.0)	126.00 (3200.4)	96.00 (2438.4)
SRT22400480AB	85.00 (2159.0)	126.00 (3200.4)	96.00 (2438.4)

Electronic Voltage Regulator (EVR) Tap Changer

2



Contents

<i>Description</i>	<i>Page</i>
Introduction	V3-T2-2
Product Overview	V3-T2-5
SPD Series for Integration into Electrical Distribution Equipment	V3-T2-7
SPD Series for Mounting External to Electrical Distribution Equipment	V3-T2-11
SPV Surge Protective Device	V3-T2-16
CVX050/100	V3-T2-18
SP1 Surge Protective Device	V3-T2-21
SP2 Surge Protective Device	V3-T2-23
AEGIS Powerline Filters	V3-T2-25
Sag Ride-Through (SRT)	V3-T2-30
Electronic Voltage Regulator (EVR) Catalog Number Selection	V3-T2-37
Technical Data and Specifications	V3-T2-37

Electronic Voltage Regulator (EVR)

Product Description

Eaton’s Electronic Voltage Regulator (EVR) is the ideal solution for keeping your facility and equipment up and running during brownouts, undervoltage conditions and other power problems. The EVR can significantly reduce the costs of equipment damage and downtime when these situations occur. The state-of-the-art design provides rapid response time, high efficiency, high inrush current capability, and operating advantages exclusive to Eaton.

The EVR maintains a tightly regulated output voltage by automatically activating the appropriate transformer tap through a silicone controlled rectifier (SCR). Tap changer response time is initiated at one cycle, ensuring rapid and precise regulation. Switching at zero current enables noise reduction during tap transitions.

Brownouts

In the United States, most facilities have sufficient voltage regulation. However, in some U.S. locations and many developing countries, regulation problems occur because of overstressed utility distribution systems.

In some cases, due to the excessive demand on the utility system, voltage may be below 10% of nominal (–10%) during the day. This condition is called a **voltage regulation or brownout**.

Customers may notice dim lights and reduced power. During the evening, voltage may rise above 10% of nominal (+10%) because large facilities and loads are shut down. This shutdown reduces the power demand on the grid and results in a voltage increase.

The IEEE defines voltage regulation as overvoltage or undervoltage. Voltage regulation events last from **a few minutes to many hours** with voltage varying by $\pm 20\%$. Long-term regulation problems differ from short duration sags and dips, which are much deeper voltage drops.

The Solution

Prior to installing an expensive solution, Eaton encourages customers to monitor incoming voltage to determine if voltage regulation is a problem. The local utility may also be able to provide information on voltage expected at the facility.

Using a meter, it can quickly be determined if a voltage regulation problem or brownout condition exists. The appropriate solution would be an EVR. EVRs can be installed at the service entrance, branch panel or at critical loads.

Eaton’s EVR is a solid-state tap changing power conditioner designed to protect against brownouts and long duration voltage regulation problems.

Features and Benefits

- Coordinated with standard thermal-magnetic breakers to allow motor starts
- Optional 50 kA or 100 kA per phase surge protection
- Input frequency range operation from 57–63 Hz
- Integral manual rotary maintenance bypass switch standard on 50 to 500 kVA units and optional on smaller units
- Not affected by load power factor. Can operate effectively in low-load applications due to “unique leakage reactance” technology
- Fail-safe bypass circuit, isolation transformer and overtemperature protection
- Less than 1% THD
- Optional Standard and Premium metering to monitor voltage, current, frequency, power, energy, PF with minimum and maximum, and communication capabilities

Catalog Number Selection

EVR

EVR **XXX XXXX XXXX X X XX X**

kVA Ratings and Dimensions					
kVA	Weight Lbs	BTUs/hr	Bypass	Metering	Dimensions in Inches (mm) (W x D x H)
010	440	1,025	Optional	No	30.20 x 22.20 x 29.00 (767.1 x 563.9 x 736.6)
010	520	1,205	Optional	Yes	44.20 x 22.20 x 29.00 (1122.7 x 563.9 x 736.6)
015	465	1,540	Optional	No	30.20 x 22.20 x 29.00 (767.1 x 563.9 x 736.6)
015	700	1,540	Optional	Yes	44.20 x 22.20 x 29.00 (1122.7 x 563.9 x 736.6)
025	700	2,560	Optional	Yes	44.20 x 22.20 x 29.00 (1122.7 x 563.9 x 736.6)
030	720	3,090	Optional	Yes	44.20 x 22.20 x 29.00 (1122.7 x 563.9 x 736.6)
045	950	4,600	Optional	Yes	44.30 x 45.90 x 29.00 (1125.2 x 1165.9 x 736.6)
050	1,176	7,332	Yes	Yes	66.00 x 29.00 x 35.50 (1676.4 x 736.6 x 901.7)
075	1,575	9,514	Yes	Yes	76.00 x 34.40 x 35.50 (1930.4 x 873.8 x 901.7)
100	2,014	11,833	Yes	Yes	76.00 x 34.40 x 35.50 (1930.4 x 873.8 x 901.7)
125	2,137	14,748	Yes	Yes	76.00 x 34.40 x 35.50 (1930.4 x 873.8 x 901.7)
150	2,240	17,698	Yes	Yes	76.00 x 34.40 x 35.50 (1930.4 x 873.8 x 901.7)
225	3,300	23,000	Yes	Yes	77.40 x 56.00 x 41.50 (1966.0 x 1422.4 x 1054.1)
300	4,000	30,750	Yes	Yes	77.40 x 56.00 x 41.50 (1966.0 x 1422.4 x 1054.1)
500	5,500	51,250	Yes	Yes	77.00 x 72.40 x 48.40 (1955.8 x 1839.0 x 1229.4)

Nominal Input Voltage (Delta Input: L, L, L, G)
208D = 208
240D = 240
400D = 400
480D = 480
600D = 600

Options
B = Bypass switch ①
M1 = Standard metering (IQ 130)
M2 = Premium metering (IQ 150)

Surge Protection
X = No
S = Yes

Frequency
A = 60 Hz
B = 50 Hz

Nominal Output Voltage (Wye Output: L, L, L, N, G)
208Y = 120/208
400Y = 230/400
480Y = 277/480
600Y = 347/600

Technical Data and Specifications

EVR Specification (10 to 500 kVA)

Feature	Description
Technology	Electronic tap changer
Input voltages	208–600V, three-phase (three-wire)
Input voltage range	+10% to –23% of nominal rated input
Output voltage	±3% of nominal
Response time	1/2 cycle
Frequency	60 Hz, ±3%
Efficiency	97% typical
Line regulation	Output is ±3% of nominal for input variations of +10% to –23% of nominal
Load regulation	Output is maintained within 3% of nominal from no load to full load
Correction time	Output will be corrected to within ±3% of nominal in 1.5 cycles or less
Harmonic distortion	Less than 1.0% added to the output waveform under any dynamic linear loading conditions presented to the line regulator
Noise attenuation	
Common mode	146 dB
Normal mode	3 dB down at 1000 Hz, 40 dB/decade to below 50 dB with resistive load
Turn-on characteristics	When energized, voltage overshoot will be less than 5% of nominal for 1 cycle or less
Overload rating	1000% for 1 cycle and 200% for 10 seconds
Ambient rating	–10° to 40°C
Monitoring	Three green LEDs (phase power on indication), one red LED (alert indication)
Surge protection (optional)	CVX 50 kA SPD device 50 kVA and below, CVX 100 kA SPD device 75 kVA and above
Input breaker	MCCB rated 125% of full rated current
Bypass switch	Normal and bypass selector
Metering (optional)	Standard metering (IQ 130)—voltage and current with minimum and maximum Premium metering (IQ 150)—voltage, current, frequency, power, energy, PF, with minimum and maximum, communications capabilities
Warranty	1-year parts

Notes

① Bypass is standard on 50 kVA and larger units and an option on 45 kVA and smaller units. The 'B' is not included in the part number for units 50 kVA and larger.

All weights are approximate. Monitor option includes main input circuit breaker.

Refer to PAD for pricing and availability.

Capacitor Cell With M12 Threaded Mounting Bolt, Washer, Nut

2



Product Overview

Product Description

Eaton’s power factor correction capacitors and harmonic filters are an essential part of modern electric power systems. Power factor correction capacitors are the simplest and most economical means of increasing the capacity of any power system, minimizing energy losses and correcting load power factor. In addition, power factor penalties can be reduced and power quality can be greatly enhanced.

There are several reasons to correct poor power factor. The first is to reduce or eliminate a power factor penalty charged by the utility. Another reason is that your existing transformer is, or shortly will be, at full capacity and installing power factor correction capacitors can be a very cost-effective solution to installing a brand new service. Depending on the amount of power factor correction (kVAR that needs to be injected into the electrical system to improve the power factor) and the dynamic nature of the load, a fixed or switched capacitor bank may be the best solution.

Contents

Description

	<i>Page</i>
Product Overview	
Product Selection	V3-T2-39
Dimensions	V3-T2-40
UNIPUMP	V3-T2-41
UNIPAK	V3-T2-44
AUTOVAR 300 Automatic Power Factor Correction Capacitor Systems	V3-T2-55
AUTOVAR 600 Automatic Power Factor Correction Capacitor Systems	V3-T2-58
AUTOVAR Filter—LV Automatic Harmonic Filter	V3-T2-63
Transient-Free Static Switching Power Factor Correction Units	V3-T2-67
Active-Harmonic Filter-Harmonic Correction Unit—NEMA 1 Enclosure	V3-T2-71

When capacity becomes a problem, the choice of a solution will be dependent upon the size of the increase needed. Like all power quality solutions, there are many factors that need to be considered when determining which solution will be best to solve your power factor problem.

Harmonic Filtering

As the world becomes more dependent on electric and electronic equipment, the likelihood that the negative impact of harmonic distortion increases dramatically. The efficiency and productivity gains from these increasingly sophisticated pieces of equipment have a negative side effect...increased harmonic distortion in the power lines. The difficult thing about harmonic distortion is determining the cause. Once this has been determined, the solution can be easy. Passive and active harmonic filtering equipment will mitigate specific harmonic issues, and correct poor power factor as well.

Product Selection

1543PCRMA



Capacitor Cell Chart

Voltage	kVAR	Part Number
240	1.5	643PCRMA
240	2	8B43PCRMA
240	2.5	1043PCRMA
240	3	12X43PCRMA
240	4	423PCRMA
240	5	2043PCRMA
240	6.3	6B23PCRMA
240	7.5	7X23PCRMA
240	8.3	8B23PCRMA
240	10	1023PCRMA
240	12.5	12X23PCRMA
240	15	1523PCRMA
240	16.7	16S23PCRMA
240	17.5	17X23PCRMA
480	1.5	1X43PCRMA
480	2	243PCRMA
480	2.5	2X43PCRMA
480	3	343PCRMA
480	4	443PCRMA
480	5	543PCRMA
480	6	643PCRMA
480	7.5	7X43PCRMA
480	8.3	8B43PCRMA
480	9	943PCRMA
480	10	1043PCRMA
480	12.5	12X43PCRMA
480	15	1543PCRMA
480	18	1843PCRMA
480	20	2043PCRMA
480	25	2543PCRMA
480	30	3043PCRMA
600	5	563PCRMA
600	7.5	7X63PCRMA
600	10	1063PCRMA
600	12.5	12X63PCRMA
600	15	1563PCRMA
600	17.5	2063PCRMA
600	20	2563PCRMA

Harmonic Rated Capacitor Cell Chart

Voltage	kVAR	Part Number
240	12.5	12X23PHRMA
480	15.0	1543PHRMA
480	25.0	2543PHRMA
600	12.3	12A63PHRMA
600	14.7	14S63PHRMA
600	16.7	16S63PHRMA

Note

kVAR rating standard. NEMA kVAR tolerance is +15% to 0%. Part number shown is for three-phase units. Up to 5 kVAR at 480V—fast-on terminals are standard. Above 5 kVAR at 480V (and on all other voltages)—sigut terminals are standard. For dimensions and weights, see following page.

Dimensions

Approximate Dimensions in Inches (mm)

Capacitor Cell Chart

Part Number	Depth	Height	Weight in Lbs (kg)
643PCRMA	3.10 (78.7)	7.90 (200.7)	1.1 (0.5)
8B43PCRMA	3.10 (78.7)	9.40 (238.8)	1.3 (0.6)
1043PCRMA	3.10 (78.7)	9.40 (238.8)	1.3 (0.6)
12X43PCRMA	3.50 (88.9)	9.40 (238.8)	1.8 (0.8)
423PCRMA	3.10 (78.7)	7.90 (200.7)	1.1 (0.5)
2043PCRMA	3.50 (88.9)	12.30 (312.4)	2.6 (1.2)
6B23PCRMA	3.10 (78.7)	9.40 (238.8)	1.3 (0.6)
7X23PCRMA	3.10 (78.7)	9.40 (238.8)	1.3 (0.6)
8B23PCRMA	3.50 (88.9)	9.40 (238.8)	1.8 (0.8)
1023PCRMA	3.50 (88.9)	9.40 (238.8)	1.3 (0.6)
12X23PCRMA	3.50 (88.9)	12.30 (312.4)	2.6 (1.2)
1523PCRMA	3.50 (88.9)	12.30 (312.4)	2.6 (1.2)
16S23PCRMA	3.50 (88.9)	15.30 (388.6)	3.3 (1.5)
17X23PCRMA	3.50 (88.9)	15.30 (388.6)	3.3 (1.5)
1X43PCRMA	2.10 (53.3)	5.00 (127.0)	0.7 (0.3)
243PCRMA	2.50 (63.5)	5.50 (139.7)	0.9 (0.4)
2X43PCRMA	2.50 (63.5)	5.50 (139.7)	0.9 (0.4)
343PCRMA	2.50 (63.5)	5.50 (139.7)	0.9 (0.4)
443PCRMA	2.50 (63.5)	6.50 (165.1)	0.9 (0.4)
543PCRMA	2.50 (63.5)	6.50 (165.1)	0.9 (0.4)
643PCRMA	3.10 (78.7)	7.90 (200.7)	1.1 (0.5)
7X43PCRMA	3.10 (78.7)	7.90 (200.7)	1.1 (0.5)
8B43PCRMA	3.10 (78.7)	9.40 (238.8)	1.3 (0.6)
943PCRMA	3.10 (78.7)	9.40 (238.8)	1.3 (0.6)
1043PCRMA	3.10 (78.7)	9.40 (238.8)	1.3 (0.6)
12X43PCRMA	3.50 (88.9)	9.40 (238.8)	1.8 (0.8)
1543PCRMA	3.50 (88.9)	9.40 (238.8)	1.8 (0.8)
1843PCRMA	3.50 (88.9)	12.30 (312.4)	2.6 (1.2)
2043PCRMA	3.50 (88.9)	12.30 (312.4)	2.6 (1.2)
2543PCRMA	3.50 (88.9)	12.30 (312.4)	2.6 (1.2)
3043PCRMA	3.50 (88.9)	15.30 (388.6)	3.3 (1.5)
563PCRMA	3.10 (78.7)	9.40 (238.8)	1.3 (0.6)
7X63PCRMA	3.10 (78.7)	9.40 (238.8)	1.3 (0.6)
1063PCRMA	3.10 (78.7)	9.40 (238.8)	1.3 (0.6)
12X63PCRMA	3.50 (88.9)	9.40 (238.8)	1.8 (0.8)
1563PCRMA	3.50 (88.9)	12.30 (312.4)	2.6 (1.2)
2063PCRMA	3.50 (88.9)	12.30 (312.4)	2.6 (1.2)
2563PCRMA	3.50 (88.9)	15.30 (388.6)	3.3 (1.5)

Harmonic Rated Capacitor Cell Chart

Part Number	Depth	Height	Weight in Lbs (kg)
12X23PHRMA	3.50 (88.9)	15.30 (388.6)	3.3 (1.5)
1543PHRMA	3.50 (88.9)	12.30 (312.4)	2.6 (1.2)
2543PHRMA	3.50 (88.9)	15.30 (388.6)	3.3 (1.5)
12A63PHRMA	3.50 (88.9)	12.30 (312.4)	2.6 (1.2)
14S63PHRMA	3.50 (88.9)	15.30 (388.6)	3.3 (1.5)
16S63PHRMA	3.50 (88.9)	15.30 (388.6)	3.3 (1.5)

Capacitor Cell

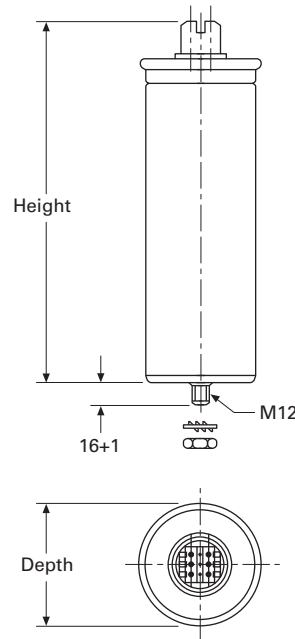

UNIPUMP



UNIPUMP

Product Description

Non-fused capacitors for outdoor irrigation and oil field installations.

- Designed expressly for outdoor pumping applications
- Pole or wall mounting
- Small, light-weight enclosure for easy installation
- SO-WA type flexible cable facilitates installation (4-conductor)
- Gland-type weatherproof bushings
- Strong outer case

Application Description

Outdoor irrigation and oil and gas field pumping.

Features, Benefits and Functions

Configuration

- **Outer case:** Heavy, No. 14 gauge steel finished with durable powder coat finish. Integral strap mounting bracket with keyhole at top for pole or wall installation. No knockouts

Capacitor Cells

- **Terminals:** Insulated finger-safe terminals rated for 3 kVAC withstand
- **Dielectric fill:** Dry-type cells use soft organic polymer resin—Resinol
- Eliminates potential for corona/partial discharge/electrochemical oxidation
- Excellent heat dissipation
- Flash point: +444°F (+229°C)
- Fire point: +840°F (+449°C)

Contents

Description

	<i>Page</i>
Product Overview	V3-T2-38
UNIPUMP	
Product Selection	V3-T2-42
Dimensions	V3-T2-43
UNIPAK	V3-T2-44
AUTOVAR 300 Automatic Power Factor Correction Capacitor Systems	V3-T2-55
AUTOVAR 600 Automatic Power Factor Correction Capacitor Systems	V3-T2-58
AUTOVAR Filter—LV Automatic Harmonic Filter	V3-T2-63
Transient-Free Static Switching Power Factor Correction Units	V3-T2-67
Active-Harmonic Filter-Harmonic Correction Unit—NEMA 1 Enclosure	V3-T2-71

- **Design:** Self-healing metallized high crystalline polypropylene with ramp metallization film. Total losses less than 0.45 watt per kVAR. (Dielectric losses less than 0.2 watt per kVAR)
- **Ramp metallization:** Provides thicker film at higher current density areas, allowing for reduced internal losses, lower operating temperatures and longer life expectancy. Also prevents chain reaction breakdown by limiting propagation of film vaporization
- **Pressure sensitive interrupter:** Built-in, three-phase pop-up interrupter design. UL recognized. Removes capacitor from line before internal pressure can cause case rupture. Bulged capacitor cell top provides easy visual indication of interrupter operation
- **Ceramic discharge resistors:** Reduce residual voltage to less than 50 volts within one minute of de-energization. Selected for 20-year nominal life. Exceeds NEC requirements
- **Capacitor operating temperature:** -40°F (-40°C) to +115°F (+46°C)
- **Case:** Weatherproof aluminum housing
- **Warranty:** The longest in the industry—five full years of warranty on capacitor cells

Standards and Certifications

- UL and CSA listed



2.2

SPD, Power Conditioning, PF Capacitors and Harmonic Filters

Power Factor Correction and Harmonic Filtering

Product Selection

2

UNIPUMP

UNIPUMP



kVAR	Rated Current	Case Size	Cable Size	Shipping Weight in Lbs (kg)	Catalog Number
240 Vac					
2	4.8	AA	14.0	10.0 (4.5)	223JMR
2.5	6.0	AA	14.0	10.0 (4.5)	2X23JMR
3	7.2	AA	14.0	10.0 (4.5)	323JMR
4	9.6	AA	14.0	11.0 (5.0)	423JMR
5	12.0	AA	14.0	11.0 (5.0)	523JMR
6	14.4	BB	12.0	15.0 (6.8)	623JMR
7.5	18.0	BB	12.0	15.0 (6.8)	7X23JMR
480 Vac					
2	2.4	AA	14.0	10.4 (4.7)	243JMR
2.5	3.0	AA	14.0	10.4 (4.7)	2X43JMR
3	3.6	AA	14.0	10.4 (4.7)	343JMR
4	4.8	AA	14.0	10.4 (4.7)	443JMR
5	6.0	AA	14.0	10.4 (4.7)	543JMR
6	7.2	AA	14.0	10.6 (4.8)	643JMR
7.5	9.0	AA	14.0	10.6 (4.8)	7X43JMR
10	12.0	AA	14.0	10.8 (4.9)	1043JMR
12.5	15.0	BB	12.0	15.0 (6.8)	12X43JMR
15	18.0	BB	12.0	15.0 (6.8)	1543JMR
17.5	21.0	BB	8.0	15.8 (7.2)	17X43JMR
20	24.0	BB	8.0	16.8 (7.6)	2043JMR
25	30.0	BB	8.0	16.8 (7.6)	2543JMR
600 Vac					
5	4.9	AA	14.0	10.8 (4.9)	563JMR
7.5	7.4	AA	14.0	10.8 (4.9)	7X63JMR
10	9.8	AA	14.0	10.8 (4.9)	1063JMR
12.5	12.3	AA	12.0	15.0 (6.8)	12X63JMR
15	14.7	BB	12.0	15.8 (7.2)	1563JMR
17.5	17.2	BB	8.0	16.8 (7.6)	17X63JMR
20	19.6	BB	8.0	16.8 (7.6)	2063JMR

Dimensions

Approximate Dimensions in Inches (mm)

UNIPUMP

UNIPUMP Dimension Chart

Size Code	A	B	C	D
AA	11.00 (279.4)	14.20 (360.7)	12.60 (320.0)	13.20 (335.3)
BB	14.00 (355.6)	17.10 (434.3)	15.50 (393.7)	16.10 (408.9)

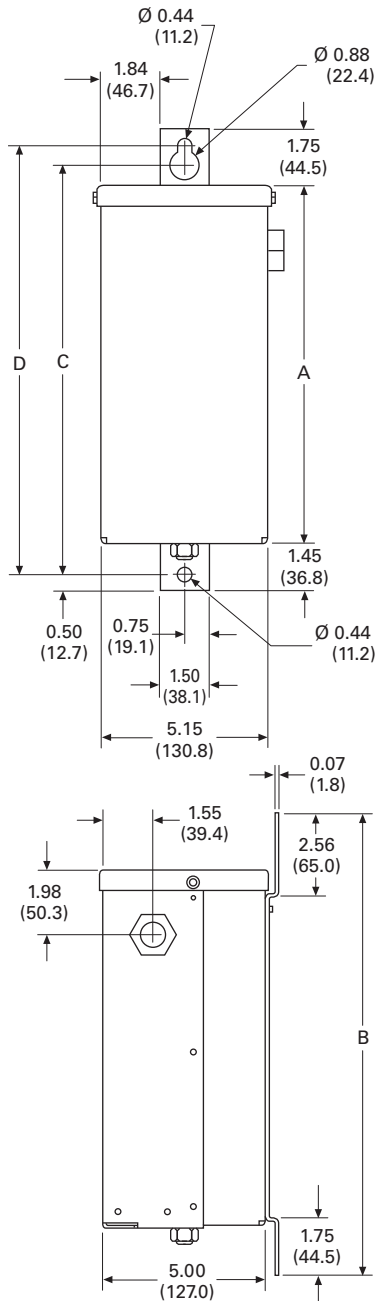

UNIPAK

2

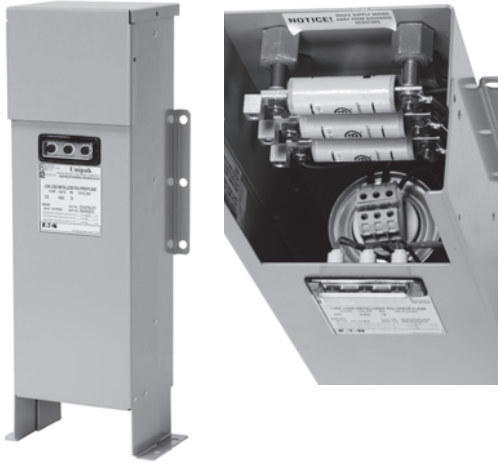

Contents

<i>Description</i>	<i>Page</i>
Product Overview	V3-T2-38
UNIPUMP	V3-T2-41
UNIPAK	
Features, Benefits and Functions	V3-T2-45
Standards and Certifications	V3-T2-45
Product Selection	V3-T2-46
Wiring Diagram	V3-T2-52
Dimensions	V3-T2-53
AUTOVAR 300 Automatic Power Factor Correction Capacitor Systems	V3-T2-55
AUTOVAR 600 Automatic Power Factor Correction Capacitor Systems	V3-T2-58
AUTOVAR Filter—LV Automatic Harmonic Filter	V3-T2-63
Transient-Free Static Switching Power Factor Correction Units	V3-T2-67
Active-Harmonic Filter-Harmonic Correction Unit—NEMA 1 Enclosure	V3-T2-71

UNIPAK

Product Description

UNIPAK Filter—Harmonic Filtering

Harmonic filter systems for low voltage, heavy-duty applications.

- Reduce harmonics and correct power factor
- Tuned for maximum efficiency in reducing harmonic currents associated with nonlinear load environments (such as VFDs)
- Two-enclosure design isolates capacitors from high-temperature operating reactors, and allows for flexible installation
- Twenty-year life design
- Five-year cell warranty/one-year reactor warranty
- Three-phase cell capacitor construction. Three-phase interrupter system

Harmonic Rated Capacitor Cells

- Standard voltage rated capacitor cells designed for higher dielectric strength and with added ability to withstand stress caused by dv/dt voltage transients caused by harmonics
- Better suited for harmonic applications than higher voltage rated cells

UNIPAK with Harmonic Rated Capacitor Cells

- Standard capacitor systems using harmonic rated capacitor cells
- For use in moderate harmonic environments where engineering supervision allows in place of harmonic filter designs
- Provides future conversion capability into a harmonic filter design due to facility growth or increased nonlinear load levels

Application Description

Designed for power factor correction in plants experiencing harmonics problems due to high amounts of nonlinear loads.



UNIPAK with Optional Air Filter

Features, Benefits and Functions

- Five-year warranty on capacitor cells
- Designed for heavy-duty applications
- Twenty-year life design
- Indoor/outdoor service
- Wall (up to 180 kVAR) and floor-mounted units available
- Fuse protection standard
- Blown-fuse indicating lights standard
- Quick lead-times
- Harmonic filters available
- Slim profile allows reduced footprint, conserving valuable floor space
 - New capacitor configuration leads to cooler operating conditions, extending capacitor life
- **Cover:** “L” shaped gasketed cover with multiple fasteners provides front opening for ease of installation and service
- **Ground terminal:** Furnished inside case
- **Power terminal lugs:** Large size provided for easy connection
- **Fusing:**
 - **Size Code A1:** Three midget-type fuses with 100,000 ampere interrupting capacity
 - **Size Code A2 and larger:** Three slotted-blade type fuses with 200,000 ampere interrupting capacity; Fuses mounted on stand-off bushings or fuse blocks; solderless connectors for easy hookup of incoming line conductors

Configuration

- **Outer case:** Heavy, No. 14 gauge steel finished with durable powder coat finish. Wall mounting flanges and floor mounting feet. Elimination of knockouts permits indoor/outdoor use. Manufactured to NEMA requirements 1, 3R and 12
- Elevated floor mounting feet allow access for easy maintenance

Note: NEMA 12 enclosure standard for enclosure sizes A1 to C1.

- **Fuse indicating lights:** Red, neon blown-fuse indicating lights are protected by transparent weatherproof guard
- **Options:**
 - No fuses
 - Air filters for units with enclosure sizes C2, D1 and E1

Capacitor cells

- **Terminals:** Insulated finger-safe terminals rated for 3 kVAC withstand
- **Dielectric fill:** Dry-type cells use soft organic polymer resin—Resinol
 - Eliminates potential for corona/partial discharge/electrochemical oxidation
 - Excellent heat dissipation
 - Flash point: +444°F (+229°C)
 - Fire point: +840°F (+449°C)
- **Design:** Self-healing metallized high crystalline polypropylene with ramp metallization film. Total losses less than 0.45 watt per kVAR. (Dielectric losses less than 0.2 watt per kVAR)
- **Ramp metallization:** Provides thicker film at higher current density areas, allowing for reduced internal losses, lower operating temperatures and longer life expectancy. Also prevents chain reaction breakdown by limiting propagation of film vaporization
- **Pressure sensitive interrupter:** Built-in, three-phase pop-up interrupter design. UL recognized. Removes capacitor from line before internal pressure can cause case rupture. Bulged capacitor cell top provides easy visual indication of interrupter operation
- **Ceramic discharge resistors:** Reduce residual voltage to less than 50 volts within one minute of de-energization. Selected for 20-year nominal life. Exceeds NEC requirements

- **Capacitor operating temperature:** -40°F (-40°C) to +115°F (+46°C)
- **Case:** Weatherproof aluminum housing
- **Warranty:** The longest in the industry—five full years of warranty on capacitor cells

Reactors

- **Tuning:** Tuned to 4.7 harmonic order
- **Detuning:** Reactor designs can be detuned upon request to 4.2nd to protect capacitors against alternate harmonics
- **Construction:** 100% copper windings for cool operating temperatures; designed operating temperature rise less than 80°C. Open frame construction with 220°C insulation system
- **Thermal sensors:** One per phase, self-resetting thermistors provide reactor over-temperature protection and indication
- **Reactor indicating light:** Thermal overload indicating light activates when reactor temperature reaches 180°C
- **Warranty:** One-year replacement of reactors

Standards and Certifications

- UL and CSA listed



Product Selection

2

UNIPAK Low Voltage Fixed Capacitor Banks

UNIPAK

240 Vac UNIPAK



kVAR	Rated Current	Enclosure	Shipping Weight in Lbs (kg)	Part Number
1	2.4	A1	18 (8)	123PMURF
1.5	3.6	A1	18 (8)	1X23PMURF
2	4.8	A1	19 (9)	223PMURF
2.5	6	A1	19 (9)	2X23PMURF
3	7.2	A1	19 (9)	323PMURF
4	9.6	A1	20 (9)	423PMURF
5	12	A2	29 (13)	523PMURF
6	14.4	A2	29 (13)	623PMURF
7.5	18	A2	30 (14)	7X23PMURF
8	19.2	A2	31 (14)	823PMURF
10	24	A2	31 (14)	1023PMURF
12.5	30	A2	32 (14)	12X23PMURF
15	36	A2	33 (15)	1523PMURF
17.5	42	B1	44 (20)	17X23PMURF
20	48	B1	45 (20)	2023PMURF
22.5	54	B1	46 (21)	22X23PMURF
25	60	B1	46 (21)	2523PMURF
30	72	B1	47 (21)	3023PMURF
32.5	78	B1	47 (22)	32X23PMURF
35	84	B1	48 (22)	3523PMURF
40	96	C1	64 (29)	4023PMURF
42.5	102	C1	65 (30)	42X23PMURF
45	108	C1	66 (30)	4523PMURF
50	120	C1	68 (31)	5023PMURF
60	144	C1	69 (31)	6023PMURF
70	168	C2	99 (45)	7023PMURF
75	180	C2	100 (46)	7523PMURF
80	192	C2	101 (46)	8023PMURF
90	216	C2	103 (47)	9023PMURF
100	240	C2	104 (47)	10023PMURF
120	288	D1	133 (60)	12023PMURF
140	336	D1	137 (62)	14023PMURF
150	360	D1	140 (64)	15023PMURF
160	384	E1	175 (80)	16023PMURF
180	432	E1	182 (83)	18023PMURF
200	480	E1	189 (86)	20023PMURF

Notes

Multiply the 240 Vac kVAR rating by 0.75 to calculate the kVAR value at 208 Vac.

Fused with blown-fuse indication available standard. Non-fused and no lights also available—please consult the factory.

Other ratings available, consult factory.

For dimensional information, refer to **Page V3-T2-53**.

Part Numbers:

PMURF—three fuses + three lights

PMURN—non-fused

UNIPAK



480 Vac UNIPAK

kVAR	Enclosure	Rated Current	Shipping Weight in Lbs (kg)	Part Number
1.5	A1	1.8	17 (8)	1X43PMURF
2	A1	2.4	18 (8)	243PMURF
2.5	A1	3	18 (8)	2X43PMURF
3	A1	3.6	19 (9)	343PMURF
4	A1	4.8	19 (9)	443PMURF
5	A1	6	19 (9)	543PMURF
6	A1	7.2	19 (9)	643PMURF
7.5	A1	9	20 (9)	7X43PMURF
8	A1	9.6	20 (9)	843PMURF
9	A1	10.8	20 (9)	943PMURF
10	A1	12	20 (9)	1043PMURF
12.5	A2	15	29 (13)	12X43PMURF
15	A2	18	29 (13)	1543PMURF
17.5	A2	21	30 (14)	17X43PMURF
20	A2	24	31 (14)	2043PMURF
22.5	B1	27	44 (20)	22X43PMURF
25	A2	30	32 (15)	2543PMURF
27.5	B1	33	44 (20)	27X43PMURF
30	B1	36	44 (20)	3043PMURF
32.5	B1	39	45 (20)	32X43PMURF
35	B1	42	45 (20)	3543PMURF
37.5	B1	45	46 (21)	37X43PMURF
40	B1	48	46 (21)	4043PMURF
42.5	B1	51	47 (21)	42X43PMURF
45	B1	54	47 (22)	4543PMURF
50	B1	60	48 (22)	5043PMURF
55	B1	66	48 (22)	5543PMURF
60	B1	72	48 (22)	6043PMURF
65	C1	78	64 (29)	6543PMURF
70	C1	84	65 (30)	7043PMURF
75	C1	90	65 (30)	7543PMURF
80	C1	96	66 (30)	8043PMURF
85	C1	102	68 (31)	8543PMURF
90	C1	108	68 (31)	9043PMURF
100	C1	120	68 (31)	10043PMURF
120	C1	144	68 (31)	12043PMURF
125	C2	150	99 (45)	12543PMURF
140	C2	168	100 (46)	14043PMURF
150	C2	180	101 (46)	15043PMURF
160	C2	192	103 (47)	16043PMURF
180	C2	216	104 (47)	18043PMURF

Notes

Fused with blown-fuse indication available standard.

Non-fused and no lights also available—please consult the factory.

Other ratings available, consult factory.

For dimensional information, refer to **Page V3-T2-53**.

Part Number

PMURF—three fuses + three lights

PMURN—non-fused

UNIPAK



480 Vac UNIPAK, continued

kVAR	Enclosure	Rated Current	Shipping Weight in Lbs (kg)	Part Number
200	D1	240	137 (62)	20043PMURF
225	D1	270	140 (64)	22543PMURF
250	E1	300	170 (77)	25043PMURF
300	E1	360	175 (80)	30043PMURF
350	E1	420	182 (83)	35043PMURF
400	E1	480	189 (86)	40043PMURF

Notes

Fused with blown-fuse indication available standard.

Non-fused and no lights also available—please consult the factory.

Other ratings available, consult factory.

For dimensional information, refer to **Page V3-T2-53**.

Part Number

PMURF—three fuses + three lights

PMURN—non-fused

UNIPAK

600 Vac UNIPAK



kVAR	Enclosure	Rated Current	Shipping Weight in Lbs (kg)	Part Number
5	A1	4.9	19 (9)	563PMURF
7.5	A1	7.4	19 (9)	7X63PMURF
10	A1	9.8	20 (9)	1063PMURF
12.5	A1	12.3	20 (9)	12X63PMURF
15	A2	14.7	29 (13)	1563PMURF
17.5	A2	17.2	29 (13)	17X63PMURF
20	A2	19.6	30 (14)	2063PMURF
22.5	B1	22.1	44 (20)	22X63PMURF
25	A2	24.5	31 (14)	2563PMURF
27.5	B1	27.0	44 (20)	27X63PMURF
30	B1	29.4	45 (20)	3063PMURF
32.5	B1	31.9	45 (20)	32X63PMURF
35	B1	34.3	46 (21)	3563PMURF
37.5	B1	36.8	46 (21)	37X63PMURF
40	B1	39.2	47 (21)	4063PMURF
42.5	B1	41.7	47 (22)	42X63PMURF
45	B1	44.1	48 (22)	4563PMURF
50	B1	49.0	48 (22)	5063PMURF
55	C1	53.9	64 (29)	5563PMURF
60	C1	58.8	64 (29)	6063PMURF
65	C1	63.7	65 (30)	6563PMURF
70	C1	68.6	65 (30)	7063PMURF
75	C1	73.5	66 (30)	7563PMURF
80	C1	78.4	68 (31)	8063PMURF
85	C1	83.3	68 (31)	8563PMURF
90	C1	88.2	68 (31)	9063PMURF
100	C1	98.0	68 (31)	10063PMURF
120	C2	117.6	99 (45)	12063PMURF
125	C2	122.5	100 (46)	12563PMURF
140	C2	137.2	101 (46)	14063PMURF
150	C2	147.0	103 (47)	15063PMURF
160	D1	156.8	135 (61)	16063PMURF
180	D1	176.4	137 (62)	18063PMURF
200	D1	196.0	140 (64)	20063PMURF
225	D1	220.5	143 (65)	22563PMURF
250	E1	245.0	170 (77)	25063PMURF
300	E1	294.0	175 (80)	30063PMURF
350	E1	343.0	182 (83)	35063PMURF
400	E1	392.0	189 (86)	40063PMURF

Notes

Fused with blown-fuse indication available standard. Non-fused and no lights also available—please consult the factory

Other ratings available, consult factory

For dimensional information, refer to **Page V3-T2-53**.

Part Numbers:

PMURF—three fuses + three lights

PMURN—non-fused

UNIPAK—with Harmonic Cells

2

Harmonic Cells

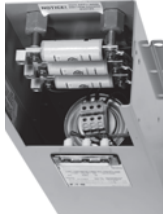

Low Voltage Fixed Capacitor Systems with Harmonic Cells

kVAR	Rated Current	Case Size	Shipping Weight in Lbs (kg)	Catalog Number
240V				
15	36	B1	38.4 (17)	1523HURF
25	60	B1	38.4 (17)	2523HURF
30	72	C1	55.2 (25)	3023HURF
50	120	C1	57.6 (26)	5023HURF
60	144	C2	100.8 (46)	6023HURF
75	180	C2	104.4 (47)	7523HURF
100	240	D1	136.8 (62)	10023HURF
125	300	E1	189.6 (86)	12523HURF
480V				
15	18	A2	25.2 (11)	1543HURF
25	30	B1	37.2 (17)	2543HURF
30	36	B1	38.4 (17)	3043HURF
50	60	B1	39.6 (18)	5043HURF
60	72	C1	52.8 (24)	6043HURF
75	90	C1	55.2 (25)	7543HURF
100	120	C1	57.6 (26)	10043HURF
125	150	C2	100.8 (46)	12543HURF
150	180	C2	104.4 (47)	15043HURF
200	240	D1	136.8 (62)	20043HURF
250	300	E1	186.0 (84)	25043HURF
300	360	E1	189.6 (86)	30043HURF
600V				
15	14.7	B1	37.2 (17)	1563HURF
25	24.5	B1	38.4 (17)	2563HURF
30	29.4	B1	39.6 (18)	3063HURF
50	49	C1	55.2 (25)	5063HURF
60	58.8	C1	57.6 (26)	6063HURF
75	73.5	C2	100.8 (46)	7563HURF
100	98	C2	104.4 (47)	10063HURF
125	122.5	D1	136.8 (62)	12563HURF
150	147	D1	136.8 (62)	15063HURF
200	196	E1	186.0 (84)	20063HURF
250	245	E1	189.6 (86)	25063HURF

Notes

Fused with blown-fuse indication standard.

Other ratings available, consult factory.

UNIPAK Low Voltage Fixed Harmonic Filters

Harmonic Filters



Fixed UNIPAK Harmonic Filters

kVAR	Rated Current	Case Size	Shipping Weight in Lbs (kg)	Reactor Cabinet Case Size	Reactor Shipping Weight in Lbs (kg)	Combined Shipping Weight in Lbs (kg)	Catalog Number
240V							
15	36	B1	48.4 (22.0)	R	90.0 (40.9)	138.4 (62.8)	15232HMURF
25	60	B1	48.4 (22.0)	R	105.0 (47.7)	153.4 (69.6)	25232HMURF
30	72	C1	65.2 (29.6)	R	110.0 (49.9)	175.2 (79.5)	30232HMURF
50	120	C1	67.6 (30.7)	R	130.0 (59.0)	197.6 (89.7)	50232HMURF
60	144	C2	110.8 (50.3)	R	160.0 (72.6)	270.8 (122.9)	60232HMURF
75	180	C2	114.4 (51.9)	R	185.0 (84.0)	299.4 (135.9)	75232HMURF
100	240	D1	146.8 (66.6)	R	240.0 (109.0)	386.8 (175.6)	100232HMURF
125	300	E1	199.6 (90.6)	S	280.0 (127.1)	479.6 (217.7)	125232HMURF
150	360	E1	220.0 (99.9)	S	280.0 (127.1)	500.0 (227.0)	150232HMURF
480V							
15	18	A2	35.2 (16.0)	R	90.0 (40.9)	125.2 (56.8)	15432HMURF
25	30	B1	47.2 (21.4)	R	105.0 (47.7)	152.2 (69.1)	25432HMURF
30	36	B1	48.4 (22.0)	R	110.0 (49.9)	158.4 (71.9)	30432HMURF
50	60	B1	49.6 (22.5)	R	130.0 (59.0)	179.6 (81.5)	50432HMURF
60	72	C1	62.8 (28.5)	R	160.0 (72.6)	222.8 (101.2)	60432HMURF
75	90	C1	65.2 (29.6)	R	185.0 (84.0)	250.2 (113.6)	75432HMURF
100	120	C1	67.6 (30.7)	R	240.0 (109.0)	307.6 (139.7)	100432HMURF
125	150	C2	110.8 (50.3)	R	280.0 (127.1)	390.8 (177.4)	125432HMURF
150	180	C2	114.4 (51.9)	S	280.0 (127.1)	394.4 (179.1)	150432HMURF
200	240	D1	146.8 (66.6)	S	330.0 (149.8)	476.8 (216.5)	200432HMURF
250	300	E1	196.0 (89.0)	T	570.0 (258.8)	766.0 (347.8)	250432HMURF
300	360	E1	199.6 (90.6)	T	575.0 (261.1)	774.6 (351.7)	300432HMURF
600V							
15	14.7	B1	47.2 (21.4)	R	90.0 (40.9)	137.2 (62.3)	15632HMURF
25	24.5	B1	48.4 (22.0)	R	90.0 (47.7)	153.4 (69.6)	25632HMURF
30	29.4	B1	49.6 (22.5)	R	105.0 (49.9)	159.6 (72.5)	30632HMURF
50	49	C1	65.2 (29.6)	R	110.0 (59.0)	195.2 (88.6)	50632HMURF
60	58.8	C1	67.6 (30.7)	R	130.0 (72.6)	227.6 (103.3)	60632HMURF
75	73.5	C2	110.8 (50.3)	R	160.0 (84.0)	295.8 (134.3)	75632HMURF
100	98	C2	114.4 (51.9)	R	185.0 (109.0)	354.4 (160.9)	100632HMURF
125	122.5	D1	146.8 (66.6)	S	240.0 (127.1)	426.8 (193.8)	125632HMURF
150	147	D1	146.8 (66.6)	S	280.0 (127.1)	426.8 (193.8)	150632HMURF
200	196	E1	196.0 (89.0)	T	330.0 (149.8)	526.0 (238.8)	200632HMURF
250	245	E1	199.6 (90.6)	T	570.0 (258.8)	769.6 (349.4)	250632HMURF

Notes

Other ratings available, consult factory.

Fused with blown-fuse indication standard.

Wiring Diagram

Filter Schematic with Wiring Interconnects

2

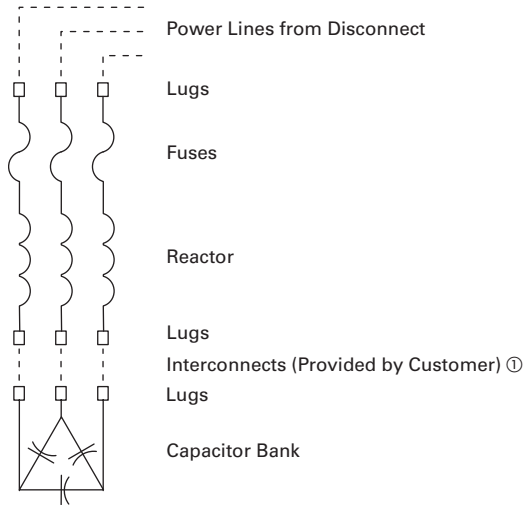

Note

① Refer to NEC.

Dimensions

Approximate Dimensions in Inches (mm)

Reactor Cabinet

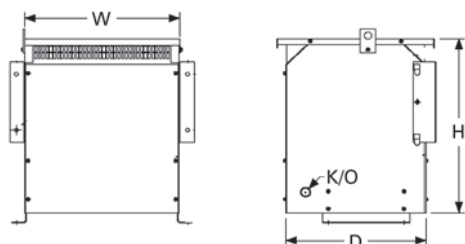

Reactor Cabinet

Case Size	Height	Width	Depth
R	24.75 (628.7)	20.00 (508.0)	18.13 (460.5)
S	25.00 (635.0)	24.25 (616.0)	20.25 (514.4)
T	31.00 (787.4)	25.00 (635.0)	32.75 (831.9)

Low Voltage Fixed Capacitor Banks and Fixed Harmonic Filters

Case A1, A2

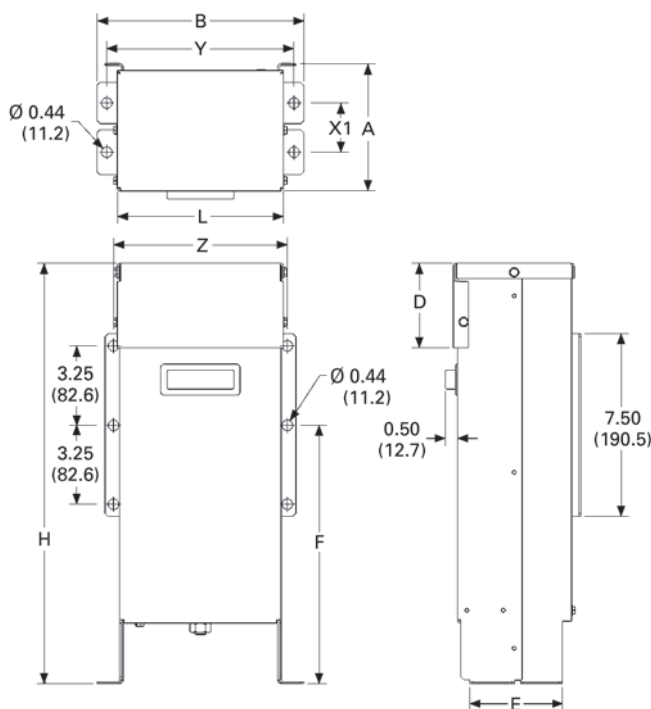

Case B1

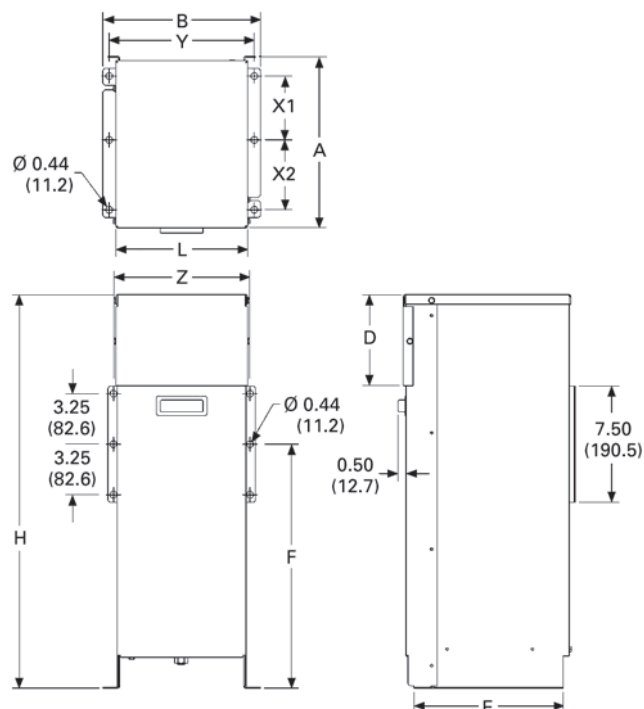

UNIPAK Enclosures

Case Size	A	B	D	E	F	H	L	X1	X2	X3	Y	Z
A1	5.30 (134.6)	8.50 (215.9)	3.50 (88.9)	3.80 (96.5)	10.60 (269.2)	17.30 (439.4)	6.80 (172.7)	2.00 (50.8)	N/A	N/A	7.70 (195.6)	7.20 (182.9)
A2	6.00 (152.4)	8.50 (215.9)	5.60 (142.2)	4.50 (114.3)	13.30 (337.8)	22.30 (566.4)	6.80 (172.7)	2.30 (58.4)	N/A	N/A	7.70 (195.6)	7.20 (182.9)
B1	11.10 (281.9)	10.10 (256.5)	5.80 (147.3)	9.60 (243.8)	15.70 (398.8)	25.30 (642.6)	8.50 (215.9)	4.10 (104.1)	4.50 (114.3)	N/A	9.30 (236.2)	8.80 (223.5)

Legend:

- A = Total depth
- B = Total width
- D = Height of removable front cover
- E = Depth of feet
- F = Height of middle mounting hole in wall bracket
- H = Total height
- L = Width without feet and brackets
- X = Depth between front and rear mounting holes in inches
- Y = Width between floor mounting holes
- Z = Width between wall bracket mounting holes

2.2

SPD, Power Conditioning, PF Capacitors and Harmonic Filters

Power Factor Correction and Harmonic Filtering

Approximate Dimensions in Inches (mm)

Case C1, C2

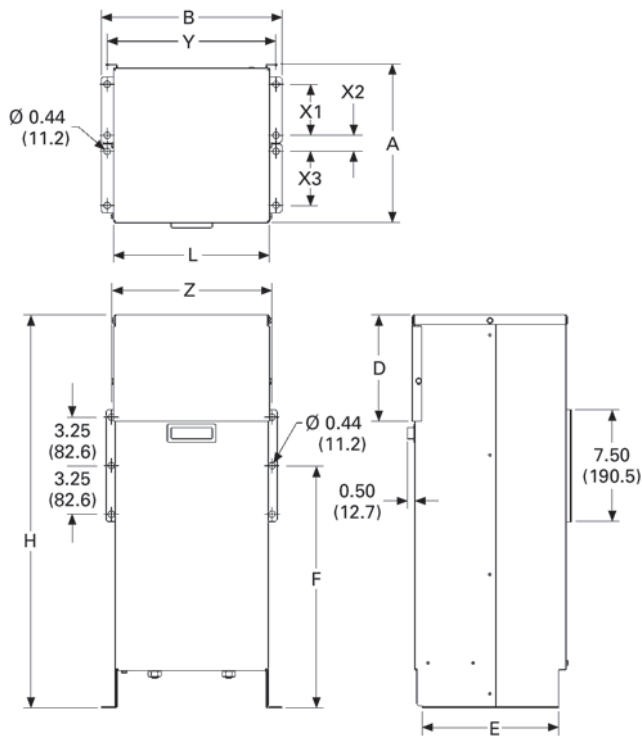

Case D1, E1

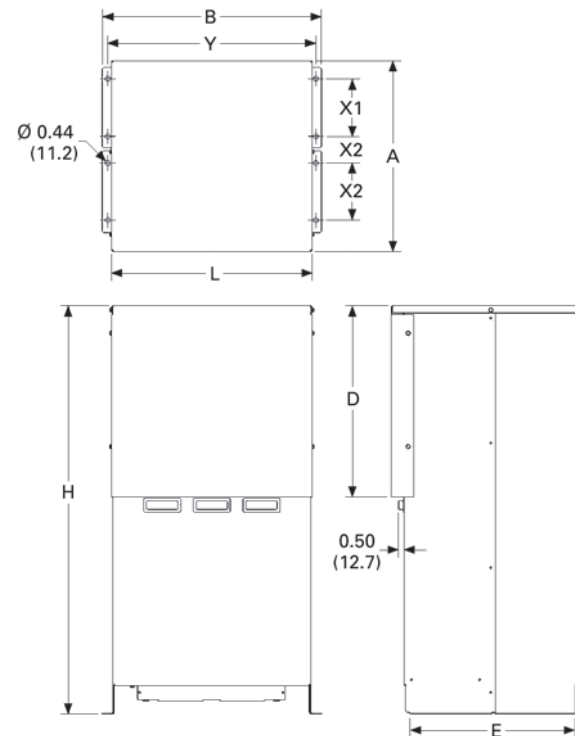

UNIPAK Enclosures

Case Size	A	B	D	E	F	H	L	X1	X2	X3	Y	Z
C1	10.60 (269.2)	12.10 (307.3)	7.10 (180.3)	9.10 (231.1)	16.20 (411.5)	26.30 (668.0)	10.40 (264.2)	3.40 (86.4)	1.10 (27.9)	3.60 (91.4)	11.30 (287.0)	10.70 (271.8)
C2	12.00 (304.8)	19.30 (490.2)	16.90 (429.3)	9.50 (241.3)	16.30 (414.0)	36.00 (914.4)	17.70 (449.6)	3.00 (76.2)	1.50 (38.1)	3.80 (96.5)	18.30 (464.8)	18.00 (457.2)
D1	16.80 (426.7)	19.30 (490.2)	16.90 (429.3)	14.60 (370.8)	N/A	36.00 (914.4)	17.70 (449.6)	5.10 (129.5)	2.40 (61.0)	5.00 (127.0)	18.30 (464.8)	N/A
E1	22.30 (566.4)	24.40 (619.8)	16.80 (426.7)	19.50 (495.3)	N/A	36.00 (914.4)	22.70 (576.6)	6.50 (165.1)	4.40 (111.8)	5.00 (127.0)	22.40 (569.0)	N/A

Legend:

- A = Total depth
- B = Total width
- D = Height of removable front cover
- E = Depth of feet
- F = Height of middle mounting hole in wall bracket
- H = Total height
- L = Width without feet and brackets
- X = Depth between front and rear mounting holes in inches
- Y = Width between floor mounting holes
- Z = Width between wall bracket mounting holes

AUTOVAR 300

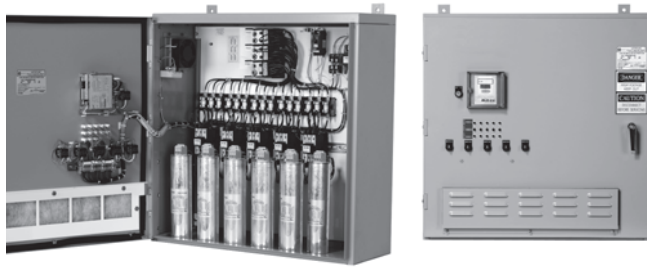

Contents

<i>Description</i>	<i>Page</i>
Product Overview	V3-T2-38
UNIPUMP	V3-T2-41
UNIPAK	V3-T2-44
AUTOVAR 300 Automatic Power Factor Correction Capacitor Systems	
Product Selection	V3-T2-56
Options	V3-T2-56
Dimensions	V3-T2-57
AUTOVAR 600 Automatic Power Factor Correction Capacitor Systems	V3-T2-58
AUTOVAR Filter—LV Automatic Harmonic Filter	V3-T2-63
Transient-Free Static Switching Power Factor Correction Units	V3-T2-67
Active-Harmonic Filter-Harmonic Correction Unit—NEMA 1 Enclosure	V3-T2-71

AUTOVAR 300 Automatic Power Factor Correction Capacitor Systems

Product Description

Automatically switched power factor correction systems for low voltage applications.

- Wallmount design is ideal for minimum space requirements
- Programmable to automatically add/subtract capacitor banks to maintain preset target power factor
- Heavy-duty, three-phase capacitor construction
- Five-year warranty of cells

Application Description

Service entrance power factor correction installations requiring precise maintenance of target power factor in a very small footprint.

Features

Configuration

- **Cabinet:** Wall mounting 12 gauge steel with ANSI 61 gray, NEMA 1 (gasketed)
- **Power line interconnect:** Rugged, power distribution block connection
- **Fusing:** 200,000 ampere interrupting capacity provided on all three phases of each bank. Blade-type fuses mounted on insulator stand-offs with blown-fuse indicating lights
- **Blown-fuse lights:** Blown-fuse indicating lights for each phase and stage located on the door
- **Door interlock:** Door interlock automatically disengages capacitors. Power continues to be provided to the unit until the disconnect is open
- **Exhaust fans:** Provide ventilation. Dust filtering included

Controller

- Digital display of power factor and number of energized banks
- Visual indication of insufficient kVAR to reach target power factor
- LCD backlight display
- Capacitors disabled in steps within 35 ms of main power interruption
- Harmonic measurement up to 19 harmonic and alarm (THDV)
- Automatic detection and correction of CT and phase polarity
- Automatic detection of connected steps
- Maximum 14 output steps
- Provides protection against overvoltage, overtemperature and harmonic overload events
- Advanced control features available
- Optional communications capability (C option controller)
- Standard metering capability
 - Voltage
 - Current (sensed phase only)
 - Frequency
 - Active power (kW)
 - Reactive power (kVAR)
 - Apparent power (kVA)

Contactor

- Fully rated for capacitor switching up to 60 kVAR at 600V
- Integral pre-charge/pre-insertion module standard. The contactor reduces damaging switching transients. This provides safety and durability for the system:
 - Lessens the chance of disrupting sensitive electronic equipment
 - Reduced inrush current extends the life of the capacitor cells

Additional Features

- Optional molded case circuit breaker rated 65 kAIC at 480V and 600V
- Personnel ground fault interruption provides protection in case of accidental contact with control power and ground
- NEMA 3R weatherproofing

Standards and Certifications

- UL/CSA listed and recognized



Product Selection

2

Wallmounted Switched Capacitor Bank



Wallmounted Switched Capacitor Banks—Low Voltage Applications ①

kVAR	Step x kVAR	Rated Current Amperes	Case Size ②	Shipping Weight in Lbs (kg)	Catalog Number
240 Volt					
25	5 x 5	60	J	217 (98.5)	25MCSR2313
50	5 x 10	120	J	255 (115.8)	50MCSR2313
75	5 x 15	180	J	260 (118.0)	75MCSR2313
100	5 x 20	240	J	270 (122.6)	100MCSR231
125	5 x 25	300	J	292 (132.6)	125MCSR231
150	5 x 30	361	J	314 (142.6)	150MCSR231
480 Volt					
50	5 x 10	60	J	200 (90.8)	50MCSR4313
75	5 x 15	90	J	210 (95.3)	75MCSR4313
100	5 x 20	120	J	210 (95.3)	100MCSR4313
125	5 x 25	150	J	240 (109.0)	125MCSR4313
150	5 x 30	180	J	240 (109.0)	150MCSR4313
175	5 x 35	210	J	260 (118.0)	175MCSR431
200	5 x 40	241	J	270 (122.6)	200MCSR431
225	5 x 45	270	J	290 (131.7)	225MCSR431
250	5 x 50	300	J	292 (132.6)	250MCSR431
300	5 x 60	361	J	310 (140.7)	300MCSR431
600 Volt					
50	5 x 10	48	J	200 (90.8)	50MCSR6313
75	5 x 15	72	J	210 (95.3)	75MCSR6313
100	5 x 20	96	J	210 (95.3)	100MCSR6313
125	5 x 25	120	J	240 (109.0)	125MCSR6313
150	5 x 30	144	J	240 (109.0)	150MCSR6313
175	5 x 35	168	J	260 (118.0)	175MCSR631
200	5 x 40	192	J	270 (122.6)	200MCSR631
225	5 x 45	216	J	290 (131.7)	225MCSR631
250	5 x 50	240	J	292 (132.6)	250MCSR631
300	5 x 60	288	J	310 (140.7)	300MCSR631

Options

Description	Option Code
Current transformer—multi-tap, split core current transformer (3000:5A) ③	TX2
Hands-off auto switch—provides manual control to connect or disconnect capacitor stages regardless of controller output	H
Remote alarm relay—relay for a remote alarm to indicate inability to reach target power factor	A
Molded case circuit breaker (65 kAIC at 480V)	M
Weatherproofing (NEMA 3R)	W
Communicating controller	C

Notes

- ① Other ratings available, please consult factory.
- ② For dimensional information, refer to **Page V3-T2-57**.
- ③ A current transformer with a 5 ampere secondary is required to operate an automatic capacitor bank. Rating based on service entrance ampacity. For other ratios, please consult factory.

Dimensions

Approximate Dimensions in Inches (mm)

Enclosure J

Front View

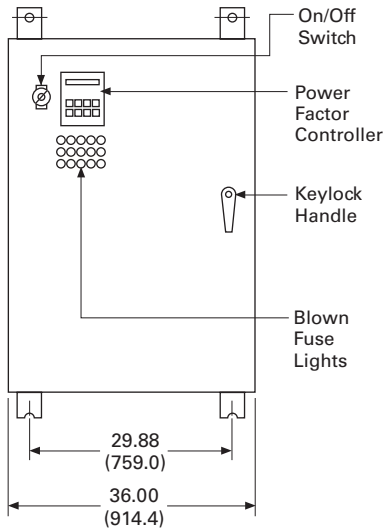

Side View

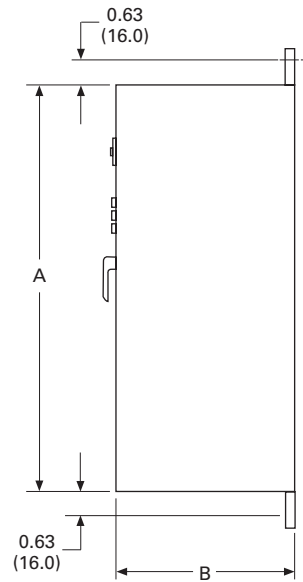

Enclosure J

Description	Height A	Depth B
Without MCCB	36.00 (914.4)	14.00 (355.6)
With MCCB	60.00 (1524.0)	14.00 (355.6)

AUTOVAR 600



2

Contents

<i>Description</i>	<i>Page</i>
Product Overview	V3-T2-38
UNIPUMP	V3-T2-41
UNIPAK	V3-T2-44
AUTOVAR 300 Automatic Power Factor Correction Capacitor Systems	V3-T2-55
AUTOVAR 600 Automatic Power Factor Correction Capacitor Systems	
Standards and Certifications	V3-T2-59
Product Selection	V3-T2-60
Options	V3-T2-61
Dimensions	V3-T2-62
AUTOVAR Filter—LV Automatic Harmonic Filter ..	V3-T2-63
Transient-Free Static Switching Power Factor Correction Units	V3-T2-67
Active-Harmonic Filter-Harmonic Correction Unit—NEMA 1 Enclosure	V3-T2-71

AUTOVAR 600 Automatic Power Factor Correction Capacitor Systems

Product Description

Programmable to automatically add/subtract capacitor banks to maintain preset target power factor.

Application Description

Service entrance power factor correction installations requiring precise maintenance of target power factor.

Features

- Heavy-duty, three-phase capacitor construction
- Five-year warranty of cells

Configuration

- **Cabinet:** 12 gauge steel with ANSI 61 gray, powder coat finish. Lift bolts standard, NEMA 1
- **Power line interconnect:** Rugged, copper bus bar connection with access provided for top or bottom entry. Bus bars are braced for 65 kAIC at 480V. All internal power wiring connections from bus are laid out on a most direct basis with minimum bends for ease of troubleshooting. Clear barrier limiting access to live parts included standard
- **Modular tray design:** Capacitor banks arranged in modular trays with capacitors, fuses, blown-fuse indicating lights, and contactors grouped in a logical, easily understood layout. This permits easy access, quick identification of operating problems and ease of expandability
- **Fusing:** UL recognized, 200,000 ampere interrupting capacity provided on all three phases of each bank. Blade-type fuses mounted on insulator stand-offs
- **Blown-fuse lights:** Blown-fuse indicating lights are on the door located close to individual fuses to facilitate tracing of cleared fuses
- **Push-to-test:** Allows testing of door-mounted blown fuse indicating lights
- **AutoLocate:** When door is open and bus energized, fuse circuit automatically checks for cleared fuses. If a fuse has cleared, the light at the fuse comes on for easy troubleshooting
- **Door interlock:** Door interlock automatically turns off control circuit when engaged. Power continues to be provided to the unit until disconnect is open

- **Exhaust fans:** Two fans per cabinet provide thermal protection. Dust filtering provided
- **Ease of expansion:** Capacitor stage nests are self-contained and can be added in the field. Two bolts mount the nest in the field. Control wire plugs connect to factory standard wire harness on the left side of the cabinet
- **Ease of replacement:** Cells can be easily individually replaced by removing the mounting bolt and lifting out of the nest without removal of any other components

Controller

- Digital display of power factor and number of energized banks
- Visual indication of insufficient kVAR to reach target power factor
- LCD backlight display
- Capacitors disabled in steps within 35 ms of main power interruption
- Harmonic measurement up to 19 harmonic and alarm (THDV)
- Automatic detection and correction of CT and phase polarity
- Automatic detection of connected steps
- Maximum 14 output steps
- Provides protection against overvoltage, overtemperature and harmonic overload events
- Advanced control features available
- Optional communications capability (C option controller)
- Standard metering capability
 - Voltage
 - Current (sensed phase only)
 - Frequency
 - Active power (kW)
 - Reactive power (kVAR)
 - Apparent power (kVA)

Contactors

- Fully rated for capacitor switching up to 60 kVAR at 600V
- Integral pre-charge/pre-insertion module standard. The contactor reduces damaging switching transients. This provides safety and durability for the system:
 - Lessens the chance of disrupting sensitive electronic equipment
 - Reduced inrush current extends the life of the capacitor cells

Additional Features

- Optional molded case circuit breaker, rated 65 kAIC at 48V and 600V
- Personnel ground fault interruption provides protection in case of accidental contact with control power and ground
- Control wiring—standard NEC color-coded modular bundles with quick disconnect feature for ease of troubleshooting or ease of expendability
- Optional digital metering

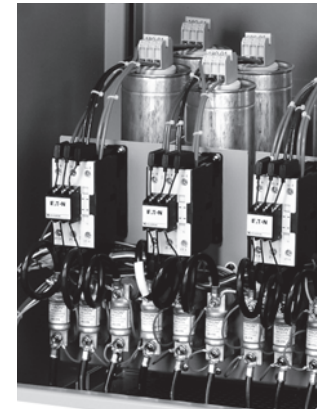
**AUTOVAR 600—Interior View****Bottom Entry Location****Modular Step Nest Assembly****Factory Pre-Wired for Future Expansion****Standards and Certifications**

- UL/CSA listed and recognized



Listed

Product Selection

2 Floor-Mounted Switched Capacitor Banks—Low Voltage Applications

Floor-Mounted
Switched Capacitor
Bank

240 Vac

kVAR	Step x kVAR	Rated Current Amperes	Enclosure Size	Shipping Weight in Lbs (kg)	Catalog Number
75	3 x 25	180	L	644 (292.4)	75TPCSR231
100	4 x 25	214	L	692 (314.2)	100TPCSR231
125	5 x 25	300	L	740 (336.0)	125TPCSR231
150	6 x 25	316	L	788 (357.8)	150TPCSR231
200	8 x 25	481	L	884 (401.3)	200TPCSR231
250	10 x 25	600	L	944 (428.6)	250TPCSR231
300	12 x 25	720	L	1022 (464.0)	300TPCSR231
350	7 x 50	844	KK	1616 (734.0)	350TPCSR231
400	8 x 50	965	KK	1704 (774.0)	400TPCSR231

480 Vac

kVAR	Step x kVAR	Rated Current Amperes	Enclosure Size	Shipping Weight in Lbs (kg)	Catalog Number
150	3 x 50	180	L	632 (287.0)	150TPCSR431
200	4 x 50	240	L	676 (306.9)	200TPCSR431
250	5 x 50	300	L	720 (326.9)	250TPCSR431
300	6 x 50	360	L	764 (346.9)	300TPCSR431
350	7 x 50	420	L	808 (366.8)	350TPCSR431
400	8 x 50	480	L	852 (386.8)	400TPCSR431
450	9 x 50	540	L	896 (406.8)	450TPCSR431
500	10 x 50	600	L	944 (428.6)	500TPCSR431
550	11 x 50	660	L	984 (446.7)	550TPCSR431
600	12 x 50	720	L	1022 (464.0)	600TPCSR431
660	11 x 60	792	L	1010 (458.5)	660TPCSR431
700	7 x 100	840	L	1616 (734.0)	700TPCSR431
720	12 x 60	864	L	1050 (476.7)	720TPCSR431
800	8 x 100	960	KK	1704 (774.0)	800TPCSR431
840	14 x 60	1008	L	1690 (767.7)	840TPCSR431
900	9 x 100	1080	KK	1792 (814.0)	900TPCSR431
1000	10 x 100	1200	KK	1888 (857.0)	1000TPCSR431
1100	11 x 100	1320	KK	1966 (893.0)	1100TPCSR431
1200	12 x 100	1440	KK	2044 (928.0)	1200TPCSR431

Notes

Other ratings and step configurations available, please consult factory.

For dimensional information, refer to **Page V3-T2-62**.

Floor-Mounted
Capacitor Bank

600 Vac

kVAR	Step x kVAR	Rated Current Amperes ^①	Enclosure Size	Shipping Weight in Lbs (kg)	Catalog Number
150	3 x 50	144	L	632 (287.0)	150TPCSR631
200	4 x 50	192	L	676 (306.9)	200TPCSR631
250	5 x 50	240	L	720 (326.9)	250TPCSR631
300	6 x 50	288	L	764 (346.9)	300TPCSR631
350	7 x 50	336	L	808 (366.8)	350TPCSR631
400	8 x 50	384	L	852 (386.8)	400TPCSR631
450	9 x 50	432	L	896 (406.8)	450TPCSR631
500	10 x 50	480	L	944 (428.6)	500TPCSR631
550	11 x 60	528	L	984 (446.7)	550TPCSR631
600	12 x 50	576	L	1022 (464.0)	600TPCSR631
660	11 x 60	634	L	1010 (458.5)	660TPCSR631
700	7 x 100	672	L	1616 (734.0)	700TPCSR631
720	12 x 60	692	L	1050 (476.7)	720TPCSR631
800	8 x 100	768	KK	1704 (774.0)	800TPCSR631
840	14 x 60	1008	L	1690 (767.7)	840TPCSR631
900	9 x 100	864	KK	1792 (814.0)	900TPCSR631
1000	10 x 100	960	KK	1888 (857.0)	1000TPCSR631
1100	11 x 100	1056	KK	1966 (893.0)	1100TPCSR631
1200	12 x 100	1152	KK	2044 (928.0)	1200TPCSR631

Options

Description	Option Code
Current transformer—multi-tap, split core current transformer (3000:5A) ^②	TX2
Hands-off auto switch—provides manual control to connect or disconnect capacitor stages regardless of controller output	H
Remote alarm relay—relay for a remote alarm to indicate inability to reach target power factor	A
Molded case circuit breaker (65 kAIC at 480V)	M
Weatherproofing (NEMA 3R)	W
Communicating controller	C
IQ 250 solid-state meter ^③	Q

Notes

- ^① Other ratings and step sizes available, please consult factory.
^② A current transformer with a 5 ampere secondary is required to operate an automatic capacitor bank. Rating based on service entrance ampacity. For other ratios, please consult factory.
^③ Not available with weatherproofing option.

For dimensional information, refer to **Page V3-T2-62**.

2.2

SPD, Power Conditioning, PF Capacitors and Harmonic Filters

Power Factor Correction and Harmonic Filtering

Dimensions

Approximate Dimensions in Inches (mm)

2

Enclosure L Front View

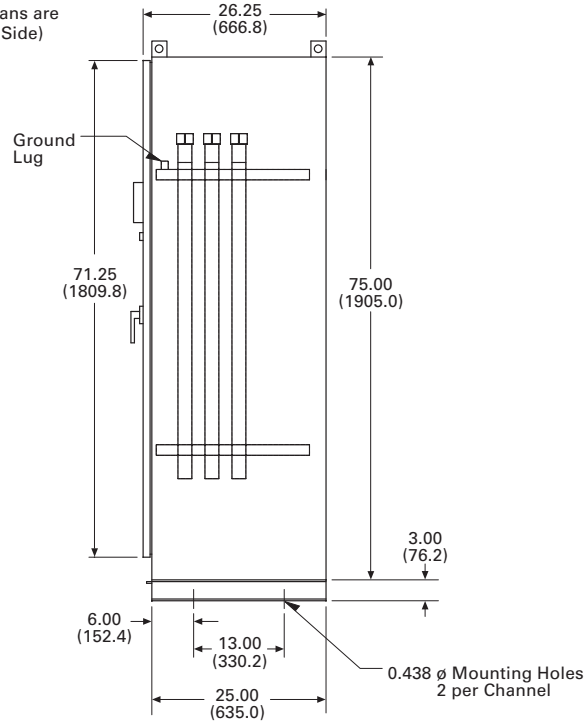
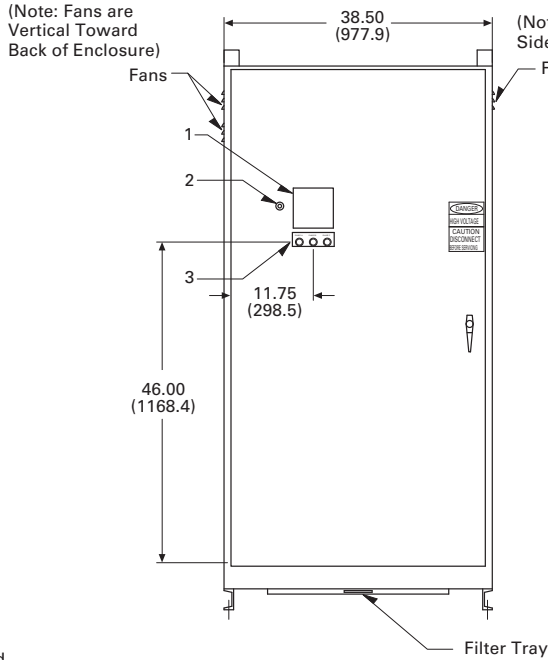

- Legend
1. Controller
 2. On/Off Switch
 3. Blown Fuse Indicator Lights

Enclosure KK Front and Side Views

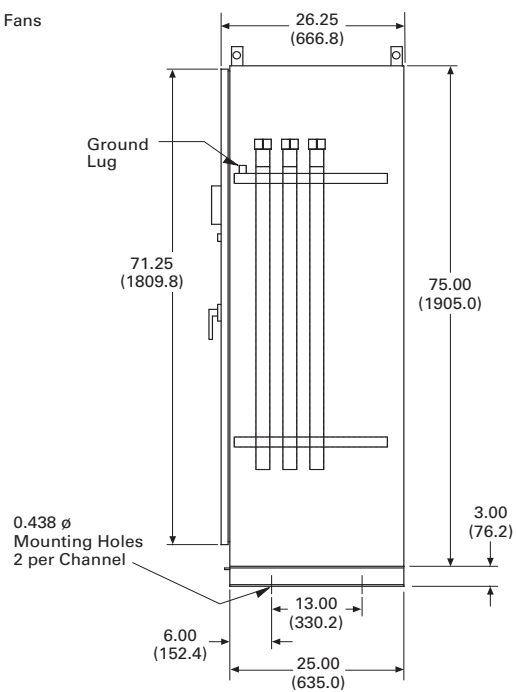
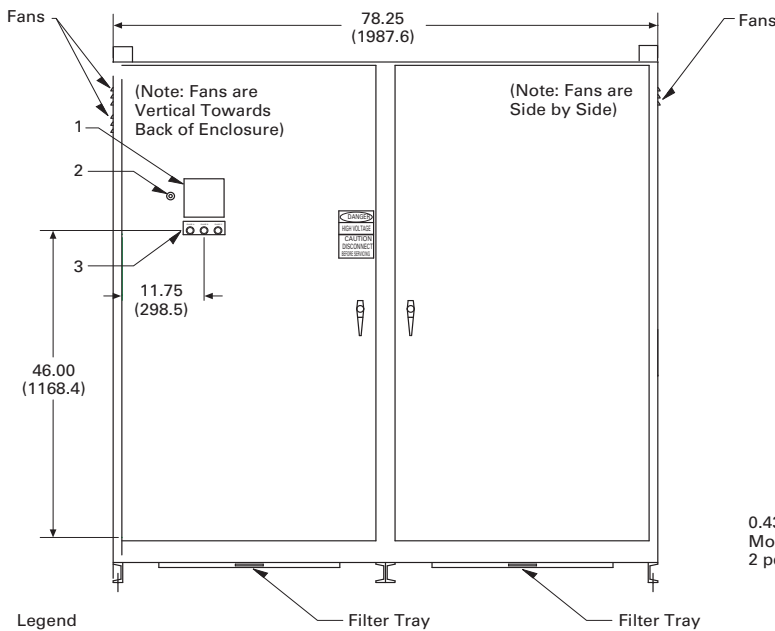

- Legend
1. Controller
 2. On/Off Switch
 3. Blown Fuse Indicating Light

AUTOVAR Filter

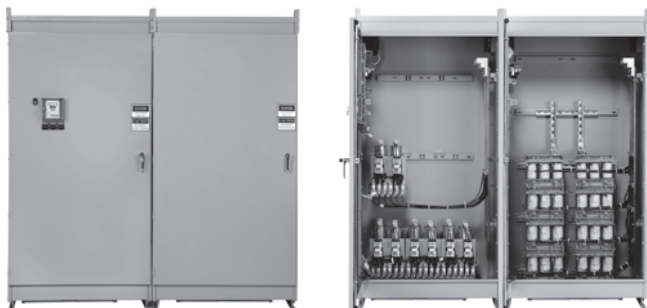

Contents

Description	Page
Product Overview	V3-T2-38
UNIPUMP	V3-T2-41
UNIPAK	V3-T2-44
AUTOVAR 300 Automatic Power Factor Correction Capacitor Systems	V3-T2-55
AUTOVAR 600 Automatic Power Factor Correction Capacitor Systems	V3-T2-58
AUTOVAR Filter—LV Automatic Harmonic Filter Standards and Certifications	V3-T2-64
Product Selection	V3-T2-65
Options	V3-T2-65
Dimensions	V3-T2-66
Transient-Free Static Switching Power Factor Correction Units	V3-T2-67
Active-Harmonic Filter-Harmonic Correction Unit—NEMA 1 Enclosure	V3-T2-71

AUTOVAR Filter—LV Automatic Harmonic Filter

Product Description

Automatically switched harmonic filter/ power factor corrections systems.

- Programmable to automatically add/subtract filter banks to maintain preset target power factor
- Filter steps tuned for maximum efficiency in reducing harmonic currents in three-phase environments with heavy nonlinear loads

Application Description

Service entrance power factor correction installations requiring precise maintenance of target power factor in three-phase, nonlinear, high harmonic environments.

Features

- Efficient modular design for short lead-times, ease of maintenance and ease of future expansion
- Heavy-duty, three-phase capacitor construction with reliable, threaded terminal connections
- Cool operating, 100% copper wound, thermal protected reactors are sized up to 150% of rated capacitor current

Configuration

- **Operation:** AUTOVAR harmonic filters are designed to be sized the same as any power factor correction unit. In most low voltage applications where harmonics are generated by nonlinear loads, no harmonic audit is necessary to design the AUTOVAR filter because it is already designed for typical harmonic spectrums at the kVAR size specified
- **Cabinet:** 12 gauge steel with ANSI 61 gray, powder coat finish. Lift bolts standard, NEMA 1

- **Power line interconnect:** Rugged, copper bus bar connection with access provided for top or bottom entry. Bus bars are braced for 65 kAIC at 480V. All internal power wiring connections from bus are laid out on a most direct basis with minimum bends for ease of troubleshooting. Clear barrier limiting access to live parts included standard
- **Modular tray design:** Capacitor banks arranged in modular trays with capacitors, fuses, blown-fuse indicating lights, and contactors grouped in a logical, easily understood layout. This permits easy access, quick identification of operating problems and ease of expandability
- **Fusing:** UL recognized, 200,000 ampere interrupting capacity provided on all three phases of each bank. Blade-type fuses mounted on insulator stand-offs
- **Blown-fuse lights:** Blown-fuse indicating lights are on the door located close to individual fuses to facilitate tracing of cleared fuses
- **Push-to-test:** Allows testing of door-mounted blown fuse indicating lights.
- **AutoLocate:** When door is open and bus energized, fuse circuit automatically checks for cleared fuses. If a fuse has cleared, the light at the fuse comes on for easy troubleshooting
- **Door interlock:** Door interlock automatically turns off control circuit when engaged. Power continues to be provided to the unit until disconnect is open
- **Exhaust fans:** Two fans per cabinet provide thermal protection. Dust filtering provided
- **Ease of expansion:** Capacitor stage nests are self-contained and can be added in the field. Control wire plugs connect to factory standard wire harness on the left side of the cabinet
- **Ease of replacement:** Cells can be easily individually replaced by removing the mounting bolt and lifting out of the nest without removal of any other components

Controller

- Digital display of power factor and number of energized banks
- Visual indication of insufficient kVAR to reach target power factor
- LCD backlight display
- Capacitors disabled in steps within 35 ms of main power interruption
- Harmonic measurement up to 19 harmonic and alarm (THDV)
- Automatic detection and correction of CT and phase polarity
- Automatic detection of connected steps
- Maximum 14 output steps
- Provides protection against overvoltage, overtemperature and harmonic overload events
- Advanced control features available
- Optional communications capability (C option controller)
- Standard metering capability
 - Voltage
 - Current (sensed phase only)
 - Frequency
 - Active power (kW)
 - Reactive power (kVAR)
 - Apparent power (kVA)

Contactors

- Fully rated for capacitor switching up to 60 kVAR at 600V
- Integral pre-charge/pre-insertion module standard. The contactor reduces damaging switching transients. This provides safety and durability for the system:
 - Lessens the chance of disrupting sensitive electronic equipment
 - Reduced inrush current extends the life of the capacitor cells

Reactors

- **Tuning:** Reactors tuned to the 4.7th harmonic order (nominal 5th). This provides maximum effectiveness in reducing harmonic currents in three-phase systems with harmonics caused by six-pulse devices
- **Detuning:** Reactor designs can be detuned upon request to 4.2nd to protect capacitors against alternate harmonics
- **Windings:** 100% copper windings for minimal temperature rise under load
- **Thermal overload protection:** Each reactor includes three normally closed, auto reset thermostats that open at 180°C. When thermostats engage, the contactor opens
- **Insulation:** 220°C insulation system
- **Warranty:** One-year replacement of reactors

Additional Features

- Optional molded case circuit breaker rated 65 kAIC at 480V and 600V
- Personnel ground fault interruption provides protection in case of accidental contact with control power and ground
- Control wiring—standard NEC color-coded modular bundles with quick disconnect feature for ease of troubleshooting or ease of expendability

**AUTOVAR Filter—Reactor Cabinet****Standards and Certifications**

- UL/CSA listed and recognized



Product Selection

Low Voltage Switched Harmonic Filters

Floor-Mounted
Switched Harmonic
Filter

Floor-Mounted Switched Harmonic Filters—Low Voltage

kVAR	Step x kVAR	Rated Current Amperes ^②	Enclosure Size ^{③④}	Shipping Weight in Lbs (kg)	Catalog Number
480 Vac					
200	4 x 50	240	L	1438 (652.9)	200THFSR431
250 ^①	5 x 50	300	L	1634 (741.8)	250THFSR431
300	6 x 50	360	KK or L + L	1830 (830.8)	300THFSR432
350	7 x 50	420	KK or L + L	2026 (919.8)	350THFSR432
400	8 x 50	480	KK or L + L	2222 (1008.8)	400THFSR432
450	9 x 50	540	KK or L + L	2371 (1076.4)	450THFSR432
500	10 x 50	600	KK or L + L	2525 (1146.4)	500THFSR432
550 ^①	11 x 50	660	KK or L + L	2750 (1248.5)	550THFSR432
600 ^①	12 x 50	720	KK or L + L	2830 (1284.8)	600THFSR432
600 Vac					
300	6 x 50	288	KK or L + L	1830 (830.8)	300THFSR632
350	7 x 50	336	KK or L + L	2026 (919.8)	350THFSR632
400	8 x 50	384	KK or L + L	2222 (1008.8)	400THFSR632
450	9 x 50	432	KK or L + L	2371 (1076.4)	450THFSR632
500	10 x 50	480	KK or L + L	2525 (1146.4)	500THFSR632
550 ^①	11 x 50	528	KK or L + L	2750 (1248.5)	550THFSR632
600 ^①	12 x 50	576	KK or L + L	2830 (1284.8)	600THFSR632

Options

Description	Option Code
Current transformer—multi-tap, split core current transformer ^⑥	TX2
Hands-off auto switch—provides manual control to connect or disconnect capacitor stages regardless of controller output	H
Remote alarm relay—relay for a remote alarm to indicate inability to reach target power factor	A
Molded case circuit breaker (65 kAIC at 480V)	M
Weatherproofing (NEMA 3R)	W
Communicating controller	C
IQ 250 solid-state meter ^⑥	Q

Notes

- ^① Enclosures for 550 and 600 kVAR at 480 and 600V will be one double-door section wide if circuit breakers are required (enclosure size KK). Enclosure for 250 kVAR at 480V will be one double-door section wide if a circuit breaker is required.
- ^② Other ratings available, please consult factory.
- ^③ L + L under enclosure size denotes two size L enclosures—one for the capacitors, one for the reactor case.
- ^④ For KK enclosure design, change the last digit of the catalog number to 1. For example, 500THFSR431.
- ^⑤ A current transformer with a 5 ampere secondary is required to operate an automatic capacitor bank. Rating based on service entrance ampacity. For other ratios, please consult factory.
- ^⑥ Not available with weatherproofing option.

For dimensional information, refer to **Page V3-T2-66**.

Dimensions

Approximate Dimensions in Inches (mm)

2

Enclosures L + L Front and Side Views

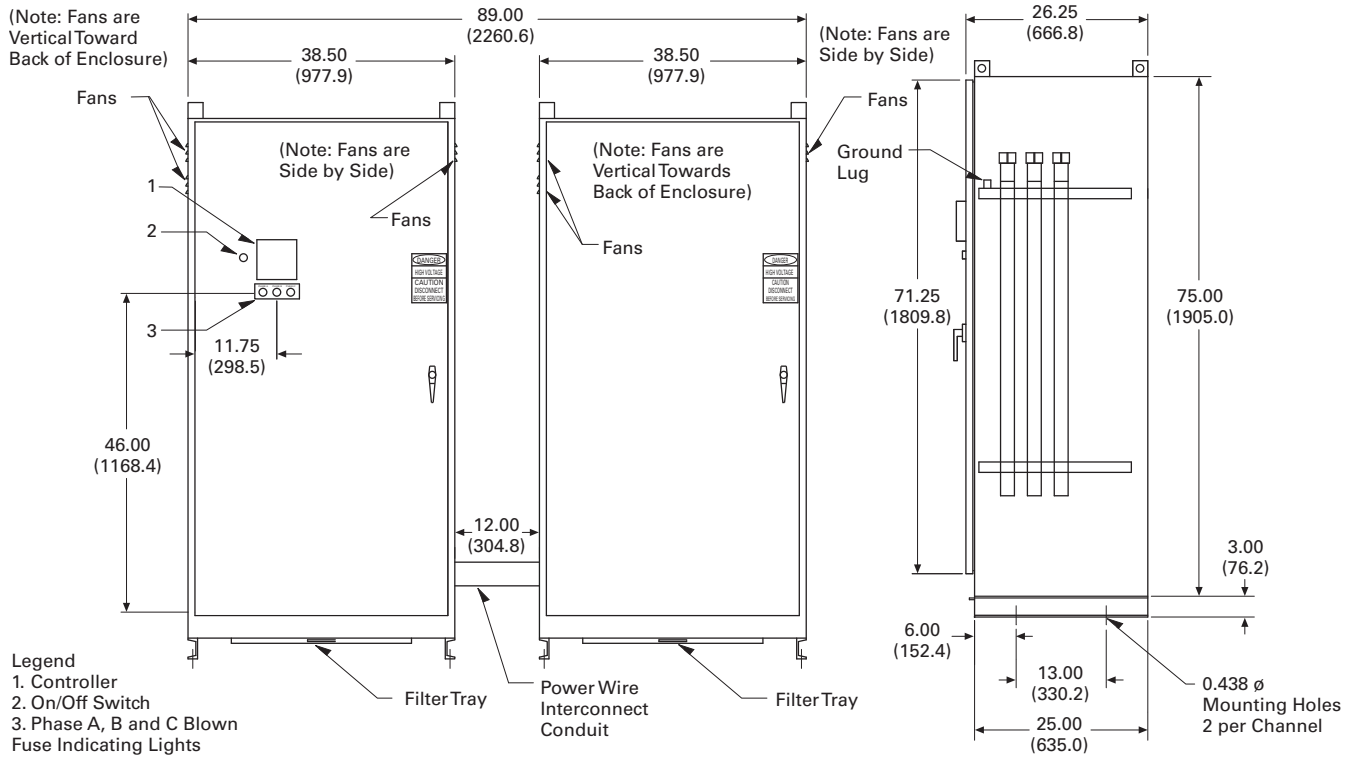

Transient-Free Power Factor Correction System**Contents**

Description	Page
Product Overview	V3-T2-38
UNIPUMP	V3-T2-41
UNIPAK	V3-T2-44
AUTOVAR 300 Automatic Power Factor Correction Capacitor Systems	V3-T2-55
AUTOVAR 600 Automatic Power Factor Correction Capacitor Systems	V3-T2-58
AUTOVAR Filter—LV Automatic Harmonic Filter	V3-T2-63
Transient-Free Static Switching Power Factor Correction Units	
Features, Benefits and Functions	V3-T2-68
Standards and Certifications	V3-T2-68
Catalog Number Selection	V3-T2-69
Technical Data and Specifications	V3-T2-69
Dimensions	V3-T2-70
Active-Harmonic Filter-Harmonic Correction Unit—NEMA 1 Enclosure	V3-T2-71

Transient-Free Static Switching Power Factor Correction Units**Product Description**

Transient-free statically switch capacitor units are available in two models.

The FTE model is a real-time transient-free system, used to compensate extremely rapid loads within one cycle of operation (typically 5–20 msec).

The FTA model is a fast transient-free system, used to compensate any loads within 3–4 seconds.

The FTA and FTE units employ a fast or real-time response, and include the ability to switch larger steps without creating significant line noise. These relatively maintenance-free units reside in a smaller footprint and are ideal for use in applications such as flicker control, large motor starting, bus voltage stabilization, fault ride-through solutions, power factor correction and many more.

Application Description

- Motor starting
- On-site generation support
- Spot welding
- Wind turbines
- Other dynamic loads

Three current transformers with a 5 ampere secondary are required to operate this capacitor bank.

Rating based on Service Entrance Ampacity. For other ratios, please consult factory.

- Startup and Commissioning by factory trained personnel is required for proper operation and warranty of this system

Application Example—Spot Welding

Spot Welding (Auto Manufacturer)

2

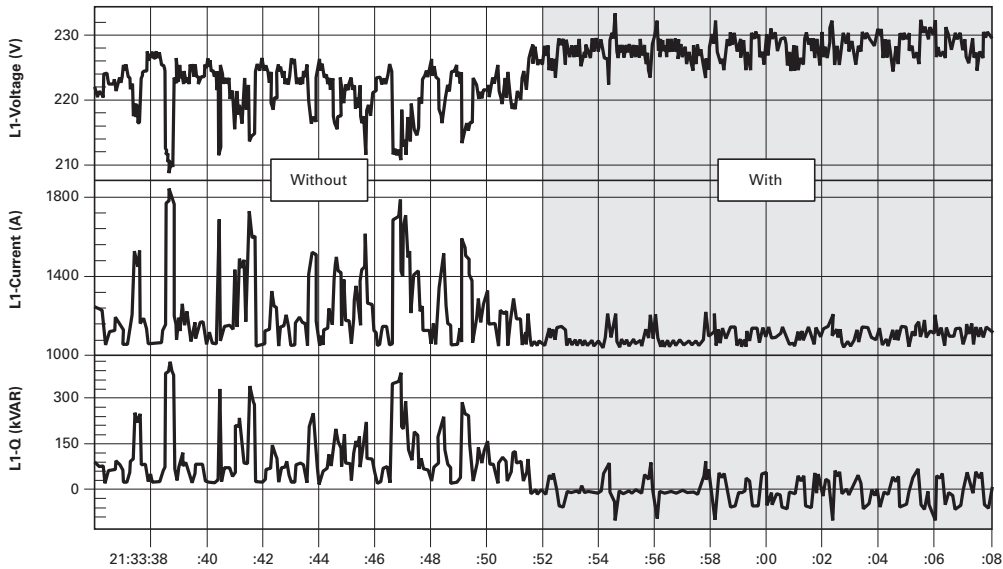

Features, Benefits and Functions

- Transient-free capacitor group switching, using electronic switching elements
 - Simultaneous connection/disconnection of all required steps
 - Consistent capacitor values and stable filter characteristics
 - Harmonic filtration
 - Three independent control modes:
 - Power factor control
 - Voltage control
 - Load sharing with another compensation system connected to the same transformer
 - Unique SCAN feature reduces capacitor duty cycles
 - Remote control of compensation systems available via LAN or Ethernet
 - Integrated three-phase network analyzer:
 - Measures all power parameters on each phase (V, I, kW, kVAR, kVA)
 - Measures voltage and current harmonics to the 63rd harmonic
- FTE unit includes all of the above, plus:
- Reduces voltage flicker and voltage sag
 - Provides network reactive power support
 - Offers voltage control options

Standards and Certifications

Enclosure

- EMC—EN50081-2, EN50082-2, EN55011, EN61000-4-2/3/4/5, ENV50204, ENV50141
- CE Mark—73/23/EEC am. 93/68, 98/37/EC art. 4(2)
- Safety—EN61010-1, EN60439-1, EN60204
- UL 508
- CSA



Catalog Number Selection

TFSS

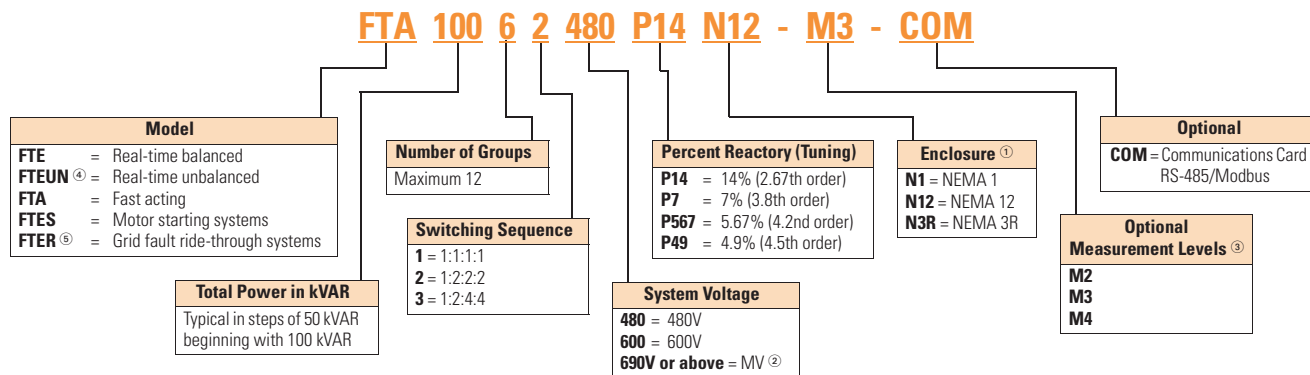

Technical Data and Specifications

Product Configurations

Network voltage

- 210–690V
- Engineered solutions up to 15 kV

Frequency

- 45–55 Hz for 50 Hz network
- 55–65 Hz for 60 Hz network

Capacitor group configurations

- Up to 12 groups per one controller
- Switching sequence:
 - 1:1:1:1 (all equal)
 - 1:2:2:2 (half group)
 - 1:2:4:4 (quarter, half groups)

Acquisition time

- FTE—5–20 ms for a 50 Hz network
- FTE—4–16 ms for a 60 Hz network
- FTA—1–4 second maximum

Notes

- ① All models are CE approved. Please notify if UL or cUL is required.
- ② MV units require:
 - A correctly sized and specified step-up transformer
 - MV and LV interconnection, switching and protection
- ③ All systems are offered with Measurement Level 1 (f, I, V, kW, kVAR, kVA, PF) and no communications card. The measurement levels can be upgraded to Measurement Level 2 (adds THD I and THDV), Measurement Level 3 (adds waveforms, I and V harmonics) and Measurement Level 4 (adds event log).
- ④ Balanced system employs two-phase switching, unbalanced system employs individual three-phase switching.
- ⑤ For motor start and grid fault ride-through solutions, please consult factory.

Dimensions

Approximate Dimensions in Inches (mm)

2

**Transient-Free Reactive Power Compensation Systems—
Real-Time Transient-Free Systems—480 Vac****Compensate Rapid Loads Within One Cycle
(Typically 5–20 ms)—Standard 6% Inductors—
Detuned to 245 Hz (4.08th Harmonic)**

Catalog Number	Width	Depth	Height
FTE15652480	31.50 (800.1)	23.60 (599.4)	82.70 (2100.6)
FTE18752480	31.50 (800.1)	23.60 (599.4)	82.70 (2100.6)
FTE21974480	31.50 (800.1)	23.60 (599.4)	82.70 (2100.6)
FTE25052480	31.50 (800.1)	23.60 (599.4)	82.70 (2100.6)
FTE26274480	31.50 (800.1)	23.60 (599.4)	82.70 (2100.6)
FTE31252480	31.50 (800.1)	23.60 (599.4)	82.70 (2100.6)
FTE37552480	31.50 (800.1)	23.60 (599.4)	82.70 (2100.6)
FTE43774480	31.50 (800.1)	23.60 (599.4)	82.70 (2100.6)
FTE45031480	31.50 (800.1)	23.60 (599.4)	82.70 (2100.6)
FTE60661480	63.00 (1600.2)	23.60 (599.4)	82.70 (2100.6)
FTE687112480	63.00 (1600.2)	23.60 (599.4)	82.70 (2100.6)
FTE75061480	63.00 (1600.2)	23.60 (599.4)	82.70 (2100.6)
FTE825112480	63.00 (1600.2)	23.60 (599.4)	82.70 (2100.6)
FTE90061480	63.00 (1600.2)	23.60 (599.4)	82.70 (2100.6)
FTE112591480	94.50 (2400.3)	23.60 (599.4)	82.70 (2100.6)
FTE135091480	94.50 (2400.3)	23.60 (599.4)	82.70 (2100.6)
FTE1500121480	126.00 (3200.4)	23.60 (599.4)	82.70 (2100.6)
FTE1800121480	126.00 (3200.4)	23.60 (599.4)	82.70 (2100.6)

**Compensate Rapid Loads Within One Cycle
(Typically 5–20 ms)—4.5% Inductors—
Tuned to 282 Hz (4.7th Harmonic)**

Catalog Number	Width	Depth	Height
FTE15652480T	31.50 (800.1)	23.60 (599.4)	82.70 (2100.6)
FTE18752480T	31.50 (800.1)	23.60 (599.4)	82.70 (2100.6)
FTE21974480T	31.50 (800.1)	23.60 (599.4)	82.70 (2100.6)
FTE25052480T	31.50 (800.1)	23.60 (599.4)	82.70 (2100.6)
FTE26274480T	31.50 (800.1)	23.60 (599.4)	82.70 (2100.6)
FTE31252480T	31.50 (800.1)	23.60 (599.4)	82.70 (2100.6)
FTE37552480T	31.50 (800.1)	23.60 (599.4)	82.07 (2100.6)
FTE43774480T	31.50 (800.1)	23.60 (599.4)	82.70 (2100.6)
FTE45031480T	31.50 (800.1)	23.60 (599.4)	82.70 (2100.6)
FTE60661480T	63.00 (1600.2)	23.60 (599.4)	82.70 (2100.6)
FTE687112480T	63.00 (1600.2)	23.60 (599.4)	82.70 (2100.6)
FTE75061480T	63.00 (1600.2)	23.60 (599.4)	82.70 (2100.6)
FTE825112480T	63.00 (1600.2)	23.60 (599.4)	82.70 (2100.6)
FTE90061480T	63.00 (1600.2)	23.60 (599.4)	82.70 (2100.6)
FTE112591480T	94.50 (2400.3)	23.60 (599.4)	82.70 (2100.6)
FTE135091480T	94.50 (2400.3)	23.60 (599.4)	82.70 (2100.6)
FTE1500121480T	126.00 (3200.4)	23.60 (599.4)	82.70 (2100.6)
FTE1800121480T	126.00 (3200.4)	23.60 (599.4)	82.70 (2100.6)

**Transient-Free Reactive Power Compensation Systems—
Fast Transient-Free Switching Systems—480 Vac****Compensate Any Load Within 3–4 Seconds—Standard 6%
Inductors—Detuned to 245 Hz (4.08th Harmonic)**

Catalog Number	Width	Depth	Height
FTA15652480	31.50 (800.1)	23.60 (599.4)	82.70 (2100.6)
FTA18752480	31.50 (800.1)	23.60 (599.4)	82.70 (2100.6)
FTA21974480	31.50 (800.1)	23.60 (599.4)	82.70 (2100.6)
FTA25052480	31.50 (800.1)	23.60 (599.4)	82.70 (2100.6)
FTA26274480	31.50 (800.1)	23.60 (599.4)	82.70 (2100.6)
FTA31252480	31.50 (800.1)	23.60 (599.4)	82.70 (2100.6)
FTA37552480	31.50 (800.1)	23.60 (599.4)	82.70 (2100.6)
FTA43774480	31.50 (800.1)	23.60 (599.4)	82.70 (2100.6)
FTA45031480	31.50 (800.1)	23.60 (599.4)	82.70 (2100.6)
FTA60661480	63.00 (1600.2)	23.60 (599.4)	82.70 (2100.6)
FTA687112480	63.00 (1600.2)	23.60 (599.4)	82.70 (2100.6)
FTA75061480	63.00 (1600.2)	23.60 (599.4)	82.70 (2100.6)
FTA825112480	63.00 (1600.2)	23.60 (599.4)	82.70 (2100.6)
FTA90061480	63.00 (1600.2)	23.60 (599.4)	82.70 (2100.6)
FTA112591480	94.50 (2400.3)	23.60 (599.4)	82.70 (2100.6)
FTA135091480	94.50 (2400.3)	23.60 (599.4)	82.70 (2100.6)
FTA1500121480	126.00 (3200.4)	23.60 (599.4)	82.70 (2100.6)
FTA1800121480	126.00 (3200.4)	23.60 (599.4)	82.70 (2100.6)

**Compensate Any Load Within 3–4 Seconds—4.5%
Inductors—Tuned to 282 Hz (4.7th Harmonic)**

Catalog Number	Width	Depth	Height
FTA15652480T	31.50 (800.1)	23.60 (599.4)	82.70 (2100.6)
FTA18752480T	31.50 (800.1)	23.60 (599.4)	82.70 (2100.6)
FTA21974480T	31.50 (800.1)	23.60 (599.4)	82.70 (2100.6)
FTA25052480T	31.50 (800.1)	23.60 (599.4)	82.70 (2100.6)
FTA26274480T	31.50 (800.1)	23.60 (599.4)	82.70 (2100.6)
FTA31252480T	31.50 (800.1)	23.60 (599.4)	82.70 (2100.6)
FTA37552480T	31.50 (800.1)	23.60 (599.4)	82.70 (2100.6)
FTA43774480T	31.50 (800.1)	23.60 (599.4)	82.70 (2100.6)
FTA45031480T	31.50 (800.1)	23.60 (599.4)	82.70 (2100.6)
FTA60661480T	63.00 (1600.2)	23.60 (599.4)	82.07 (2100.6)
FTA687112480T	63.00 (1600.2)	23.60 (599.4)	82.70 (2100.6)
FTA75061480T	63.00 (1600.2)	23.60 (599.4)	82.70 (2100.6)
FTA825112480T	63.00 (1600.2)	23.60 (599.4)	82.70 (2100.6)
FTA90061480T	63.00 (1600.2)	23.60 (599.4)	82.70 (2100.6)
FTA112591480T	94.50 (2400.3)	23.60 (599.4)	82.70 (2100.6)
FTA135091480T	94.50 (2400.3)	23.60 (599.4)	82.70 (2100.6)
FTA1500121480T	126.00 (3200.4)	23.60 (599.4)	82.70 (2100.6)
FTA1800121480T	126.00 (3200.4)	23.60 (599.4)	82.70 (2100.6)

Harmonic Correction Units—NEMA 1 Enclosure



Contents

<i>Description</i>	<i>Page</i>
Product Overview	V3-T2-38
UNIPUMP	V3-T2-41
UNIPAK	V3-T2-44
AUTOVAR 300 Automatic Power Factor Correction Capacitor Systems	V3-T2-55
AUTOVAR 600 Automatic Power Factor Correction Capacitor Systems	V3-T2-58
AUTOVAR Filter—LV Automatic Harmonic Filter	V3-T2-63
Transient-Free Static Switching Power Factor Correction Units	V3-T2-67
Active-Harmonic Filter-Harmonic Correction Unit—NEMA 1 Enclosure	
Technical Data and Specifications	V3-T2-72
Wiring Diagrams	V3-T2-72
Dimensions	V3-T2-74

Active-Harmonic Filter-Harmonic Correction Unit—NEMA 1 Enclosure

Product Description

Active Harmonic Filters (Harmonic Correction Units—HCUEs) provide dynamic harmonic correction by actively injecting equal and opposite currents into the customer’s electrical distribution system that cancel the entire spectrum of harmonic currents at the point of connection.

Application Description

Typical applications include locations with large amounts of nonlinear loads including 6- and 12-pulse PWM AC variable frequency drives, DC drives, as well as other switch-mode power supply equipment. This equipment can be found in water and wastewater treatment facilities, industrial manufacturing and warehousing plants, military bases, and commercial (HVAC) locations.

Features, Benefits and Functions

Unlike passive filters, by providing dynamic correction, HCUEs can provide effective harmonic correction for varying load conditions and harmonic spectrums up to their rated capacity. HCUEs also have the secondary benefit of providing power factor correction with any excess capacity after correcting all harmonic conditions.

- Fast action
- NEMA 1 and NEMA 12 enclosures available:
 - Wallmount (50 and 100 ampere designs)
 - Floor-standing (300 ampere design)
- Touchscreen HMI
- Modbus and Ethernet connectivity

Note: Requires at least 3% series input line reactor or equivalent 6% DC bus choke in each AC drive for optimum performance.

Standards and Certifications

- UL/CSA approved



Advantages

- Can be sized to guarantee specific levels of harmonic correction, such as meeting IEEE 519 recommended levels
- Cannot be overloaded
- Can be expanded without affecting performance
- Broad spectrum of cancellation (2nd to 50th harmonic)
- Power factor improvement
- Easier and less expensive installation
- Comprehensive control

Technical Data and Specifications

- 20 kHz switching carrier frequency
- 208–480V $\pm 10\%$, 600V and 690V with autotransformer
- 50/60 Hz ± 3 Hz frequency
- Ambient temperature 0°C to +40°C enclosed
- Seismic Zone 4
- Output capacity—self limited to 100% current rated
- Corrective capability— $<5\%$ TDD and near unity displacement power factor

Harmonic Control Unit Ratings—NEMA 1 Enclosed

Model	Voltage	Frequency	Total Current Amperes (rms)	Watt Losses (kw)	Enclosure Type	Disconnect
HCUE050D5N1	208–480	50/60 Hz	50	1.8	Wallmount/NEMA 1	—
HCUE100D5N1	208–480	50/60 Hz	100	3.0	Wallmount/NEMA 1	—
HCUE300D5N1	208–480	50/60 Hz	300	8.0	Free-standing/NEMA 1	X
HCUE050D6N1	600	50/60 Hz	39	1.8	Free-standing/NEMA 1	—
HCUE050D7N1	690	50/60 Hz	33	1.8	Free-standing/NEMA 1	—
HCUE100D6N1	600	50/60 Hz	78	3.0	Free-standing/NEMA 1	—
HCUE100D7N1	690	50/60 Hz	65	3.0	Free-standing/NEMA 1	—
HCUE300D6N1	600	50/60 Hz	235	8.0	Free-standing/NEMA 1	—
HCUE300D7N1	690	50/60 Hz	200	8.0	Free-standing/NEMA 1	—

Current Transformer Ratings ^①

Model	AC Line Current Rating	Type
HCUCT1000SC	1000	Split
HCUCT3000SC	3000	Split
HCUCT5000SC	5000	Split

Wiring Diagrams

Installation Diagram

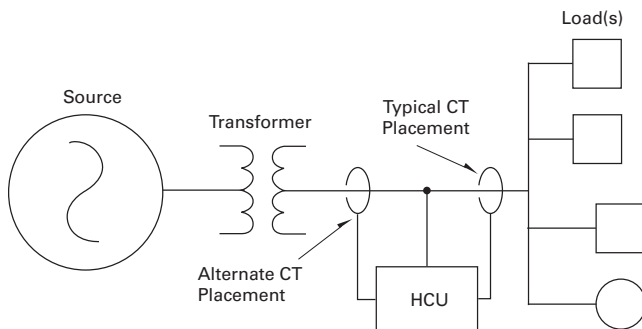

Note

- ^① Current transformers are rated for 400 Hz. Two current transformers are required for three-phase loads. Three current transformers are required when single-phase loads are present. Rating based on service entrance ampacity and optional parallel operation. For other ratios, please consult factory. Startup and commissioning by factory trained personnel is required for proper operation and warranty of this system.

Source CT Location

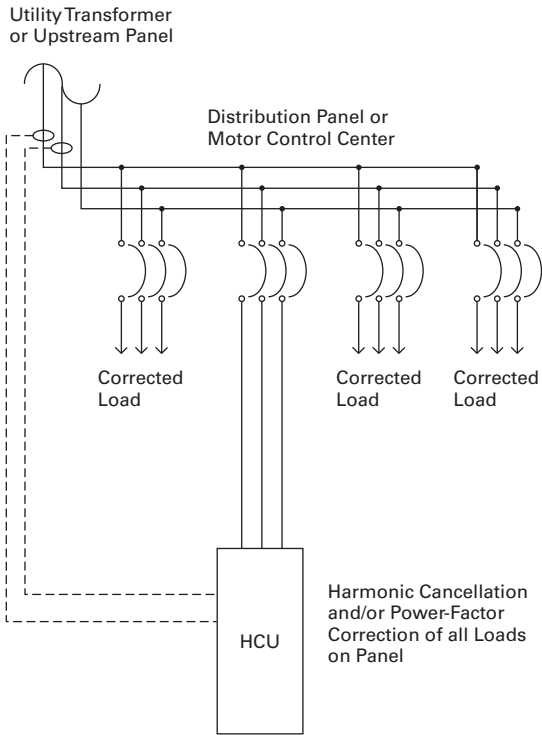

Source or Load CT Location

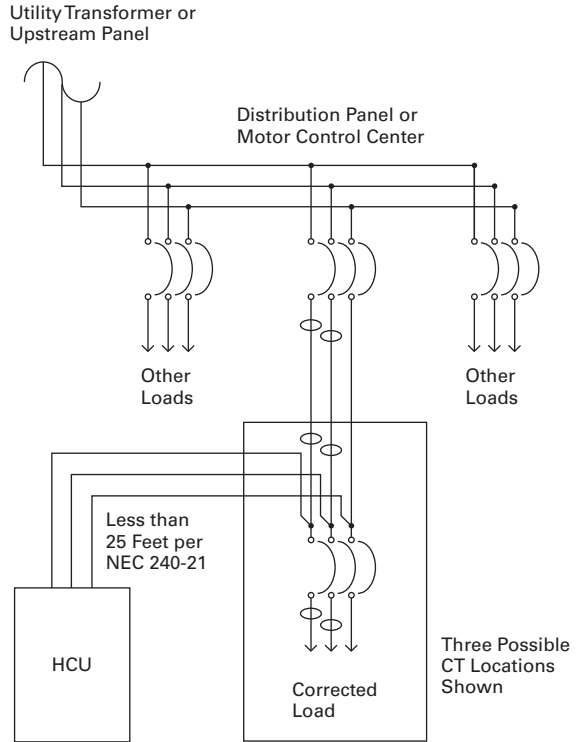

Source or Load CT Location

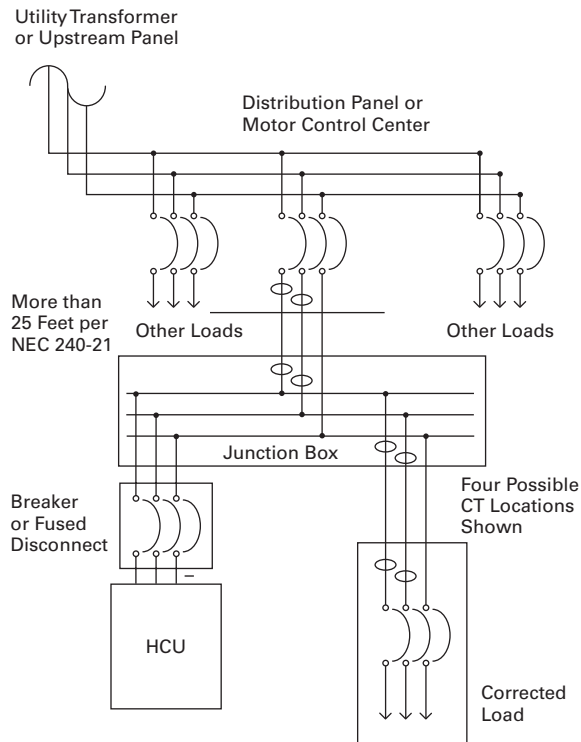

Load CT Location

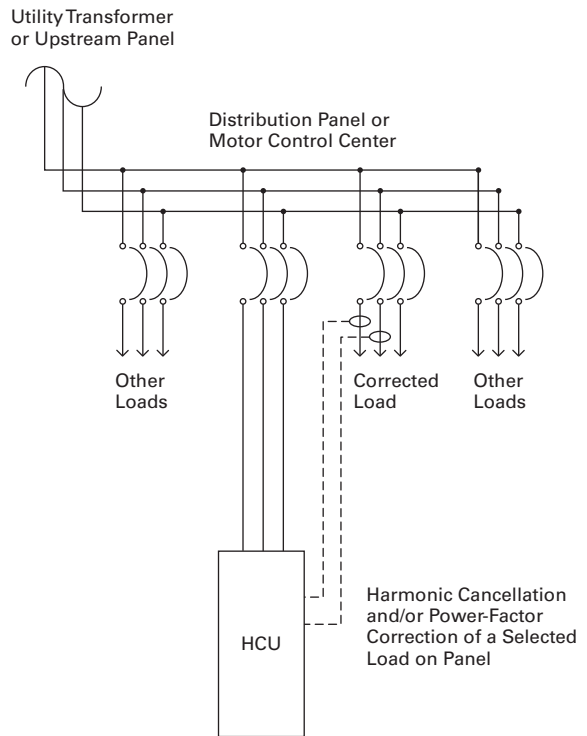

Dimensions

Approximate Dimensions in Inches (mm)

2

Harmonic Control—NEMA 1 Enclosed

Model	Exterior			Unit Weight in Lbs (kg)
	Height	Weight	Depth	
HCUE050D5N1	51.80 (1315.7)	20.70 (525.8)	18.50 (469.9)	250 (113.5)
HCUE100D5N1	68.70 (1745.0)	20.70 (525.8)	18.50 (469.9)	350 (158.9)
HCUE300D5N1	74.90 (1902.5)	32.20 (817.9)	19.50 (495.3)	775 (351.9)
HCUE050D6N1	①	①	①	①
HCUE050D7N1	①	①	①	①
HCUE100D6N1	①	①	①	①
HCUE100D7N1	①	①	①	①
HCUE300D6N1	①	①	①	①
HCUE300D7N1	①	①	①	①

Current Transformer

Model	Internal Diameter
HCUCT1000SC	4.65 (118.1)
HCUCT3000SC	6.50 (165.1)
HCUCT5000SC	7.50 (190.5)

Auxiliary Current Transformers ②

Model	Ratio	Type
HCUCT7RL6011	600/1	Solid round core
HCUCT7RL1021	1000/1	Solid round core

Notes

- ① Consult factory.
 ② Required for parallel operation of HCU and for units with transformers. Use the same number of auxiliary CTs as main sensing CTs.

Approximate Dimensions in Inches (mm)

Drawings—NEMA 1 Enclosure

HCUE050 Layout Dimensions

The HCUE050 series offers 50 amperes of corrective current in a convenient package. The enclosed model comes standard with a digital interface panel for control diagnostics and programming. Input fuses are included. The enclosed unit includes a removable panel for bottom conduit entry.

HCUE050—50 Amperes, 208–480V

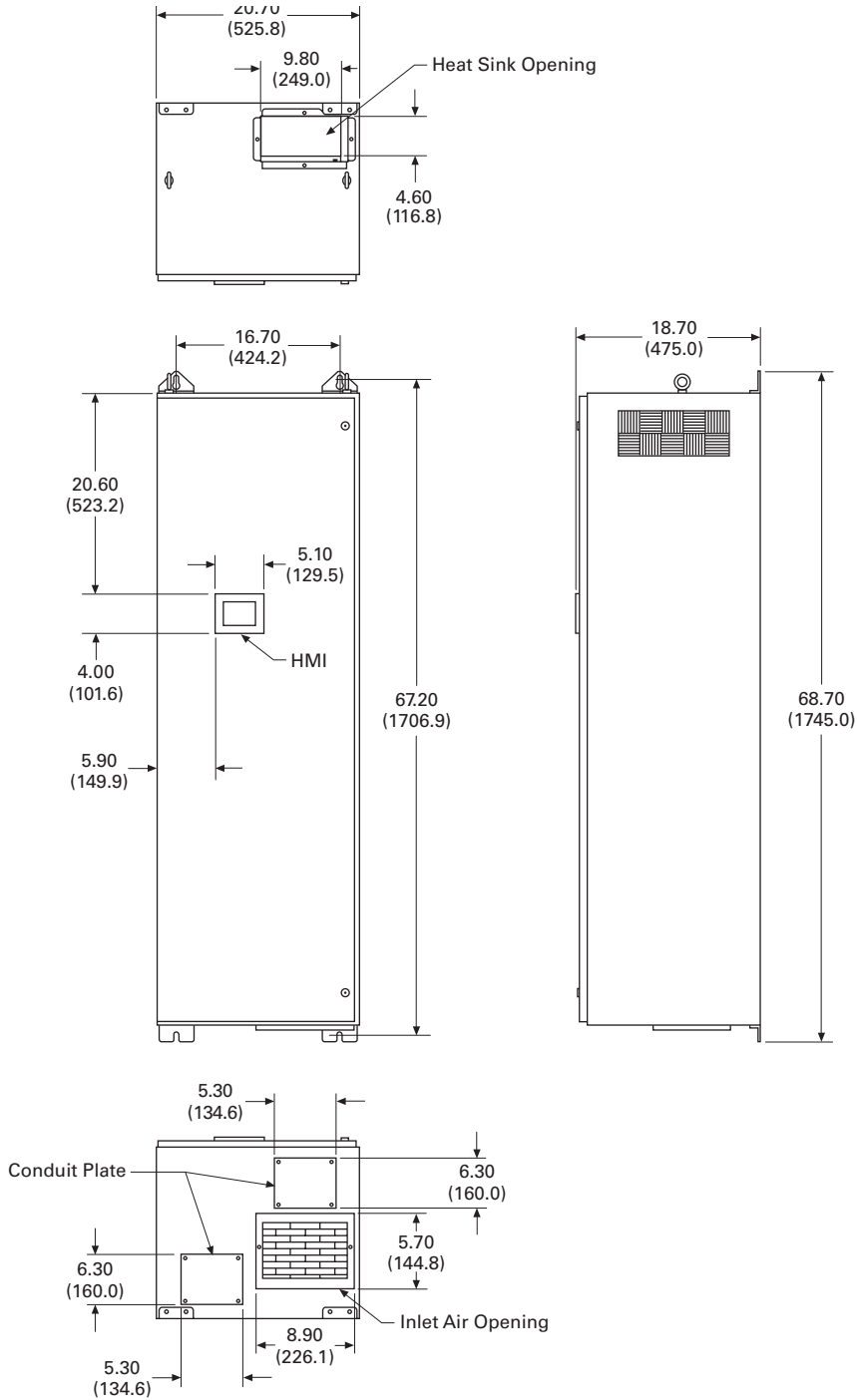

2.2

SPD, Power Conditioning, PF Capacitors and Harmonic Filters

Power Factor Correction and Harmonic Filtering

Approximate Dimensions in Inches (mm)

2

HCUE100 Layout Dimensions

The HCUE100 series offers 100 amperes of corrective current in a wallmounted NEMA 1 enclosure. The enclosed model comes standard with a digital interface module for control, diagnostics and programming. Input fuses are included. The enclosed unit includes a removable panel for bottom conduit entry.

HCUE100—100 Amperes 208–480V

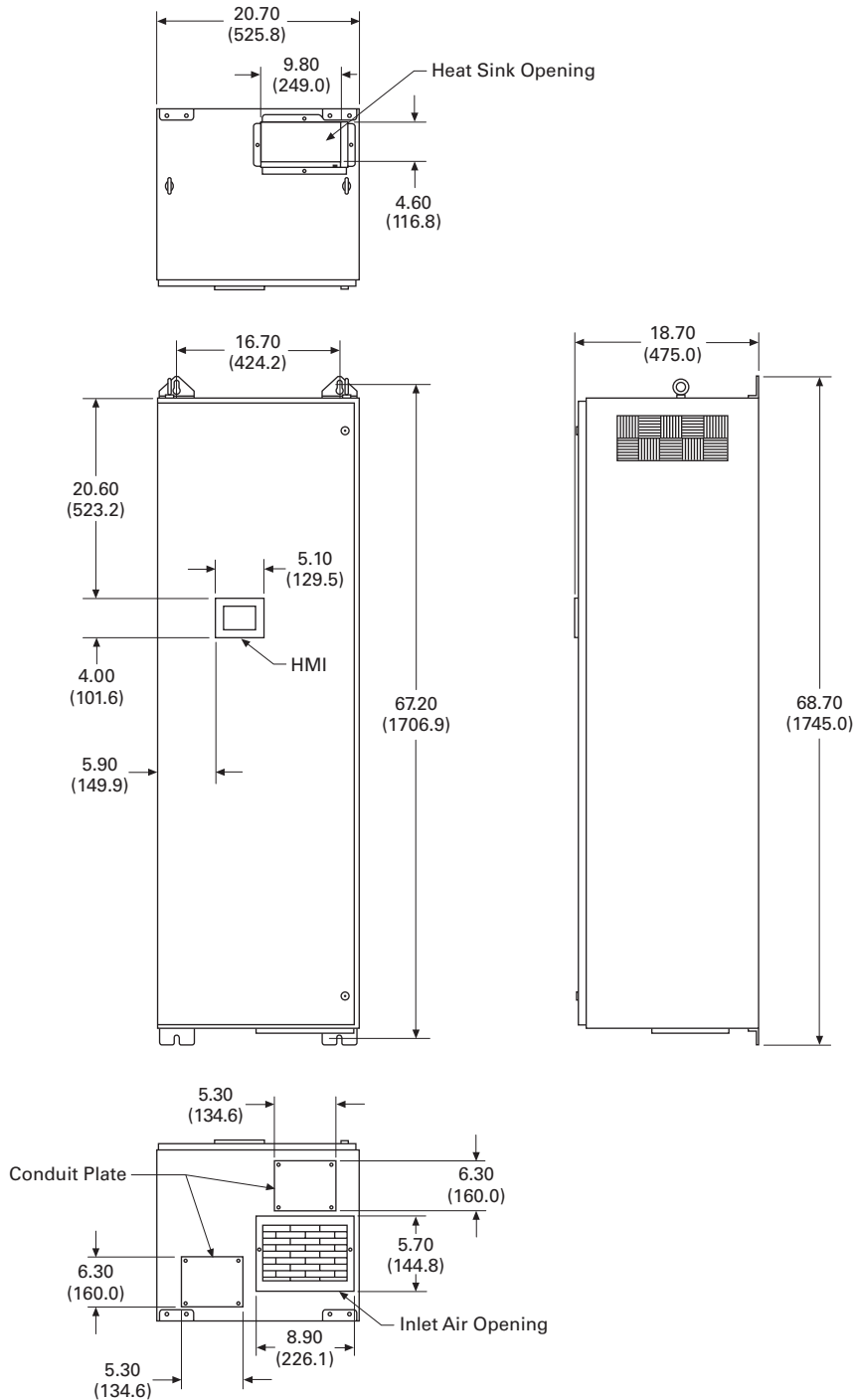

Approximate Dimensions in Inches (mm)

HCUE300 Layout Dimensions

The HCUE300 series offers 300 amperes of corrective current for large capacity applications. It is available in a floor-standing NEMA 1 enclosure (including a door-interlocking disconnect). The enclosed model comes standard with digital interface module for control, diagnostics and programming. Input fuses are included. The enclosed unit includes a removable panel for top conduit entry.

HCUE300—300 Amperes 208–480V

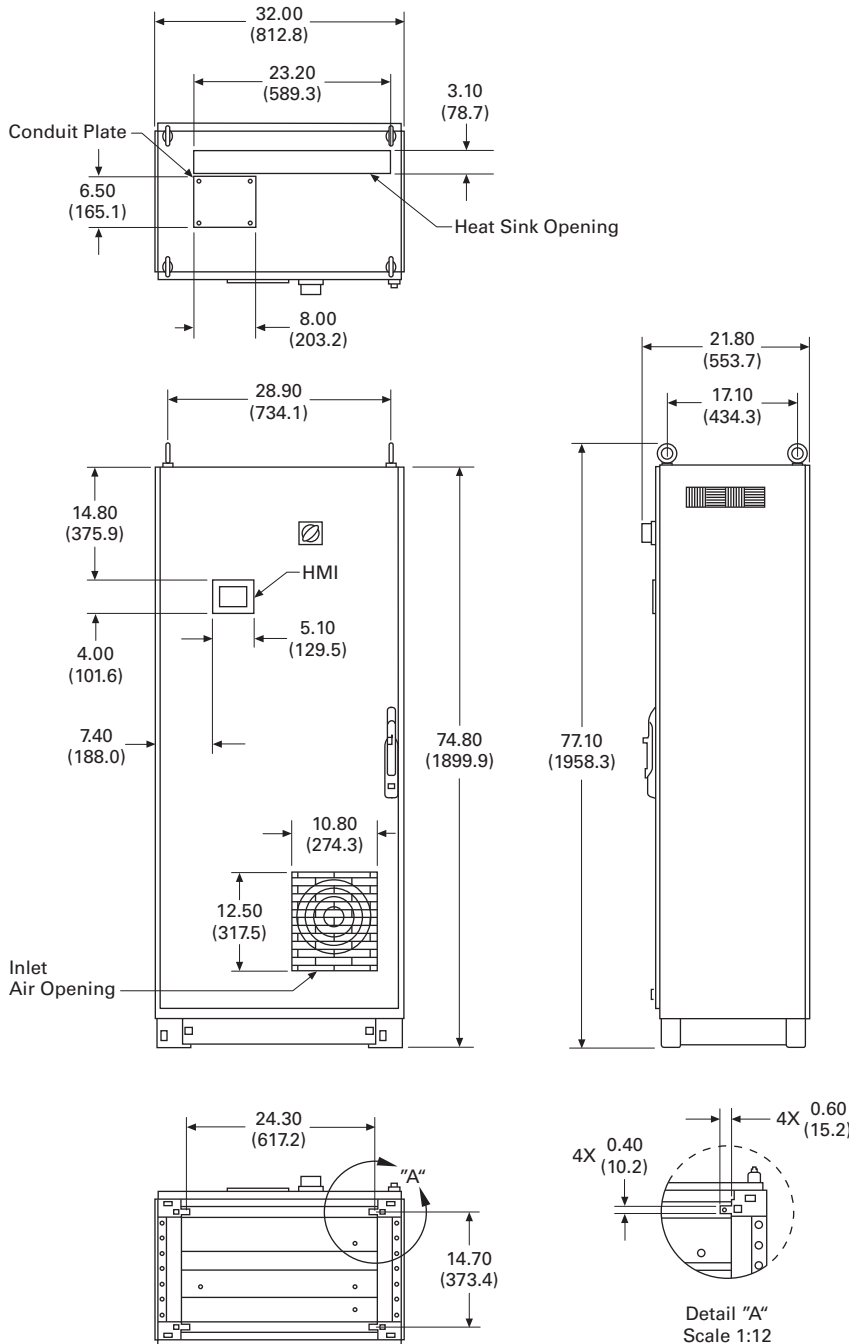

Freedom 2100



Freedom FlashGuard



XT MCC



XTFlashGuard MCC



3.1 MCC Product Offering

Product Overview	V3-T3-2
Product Description	V3-T3-4
Application Description	V3-T3-4
Features, Benefits and Functions	V3-T3-4
Standards and Certifications	V3-T3-4
Accessories and Options	V3-T3-5

3.2 Freedom 2100™ and Freedom FlashGuard® Technical Data and Specifications

Technical Data and Specifications	V3-T3-6
---	---------

3.3 Freedom 2100 and Freedom FlashGuard Check Sheets

Check Sheets	V3-T3-14
--------------------	----------

3.4 XT and XT FlashGuard Technical Data and Specifications

Technical Data and Specifications	V3-T3-18
---	----------

3.5 XT and XT FlashGuard Check Sheets

Check Sheets	V3-T3-26
--------------------	----------



Learn
Online

Freedom 2100 and Freedom FlashGard



Contents

<i>Description</i>	<i>Page</i>
Product Description	V3-T3-4
Application Description	V3-T3-4
Features, Benefits and Functions	V3-T3-4
Standards and Certifications	V3-T3-4
Accessories and Options	V3-T3-5

Product Overview

MCC Operation

Eaton’s motor control center (MCC) product line is headquartered in Fayetteville, NC. At Fayetteville, the most progressive engineering in the industry can custom design motor control for the most demanding applications. Most MCCs can be shipped six to eight weeks after receipt of a released order.

The MCC product line also offers a FAST motor control center (MCC) quick shipment program. The program includes integration of a number of commonly used components and assemblies in MCC applications as well as configuration options for each. The FAST program also includes expedited delivery of customer approval drawings when predefined pilot/control device configurations for unit assemblies are selected. MCCs meeting the FAST criteria are shipped within 4 weeks after receipt of a released order.

Customer Manufacturing and Solutions Centers

One of the most unique aspects of the Eaton MCC operation is the ability to provide customized product to meet delivery requirements through a Customer Manufacturing and Solutions Center (CMSC). There are seven of these facilities located throughout the U.S. serving key geographic markets. Each CMSC has the ability to provide standard NEMA® 1B wired product in as little as one to three days. Please contact the facility in your area to discuss customer opportunities and MCC support for your specific marketplace.

Customer Manufacturing and Solutions Centers

Location	Telephone
Atlanta	678-309-4270
Chicago	630-260-6304
Denver	303-366-9949
Hartford	860-683-4221
Houston	713-939-9696
Los Angeles	562-944-6413
Portland	503-582-2700

Seismic Qualification

The Freedom and XT MCC families have been qualified to meet the seismic requirements of both the Uniform Building Code® (UBC) and the California Building Code (CBC) for equipment operation after seismic activity. This equipment, along with Eaton’s low and medium voltage switchgear assemblies, medium voltage starter assemblies and low voltage switchboards, which meet seismic requirements, provide the user with a complete seismic qualified assemblies package that meet CBC and IBC requirements. Please contact your Eaton sales engineer for more details.

Bid Manager™

One of the most exciting new tools developed for the MCC product line is the Bid Manager program. Bid Manager is a PC-based pricing program that is capable of providing complete bills of material, front views and prices for MCCs. This program can configure an MCC to meet a multitude of specific applications and provide accurate bills of material and front view drawings in a matter of moments. The program operates on a user-friendly, Windows®-based format that offers the most extensive product selection found in the industry. A complete line of adjustable frequency drives and reduced voltage solid-state control, along with insulated case breakers, high ampacity molded case breakers and automatic transfer switches are featured in the program. Control and distribution product can be packaged in a multitude of variations. Please contact your Eaton sales engineer for more details.

Aftermarket Products



Motor Control Center Production Years

2012–Present	2002–2011	1995–present	1992–2010	1987–1995/ 1975–1987	1988–1994	1972–1989	1965–1975	1956–1974	1935–1965
--------------	-----------	--------------	-----------	-------------------------	-----------	-----------	-----------	-----------	-----------

Background

Over 50 years ago, Cutler-Hammer® and Westinghouse® low voltage motor control centers were introduced, enabling the group mounting of low voltage (600V class) electrical controls. This allowed for supervision and safe operation of motor starter units, feeder tap units and auxiliary equipment in a flexible structure arrangement at a centralized location.

The foundation for today’s MCCs is a modular plug-in combination motor controller assembly with components of proven electrical and mechanical integrity. These assemblies are enclosed in metal structures that prevent accidental contact with live electrical parts.

The MCC structure consists of structural steel, horizontal and vertical wireways for conduit and load cable entry and exit, and vertical and horizontal bus systems for distributing power throughout the MCC. The starter unit consists of a rugged steel shell (wrapper) for mounting the unit components, a combination motor starter with factory wired control, a handle mechanism for ON/OFF operation, and a rigid unit door.

Aftermarket Service

Eaton’s Cutler-Hammer series of MCCs are manufactured with high quality structural parts designed to provide many years of service.

Eaton is dedicated to providing replacement units or add-on units to handle additional loads for motor control centers manufactured since 1935 for both the Westinghouse and Cutler-Hammer product lines.

The following descriptions and needed order entry information will be useful in identifying and processing a vintage MCC aftermarket unit.

1. Motor control center type: (11-300, Type W, 5-Star, Advantage, 9800, F-10, FlashGard, Freedom, **IT**, **XT** and **XT** FlashGard)
2. Class of unit (Non-reversing, Reversing, Two Speed)
3. Service voltage
4. Control voltage
5. Starter size or horsepower rating
6. Disconnect type (HMCP, Fusible)
7. Clip size and type (if Fusible)
8. Unit modifications (Lights, Pushbuttons, etc.)
9. Catalog Number (if available)

Product Availability

Replacement units for the 5-Star, Series 2100, Advantage, 11-300, 9800, Type W, F-10, F2100, Freedom FlashGard, **IT**, **IT**. FlashGard, **XT** and **XT** FlashGard motor control center lines may be obtained from the Fayetteville manufacturing plant or any of the regionally located Customer Manufacturing and Solutions Centers (CMSCs).

Competitive MCC units can be obtained from the Fayetteville manufacturing plant or CMSCs.

They are located in:

Customer Manufacturing and Solutions Centers

Location	Telephone
Atlanta	678-309-4270
Chicago	630-260-6304
Denver	303-366-9949
Hartford	860-683-4221
Houston	713-939-9696
Los Angeles	562-944-6413
Portland	503-582-2700

MCC Renewal Parts

MCC Type	Dates	Eaton’s Cutler-Hammer Renewal Parts Publication
XT	2012–present	—
XT FlashGard	2012–present	—
IT .	2002–2011	—
IT . FlashGard	2007–2011	—
F2100	1995–present	RP04304001E
Freedom FlashGard	2008–present	—
Advantage	1992–2011	RP04304002E
Series 2100	1987–1995	RP04304003E
5 Star	1975–1987	RP04304003E
Freedom Unitrol	1988–1994	RP04304004E
F10 Unitrol	1972–1989	RP04304005E
Type W	1965–1975	RP04304006E
9800 Unitrol	1956–1974	RP04304007E
11-300	1935–1965	RP04304008E

Product Description

Eaton’s offering of motor control centers (MCCs) features the Freedom 2100, Freedom FlashGard, **XT** and **XT** FlashGard. These MCCs incorporate the newest NEMA electromechanical starters in the industry along with the most complete, NEMA rated package of distribution and control equipment. The FlashGard MCCs are the industry’s first and only MCCs designed for comprehensive arc flash prevention.

Application Description

Eaton’s MCCs are custom-made assemblies of conveniently grouped control equipment primarily used for control of motors and for distribution of power. MCCs are designed for three-phase, 230V applications up to 300 hp, or three-phase, 480V applications up to 600 hp. The Freedom FlashGard and **XT** FlashGard MCCs are equipped with a state-of-the-art stab racking mechanism (RotoTract™) that provides bus isolation, stab indication and lockout features that proactively prevent the initiation of arc flash.

Features, Benefits and Functions

Structure Design

Eaton’s MCCs are 20.00 inches (508.0 mm) wide and 90.00 inches (2286.0 mm) high with vertical compartments having 72.00 inches (1828.8 mm) of unit mounting space in 6.00-inch (152.4 mm) increments.

Structure depth is 16.00 inches (406.4 mm) or 21.00 inches (533.4 mm) deep front-mounted only and 21.00 inches (533.4 mm) deep for back-to-back mounted units.

The unique framed design permits the highest flexibility in component and structure configuration.

Accessibility

All parts and wiring are front accessible. Terminal blocks are side mounted in each unit. 4.00-inch (101.6 mm) or 8.00-inch (203.2 mm) vertical wireways separate from control units provide safe and convenient access to wiring and conduits without de-energizing any equipment.

Flexibility

Modular, framed design permits structure arrangement to be tailored to exactly meet any control requirements with a minimum of unusable space. Vertical compartments are incremented for maximum space utilization and unit interchangeability. Compact starter and feeder units provide users with the ability to solve demanding space requirements and still meet all NEMA and UL® standards.

Safety

Design tested at Eaton’s power laboratory to ensure maximum protection for control equipment. The FlashGard option ensures maximum safety for personnel working on or around the equipment.

Hardwired Control

With choices for 1A to 2C wiring schemes, the Eaton MCC offers many options for traditional or supervisory control schemes.

Industrial Communications

Eaton MCCs come with the most advanced and flexible industrial factory installed and tested communication connectivity in the marketplace with protocols that include DeviceNet, Modbus and Modbus TCP, EtherNet/IP and PROFIBUS. Eaton smart MCCs facilitate faster startup, safer working conditions and enhanced diagnostics and monitoring.

Intelligent Products

Eaton MCCs include intelligent starters, soft starters, VFDs, meters and feeder breakers that can all be connected to an embedded PLC and operator interface.

Standards and Certifications

UL Listing

Standard structures and units are provided with UL label.

Contact Eaton for details and part numbers for CSA approved units.



Comparison of Key MCC Features and Attributes by MCC Type/Family

MCC Type/ Family	Serves Applications 480V and Below	Serves 600V Applications	Compact Unit Offering Standard ①	Compact Unit Offering Optional ①	120 Vac Control Power	24 Vdc Control Power	FlashGard Technology ②	FlashGard Technology with Test Position ②③	Optional Communications Capability
Freedom	■	■		■	■				■
Freedom FlashGard	■	■			■		■		■
XT	■		■			■			■
XT FlashGard	■					■	■	■	■

Notes

- ① Compact offering has size 1 and 2 FVNR starter units in 1X and size 3 and 4 in 2X. Add 1X to each for FVR versions.
- ② FlashGard technology enables stabs to be retracted from and engaged onto the vertical bus while the unit’s door is closed.
- ③ FlashGard test position enables control power to be delivered to the unit while its stabs are removed from the vertical bus (no line power present within unit).

Accessories and Options

Control and Distribution Equipment Packaging

Eaton's MCCs provide the best packaged solutions for the control needs of today's users. Structural characteristics allow the user to select a complete package of control and distribution equipment in a minimum amount of space. The ability to package a wide range of solid-state products, including SVX9000 drives, S811+ soft starters and PLCs meet the most demanding user process needs. The option to provide high ampacity molded case breakers gives the user the flexibility to minimize switchboard or switchgear structures and thereby saves valuable space and reduces design costs. Additional safety accessories are available such as Motorguard (automatic insulation tester), Voltage Vision (voltage presence indicator), FlashGuard remote racking accessory and FlashGuard locking accessory. Other packaged products, including automatic transfer switches and panelboards, again reduce space requirements and save time and money on equipment and installation costs. A motor load terminal block that enables quick connect/disconnect of 480V power is available as standard on the Freedom FlashGuard as well as the **XT** and **XT** FlashGuard MCCs. This feature is optional on the Freedom 2100 MCC.

FlashGuard Remote Racking Accessory



Remote Racking Accessory

- Performs RotoTract racking safely behind NFPA arc flash boundaries
- 120 Vac motor driven
- Mounts to RotoTract mechanism
- Wired pendant station for "rack-in"/"rack-out" operation
- Momentary jog
- Mounting offset bracket to clear device panel

Voltage Presence Indicator (VoltageVision™)

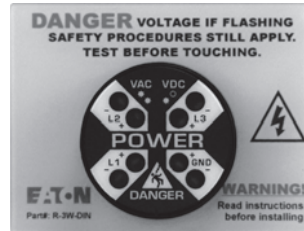

Voltage Presence Indicator (VoltageVision)

- Hardwired voltage detector connected to load side of disconnect
- Enables operator to "pre-verify" voltage presence with unit door closed
- Installable in a 30 mm pilot device knockout
- Dual redundant circuitry for reliability
- Phase insensitive

FlashGuard Locking Accessory

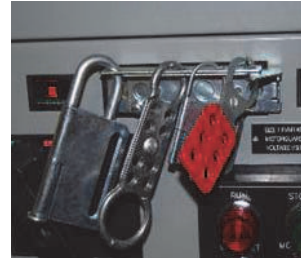

FlashGuard Locking Accessory

- Locks out RotoTract operation during maintenance
- Allows operation of FlashGuard units by authorized personnel only
- Provided as standard on NEMA 12 FlashGuard MCCs (prevents dust entry into RotoTract access port)
- Heavy-gauge steel construction

Automatic Insulation Tester (Motorguard)

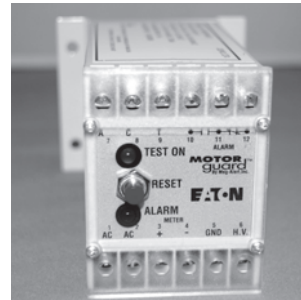

Automatic Insulation Tester (Motorguard)

- "Meggers" equipment motor insulation to continuously monitor integrity of insulation for the period that the equipment is de-energized
- Applies 500 Vdc potential at current-limited, operator-safe maximum amperage of 200 microamperes
- Alarms upon detection of a threshold leakage to ground current
- Visual alarm indication and lockout; Form C contact available for remote alarm status

Technical Data and Specifications

Incoming Line

3

Incoming Line—Main Lugs Only ^①

Bus Rating	X-Space
600	2
	3
	4
800	3
	4
	6
1000	4
	6
	8
1200	5
	6
1600	12
2000	12
2500	12
3200 ^②	12

Incoming Line—Main Circuit Breaker ^①

Frame Size (Amperes)	Circuit Breaker Type	Dimensions in Inches (mm)	
		Freedom and Freedom FlashGard Unit Size	Enclosure Width
150	HFD	18.00 (457.2)	20.00 (508.0)
	FDC	18.00 (457.2)	20.00 (508.0)
225	HFD	18.00 (457.2)	20.00 (508.0)
	FDC	18.00 (457.2)	20.00 (508.0)
250	HJD	30.00 (762.0)	20.00 (508.0)
	JDC	30.00 (762.0)	20.00 (508.0)
400	HKD	30.00 (762.0)	20.00 (508.0)
	KDC	30.00 (762.0)	20.00 (508.0)
	CHKD ^③	30.00 (762.0)	20.00 (508.0)
	CKDC ^③	30.00 (762.0)	20.00 (508.0)
600	HLD	24.00 (609.6) ^{⑥⑧⑨}	20.00 (508.0)
	LDC	24.00 (609.6) ^{⑥⑧⑨}	20.00 (508.0)
	CHLD ^{②③}	24.00 (609.6) ^{⑥⑧⑨}	20.00 (508.0)
	CLDC ^{②③}	24.00 (609.6) ^{⑥⑧⑨}	20.00 (508.0)
800	HMDL	30.00 (762.0) ^{⑥⑨}	20.00 (508.0)
	CHMDL ^{②③}	48.00 (1219.2) ^{⑥⑨}	20.00 (508.0)
	NGH ^{④⑤}	42.00 (1066.8) ^{⑥⑨}	20.00 (508.0)
	NGC ^{④⑤}	42.00 (1066.8) ^{⑥⑨}	20.00 (508.0)
	NGH-C ^{②④⑤⑦}	72.00 (1828.8) ^⑥	20.00 (508.0)
	NGC-C ^{②④⑤}	72.00 (1828.8) ^⑥	20.00 (508.0)
1200	NGH ^{④⑤}	42.00 (1066.8) ^{⑥⑨}	20.00 (508.0)
	NGC ^{④⑤}	42.00 (1066.8) ^{⑥⑨}	20.00 (508.0)
	NGH-C ^{②④⑤⑦}	72.00 (1828.8) ^⑥	20.00 (508.0)
	NGC-C ^{②④⑤}	72.00 (1828.8) ^⑥	20.00 (508.0)
1600	RGH ^{④⑤}	72.00 (1828.8) ^{⑥⑩}	20.00 (508.0)
	RGC ^{④⑤}	72.00 (1828.8) ^{⑥⑩}	20.00 (508.0)
	RGH-C ^{④⑤⑦}	72.00 (1828.8) ^{⑥⑩}	20.00 (508.0)
	RGC-C ^{④⑤⑦}	72.00 (1828.8) ^{⑥⑩}	20.00 (508.0)
2000	RGH ^{④⑤}	72.00 (1828.8) ^{⑥⑩}	20.00 (508.0)
	RGC ^{④⑤}	72.00 (1828.8) ^{⑥⑩}	20.00 (508.0)
	RGH-C ^{④⑤⑦}	72.00 (1828.8) ^{⑥⑩}	20.00 (508.0)
	RGC-C ^{④⑤⑦}	72.00 (1828.8) ^{⑥⑩}	20.00 (508.0)
2500	RGH ^{④⑤}	72.00 (1828.8) ^{⑥⑨⑩}	24.00 (609.6)
	RGC ^{④⑤}	72.00 (1828.8) ^{⑥⑨⑩}	24.00 (609.6)

Notes

- ① Table common to Freedom and Freedom FlashGard.
- ② NEMA 1 gasketed only.
- ③ 100% rated when 90° cable applied at 75° ampacity for 100% rating. Digitrip™ 310 LS is required and included in the price.
- ④ Digitrip 310+ LSI is standard and included in the pricing.
- ⑤ Arcflash Reduction Maintenance System (ARMS) available. Requires Digitrip 310+ ALSI or ALSIG.
- ⑥ Fixed assembly. Not available with FlashGard RotoTract assembly.
- ⑦ 100% rated when 90° cable applied at 75° ampacity for 100% rating.
- ⑧ Add 6.00 inches (152.4 mm) for top entry of incoming cables.
- ⑨ Install at top for cable top entry or at bottom for bottom cable entry.
- ⑩ The main breaker requires the complete vertical section. The rear is unusable.

Structure Modifications

Structure Modifications

Description
Enclosure
NEMA 1 gasketed
NEMA 12—dust-tight
NEMA 3R front-mounted only
NEMA 3R front and rear
NEMA 3R walk-in
NEMA 3R tunnel
Space heater
Thermostat
Bottom plate
Channel sills
12.00-inch (304.8 mm) pull box
100 kA bus bracing
Vertical Bus
600A
800A
1200A
Horizontal Ground Bus
300A copper
600A copper
800A copper
Standard Structures
16.00-inch (406.4 mm) front-mounted only
21.00-inch (533.4 mm) front-mounted only
21.00-inch (533.4 mm) front and rear
Main Horizontal Bus—65°C Rise
600A copper
800A copper
1200A copper
1600A copper
2000A copper
2500A copper
3200A copper
Vertical Bus Barrier
Labyrinth barrier with shutters

Neutral Bus (Bottom)

Ampere Rating
300
600 or 800
1000
1200
1600
2000
2500
3200 ①

Incoming Line Metering

Meter	X-Space Freedom and Freedom FlashGard
IQ 130/140/150	2
IQ 250/260	2
IQ DP-4130	2
IQ Analyzer	2
Power Xpert 2250/2260/2270	2
Power Xpert 4000/6000/8000	3

Surge Protective Device—Units with Circuit Breaker Disconnect

Three feature packages are available to choose from. Individual features vary by package.

Surge Current Per Phase	X-Space Freedom and Freedom FlashGard
100 kA Model SPD ②	3
120 kA Model SPD ②③	3
160 kA Model SPD ②	3
200 kA Model SPD ②	3
250 kA Model SPD ④	3
300 kA Model SPD	3
400 kA Model SPD	3

Notes

- ① Available NEMA 1 gasketed enclosures only.
- ② Optional integral IQ 200 meter in 3X unit for 100 kA–200 kA.
- ③ Recommended for branch entrance.
- ④ Recommended for service entrance.

Combination Starters

Circuit Breaker Starters (HMCP) Non-Reversing (F206) ^①

Size	X-Space	
	F2100	Freedom FlashGard
1	2	2
2	2	2
3	3	3
4	3	4
5	6	7
6	9	9

Compact Circuit Breaker Starters (HMCP) Non-Reversing (F206)

Size	X-Space	
	F2100	
1	1	
2	1	
3	2	
4	2	

Compact Circuit Breaker Starters (HMCP) Reversing (F216)

Size	X-Space	
	F2100	
1	2	
2	2	
3	3	
4	3	

Circuit Breaker Starters ^①

Size	X-Space	
	F2100	Freedom FlashGard
Full Voltage Reversing (F216)		
1	3	3
2	3	3
3	4	4
4	5	5
2S1W (F946)		
1	4	4
2	4	5
3	6	7
4	6	8
2S2W (F956)		
1	4	4
2	4	4
3	5	5
4	5	7
Reduce Voltage Auto Transformer (F606) ^②		
3	8	9
4	8	9
5 ^③	12	12
6 ^④	12	12
Vacuum Starters (V206) Non-Reversing		
4	3	4
5	6	7
6	8	9

Fusible Disconnect Starters ^①

Size	X-Space	
	F2100	Freedom FlashGard
Full Voltage Non-Reversing (F204)		
1	2	3
2	2	3
3	4	4
4	6	6
5	10	11
Full Voltage Reversing (F214)		
1	4	4
2	4	4
3	5	5
4	8	10
Fusible Non-Reversing 2S 1W (F944)		
1	4	4
2	4	5
3	6	6
4	10	10
Fusible Non-Reversing 2S 2W (F954)		
1	4	4
2	4	5
3	5	6
4	8	10

Contactor Only Units

Size	X-Space	
	F2100	Freedom FlashGard
Circuit Breaker (F208)		
1	2	2
2	2	2
3	3	3
4	3	4
5	6	7
6	9	9
Fusible (F209)		
1	2	3
2	2	3
3	4	4
4	6	6
5	10	11

Notes

- ① All starter configurations use the Freedom contactor as standard. It is possible to order the starter configuration with the A200 contactor, which may affect X space.
- ② Must be located at bottom.
- ③ 24.00 inches (609.6 mm) wide.
- ④ 28.00 inches (711.2 mm) wide.

Starter Modifications

Control Options

Description
Selector switch 2/3—Pos.
Push-to-test light 6V transformer
Tx indicating light—standard
Auxiliary switch—in breaker
Mini meters
AMM
VMM
ETM
Relay surge suppressor
Timer—pneumatic
Timer—solid-state
Relay—AR—600V two-pole
Relay—general purpose 300V
Standard solid-state overload relay ^{①②}
NEMA size 1–3
NEMA size 4–6

Industrial Communications ^③

Networked-enabled components in MCCs eliminate up to 90% of the control wiring versus traditional hardwired designs.

The industrial network is prewired throughout the MCC and factory tested for conformance.

Motor Control Communication Options

Device	DeviceNet	Modbus	PROFIBUS	EtherNet/IP	Modbus TCP
C306 Over Load	C441K	C441N	C441S	C441R	C441R
C440 Over Load	C441K	C441N	C441S	C441R	C441R
C441 Over Load	C441K	C441N	C441S	C441R	C441R
SVX Drives	OPTC7	OPTC2	OPTC3	OPTCI	OPTCI
Feeders	C441K	C441N	C441S	C441R	C441R
S811+ Soft Starter	Via gateway	Resident in S811+	Via gateway	C441V	C441V

S811+ Soft Starters with Integral Bypass

Maximum hp	X-Space		Maximum hp	X-Space	
	Freedom	Freedom FlashGard		Freedom	Freedom FlashGard
1.15 Service Factor—Standard Duty			1.15 Service Factor—Severe Duty		
20	2	3	10	2	3
40	2	3	25	2	3
60	3	4	40	3	4
75	3	4	50	3	4
125	6	7	75	6	7
150	6	7	100	6	7
200	6	7	125	6	9
300	9	9	150	9	10
350	9	9	200	9	10
450	12	12	250	9	10
500	12	12	300	9	10
600	12	12	350	9	10
700	12 ^④	12	450	12 ^④	12

S811+ Control Options ^⑤

Description
Pump control
MOV protection

S811+ Power Options ^⑤

NEMA Bypass Contactor
Size 1
Size 2
Size 3
Size 4
Size 5
Size 6
Size 7

Notes

- ① Feature Overload provides same features as standard model plus ground fault, stall/jam protection, selectable trip class —10, 15 and 20.
- ② Size 4 units require additional 6-inch (152.4 mm) (1X) space.
- ③ This table is common for both Freedom 2100 and Freedom FlashGard MCCs.
- ④ Requires 24.00-inch (609.6 mm) wide, rear is unusable, bottom exit only.
- ⑤ Options apply to both HMCP and breaker models.

Motor Isolation Contactors

Sizes
1
2
3
4
5
6
7

MMX Adjustable Frequency Drives—NEMA 1 480V

hp	X-Space	
	Freedom	Freedom FlashGard
1	2	
2	2	
3	3	
5	3	
7.5	3	
10	3	

MMX Drive Options

Description
3% load reactor
5% load reactor
Three contactor bypass

SVX9000 Adjustable Frequency Drives—Plug-in Units NEMA 1 480V Constant/Variable Torque Rated ①

hp	X-Space	
	F2100	Freedom FlashGard
3	3	6
5	4	7
7.5	4	7
10	4	7
15	4	7
20	6	10
25	6	10
30	6	10

SVX9000 Options

Description
DeviceNet communications
PROFIBUS communications
Modbus RTU
Modbus TCP
EtherNet/IP
2000-foot (609.6m) dV/dT filter (3 hp)
2000-foot (609.6m) dV/dT filter (5–15 hp)
2000-foot (609.6m) dV/dT filter (20–30 hp)
Input line fuses (3–30 hp)
RFI filter (3–30 hp)

SVX9000 Adjustable Frequency Drives—Non-Plug-in Units NEMA 1 480V Constant/Variable Torque Rated

hp	X-Space	
	F2100	Freedom FlashGard
40	9	9
50	9	9
60	9	9
75 ②	9	9
100	12	12
125	12	12
150	12	12
200	12	12
250	12	12
300	12	12
400	12	12
500	12	12
600	12	12
700	12	12

Note: Consult *Eaton's Consulting Application Guide* for complete details on Drive/Option Assembly Dimensions.

Note: SVX9000 Non-Plug-in Units with HMCP disconnect, 3% input line reactor, 3% output line reactor, door mounted Keypad, CPT.

Note: VT—Variable Torque drives are capable of producing 200% starting torque for 10 seconds and are rated for 10 seconds, and are rated 110% overload for 1 minute.

Note: CT—Variable Torque drives are capable of producing 200% starting torque for 10 seconds and are rated for 10 seconds, and are rated 150% overload for 1 minute.

SVX9000 Options

Description
DeviceNet communications
PROFIBUS communications
Modbus RTU
Modbus TCP
EtherNet/IP
2000-foot (609.6m) dV/dT filter (40–75 VT hp)
2000-foot (609.6m) dV/dT filter (100–150 VT hp)
2000-foot (609.6m) dV/dT filter (200–250 VT hp)
2000-foot (609.6m) dV/dT filter (300–400 VT hp)
2000-foot (609.6m) dV/dT filter (500–600 VT hp)
Input line fuses (40–150 VT hp)
Input line fuses (200–250 hp)
Input line fuses (300–400 hp)

Active Harmonic Correction for AC Drives

Description	X-Space	
	F2100	Freedom FlashGard
50A harmonic correction	12 ③	12 ③
100A harmonic correction	12 ③	12 ③

18-Pulse Clean Power Drives—NEMA 1, 480V Variable Torque Rated ④

hp	X-Space Inches (mm) Wide ⑤
100	12, 40.00 (1016.0)
150	12, 40.00 (1016.0)
200	12, 60.00 (1524.0)
250	12, 60.00 (1524.0)
300	12, 60.00 (1524.0) ⑥
400	12, 60.00 (1524.0) ⑥
500	12, 106.00 (2692.4) ⑥

Feeders

Note: FlashGard RotoTract assembly available on circuit breakers 400A and below.

Circuit Breaker

Amperes	X-Space	
	F2100	Freedom FlashGard
Standard Circuit Breakers		
HFD 50 ⑦	2	2
HFD 100 ⑦	2	2
HFD 150 ⑦	2	2
HJD 250	3	3
HKD 400	4	5
HLD 600	4	4 ⑧
HND 800	7	7 ⑧
HND 1200	7	7 ⑧
6.00-Inch (152.4 mm) Circuit Breakers		
HFD 50	1	N/A
HFD 100	1	N/A
HFD 150	1	N/A
HFD 225	1	N/A
JDC 250	1	N/A
Dual HFD Circuit Breakers		
50/50	2	⑨
50/100	2	⑨
100/100	2	⑨
100/150	2	⑨
150/150	2	⑨

Fusible Disconnect—Fusible Switch

Amperes	X-Space	
	F2100	Freedom FlashGard
30 or 60	2	3
100	3	3
200	6	5
400	6	7
600	8	8

Fusible Disconnect—Dual Fusible Switch ⑩

Amperes	F2100 X-Space
30	2
60	3
30	2

Notes

- ① SVX9000 plug-in units with HMCP disconnect, 3% input line reactor, 3% output line reactor, door-mounted keypad, CPT.
- ② X-space for 75 hp CT rated drive is 12X.
- ③ Requires 24.00-inch (609.6 mm) wide structure.
- ④ Includes 5% input line reactor, 18-pulse rectifier, delta differential transformer.
- ⑤ X-space shown is common for both F2100 and Freedom FlashGard MCCs.
- ⑥ Extra space required for bypass contactor, consult factory.
- ⑦ HFDE breakers with RMS 310+ electronic trip unit available in 80 AF and 225 AF in 2X space.
- ⑧ Fixed assembly, no RotoTract.
- ⑨ Not available in Freedom FlashGard.

NEMA 3R Drives

480V—Constant/Variable Torque Rated

Horsepower	X-Space Width ^①
1.5	5X, 24.00 (609.6)
2	5X, 24.00 (609.6)
3	5X, 24.00 (609.6)
5	5X, 24.00 (609.6)
7.5	12X, 24.00 (609.6)
10	12X, 24.00 (609.6)
15	12X, 24.00 (609.6)
20	12X, 24.00 (609.6)
25	12X, 24.00 (609.6)
30	12X, 24.00 (609.6)
40	12X, 24.00 (609.6)
50	12X, 32.00 (812.8)
60	12X, 32.00 (812.8)
75	12X, 32.00 (812.8)
100	12X, 32.00 (812.8)
125	12X, 32.00 (812.8)
150	12X, 32.00 (812.8)
200	12X, 32.00 (812.8) ^②

Transformers

Transformers ^③

kVA	Primary Breaker Only X-Space	Primary and Secondary Breakers X-Space
Single-Phase		
3	4	4
5	4	4
7.5	4	4
10	4	4
15 ^⑤	6	6
20 ^⑥	6	6
25 ^⑥	6	6
30 ^⑥	6	6
45 ^⑥	7	8
Three-Phase		
9 ^⑥	6	6
15 ^⑥	6	6
25 ^⑥	6	6
30 ^⑥	6	6
45 ^⑥	6	6

Panelboards

Panelboards (240V Maximum) ^{①④}

Circuits	X-Space
18	4
30	5
42	6

Panelboards (480V Maximum) ^{①④}

Circuits	X-Space
14	6
26	8
32	8
42	10

Automatic Transfer Switches

Open Transition Three-Pole Only

Ampere Rating	Unit Width Inches (mm)	Freedom and Freedom FlashGuard X-Space
100 ^⑤	20.00 (508.0)	6
150 ^⑤	20.00 (508.0)	6
100	20.00 (508.0)	8
150	20.00 (508.0)	8
225	20.00 (508.0)	8
300	20.00 (508.0)	8
400	24.00 (609.6) ^⑥	12
600	24.00 (609.6) ^⑥	12
800	24.00 (609.6) ^⑥	12
1000	24.00 (609.6) ^⑥	12
1000	44.00 (1117.6) ^⑦	12
1200	44.00 (1117.6) ^⑦	12
1600	44.00 (1117.6) ^⑧	12
2000	44.00 (1117.6) ^⑧	12

Notes

- ① X-space shown is common for both Freedom and Freedom FlashGuard MCCs.
- ② Extra space required for bypass section. Consult factory.
- ③ Must have primary breaker. Must be located at bottom of structure.
- ④ Space for MLO. Branch breakers included.
- ⑤ Manually operated switch:
NTVS = Electronically operated non-automatic.
MTVX = Single handle manual operation.
- ⑥ Requires 21.00-inch (533.4 mm) deep structure.
- ⑦ Requires 37.00-inch (939.8 mm) deep structure, flush at the rear. 4.00-inch (101.6 mm) filler required.
- ⑧ Requires 42.00-inch (1066.8 mm) deep structure. 4.00-inch (101.6 mm) filler required.

Application Guide

Motor Circuit Protector Selection Guide ^①

NEMA	Maximum Horsepower						
	200V	208V	230V	380V	460V	575V	HMCP
1	—	—	—	3/4	3/4	1	3
	3/4	1	1	2	2	3	7
	2	2	2	3	5	7-1/2	15
	5	5	5	10	10	10	30
2	7-1/2	7-1/2	7-1/2	—	—	—	50
	—	—	—	—	—	15	30
	10	10	10	15	20	25	50
	—	—	15	25	25	—	70
3	—	—	—	—	—	30	50
	15	20	20	30	40	50	100
	25	25	30	50	50	—	150
4	40	40	40	60	100	100	150
	—	—	50	75	—	—	250
5	50	50	60	—	125	150	250
	75	75	75	150	200	200	400
	—	—	100	—	—	—	600
6	150	150	200	300	350	400	600
	—	—	—	—	400	—	1200

Circuit Breaker Application Chart

Frame	Frame Rating (Amperes)	Interrupting Rating (kA Symmetrical Amperes)		
		208/240V	480V	600V
Standard Rating Molded Case Circuit Breakers				
HFD	150	65	65	25
HJD	250	65	65	25
HKD	400	65	65	35
HLD	600	65	65	35
NGH	800	65	65	35
NGH	1200	65	65	35
RGH	2000	65	65	50
High Interrupting Rating Molded Case Circuit Breakers				
FDC	150	100	100	35
JDC	250	100	100	35
KDC	400	100	100	50
LDC	600	100	100	50
NGC	800	100	100	50
NGC	1200	100	100	50
RGC	2000	100	100	65
RGC	2500	100	100	65
Current Limiting Molded Case Circuit Breakers				
HFD/CL	150	100	100	100
NBTRIPAC	300–800	100	100	100
Magnum DS Air Circuit Breakers				
MDS-608	800	65	65	65
MDS-C08	800	100	100	100
MDS-616	1600	65	65	65
MDS-C16	1600	100	100	100
MDS-620	2000	65	65	65
MDS-C20	2000	100	100	100
MDS-632	3200	65	65	65
MDS-C32	3200	100	100	100

Notes

^① Suitable for use with NEMA Design B and D (high efficiency) motors.
Circuit breakers can be supplied with optional CPT and optional shunt trip.

Individual CPT Sizes

Starter Size	Standard Transformer (VA)	Maximum Size in Standard Unit (VA)
FVNR, FVR, 2S2W		
1, 2	100	150
1, 2-6	100	100
3, 4	150	250
5, 6	500	500
4	150	250
5	150	250
6	250	350
RVAT		
3, 4	150	250
5, 6	500	500
2S1W		
1, 2, 3, 4	200	250
5, 6	500	500
Vacuum		
4	150	250
5	150	250
6	250	350

Product Specifications

Structure

- NEMA 1, 2, 3R or 12 enclosure
- Copper horizontal bus 600–3200A
- Fully rated copper vertical bus 300–1200A
- Isolated vertical bus barrier standard on Freedom 2100 MCCs
- Optional insulated horizontal bus and/or insulated labyrinth vertical bus on Freedom 2100 MCCs
- Optional isolating barriers between structures
- Insulated horizontal bus and insulated labyrinth vertical bus is standard on FlashGard MCCs
- Heavy-duty spring operated quarter-turn door latches
- 65 kA and 100 kA bus bracing

Units

- Freedom 2100 Motor Starters:
 - NEMA size 1–7
 - Bimetallic overload relay
 - Single-phase protection
 - Class 10 and 20 protection
 - Widest heater range with fewest styles in the industry
 - Optional solid-state overload relays
- HMCP with combination starter ratings of 65 kAIC and 100 kAIC at 480V
- Plug-in units up to 400A
- Handle mechanism with positive trip indication
- Side-mounted positive latch terminal block

- Motor load terminal block is standard on FlashGard MCC and optional on Freedom 2100
- Compact units available
- Solid-State Reduced Voltage Starters:
 - S811+ (20–800 hp)
- Adjustable Frequency Drives:
 - MVX (1–10 hp)
 - SVX9000 (2–600 hp)
- K-Switch visible blade fused disconnect:
 - 30–800A
 - 100 kAIC at 600V
- 10250T 30.5 mm heavy-duty oiltight pushbuttons
- Surge protection:
 - SPD Series (100–400 kA)
- Energy monitoring:
 - IQ 100 (amperes, volts)
 - IQ 250 (adds, Hz, watts, PF)
 - IQ 260 (adds THD, Contact I/O)
 - IQ Analyzer (adds trending, waveform display)
 - Power Xpert (adds high-end metering, power quality analysis, open communications and Web server gateway)

Freedom 2100 and Freedom FlashGard



Contents

Description

Freedom 2100 and Freedom FlashGard Check Sheets

Motor Control Center Takeoff Check Sheet

Customer/Job Name	Neg No.
MCC Model	
Freedom 2100	FlashGard
Service 60 Hz	208V/230V/ 480V /575V
Voltage 50 Hz	380V/415V
DC	125V/250V
Three-wire /four-wire	
Structure Configuration	
16-inch front mount	21-inch front mount
21-inch front and rear mount	
42-inch front mount back-to-back	
32-inch front mount back-to-back	
NEMA 1A /2DP/12/3RNWI/3R aisle/3R tunnel	
Enclosure Modifications	
Space heaters (150W) 120V/240V	
Channel sills	CBC/IBC seismic qualified
Thermostat	Split proof
Bottom plates	Split rear cover
Corner structure	Vertical section barrier
8-inch vertical wireway	Special paint color (adder)
	ABS Certification
Handle extensions ("two meter rule")	
Top hat (certain sections)	12-inch/18-inch/24-inch
Top hat (all sections)	12-inch/18-inch/24-inch

Bus Rating and Options	
Horizontal bus	600 /800/1200/1600
21-inch deep structure only	2000/2500/3200
Bus plating	Silver (AG)/ tin (SN)
Bus temp rise	50°C/ 65°C
Insulated horizontal bus	
Vertical bus	600/800/1200
Ground bus	300/600/800
Location	Top /bottom
Vertical ground bus	Lugs: incoming /each end
Neutral bus (4W only)	Half/full/ lug pad
Bus bracing	42K/ 65K /100K
Vertical bus barrier	STD Glastic sheet
	Labyrinth with/without shutter
Incoming Line Metering	
IQ 130/140/150	
IQ 250/260	
IQ DP-4130	
IQ Analyzer	
Power Xpert 2250/2260/2270	
Power Xpert 4000/6000/8000	
Incoming Protection	
SPD Series surge protective device	
Incoming Line MLO/Breaker/Switch	
Cable—top/bottom/bus duct	
Main trip: LS/LSI/LSG/LSIG/other	
Crimp lugs	Screw type lugs
Main tie main (MTM)	Auto throw over
Kirk key	Service entrance (SUSE)

MCC Spec Review Checklist, continued

Breaker Options	
Aux. contacts (1NO 1NC) (2NO 2NC)	
LS/LSI/LSIG/LSG trip units	
Under voltage release	Shunt trip
Panelboards	
14/18/26/30/32/42 count	1-pole/2-pole/3-pole
Starter Disconnect Type	
HMCP/TM. bkr./fusible	
NEMA wiring class	
1A/1B/2B/1C/2C/1S/2S	
HMCP/TM. Bkr./fusible	
If any type "C" choose MTB location: Master terminal blocks (MTBs) top/bottom/relay structure	
Terminal Blocks	
Side latch pull apart (Std) (2x7-point)	
Spare points = _____% (call DSE)	Front utility (call DSE)
Nameplates: Black with White Letters / White with Black Letters	
Starter OL Types	
Bimetallic	Advanced solid-state
Solid-state	
Plug-In Starter Bucket Unit Features	
# 16 MTW wire	Coil surge suppression
# 14 SIS wire	Blown fuse indicators
# 14 MTW	Ground fault relays
Wiremarkers each end	
Ring wire lugs control	Riley current sensor
Spade wire lugs	Heater packs
Ring power wire lugs	
Wiring diagram on door	
SIS power wire	Vacuum contactors

Control Power	
Size 1 100 VA (Std)/150 VA max.	
Size 2 100 VA (Std)/150 VA max.	
Size 3 150 VA (Std)/250 VA max.	
Size 4 150 VA (Std)/250 VA max.	
Size 5 250 VA (Std)/300 VA max.	
Size 6 250 VA (Std)/300 VA max.	
Separate source power	
Auxiliary Starter Contacts	
NO 1/2/3/4	NC 1/2/3/4
Control Devices	
Pushbutton 1 unit/2 unit/reset	VoltageVision
Selector switch 2pos/3pos/4pos	Motorguard
Light—Std Xfmr/PTT/LED bulb	Motor load block
On/off run/stop	
Mini ETM	Panel ETM
AMM (mini/panel)	VM (mini/panel)
Riley transducer (Loop/Self Pwr)	
CTs for remote metering	
Ground fault	
IP relay—size 1/2/3/4/5/6	Voltage=
Relays 300V or 600V	Timers
Communications	
DeviceNet direct	Modbus RTU
Ethernet	Power Xpert Gateway
Modbus TCP	PROFIBUS DP
S811+ Soft Starters	
Isolation contactor	MOVs
Pump control software	Bypass starter
VFDs	
EMI/RFI	SVX/MVX/CPX
dV/dT filter 600 ft or 1000 ft	3-contactor bypass
Harmonic Correction Unit	
50A/100A	

3.3

Motor Control Centers

Freedom 2100 and Freedom FlashGuard Check Sheets

3

Component Count Sheet

FVNR Starters		FVR Starters	
Size	Quantity	Size	Quantity
1		1	
2		2	
3		3	
4		4	
5		5	
6		6	
7			

Feeder Breakers			
Single	Quantity	Dual	Quantity
50A		50/50	
100A		100/50	
150A		100/100	
225A		150/100	
250A		150/150	
400A			
600A			
800A			
1200A			
1600A			
2000A			
2500A			
3200A			

VFDs		
HP	Quantity	Type
1.5		CT/VT
2		CT/VT
3		CT/VT
5		CT/VT
7.5		CT/VT
10		CT/VT
20		CT/VT
25		CT/VT
30		CT/VT
40		CT/VT
50		CT/VT
60		CT/VT
75		CT/VT
100		CT/VT
125		CT/VT
150		CT/VT
200		CT/VT
250		CT/VT
300		CT/VT
400		CT/VT
500		CT/VT
600		CT/VT
700		CT/VT

Two Speed, One Winding		Two Speed, Two Winding	
Size	Quantity	Size	Quantity
1		1	
2		2	
3		3	
4		4	

Fusible Feeders			
Single	Quantity	Dual	Quantity
30A		30/30	
60A		60/60	
100A			
200A			
400A			
600A			
800A			
1200A			

Starter Circuit Protection		Future Space	
		Size	Quantity
HMCP	Thermal Magnetic	2X	
HMCPE		3X	
Fusible		4X	

Relay Panels	
Size	Quantity
2X	
3X	
4X	
5X	
6X	
7X	
8X	
9X	
10X	
11X	
12X	

Component Count Sheet, continued

Soft Starters

HP	Quantity	Duty	Cable Exit
20		Std/severe	
40		Std/severe	
60		Std/severe	
75		Std/severe	
125		Std/severe	
200		Std/severe	
300		Std/severe	Top/bottom
350		Std/severe	Top/bottom
450		Std/severe	Top/bottom
500		Std/severe	Top/bottom
600		Std/severe	Top/bottom
700		Std/severe	Top/bottom

Transformers

Single-Phase	Quantity	Three-Phase	Quantity
3 kVA		9 kVA	
5 kVA		15 kVA	
7.5 kVA		25 kVA	
10 kVA		30 kVA	
15 kVA		45 kVA	
20 kVA			
25 kVA			
30 kVA			
45 kVA			

Technical Data and Specifications

Incoming Line

3

Incoming Line—Main Lugs Only ^①

Bus Rating	X-Space
600	2
	3
	4
800	3
	4
	6
1000	4
	6
	8
1200	5
	6
1600	12
2000	12
2500	12
3200 ^②	12

Incoming Line—Main Circuit Breaker ^①

Frame Size (Amperes)	Circuit Breaker Type	Dimensions in Inches (mm)	
		XT and XT FlashGard Unit Size	Enclosure Width
150	HFD	18.00 (457.2)	20.00 (508.0)
	FDC	18.00 (457.2)	20.00 (508.0)
225	HFD	18.00 (457.2)	20.00 (508.0)
	FDC	18.00 (457.2)	20.00 (508.0)
250	HJD	30.00 (762.0)	20.00 (508.0)
	JDC	30.00 (762.0)	20.00 (508.0)
400	HKD	30.00 (762.0)	20.00 (508.0)
	KDC	30.00 (762.0)	20.00 (508.0)
	CHKD ^③	30.00 (762.0)	20.00 (508.0)
	CKDC ^③	30.00 (762.0)	20.00 (508.0)
600	HLD	24.00 (609.6) ^{⑥⑧⑨}	20.00 (508.0)
	LDC	24.00 (609.6) ^{⑥⑧⑨}	20.00 (508.0)
	CHLD ^{②③}	24.00 (609.6) ^{⑥⑧⑨}	20.00 (508.0)
	CLDC ^{②③}	24.00 (609.6) ^{⑥⑧⑨}	20.00 (508.0)
800	HMDL	30.00 (762.0) ^{⑥⑨}	20.00 (508.0)
	CHMDL ^{②③}	48.00 (1219.2) ^{⑥⑨}	20.00 (508.0)
	NGH ^{④⑤}	42.00 (1066.8) ^{⑥⑨}	20.00 (508.0)
	NGC ^{④⑤}	42.00 (1066.8) ^{⑥⑨}	20.00 (508.0)
	NGH-C ^{②④⑤⑦}	72.00 (1828.8) ^⑥	20.00 (508.0)
	NGC-C ^{②④⑤}	72.00 (1828.8) ^⑥	20.00 (508.0)
1200	NGH ^{④⑤}	42.00 (1066.8) ^{⑥⑨}	20.00 (508.0)
	NGC ^{④⑤}	42.00 (1066.8) ^{⑥⑨}	20.00 (508.0)
	NGH-C ^{②④⑤⑦}	72.00 (1828.8) ^⑥	20.00 (508.0)
	NGC-C ^{②④⑤}	72.00 (1828.8) ^⑥	20.00 (508.0)
1600	RGH ^{④⑤}	72.00 (1828.8) ^{⑥⑩}	20.00 (508.0)
	RGC ^{④⑤}	72.00 (1828.8) ^{⑥⑩}	20.00 (508.0)
	RGH-C ^{④⑤⑦}	72.00 (1828.8) ^{⑥⑩}	20.00 (508.0)
	RGC-C ^{④⑤⑦}	72.00 (1828.8) ^{⑥⑩}	20.00 (508.0)
2000	RGH ^{④⑤}	72.00 (1828.8) ^{⑥⑩}	20.00 (508.0)
	RGC ^{④⑤}	72.00 (1828.8) ^{⑥⑩}	20.00 (508.0)
	RGH-C ^{④⑤⑦}	72.00 (1828.8) ^{⑥⑩}	20.00 (508.0)
	RGC-C ^{④⑤⑦}	72.00 (1828.8) ^{⑥⑩}	20.00 (508.0)
2500	RGH ^{④⑤}	72.00 (1828.8) ^{⑥⑨⑩}	24.00 (609.6)
	RGC ^{④⑤}	72.00 (1828.8) ^{⑥⑨⑩}	24.00 (609.6)

Notes

- ① Table common to XT and XT FlashGard.
- ② NEMA 1 gasketed only.
- ③ 100% rated when 90° cable applied at 75° ampacity for 100% rating. Digitrip™ 310 LS is required and included in the price.
- ④ Digitrip 310+ LSI is standard and included in the pricing.
- ⑤ Arcflash Reduction Maintenance System (ARMS) available. Requires Digitrip 310+ ALSI or ALSIG.
- ⑥ Fixed assembly. Not available with FlashGard RotoTract assembly.
- ⑦ 100% rated when 90° cable applied at 75° ampacity for 100% rating.
- ⑧ Add 6.00 inches (152.4 mm) for top entry of incoming cables.
- ⑨ Install at top for cable top entry or at bottom for bottom cable entry.
- ⑩ The main breaker requires the complete vertical section. The rear is unusable.

Structure Modifications

Structure Modifications

Description
Enclosure
NEMA 1 gasketed
NEMA 12—dust-tight
NEMA 3R front-mounted only
NEMA 3R front and rear
NEMA 3R walk-in
NEMA 3R tunnel
Space heater
Thermostat
Bottom plate
Channel sills
12.00-inch (304.8 mm) pull box
100 kA bus bracing
Vertical Bus
600A
800A
1200A
Horizontal Ground Bus
300A copper
600A copper
800A copper
Standard Structures
16.00-inch (406.4 mm) front-mounted only
21.00-inch (533.4 mm) front-mounted only
21.00-inch (533.4 mm) front and rear
Main Horizontal Bus—65°C Rise
600A copper
800A copper
1200A copper
1600A copper
2000A copper
2500A copper
3200A copper

Neutral Bus (Bottom)

Ampere Rating
300
600 or 800
1000
1200
1600
2000
2500
3200 ①

Incoming Line Metering

Meter	X-Space XT and XT FlashGard
IQ 130/140/150	2
IQ 250/260	2
IQ DP-4130	2
IQ Analyzer	2
Power Xpert 2250/2260/2270	2
Power Xpert 4000/6000/8000	3

**Surge Protective Device—
Units with Circuit Breaker
Disconnect**

Three feature packages are available to choose from. Individual features vary by package.

Surge Current Per Phase	X-Space XT and XT FlashGard
100 kA Model SPD ②	3
120 kA Model SPD ②③	3
160 kA Model SPD ②	3
200 kA Model SPD ②	3
250 kA Model SPD ④	3
300 kA Model SPD	3
400 kA Model SPD	3

Notes

- ① Available NEMA 1 gasketed enclosures only.
- ② Optional integral IQ 200 meter in 3X unit for 100 kA–200 kA.
- ③ Recommended for branch entrance.
- ④ Recommended for service entrance.

Combination Starters

Circuit Breaker Starters

Size	X-Space	
	XT	XT FlashGard
Full Voltage Non-Reversing		
1	1	2
2	1	2
3	2	3
4	2	4
5	5	6
Full Voltage Reversing		
1	2	3
2	2	3
3	3	4
4	3	4
5	7	8
2S1W Non-Reversing		
1	3	4
2	3	4
3	4	5
4	4	5
2S2W Non-Reversing		
1	3	4
2	3	4
3	3	4
4	4	5

Fusible Disconnect Starters

Size	X-Space	
	XT	XT FlashGard
Full Voltage Non-Reversing		
1	2	3
2	2	3
3	4	4
4	5	6
5	9	10
Full Voltage Reversing		
1	3	4
2	3	4
3	5	6
4	8	9
5	12	12
2S1W Non-Reversing		
1	3	4
2	3	4
3	4	5
4	5	6
2S2W Non-Reversing		
1	3	4
2	3	4
3	5	6
4	6	7

Contactors Only Units

Size	X-Space	
	XT	XT FlashGard
Circuit Breaker		
1	1	2
2	1	2
3	2	3
4	2	4
5	5	6
Fusible Disconnect		
1	2	3
2	2	3
3	4	4
4	5	6
5	9	10

Starter Modifications

Control Configurations Available with XT and XT FlashGard FVNR Starters ^①

Configuration	Control Devices
1 ^②	Hand/off/auto selector switch Start and stop pushbuttons Running and stopped lights Overload trip light/reset button
2 ^②	Hand/off/auto selector switch Start and stop pushbuttons Running light Overload trip light/reset button
3	Hand/off/auto selector switch Running and stopped lights Overload trip light/reset button
4	Hand/off/auto selector switch Running light Overload trip light/reset button
5	Hand/off/auto selector switch Overload trip light/reset button
6 ^②	Start and stop pushbuttons Running and stopped lights Overload trip light/reset button
7	Start and stop pushbuttons Running light Overload trip light/reset button
8	Start and stop pushbuttons Overload trip light/reset button

Control Configurations Available with XT and XT FlashGard FVR Starters ^①

Configuration	Control Devices
1 ^②	Forward/reverse/off/auto selector switch Forward, reverse, and stopped lights Overload trip light/reset button
2	Forward/reverse/off/auto selector switch Forward and reverse lights Overload trip light/reset button
3	Forward/reverse/off/auto selector switch Overload trip light/reset button
5 ^②	Forward, reverse, and stop pushbuttons Forward and reverse lights Overload trip light/reset button
4	Forward, reverse, and stop pushbuttons Overload trip light/reset button

Notes

^① Additional configurations available. The device panel on **XT** MCC starter units can support up to three pilot/control devices plus an overload trip light/reset button. The device panel on **XT** FlashGard starter units can support up to five pilot/control devices plus an overload trip light/reset button.

^② Configuration available on **XT** FlashGard only.

Industrial Communications ①

Networked-enabled components in MCCs eliminate up to 90% of the control wiring versus traditional hardwired designs. The industrial network is prewired throughout the MCC and factory tested for conformance.

In the **XT** and **XT FlashGard** MCCs, the base communications protocols available are Modbus TCP or EtherNet/IP. If a different protocol is required to link the MCC with an external device such as a DCS, SCADA system or PLC, a gateway will be installed within the MCC.

Motor Control Communication Options

Device	EtherNet/IP	Modbus TCP
C440 Overload	C441V	C441V
SVX Drives	OPTCI	OPTCI
Feeders	C441V	C441V
S811+ Soft Starters	C441V	C441V

S811+ Soft Starters with Integral Bypass

Maximum hp	X-Space		Maximum hp	X-Space	
	XT	XTFlashGard		XT	XTFlashGard
1.15 Service Factor—Standard Duty			1.15 Service Factor—Severe Duty		
20	2	3	10	2	3
40	2	3	25	2	3
60	3	4	40	3	4
75	3	4	50	3	4
125	6	7	75	6	7
150	6	7	100	6	7
200	6	7	125	6	9
300	9	9	150	9	10
350	9	9	200	9	10
450	12	12	250	9	10
500	12	12	300	9	10
600	12	12	350	9	10
700	12 ②	12	450	12 ②	12

S811+ Control Options ③

Description
Pump control
MOV protection

S811+ Power Options ③

NEMA Bypass Contactor
Size 1
Size 2
Size 3
Size 4
Size 5
Size 6
Size 7

Notes

- ① This table is common for both **XT** and **XT FlashGard** MCCs.
- ② Requires 24.00-inch (609.6 mm) wide, rear is unusable, bottom exit only.
- ③ Options apply to both HMCP and breaker models.

Motor Isolation Contactors

Sizes
1
2
3
4
5

MMX Adjustable Frequency Drives—NEMA 1 480V

hp	X-Space	
	XT	XT FlashGard
1	2	
2	2	
3	3	
5	3	
7.5	3	
10	3	

MMX Drive Options

Description
3% load reactor
5% load reactor
Three contactor bypass

SVX9000 Adjustable Frequency Drives—Plug-in Units NEMA 1 480V Constant/Variable Torque Rated ①

hp	X-Space	
	XT	XT FlashGard
3	3	6
5	4	7
7.5	4	7
10	4	7
15	4	7
20	6	10
25	6	10
30	6	10

SVX9000 Options

Description
Modbus TCP
EtherNet/IP
2000-foot (609.6m) dV/dT filter (3 hp)
2000-foot (609.6m) dV/dT filter (5–15 hp)
2000-foot (609.6m) dV/dT filter (20–30 hp)
Input line fuses (3–30 hp)
RFI filter (3–30 hp)

SVX9000 Adjustable Frequency Drives—Non-Plug-in Units NEMA 1 480V Constant/Variable Torque Rated

hp	X-Space	
	XT	XT FlashGard
40	9	9
50	9	9
60	9	9
75 ②	9	9
100	12	12
125	12	12
150	12	12
200	12	12
250	12	12
300	12	12
400	12	12
500	12	12
600	12	12
700	12	12

Note: Consult *Eaton's Consulting Application Guide* for complete details on Drive/Option Assembly Dimensions.

Note: SVX9000 Non-Plug-in Units with HMCP disconnect, 3% input line reactor, 3% output line reactor, door mounted Keypad, CPT.

Note: VT—Variable Torque drives are capable of producing 200% starting torque for 10 seconds and are rated for 10 seconds, and are rated 110% overload for 1 minute.

Note: CT—Variable Torque drives are capable of producing 200% starting torque for 10 seconds and are rated for 10 seconds, and are rated 150% overload for 1 minute.

Note: In the XT and XT FlashGard MCCs, the base communications protocols available are Modbus TCP or EtherNet/IP. If a different protocol is required to link the MCC with an external device such as a DCS, SCADA or PLC, a gateway will be installed within the MCC.

SVX9000 Options

Description
Modbus TCP
EtherNet/IP
2000-foot (609.6m) dV/dT filter (40–75 VT hp)
2000-foot (609.6m) dV/dT filter (100–150 VT hp)
2000-foot (609.6m) dV/dT filter (200–250 VT hp)
2000-foot (609.6m) dV/dT filter (300–400 VT hp)
2000-foot (609.6m) dV/dT filter (500–600 VT hp)
Input line fuses (40–150 VT hp)
Input line fuses (200–250 hp)
Input line fuses (300–400 hp)

Active Harmonic Correction for AC Drives

Description	X-Space	
	XT	XT FlashGard
50A harmonic correction	12 ③	12 ③
100A harmonic correction	12 ③	12 ③

18-Pulse Clean Power Drives—NEMA 1, 480V Variable Torque Rated ④

hp	X-Space Inches (mm) Wide ⑤	
100	12, 40.00 (1016.0)	
150	12, 40.00 (1016.0)	
200	12, 60.00 (1524.0)	
250	12, 60.00 (1524.0)	
300	12, 60.00 (1524.0) ⑥	
400	12, 60.00 (1524.0) ⑥	
500	12, 106.00 (2692.4) ⑥	

Feeders

Note: FlashGard RotoTract assembly available on circuit breakers 400A and below.

Circuit Breaker

Amperes	X-Space	
	XT	XT FlashGard
Standard Circuit Breakers		
HFD 50	2	2
HFD 100	2	2
HFD 150	2	2
HJD 250	3	3
HKD 400	4	5
HLD 600	4	4 ⑦
NGH 800	7	7 ⑦
NGH 1200	7	7 ⑦
EGH 125	1	2
JGH 250	1	2
HKD 400	4	5
HLD 600	5	5 ⑦

Fusible Disconnect—Fusible Switch

Amperes	X-Space	
	XT	XT FlashGard
30 or 60	2	3
100	3	3
200	6	5
400	6	7
600	8	8 ⑦

Notes

- ① SVX9000 plug-in units with HMCP disconnect, 3% input line reactor, 3% output line reactor, door-mounted keypad, CPT.
- ② X-space for 75 hp CT rated drive is 12X.
- ③ Requires 24.00-inch (609.6 mm) wide structure.
- ④ Includes 5% input line reactor, 18-pulse rectifier, delta differential transformer.
- ⑤ X-space shown is common for both F2100 and Freedom FlashGard MCCs.
- ⑥ Extra space required for bypass contactor, consult factory.
- ⑦ Fixed assembly, no RotoTract.

NEMA 3R Drives

480V—Constant/Variable Torque Rated

Horsepower	X-Space, Width Inches (mm) ^①
1.5	5X, 24.00 (609.6)
2	5X, 24.00 (609.6)
3	5X, 24.00 (609.6)
5	5X, 24.00 (609.6)
7.5	12X, 24.00 (609.6)
10	12X, 24.00 (609.6)
15	12X, 24.00 (609.6)
20	12X, 24.00 (609.6)
25	12X, 24.00 (609.6)
30	12X, 24.00 (609.6)
40	12X, 24.00 (609.6)
50	12X, 32.00 (812.8)
60	12X, 32.00 (812.8)
75	12X, 32.00 (812.8)
100	12X, 32.00 (812.8)
125	12X, 32.00 (812.8)
150	12X, 32.00 (812.8)
200	12X, 32.00 (812.8) ^②

Transformers

Transformers ^③

kVA	Primary Breaker Only X-Space	Primary and Secondary Breakers X-Space
Single-Phase		
3	4	4
5	4	4
7.5	4	4
10	4	4
15 ^⑥	6	6
20 ^⑥	6	6
25 ^⑥	6	6
30 ^④	6	6
45 ^⑥	7	8
Three-Phase		
9 ^⑥	6	6
15 ^⑥	6	6
25 ^⑥	6	6
30 ^⑥	6	6
45 ^⑥	6	6

Panelboards

Panelboards (240V Maximum) ^{①④}

Circuits	X-Space
18	4
30	5
42	6

Panelboards (480V Maximum) ^{①④}

Circuits	X-Space
14	6
26	8
32	8
42	10

Automatic Transfer Switches

Open Transition Three-Pole Only

Ampere Rating	Unit Width Inches (mm)	XT and XT FlashGard X-Space
100 ^⑤	20.00 (508.0)	6
150 ^⑤	20.00 (508.0)	6
100	20.00 (508.0)	8
150	20.00 (508.0)	8
225	20.00 (508.0)	8
300	20.00 (508.0)	8
400	24.00 (609.6) ^⑥	12
600	24.00 (609.6) ^⑥	12
800	24.00 (609.6) ^⑥	12
1000	24.00 (609.6) ^⑥	12
1000	44.00 (1117.6) ^⑦	12
1200	44.00 (1117.6) ^⑦	12
1600	44.00 (1117.6) ^⑧	12
2000	44.00 (1117.6) ^⑧	12

Notes

- ① X-space shown is common for both XT and XT FlashGard MCCs.
- ② Extra space required for bypass section. Consult factory.
- ③ Must have primary breaker. Must be located at bottom of structure.
- ④ Space for MLO. Branch breakers included.
- ⑤ Manually operated switch:
NTVS = Electronically operated non-automatic.
MTVX = Single handle manual operation.
- ⑥ Requires 21.00-inch (533.4 mm) deep structure.
- ⑦ Requires 37.00-inch (939.8 mm) deep structure, flush at the rear. 4.00-inch (101.6 mm) filler required.
- ⑧ Requires 42.00-inch (1066.8 mm) deep structure. 4.00-inch (101.6 mm) filler required.

Application Guide

Motor Circuit Protector Selection Guide ^①

NEMA	Maximum Horsepower					HMCP
	200V	208V	230V	380V	460V	
1	—	—	—	3/4	3/4	3
	3/4	1	1	2	2	7
	2	2	2	3	5	15
	5	5	5	10	10	30
2	7-1/2	7-1/2	7-1/2	—	—	50
	—	—	—	—	—	30
	10	10	10	15	20	50
3	—	—	15	25	25	70
	—	—	—	—	—	50
4	15	20	20	30	40	100
	25	25	30	50	50	150
5	40	40	40	60	100	150
	—	—	50	75	—	250
6	50	50	60	—	125	250
	75	75	75	150	200	400
	—	—	100	—	—	600

Circuit Breaker Application Chart

Frame	Frame Rating (Amperes)	Interrupting Rating (kA Symmetrical Amperes)	
		208/240V	480V
Standard Rating Molded Case Circuit Breakers			
E125H	125	65	65
J250H	250	65	65
HKD	400	65	65
HLD	600	65	65
NGH	1200	65	65
RGH	2500	65	65
High Interrupting Rating Molded Case Circuit Breakers			
FDC	150	100	100
JDC	250	100	100
KDC	400	100	100
LDC	600	100	100
NGC	1200	100	100
RGC	2500	100	100
Magnum DS Air Circuit Breakers			
MDS-608	800	65	65
MDS-C08	800	100	100
MDS-616	1600	65	65
MDS-C16	1600	100	100
MDS-620	2000	65	65
MDS-C20	2000	100	100
MDS-632	3200	65	65
MDS-C32	3200	100	100

Notes

^① Suitable for use with NEMA Design B and D (high efficiency) motors.

Circuit breakers can be supplied with optional shunt trip.

Product Specifications**Structure**

- NEMA 1, 2, 3R or 12 enclosure
- Copper horizontal bus 600–3200A
- Fully rated copper vertical bus
- Optional isolating barriers between structures
- Insulated labyrinth vertical bus is standard on the **XT** MCC
- Insulated horizontal bus and insulated labyrinth vertical bus is standard on **XT** FlashGard MCCs
- Heavy-duty spring operated quarter-turn door latches
- 65 kA and 100 kA bus bracing

Units

- **XT** and **XT** FlashGard motor starters:
 - NEMA size 1–5
 - NEMA rated **XT** contactor
 - C440 overload relay
 - Single-phase protection
 - Class 10 and 20 protection
- HMCP with combination starter ratings of 65 kAIC and 100 kAIC at 480V
- Plug-in units up to 400A
- Handle mechanism with positive trip indication
- Side-mounted positive latch terminal block
- Motor load terminal block is standard on both the **XT** and **XT** FlashGard MCCs
- 6.00-inch (1X) size 1 and 2 FVNR starters, 12.00-inch (2X) size 3 and 4 FVNR starters, add 1X for FVR versions
- Optional communications without increasing unit footprint
- Soft Starters:
 - S811+ (20–700 hp)
- Adjustable Frequency Drives:
 - MVX (1–10 hp)
 - SVX9000 (2–600 hp)
- K-Switch visible blade disconnect:
 - 30–800A
- Surge protection:
 - SPD Series (100–400 kA)
- Energy monitoring:
 - IQ 100 (amperes, volts)
 - IQ 250 (adds, Hz, watts, PF)
 - IQ 260 (adds THD, Contact I/O)
 - IQ Analyzer (adds trending, waveform display)
 - Power Xpert (adds high-end metering, power quality analysis, open communications and Web server gateway)

XT and Freedom XT FlashGard



Contents

Description

XT and XT FlashGard Check Sheets

XT and XT FlashGard Motor Control Center Takeoff Check Sheet

Customer/Job Name	Neg No.
MCC Model	
XT	XT FlashGard
Service 60 Hz	208V/230V/480V
Voltage 50 Hz	380V/415V
Three-wire /four-wire	
Structure Configuration	
16-inch front mount	21-inch front mount
21-inch front and rear mount	
42-inch front mount back-to-back	
32-inch front mount back-to-back	
NEMA 1 /2DP/12/3RNI/3R aisle/3R tunnel	
Enclosure Modifications	
Space heaters (150W) 120V/240V	
Channel sills	CBC/IBC seismic qualified
Thermostat	Split proof
Bottom plates	Split rear cover
Corner structure	Vertical section barrier
8-inch vertical wireway	Special paint color (adder)
	ABS Certification
Handle extensions ("two meter rule")	
Top hat (certain sections)	12-inch/18-inch/24-inch
Top hat (all sections)	12-inch/18-inch/24-inch

Bus Rating and Options	
Horizontal bus	600 /800/1200/1600
21-inch deep structure only	2000/2500/3200
Bus plating	Silver (AG)/ tin (SN)
Bus temp rise	50°C/ 65°C
Insulated horizontal bus	
Vertical bus	600/800/1200
Ground bus	300/600/800
Location	Top /bottom
Vertical ground bus	Lugs: incoming /each end
Neutral bus (4W only)	Half/full/ lug pad
Bus bracing	42K/ 65K /100K
Vertical bus barrier	STD labyrinth with shutter
Incoming Line Metering	
IQ 130/140/150	
IQ 250/260	
IQ DP-4130	
IQ Analyzer	
Power Xpert 2250/2260/2270	
Power Xpert 4000/6000/8000	
Incoming Protection	
SPD Series surge protective device	
Incoming Line MLO/Breaker/Switch	
Cable—top/bottom/bus duct	
Main trip: LS/LSI/LSG/LSIG/ALSI, ALSIG/ other	
Crimp lugs	Screw type lugs
Main tie main (MTM)	Auto throw over
Kirk key	Service entrance (SUSE)

**XT and XT FlashGard Motor Control Center
 Takeoff Check Sheet, continued**

Breaker Options	
Aux. contacts (1NO 1NC) (2NO 2NC)	_____
LS/LSI/LSIG/LSG trip units	_____
Under voltage release	Shunt trip _____
Panelboards	
14/18/26/30/32/42 count	1-pole/2-pole/3-pole _____
Starter Disconnect Type	
HMCP/fusible _____	
NEMA wiring class	
1A/1B/2B/1C/2C/1S/2S	_____
HMCP/TM. Bkr./fusible _____	
If any type "C" choose MTB location: Master terminal blocks (MTBs) top/bottom/relay structure _____	
Terminal Blocks	
Side latch pull apart (Std) (2x6-point)	_____
Spare points = _____% (call DSE)	Front utility (call DSE) _____
Nameplates: Black with White Letters / White with Black Letters	
Starter OL Types	
Solid-state	_____
Solid-state with ground fault	_____

Control Power Source	
Single 24 Vdc power supply per 3 structure shipping split	_____
Dual redundant 24 Vdc power supplies per 3 structure shipping split	_____
External 24 Vdc power supply	_____
Auxiliary Starter Contacts	
NO 1/2/3/4	NC 1/2/3/4 _____
Communications	
EtherNet/IP	Other protocol via gateway _____
Modbus TCP	_____
S811+ Soft Starters	
Isolation contactor	MOVs _____
Pump control software	Bypass starter _____
VFDs	
EMI/RFI	Line fuses _____
dV/dT filter 600 ft or 1000 ft	3-contactor bypass _____
Harmonic Correction Unit	
50A/100A	_____

3.5

Motor Control Centers

XT and XT FlashGard Check Sheets

3

Component Count Sheet

FVNR Starters		FVR Starters	
Size	Quantity	Size	Quantity
1		1	
2		2	
3		3	
4		4	
5		5	

Feeder Breakers

Single	Quantity
50A	
100A	
150A	
225A	
250A	
400A	
600A	
800A	
1200A	
1600A	
2000A	
2500A	
3200A	

VFDs

HP	Quantity	Type
1.5		CT/VT
2		CT/VT
3		CT/VT
5		CT/VT
7.5		CT/VT
10		CT/VT
20		CT/VT
25		CT/VT
30		CT/VT
40		CT/VT
50		CT/VT
60		CT/VT
75		CT/VT
100		CT/VT
125		CT/VT
150		CT/VT
200		CT/VT
250		CT/VT
300		CT/VT
350		CT/VT
400		CT/VT
450		CT/VT
500		CT/VT
600		CT/VT
700		CT/VT

Two Speed, One Winding		Two Speed, Two Winding	
Size	Quantity	Size	Quantity
1		1	
2		2	
3		3	
4		4	

Fusible Feeders

Single	Quantity
30A	
60A	
100A	
200A	
400A	
600A	
800A	
1200A	

Starter Circuit Protection	Future Space	
	Size	Quantity
HMCP	2X	
Fusible	3X	
	4X	

Relay Panels

Size	Quantity
2X	
3X	
4X	
5X	
6X	
7X	
8X	
9X	
10X	
11X	
12X	

Component Count Sheet, continued

Soft Starters

hp	Quantity	Duty	Cable Exit
20		Std/severe	
40		Std/severe	
60		Std/severe	
75		Std/severe	
125		Std/severe	
200		Std/severe	
300		Std/severe	Top/bottom
350		Std/severe	Top/bottom
450		Std/severe	Top/bottom
500		Std/severe	Top/bottom
600		Std/severe	Top/bottom
700		Std/severe	Top/bottom

Transformers

Single-Phase	Quantity	Three-Phase	Quantity
3 kVA		9 kVA	
5 kVA		15 kVA	
7.5 kVA		25 kVA	
10 kVA		30 kVA	
15 kVA		45 kVA	
20 kVA			
25 kVA			
30 kVA			
45 kVA			

Magnum DS Switchgear



4.1	Magnum DS Metal-Enclosed	
	Cross-Reference	V3-T4-2
	Product Description	V3-T4-2
	Application Description	V3-T4-2
	Features, Benefits and Functions	V3-T4-2
	Options	V3-T4-5
	Standards and Certifications	V3-T4-5
	Product Selection	V3-T4-5
	Technical Data and Specifications	V3-T4-6
4.2	Primary and Secondary Unit Substations	
	Product Description	V3-T4-7
	Application Description	V3-T4-7
	Features, Benefits and Functions	V3-T4-7
	Options	V3-T4-7
	Standards and Certifications	V3-T4-8
	Product Selection	V3-T4-8
	Technical Data and Specifications	V3-T4-8

4.1

Low Voltage Switchgear

Magnum DS Metal-Enclosed

Magnum DS Switchgear with Molded Case Circuit Breaker Feeder Section



4

Contents

<i>Description</i>	<i>Page</i>
Magnum DS Metal-Enclosed	
Features—Bus	V3-T4-3
Features—Wiring	V3-T4-3
Features—Breaker	V3-T4-4
Magnum DS Switchgear—Trip Units	V3-T4-5
Options	V3-T4-5
Standards and Certifications	V3-T4-5
Product Selection	V3-T4-5
Technical Data and Specifications	V3-T4-6

Cross-Reference

Eaton’s Electrical Sector has an organization dedicated to the support of current and vintage switchgear breakers and parts that date as far back as the 1950s. These include the Magnum™ DS, DSII, DS and DB families. For more information, refer to YES Catalog No. CA08105000E or call 1-800-BKR-FAST (257-3278).

Available in NEMA® 3R walk-in and non-walk-in configurations.

Product Description

Eaton’s Magnum DS Switchgear is backed by 50 years of power circuit breaker and switchgear development that have set industry standards for quality, reliability, maintainability and extended operating life.

Magnum DS Switchgear is an assembly of metal enclosures housing power circuit breakers, and normally include control and measuring devices such as relays, instruments, meters and the necessary power bus work and control wiring for AC systems applications up to 600 volts.

Application Description

Switchgear is used in the protection, controlling and monitoring of low voltage distribution systems. Although used as “standalone” distribution assemblies, they are quite often incorporated into secondary unit substations so that the equipment can be located more closely to the point of power usage. Magnum DS Switchgear is ideally suited to applications calling for all types of industrial, commercial and utility users having distribution systems rated 600 volts or below, 200,000 amperes or below bus bracing, and 10,000 amperes or below continuous loads.

Features, Benefits and Functions

Standard Finish—The light gray paint finish (ANSI 61) uses a modern, completely automated and continuously monitored electrostatic powder coating. This continuously monitored system includes spray de-grease and clean, spray rinse, iron phosphate spray coating spray rinse, non-chemical seal, oven drying, electrostatic powder spray paint coating and oven curing.

Integral Base—The rugged formed base greatly increases the rigidity of the structure and reduces the possibility of damage during the installation of the equipment and is suitable for rolling, jacking and handling. A lifting angle is permanently welded into the bus compartment structure for increased strength.

Heavy-Duty Door Hinges—

Each breaker door is mounted with hinge pins. Removal of the door is easily accomplished by just lifting the hinge pin. This allows easy access to the breaker internal compartment for inspection and maintenance.

Rear Cover/Doors—

In Magnum DS Switchgear, standard rear covers with captive hardware are the bolt-on type. They are split into two sections to facilitate handling during removal and installation. Optional rear doors are also available.

Through-the-Door Design—

The following functions may be performed without the need to open the circuit breaker door: levering the breaker between positions, operate manual charging system and view the spring charge status flag, close and open breaker, view and adjust trip unit, and read the breaker rating nameplate.



Through-the-Door Design

Front Accessible—When the door is open or removed, each breaker compartment provides front access to isolated, vertical wireways, primary disconnects, cell current transformers and other breaker compartment accessories for ease of field wiring and troubleshooting field connections.

Four-Position Drawout—

Breakers can be in connected, test, disconnected or removed position. The breaker compartment door can be closed in the connected, test and disconnected positions.

Closing Spring Automatic Discharge—

Mechanical interlocking automatically discharges the closing springs when the breaker is removed from its compartment.



Breaker Cell

Breaker Inspection—

When withdrawn on the rails, breaker is completely accessible for visual inspection; tilting is not necessary. The rails are permanent parts of every breaker compartment.

Interference interlocks are supplied on breakers and in compartments where the compartments are of the same physical size to ensure that an incorrect breaker cannot be inserted.

Features—Bus

Buses and Connections—Vertical and cross bus ratings in Magnum DS Switchgear are based on a UL® and ANSI standard temperature rise of 65°C above a maximum ambient air temperature of 40°C.

Bus Ampacities—

Vertical and cross bus ratings in Magnum DS are 2000, 3200, 4000, 5000 and 6000 amperes. In addition, 8000 and 10,000 amperes continuous cross bus ratings are also available.

Bus Bracing—

Unique vertical bus configuration provides an optional short-circuit withstand rating of 150,000 amperes without the need for preceding current limiting fuses. Standard bracing is 100,000 amperes. The U-shaped bar is the heart of the Magnum DS vertical bus. This configuration provides a much higher mechanical strength. To further demonstrate the strength and rigidity of this bus system, it has been verified through testing to withstand 85,000 amperes short-circuit for a full 60 cycles.

Silver Plating—

Bolted, silver-plated copper main buses are standard. The plating is over the entire length of the bar, not just at the joints. Optional tin-plated copper buses are available.

Bus Joints—

All joints are bolted and secured with Belleville-type spring washers for maximum joint integrity. These washers reduce the potential of joint hardware loosening during the change of joint temperature associated with variations of the loads. As an option, maintenance-free hardware can be provided.

Full Neutral—

For four-wire applications, the neutral bus is rated 100% of main bus rating as standard.

Ground—

A ground bus is furnished for the full length of the switchgear assembly and is fitted with terminals for purchaser's connections.

Glass-Reinforced Polyester Stand-Off Insulation System—

Glass-reinforced polyester has been used on both low and medium voltage switchgear for decades. By combining this industry-proven material with our other insulation materials, a total system providing exceptional mechanical and dielectric withstand strength, as well as high resistance to heat, flame and moisture, is produced. Substantial testing to demonstrate accelerated effects of heating and cooling on the mechanical and dielectric properties of this system prove it to provide superior performance for decades of trouble-free operation.

Features—Wiring

Cable Compartment—

The cable compartment gives ample room for terminating the power cables. Removable top roof sheets allow for easy conduit hub installation. The floor of the cable compartment is open to allow cable entry from underground duct banks. Optional floor plates are available.

Lug Pad—

The lugs are located on the breaker run-backs to accommodate lug orientations at a 45° angle to reduce the bending radius of the cable needed for making the connections, thus reducing installation and maintenance time. Mechanical setscrew type lugs are standard. Optional NEMA two-hole compression lugs are available as an option.

Control Wireway—

An isolated vertical wireway is provided for routing of factory and field wiring in each switchgear section. Breaker secondary terminal blocks are mounted as standard above each circuit breaker. The terminal blocks are rated 30 amperes and will accept bare wire, ring or spade terminals for wire size ranges of #22 to #10. Extruded loops are punched in side sheets of the vertical wireway to allow securing of customer control wiring without the use of adhesive wire anchors.

*Control Wireway*

Control Wire—Standard wire is Type SIS insulated stranded copper, extra flexible No. 14 AWG minimum.

Control Wire Marking—

Each wire is imprinted with ink cured under ultraviolet light for durability and for easy identification by the user. The enhanced solvent resistance and durability of the aerospace-grade UV cure ink has been tested for severe environments. The imprinting is made periodically along the length of the wire, with the ends being imprinted more frequently. The point of origin, wire designation and point of destination are imprinted in the following format: <origin zone/wire name/destination zone>. Each device has a uniquely designated zone. "<" indicates the direction of the wire origination and ">" indicates the direction of the wire destination. As an option, wire marking can be made using sleeve type or heat shrink sleeve type.

*Control Wire Marking***Secondary Terminal Compartment Door—**

The customer's secondary terminal connections are located behind a separate door providing access to these connections without the need to open the breaker compartment door.

Shipping Split Connection—

At each shipping split, the control connections are made with plug-in terminal blocks rated 600 volts, 40 amperes. The terminal blocks interlock mechanically without removing the line or load connections. This method of making the shipping split control connections increases the speed of installation and reduces the potential of incorrect connections.

Features—Breaker

Contacts—The Magnum DS has silver tungsten moving contacts and silver graphite stationary contacts. The contacts provide a long-wearing, low-resistance joint. The contacts are protected from arcing damage even after repeated interruptions by the "heel-toe" action that causes the integral arcing contacts to mate before the main contacts part. The arcing contacts then part last, striking the arc away from the main contacts.

The main contacts are of the butt type and are composed of a multiplicity of fingers to give many points of contact without alignment being critical.

*Magnum DS Breaker Contacts
(Arc Chutes Removed)***Stored-Energy Mechanism—**

A cam-type closing mechanism closes the breaker. It receives its energy from a spring that can be charged by a manual handle on the front of the breaker or by a universal electric motor.

Release of the stored energy is accomplished by manually depressing a button on the front of the breaker or electrically energizing a releasing solenoid.

Arc Chute—There are three basic means of extinguishing an arc: lengthening the arc path; cooling by gas blast or contraction; and deionizing or physically removing the conduction particles from the arc path.

The DE-ION® principle is incorporated in all Magnum DS circuit breakers. This makes possible faster arc extinction for a given contact travel, and ensures positive interruption and minimum contact burning.

Levering Mechanism—

The worm gear levering mechanism is self-contained on the breaker drawout element and engages slots in the breaker compartment. A removable crank is used to lever the breaker between the connected, test and disconnected positions.

Mechanical interlocking is arranged so that levering cannot be accomplished unless the breaker is in the opened position.

Protection During Levering Operation—

When levering the breaker between the connected, test and disconnected positions, the operator is protected from contact with live parts by the breaker door.

*Levering Magnum DS Breaker*

True Two-Step Stored Energy Closing—

This sequence is required to charge and close the breaker.

The breaker closing springs are charged either through the manual-charging handle or by the optional charging motor. The breaker is mechanically interlocked to prevent closing of the breaker until the closing springs are fully charged.

With the closing springs fully charged, the breaker can then be closed by pressing the manual close pushbutton on the breaker, or by the optional spring release coil through a remote electrical signal.

This means that the energy required to open the breaker is always prestored following a closing operation.

“Stored energy” is energy held in waiting, ready to open or close the breaker within five cycles or less. The unique cam and spring design provides necessary energy for a single close-open sequence, as well as the energy for multiple charge-close operations such as this possible sequence: charge-close-recharge-open-close-open.

The closing springs are interlocked with the breaker racking mechanism to ensure that the closing springs are discharged before the breaker can be removed from the compartment.

Manually Operated

Breakers—Manually operated breakers are equipped with a manual charging handle to charge the closing springs. Manual closing and tripping pushbuttons are utilized to operate the breaker. Remote closing and tripping can be accomplished by installing optional electric spring release and shunt trip coils. The breaker closing springs must be charged manually, then remote closing and tripping signals can be sent to the breaker.

Electrically Operated

Breakers—Electrically operated breakers are equipped with a spring charging motor and electrically operated spring release and shunt trip coils. The breaker manual charging handle can be used to charge the closing springs when power is not available to the charging motor.

Provisions for Padlocking—

All breakers include provision for padlocking open to prevent electrical or manual closing. This padlocking can secure the breaker in the connected, test or disconnected position by preventing levering of the breaker.

Ease of Inspection and

Maintenance—Magnum DS breakers are designed for maximum accessibility and the utmost ease of inspection and maintenance.

Magnum DS Switchgear—**Trip Units****Digitrip® RMS Trip Unit—**

The Digitrip RMS trip units feature a dependent curve that is depicted in the nameplate by a blue shaded area of the trip curve. The dependent curve affords better protection flexibility. Additionally, all of the trip units have, as standard, thermal memory, 50/60 Hz operation and thermal self-protection at 90°C.

Digitrip RMS Integral Microprocessor-Based Breaker Overcurrent Trip Systems—

These systems provide maximum reliability with true rms sensing as standard, gives excellent repeatability, and requires minimum maintenance. No external control source is required for its protective functions.

Trip Functions—Magnum DS trip units provide the maximum in flexibility and are available in the following configurations: LSI, LSIG and LSIA (ground fault alarm only). In each case, either the short delay or the instantaneous function (not both) may be defeated. This reduces the need for spare breaker inventories and provides maximum utilization of interchangeable breakers.

Options**Special Designs**

The Magnum DS design allows Eaton to provide special solutions to meet our customer's needs. For example, as shown below, here we embedded molded case circuit breakers into a switchgear lineup for a customer.



Magnum DS Switchgear with Molded Case Circuit Breaker Feeder Section

Refer to TD01901001E for application data.

Standards and Certifications

Magnum DS Switchgear assemblies have undergone an extensive seismic qualification program. The test program utilized ANSI standard C37.81, the Uniform Building Code® (UBC) and the California Building Code (CBC) as a basis for the test program. The assemblies have been tested and qualified to exceed these requirements.

Magnum DS Switchgear conforms to the following standards: CSA®, ANSI C37.20.1, C37.51, and UL Standard 1558, and is built in an ISO® certified facility.

American Bureau of Shipping (ABS) certification is also available.

Contact Eaton for details and part numbers for CSA-approved units.

**Product Selection**

Refer to TD01901001E for application data.

Contact Eaton for configurations, pricing and availability.

4.1

Low Voltage Switchgear

Magnum DS Metal-Enclosed

Technical Data and Specifications

Product Specifications

Refer to Section 16426A of the *Product Specification Guide*.

4

Available Bus Ratings

Cross Bus Ampacity	Bus Bracing kA	Vertical Bus Ampacity
2000	100, 150, 200	2000
3200	100, 150, 200	3200
4000	100, 150, 200	4000
5000	100, 150, 200	5000
6000	100, 150, 200	—
8000	100, 150, 200	—
10,000	100, 150, 200	—

Vertical section bus is sized per main cross bus maximum rating or by ANSI C37.20.1 Section 7.4.13 Table 11 to a maximum of 5000 amperes.

Note: In addition to the available bus bracings shown above, the bus has been tested for short-circuit values of 85,000 amperes for a full 60 cycles.

Ratings of Magnum DS Breakers

Breaker Type	Frame Amperes	Ratings, rms Symmetrical Amperes			Short-Time Rating		
		Interrupting Rating [Ⓢ]			208–240 Volts	480 Volts	600 Volts
		208–240 Volts	480 Volts	600 Volts	208–240 Volts	480 Volts	600 Volts
MDS-408	800	42,000	42,000	42,000	42,000	42,000	42,000
MDS-608	800	65,000	65,000	65,000	65,000	65,000	65,000
MDS-808	800	85,000	85,000	85,000	85,000	85,000	85,000
MDS-C08	800	100,000	100,000	100,000	85,000	85,000	85,000
MDS-616	1600	65,000	65,000	65,000	65,000	65,000	65,000
MDS-816	1600	85,000	85,000	85,000	85,000	85,000	85,000
MDS-C16	1600	100,000	100,000	100,000	85,000	85,000	85,000
MDS-620	2000	65,000	65,000	65,000	65,000	65,000	65,000
MDS-820	2000	85,000	85,000	85,000	85,000	85,000	85,000
MDS-C20	2000	100,000	100,000	100,000	85,000	85,000	85,000
MDS-632	3200	65,000	65,000	65,000	65,000	65,000	65,000
MDS-832	3200	85,000	85,000	85,000	85,000	85,000	85,000
MDS-C32	3200	100,000	100,000	100,000	85,000	85,000	85,000
MDS-840	4000	85,000	85,000	85,000	85,000	85,000	85,000
MDS-C40	4000	100,000	100,000	100,000	100,000	100,000	100,000
MDS-850	5000	85,000	85,000	85,000	85,000	85,000	85,000
MDS-C50	5000	100,000	100,000	100,000	100,000	100,000	100,000
MDS-860	6000	85,000	85,000	85,000	85,000	85,000	85,000
MDS-C60	6000	100,000	100,000	100,000	100,000	100,000	100,000

Note

[Ⓢ] 200 kA available; contact Eaton.

MVS Primary Switch and Low Voltage Metal-Enclosed Switchgear



Contents

Description

	<i>Page</i>
Primary and Secondary Unit Substations	
Standards and Certifications	V3-T4-8
Product Selection	V3-T4-8
Technical Data and Specifications	V3-T4-8

Product Description

Unit Substations

Most switchgear assemblies are configured as unit substations.

A unit substation, as referred to in this publication, is defined as a coordinated assembly consisting of three-phase transformers with high-voltage incoming line sections and an assembly of low voltage distribution sections.

Liquid-Filled Transformers

- Mineral oil
- FR3
- BIOTEMP®
- Silicon

Dry-Type Transformers

- VPI
- VPE
- RESIBLOC®
- Cast coil

Secondary Unit Substations

- Liquid-filled or dry-type transformer
- Transformer kVA 112.5 through 3750
- Low voltage—208, 240, 480 or 600V

Primary Unit Substations

- Liquid-filled or dry-type transformer
- Transformer kVA 500 through 20 MVA
- Low voltage—2400V through 24.5 kV

Unit substations may be indoor or outdoor, with a selection of high voltage incoming sections, a choice of transformer types and an arrangement of switchgear to suit the application.

Eaton's unit substations follow the system concept of locating transformers as close as practicable to areas of load concentration at usage voltages, thus minimizing the lengths of secondary distribution cables and buses. This concept provides several basic advantages, such as:

- Reduced power losses
- Improved voltage regulation
- Improved service continuity
- Reduced likelihood of faults
- Increased flexibility
- Minimized installation expense
- Elimination of the need for vaults due to availability of non-flammable types of transformers
- Efficient space utilization

Application Description

Advantages of Unit Substations

- Complete coordination, both mechanical and electrical
- Extreme flexibility with wide choice of components and ratings to meet exact application requirements
- Optimum safety to operators
- Modern design
- Meets all applicable ANSI, IEEE®, NEMA and UL standards

Features, Benefits and Functions

Refer to TD.49A.01.T.E for primary unit substations and TD.49A.02.T.E for secondary unit substations.

Options

Refer to TD.49A.01.T.E for primary unit substations and TD.49A.02.T.E for secondary unit substations.

4.2

Low Voltage Switchgear

Primary and Secondary Unit Substations

4

Standards and Certifications

Refer to TD.49A.01.T.E for primary unit substations and TD.49A.02.T.E for secondary unit substations.

Contact Eaton for details and part numbers for CSA-approved units.



Product Selection

Unit substations are engineered to order and have multiple configurations. Contact Eaton for configurations, pricing and availability.

Technical Data and Specifications

Refer to TD.49A.01.T.E for primary unit substations and TD.49A.02.T.E for secondary unit substations.

Product Specifications

Refer to Section 16312 of the *Product Specification Guide* for primary unit substations and Section 16311 of the *Product Specification Guide* for secondary unit substations.

Medium Voltage Motor Control Assemblies

Arc Resistant AMPGARD



5.1 AMPGARD Motor Control

Product Description	V3-T5-2
Application Description	V3-T5-2
Features, Benefits and Functions	V3-T5-3
Standards and Certifications	V3-T5-4
Product Selection	V3-T5-5
Technical Data and Specifications	V3-T5-6

AMPGARD Motor Control Assembly with Main Breaker, SC 9000 AFD, RVSS and Two-High FVNR



Product Description

Eaton’s AMPGARD® medium voltage starter family provides flexibility never before available. Rated at 2200–15,000 volts up to 8000 hp, they are the first starters designed as integrated, complete units precisely matched to motor ratings, and engineered to provide component-to-component circuitry and front accessibility of all components and terminals. AMPGARD starters are used in a variety of industrial process applications, such as pulp and paper, petrochemical, HVAC (chillers), where proper control and protection of the motor and system are critical to the user. AMPGARD has been the industry leader in medium voltage motor control for over 60 years in these applications, and our starters have been designed with that experience behind them.

Application Description

AMPGARD starters are equipped with current limiting power fuses to interrupt the short-circuit faults shown below. The contactor and fuses are completely coordinated.

Squirrel Cage Motor Starters:

Starters for squirrel cage motors are available in full or reduced voltage designs in all ratings. Full voltage starters are available one-high or two-high in a factory-assembled structure. Electromechanical reduced voltage starters are available in either reactor or autotransformer type. Both provide closed transition from reduced to full voltage. See table on **Page V3-T5-6** for application data.

Contents

Description

Features, Benefits and Functions	V3-T5-3
Standards and Certifications	V3-T5-4
Product Selection	V3-T5-5
Technical Data and Specifications	V3-T5-6

Page

SC 9000 Adjustable Frequency Drive (AFD)

This newest member of the AMPGARD family was designed for maximum flexibility in the control of medium voltage motors. The SC 9000™ combines innovative technology with the reliable design and construction the industry has come to expect of the AMPGARD products. Rated at 2400 volts up to 2500 hp and 4160 volts up to 4500 hp, the SC 9000 delivers the smallest footprint in the industry. The standard 24-pulse phase shifting isolating transformer and rectifier minimizes any harmonic noise sent back on to the supply.

The SC 9000 is a fully integrated, three-line-in—three-line-out, plug-and-play product that includes highly reliable AMPGARD medium voltage components on the input (isolation switch, power fuses and SL vacuum contactor), isolating transformer, rectifier, inverter and controls. The SC 9000 uses the same keypad and programming software as the

Eaton SVX9000 line of low voltage drives for a reliable, easy-to-use system that does not require time spent in learning new software. In addition, the SC 9000 can interface with many control systems, such as Modbus®, Ethernet, DeviceNet™, CANbus® and PROFIBUS® DP.

In an industry first, the SC 9000 can be placed in a lineup with other AMPGARD and Eaton motor control products on a common bus known as AMPGARD Medium Voltage Integrated Control Gear. Now, all types of motor starters, load break switches, integrated AFDs, AFD synchronous transfer control, AFD bypasses, and main and feeder breakers can be integrated into a single line. The Integrated Control Gear capabilities and reliable design make the SC 9000 the perfect choice for speed control in industries such as petrochemical, water/waste water, utility, HVAC, pulp and paper, and many more.

Reduced Voltage Solid-State Starters:

Offered as an alternative to traditional reactor or auto-transformer type reduced voltage starter, the AMPGARD RVSS allows the user to fine-tune starting parameters to meet a wide variety of unique load conditions. The onboard user-friendly microprocessor provides the ability to select the proper combination of initial current, maximum current and ramp time, resulting in smooth, stepless load acceleration while minimizing mechanical shock to system components.

The AMPGARD RVSS is available as a standalone starter or can be incorporated into a lineup with other AMPGARD starters. Adding to an existing AMPGARD installation is easy via a simple splice kit. Starters are available in 400 ampere and 720 ampere frame sizes.

Arc-Resistant AMPGARD:

When specified, AMPGARD is available in special arc-resistant construction. Two ratings are available: 30 kA and 50 kA. Both designs have been tested and verified to meet the requirements of IEEE® C37.20.7 for Type 2B construction. Type 2B construction is defined as arc-resistant at front, back and sides of the enclosure with the low voltage compartment door open. All types of 400 ampere and 800 ampere starters, as well as 24-inch wide incoming cable sections are available in arc-resistant construction. Main Breaker AMPGARD, SC 9000 AFD, LBS Load Break Switches are not available in arc-resistant construction. Consult Eaton for more details.

Main Breaker AMPGARD (MBA):

The MBA is the industry's first truly integrated medium voltage metal-enclosed main breaker and starter assembly combination.

The MBA comprises a metal-enclosed drawout vacuum circuit breaker section that is integrally connected via main bus to the balance of the AMPGARD starter assembly it protects.

The main bus configuration is in the same top-mounted location as on all AMPGARD assemblies, allowing for ease of installation with adjacent sections and addition for future sections.

Front aligned, rear aligned, or front and rear aligned with back-to-back starters are available.

The main breaker is the industry-leading Type VCP-W drawout vacuum circuit breaker, which provides the performance our customers expect.

Lead-time is dramatically reduced, typically 50% less than the industry norm. Our single-source approach has cut delivery time from months to weeks. The extended waiting period between order placement and delivery has been eliminated.

Other Motor Starters:

Starters for wound rotor and multispeed motors are available. However, each application must be reviewed for proper motor protection and operation. Refer to the factory for pricing and equipment details.

Features, Benefits and Functions

Personnel Safety: A positive mechanical isolating switch with visible disconnect completely grounds and isolates the starter from the line connectors with a mechanically driven isolating shutter, leaving no exposed high voltage. Additional safety features include:

- Isolated cable entry for added safety. The starters and cables are completely isolated from each other by steel barriers

- All new low voltage wireway. Low voltage wire is isolated from the medium voltage compartment, and customer terminal blocks are accessible through the low voltage control panel
- Easily accessible low voltage panel completely isolated from the medium voltage compartment that offers generous device mounting space
- Standard viewing window for visual verification of isolation switch operation
- Optional remote operator for isolation switch allows user to open and close switch while remaining outside the equipment flash boundary

Ease of Installation: Current limiting fuses, contactor assembly and isolating switch assembly are easily removed from the enclosure; line and load terminals are completely accessible from the front. Standard structures are 36.00 W x 92.00 H x 30.00 in D (914.4 W x 2336.8 H x 762.0 mm D) including a 12.00 in (304.8 mm) top-mounted main bus compartment. The main bus compartment is top, side and front accessible, making maintenance and lineup extensions easy.

Ease of Maintenance:

All components are front accessible, facilitating routine inspection or parts replacement. Isolation switch life is 10,000 operations.

Vacuum Contactor:

The Type SL vacuum contactors were designed and engineered specifically for use in AMPGARD starters. They are self-supporting, compact, bolt-in or stab-in three-pole contactors. The contactors utilize a solid-state control board, allowing the user maximum flexibility to change control voltages and dropout times in the field, simply by adjusting DIP switch settings. To permit application matching of the starter to the motor rating, contactors are available for

2200–7200 volts at ratings of 400 and 800 amperes, and 15 kV at 250 amperes.

The 400 ampere contactor interrupting rating is the highest in the industry at 8500 amperes, allowing for higher levels of coordination with power fuses. The 800 ampere contactor has an interrupting rating of 12,500 amperes, also the highest in the industry.

Note: For full starter/contacter horsepower ratings and other technical data (including power fuse coordination), refer to Tab 13, Medium Voltage Power Contactors.

Motor Protective Relay:

When a motor protective relay is required, the AMPGARD starters are provided with the MP-3000 or MP-4000 microprocessor-based motor protective relay as standard. This package offers benefits like a 20-cycle voltage sag ride-through, UL 1053 certification for ground fault sensing that is internal to the relay, arm/disarm capability, a drawout case option, Intel-I-Trip overload protection for custom curve setting to precisely match your motor's requirements, and optional PowerNet™ or Modbus communications capability.

15 kV Starter: A 15 kV rated AMPGARD starter is available with the same features and capabilities as described for the 7.2 kV rated starter. The starter is supplied with a 250 ampere vacuum contactor and three power fuses (maximum 250E) for motors rated to 5000 horsepower. These starters may be supplied with the Eaton InsulGard™ relay for partial discharge detection.

5.1

Medium Voltage Motor Control Assemblies

AMPGARD Motor Control

5

Low Voltage and High Voltage Compartments

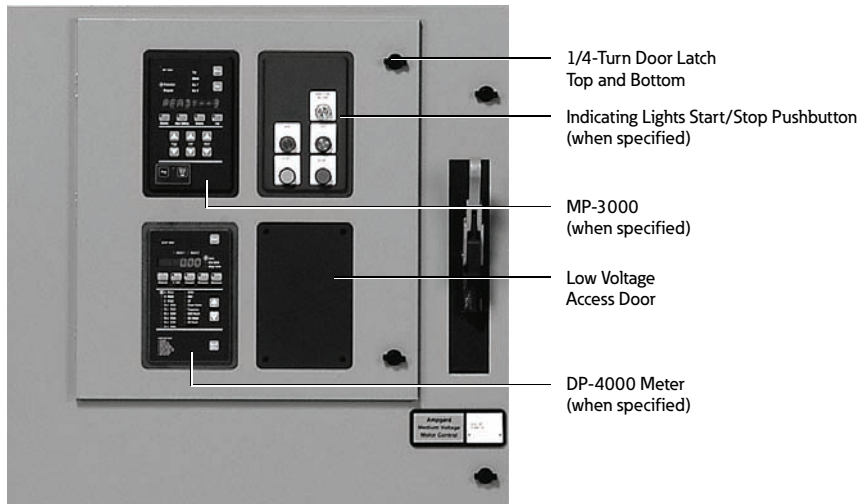

Isolated Low Voltage Control Panel

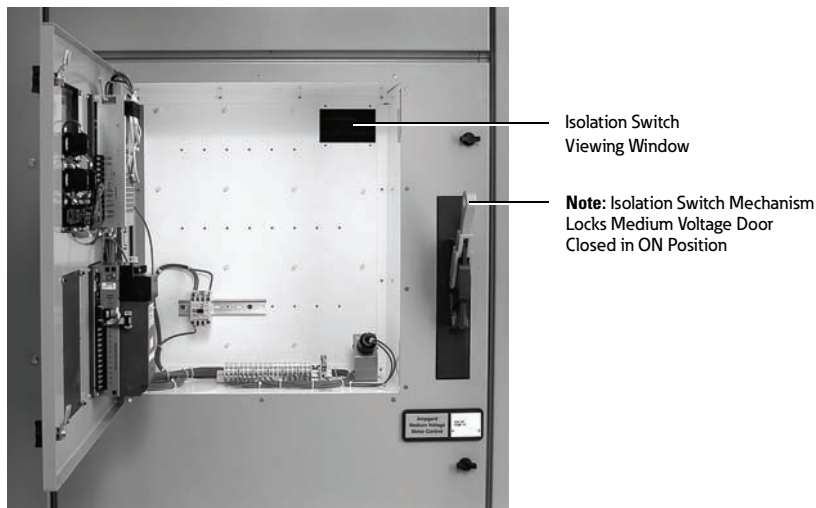

Optional Stab-In Contactor, Bolted Main Fuses and Optional Blown Fuse Indicator

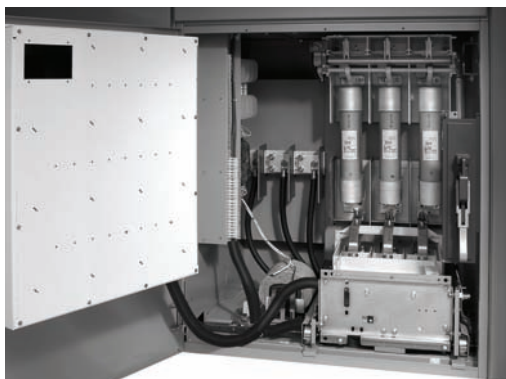

Standards and Certifications

UL and CSA Certification

AMPGARD starters are designed, assembled and tested to meet all applicable standards. AMPGARD meets ANSI, NEMA® and IEC standards, and is UL, CSA, cUL® and KEMA third-party certified. The major components, i.e., contactor, isolating switch, fuses, MP-3000, MP-4000, IQ DP-4000 and IQ Analyzer, are UL recognized.

UL or CSA labeling of a specific starter requires review to ensure that all requested modifications and auxiliary devices meet the appropriate standards. Refer to factory when specified.

Contact Eaton for details and part numbers for CSA-approved units.



Seismic Certification

AMPGARD starters are seismically tested and seismically qualified, and exceed requirements of both the International Building Code (IBC) and California Building Code Title 24.

Reference Information

- AMPGARD Brochure
BR02003002E
- AMPGARD RVSS Brochure
BR02003001E
- Technical Data
TD02003001E
- Renewal Parts
RP48J.01.T.E
- AMPGARD Main Breaker
PA48D01SE
- 15 kV AMPGARD
Technical Data
TD02003002E
- Remote Operator
PA02003002E
- Arc-Resistant AMPGARD
SA02003003E
- 720A RVSS
PA02000001E

Product Selection

AMPGARD RVSS



AMPGARD RVSS

Description	Catalog Number
400 ampere RVSS	SP10B4B
720 ampere RVSS	SP10B8S

Main Breaker AMPGARD



Main Breaker AMPGARD

Description	Catalog Number
1200A, 250 MVA Main Breaker	BLR12
2000A, 350 MVA Main Breaker	BLR23
3000A, 350 MVA Main Breaker	BLR33

15 kV Starter with InsulGard



15 kV Starter

Description	Catalog Number
13.8 kV FVNR Starter	S210B2SBB
13.8 kV Autotransformer Starter	S610B2SBB

Technical Data and Specifications

Main Breaker AMPGARD

Description	Ratings		
	Amperes	Volts	Horsepower
Main breaker	1200, 2000 and 3000	2200 to 7200	—
Starters	400 and 800	2200 to 7200	Up to 8000
Starters	250	10,000–15,000	Up to 5000

5

Starting Characteristics

Starter Type	% Motor Voltage	% Motor Current	% Line Current	% Torque
Reactor Reduced Voltage				
80% tap	80	80	80	64
65% tap ①	65	65	65	42
50% tap	50	50	50	25
Autotransformer Reduced Voltage				
80% tap	80	80	67	64
65% tap ①	65	65	45	42
50% tap	50	50	28	25

Interrupting Capacity—kVA

Starter Maximum Horsepower	NEMA Class E2		
	2300 Volt	4600 Volt	6600 Volt
3000	200,000	—	—
5000	1,190,000	—	—
5500	—	400,000	—
8000	—	—	570,000

Note

① Factory set on 65% tap.

Medium Voltage Metal-Enclosed Switches

Outdoor Medium Voltage Switch



6.1	Medium Voltage Switch—MVS	
	Product Description	V3-T6-2
	Application Description	V3-T6-2
	Features, Benefits and Functions	V3-T6-2
	Standards and Certifications	V3-T6-3
	Reference Information	V3-T6-3
	Product Selection	V3-T6-3
	Technical Data and Specifications	V3-T6-3
6.2	Medium Voltage Switch and Breaker—MSB	
	Product Description	V3-T6-4
	Application Description	V3-T6-4
	Features, Benefits and Functions	V3-T6-4
	Standards and Certifications	V3-T6-5
	Reference Information	V3-T6-5
	Product Selection	V3-T6-5
	Technical Data and Specifications	V3-T6-5
6.3	Metal-Enclosed Breaker—MEB	
	Product Description	V3-T6-6
	Application Description	V3-T6-6
	Features, Benefits and Functions	V3-T6-6
	Standards and Certifications	V3-T6-7
	Reference Information	V3-T6-7
	Product Selection	V3-T6-7
	Technical Data and Specifications	V3-T6-7
6.4	Unitized Power Centers—UPC	
	Product Description	V3-T6-8
	Features, Benefits and Functions	V3-T6-8
	Standards and Certifications	V3-T6-8
	Reference Information	V3-T6-8
	Product Selection	V3-T6-8
	Technical Data and Specifications	V3-T6-9
6.5	OEM Medium Voltage Switch Components—MVS-C	
	Product Description	V3-T6-10
	Application Description	V3-T6-10
	Features, Benefits and Functions	V3-T6-10
	Standards and Certifications	V3-T6-11
	Reference Information	V3-T6-11
	Product Selection	V3-T6-11
	Technical Data and Specifications	V3-T6-11

Outdoor Medium Voltage Switch—MVS Cable Connection to Liquid-Filled Transformer



Product Description

Eaton's MVS load interrupter switchgear is a metal-enclosed assembly consisting of a switch, bus and fuses.

MVS switchgear is available in one or more vertical section assemblies. The three-pole switch will interrupt its rated load current with its quick-make, quick-break mechanism. Optional fuses ensure short-circuit protection at all times.

Application Description

MVS switchgear provides safe, reliable switching and fault protection for medium voltage circuits where high duty cycle operation is not needed.

- Single switch and transformer primary
- Duplex switch
- Selector switch
- Automatic transfer control

Contents

Description

	<i>Page</i>
Medium Voltage Switch—MVS	
Standards and Certifications	V3-T6-3
Reference Information	V3-T6-3
Product Selection	V3-T6-3
Technical Data and Specifications	V3-T6-3



Features, Benefits and Functions

Quick-make, quick-break mechanism: A reliable heavy-duty coil spring mechanism drives the switch blades at high speed into either the open or the closed position. The speed of operation is independent of the person operating the switch.

Direct drive mechanism: A metal-to-metal direct drive mechanism eliminates chains or cables that may break or need adjusting.

DE-ION® arc interruption: DE-ION arc chambers and spring-loaded auxiliary blades ensure fast load current interruption and eliminate arcing damage to the main contacts.

Positive switch position indication: Red and green multilingual (English/Spanish/French) labels located directly on the switch operating mechanism give visual indication of switch position.

Interlocked for safety: Mechanical interlocks prevent closing the switch when the compartment door is open, or the opening of the door when the switch is closed.

Safety under fault conditions: The switch, depending upon the rated voltage, is available with three or four fault-closing operations with ratings up to 61,000 amperes rms asymmetrical, exceeding the industry standards one time operation.

Safety barrier: A hinged solid metal barrier with a perforated metal viewing area shields the disconnect switch when the compartment door is opened.

Short-circuit protection: A full range of Eaton fusing options is available for short-circuit protection.

Eaton's SF₆-free switchgear: Eaton medium voltage switchgear use vacuum switches combined with solid insulation material. This environmentally-friendly technology avoids the use of SF₆ as an insulation gas.

Indoor Medium Voltage Switch—MVS Bus Connection to Dry-Type Transformer

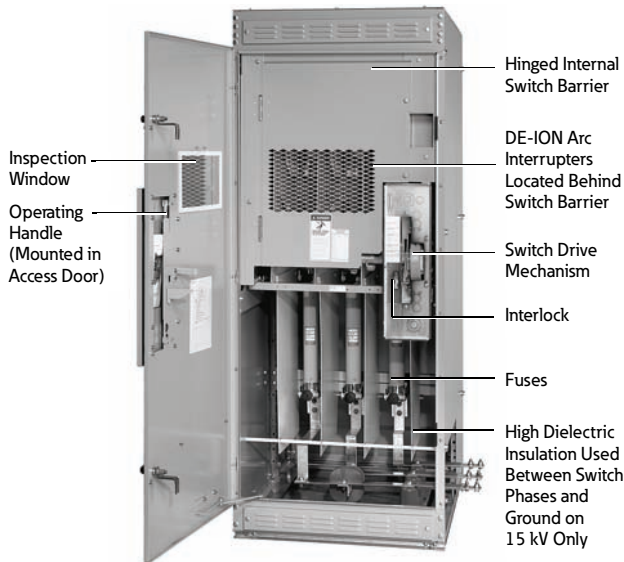

Standards and Certifications

MVS switchgear meets or exceeds IEEE® C37.20.3 as it applies to metal-enclosed switchgear.

Either Underwriters Laboratories® (UL) or Canadian Standards Association® (CSA) listing is available for MVS switchgear in many configurations, with a number of options.

MVS switchgear is available seismically qualified to meet the requirements of the Uniform Building Code® (UBC), California Title 24 and BOCA® requirements in many configurations with a number of options.



Reference Information

See *Consulting Application Guide* for detailed list of ratings and options. For renewal parts, see CA08105001E.

Product Selection

Contact Eaton for pricing.

Technical Data and Specifications

- Rated maximum voltage classes of 5, 15, 27 and 38 kV
- Rated impulse levels, kV BIL: 60, 95, 125, 150
- Continuous and load-break ratings: 600 amperes available at all voltage classes; 1200 amperes available at 5 and 15 kV
- Designs available in indoor and outdoor non-walk-in configurations
- Manual or motor operated

Indoor Medium Voltage Switch and Fixed Breaker—MSB



Product Description

Eaton’s MSB switchgear is an integrated assembly of a visible load-break disconnect switch, fixed-mounted vacuum circuit breaker, and control devices that are integrated electrically and mechanically for circuit protection. All major components are manufactured by Eaton, establishing one source of responsibility for the equipment and ensuring high standards in quality, coordination, reliability and service. MSB switchgear would typically be used where both cost and protection are important design parameters.

Application Description

Applications include ground fault protection, primary and/or secondary switching, and protection on unit substations, automatic transfer switching at medium voltage levels, capacitor switching, high duty cycle and tight system coordination protection.

MSB switchgear can also be an economic benefit in single-ended substations because it may allow the customer to eliminate the secondary main protection and switching device.

- Low resistance ground schemes
- Single-ended substation designs
- Overcurrent protection

Contents

Description

	<i>Page</i>
Medium Voltage Switch and Breaker—MSB	
Standards and Certifications	V3-T6-5
Reference Information	V3-T6-5
Product Selection	V3-T6-5
Technical Data and Specifications	V3-T6-5



Features, Benefits and Functions

- Visible isolation
- Fully rated fixed vacuum circuit breaker
- Electrical operation
- No fuses
- Improved coordination capability
- Improved transformer protection
- Ground fault protection
- Capacitor switching
- High switching duty cycle
- Integral overcurrent protection

Eaton's SF₆-free

switchgear: Eaton medium voltage switchgear use vacuum switches combined with solid insulation material. This environmentally-friendly technology avoids the use of SF₆ as an insulation gas.

Standards and Certifications

MSB switchgear meets or exceeds IEEE C37.20.3 as it applies to metal-enclosed switchgear.

CSA listing is available for MSB switchgear in many configurations with a number of options.

MSB switchgear is available seismically qualified to meet the requirements of the Uniform Building Code, California Title 24 and BOCA requirements in many configurations with a number of options.



Reference Information

See *Consulting Application Guide* for detailed list of ratings and options. For renewal parts, see CA08105001E.

Product Selection

Contact Eaton for pricing.

Technical Data and Specifications

- Rated maximum voltages of 4.76–15 kV
- Continuous current ratings up to 1200 amperes
- 25 and 40 kA rms symmetrical short-circuit interrupting capacity
- Designs available in indoor and outdoor non-walk-in configurations
- Single vertical section and transformer primary configurations
- Lineups consisting of MSB and MVS vertical sections

**Indoor Metal-Enclosed Drawout Vacuum Breaker—MEB
Used as Main for Two Fused Switches**



6

Product Description

Eaton’s MEB switchgear is a metal-enclosed assembly of single high drawout VCP-W vacuum circuit breakers and control devices that are integrated electrically for circuit protection. (For drawout vacuum breaker metal-clad switchgear, type VacClad-W, see **Volume 3, Tab 7**) All major components are manufactured by Eaton, establishing one source of responsibility for the equipment and ensuring high standards in quality, coordination, reliability and service.

Application Description

MEB can be applied as the primary main device and integrated with fused feeder switches in a lineup of fused MVS switchgear.

Applications include ground fault protection, primary and/or secondary switching, and protection on unit substations, automatic transfer switching at medium voltage levels, capacitor switching, high duty cycle and tight system coordination protection.

MEB switchgear can also be an economic benefit in single-ended substations because it may allow the customer to eliminate the secondary main protection and switching device.

- Low resistance ground schemes
- Single-ended substation designs
- Overcurrent protection

Contents

Description

<i>Description</i>	<i>Page</i>
Metal-Enclosed Breaker—MEB	
Standards and Certifications	V3-T6-7
Reference Information	V3-T6-7
Product Selection	V3-T6-7
Technical Data and Specifications	V3-T6-7

Features, Benefits and Functions

- Fully rated drawout vacuum circuit breaker
- Electrical operation
- Improved coordination capability
- Improved transformer protection
- Ground fault protection
- Capacitor switching
- High switching duty cycle
- Integral overcurrent protection

Standards and Certifications

MEB switchgear meets or exceeds IEEE C37.20.3 as it applies to metal-enclosed switchgear.

CSA listing is available for MEB switchgear in many configurations with a number of options.

MEB switchgear is available seismically qualified to meet the requirements of the Uniform Building Code, California Title 24 and BOCA requirements in many configurations with a number of options.



Reference Information

See *Consulting Application Guide* for detailed list of ratings and options. For renewal parts, see CA08105001E.

Product Selection

Contact Eaton for pricing.

Technical Data and Specifications

- Rated maximum voltages of 4.76 and 15 kV
- Continuous current rating of 1200 or 2000 amperes
- Short-circuit current ratings up to 38 kA rms symmetrical
- Designs available in indoor and outdoor non-walk-in configurations
- Single vertical section and transformer primary configurations
- Lineups consisting of MEB vertical sections and MVS vertical sections

Indoor Unitized Power Centers



Bottom Cable Entry and Top Cable Entry

6

Contents

Description

Unitized Power Centers—UPC

Technical Data and Specifications

Page

V3-T6-9

Product Description

Eaton’s Unitized Power Centers combine an MVS primary disconnect switch, a ventilated dry-type transformer and Pow-R-Line 4 secondary distribution devices in a compact, factory-assembled integral unit. These self-contained units provide maximum kVA in minimum space, and their unitized construction simplifies installation.

Other advantages include:

- Front accessibility
- Against-the-wall mounting
- Dimensions consistent with standard doorways
- Liberal space for primary and secondary cables
- Molded case circuit breaker or fusible switch secondary distribution

Features, Benefits and Functions

The primary disconnect switch is a manually operated, two-position, quick-make, quick-break type MVS. Distribution class surge arresters protect the transformer from surge voltages, and current limiting fuses protect against fault currents. Insulated cable passes through a steel barrier to connect the switch to the transformer.

The power transformer is of a ventilated, dry-type, core-form construction. Standard Class 220°C insulation allows normal operation at 150°C temperature rise above a 30°C nominal ambient and a 40°C peak ambient.

The secondary distribution section consists of group mounted Series C® molded case circuit breakers or FDP-W fusible switches separated from the transformer by steel barriers. Additional vertical sections may be added for additional low voltage distribution.

Standards and Certifications

Power transformer core and coil assemblies meet all applicable IEEE/ANSI/NEMA® standards.

Reference Information

See *Consulting Application Guide* for detailed list of ratings and options.

Product Selection

Contact Eaton for pricing.

Technical Data and Specifications

- Indoor enclosure only
- Maximum primary voltages:
 - 3 kV through 15 kV
 - Three-phase, 60 Hz, delta primary
- Primary BIL:
 - Voltages not exceeding 2.5 kV maximum—20 kV BIL
 - Voltages above 2.5 kV up to 7.2 kV maximum—30 kV BIL
 - Voltages above 7.2 kV up to 15 kV maximum—60 kV BIL
- Transformer:
 - 12.5–1000 kVA
 - Winding material, copper type, ventilated dry
- Insulation:
 - Class H 220°C rise (standard)
 - 150°C, 115°C and 80°C rise available
 - Fan cooling available to increase kVA rating by 33¹/₃%
 - Taps: ±(2) 2.5% FCAN and FCBN
- Secondary voltages:
 - 208Y/120 volts—four-wire
 - 240 volts—three-wire
 - 480Y/277 volts—four-wire
 - 575 volts—four-wire
- Secondary BIL: 10 kV BIL

OEM Fusible Switches

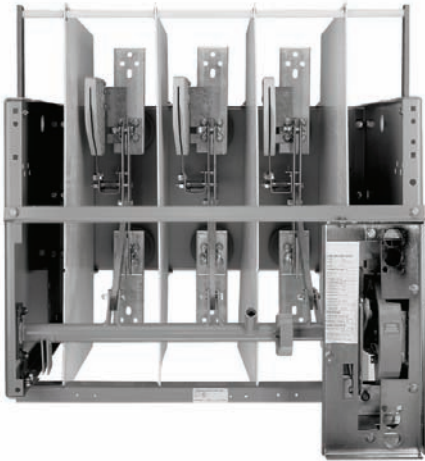

MVS-C Switch

Product Description

MVS-C switches are open frame switches that must be mounted in a suitable enclosure for the OEM market. Eaton's MVS-C load interrupter switches are available in many ratings. When properly applied, they will provide safe, low-cost switching where occasional or infrequent disconnecting means is desired. The three-pole switch, with its quick-make, quick-break mechanism, will interrupt its rated load current.

Application Description

MVS-C switches can be applied in suitable enclosures for many switching duties whether manual or automatic operation is specified:

- Transformer primary switching
- Transformer secondary switching
- Power distribution switching

Contents

Description

OEM Medium Voltage Switch Components—MVS-C

	<i>Page</i>
Standards and Certifications	V3-T6-11
Reference Information	V3-T6-11
Product Selection	V3-T6-11
Technical Data and Specifications	V3-T6-11

Features, Benefits and Functions

Plug & Play™: The switch and operating mechanism install as a single entity. No handle and chains or cables to mount and adjust. Improves productivity in assembly reducing overall cost.

Quick-make, quick-break mechanism: A reliable heavy-duty coil spring mechanism drives the switch blades at high speed into either the open or the closed position.

DE-ION arc interruption: DE-ION arc chambers and spring-loaded auxiliary blades ensure safe, fast load current interruption and eliminate arcing damage to the main contacts.

Positive switch position indication: Red and Green multilingual (English/Spanish/French) labels located directly on the switch operating mechanism give visual indication of switch position.

Interlocked for safety: When properly installed to utilize the built-in design feature, mechanical interlocks prevent closing the switch when the enclosure door is open, or opening the door when the switch is closed. As an alternate interlock method, key interlock provisions are included.

Safety under fault conditions: The switch, depending upon the rated voltage, is available with three or four fault-closing operations with ratings up to 61,000 amperes rms asymmetrical, exceeding the industry standards one-time operation.

Fuse mountings: Complete three-phase fuse mounting assemblies or fuse live parts are available that are fully compatible with MVS-C switches. The fuse mountings are intended for use with Eaton's fuses.



MVS-C Fuse Mounting

Direct drive mechanism: A metal-to-metal direct drive mechanism eliminates chains or cables that need adjusting or break.

Standards and Certifications

- MVS-C switches meet or exceed ANSI C37.22 ratings
- UL and CSA recognized component listing services are available for 5 and 15 kV manual and motor operated MVS-C switches



Reference Information

For renewal parts, see CA08105001E.

Product Selection

Contact Eaton for pricing.

Technical Data and Specifications

- Rated maximum voltage classes of 5, 15, 27 and 38 kV
- Rated impulse levels, kV BIL: 60, 95, 125, 150
- Continuous and load-break ratings: 600 amperes available at all voltage classes; 1200 amperes available at 5 and 15 kV
- Rated momentary and fault close currents, 40 and 61 kA rms asymmetrical; 40 kA available at all voltage classes; 61 kA available at 5, 15 and 27 kV
- Manual, motor or shunt-trip operated

Indoor Type VCP-W Metal-Clad Switchgear Assembly (5/15 kV shown)



7.1	Introduction	
	Product Selection Guide	V3-T7-2
7.2	Metal-Clad Vacuum Switchgear	
	Product Overview	
	Product Description	V3-T7-4
	Application Description	V3-T7-4
	Features, Benefits and Functions	V3-T7-5
	Options and Accessories	V3-T7-6
	Technical Data and Specifications	V3-T7-6
	26-Inch Wide, 5 kV, 250 MVA, 1200A Switchgear	
	Product Description	V3-T7-7
	Application Description	V3-T7-7
	Features, Benefits and Functions	V3-T7-7
	Standards and Certifications	V3-T7-7
	38 kV Metal-Clad Switchgear	
	Product Description	V3-T7-8
	Application Description	V3-T7-8
	Features, Benefits and Functions	V3-T7-8
	Standards and Certifications	V3-T7-8
	Technical Data and Specifications	V3-T7-9
7.3	High Resistance Grounding System	
	Product Description	V3-T7-18
	Application Description	V3-T7-18
	Features, Benefits and Functions	V3-T7-21
	Standards and Certifications	V3-T7-21
	Catalog Number Selection	V3-T7-22
	Technical Data and Specifications	V3-T7-23
	Dimensions	V3-T7-26



Learn
Online

Indoor Type VCP-W Metal-Clad Switchgear Assembly (5/15 kV shown)



7

Contents

Description

Product Selection Guide

Product Selection Guide

Product Offering Chart—Metal-Enclosed ^①

Description	MVS	MEB	MSB	UPC	Mini-MVS
Voltage	5, 15, 27, 38 kV	5, 15 kV	5, 15 kV	5, 15 kV	5 kV only
Operation duty cycle	Low	High	High	Low	Low
Enclosure	Indoor, outdoor aisleless	Indoor, outdoor aisleless	Indoor, outdoor aisleless	Indoor only	Indoor, outdoor aisleless
Listed	UL [®] , CSA [®]	—	—	—	UL, CSA
Assembly standards	ANSI/IEEE [®] , C37.30.3, C37.20.4, C37.22, C37.57, C37.58, CSA 22.2 #31 ^②	ANSI/IEEE, C37.30.3, C37.20.4, C37.22, C37.57, C37.58, CSA 22.2 #31	ANSI/IEEE, C37.30.3, C37.20.4, C37.22, C37.57, C37.58, CSA 22.2 #31	—	ANSI/IEEE, C37.30.3, C37.20.4, C37.22, C37.57, C37.58, CSA 22.2 #31 ^②
Circuit breaker type	N/A	VCP-W	VCP-TR (5, 15 kV), VCP-W 27 kV	N/A	N/A
Circuit breaker mounted	N/A	Drawout	Fixed	N/A	N/A
Seismically rated Zone 4 to California Building Code Title 24	Yes	Yes	Yes	Yes	Yes
BIL ratings	60 kV (5 kV) 95 kV (15 kV) 125 kV (27 kV) 150 kV (38 kV)	60 kV (5 kV) 95 kV (15 kV)	60 kV (5 kV) 95 kV (15 kV) 125 kV (27 kV)	60 kV (5 kV) 95 kV (15 kV)	60 kV (5 kV)
Main bus ratings	800, 1200A (5/15/27/38 kV)	800, 1200A (5/15 kV)	800, 1200A (5/15/27 kV)	N/A	N/A, cable in, cable out application
Breaker ratings	N/A	1200A (5/15 kV)	600, 800, 1200A (5/15/27 kV)	N/A	N/A
Overcurrent protective device	Yes (fused)	Yes	Yes	Yes (fused)	Yes (fused)
Short-circuit interrupting capacity	Per fuse IC	29, 41, 63 kA (5 kV) 18, 28, 37, 63 kA (15 kV)	16, 20, 25, 40 kA (5/15 kV) 25 kA (27 kV)	Per fuse IC	Per fuse IC
Conduit entry	Top or bottom	Top or bottom	Top or bottom	Top or bottom	Top or bottom

Notes

^① Additional products not shown include medium voltage transfer, high resistance ground and low profile switchgear.

^② Listings are voltage dependant. See individual product sheets for detail.

Product Offering Chart—Metal-Clad ^①

Description	MVA Standard	Narrow Design	MVA Arc Resistant
Voltage	5, 15, 27, 38 kV	5 kV	5, 15, 27, 38 kV
Operation duty cycle	High	High	High
Enclosure	Indoor (5–38 kV)	Indoor only	Indoor only
	Outdoor aisleless (5–27 kV)	Outdoor aisle	
	Outdoor aisle (5–15 kV)		
	Outdoor common aisle (5–15 kV)		
Listed	UL, CSA	UL, CSA	CSA only
Assembly standards	ANSI/IEEE, C37.04, C37.06, C37.54, C37.20.2, C37.55, CSA 22.2 #31 ^②	ANSI/IEEE, C37.04, C37.06, C37.54, C37.20.2, C37.55, CSA 22.2 #31 ^②	ANSI/IEEE, C37.04, C37.06, C37.54, C37.20.2, C37.20.7, C37.55, CSA 22.2 #31 ^②
Circuit breaker type	VCP-W	VCP-W ND	VCP-W
Circuit breaker mounted	5 kV drawout, direct roll-in breaker option	Drawout 5 kV only	5 kV drawout, direct roll-in breaker option
	15 kV drawout, direct roll-in breaker option		15 kV drawout, direct roll-in breaker option
	27 kV drawout, direct roll-in breaker option		27 kV drawout, direct roll-in breaker option
	38 kV direct roll-in breakers		38 kV direct roll-in breakers
Seismically rated Zone 4 to California Building Code Title 24	Yes	Yes	Yes
BIL ratings	60 kV (5 kV)	60 kV (5 kV only)	60 kV (5 kV)
	95 kV (15 kV)		95 kV (15 kV)
	125 kV (27 kV)		125 kV (27 kV)
	170 kV (38 kV)		170 kV (38 kV)
Main bus ratings	1200, 2000, 3000, 4000A (5 kV)	1200A (5 kV only)	1200, 2000, 3000A (5 kV)
	1200, 2000, 3000, 4000A (15 kV)	2000A, 3000A	1200, 2000, 3000A (15 kV)
	1200, 2000A (27 kV)		1200, 2000A (27 kV)
	1200, 2000, 3000A depending on kA rating (38 kV)		1200, 2000, 3000A (38 kV)
Breaker ratings	1200, 2000, 3000A (5 kV)	1200A (5 kV only)	1200, 2000, 3000A (5 kV)
	1200, 2000, 3000A (15 kV)		1200, 2000, 3000A (15 kV)
	1200, 2000A (27 kV)		1200, 2000A (27 kV)
	1200, 1600, 2500A depending on kA rating (38 kV)		1200A (38 kV)
Overcurrent protective device	Yes	Yes	Yes
Short-circuit interrupting capacity	29, 41, 63 kA (5 kV)	29 kA (5 kV)	37 kA (5 kV) ^③
	33 kA (8.25 kV)		—
	18, 28, 37, 63 kA		37 kA (15 kV) ^③
	16, 22, 25, 40 kA		25 kA (27 kV) ^③
	16, 21, 25, 32, 40 kA (38 kV)		25 kA (38 kV) ^③
			40, 50, 63 kA (5 kV) ^③
		40, 50, 63 kA (15 kV) ^③	
		25, 40 kA (27 kV) ^③	
		25, 40 kA (38 kV) ^③	
Conduit Entry	Top or bottom	Top or bottom	Top or bottom

Notes

- ① Additional products not shown include medium voltage transfer, high resistance ground and low profile switchgear.
- ② Listings are voltage dependant. See individual product sheets for detail.
- ③ Ratings are arc ratings, not interrupting capacity.

VCP-W Breaker



7

Contents

Description

	<i>Page</i>
Product Overview	
Features, Benefits and Functions	V3-T7-5
Options and Accessories	V3-T7-6
Technical Data and Specifications	V3-T7-6
26-Inch Wide, 5 kV, 250 MVA, 1200A Switchgear .	V3-T7-7
38 kV Metal-Clad Switchgear	V3-T7-8

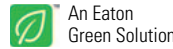

Product Overview

Product Description

Eaton has been manufacturing metal-clad switchgear for over 50 years, and vacuum circuit breakers for over 30 years. Tens of thousands of Eaton vacuum circuit breakers, used in a wide variety of applications, have been setting industry performance standards for years.

With reliability as a fundamental goal, Eaton's engineers have simplified the VCP-W switchgear design to minimize problems and gain trouble-free performance. Special attention was given to material quality and maximum possible use was made of components proven over the years in Eaton switchgear.

Maintenance requirements are minimized by the use of enclosed long-life vacuum interrupters. When maintenance or inspection is required, the component arrangements and drawers allow easy access. The VCP-W's light weight simplifies handling and relocation of the breakers.

The VCP-W meets or exceeds all applicable ANSI, NEMA® and IEEE design standards, and additionally offers many outstanding safety features. To ensure reliability and quality, the testing of VCP-W switchgears has been extensive. UL and CSA listed switchgear is available for 5 and 15 kV. CSA is available for 27 and 38 kV.

Application Description

Eaton's VCP-W metal-clad switchgear with type VCP-W vacuum breakers provides centralized control and protection of medium voltage power equipment and circuits in industrial, commercial and utility installations involving generators, motors, feeder circuits, and transmission and distribution lines.

VCP-W switchgear is available in maximum voltage ratings from 4.76 kV through 38 kV, and interrupting ratings as shown on **Page V3-T7-11**. VCP-W offers a total design concept of cell, breaker and auxiliary equipment, which can be assembled in various combinations to satisfy user application requirements. Two-high breaker arrangements are standard up to 15 kV. One-high arrangements can be furnished when required.

Features, Benefits and Functions

Endurance

High power laboratory tests prove VCP-W breakers are capable of 50 to 200 full fault current interruptions.

Space Savings

Up to 50% floor space reduction over previous designs.

Vacuum Interrupter, Current Transfer Conductor

Eaton's stiff-flexible design eliminates sliding/rolling contacts in the main conductor, which provides excellent electrical and thermal transfer, and long vacuum interrupter life.

Grounded Steel Safety Shutters

Prevents accidental contact with live primary voltage connections when breaker is withdrawn.

Breaker Rails

On 5–27 kV units, the breaker can be withdrawn on rails for inspection and maintenance without the need for a separate lifting device.

Direct Roll-In Breakers

5–27 kV switchgear is available with direct roll-in breakers. Direct roll-in breakers can be supplied in two-high configurations with fully interchangeable breakers. Rails or a special direct roll-in lift pan can be used if desired to withdraw upper breakers for inspection.

Reduced Breaker Weight

525 lbs (238 kg) maximum through 27 kV vs. 2450 lbs (1112 kg) in a comparable air-magnetic design for ease of handling.

Reduced Breaker Maintenance

Vacuum interrupter requires only periodic check for contact erosion. Integral wear indicator provided. No contact adjustments are required.

Front Accessible Mechanism

Front accessible mechanism is standard on all VCP-W breakers.

Front Accessible CTs (5–38 kV)

Up to 12 CTs per breaker can be mounted for easy access.

Drawout Auxiliary Compartments

Up to four drawers per vertical section can be equipped with CPTs or VTs up to 15 kV. Primary isolation shutters are standard.

Fluidized Bed Epoxy Bus Insulation

Excellent track resistant and flame retardant properties.

Standardized Functional Designs

Shortens order cycle time.

Protective Relays

A full scope of protective relays designed to meet all application requirements is available to provide the utmost in system and component protection. One such multipurpose relay system is Eaton's Digitrip™ FP-5000. FP-5000 enhanced capabilities include auto-throver schemes, voltage and current protection, and communication. This microprocessor-based circuit protective, control and monitoring relay system includes devices 50, 51, 50N, 51N, 50G, 51G and 86, plus cause and magnitude of trip, integral test and programming, ampere demand, high load alarm, non-volatile set points, self-testing and communications capabilities. The Digitrip is capable of being monitored and controlled through PowerNet™, DeviceNet™, Ethernet and Web PONIs. Refer to **Volume 3, Tab 9** for further information.

PowerNet—Integrated Monitoring Protection and Control Communications System

Medium voltage VCP-W switchgear is ideally suited for Eaton's unique PowerNet system.

PowerNet is the unique system that, for the first time, ties together multiple devices in electrical distribution systems in a wide variety of buildings and plants.

PowerNet uses the proven, INCOM™ chip for highly reliable, two-way communications (even in noisy industrial environments) between the master control unit and system devices via a twisted pair of conductors. Communications wires can be extended up to 10,000 feet (3.04m) from the master control unit without repeaters...and as many as 1000 compatible devices, installed in various assemblies, can be on the PowerNet system.

Easy Installation

Installation is uncomplicated and devices are connected, daisy chain style, via the twisted pair conductors. All assemblies and devices are standard Eaton equipment when PowerNet compatible devices are ordered as part of an assembly. The assemblies (with compatible devices built in) are prewired, pretested and delivered complete.

Flexibility

PowerNet is flexible in that it can include those assemblies, such as VCP-W switchgear, that are desired in a distribution system... but PowerNet can be easily upgraded as new assemblies are added. In essence, a customer determines the requirements for a building's electrical distribution system, and Eaton provides the PowerNet system to fit those specific requirements.

Environmentally-Friendly

Eaton's medium voltage switchgear uses vacuum switches combined with solid insulation material. This environmentally-friendly technology avoids the use of SF₆ as an insulation gas, and can offer a lower total cost of ownership over the complete life cycle of your medium voltage equipment.

Options and Accessories

Supplemental Devices

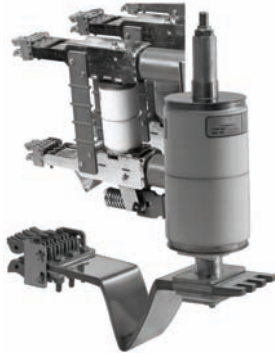

World-Class VCP-W Vacuum Circuit Breakers are Designed with a V-Flex Nonsliding Current Transfer System

Ground and Test Device

The ground and test device is a drawout element that may be inserted into a metal-clad switchgear housing in place of a circuit breaker to provide access to the primary circuits to permit the temporary connection of grounds or testing equipment to the high voltage circuits. High potential testing of cable or phase checking of circuits are typical tests that may be performed. The devices are insulated to suit the voltage rating of the switchgear and will carry required levels of short-circuit current.

Before using ground and test devices, it is recommended that each user develop detailed operating procedures consistent with safe operating practices. Only qualified personnel should be authorized to use ground and test devices.

Manual and electrical ground and test devices are available. These devices include six studs for connection to primary circuits. On the manual device, selection and grounding is accomplished by cable connection. On the electrical-type device, grounding is accomplished by an electrically operated grounding switch.

Standard Accessories

- One test jumper
- One levering crank
- One maintenance tool
- One lifting yoke (5–38 kV)
- Two sets of rails (5–27 kV)
- One turning handle (5th wheel, 38 kV)

Optional Accessories

- One transport dolly (5–27 kV)
- One portable lifter (5–27 kV)
- One test cabinet
- One electrical levering device (5–27 kV)
- One ramp for lower breaker (5–27 kV)
- One manual or electrical ground and test device. Electrical ground up to 15 kV only
- One hi-pot tester
- One offset manual racking device

Technical Data and Specifications

- Maximum voltages:
 - 4.76 kV, 8.25 kV, 15 kV, 27 kV, 38 kV
- Interrupting ratings:
 - 4.76 kV:
 - 250 MVA (29 kA)
 - 350 MVA (41 kA)
 - 500 MVA (63 kA)
 - 8.25 kV:
 - 500 MVA (33 kA)
 - 15 kV:
 - 500 MVA (18 kA)
 - 750 MVA (28 kA)
 - 1000 MVA (37 kA)
 - 1500 MVA (63 kA)
 - 27 kV:
 - 16 kA, 22 kA, 25 kA, 40 kA
 - 38 kV:
 - 16 kA, 25 kA, 31.5 kA, 40 kA
 - 2300 MVA (35 kA)
- Continuous current: circuit breakers
 - 1200A, 2000A, 3000A (5 and 15 kV)
 - 4000A forced cooled (5 and 15 kV)
 - 1200A, 2000A, (27 kV)
 - 600A, 1200A, 1600A, 200A, 2500A (38 kV)
 - 3000A forced cooled (38 kV)
- Continuous current: main bus
 - 1200A, 2000A, 3000A, 4000A (5 and 15 kV)
 - 1200A, 2000A, (27 kV)
 - 1200A, 2000A, 2500A, 3000A (38 kV)

Typical Indoor Assembly with a Breaker Withdrawn on Rails



Contents

Description	Page
Product Overview	V3-T7-4
26-Inch Wide, 5 kV, 250 MVA, 1200A Switchgear	
38 kV Metal-Clad Switchgear	V3-T7-8

26-Inch Wide, 5 kV, 250 MVA, 1200A Switchgear

Product Description

26-inch wide VCP-W switchgear was designed for use in instances where floor space requirements would not allow the industry standard 36-inch (914.4 mm) wide switchgear.

Application Description

Typical applications include not only new construction, but also replacement switchgear for installations previously equipped with 26-inch (660.4 mm) wide airbreak devices. This new line of switchgear has also proven very popular among Generator Control manufacturers where 5 kV, 250 MVA, 1200A applications are commonplace.

Features, Benefits and Functions

Functionality is the name of the game. Available configurations include breaker over breaker, one or two auxiliaries over breaker, breaker over one or two auxiliaries, or up to four auxiliaries in one vertical section.

In addition to the tremendous floor space saving offered by the 26-inch (660.4 mm) wide design, a savings in the height of the switchgear is also available. Where height is an issue, such as an outdoor powerhouse or in a mobile power container, the standard 95-inch (2413 mm) height can be reduced to an 80-inch (2032 mm) tall model with a single-high breaker with one auxiliary and/or control cubical. In addition, the low-profile structure is designed to accommodate Voltage Transformers that are front mounted. Shallow-depth versions are also available for applications where depth is an issue. Contact your local Eaton representative for more information on special dimensional requirements.

For installations requiring 2000A main breakers with 1200A feeders, lineups can be built with standard 36-inch (914.4 mm) wide main breaker cubicles and 26-inch (660.4 mm) wide feeders. The main bus connections are 100% compatible with standard 36-inch (914.4 mm) wide vertical sections. As a result, add-ons to existing installations can be simply and rapidly performed without costly system modifications and transition sections.

Standards and Certifications

At the heart of the new switchgear line is Eaton's world-class VCPW-ND "Narrow Design" vacuum circuit breaker. The 26-inch (660.4 mm) wide offering includes breakers and gear that are rated for use on 5 kV, 250 MVA, 1200A, 60 kV BIL maximum systems. Main bus ratings of up to 2000A are available.

The 26-inch (660.4 mm) wide VCP-W switchgear meets or exceeds ANSI, NEMA and IEEE design standards. UL and CSA listed switchgear is also available.



Typical Indoor Switchgear Unit



Contents

<i>Description</i>	<i>Page</i>
Product Overview	V3-T7-4
26-Inch Wide, 5 kV, 250 MVA, 1200A Switchgear	V3-T7-7
38 kV Metal-Clad Switchgear	
Technical Data and Specifications	V3-T7-9

38 kV Metal-Clad Switchgear

Product Description

This member of the Eaton's VCP-W switchgear family was designed for use in applications with distribution voltages at 38 kV maximum.

Application Description

Typical applications include not only new construction, but also replacement for older airbreak, minimum oil or SF₆ switchgear. This line is available in two basic versions: one designed specifically for domestic and export ANSI applications (VCP-W), with a continuous current range of 600–2500A; and one built for export only IEC applications (W-VAC) for continuous current ranges of 630–2500A.

Features, Benefits and Functions

Both ANSI and IEC versions offer 40 kA rms symmetrical momentary short-circuit, 80 kV 1 minute withstand, 170 kV BIL ratings as standard, and both feature a revolutionary interface design that permits crossover and transition bus connections to adjacent sections without the need for a transition section. Standard dimensions of this 170 kV BIL gear is 42 inches wide x 100 inches tall x 128.8 inches deep (1066.8 mm wide x 2540 mm tall x 3270.3 mm deep), making the VCP-W offering the smallest in its class.

Safety has been thoroughly addressed in the design of the 38 kV VCP-W. On all standard units, shutters can be independently padlocked to prevent inadvertent energizing during maintenance. Where needed, fully rated feeder earthing switches are also available.

Ease of service is another benefit. All 38 kV switchgear units are equipped with roll-on-the-floor vacuum circuit breakers that provide both unprecedented mobility and ready accessibility to the breaker cell. Levering-in mechanisms for breaker installation employ an innovative ball-screw bearing drive that can be operated by a single technician.

The 38 kV line can be equipped with a variety of optional features to enhance system protection and monitoring. Eaton's Digitrip FP-5000 microprocessor-based trip system, IQ Analyzer and the PowerNet communications system are all available with the 38 kV metal-clad switchgear.

Standards and Certifications

Both ANSI and IEC designs are designed and tested at the factory to be corona-free. In addition, optional arc-resistant designs can be specified to comply with EEMAC G-14-1 for Accessibility Types A and B.

CSA listed switchgear is also available.



Technical Data and Specifications

Available Type VCP-W Vacuum Circuit Breakers Rated on Symmetrical Current Basis, Per ANSI Standards (Rated K=1)

Rated Values	Drawout Circuit Breaker Type				
	50 VCP-W 25	50 VCP-W 40	50 VCP-W 50	50 VCP-W 63	75 VCP-W 40
Maximum voltage (V) (kV rms)	4.76	4.76	4.76	4.76	8.25
Power frequency (Hz) ①	60	60	60	60	60
Insulation level					
Power frequency withstand voltage (1 min.) (kV rms)	19	19	19	19	36
Lightning impulse withstand voltage (1.2 x 50 ms) (kV peak)	60	60	60	60	95
Continuous current (A rms) ②	1200 2000 3000	1200 2000 3000	1200 2000 3000	1200 2000 3000	1200 2000 3000
Short-circuit ratings (reference C37.04-1999 and C37.06-2009 except as noted ③)					
Symmetrical interrupting circuit (I) (kA rms sym) ④	25	40	50	63	40
DC component (%DC) (%) ⑤	50	50	44	55	50
Asymmetrical interrupting current (I _a) (kA rms asym total) ⑥	31	49	59	80	49
Closing and latching current (2.6 x I) (kA peak)	65	104	130	164	104
Short-time withstand current (rms) ⑦	25	40	50	63	40
Transient recovery voltage parameters are based on TD-4					
Peak voltage (E ₂) = (u _c) (kV peak)	8.2	8.2	8.2	8.2	14
Time to peak (T ₂ = t ₃ x 1.137) (msec)	50	50	50	50	59
TRV rise time (t ₃) (msec)	44	44	44	44	52
RRRV = u _c /t ₃ (kV/msec) ⑧	0.19	0.19	0.19	0.19	0.27
Interrupting time (ms, cycles (60 Hz))	50, 3	50, 3	50, 3	50, 3	50, 3
Operating duty (duty cycle)	0-0.3s-CO-3m-CO	0-0.3s-CO-3m-CO	0-0.3s-CO-3m-CO	0-0.3s-CO-3m-CO	0-0.3s-CO-3m-CO
Mechanical endurance (no-load operations) ⑨⑩	10,000	10,000	10,000	10,000	10,000
Capacitance current switching capability (reference C47.04a-2003, C37.06-2009 and C37.09a-2005)					
Cable-charging current (class, A rms)	C2, 3-10	C2, 3-10	C2, 3-10	C2, 7.5-25	C2, 7.5-25
Isolated shunt capacitor bank current (class, A rms)	C2, 75-630 75-1000 75-1600	C2, 75-630 75-1000 75-1600	C2, 75-630 75-1000 75-1600	C2, 75-630 75-1000 75-1600	C2, 75-630 75-1000 75-1600
Back-to-back capacitor switching					
Capacitor bank current (class, A rms)	C2, 75-630 75-1000 75-1600	C2, 75-630 75-1000 75-1600	C2, 75-630 75-1000 75-1600	C2, 75-630 75-1000 75-1600	C2, 75-630 75-1000 75-1600
Inrush current (kA peak)	6	6	6	6	6
Inrush frequency (kHz)	0.8 0.5 0.3	0.8 0.5 0.3	0.8 0.5 0.3	0.8 0.5 0.3	0.8 0.5 0.3
Out-of-phase switching					
Voltage = 1.44 x V (kV rms)	7	7	7	7	12
Current = 0.25 x I (kA rms)	6.3	10	12.5	15.8	10

Notes

- ① All circuit breakers are tested at 60 Hz, however, they can also be applied at 50 Hz with no de-rating.
- ② 4000A fan cooled rating is available for 3000A circuit breakers.
- ③ These circuit breakers were tested to the preferred TRV ratings specified in C37.06-2000.
- ④ Because the voltage range factor K=1, the short-time withstand current and the maximum symmetrical interrupting current are equal to the rated symmetrical interrupting current.
- ⑤ Based on the standard DC TIME constant of 45 ms (corresponding to X/R of 17 for 60 Hz) and the minimum contact parting time as determined from the minimum opening time plus the assumed minimum relay time of 1/2 cycle (8.33 ms for 60 Hz).
- ⑥ The asymmetrical interrupting current, I total, is given by $I_t = I \times \text{Sqrt}(1 + 2 \times \%DC \times \%DC)$ kA rms asym total.
- ⑦ Duration of short-time current and maximum permissible tripping delay are both two seconds for all circuit breakers listed in this table, as required in C37.04-1999, C37.06-2000 and C37.06-2009.
- ⑧ RRRV can also be calculated as $= 1.137 \times E_2/T_2$.
- ⑨ Each operation consists of one closing plus one opening.
- ⑩ All 40 and 50 kA circuit breakers exceed required 5000 no-load operations; all 63 kA circuit breakers exceed the required 2000 no-load ANSI operations.

Available Type VCP-W Vacuum Circuit Breakers Rated on Symmetrical Current Basis, Per ANSI Standards (Rated K=1), continued

Rated Values	Drawout Circuit Breaker Type				
	75 VCP-W 50	150 VCP-W 25	150 VCP-W 40	150 VCP-W 50	150 VCP-W 63
Maximum voltage (V) (kV rms)	8.25	15	15	15	15
Power frequency (Hz) ①	60	60	60	60	60
Insulation level					
Power frequency withstand voltage (1 min.) (kV rms)	36	36	36	36	36
Lightning impulse withstand voltage (1.2 x 50 ms) (kV peak)	95	95	95	95	95
Continuous current (A rms) ②	1200 2000 3000	1200 ③ 2000 3000	1200 2000 3000	1200 2000 3000	1200 ③ 2000 ③ 3000 ③
Short-circuit ratings (reference C37.04-1999 and C37.06-2009 except as noted ③)					
Symmetrical interrupting current (I) (kA rms sym) ④	50	25	40	50	63
DC component (%DC) (%) ⑤	44	50	50	44	55
Asymmetrical interrupting current (I _a) (kA rms asym total) ⑥	59	31	49	59	80
Closing and latching current (2.6 x I) (kA peak)	130	65	104	130	164
Short-time withstand current (rms) ⑦	50	25	40	50	63
Transient recovery voltage parameters are based on TD-4					
Peak voltage (E ₂) = (u _c) (kV peak)	14	28 ⑧ 25.7	25.7	25.7	28 ⑧
Time to peak (T ₂ = t ₃ x 1.137) (msec)	59	75	75	75	75
TRV rise time (t ₃) (msec)	52	66	66	66	66
RRRV = u _c /t ₃ (kV/msec) ⑨	0.27	0.42 0.39	0.39	0.39	0.42
Interrupting time (ms, cycles (60 Hz))	50, 3	50, 3	50, 3	50, 3	50, 3
Operating duty (duty cycle)	0-0.3s-CO-3m-CO	0-0.3s-CO-3m-CO	0-0.3s-CO-3m-CO	0-0.3s-CO-3m-CO	0-0.3s-CO-3m-CO
Mechanical endurance (no-load operations) ⑩⑪	10,000	10,000	10,000	10,000	10,000
Capacitance current switching capability (reference C47.04a-2003, C37.06-2009 and C37.09a-2005)					
Cable-charging current (class, A rms)	C2, 7.5–25	C2, 7.5–25	C2, 7.5–25	C2, 7.5–25	C2, 7.5–25
Isolated shunt capacitor bank current (class, A rms)	C2, 75–630 75–1000 75–1600	C2, 75–630 C2, 75–1000 C1, 75–1000	C2, 75–630 C2, 75–1000 C1, 75–1600	C2, 75–630 C2, 75–1000 C1, 75–1600	C2, 75–630 75–1000 75–1600
Back-to-back capacitor switching					
Capacitor bank current (class, A rms)	C2, 75–630 75–1000 75–1600	C2, 75–630 C2, 75–1000 C1, 75–1000	C2, 75–630 C2, 75–1000 C1, 75–1600	C2, 75–630 C2, 75–1000 C1, 75–1600	C2, 75–630 75–1000 75–1600
Inrush current (kA peak)	6	6	6	6	6
Inrush frequency (kHz)	0.8 0.5 0.3	0.8 0.5 0.3	0.8 0.5 0.3	0.8 0.5 0.3	0.8 0.5 0.3
Out-of-phase switching					
Voltage = 1.44 x V (kV rms)	12	22	22	22	22
Current = 0.25 x I (kA rms)	12.5	6.3	10	12.5	15.8

Notes

- ① All circuit breakers are tested at 60 Hz, however, they can also be applied at 50 Hz with no de-rating.
- ② 4000A fan cooled rating is available for 3000A circuit breakers.
- ③ These circuit breakers were tested to the preferred TRV ratings specified in C37.06-2000.
- ④ Because the voltage range factor K=1, the short-time withstand current and the maximum symmetrical interrupting current are equal to the rated symmetrical interrupting current.
- ⑤ Based on the standard DC time constant of 45 ms (corresponding to X/R of 17 for 60 Hz) and the minimum contact parting time as determined from the minimum opening time plus the assumed minimum relay time of 1/2 cycle (8.33 ms for 60 Hz).

- ⑥ The asymmetrical interrupting current, I total, is given by $I_a = I \times \text{Sqrt}(1 + 2 \times \%DC \times \%DC)$ kA rms asym total.
- ⑦ Duration of short-time current and maximum permissible tripping delay are both two seconds for all circuit breakers listed in this table, as required in C37.04-1999, C37.06-2000 and C37.06-2009.
- ⑧ RRRV can also be calculated as $= 1.137 \times E_2/T_2$.
- ⑨ Each operation consists of one closing plus one opening.
- ⑩ All 40 and 50 kA circuit breakers exceed required 5000 no-load operations; all 63 kA circuit breakers exceed the required 2000 no-load ANSI operations.

Available VCP-W Vacuum Circuit Breaker Types Rated on Symmetrical Current Rating Basis, Per ANSI Standards ①②

	Circuit Breaker Type							
	50 VCP-WND 250	50 VCP-W 250	50 VCP-W 350	50 VCP-W 63	75 VCP-W 500	150 VCP-W 500	150 VCP-W 750	150 VCP-W 1000
Identification								
Nominal voltage class kV	4.16	4.16	4.16	4.16	7.2	13.8	13.8	13.8
Nominal three-phase MVA class	250	250	350	—	500	500	750	1000
Rated Values								
Voltage								
Rated maximum voltage V kV rms	4.76	4.76	4.76	4.76	8.25	15	15	15
Rated voltage range factor K ③	1.24	1.24	1.19	1.0	1.25	1.30	1.30	1.30
Insulation level—rated withstand test voltage								
Normal frequency kV rms	19	19	19	19	36	36	36	36
1.2 x 50 μsec. impulse kV crest	60	60	60	60	95	95	95	95
Current								
Rated continuous current at 60 Hz amp ④	1200	1200	1200	1200	1200	1200	1200	1200
	—	2000	2000	2000	2000	2000	2000	2000
	—	3000	3000	3000	3000	3000	3000	3000
Rated short-circuit current (at rated maximum kV)—I kA rms ⑤	29	29	41	63	33	18	28	37
Rated transient recovery voltage								
Rated crest voltage —E ₂ kV crest	8.9	8.9	8.9	8.9	15.5	28	28	28
Rated time to crest—T ₂ μs	50	50	50	50	60	75	75	75
Rate of rise of recovery voltage kV/μs ⑥	0.2	0.2	0.2	0.2	0.29	0.42	0.42	0.42
Rated interrupting time cycles ⑥	5	5	5	5	5	5	5	5
Rated permissible tripping delay—Y sec. ⑦	2	2	2	2	2	2	2	2
Rated reclosing time ms ⑧	300	300	300	300	300	300	300	300
Related Required Capabilities								
Rated maximum voltage divided by K—V/K kV rms	3.85	3.85	4.0	4.76	6.6	11.5	11.5	11.5
Current values								
K times rated short-circuit current ③								
Maximum sym. interrupting capability—KI kA rms	36	36	49	63	41	23	36	48
Three-second short-time current carrying capability—KI kA rms	36	36	49	63	41	23	36	48
Closing and latching capability (momentary) ⑨								
2.7K times rated short-circuit current—2.7 KI kA crest	97	97	132	170	111	62	97	130
1.6K times rated short-circuit current—1.6 KI kA rms asym. ⑩	58	58	78	101	66	37	58	77
Asymmetry Factor for VCP-W Breakers (S) ⑪	1.2	1.2	1.2	1.27	1.2	1.2	1.2	1.2

Notes

- ① For capacitor switching, refer to **Page V3-T7-14**.
- ② 5 and 15 kV circuit breakers are UL listed. 27 and 38 kV breakers are not UL listed.
- ③ For three-phase and line-to-line faults, the symmetrical interrupting capability at an operating voltage

$$I_{sc} = \frac{V}{V_0} \text{ (Rated Short-Circuit Current)}$$

But not to exceed KI.

Single line-to-ground fault capability at an operating voltage

$$I_{sc} = 1.15 \frac{V}{V_0} \text{ (Rated Short-Circuit Current)}$$

But not to exceed KI.

The above apply on predominately inductive or resistive three-phase circuits with normal-frequency line-to-line recovery voltage equal to the operating voltage.

- ④ 4000A continuous rating is available for 5/15 kV. 3000A continuous rating is available for 38 kV. Contact Eaton for details.

$$\text{⑤ } RRRV = 1.137 \frac{E_2}{T_2}$$

- ⑥ Three-cycle rating available, refer to **Page V3-T7-14**.

- ⑦ Tripping may be delayed beyond the rated permissible tripping delay at lower values of current in accordance with the following formula:

$$T \text{ (seconds)} = Y \left(\frac{\text{(K Times Rated Short-Circuit Current)}}{\text{Short-Circuit Current Through Breaker}} \right)^2$$

The aggregate tripping delay on all operations within any 30-minute period must not exceed the time obtained from the above formula.

- ⑧ For reclosing service, there is **No De-Rating** necessary Eaton's VCP-W family of circuit breakers. **R = 100%**. Type VCP-W breaker can perform the O-C-O per ANSI C37.09; O-0.3s-CO-15s-CO per IEC 56; and some VCP-Ws have performed O-0.3s-CO-15s-CO-15s-CO-15s-CO; **all with no derating**. Contact Eaton for special reclosing requirements.
- ⑨ For higher close and latch ratings, refer to **Page V3-T7-14**.
- ⑩ Included for reference only.
- ⑪ Asymmetrical interrupting capability = "S" times symmetrical interrupting capability, both at specified operating voltage.

Available VCP-W Vacuum Circuit Breaker Types Rated on Symmetrical Current Rating Basis, Per ANSI Standards, continued ①②

	Circuit Breaker Type				
	150 VCP-W 63	270 VCP-W 750	270 VCP-W 1000	270 VCP-W 1250	270 VCP-W 40
Identification					
Nominal voltage class kV	13.8	27	27	27	27
Nominal three-phase MVA class	—	—	—	—	—
Rated Values					
Voltage					
Rated maximum voltage kV rms	15	27	27	27	27
Rated voltage range factor K ③	1.0	1.0	1.0	1.0	1.0
Insulation level—rated withstand test voltage					
Normal frequency kV rms	36	60	60	60	60
1.2 x 50 μsec. impulse kV crest	95	125	125	125	125
Current					
Rated continuous current at 60 Hz amp ④	1200	600	600	600	1200
	2000	1200	1200	1200	2000
	3000	2000	2000	2000	—
Rated short-circuit current (at rated maximum kV)—I kA rms ⑤	63	16	22	25	40
Rated transient recovery voltage					
Rated crest voltage—E ₂ kV crest	28	51	51	51	51
Rated time to crest—T ₂ μs	75	105	105	105	105
Rate of rise of recovery voltage kV/μs ⑥	0.42	0.55	0.55	0.55	0.55
Rated interrupting time cycles ⑦	5	5	5	5	5
Rated permissible tripping delay—Y sec. ⑦	2	2	2	2	2
Rated reclosing time ms ⑧	300	300	300	300	300
Related Required Capabilities					
Rated maximum voltage divided by K—V/K kV rms	15	27	27	27	27
Current values					
K times rated short-circuit current ③					
Maximum sym. interrupting capability—KI kA rms	63	16	22	25	40
Three-second short-time current carrying capability—KI kA rms	63	16	22	25	40
Closing and latching capability (momentary) ⑨					
2.7K times rated short-circuit current—2.7 KI kA crest	170	43	60	68	108
1.6K times rated short-circuit current—1.6 KI kA rms asym. ⑩	100	26	35	40	64
Asymmetry Factor for VCP-W Breakers (S) ⑪	1.27	1.2	1.2	1.2	1.2

Notes

- ① For capacitor switching, refer to **Page V3-T7-14**.
 ② 5 and 15 kV circuit breakers are UL listed. 27 and 38 kV breakers are not UL listed.
 ③ For three-phase and line-to-line faults, the symmetrical interrupting capability at an operating voltage

$$I_{sc} = \frac{V}{V_0} \text{ (Rated Short-Circuit Current)}$$

But not to exceed KI.

Single line-to-ground fault capability at an operating voltage

$$I_{sc} = 1.15 \frac{V}{V_0} \text{ (Rated Short-Circuit Current)}$$

But not to exceed KI.

The above apply on predominately inductive or resistive three-phase circuits with normal-frequency line-to-line recovery voltage equal to the operating voltage.

- ④ 4000A continuous rating is available for 5/15 kV. 3000A continuous rating is available for 38 kV. Contact Eaton for details.

$$\textcircled{6} \text{ RRRV} = 1.137 \frac{E_2}{T_2}$$

- ⑤ Three-cycle rating available, refer to **Page V3-T7-14**.

- ⑦ Tripping may be delayed beyond the rated permissible tripping delay at lower values of current in accordance with the following formula:

$$T \text{ (seconds)} = Y \left(\frac{K \text{ Times Rated Short-Circuit Current}}{\text{Short-Circuit Current Through Breaker}} \right)^2$$

The aggregate tripping delay on all operations within any 30-minute period must not exceed the time obtained from the above formula.

- ⑧ For reclosing service, there is **No De-Rating** necessary for Eaton's VCP-W family of circuit breakers. **R = 100%**. Type VCP-W breaker can perform the O-C-O per ANSI C37.09; O-0.3s-CO-15s-CO per IEC 56; and some VCP-Ws have performed O-0.3s-CO-15s-CO-15s-CO-15s-CO; **all with no derating**. Contact Eaton for special reclosing requirements.
 ⑨ For higher close and latch ratings, refer to **Page V3-T7-14**.
 ⑩ Included for reference only.
 ⑪ Asymmetrical interrupting capability = "S" times symmetrical interrupting capability, both at specified operating voltage.

Available VCP-W Vacuum Circuit Breaker Types Rated on Symmetrical Current Rating Basis, Per ANSI Standards, continued ^{①②}

	Circuit Breaker Type				
	380 VCP-W 16	380 VCP-W 21	380 VCP-W 25	380 VCP-W 32	380 VCP-W 40
Identification					
Nominal voltage class kV	34.5	34.5	34.5	34.5	34.5
Nominal three-phase MVA class	—	—	—	—	—
Rated Values					
Voltage					
Rated maximum voltage kV rms	38	38	38	38	38
Rated voltage range factor K ^③	1.0	1.65	1.0	1.0	1.0
Insulation level—rated withstand test voltage Normal frequency kV rms					
	80	80	80	80	80
1.2 x 50 μsec. impulse kV crest ^④	170 ^⑤	170 ^⑤	170 ^⑤	170 ^⑤	170 ^⑤
Current					
Rated continuous current at 60 Hz amp ^④	600	1200	600	600	600
	1200	2000	1200	1200	1200
	1600	—	1600	1600	1600
	2000	—	2000	2000	2000
	—	—	—	2500	2500
Rated short-circuit current (at rated maximum kV)—I kA rms ^③	16	21	25	31.5	40
Rated transient recovery voltage					
Rated crest voltage —E ₂ kV crest	71	71	71	71	71
Rated time to crest—T ₂ μs	125	125	125	125	125
Rate of rise of recovery voltage kV/μs ^⑤	0.64	0.64	0.64	0.64	0.64
Rated interrupting time cycles ^⑥	5	5	5	5	5
Rated permissible tripping delay—Y sec. ^⑦	2	2	2	2	2
Rated reclosing time ms ^⑧	300	300	300	300	⑨
Related Required Capabilities					
Rated maximum voltage divided by K—V/K kV rms	38	23	38	38	38
Current values					
K times rated short-circuit current ^③					
Maximum sym. interrupting capability—KI kA rms	16	35	25	31.5	40
Three-second short-time current carrying capability—KI kA rms	16	35	25	31.5	40
Closing and latching capability (momentary) ^⑩					
2.7K times rated short-circuit current—2.7 KI kA crest	43	95	68	85	108
1.6K times rated short-circuit current—1.6 KI kA rms asym. ^⑪	26	56	40	51	64
Asymmetry Factor for VCP-W Breakers (S) ^⑫	1.2	1.2	1.2	1.2	1.2

Notes

- ① For capacitor switching, refer to **Page V3-T7-14**.
- ② 5 and 15 kV circuit breakers are UL listed. 27 and 38 kV breakers are not UL listed.
- ③ For three-phase and line-to-line faults, the symmetrical interrupting capability at an operating voltage

$$I_{sc} = \frac{V}{V_0} \text{ (Rated Short-Circuit Current)}$$

But not to exceed KI.

Single line-to-ground fault capability at an operating voltage

$$I_{sc} = 1.15 \frac{V}{V_0} \text{ (Rated Short-Circuit Current)}$$

But not to exceed KI.

The above apply on predominately inductive or resistive three-phase circuits with normal-frequency line-to-line recovery voltage equal to the operating voltage.

- ④ 4000A continuous rating is available for 5/15 kV. 3000A continuous rating is available for 38 kV. Contact Eaton for details.
- ⑤ $RRRV = 1.137 \frac{E_2}{T_2}$

- ⑥ Three-cycle rating available, refer to **Page V3-T7-14**.

- ⑦ Tripping may be delayed beyond the rated permissible tripping delay at lower values of current in accordance with the following formula:

$$T \text{ (seconds)} = Y \left(\frac{K \text{ Times Rated Short-Circuit Current}}{\text{Short-Circuit Current Through Breaker}} \right)^2$$

The aggregate tripping delay on all operations within any 30-minute period must not exceed the time obtained from the above formula.

- ⑧ For reclosing service, there is **No De-Rating** necessary for Eaton's VCP-W family of circuit breakers. **R = 100%**. Type VCP-W breaker can perform the O-C-O per ANSI C37.09; O-0.3s-CO-15s-CO per IEC 56; and some VCP-Ws have performed O-0.3s-CO-15s-CO-15s-CO-15s-CO; **all with no derating**. Contact Eaton for special reclosing requirements.
- ⑨ For higher close and latch ratings, refer to **Page V3-T7-14**.
- ⑩ Included for reference only.
- ⑪ Asymmetrical interrupting capability = "S" times symmetrical interrupting capability, both at specified operating voltage.
- ⑫ ANSI standard requires 150 kV BIL. All 38 kV ratings are tested to 170 kV BIL.
- ⑬ Type 380 VCP-2 40 circuit breaker is not rated for rapid reclosing.

Extra Capability Type VCP-WC Ratings (Symmetrical Current Basis)

	Circuit Breaker Type				
	50 VCP-W 25C	50 VCP-W 40C	50 VCP-W 50C	50 VCP-W 63C	75 VCP-W 50C
Rated Values					
Voltage					
Maximum voltage V kV rms	5.95	5.95	5.95	5.95	10.3
Voltage range factor K	1	1	1	1	1
Insulation level—withstanding					
Power frequency (1 min.) kA rms total	24	24	24	24	42
Lighting impulse 1.2 x 50 μ s kV peak	75	75	75	75	95
Continuous current at 60 Hz A rms	1200	1200	1200	1200	1200
	2000	2000	2000	2000	2000
	3000 ^④	3000 ^④	3000 ^④	3000 ^④	3000 ^④
Short-circuit current					
Sym. interrupting at voltage (I _{sc}) kA rms total	25	40	50	63	50
% DC component (I _{dc})	50	75	57	62	57
	75	—	57	—	57
	75	—	52	—	52
Asym. interrupting (I _l) kA rms	31	58	64	83	64
	36	—	64	—	64
	36	—	62	—	62
Closing and latching capability kA peak	97	139	139	175	139
Short-time current for 3 seconds kA rms ^①	25	40	50	63	50
Interrupting time ms ^②	50	50	50	50	50
Maximum permissible tripping delay sec.	2.0	2.0	2.0	2.0	2.0
Rate of rise of recovery voltage (RRRV) kV/ μ s ^③	0.9	0.9	0.9	1.1	0.9
	0.9	0.9	0.9	—	0.9
	0.8	0.8	0.8	—	0.8
Capacitor switching ratings					
General purpose—isolated shunt capacitor bank current A rms	400 and 630	630 ^⑤	630 ^⑤	250	630 ^⑤
	1000 ^⑤	1000 ^⑤	1000 ^⑤	—	1000 ^⑤
	250	250	250	—	250
Definite purpose—back-to-back capacitor switching					
Capacitor bank current A rms	400 and 630	630 ^⑥	630 ^⑥	200, 1600 ^⑦	630 ^⑥
	1000 ^⑥	1000 ^⑥	1000 ^⑥	200, 1600 ^⑦	1000 ^⑥
	—	—	—	200, 1600 ^⑦	—
Inrush current kA peak	20 and 20	15	15	7.7	15
	18	18	18	7.7	18
	—	—	—	7.7	—
Inrush frequency kHz	6.5 and 5.5	3.5	3.5	465	3.5
	2.7	2.7	2.7	465	2.7
	—	—	—	465	—
Mechanical Endurance—No-Load Operations	10,000	10,000	10,000	10,000	10,000
	10,000	10,000	10,000	10,000	10,000
	5000	5000	5000	5000	5000

Notes

① Except as noted.

② Three cycles.

③ Contact Eaton for higher RRRV or for more information.

④ 4000A FC rating available.

⑤ Breaker tested to 2700A single bank switching for momentary load (thermal de-rating must consider harmonic content of current waveform).

⑥ Breaker tested to 1270A back-to-back switching for momentary load (thermal de-rating must consider harmonic content of current waveform).

⑦ C37.04.a-2003 Class C2 at 15 kV.

38 kV, 2500A and 3000A WC breakers are not rated for rapid reclosing.

Extra Capability Type VCP-WC Ratings (Symmetrical Current Basis), continued

Rated Values	Circuit Breaker Type				
	150 VCP-W 25C	150 VCP-W 40C	150 VCP-W 50C	150 VCP-W 63C	270 VCP-W 25C
Voltage					
Maximum voltage V kV rms	17.5	17.5	17.5	15	27
Voltage range factor K	1	1	1	1	1
Insulation level—withstanding test					
Power frequency (1 min.) kA rms total	42	42	42	42	60
Lighting impulse 1.2 x 50 μ s kV peak	95	96	95	95	125
Continuous current at 60 Hz A rms					
	1200	1200	1200	1200	1200
	2000	2000	2000	2000	1600
	3000 ^④	3000 ^④	3000 ^④	3000 ^④	—
Short-circuit current					
Sym. interrupting at voltage (Isc) kA rms total	25	40	50	63	25
% DC component (Idc)					
	50	75	57	62	75
	75	—	57	—	—
	75	—	52	—	—
Asym. interrupting (I_l) kA rms					
	31	58	64	83	36
	36	—	64	—	—
	36	—	62	—	—
Closing and latching capability kA peak	97 ^⑤	139	139	175	85
Short-time current for 3 seconds kA rms ^①	25	40	50	63	25 ^⑥
Interrupting time ms ^②	50	50	50	50	50
Maximum permissible tripping delay sec.	2.0	2.0	2.0	2.0	2.0
Rate of rise of recovery voltage (RRRV) kV/μs^③					
	0.9	0.9	0.9	1.1	1.1
	0.9	0.9	0.9	—	—
	0.8	0.8	0.8	—	—
Capacitor switching ratings					
General purpose—isolated shunt capacitor bank current A rms					
	400A and 630 ^⑦	630 ^{⑦⑧}	630 ^{⑦⑧}	250	400
	1000 ^{⑦⑧}	1000 ^{⑦⑧}	1000 ^{⑦⑧}	—	—
	250 ^⑦	250 ^⑦	250 ^⑦	—	—
Definite purpose—back-to-back capacitor switching					
Capacitor bank current A rms					
	400 and 600 ^⑦	630 ^{⑦⑧}	630 ^{⑦⑧}	200, 1600 ^⑨	400
	1000 ^{⑦⑧}	1000 ^{⑦⑧}	1000 ^{⑦⑧}	200, 1600 ^⑨	—
	—	—	—	200, 1600 ^⑨	—
Inrush current kA peak					
	20 and 20	15	15	7.7	20
	18	18	18	7.7	—
	—	—	—	7.7	—
Inrush frequency kHz					
	6.5 and 5.5	3.5	3.5	465	4.2
	2.7	2.7	2.7	465	—
	—	—	—	465	—
Mechanical Endurance—No-Load Operations					
	10,000	10,000	10,000	10,000	5000
	10,000	10,000	10,000	10,000	—
	5000	5000	5000	5000	—

Notes

- ① Except as noted.
 - ② Three cycles.
 - ③ Contact Eaton for higher RRRV or for more information.
 - ④ 4000A FC rating available.
 - ⑤ Close and latch current for 1200A Type 150 VCP-W 25C is proven at 15 kV. For sealed interrupters at high altitudes, switching voltage is not de-rated.
 - ⑥ 2.5 seconds.
 - ⑦ Capacitor switching ratings are proven at 15 kV. For sealed interrupters at high altitudes, switching voltage is not de-rated.
 - ⑧ Breaker tested to 2700A single bank switching for momentary load (thermal de-rating must consider harmonic content of current waveform).
 - ⑨ Breaker tested to 1270A back-to-back switching for momentary load (thermal de-rating must consider harmonic content of current waveform).
 - ⑩ C37.04.a-2003 Class C2 at 15 kV.
- 38 kV, 2500A and 3000A WC breakers are not rated for rapid reclosing.

Extra Capability Type VCP-WC Ratings (Symmetrical Current Basis), continued

Rated Values	Circuit Breaker Type					
	270 VCP-W 32C	270 VCP-W 40C	380 VCP-W 16C	380 VCP-W 25C	380 VCP-W 32C	380 VCP-W 40C
Voltage						
Maximum voltage V kV rms	27	27	38	38	38	38
Voltage range factor K	1	1	1	1	1	1
Insulation level—withstanding test						
Power frequency (1 min.) kA rms total	60	60	80	80	80	80
Lighting impulse 1.2 x 50 μ s kV peak	125	125	170	170	170	170
Continuous current at 60 Hz A rms	1200	1200	600	600	600	1200
	1600	1600	1200	1200	1200	2000
	—	—	1600	1600	1600	2500
	—	—	2000	2000	2000	3000FC ^④
	—	—	—	—	2500	—
	—	—	—	—	3000FC ^⑤	—
Short-circuit current						
Sym. interrupting at voltage (I _{sc}) kA rms total	31.5	40	16	25	33.1	40
% DC component (I _{dc})	55	50	75	65	57	63
Asym. interrupting (I _h) kA rms	40	49	23.3	34.0	42.5	53.5
Closing and latching capability kA peak	100	112	50	75	91	107
Short-time current for 3 seconds kA rms ^①	31.5 ^⑥	40 ^⑦	16	25	31.5 ^⑥	40
Interrupting time rms ^②	50	50	50	50	50	50
Maximum permissible tripping delay sec.	2.0	2.0	2.0	2.0	2.0	2.0
Rate of rise of recovery voltage (RRRV) kV/ μ s ^③	1.1	1.1	0.7	0.7	0.7	0.7
	—	—	0.7	0.7	0.7	—
	—	—	1.3	1.3	0.7	—
	—	—	—	—	1.3	—
	—	—	—	—	0.7	—
	—	—	—	—	1.3	—

Notes

① Except as noted.

② Three cycles.

③ Contact Eaton for higher RRRV or for more information.

④ 2500A FC to 3000A.

⑤ 2000A FC to 3000A.

⑥ 1.6 seconds.

⑦ 1 second.

⑧ 2.5 seconds.

38 kV, 2500A and 3000A WC breakers are not rated for rapid reclosing.

Extra Capability Type VCP-WC Ratings (Symmetrical Current Basis), continued

	Circuit Breaker Type					
	270 VCP-W 32C	270 VCP-W 40C	380 VCP-W 16C	380 VCP-W 25C	380 VCP-W 32C	380 VCP-W 40C
Rated Values, continued						
Capacitor switching ratings						
General purpose—isolated shunt capacitor bank current A rms	400	400	250	250	250	—
	—	—	250	250	250	—
	—	—	250	250	250	—
	—	—	250 and 1000	250 and 1000	250 and 1000	—
	—	—	—	—	—	—
	—	—	—	—	250 and 1000	—
Definite purpose—back-to-back capacitor switching						
Capacitor bank current A rms	400	400	250	250	250	—
	—	—	250	250	250	—
	—	—	250	250	250	—
	—	—	250 and 1000	250 and 1000	250 and 1000	—
	—	—	—	—	—	—
	—	—	—	—	250 and 1000	—
Inrush current kA peak						
	20	20	20	20	20	—
	—	—	20	20	20	—
	—	—	20 and 20	20 and 20	20 and 20	—
	—	—	—	—	—	—
	—	—	—	—	20 and 20	—
Inrush frequency kHz						
	4.2	4.2	4.4	4.4	4.4	—
	—	—	4.4	4.4	4.4	—
	—	—	4.4	4.4	4.4	—
	—	—	5 and 5	5 and 5	5 and 5	—
	—	—	—	—	—	—
	—	—	—	—	5 and 5	—
Mechanical Endurance—No-Load Operations	5000	5000	10,000	10,000	10,000	10,000

Note

38 kV, 2500A and 3000A WC breakers are not rated for rapid reclosing.

C-HRG Free-Standing NEMA 1 Unit



7

Product Description

Where continuity of service is a high priority, high resistance grounding can add the safety of a grounded system while minimizing the risk of service interruptions due to grounds. The concept is a simple one: provide a path for ground current via a grounding transformer (with adjustable resistance across its secondary) that limits the current magnitude and a monitor to determine when an abnormal condition exists.

The ground current path is provided at the point where the service begins, by placing a predominantly resistive impedance in the connection from system neutral to ground. Control equipment continuously measures ground current; a relay detects when the current exceeds a predetermined level. An alarm alerts building personnel that a ground exists. The system has built-in fault tracing means to assist in finding the source of the ground. A 120 Vac supply (remote) is required for control power for the system.

Application Description

This member of Eaton's MV metal-clad switchgear family has actually been around for many years. The free-standing C-HRG provides a standalone unit that can be added to existing installations. The C-HRG is used to protect an electrical distribution system from damaging transient overvoltages caused by ground faults. It also provides a means to locate the ground fault, therefore extending the life of the distribution system.

Ratings and Configurations

The C-HRG MV is offered at the 5 kV class rating. It can be applied to delta or wye ungrouped three-wire distribution systems.

Contents

Description

	<i>Page</i>
High Resistance Grounding System	
Features, Benefits and Functions	V3-T7-21
Standards and Certifications	V3-T7-21
Catalog Number Selection	V3-T7-22
Technical Data and Specifications	V3-T7-23
Dimensions	V3-T7-26

4200V (Maximum) Delta Systems

To add high resistance grounding to an ungrounded delta-connected system, a neutral point must be created. Three single-phase transformers can be interconnected in a wye-broken delta configuration to provide such a neutral point. The transformers and grounding resistors are chosen to limit the ground current to a maximum value of 6A.

Note: The neutral point may not be used to serve phase-to-neutral loads. Also, this technique may be applied on wye-connected sources when the neutral point is not conveniently accessible from the service entrance location. This method is shown in the illustration shown on **Page V3-T7-24**. One delta high resistance grounding would ground the 5 kV system.

4200V (Maximum) Wye Systems

To add high resistance grounding to a wye-connected system, resistors are placed across the secondary of a grounding transformer whose primary is placed in series with the neutral-to-ground connection of the power source. The resistors are chosen to limit the current to a maximum value of 6A.

Note: Per 1993 NEC® 250.5b, exception No. 5, line-to-neutral loads may not be connected to a system in which the neutral is resistance grounded. Also, if the system has two switchable sources not permanently connected to the bus, two wye-type grounding systems are required as shown on **Page V3-T7-24**.

Ground Current Detection

Any time a system is energized, a small ground current called the “capacitive charging current” will be observed. For medium voltage (4200V and below) systems, this naturally occurring current is typically 3A or less.

When one phase becomes grounded, additional current above the charging level will flow. As all ground current must flow through the grounding resistor/grounding transformer assembly, an ammeter in this circuit will read the total amount of ground current. By placing a current-sensing relay in series with the ammeter, the current relay can be adjusted to pick up at a level in excess of the capacitive charging current, thus indicating the abnormal condition.

Alternatively, an optional voltmeter-relay can be connected across the grounding resistors. The voltage across the resistors is proportional to the amount of ground current. The voltmeter-relay’s pickup adjustment is set above the capacitive charging current, to the desired detection level.

In both current and voltage detection methods, the ground current ammeter provides a direct reading of the total actual ground current present in the system at that time. It will be helpful to periodically note the ammeter’s reading: a trend toward higher values may indicate the need for equipment maintenance, and hence reduce the occurrence of unplanned shutdowns.

Indication and Alarm Circuits

When a fault is detected, an adjustable time delay is provided to override transients. When the time delay has been exceeded, the green “normal” light will turn off, the red “ground fault” light will turn on, and the ground alarm contacts will transfer. If equipped with the optional alarm horn, it will sound.

The grounding transformer secondary breaker must be closed for the system to be operational. Should this breaker be opened at any time, the system will signal a ground fault condition as a fail-safe feature. The breaker must be closed to clear the alarm signal.

When the fault is cleared, the current/voltage relay will reset. If the reset control is set on “auto,” the lights will return to “normal” on, “ground fault” off, and the ground alarm contacts will re-transfer. If the reset control is set on “manual,” the lights and relay contacts will remain latched until the operator turns the reset control to “reset.” The lights and ground alarm contacts will then return to normal. The system can be reset only if the fault has been cleared.

During a fault, the optional alarm horn can be silenced at any time by using the “alarm silence” pushbutton. It will not re-sound until either the system is reset, or the re-alarm timer expires. The re-alarm timer is activated by the “alarm silence” control. If the horn has been silenced but the fault has not been cleared, the timer will run. It has a range of 2–48 hours. When the timer times out, the horn will re-sound, alerting maintenance personnel that the fault has not been cleared.

Test Circuit

A test circuit is provided to allow the user to quickly determine that the system is working properly. The test circuit will operate only under normal conditions—it will not allow testing if the system is sensing a fault. The test operation does not simulate an actual system ground fault. It does, however, test the complete controls of the fault indication and pulsing circuitry. The system then reacts as it would under actual system ground conditions—lights transfer, alarm contacts transfer and the (optional) horn sounds.

Pulser Circuit

The pulser circuit offers a convenient means to locate the faulted feeder and trace the fault to its origin. The pulser is available any time a fault has been detected. The pulse intervals are controlled by an adjustable recycle timer. The “pulse” light flashes on and off, corresponding to the on-off cycles of the pulser contactor. The pulser contactor switches a bank of resistors on and off, thus allowing a momentary increase in the ground current (approximately a 4A current pulse above the ground current).

Locating a Ground Fault

The current pulses can be noted with a clamp-on ammeter when the ammeter is placed around the cables or conduit feeding the fault. The operator tests each conduit or set of cables until the pulsing current is noted. By moving the ammeter along the conduit, or checking the conduit periodically along its length, the fault can be traced to its origin. The fault may be located at the point where the pulsing current drops off or stops.

If little or no change in the pulsing current is noted along the entire length of a conduit, then the fault may be in the connected load. If the load is a panelboard, distribution switchboard or motor control center, repeat the process of checking all outgoing cable groups and conduits to find the faulted feeder. If the fault is not found in an outgoing feeder, the fault may be internal to that equipment.

Note: It may not be possible to precisely locate faults within a conduit. The ground current may divide into many components, depending on the number of cables per phase, number of conduits per feeder, and the number and resistance of each ground point along the conduits. The resulting currents may be too small to allow detection or may take a path that the ammeter cannot trace. An important note to keep in mind is that while the pulser can greatly aid in locating a fault, there may be certain conditions under which the pulses cannot be readily traced, and other test procedures (megohm, high-potential, etc.) may be needed.

Sequence of Operations**Normal**

- Green “normal” light on
- Red “ground fault” light off
- White “pulse” light off
- System control switch in “normal” position
- Reset control switch in either “auto” or “manual”

Test

Turn and hold the system control switch in the “test” position. This mode will test the control circuitry only. It will bypass the sensing circuit and cause the green “normal” light to turn off and the red “ground fault” light to turn on. The pulser will be activated as well. The white “pulse” light will turn on and off as the pulser contactor closes and opens. However, the ground current ammeter will not display the total ground current, including the incremental pulse current. When ready, return the system control switch to “normal.” The pulser will stop. If the reset control is in the “manual” position, turn it to “reset” to reset the fault sensing circuit. The red “ground fault” light will turn off, and the green “normal” light will turn on. Test mode is not available if the system is detecting a ground. The sensing circuit will disable the test circuit.

Ground Fault

When the sensing circuit detects a fault, the green “normal” light will turn off and the red “ground fault” light will turn on. The ground current ammeter will indicate the total ground current. To use the pulser, turn the system control switch to “pulse.” The pulser contactor will cycle on and off as controlled by the recycle timer relay. Use the clamp-on ammeter to locate the faulted feeder. Open the feeder and clear the fault. If the reset control switch is in the “manual” position, turn it to “reset” to reset the sensing circuit. (If reset control is in “auto,” it will reset itself.) When ready to restore service to the load, close the feeder. Return the system control to “normal.”

Features, Benefits and Functions

When a ground fault occurs on an ungrounded system, high transient voltages can occur, which may cause more frequent equipment failures than if the equipment were grounded. These transient overvoltages, as high as four times the normal voltage, reduce the life of the system's insulation resulting in:

- Motor failure
- Transformer failure
- Coil failure
- Electronic equipment failure
- Cable insulation failure

By using a high resistance ground system, many facilities can gain the benefit of a grounded system without impairing the continuity of service to their equipment. The concept behind high resistance grounding is to provide a path for the ground current to flow while limiting its magnitude by using a resistor. The ground current path is provided at the point where service begins. Control equipment continuously monitors the magnitude of the ground current.

When the ground current exceeds a predetermined level, the built-in alarm relay alerts building personnel that a ground fault exists. In addition, the C-HRG MV "safe ground" system has a built-in fault pulsing as a means to assist in finding the source of the ground fault without interrupting service.

- Current sensing ground fault detection (2–10A pickup/ 0.5–20 second delay)
- Ground current transformer (10/10 ratio)
- Control circuit pull fuseblock
- Ground current ammeter (0–10A, 1% accuracy)
- Indicating lights:
 - Red (ground fault)
 - Green (normal)
 - White (pulse)
- Adjustable pulsing timer (0–10 seconds)
- Tapped resistors (limits primary current to 3–6A)
- Three-position selector switch (normal, pulse, test)
- Control switch for manual or automatic reset
- Ground fault contacts (1NO/1NC)
- Shorting terminal block for ground current CT
- UL label
- Wiremarkers

Standards and Certifications

The system shall be completely assembled, wired and tested at the factory in accordance with NEMA and UL requirements. A certified production test report shall be shipped with the unit.



7.3

Medium Voltage Switchgear

High Resistance Grounding System

Catalog Number Selection

A C-HRG High Resistance Grounding Assembly can be completely described by an 8-digit catalog number: MVRG-_____

High Resistance Grounding Systems

MVRG F X D D N L T S

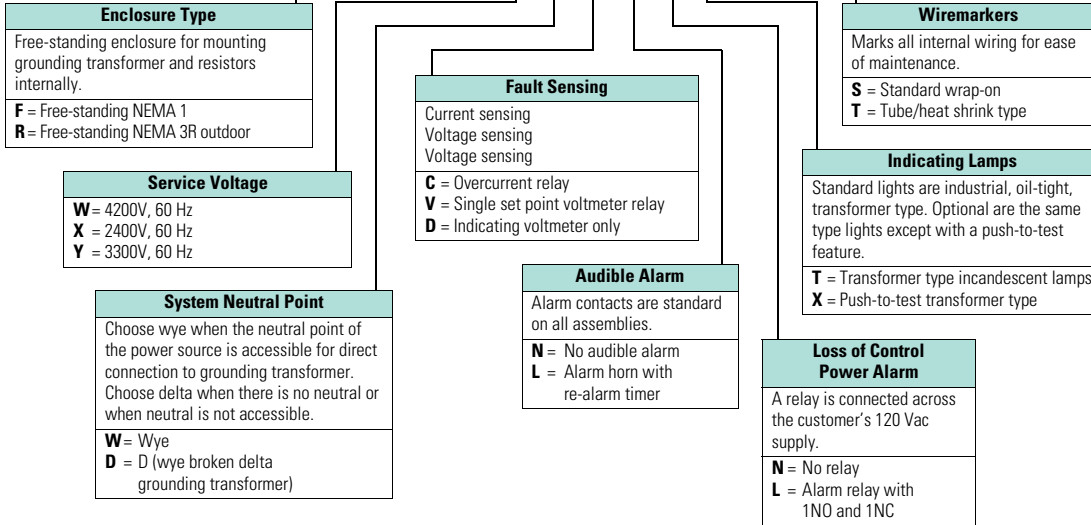

Example: MVRG-FWWCLLTS defines a free-standing NEMA 1 enclosure, 4200V/60 Hz, wye-connected system, current-sensing control scheme, alarm horn with re-alarm timer, alarm relay with 1NO and 1NC, transformer type incandescent lights, wrap-on wiremarkers.

Technical Data and Specifications

General

Provide a high resistance grounding system as a means to provide a path for ground current via a resistance that limits the current magnitude. While monitoring the ground current, the system must be able to determine when an abnormal condition exists. Once the abnormality is detected, the system shall alert building personnel that a ground exists. The system shall be suitable for 5000V maximum service, and designed and tested for that voltage class in accordance with the latest standards of NEMA and UL.

- Tapped resistors supply primary ground current between 3 and 6A in 1A increments
- Pulse current is an additional 4A. (pulse currents of a lower magnitude may be difficult to detect)
- Pulse timer is adjustable from 3 to 60 pulses per minute
- Time delay for current sensing relay is 0.5 to 20 seconds with a 2 to 10A pickup. Time delay for voltage sensing relay is 1 to 60 seconds
- "Pull-type" fuse disconnects are supplied for control equipment protection
- All exterior nameplates are fastened with stainless steel screws
- Nameplates are 2-ply with 3/16-inch (4.8 mm) lettering. The nameplate size is 1-inch (25.4 mm) x 2-1/2-inch (63.5 mm). White background with black lettering is standard
- Top and bottom cable entry areas
- Phase and neutral terminals accept #4 AWG to 500 kcmil
- Ground terminal accepts wire sizes from #4 AWG to 500 kcmil. Ground bus is 1/4-inch (6.35 mm) x 2-inch (50.8 mm) copper
- The powder paint is applied to the parts electrostatically. Metal surfaces are prepared by spray cleaning and phosphatizing. The powder paint is a polyester urethane. The standard color is ANSI 61, light gray. The paint is applied to a thickness of 1.5 mil
- Appropriate current limit drawout type fuses are provided. The chassis is mechanically interlocked with a secondary circuit breaker to prevent its withdrawal under load conditions
- Resistors are grid type to provide the maximum area for heat dissipation
- No. 4 AWG wire is used for internal connections from the neutral point to ground. Control connections are a minimum of #14 gauge. All control wires insulation is type SIS
- Recommended spare parts list
- Steel pocket on the inside of the door is provided to hold drawings and manuals

Note: The C-HRG units can be applied on any three-wire distribution system, regardless of the manufacturer of the distribution equipment or source power transformer.

System Ratings and Features

Provide a UL-labeled high-resistance grounding system equal to Eaton catalog number _____ for use on a system with a short-circuit capacity of ___kA at ___ volts. The structure shall be a [free-standing NEMA 1] [free-standing NEMA 3R]. The system neutral point shall be provided by [the power transformer's wye neutral point] [wye-broken delta grounding transformers]. The ground current shall be detected with [an overcurrent relay] [a single set point voltmeter relay]. [An alarm horn with re-alarm timer is required.] [An alarm to indicate the loss of control power is required.] The indicating lights shall be [transformer-type incandescent lamps] [push-to-test transformer type lamps]. Control wiring shall be marked using [wrap-on type] [heat-shrink sleeve type] wiremarkers. [A portable clamp on detector with 1/2/5/10/20A scales, a shorting switch and a storage case is required].

In addition to the components specified, the following shall be supplied with each system:

- Ground current transformer (10/10 ratio)
- Control circuit disconnect switch (fused)
- Ground current ammeter (0–10A, 1% accuracy)
- Control switch for manual or automatic reset
- Ground fault contacts (1NO/1NC) for customer use
- Shorting terminal block for ground current CT
- Adjustable pulsing timer (0–10 seconds)
- Tapped resistors (across neutral forming transformer secondary, limiting primary current to 3–6A)
- Three-position selector switch (normal, pulse, test)
- Indicating lights:
Red (ground fault)
Green (normal)
White (pulse)

Components and Connections

Phase and neutral terminals shall accept #4 AWG to 500 kcmil wire. Ground terminals shall accept wire sizes from #8 AWG to 500 kcmil. Ground bus shall be 1/4-inch (6.35 mm) x 2-inch (50.8 mm) copper. #4 AWG wire shall be used for all internal connections from the neutral point to ground. Control connections shall be a minimum of #14 gauge. All control wire insulation shall be type SIS. All control wiring shall be labeled at each end. Wiring within the resistor assembly shall be rated for 200°C service.

Structure

The unit shall be free-standing and house the resistor bank within an isolated section of the structure. Access to the resistor shall be via a bolted-on cover. The rear cover shall be removable. The structure shall provide top and bottom cable entry points. Lifting angles shall be provided to facilitate the installation of the unit. The structure shall be suitable for moving on rollers and shall be skidded for shipment in a manner suitable for handling by a forklift.

All steel parts (except for plated parts) shall be thoroughly cleaned and phosphatized prior to the application of the light gray ANSI No. 61 finish. A pocket is required on the inside of the control compartment door to store drawings and manuals.

7.3

Medium Voltage Switchgear

High Resistance Grounding System

Wiring Diagram

HRG—High Resistance Grounding System

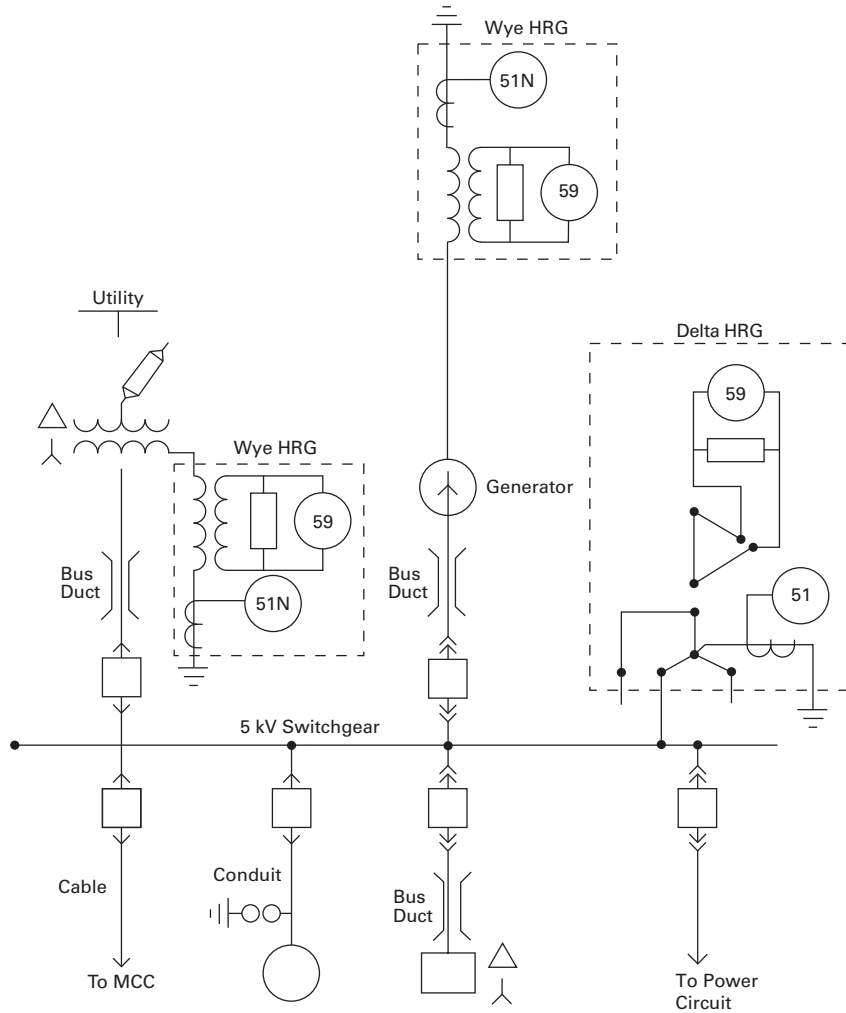

Circuit Diagrams

Ungrounded Wye System (with standard current and optional voltage relay fault detectors)

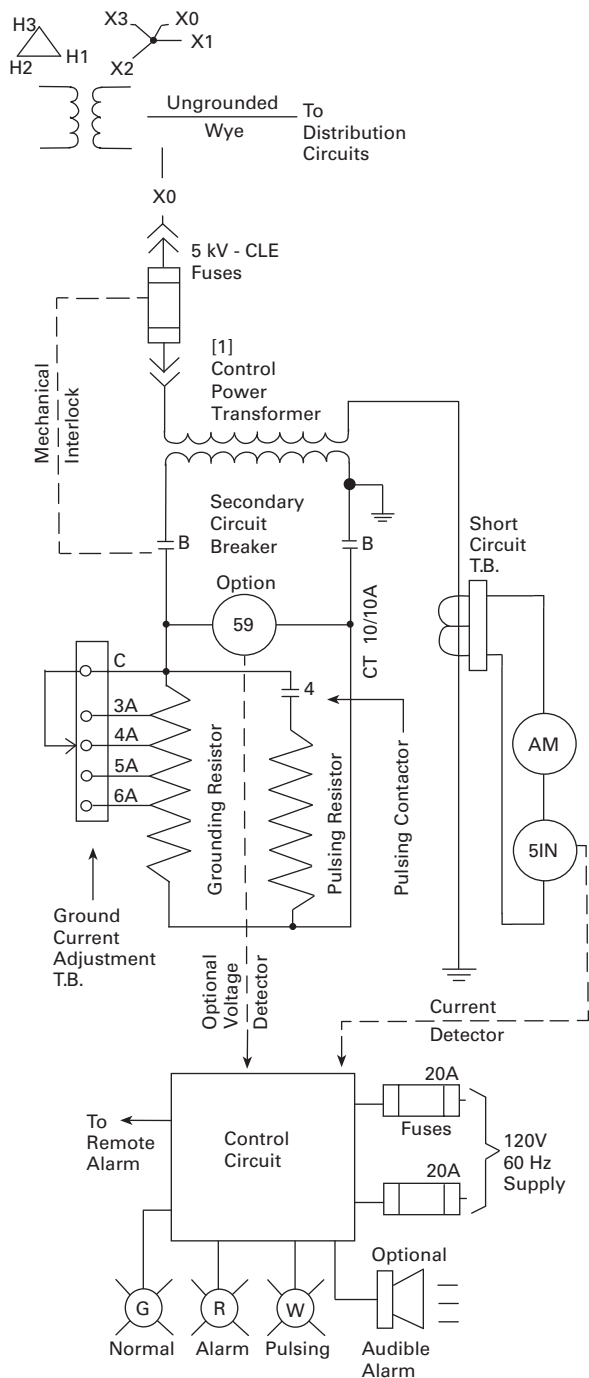

Ungrounded Delta System (with standard current and optional voltage relay fault detectors)

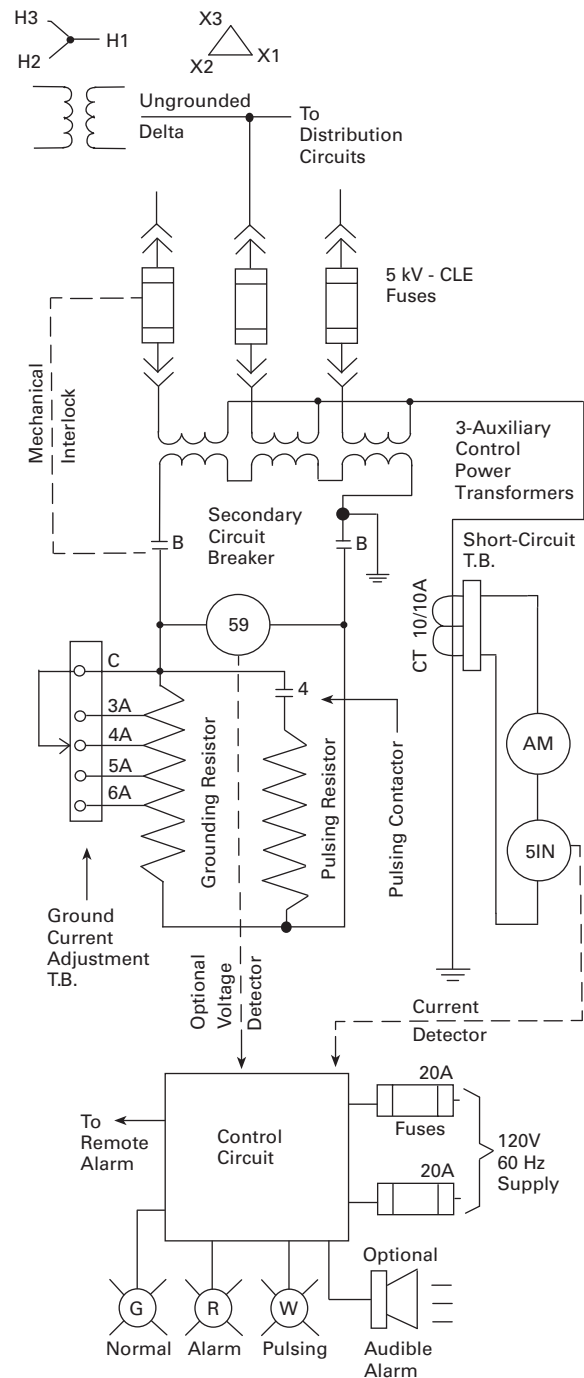

7.3

Medium Voltage Switchgear

High Resistance Grounding System

Dimensions

Approximate Dimensions in Inches (mm)

NEMA 1 Free-Standing

7

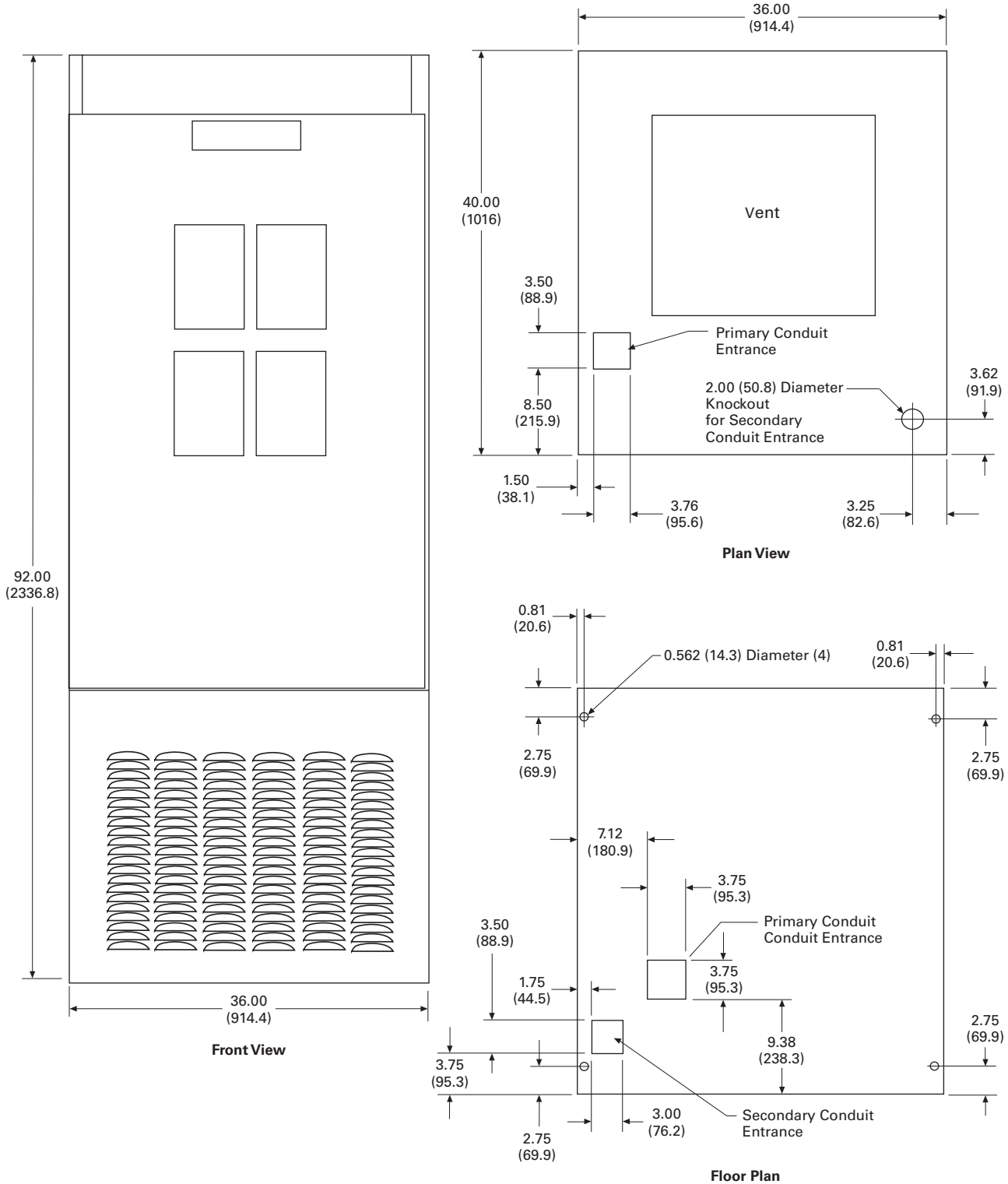

CM52 Network Protector



8.1	Drawout Air Circuit Breaker Design	
	Network Protectors—CM52	V3-T8-2
	Product Description	V3-T8-2
	Application Description	V3-T8-2
	Features, Benefits and Functions	V3-T8-2
	Standards and Certifications	V3-T8-3
	Technical Data and Specifications	V3-T8-3
8.2	Network Relay	
	Network Relay—MPCV	V3-T8-4
	Product Description	V3-T8-4
	Application Description	V3-T8-4
	Features, Benefits and Functions	V3-T8-4
8.3	Network Protector Aftermarket	
	Network Protector Rebuild and Parts Program	V3-T8-5
	Parts	V3-T8-5
	Rebuild Services	V3-T8-5
	Quick Ship	V3-T8-5

CM52 Network Protector



Network Protectors—CM52

Product Description

Network protectors are special self-contained air power breaker units having a full complement of current, potential and control transformers, as well as relay functions to protect the integrity of the low voltage network bus. The network protector can be in NEMA® housing, submersible housing, or suitable for mounting within a low voltage switchgear assembly. Several network protector models exist including the CM52, CMD and CM-22. The most recent model, the CM52 network protector, is highlighted in the following paragraphs.

Application Description

Network protectors are mainly used by utilities around the world. They are configured in either a spot or grid network. Most installations of network protectors are in underground vaults and require a submersible enclosure. Commercial applications also exist for customers that require highly reliable, stable power. These applications typically use a NEMA enclosure and are configured in a spot network. Some examples of commercial users are government buildings, hospitals, universities and industrial plants.

Contents

Description

Network Protectors—CM52

Standards and Certifications	V3-T8-3
Technical Data and Specifications	V3-T8-3

Page

Features, Benefits and Functions

Eaton's Type CM52 is designed for improved safety, higher quality, ease of maintenance and inventory reduction.

or submersible enclosures, completely cover the needs of the network protector industry

- Deadfront 4-position drawout breaker helps protect the user from accidental contact with live circuits and makes maintenance and troubleshooting easier

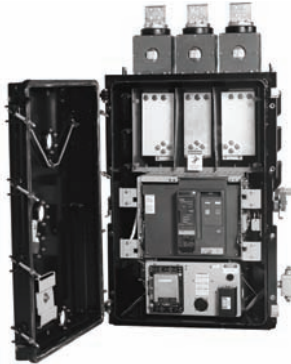

CM52—Highlight of Relay Module

- Standardized breaker elements throughout entire electrical ratings allow for the use of common parts and accessories
- Smaller breaker element is less than half the weight of existing network designs
- The CM52 is the first network protector to pass 10 kV BIL, giving an additional measure of safety and performance
- Ratings of 800–6200A, 216–600V, internal or external fuses and NEMA



Deadfront, Drawout Breaker

- More diagnostics through the Indicating Diagnostic Module (IDM)



Indicating Diagnostic Module (IDM)

- Front-mounted test points give easy access and quick test cable connection
- Color-coded Teflon® wiring for easier troubleshooting

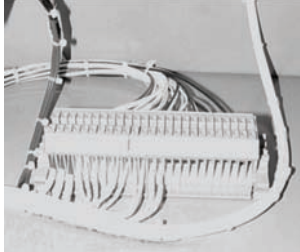

Color-Coded Wiring

- The CM52 breakers are all wired the same regardless of system voltage (216V, 480V and 600V)
- 3NO and 3NC dry contacts are standard as spare

Options

Arc Flash



VaultGuard™ Arcflash Reduction Maintenance System™ Indicating Diagnostic Module

The CM52 Network Protector is available with the NPARMs module (Arcflash Reduction Maintenance System).

This device is internal to the Network Protector and can be remotely activated usually through a switch mounted at the vault entrance or through communications. This will enable the “ARMS” device on all CM52s in a spot network. Once activated, the NPARMs places the protectors in a sensitive mode, sensing both forward and reverse current directions. This device will actuate in 3–4 ms and call for all CM52 breakers to trip if a fault is sensed on an adjacent network protector or collector bus. It has been shown that this device limits the total incident energy to less than 8 cal/cm².

Remote Racking System

The CM52 Network Protector is also available with an integral remote racking system. The system remotely racks the breaker off the

energized bus work while the door is still closed to the “test” position either through an external pendant or through communications.



Remote Racking System

Standards and Certifications

- Meets or exceeds the standards in IEEE® C57.12.44
- The CM52 Network Protector is UL labeled and approved in the NEMA housing at all ratings



Technical Data and Specifications

CM52 Ratings Comparison Table—Ratings Tested at 600V

Continuous Current Rating (Amperes)	Breaker Element Width in Inches (mm)	CM52 Interrupting Rating (kA)	CM52 Close and Latch Rating (kA)	IEEE/ANSI Interrupting Rating (kA)	IEEE/ANSI ① Close and Latch Rating (kA)
800	17.00 (431.8)	42	35	30	25
1200	17.00 (431.8)	42	35	30	25
1600/1875	17.00 (431.8)	42	35	30	25
2000	17.00 (431.8)	42	35	35	35
2500/2825	22.00 (558.8)	65	45	60	40
3000	22.00 (558.8)	65	45	60	40
3500	35.00 (889.0)	85	65	60	40
4500	35.00 (889.0)	85	65	60	40
6200 ②	35.00 (889.0)	85	65	Product not defined	Product not defined

Notes

- ① Close and latch ratings apply only to spring close and stored energy mechanisms. The CM22 does not have a close and latch rating.
 ② Open frame only, tested at 500V.

MPCV Communications Relay



8

Contents

Description

Network Relay—MPCV

Network Relay—MPCV

Product Description

Type MPCV Network Protector Communications Relays for 216V and 480V Systems

- Eaton's programmable MPCV network relay brings the proven performance of microprocessor-based technology to new network protectors...or those already in service regardless of age or manufacturer
- The MPCV contains industry exclusive features such as:
 - Gull Wing Trip Characteristic
 - Remote Protective Close
 - Anti-Pumping Algorithm
- With the MPCV, you can select the characteristic curves to monitor and control the network protector through Eaton products such as the VaultGard, DNPMINT and NPView

Application Description

Factory or Field Installation

Eaton can factory mount MPCV relays on new network protectors...or personnel can easily field mount them on these existing network protectors:

- Eaton Types CM52, CMD, CM-22 or CMR-8
- General Electric® Types MG-8, MG-9 or MG-14

Field installation is accomplished without breaker modification or any rewiring of the breaker control harness. MPCV relays operate on 216V and 480V systems. Relay potential transformers are required for 480V applications.

Features, Benefits and Functions

Communications Capability

Each MPCV relay has the capability of communicating information and allowing control over a shielded twisted pair communications wire. Communications can be provided by a Web-enabled interface or direct DNP 3.0 to SCADA systems. Eaton has multiple choices for communication interfaces such as VaultGard for total vault communications, NPView- simple Web server or DNPMINT.

For localized access, the MPCV relay has the capability of wireless communication, monitoring and control with the Eaton wireless products.

- The MPCV is built for the harshest environments, with an operation temperature of -40°F (-40°C) up to 257°F (125°C). The MPCV is housed in a 0.25-inch (6.35 mm) thick solid cast brass can
- Access and display information from the MPCV such as: voltage, current, power, power factor, date and time stamped trip events, internal temperature and operations counter of breaker

- Through auxiliary inputs on the MPCV relay, operators can monitor other vault environment parameters such as transformer top oil temperature, water in the network vault, fire alarm or network enclosure pressure
- Event trending, threshold alarms and e-mail forwarding
- Multiple MPCVs can be connected together either as a daisy chain, T-configuration or a combination.



MPCV Communications Relay for Eaton Network Protectors



MPCV Communications Relay for General Electric Network Protectors

Rebuild Program



Contents

Description

Network Protector Rebuild and Parts Program

Network Protector Rebuild and Parts Program

Parts

- Renewal parts for all network protector models:
 - Eaton, Westinghouse®: CM-22, CMD, CM52 and CMR-8
 - General Electric: MG-8, MG-9 and MG-14
- 24-hour shipment when required for parts in stock

Rebuild Services

Eaton's Electrical Sector is setting the standard of reliability with a reconditioning process that involves total breaker and enclosure disassembly, material specific component cleaning, detailed inspection and state-of-the-art testing, all done to uniform documented specifications.

Eaton offers a CM52 retrofit breaker for legacy CMD and GE Network Protectors. The breaker can be installed in existing network protector enclosures without having to remove the enclosure from the vault or having to remove the secondary cable connections, saving both time and money.

Quick Ship

Eaton can build and ship brand new CM-22 or CMD network protectors in 4 to 6 weeks.

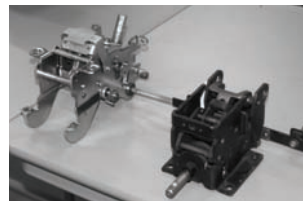

Retrobuild Before



Retrobuild After



Parts



Parts

Metering Devices, Protective Relays, Software and Connectivity

9.1	Power Xpert Architecture	
	Introduction	V3-T9-2
9.2	Monitoring Software and Reporting	
	Power Xpert® Software	V3-T9-14
9.3	Metering Devices	
	Product Overview	V3-T9-21
	Power Xpert Meter 4000/6000/8000 Series	V3-T9-30
	Power Xpert Meter 2000 Series	V3-T9-49
	IQ 250/260 Series Electronic Power Meters	V3-T9-60
	IQ 130/140/150 Series Electronic Power Meters	V3-T9-66
	IQ 150S/250S Self-Enclosed Electronic Meters	V3-T9-71
	IQ 35M	V3-T9-76
	IQ Analyzer 6400/6600 Series	V3-T9-79
	IQ DP-4000 Series	V3-T9-87
	IQ 230 Meters	V3-T9-93
	Power Xpert Multi-Point Meter	V3-T9-100
	IQ Energy Sentinel™	V3-T9-112
	PM3 Monitoring and Metering Module	V3-T9-121
	Current Transformers (CTs)	V3-T9-122
	Clamp-On Current Transformers	V3-T9-131
	IQ Flange	V3-T9-134
	Enclosed Meters	V3-T9-136
9.4	Protective Relays	
	Product Selection Guide	V3-T9-158
	FP-6000 Feeder Protection	V3-T9-162
	FP-5000 Feeder Protection	V3-T9-172
	FP-4000 Feeder Protection	V3-T9-180
	MP-3000 Motor Protection	V3-T9-188
	MP-4000 Motor Protection	V3-T9-198
	MD-3000 Motor/Generator Differential Relay	V3-T9-204
	Digitrip 3000	V3-T9-207
	VR-300 Multifunctional Voltage Relay	V3-T9-217
	DP-300 Current Differential Protection Relay	V3-T9-221
	EDR-3000 Feeder Protection	V3-T9-226
	ETR-4000 Transformer Protection Relay	V3-T9-237
	Ground Fault Relay	V3-T9-250
	Universal RTD Module	V3-T9-254
	IQ 125 Volt DC Power Supply	V3-T9-258
9.5	Connectivity Options	
	Power Xpert Gateways	V3-T9-259
	Power Xpert Ethernet Switches	V3-T9-272
	Power Xpert Gateway Series 1000 Card—Power Distribution Unit	V3-T9-276
	Power Xpert Gateway Series 2000 Card—Uninterruptible Power Supplies	V3-T9-279
	mMINT	V3-T9-282
	MINTII RS-232 Converter	V3-T9-284
	IPONI	V3-T9-285
	DPONI	V3-T9-286
	MPONI	V3-T9-287
	I/O Devices Digital Input Module (DIM)	V3-T9-288
	Addressable Relay II	V3-T9-290
	Breaker Interface Module II (BIM II)	V3-T9-293
	Sub-Network Master Local Display (SMLD)	V3-T9-297
	IMPCABLE	V3-T9-299

Power Xpert Architecture



Introduction

Enabling Power System Management

Eaton's Power Xpert Architecture (PXA) provides a complete hardware/software solution to manage your entire power system. Power Xpert Architecture consists of Power Xpert Meters, Gateways, Switches and Software.

Power Xpert devices are devices that can provide by themselves, or facilitate for others, Ethernet network protocols to communicate with your critical infrastructure components. Power Xpert devices provide the intelligent hardware connectivity layer to allow Web-enabled communications throughout the power system.

Power Xpert Meters

Power Xpert Meters provide measurement of the critical elements found in power systems, including voltage, power, current, transients, harmonics or even time. Power Xpert Meters provide Web-enabled communications for use through a Web browser or with the Power Xpert Software or third-party monitoring systems.

Power Xpert Gateways

Power Xpert Gateways are capable of Web-enabling electrical devices contained in electrical gear via a standard Web-browser on the Ethernet network. Standard on-board Web pages eliminate the need for any customer programming or software.

Power Xpert Software

Power Xpert Software is a comprehensive solution for system-level management of your power infrastructure via a Web-browser. Power Xpert Software provides a clear picture of what is happening at a component, device and system level.

Because no two organization's needs are the same, Power Xpert Software is available in two editions:

Contents

Description

	<i>Page</i>
Power Xpert System	V3-T9-3
Power Xpert Architecture	V3-T9-4
Level 0—Small System with Smart Hardware	V3-T9-8
Level 1—Using Power Xpert Gateways	V3-T9-9
Level 2—Power Xpert Software	V3-T9-11
Level 3—Eaton's Electrical Services & Systems (EESS) Customized Software Solutions	V3-T9-13



Support for Existing PowerNet Systems

Power Xpert is directly compatible with existing PowerNet™ systems v.3.32 and higher. All communications hardware devices such as NetLink, EMINT, MINT II and EPONI can be connected to Power Xpert Software through the PowerNet server for configuration of the INCOM™ communication devices.

Power Xpert Software Professional Edition

Geared toward end users, with built-in support for Eaton power distribution products such as switchgear, UPSs, breakers, PDUs, RPPs, meters, relays, VFDs and MCCs among others.

Eaton products connect with the software directly via an Ethernet connection, while legacy devices use a Power Xpert Gateway to Web-enable their communications.

A subset of third-party meters and devices are supported as standard via the gateway connection.

Power Xpert Software Enterprise Edition

Geared toward advanced power users, system integrators and enterprises with heterogeneous device spectrum and system developers who can take advantage of the included SNMP and Modbus® integration development utilities.

- Extensive support for third-party devices via standard SNMP and Modbus TCP protocols
- Large variety of ready made third-party drop in drivers

Power Xpert System

See Notes on **Page V3-T9-4**.

Power Xpert System Overview

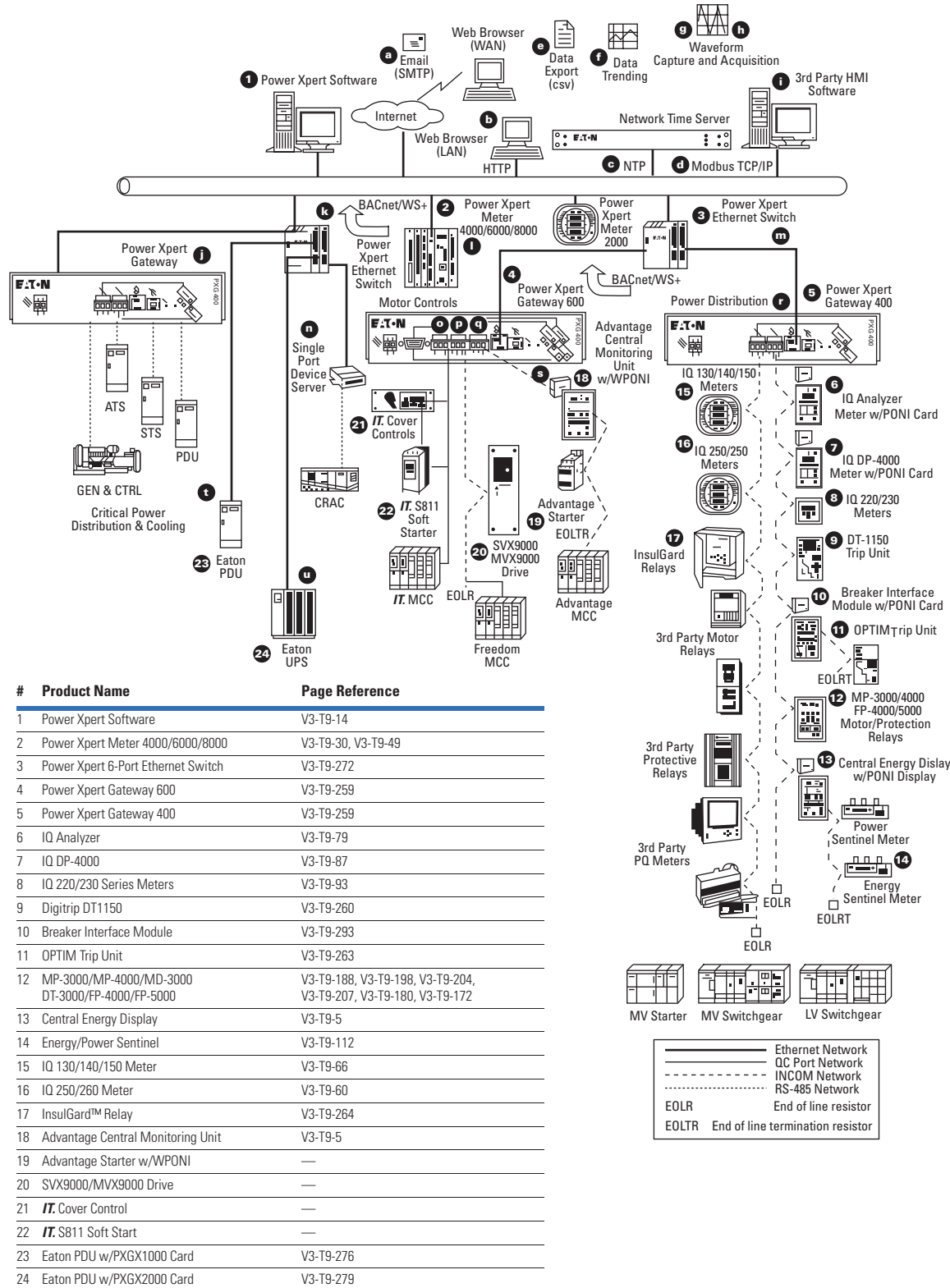

Power Xpert Architecture—Notes

- a. Simple Mail Transfer Protocol (SMTP)—Device events and periodic data log file attachments are sent to users in the form of an e-mail from the following Power Xpert products: Power Xpert Software, Power Xpert Meters 2000/4000/6000/8000, Power Xpert Gateway 600 and Power Xpert Gateway Cards 1000/2000 Series.
- b. Hyper Text Transfer Protocol (HTTP)—Web browser access is available on the following Power Xpert products: Power Xpert Software, Power Xpert Meters 2000/4000/6000/8000, Power Xpert Gateway 600 and Power Xpert Gateway Cards 1000/2000 Series.
- c. Network Time Server (NTP)—Network Time Protocol (Client-side) is available on the following Power Xpert products: Power Xpert Software, Power Xpert Meters 2000/4000/6000/8000, Power Xpert Gateway 600 and Power Xpert Gateway Cards 1000/2000 Series.
- d. Modbus TCP/IP—Modbus TCP/IP over Ethernet is available on the following Power Xpert products: Power Xpert Software, Power Xpert Server Core Software, Power Xpert Meters 2000/4000/6000/8000, Power Xpert Gateway 600 and Power Xpert Gateway Cards 1000/2000 Series. Modbus register maps are available online at www.eaton.com/powerxpert.
- e. Data Export—Data files consist of metered data and event log information that is exported from the meter, gateway or software in the form of a .csv (comma separated variable) file. Supported products are: Power Xpert Gateway PXG600, PXGX1000, PXGX2000, Power Xpert Meters 2000/4000/6000/8000 and Power Xpert Software.
- f. Data Trending—Viewing trended data in a standard Web browser interface in the form of a graphed line for one or more data points is available for the following products: Power Xpert Gateway PXG600, PXGX1000, PXGX2000, Power Xpert Meters 2000/4000/6000/8000 and Power Xpert Software.
- g. Waveform Capture—The ability to capture a waveform and/or export the waveform as a standard comtrade file format is available on the following products: Power Xpert Meters 4000/6000/8000.
- h. Waveform Acquisition and Export—The ability to acquire a waveform from another device that natively captures a waveform internally and then export that waveform in a standard comtrade file format is supported by the following devices: PXG600 (provides data acquisition and comtrade conversion for: IQ Analyzer, DT1150 and FP5000).
- i. Third-Party HMI Software Integration—Is achieved through the Modbus TCP/IP interface on all Power Xpert devices. If PowerNet software is utilized in the system, then an OPC Server is available.
- j. Proprietary Serial Device Protocols over Ethernet—The ability to communicate with third-party equipment is achieved through a Power Xpert Gateway via Modbus 485 or Modbus Serial.
- k. BACnet/WS+ —Is based upon the protocol specification developed by the ASHRAE standards group as an Addendum c to Standard 135-2004.

Reference: [BACnet—A Data Communication Protocol for Building Automation and Control Networks. Public Review Draft, ASHRAE Standard. BSR/ASHRAE Addendum c to ANSI/ASHRAE Standard 135-2004. First Public Review. Released: October 22, 2004. 32 pages. Copyright (c) American Society of Heating, Refrigerating and Air-Conditioning Engineers, Inc. August 30, 2004.]

This draft shows proposed changes to the current BACnet standard.

Note: Eaton has extended this protocol addendum with a (+) to signify the addition of an “event-driven” behavior to the existing “polled” data acquisition model. This allows optimization in communications between Power Xpert devices and Power Xpert Software.

Note: The Power Xpert Meters 4000/6000/8000 also export natively captured waveforms as comtrade file format.

- l. CEC (Communications Expansion Card PXMCE-B)—This card must be ordered as an option on the Power Xpert Meters 4000/6000/8000 to provide Ethernet connectivity for use with a Web browser, interface to Power Xpert Software or third-party HMI software.
- m. Ethernet Switch—The Eaton Ethernet Switch provides connectivity between Power Xpert devices on a common subnetwork. The 6-port version of the switch shown provides (6) RJ-45 network ports. As an option, 1 or 2 of these ports can be substituted to be ST-Type Fiber connections.
- n. Single-port Device Server—Is a device that is used to add network connectivity to a single serial device. These device servers offer a single RS-232/485 serial port to connect a variety of serial devices including meter devices, UPS, PDU, Static Switch, Automatic Transfer Switch, generators, Computer Room Air Conditioners, and other commercial, industrial or business automation equipment. The serial ports use standard RJ-45 or DB-9 connectors for convenient cabling, and optional adapters are available as well.
- o. PXG600A COM2 Port—Is used to communicate on a Modbus RS-232/485 network or on an Eaton QC-Port (IT) bus. The user may choose between a DB-9 or terminal strip connector to connect up to 32, RS-45 serial devices.
- p. PXG600A COM1 Port—Is used to communicate on a Modbus RS-232/485 network or on an Eaton QC-Port (IT) bus. A terminal strip connector is provided for this interface. Up to 32 devices may be connected to this port.
- q. PXG600A INCOM Port—Is used to communicate on an Eaton INCOM device network only. Up to 64 devices may be connected to this port.
- r. PXG400 Ports—The ports on the PXG400 operate the same as on the PXG600; however, there is only one RS-232/485 port to be used for Modbus or QC-Port.
- s. PONI (Product Oriented Network Interface)—Is used to connect the Advantage Central Monitoring Unit (18), the Breaker Interface Module (10), and the Central Energy Display (13), an IQ Analyzer (6), and the IQ DP-4000 (7) to an INCOM network.
- t. PXGX1000 Card—Is used to connect an Eaton PDU (Power Distribution Unit) or RPP (Remote Power Panel) to an Ethernet network. Available interfaces are: HTTP (Web) SNMP, SMTP (e-mail), Modbus TCP/IP and BACnet/WS+.
- u. PXGX2000 Card—Is used to connect an Eaton UPS to an Ethernet network. Available interfaces are: HTTP (Web) SNMP, SMTP (e-mail), Modbus TCP/IP and BACnet/WS+.

Important Note: When connecting multiple Modbus RTU devices to either a multiport terminal server or a Power Xpert Gateway 400/600 over an RS-485 daisy chain network, the baud rate, data frame (stop bits, data bits and parity), byte order (standard or reversed) and physical wiring (two-wire or four-wire) must be the same for all devices connected.

Power Xpert Architecture Deployment Levels

1. Web Browser monitoring for a single device
2. Web Browser monitoring for multiple devices
3. Web Browser monitoring with centralized management
4. Customized Web-based graphics and third-party device support

Power Xpert Architecture Hardware/Software Products

Power Xpert hardware/software products were developed to provide a highly intuitive local user interface that simplifies complex real-time data into meaningful information. At a glance, a user can quickly determine if a critical parameter in their power system, (such as voltage, current or kWh), falls within or outside of an acceptable operational range.

Power Xpert devices provide the intelligent hardware connectivity layer to allow Web-enabled communications over an Ethernet TCP/IP network. These devices can act as standalone Web servers or as part of a coordinated system with Power Xpert Software consolidating and analyzing the combined system data. The Power Xpert Meter family and the Power Xpert Gateway family are microprocessor-based, Web-enabled, communicating devices from Eaton that make up the Power Xpert Architecture.

Power Xpert Meters

Power Xpert Meters 2000/4000/6000/8000 offer Eaton customers a new level of accessibility to the critical information required to manage their electrical distribution system. The meter's embedded Web server includes real-time circuit information in both numeric and graphical visual formats that can be viewed on its local display or through a Web browser via the Internet or a customer's intranet.

The Power Xpert Meters 4000/6000/8000 are the benchmark for intelligent Web-enabled power quality metering instruments. The meters include high-speed sampling and measurement of the critical elements, (i.e., voltage, power, current, transients or harmonics), in a facility's power system. See **Page V3-T9-21** for detailed information on the Power Xpert Meters.

All Power Xpert Meters provide a standard communications protocol for easy integration into other systems.

Power Xpert Gateways

Power Xpert Gateways are intelligent communication devices that Web-enable one or more electrical devices so they become visible to a browser on an Ethernet network. The Power Xpert Gateways are capable of providing communications conversion from one network field bus protocol to another—for example, INCOM to Ethernet.

Power Xpert Gateway devices are a key component in the Power Xpert Architecture. They allow a user to optimize their existing investment in Eaton's communicating devices such as IQ Meters, Digitrip™ Breaker Trip Units, Protective and Overload Relays and **IT**. Motor Starters. They can also extend state-of-the-art connectivity to third-party devices that communicate using Modbus RTU protocol over an RS-485 field bus. See **Page V3-T9-259** for detailed information on the Power Xpert Gateways.

Power Xpert Software

Power Xpert Software, an integral part of the overall Power Xpert Architecture, is a comprehensive solution for system-level management of your power infrastructure via a Web-browser, from any desktop, on one screen. Power Xpert Software is designed to take the complexity out of managing your power system and provides a clear picture of what is happening at a component, device and system level. Power Xpert Software provides insight into cost savings and downtime prevention. For detailed information on Power Xpert Software, see **Page V3-T9-14**.

Power Xpert Architecture Configuration Guidelines

With Power Xpert devices (sophisticated, Web-enabled, high-definition communications) and a simple Web browser, users can interrogate single devices directly, groups of devices connected through gateways, or connect through software managing multiple devices and gateways. Using the Eaton system, users are free to combine ways in which they view their devices. Applications generally fall into four primary categories. Eaton has developed an easy way to provide the preferred solution, using the following configuration deployment strategies as example application categories. See **Page V3-T9-8**.

Configuration Guidelines

Application Categories	Level	Description	Implementation Details
Small/Smart Hardware installation	①	Web browser access directly to an individual Power Xpert device, i.e., Power Xpert Meter or Eaton UPS w/ optional Power Xpert Gateway Series 2000 card installed.	Easy configuration to enable Web browser monitoring for a single or small amount of Eaton devices, without coordination between devices.
Medium installation	①	Web browser access to multiple Eaton devices and third-party Modbus RTU devices through the Power Xpert Gateway and/or Power Xpert Gateway Cards.	Easy setup to enable Web browser monitoring for multiple Eaton devices, as well as third-party devices that support Modbus RTU. Each Power Xpert Gateway/ Gateway Card acts as a standalone Web server.
Sophisticated installation	②	Web browser access to multiple Eaton and third-party devices through Power Xpert Software. Devices connect to Power Xpert Software by means of either direct Web-enabled cards installed inside or via Power Xpert Gateways. Includes device views for Eaton equipment as standard.	Full suite of tools available to monitor overall system health. Power Xpert provides complete control over centralized alarm notification, reporting and escalation.
Tailored solution	③	Custom Web interface design using Eaton Electrical Services group.	Integration of third-party devices and custom screens.

Power Xpert Architecture

Level 0—Small System with Smart Hardware

Example Applications

Power Xpert Meter in low voltage switchgear and UPS.

Description

Configuration Level 0 offers an easy means to Web-enable a single Eaton device provided that it is supported by an optional Web communications card that can be installed directly into the device.

Standard Features

- Real-time monitoring of metered and alarm points
- Alarm history
- E-mail notification
- Communications settings via the Web

Small Installation with Smart Hardware

Functions/Devices

Drawing Symbol	Function Description	Eaton Device
Monitoring Equipment		
MM6GWP	Power Quality Meter Analyzer	Power Xpert Meter 4000/6000/8000
MM4&P	Meter Monitor and Protection	IQ DP-4000
MM	Meter Monitor	IQ 100/IQ 200
SMM	Sub-Metering Module	IQ Energy Sentinel
Overcurrent/Short Circuit Protection		
MVTU	Medium Voltage Relay (> 600V)	DT-3000, FP-5000
LVTU	Low Voltage Trip Unit (≤ 600V)	Digitrip RMS-810, 910, 520 MC or 1150 Digitrip OPTIM 750 or 1050
Motor Protection and Control		
MPR	Motor Protective Relay	MP-3000
MMS	Microprocessor Motor Starter	IT Starter
VFD	Variable Frequency Drive	SVX9000
Central Monitoring Panels		
BIM II	Breaker Interface Module II	BIM II (used with Digitrip OPTIM or Digitrip RMS)
LDISP	Local Display and Sub-network Master	Used with IQ Multipoint Energy Submeter II or with Energy/Power Sentinels
Other Devices		
ATS	Automatic Transfer Switch	IQ Transfer
RTD	Resistance Temperature	Universal RTD Module
ADR	Addressable Relay	ADR II
C	Product Communication Device	IPONI
R	Resistor-End of Line	Resistor
■	Terminal Block	IP, IN, IS Terminal Designation
.....	Factory Twisted Pair Wiring	IMPCABLE or Belden YR29090 or Belden 9463 Family
.....	Field Twisted Pair Wiring	IMPCABLE or Belden YR29090 or Belden 9463 Family
————	Field Ethernet Backbone	CAT5 or multimode fiber

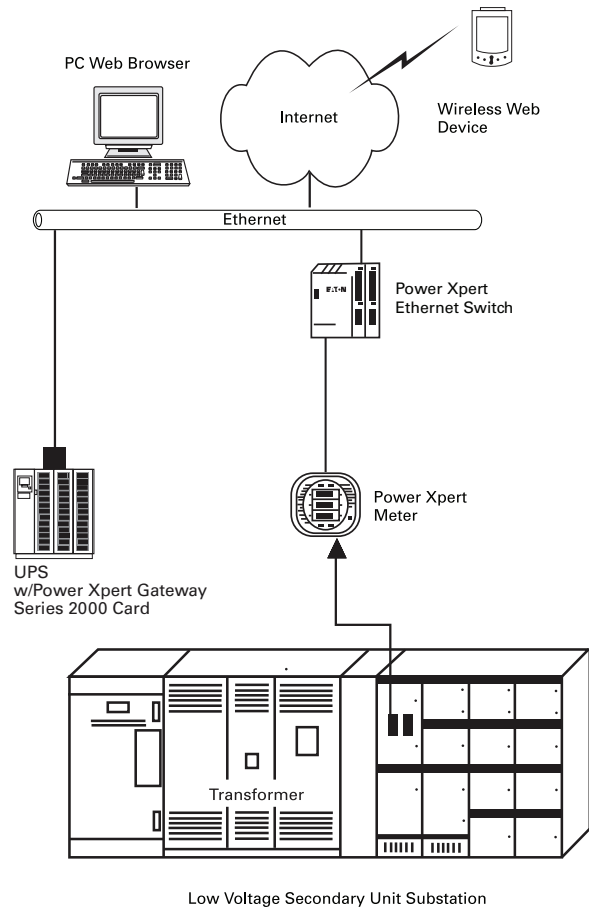

Level 1—Using Power Xpert Gateways

Example Applications

Low and medium voltage switchgear, motor control centers and third-party equipment via Modbus RTU. Recommendation: Use one Power Xpert Gateway device per electrical assembly or switchgear sub-section.

Description

Configuration Level 1 offers an easy means to Web-enable multiple Eaton devices and third-party devices that support Modbus RTU.

Standard Features

- Real-time monitoring of metered and alarm points
- Communications settings via the Web
- Alarm history
- E-mail notification

Power Xpert Gateway

Functions/Devices

Drawing Symbol	Function Description	Eaton Device
Monitoring Equipment		
MM6GWP	Power Quality Meter Analyzer	Power Xpert Meter 4000/6000/8000
MM4&P	Meter Monitor and Protection	IQ DP-4000
MM	Meter Monitor	IQ 100/IQ 200
SMM	Sub-Metering Module	IQ Energy Sentinel
Overcurrent/Short Circuit Protection		
MVTU	Medium Voltage Relay (> 600V)	DT-3000, FP-5000
LVTU	Low Voltage Trip Unit (≤ 600V)	Digitrip RMS-810, 910, 520 MC or 1150 Digitrip OPTIM 750 or 1050
Motor Protection and Control		
MPR	Motor Protective Relay	MP-3000
MMS	Microprocessor Motor Starter	IT Starter
VFD	Variable Frequency Drive	SVX9000
Central Monitoring Panels		
BIM II	Breaker Interface Module II	BIM II (used with Digitrip OPTIM or Digitrip RMS)
LDISP	Local Display and Sub-network Master	Used with IQ Multipoint Energy Submeter II or with Energy/Power Sentinels
Other Devices		
ATS	Automatic Transfer Switch	IQ Transfer
RTD	Resistance Temperature	Universal RTD Module
ADR	Addressable Relay	ADRII
C	Product Communication Device	IPONI
R	Resistor-End of Line	Resistor
■	Terminal Block	IP, IN, IS Terminal Designation
.....	Factory Twisted Pair Wiring	IMPCABLE or Belden YR29090 or Belden 9463 Family
.....	Field Twisted Pair Wiring	IMPCABLE or Belden YR29090 or Belden 9463 Family
————	Field Ethernet Backbone	CAT5 or multimode fiber

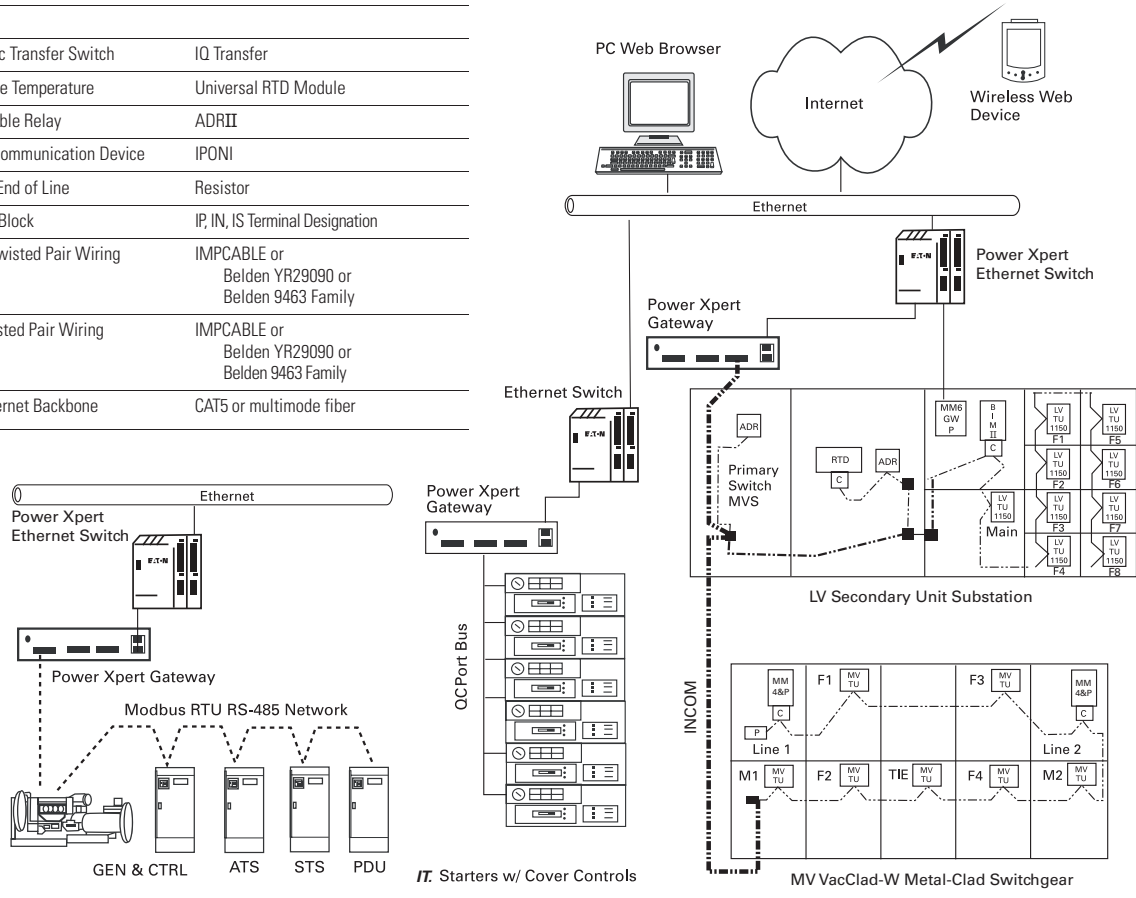

Level 2—Power Xpert Software**Example Applications**

All Eaton devices and third-party devices that support Modbus TCP and SNMP in addition to third-party Modbus RTU devices via the Power Xpert Gateway.

Description

Configuration Level 2 offers an easy means to Web-enable and centrally manage all Eaton devices that can be connected directly to an Ethernet network or via a Power Xpert Gateway device. Power Xpert Software provides a rich set of standard features, as well as premier value add-on option modules.

Standard Features

- Real-time monitoring of metered and alarm points
- Full color Web-based graphics package with standard views for all Eaton devices
- E-mail notification
- Data trending and graphing

Optional Add-on Features

- Web-based graphics editor to design floor plan and third-party device views
- Energy consumption analysis and tenant billing
- Power quality analysis and waveform viewing
- Modbus TCP tool to import register maps from various third-party devices
- SNMP tool to compile SNMP MIB (Management Information Base) files from various third-party devices

Power Xpert Software

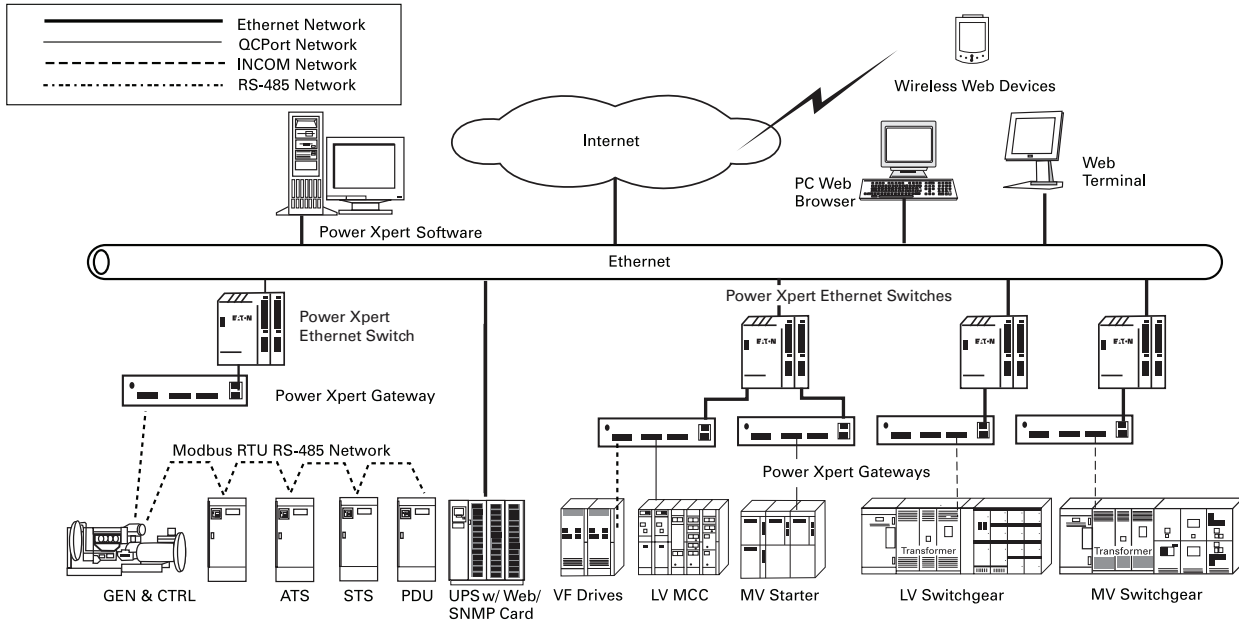

9

Functions/Devices

Drawing Symbol	Function Description	Eaton Device
Monitoring Equipment		
MM6GWP	Power Quality Meter Analyzer	Power Xpert Meter 4000/6000/8000
MM4&P	Meter Monitor and Protection	IQ DP-4000
MM	Meter Monitor	IQ 100/IQ 200
SMM	Sub-Metering Module	IQ Energy Sentinel
Overcurrent/Short Circuit Protection		
MVTU	Medium Voltage Relay (> 600V)	DT-3000, FP-5000
LVTU	Low Voltage Trip Unit (≤ 600V)	Digitrip RMS-810, 910, 520 MC or 1150/Digitrip OPTIM 750 or 1050
Motor Protection and Control		
MPR	Motor Protective Relay	MP-3000
MMS	Microprocessor Motor Starter	IT Starter
VFD	Variable Frequency Drive	SVX9000
Central Monitoring Panels		
BIM II	Breaker Interface Module II	BIM II (used with Digitrip OPTIM or Digitrip RMS)
LDISP	Local Display and Sub-network Master	Used with IQ Multipoint Energy Submeter II or with Energy/Power Sentinels
Other Devices		
ATS	Automatic Transfer Switch	IQ Transfer
RTD	Resistance Temperature	Universal RTD Module
ADR	Addressable Relay	ADRII
C	Product Communication Device	IPONI
R	Resistor-End of Line	Resistor
■	Terminal Block	IP, IN, IS Terminal Designation
-----	Factory Twisted Pair Wiring	IMPCABLE or Belden YR29090 or Belden 9463 Family
-----	Field Twisted Pair Wiring	IMPCABLE or Belden YR29090 or Belden 9463 Family
-----	Field Ethernet Backbone	CAT5 or multimode fiber

Level 3—Eaton’s Electrical Services & Systems (EESS) Customized Software Solutions

Available Applications

Any manufacturer’s equipment that is supported by the EESS extensive device driver support list or request a custom quotation to obtain support.

Description

Configuration Level 3 offers an extensive service offering for the delivery of customized graphics and support for third-party proprietary device driver support.

Enhanced Features

- Customized one-line diagrams to portray realistic operation of the complete power distribution system

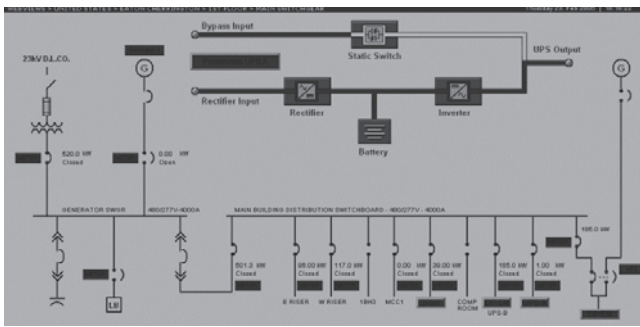

Power Distribution System One-Line Diagram

- Customized navigation systems to allow the operator to navigate the software in a similar paradigm that is consistent with the way they would describe their organization with a functional or departmental standpoint

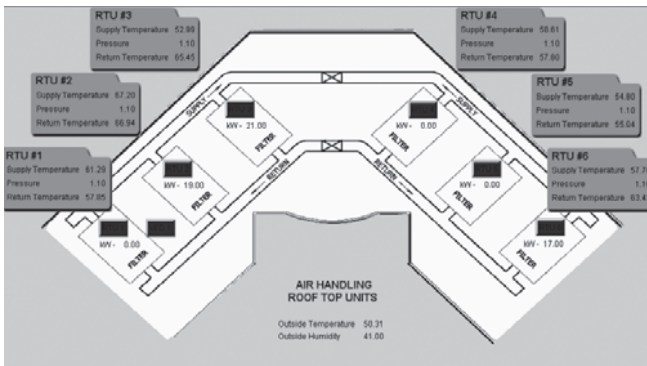

Customized Navigation System

Power Xpert Software



Contents

Description

Page

Power Xpert Software	
Product Selection Guide	V3-T9-15
Features and Benefits	V3-T9-16
Product Selection	V3-T9-19



Power Xpert Software

Product Description

Power Xpert Software is the fusion of key components of PowerNet and PowerVision Software into a single power monitoring package, which includes ease of interconnectivity to a wide range of Eaton and third-party communicating devices.

Power Xpert Software provides an easy upgrade path to allow existing PowerNet users to enjoy the benefits of power monitoring through a simple Web browser interface. It provides a complete software solution to manage your power system. Critical components such as metering devices, protective relays, circuit breaker trip units, motor starters and uninterruptible power supplies communicate vital information about the health and status of critical infrastructure devices.

Product Selection Guide

Power Xpert Software Professional Edition

- Geared toward end users, with built-in support for Eaton power distribution products such as switchgear, UPSs, breakers, PDUs, RPPs, meters, relays, VFDs and MCCs, among others
- Eaton products connect with the software directly via an Ethernet connection, while legacy devices use a Power Xpert Gateway to Web-enable their communications
- A subset of third-party meters and devices are supported as standard via the gateway connection

Power Xpert Software Enterprise Edition

- Geared toward advanced power users, system integrators and enterprises with heterogeneous device spectrum and system developers who can take advantage of the included SNMP and Modbus integration development utilities
- Extensive support for third-party devices via standard SNMP and Modbus TCP protocols
- Large variety of ready made, optional third-party drop in drivers available

Power Xpert Software Features

Feature Sets	Power Xpert Software Professional Edition	Power Xpert Software Enterprise Edition
Server module	■	■
Trend viewer module	■	■
Layout manager module	■	■
Quality manager module	■	■
Eaton device support (switchgear, UPSs, breakers, ePDUs, meters, relays, VDFs, MCCs, etc.)	■	■
Power Xpert Gateway third-party device support	■	■
SNMP connector		■
Modbus connector		■
Optional third-party driver support		■
Custom third-party device driver support		■

Features and Benefits

Power Xpert Software

Feature	Benefit
General	
Web browser user interface	There is no need to install a separate client piece of software on your computer. Simple and easy access via Web browser from any location in the world.
Web-based monitoring capabilities	Monitor all power system equipment through the Internet.
Downloadable software version updates	Receive the latest enhancements and versions via downloads available from Eaton's Web site.
Event Notification	
Event notification via e-mail notification	Receive automatic e-mails when events are triggered.
Event notification via pagers, text message or third-party interfaces	Receive alarms on event changes via pagers, text message or third-party interfaces.
Alarm state management	Acknowledge, clear and close alarms through Power Xpert Software.
Event indicator displayed without Web page active	The Web page you are on does not need to be active to display the event indicator.
Alarm/event searching and filtering	Conveniently search and filter alarms and events to quickly find what you are looking for.
Waveform attached to applicable power event	Waveforms captured by meters are attached to actual power events, making them easy to understand and interpret.
Web browser based waveform viewing	There is no need to install a separate waveform viewer on your computer. Waveforms can be easily reviewed right in your Web browser.
Alarm capabilities based on device driven events	Alarms and triggered events come to the software directly from the associated devices, eliminating false alarms.
Analysis and Trending	
Graphic Trend Viewer	Displays power system device measurements in an easy-to-understand graphical chart format.
Chart or data option selection	Conveniently view the data in either spreadsheet type data format or a graphic line chart plot.
Multiple trends display	Displaying multiple trends at a time helps analyze event ramifications and impact in more detail.
Multiple axis support	Multiple trends can be plotted on multiple x and y axis, displaying pertinent time and scale information.
View multiple variables (i.e., Ia, Ib, Ic, Vab, Vbc, etc.) for a single waveform	Multiple waveform variables can be viewed at a time, eliminating the need of changing views frequently.
Standard COMTRADE file format support	View, import and open any waveform captures in standard IEEE® (C37.111-1999) COMTRADE file format.
Customizable Trend Viewer look and feel	The formatting of the data, and the look and feel of it can be easily customized according to user preferences.
Fixed or custom time frames	Information displayed in the Trend Viewer can have either system-defined fixed or user-selected custom time frames.
Trend analysis capabilities	Trends can be easily spotted and analyzed on screen or exported to third-party software for further analysis if necessary.
Data export	Trend data can be easily exported to Excel for further analysis.
Custom Graphics and Layouts	
Custom graphics development via Web browser	Customized Web pages can be easily developed using a plain Web browser, eliminating the need to install a separate application to be installed, learned and utilized.
Four user view example templates included as standard	Easily use 'as is' or modify as necessary: data center, plant, hospital and geographical layout templates.
iFrame capability	iFrames enable embedding browser portals into custom Web page layouts.
Browser Portal Widget support	Browser Portal Widgets can be embedded in iFrames to accommodate streaming media feeds.
Streaming media support	Multiple streaming media feeds can be embedded into a single Web page, utilizing iFrames technology.
Graphic object library included as standard	A large object library including most common power devices is embedded within the system, enabling the user to develop mimic screens from the start.
ISO® standard electrical picture objects available	Add ISO standard compliant graphics to one-line diagrams or other layouts for ISO compatibility.
Graphic files import capability	Import floor plans, street maps or photographs to be used as background images or mimic objects in Web pages.
Graphic object animation capability	Graphics can be animated based on event and threshold changes. An object could change color, for example, when a threshold is reached.
Gauge object library support	A multitude of gauges are provided in the standard object library to enable easy Web page custom measurement gauges design.
External Web links support	Add Web links to Power Xpert Software pages, which link to any device, Web page on the Internet and network around the globe with a Web user interface.
Alarm bubble-up support through several page layers	Alarms can be easily bubbled-up through multiple Web pages with the folder link feature. Event can be seen on the topmost page and the user can drill down for more information.
Trend object support	Trend objects can be embedded into the layout, enabling viewing the data directly in the Trend Viewer.

Power Xpert Software, continued

Feature	Benefit
UPS Shutdown	
File saving during shutdown	During an emergency shutdown due to an extended power failure outlasting the UPS battery, open files on the computer systems are closed and saved in an orderly fashion.
Automatic, orderly and sequential shutdown	All operating systems running Power Xpert Software Shutdown Agent will be shut down in an orderly and sequential fashion to prevent data loss.
Parallel redundant UPS shutdown capability	Built-in software logic will initiate shutdown only after UPS redundancy has been lost and the last UPS is out of runtime.
Security and Administration	
Windows Authentication Security	Control access to Power Xpert Software via Windows® Authentication Service.
Two-tier secure system access support	Access the Power Xpert Software with read or write privileges to prevent unauthorized tampering.
SSL	Supported via OpenSSL.
Secure Web browser access (support for HTTPS)	Supported via OpenSSL.
Time Synchronization	
Time synchronization support for connected devices with 1 millisecond time resolution	Millisecond-based timestamp support (when supported by connected device) enables understanding the sequence of rapidly occurring events.
Export and Integration	
Extended Excel® spreadsheet support	Open report files directly in Excel.
SQL database query support	Power Xpert uses standard SQL database format that can be queried by third-party applications for system integration and data exchange.
Logs	
System Log	The System Log gathers information on system-level events for error and security purposes.
Error Log	The Error Log gathers information on errors occurred for diagnostic purposes.
Service	
Eaton help desk services (1-877-ETN-CARE)	Call Eaton to speak directly to a product specialist providing support for the software.
Turnkey startup service	Purchase a 1, 2 or 5-day startup service package from Eaton for turnkey system installation and configuration.
System Backup	
Power Xpert Software system backup	Easily back up Power Xpert software including configurations, user views and device setups.
Documentation and Training Videos	
System Administrator's Guide	Guides users on how to administer Power Xpert Software.
Power Xpert Software User's Guide	Detailed information of Power Xpert Software features and functionality along with screenshots and references.
Layout Manager Guide	Detailed information on how to use Layout Manager's features and functionality to create custom graphic system pages.
Quick Start Guide	Takes the guesswork out of initial software installation and configuration with clear step-by-step instructions on how to get started.
Power Xpert Software Introduction and Training Video	Learn the main features and functionality of Power Xpert Software by watching a hands-on video showing you how to install, configure and use the software.
Power Xpert Reporting Introduction and Training Video	Learn the main features and functionality of Power Xpert Reporting by watching a hands-on video showing you how to install and configure reporting. Included are step-by-step instructions on how create reporting hierarchies and pull data out of different databases.

Note: These specifications are subject to change without notice and represent the maximum capabilities of the product with all options installed. This is not a complete feature list. Features and functionality may vary depending on selected options and product model. Please refer to the technical data sheet and user manual for detailed specifications.

Communication Protocol Support

Communication Protocol	Description
Dry-contact/contact closure/relay	Contact closure support is enabled via various Eaton Gateway devices. Please refer to Power Xpert Software Hardware Compatibility List for details.
BACnet WS+	BACnet WS+
Modbus RTU	Modbus RTU
Modbus TCP	Modbus Protocol over TCP
TCP/IP	Transmission Control Protocol
SNMP	Simple Network Management Protocol
SMTP	Simple Mail Transfer Protocol
INCOM	Eaton Legacy Protocol
HTTP	Hypertext Transfer Protocol
HTTPS	Hypertext Transfer Protocol with SSL
SSL	Secure Sockets Layer

Power Xpert Reporting—the perfect complement

Power Xpert Reporting helps bring information from the software together. Power Xpert Software brings together your power system information from around the floor to around the world—data and information that is invaluable. Power Xpert Reporting brings all the power system information together to compare, contrast and generally give you the big picture. Power Xpert Reporting provides a standard set of reports, including:

- **Data Center Efficiency Report:** A summary of data center infrastructure efficiency and power usage effectiveness, including such information as temperature and humidity, and energy consumption
- **Greenhouse Gas Report:** Captures the six offensive greenhouse gasses: Carbon Dioxide, Sulfur Dioxide, Nitrogen Oxide, Mercury, Methane and Nitrous Oxide broken down by selected locations within a facility
- **Utilities Report:** Captures consumption of water, air, gas, electricity and steam (WAGES)
- **Capacity Summary Report:** The summary of top- and bottom-loaded circuits, as well as loading details for each circuit according to user-defined date/time range and facility hierarchy location
- **Branch Circuit Monitoring Report:** Determine branch circuit loading levels at a glance with color-coded graphics indicating loading status against capacity. Redundant sources can be reviewed, as well as single source loads
- **Energy Summary Report:** The summary of consumption (kWh) and demand (kW) for a user-defined date/time range and facility hierarchy location
- **Energy Cost Allocation Report:** The total energy bill dollar value or a cost per kWh across a facility hierarchy for a user-defined date/time range
- **Power Quality Report:** The distribution and trend for amps, volts and THD according to user-defined date/time ranges and facility hierarchy location
- **Event Summary Report:** Provides a Pareto chart of events according to user-defined date/time ranges and facility hierarchy location
- **Joint Commission Report:** Standard Joint Commission compliant report supports hospital power test requirements. It checks events, key metrics of generators and automatic transfer switches (ATS) during generator testing at user-defined date/time ranges and facility hierarchy location

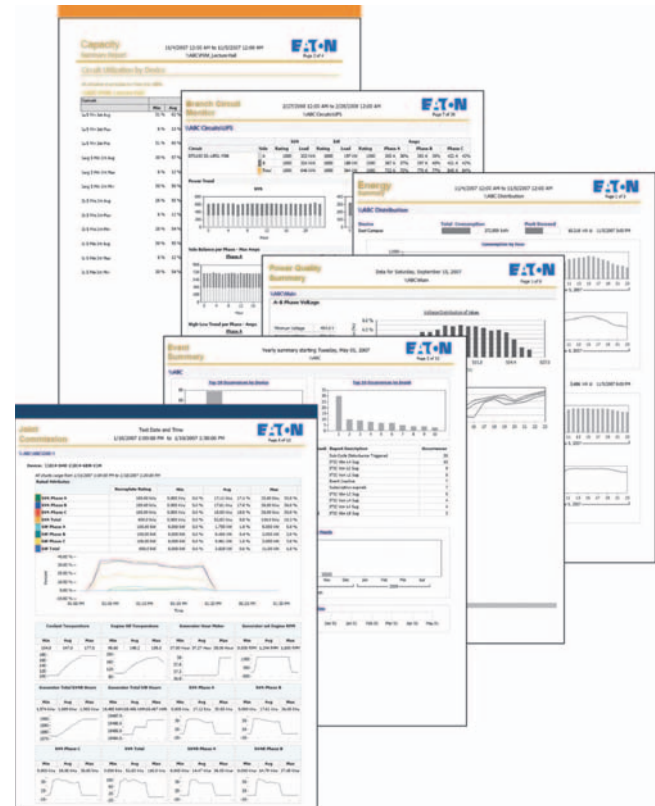

Product Selection

Power Xpert Software

Description	Catalog Number
Power Xpert Software Professional Edition	
Power Xpert Software Professional Edition	PXS-PRO
Power Xpert Software Professional Edition w/ 1-day startup	PXS-PROn1S
Power Xpert Software Professional Edition w/ 2-day startup	PXS-PROn2S
Power Xpert Software Professional Edition w/ 5-day startup	PXS-PROn5S
Power Xpert Software Professional Edition and Power Xpert Reporting	PXS-PROnPXR
Power Xpert Software Enterprise Edition	
Power Xpert Software Enterprise Edition	PXS-ENT
Power Xpert Software Enterprise Edition w/ 1-day startup	PXS-ENTn1S
Power Xpert Software Enterprise Edition w/ 2-day startup	PXS-ENTn2S
Power Xpert Software Enterprise Edition w/ 5-day startup	PXS-ENTn5S
Power Xpert Reporting	
Power Xpert Reporting—single source DB connection	PXR
Power Xpert Reporting—up to 2 source DB connections	PXR-2DB
Power Xpert Reporting—up to 5 source DB connections	PXR-5DB
Power Xpert Reporting—up to 10 source DB connections	PXR-10DB
Power Xpert Reporting—up to 25 source DB connections	PXR-25DB
Power Xpert Reporting—up to 50 source DB connections	PXR-50DB
Service Packs	
Power Xpert 1-day startup Service Pack	PX-1S
Power Xpert 2-day startup Service Pack	PX-2S
Power Xpert 5-day startup Service Pack	PX-5S

Technical Data and Specifications

Hardware Requirements

Power Xpert Software (PXS) requires a server-class machine with the following minimum hardware specifications:

Hardware	Specification
Processor	2.8 GHz, dual-core processor
Memory	2 GB allocated for PXS (allocate 3 GB of memory to a virtual machine session running PXS)
Disk space required for application	The PXS application itself requires 190 MB of disk storage
Disk space required for database	A typical database will grow to 2 GB within a year. If you have a large number of devices, reserve additional storage space
Video resolution	1280 by 1024 pixels or higher
Removable media	DVD RO driv

You may wish to add the following hardware as well:

- Local printer
- Sound card (if sounds are assigned to specific alarm conditions)
- Modem (for remote alarm notification to machines not available via your network)

Software Requirements

Supported operating systems

- Microsoft® Windows Server 2003 R2 (Standard or Enterprise) 32-bit edition
- Microsoft Windows XP Professional (32-bit) with Service Pack 3, 32-bit
- Windows Server 2008 (Standard or Enterprise), 32-bit or 64-bit
- Windows Server 2008 R2 (Server or Enterprise), 32-bit or 64-bit
- Windows 7 Professional, Ultimate or Enterprise editions, either 32-bit or 64-bit

Software components

- IIS 5.0 or higher (must be installed prior to installing PXS; for Windows 7 and Windows Server 2008, this is installed automatically)
- Microsoft Internet Explorer® 7.0 or 8.0

Third-Party Software Installed

The following Microsoft software is also installed during the PXS installation.

- .NET Framework 3.5 SP1
- Windows Installer 4.5
- C++ Runtime Library 2008
- Microsoft Data Access 2.8
- SQL Server 2008 Express SP2
- SQL Server 2005 Express Management Studio SP2

Metering Products Family



Contents

<i>Description</i>	<i>Page</i>
Metering Products Family	
Power Xpert Meter 4000/6000/8000 Series	V3-T9-30
Power Xpert Meter 2000 Series	V3-T9-49
IQ 250/260 Series Electronic Power Meters	V3-T9-60
IQ 130/140/150 Series Electronic Power Meters	V3-T9-66
IQ 150S/250S Self-Enclosed Electronic Meters	V3-T9-71
IQ 35M	V3-T9-76
IQ Analyzer 6400/6600 Series	V3-T9-79
IQ DP-4000 Series	V3-T9-87
IQ 230 Meters	V3-T9-93
Power Xpert Multi-Point Meter	V3-T9-100
IQ Energy Sentinel™	V3-T9-112
PM3 Monitoring and Metering Module	V3-T9-121
Current Transformers (CTs)	V3-T9-122
Clamp-On Current Transformers	V3-T9-131
IQ Flange	V3-T9-134
Panel Mounting Adapter Kit	V3-T9-135
Enclosed Meters	V3-T9-136

Product Overview

Eaton’s metering products provide solutions needed to monitor and manage all aspects of an electrical distribution system.

When greater reliability, increased productivity and significant cost savings are called for to remain competitive in today’s market, Eaton’s metering products fit the bill. These innovative meters and communications systems, along with Power Management software, make it possible to successfully take control of the electrical distribution system.

Power Xpert Meters

Power Xpert Meters are the benchmark for intelligent Web-enabled top-quality metering devices for the power system. Power Xpert Meters provide measurement of the critical elements found in the power system, whether that be voltage, power, current, transients, harmonics or even time. Power Xpert Meters provide Web-enabled communications for use with the Power Xpert Software. All Power Xpert Meters provide a standard communications protocol for easy integration into other systems.

Features and Benefits

Greater Reliability

Eaton’s metering products give the ability to receive an early warning of potential problems, eliminate unnecessary trips, isolate faults to ensure minimum downtime and shed or equalize loads while a problem is being corrected.

Increased Productivity

Equipment downtime resulting from voltage or frequency variations can be very costly to an operation. Monitoring power quality with Eaton’s metering products throughout the electrical distribution system provides data to identify, isolate and correct problems quickly and efficiently.

Reduced Energy and Operating Costs

When we think about meters and power quality, the common thread throughout the basket of solutions is information. Collecting, monitoring and managing data from the electrical distribution system can help reduce costs for those facilities prepared to define and analyze present electrical energy usage levels and patterns. Data provided by Eaton’s metering products comprise the data for verifying utility bills for energy management and lowering operating costs. Deregulation in some geographical locations permits energy users to select a utility provider and negotiate rate structures. For large users with heavy utility bills, this may be an incentive to verify the utility bill, identify an opportunity for savings, negotiate a better utility rate and apply the savings directly to the bottom line. Users are also empowered to decrease energy consumption, thereby lowering peak demand charges and decreasing operating costs.

When an Eaton meter is used with Eaton trip units and relays incorporating built-in metering capabilities, the entire electrical distribution system can be cost-effectively managed.

Eaton is an industry leader offering a complete integrated solution to oversee your entire electrical distribution system. As a global manufacturer of low and medium voltage electrical distribution system equipment and components, Eaton is an experienced innovator of metering products that incorporate cutting-edge technology. These innovations result from our scientific and engineering expertise, physical resources and the ongoing R&D programs at our technology centers.

Product Selection Guide

Metering Selection Chart

Power Xpert Meter 4000/6000/8000 Series



Power Xpert Meter 2000 Series



IQ 250/260 Series



Device Name
Accessories
See Page V3-T9-131

Section Page Number

V3-T9-30

V3-T9-49

V3-T9-60

Electrical Parameters

Volts	0.1% of RV + 0.02% FS	0.1% of RV	0.1% of RV
Amperes	0.05% of RV + 0.01% FS	0.1% of RV	0.1% of RV
Current range (% of nominal)	0.005–20A (400%)	0.1–200%	0.1–200%
Watts	0.1% of RV + 0.0025% FS	0.2% of RV	0.2% of RV
VARs	0.1% of RV + 0.0025% FS	0.2% of RV	0.2% of RV
VA	0.1% of RV + 0.0025% FS	0.2% of RV	0.2% of RV
PF-apparent	0.1%	0.2% of RV	0.2% of RV
PF-displacement	0.1%	—	—
Frequency	±0.01 Hz	±0.03 Hz	±0.03 Hz
THD-voltage	127th	40th ②③④⑤	40th ⑥
THD-current	127th	40th ②③④⑤	40th ⑥
Watt-hours	±0.2% per ANSI C12.20 0.2 Class ①	±0.2% per ANSI C12.20 0.2 Class ①	±0.2% per ANSI C12.20 0.2 Class ①
VAR-hours	±0.2% per ANSI C12.20 0.2 Class ①	±0.2% per ANSI C12.20 0.2 Class ①	±0.2% per ANSI C12.20 0.2 Class ①
VA-hours	±0.2% per ANSI C12.20 0.2 Class ①	±0.2% per ANSI C12.20 0.2 Class ①	±0.2% per ANSI C12.20 0.2 Class ①
Ampere-demand	0.05% of RV + 0.01% FS	±0.1% per ANSI C12.20 0.2 Class	±0.1% per ANSI C12.20 0.2 Class
Watt-demand	±0.2% per ANSI C12.20 0.2 Class ①	±0.2% per ANSI C12.20 0.2 Class ①	±0.2% per ANSI C12.20 0.2 Class ①
VAR-demand	±0.2% per ANSI C12.20 0.2 Class ①	±0.2% per ANSI C12.20 0.2 Class ①	±0.2% per ANSI C12.20 0.2 Class ①
VA-demand	±0.2% per ANSI C12.20 0.2 Class ①	±0.2% per ANSI C12.20 0.2 Class ①	±0.2% per ANSI C12.20 0.2 Class ①
Revenue accuracy	±0.2% per ANSI C12.20 0.2 Class ①	ANSI C12.20 (0.2%)	ANSI C12.20 (0.2%)
Individual ampere harmonics	85th ⑦	40th ③④⑤	—
Individual voltage harmonics	85th ⑦	40th ③④⑤	—
Interharmonics	Yes	—	—

Minimum and/or Maximum Values

Volts	L-L, L-N, N-G, VAUX L-L	L-L, L-N	L-L, L-N
Current	A, B, C, N, G	A, B, C, N	A, B, C
Power	Watt, VAR, VA	Watt, VAR, VA	Watt, VAR, VA
Power Factor	Apparent/displacement	Apparent	Apparent
Frequency	Hertz	Hertz	Hertz
THD	Amperes/volts (L-L, L-N, AUX L-L)	Amperes/volts ②③④⑤	Amperes/volts ⑥
Demand values	kW, kVAR, kVA, amperes	kW, kVAR, kVA, amperes	kW, kVAR, kVA, amperes
Trend analysis	2 / 4 ⑧ / 8 ⑨ GB	256 / 512 ② / 768 ③④⑤ MB	128 KB ⑩
Event logging	2 / 4 ⑧ / 8 ⑨ GB	100,000 alarms/events with timestamp	⑩
Disturbance recording	2 / 4 ⑧ / 8 ⑨ GB 60 cycles per event	768 MB ③⑤ up to 64 cycles per event ④⑤	—

Notes

- ① Under typical operating conditions.
- ② PXM 2260 only.
- ③ PXM 2270 only.
- ④ PXM 2280 only.
- ⑤ PXM 2290 only.
- ⑥ IQ 260 only.

- ⑦ Individual values reported to 85th harmonic; anti-alias filtering prevents higher frequencies from distorting readings (see IEC 61000-4-7).

- ⑧ PMX 6000 only.
- ⑨ PXM 8000 only.
- ⑩ Optional.
- ⑪ At computer only.

Legend: PG = Programmable
FS = Full scale
RV = Read value

Auxiliary voltage (optional) = Provides three additional voltage inputs to the meter: Va2, Vb2, Vc2.

Interharmonics = Power Xpert Meter 6000/8000 supported.

Metering Selection Chart, continued

Power Xpert Meter 4000/6000/8000 Series



Power Xpert Meter 2000 Series



IQ 250/260 Series



Device Name
Accessories
See Page V3-T9-131

Section Page Number

V3-T9-30

V3-T9-49

V3-T9-60

Other Features

Storage	2 / 4 ^① / 8 ^② GB	256 / 512 ^③ / 768 ^④ MB Standard	128 KB for logging, up to 8 parameters every 15 minutes for 30 days
PG output relays	5 maximum	Optional (2) Form C, 5A or (4) Form A, 120 mA	Optional (2) Form C, 5A or (4) Form A, 120 mA
PG analog outputs	—	Optional (4) 4–20 mA or (4) 0–1 mA	Optional (4) 4–20 mA or (4) 0–1 mA
Discrete contact inputs	8	Optional (2) or (4)	Optional (2) or (4)
Analog inputs	—	—	—
Synch-input kW utility	Via status input	Via end of interval pulse with optional digital inputs	Via end of interval pulse with optional digital inputs
Auxiliary voltage ^⑤	Yes	—	—
kWh pulse initiator	Yes	Yes	Yes
Waveform display	Local/computer	^⑥	—
Waveform capture, samples/cycle	Yes, 512 (4096 oversampling)	Yes, up to 64 ^⑦ , up to 512 ^⑧	—
Frequency distribution display	—	—	—
Display type	LCD ^⑨	Red LED	Red LED
Display lines/character	Graphic (320 x 240 pixels)	3 lines, 4 characters	3 lines, 4 characters
Display character height	5.5 mm H x 4 mm W	0.56 (14.2) H	0.56 (14.2) H
Communications	Serial: Modbus RTU, Modbus ASCII ^⑨ Network: Modbus TCP, Ethernet TCP/IP, HTTP, SNMP, SMTP, FTP, DNP 3.0	Serial: Modbus RTU, Modbus ASCII, DNP 3.0 Network: Modbus TCP, BACnet/IP, Ethernet TCP/IP, HTTP, HTTPS, SNMP, SMTP, ^⑦ ^⑧ Waveform FTP	Serial: Modbus RTU, Modbus ASCII, DNP 3.0 Network: Modbus TCP via Power Xpert Gateway
Setup configuration	Via Web browser/display	Via Web browser/display	Via configuration software/display
Dimensions	Refer to TD02601007E	Refer to TD02601017E	Refer to TD02601016E
Operating temperature range	–20° to 60°C display unit –20° to 70°C meter base unit	–20° to 70°C	–20° to 70°C
Reference literature	TD02601007E	TD02601017E	TD02601016E

Notes

- ① PXM 6000 only.
- ② PXM 8000 only.
- ③ PXM 2260 only.
- ④ PXM 2270 only.
- ⑤ The auxiliary voltage option adds three additional voltage input channels to Power Xpert Meters.
- ⑥ At computer only.
- ⑦ PXM 2280 only.
- ⑧ PXM 2290 only.
- ⑨ Optional

Legend: PG = Programmable
FS = Full scale
RV = Read value

Auxiliary voltage (optional) = Provides three additional voltage inputs to the meter: Va2, Vb2, Vc2.

Interharmonics = Power Xpert Meter 6000/8000 supported.

Metering Selection Chart, continued

IQ 130/140/150 Series



IQ 150S/250S Series



IQ 35M Series



Device Name
Accessories
See Page V3-T9-131

Section Page Number

V3-T9-66

V3-T9-71

V3-T9-76

Electrical Parameters

Volts	±0.25% of RV	0.1% of RV	0.4% +0.015% per °C deviation from 25°C
Amperes	±0.25% of RV	0.1% of RV	0.4% (5–100%), 0.8% (1–5%) +0.015% per °C from 25°C
Current range (% of nominal)	0.1–200%	0.1–200%	1–120%
Watts	0.5% of RV ^①	0.2% of RV	0.5% per ANSI C12.20 and IEC 62053-22 Class 0.5S
VARs	0.5% of RV ^①	0.2% of RV	2.0% per IEC 62053-23 Class 2
VA	0.5% of RV ^①	0.2% of RV	Calculated: vector sum of watts and VARs
PF-apparent	0.5% of RV ^①	0.2% of RV	Calculated: Watts / VAs
PF-displacement	—	—	—
Frequency	±0.03% Hz ^①	±0.03 Hz	±0.02 Hz
THD-voltage	—	—	—
THD-current	—	—	—
Watt-hours	±0.5% per ANSI C12.20 0.5 Class ^②	±0.2% per ANSI C12.20 0.2 Class	0.5% per ANSI C12.20 and IEC 62053-22 Class 0.5S
Var-hours	±0.5% per ANSI C12.20 0.5 Class ^②	±0.2% per ANSI C12.20 0.2 Class	±2.0% per IEC 62053-23 Class 2
VA-hours	±0.5% per ANSI C12.20 0.5 Class ^②	±0.2% per ANSI C12.20 0.2 Class	—
Ampere-demand	±0.5% per ANSI C12.20 0.5 Class ^②	±0.1% per ANSI C12.20 0.2 Class	—
Watt-demand	±0.5% per ANSI C12.20 0.5 Class ^②	±0.2% per ANSI C12.20 0.2 Class	0.5% per ANSI C12.20 and IEC 62053-22 Class 0.5S
VAR-demand	±0.5% per ANSI C12.20 0.5 Class ^②	±0.2% per ANSI C12.20 0.2 Class	2.0% per IEC 62053-23 Class 2
VA-demand	±0.5% per ANSI C12.20 0.5 Class ^②	±0.2% per ANSI C12.20 0.2 Class	Calculated: vector sum of watts and VARs
Revenue accuracy	ANSI C12.20 (0.5%)	ANSI C12.20 (0.2%)	0.5% per ANSI C12.20 and IEC 62053-22 Class 0.5S
Individual ampere harmonics	—	—	—
Individual voltage harmonics	—	—	—
Interharmonics	—	—	—
Minimum and/or Maximum Values			
Volts	L-L, L-N	L-L, L-N	—
Current	A, B, C	A, B, C	—
Power	Watt, VAR, VA	Watt, VAR, VA	—
Power factor	Apparent ^①	Apparent	Apparent (low alert)
Frequency	Hertz ^①	Hertz	Hertz (out of range alert)
THD	Ampere/Volts	—	—
Demand values	kW, kVAR, kVA, amperes ^③	kW, kVAR, kVA, amperes	kW, kVAR, kVA; Maximum kW, kVAR, kVA
Trend analysis	^③	2 MB ^⑤	—
Event logging	^③	2 MB ^⑤	Logging on demand interval or Modbus command ^④
Disturbance recording	—	—	—

Notes

- ① IQ 140 and IQ 150.
- ② IQ 150 only.
- ③ At computer only.
- ④ Optional.
- ⑤ IQ 250S only.

Legend: PG = Programmable
FS = Full scale
RV = Read value

Metering Selection Chart, continued

IQ 130/140/150 Series



IQ 150S/250S Series



IQ 35M Series



Device Name
Accessories
See Page V3-T9-131

Section Page Number

V3-T9-66

V3-T9-71

V3-T9-76

Other Features

Storage	—	2 MB ^②	10 registers (16 bit) by 5760 entries each (115 KB) ^①
PG output relays	—	—	—
PG analog outputs	—	—	—
Discrete contact inputs	—	—	2 pulse inputs with BACnet
Analog inputs	—	—	—
Synch-input kW Utility	—	—	Optional demand synchronization via Modbus
Auxiliary voltage ^③	—	—	—
kWh pulse initiator	^①	Yes	Yes
Waveform display	—	—	—
Waveform capture	—	—	—
Frequency distribution display	—	—	—
Display type	Red LED	Red LED	Backlit LCD
Display lines/character	3 lines, 4 characters	3 lines, 4 characters	2 lines by 5 characters ea (full alphanumeric top row)
Display character height	0.56 (14.2) H	0.56 (14.2) H	7.5 mm
Communications	Serial: Modbus RTU, Modbus ASCII ^① Network: Modbus TCP ^①	Serial: Modbus RTU, Modbus ASCII, DNP 3.0 Network: Modbus TCP, wired or wireless	Serial: Modbus RTU ^① , BACnet MS/TP ^① Network: Modbus TCP via Power Xpert Gateway
Setup configuration	Via configuration software/display	Via configuration software/display	Via display/configuration software
Dimensions	4.85 (123.2) H x 4.85 (123.2) W x 4.97 (126.2) D	7.90 (200.7) H x 7.50 (190.5) W x 3.10 (78.7) D	3.60 (91.4) H x 4.20 (106.7) W x 2.30 (58.4) D
Operating temperature range	–20 to 70°C	–20 to 70°C	–20 to 70°C
Reference literature	TD02601015E	TD02601019E	TD02601015E

Notes

- ^① Optional.
- ^② IQ 250S only.
- ^③ The auxiliary voltage option adds three additional voltage input channels to Power Xpert Meters.

Legend: PG = Programmable
FS = Full scale
RV = Read value

Metering Selection Chart, continued

<p>Device Name Accessories See Page V3-T9-131</p>	<p>IQ Analyzer 6000 Series</p> 	<p>IQ DP-4000 Series</p> 	<p>IQ 230 Series</p> 
	V3-T9-79	V3-T9-87	V3-T9-93

Electrical Parameters			
Volts	±0.2% FS ①	±0.3% FS	±0.5% FS
Amperes	±0.2% FS ①	±0.3% FS	±0.5% FS
Current range (% of nominal)	3–800%	10–250%	1–200%
Watts	0.4% FS, 6 RV ②	±0.6% FS	±1.0% FS
VARs	0.4% FS, 6 RV ③	±0.6% FS	±1.0% FS
VA	0.4% FS, 6 RV ②	±0.6% FS	±1.0% FS
PF-apparent	0.8% FS ①	±1.0% FS	±2.0% FS
PF-displacement	0.8% FS ①	±1.0% FS	±2.0% FS
Frequency	0.04% ① or 0.01 Hz	±0.17% FS	±0.1% Hz
THD-voltage	50th	31st	—
THD-current	50th	31st	—
Watt-hours	0.5% RV ②	±0.6% FS	±1.0% per ANSI C12
Var-hours	1% RV ③	±0.6% FS	±1.0% per ANSI C12
VA-hours	0.5% RV ②	±0.6% FS	±1.0% per ANSI C12
Ampere-demand	±0.2% FS ①	±0.3%	±0.5% per ANSI C12
Watt-demand	±0.4% FS ①	±0.6%	±1.0% per ANSI C12
VAR-demand	±0.4% FS ①	±0.6%	±1.0% per ANSI C12
VA-demand	±0.4% FS ①	±0.6%	±1.0% per ANSI C12
Revenue accuracy	ANSI C12.20 (0.5%)	—	ANSI C12.1 (1%)
Individual ampere harmonics	50th	—	—
Individual voltage harmonics	50th	—	—
Interharmonics	—	—	—
Minimum and/or Maximum Values			
Volts	L-L, L-N	L-L, L-N	L-L, L-N
Current	A, B, C, N, G	A, B, C	A, B, C
Power	Watt, VAR, VA	Watt, VAR, VA	Watt, VAR, VA
Power factor	Apparent/displacement	Apparent/displacement	Apparent/displacement
Frequency	Hertz	Hertz	Hertz
THD	Amperes/volts	Amperes/volts	—
Demand values	All	All	All
Trend analysis	Time/date	2 alarms	④
Event logging	504 events w/timestamp	④	④
Disturbance recording	10 waveform events	—	—

Notes

- ① From 3–300% of FS.
- ② At unity power factory and 5–300% of FS.
- ③ At a power factor <±0.5 and 5–300% of FS.
- ④ At computer only.

Legend: PG = Programmable
 FS = Full scale
 RV = Read value

Metering Selection Chart, continued

	IQ Analyzer 6000 Series	IQ DP-4000 Series	IQ 230 Series
Device Name			
Accessories			
See Page V3-T9-131			
Section Page Number	V3-T9-79	V3-T9-87	V3-T9-93
Other Features			
Storage	90 KB	15 parameters	—
PG output relays	(4) 10A Form C ^①	(3) 10A Form C ^②	(2) 100 mA Form A
PG analog outputs	(4) 0–10/4–20 mA	—	—
Discrete contact inputs	(3) + 30 Vdc differential	(1) kW Demand ^②	(2) +30 Vdc differential
Analog inputs	(1) 0–20/4–20 mA	—	(1) 4–20 mA
Synch-input kW Utility	At device or via communications	At device or via communications ^②	Via communications only
Auxiliary voltage	—	—	—
kWh pulse initiator	Yes	Yes ^②	Yes
Waveform display	Local ^② /computer	—	—
Waveform capture, samples/cycle	Yes, 128	—	—
Frequency distribution display	Local ^② /computer	—	—
Display type	Graphic LCD with LED backlight	7 Segment LED	Backlit LCD
Display lines/character	7 lines, 147 characters	1 line, 7 characters	4 lines, 20 characters
Display character height	Up to 7 lines	1 line	1.60 (40.6) H x .09 (2.3) W
Communications	Serial: INCOM ^③ Network: via Power Xpert Gateway ^③	Serial: INCOM ^③ Network: via Power Xpert Gateway ^③	Serial: INCOM, Modbus RTU ^④ Network: via Power Xpert Gateway
Setup configuration	Via configuration software/display	Via configuration software/display	Via configuration software/display
Dimensions	Refer to TD1702BTE	Refer to TD1703ATE	Refer to TD1706ATE
Operating temperature range	–20° to 70°C	–20° to 70°C	0° to 50°C
Reference literature	—	—	—

Notes

- ① Relays programmable to operate on any measured function.
- ② Optional.
- ③ An IPONI is required.
- ④ IQ 230M only.

Legend: PG = Programmable
 FS = Full scale
 RV = Read value

Metering Selection Chart, continued

**Power Xpert
Multi-Point Meter**



**IQ Energy
Sentinel**



Device Name
Accessories
See Page V3-T9-131

Section Page Number

V3-T9-100

V3-T9-112

Electrical Parameters

Volts	±0.2% RV	—
Amperes	±0.2% RV	—
Current range (% of nominal)	—	—
Watts	±0.5% RV	±1.0% FS
VARs	±0.5% RV	—
VA	±0.5% RV	—
PF-apparent	±0.5% RV	—
PF-displacement	—	—
Frequency	±0.1 Hz	—
THD-voltage	—	—
THD-current	—	—
Watt-hours	±0.5% per ANSI C12.20 0.5 class	±1.0% FS
VAR-hours	±0.5% per ANSI C12.20 0.5 class	—
VA-hours	±0.5% per ANSI C12.20 0.5 class	—
Ampere-demand	—	—
Watt-demand	±0.5% per ANSI C12.20 0.5 class	±1.0% FS
VAR-demand	±0.5% per ANSI C12.20 0.5 class	—
VA-demand	±0.5% per ANSI C12.20 0.5 class	—
Revenue accuracy	ANSI C12.20 (0.5%)	—
Individual ampere harmonics	—	—
Individual voltage harmonics	—	—
Interharmonics	—	—
Minimum and/or Maximum Values		
Volts	L-L, L-N	—
Current	A, B, C	—
Power	Watts, VAR, VA	—
Power factor	Apparent	—
Frequency	Hertz	—
THD	—	—
Demand values	Watts (Delivered & Received), Watts (Q1–Q4), VA (Q1, Q4), VA (Q2, Q3)	—
Trend analysis	Interval data	①
Event logging	20 latest events and historical	①
Disturbance recording	—	—

Note

① At computer only.

Legend: PG = Programmable
FS = Full scale
RV = Read value

Metering Selection Chart, continued

**Power Xpert
Multi-Point Meter**



**IQ Energy
Sentinel**



Device Name
Accessories
See Page V3-T9-131

Section Page Number

V3-T9-100

V3-T9-112

Other Features

Storage	256 MB standard, 2 GB optional	—
PG output relays	1 standard, 8 each module ①	—
Discrete contact inputs	3 standard, 8 each module ①	—
Analog inputs	—	—
Synch-input kW utility	Via communications and digital input	Via communications only
Auxiliary voltage	—	—
kWh pulse initiator	Aggregate or main-digital output, LED output on meter modules (accuracy check)	—
Waveform display	—	—
Waveform capture	—	—
Frequency distribution display	—	—
Display type	LCD color touchscreen ①	—
Display lines/character	6-inch diagonal	—
Display character height	Graphics	—
Communications	Serial: Modbus RTU ① Network: Modbus TCP, BACnet/IP, Ethernet TCP/IP, HTTP, HTTPS, SNMP, SMTP, SFTP	Serial: INCOM Network: via Power Xpert Gateway
Setup configuration	Via PXMP configuration software	Via configuration software
Dimensions	Refer to TD150006EN (see Page V3-T9-110)	Refer to TD1707TE
Operating temperature range	–20° to 70°C	–25° to 70°C
Reference literature	TD150006EN	—

Note

① Optional.

Legend: PG = Programmable
FS = Full scale
RV = Read value

Power Xpert 4000/6000/8000 Series Display and Meter



Contents

<i>Description</i>	<i>Page</i>
Metering Products Family	V3-T9-21
Power Xpert Meter 4000/6000/8000 Series	
Power Xpert Meter 2000 Series	V3-T9-49
IQ 250/260 Series Electronic Power Meters	V3-T9-60
IQ 130/140/150 Series Electronic Power Meters	V3-T9-66
IQ 150S/250S Self-Enclosed Electronic Meters	V3-T9-71
IQ 35M	V3-T9-76
IQ Analyzer 6400/6600 Series	V3-T9-79
IQ DP-4000 Series	V3-T9-87
IQ 230 Meters	V3-T9-93
Power Xpert Multi-Point Meter	V3-T9-100
IQ Energy Sentinel™	V3-T9-112
PM3 Monitoring and Metering Module	V3-T9-121
Current Transformers (CTs)	V3-T9-122
Clamp-On Current Transformers	V3-T9-131
IQ Flange	V3-T9-134
Panel Mounting Adapter Kit	V3-T9-135
Enclosed Meters	V3-T9-136



Power Xpert Meter 4000/6000/8000 Series

Product Description

The Power Xpert Meter 4000/6000/8000 Series monitors the critical aspects of an electrical distribution system. This premier power quality metering instrument is simple to use, powerful, scalable and highly flexible.

The Power Xpert Meter 4000/6000/8000 offers a new level of intuitive user interface design, presenting critical electrical distribution system information in simple-to-navigate and easy-to-understand information architecture. The Power Xpert Meter 4000/6000/8000 graphic display visualizes the information from up to 16 meter modules. The embedded Web server displays complex power quality data using standard Internet browsers and allows for device configuration from the browser.

Both the local graphic display and the embedded Web server present real time, historical and event information in a browser-style graphical format to help the user interpret key circuit information, such as:

- Current loading
- Voltage and power levels
- Power factor
- Energy usage
- I/O status
- Power quality measurements
- Harmonic plots
- Disturbance and transient waveforms
- ITIC disturbance summary screen

The Power Xpert Meter 4000/6000/8000 graphic display uses a simple “twist and click” navigation control dial to easily navigate the menus and drill down into increasing levels of important detail. A “back” key enhances the browser-like navigation of the graphic display.

The Web server provides the energy and demand readings required to help manage the cost of energy. It also provides critical information regarding power quality, such as harmonic distortion, flicker, crest factor, K-factor and more.

Note: Features and functionality may vary depending on the meter model and options being used. Review the Features and Benefits chart on **Page V3-T9-35** for details.

Standards and Certifications

- Safety: EN61010-1, UL/cUL 61010-1
- Accuracy: IEC/EN60687 0.2 Class, ANSI C12.20 0.2 Class
- EMC: FCC Part 15 Subpart B Class A EN55011 Class A
- Measurement Canada Approval No. AE-1898 (4000/6000 meters)
- Immunity IEC 61326
- CE Mark



Application Description

Identify Power Quality Problems to Help:

- Identify harmonics, sags, swells and transients damaging or disrupting sensitive, mission-critical IT equipment
- Boost IT equipment’s service life to the maximum
- Analyze sequence of events up to 1 millisecond time resolution
- Protect motors from damage
- Preserve the integrity of processes and batches
- Prevent blown capacitor bank fuses
- Protect transformers and conductors from overheating

Detect and Record High-Speed Transients to Help:

- Avoid equipment damage and disruption
- Identify equipment malfunction

Monitor Circuit Loading to Help:

- Avoid overloads and nuisance overload trips
- Maximize equipment utilization
- Manage emergency overloads

Manage Energy Utilization to Help:

- Reduce peak demand charges and power factor penalties
- Identify excessive energy consumption

Metered/Monitored Parameters

Note: See **Page V3-T9-35**.

- Volts: L-L, L-N, Avg. L-L, Avg. L-N, N-G
- Phase neutral and ground currents
- Power: real, reactive and apparent
- Frequency
- Power factor: apparent and displacement
- Energy
- Demand
- % THD

- Minimum and maximum values
- Harmonics
- Flicker
- Individual harmonics
- Interharmonics
- % TDD
- ITIC events plot, duration, magnitude
- Energy comparisons
- Demand comparisons
- Event calendar
- Event timeline and sequence
- Number of 9s of availability
- Phasors
- Sequence components
- Crest factor
- K-factor
- PQ Index

Accuracy

- Currents: 0.05% RV + 0.025% FS
- Voltage: 0.1% RV + 0.025% FS
- Energy and demand power: 0.2% in accordance with ANSI C12.20
- Frequency: ±0.01 Hertz
- Power factor:
 - 0.10% at Unity PF
 - 0.30% at 0.5 PF

Communications

Multiple communications ports including:

Standard

- RS-485 remote display port
- RS-485 Modbus RTU slave port
- RJ-45 10/100Base-T local configuration port (local Web server connection)
- HTTP (local), FTP, COMTRADE

Optional

- Communications Expansion Card (CEC)
 - Selectable 100FX or 10/100Base-T Ethernet network port
 - RS-485 Modbus RTU selectable master/slave port
 - RS-232 Modbus RTU slave port

For Optional Graphic Display

Note: Display ports provide access to up to 16 Power Xpert 4000/6000/8000 Meter modules located on the display RS-485 network.

- RS-485 meter display network port
- RJ-45 10/100Base-T for access to Local Display Power Xpert network

Communication Protocols Supported

- Modbus RTU
- Modbus TCP
- Ethernet TCP/IP
- HTML
- NTP (Network Time Protocol)
- FTP (File Transfer Protocol)
- SMTP (Simple Mail Transfer Protocol)
- SNMP (Simple Network Management Protocol)
- COMTRADE (IEEE C37.111-1999)
- DNP 3.0 over Ethernet (Distributed Network Protocol)

Physical Characteristics

Two-Piece Design

- Power Xpert 4000/6000/8000 Meter modules
- Power Xpert Meter 4000/6000/8000 Graphic Display 320 x 240 pixel backlight LCD remote graphics display (supports up to 16 Power Xpert 4000/6000/8000 Meter modules)

Display/Meter Mounting Options

- Display remotely mounted up to 2000 ft (1219m) away from up to 16 Power Xpert Meter modules
- Display and Power Xpert Meter modules mounted together on opposite sides of a panel (15 additional meter modules can still be remotely mounted).

Meter Base Unit Characteristics

- NEMA rating: NEMA 1, IP30

Display Unit Characteristics

- NEMA rating: NEMA 12, IP42 front of panel rating

Ease of Use—Power Xpert Meter 4000/6000/8000 Graphic Display (Option)

The Power Xpert Meter 4000/6000/8000 display features a large easy-to-read white backlit graphic LCD. The information presented by the display is organized into an information architecture that is easy-to-navigate and organized for simplicity. Screen navigation is accomplished using a navigation control dial and a “back” button. The user simply twists the knob on the navigation control dial to move between menu selections and drill down links on the screen. When the selection is highlighted, pressing the dial makes the selection. Information is displayed from a single meter or an RS-485 daisychain of up to 16 meters. The display features a rich set of screens including real-time data, trend plots, waveform views and an ITIC Plot. The graphic display allows basic device setup and password protected resets. An audible alarm is available to annunciate alarm conditions.

Power Xpert Meter 4000/6000/8000 Embedded Web Server

The Power Xpert Meter 4000/6000/8000 embedded Web server offers Eaton customers a new level of accessibility to the critical information required to manage their electrical distribution system. The Web server includes real-time circuit information in both numeric and graphical visual formats to help monitor circuit parameters such as current loading, voltage and power levels, power factor, THD, Flicker and more. The Web server also provides energy and demand readings with graphic usage plots to help analyze energy usage patterns. Energy readings include kWh, kVARh, delivered and received and kVAh with time of use and RTP displays. The interval energy usage plot includes the ability to do week-to-week and month-to-month energy consumption graphical comparisons for benchmarking purposes. The embedded Web server will also display in simplified Chinese if connected to a computer configured for Chinese language.

Both the Power Xpert Meter 4000/6000/8000 embedded Web server and the local graphic display support graphical trend charts of key circuit measurements such as current, voltage, power and energy. The trend chart supports a zoom feature that allows the user to view data over a short period of 16 hours up to 4 years. The trend chart includes zoom in/out buttons and a horizontal slider bar control to manage scrolling forward and backward through the data. Trend charts of basic readings include minimum, maximum and average readings. Trend charts of interval by interval energy data also display peak demand.

Note: For remote access and networking capabilities such as connecting to a LAN/WAN, use the optional Communications Expansion Card (CEC).

Sag/Swell/Transient Capture and Recording

60 cycles of waveform are oversampled at 4096 samples per cycle (Power Xpert Meter 4000/6000), filtered through anti-aliasing and recorded at 512 samples per cycle and post event data. The Power Xpert Meter 8000 samples at a rate of 100,000 samples per cycle. Embedded Web server supports viewing of triggered waveforms one channel at a time and includes the ability to zoom and to scroll horizontally using a slider bar.

The Power Xpert Meter 6000/8000 Series have preconfigured (600 volts and below) trigger settings for sags, swells and transients, and do not require additional setup by the user. Waveforms are stored in non-volatile flash memory using an industry standard COMTRADE format. Waveforms can be automatically sent out as COMTRADE attachments to an e-mail following an event, or can be retrieved from an FTP (File Transfer Protocol) directory structure in the Power Xpert meter module's memory.

Historical Trend Logging

The Power Xpert Meter 4000/6000/8000 records historical data for graphical viewing from the Local display or the embedded Web server. Graphical views of historical data support pan and zoom. 145 standard metering parameters are logged as part of the standard meter functionality including min./max. and average for each parameter. The averages are calculated over the interval period. The minimum and maximum readings are based on 200 ms calculations.

Storage capacity for standard trend plots includes all of the following intervals:

- Every 5 minutes for 48 hours (2 days)
- Every 15 minutes for 192 hours (4 days)
- Every hour for 28 days (4 weeks)
- Every 8 hours for 56 weeks
- Every week for 44 months

Note: Trend plot data can be easily exported to third-party applications, such as Microsoft Excel in csv-file format.

In addition, metered parameters are automatically stored on the built-in FTP Servers, where they can be easily copied and imported into third-party applications for benchmarking and analysis. Logs on the FTP Server include the min./max. and average for 145 standard metering parameters at 5-minute intervals.

Storage capacity for trend data:

- 6 days of 5-minute interval trend data
- Capacity=18,144 intervals

Energy Profile Data

The Power Xpert Meter 4000/6000/8000 records Real and Reactive energy forward, reverse, net and absolute sum, as well as Apparent energy (kVAH). Up to 8 status inputs can be configured as energy accumulators for counting KYZ pulse inputs (option). These readings are stored over a configurable interval from 1 to 60 minutes, as well as in daily and weekly totals.

With the optional LAN/WAN Ethernet Communication Expansion Card (CEC), users can easily configure the meters to send periodic e-mails at user-defined intervals of energy consumption and power demand. E-mails contain a summary of readings per rate structures and also have the actual measurements attached to the E-mail's body as a CSV file in a ZIP container.

In addition, metered parameters are automatically stored on the built-in FTP Server, where they can be easily copied and imported into third-party applications for benchmarking and analysis. Logs on the FTP Server include energy consumption logs, one for every month in CSV file format, trended measurement logs also in CSV file format and waveform captures in COMTRADE file format.

Storage capacity for energy profile data:

- 62 days of 15 minute interval energy and pulse interval data.
- Fixed interval capacity = 5952 intervals. Configurable intervals from 1 to 60 min
- 372 days of 1 day accumulated energy and pulse interval data
- 208 weeks of 1 week accumulated energy and pulse interval data

Energy and Demand Comparisons

Energy and demand usage patterns can be analyzed with the month-to-month, week-to-week comparison chart built into the meter. Raw data can be exported with the "Save Table" option to other applications, such as Excel, for further analysis and graphing.

Power Xpert Meter Profiler—Free Download

The Power Xpert Meter Profiler software allows you to compare “expected” energy consumption patterns to present usage and flag

areas of concern. It is also a predictor. It can predict what energy consumption would be expected later in a day.

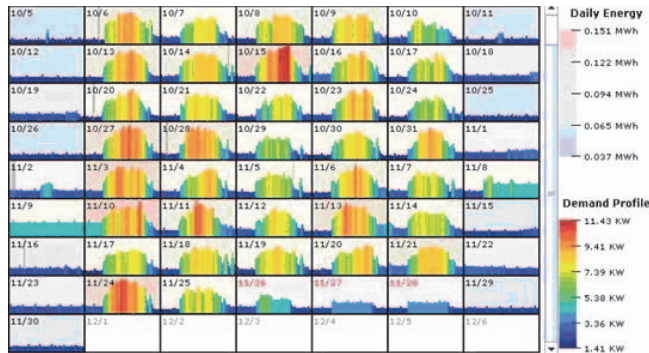

Event Triggers

The Power Xpert Meter 4000/6000/8000 supports five types of configurable event triggers:

- Out of limits (4000/6000/8000)
- Demand overload (4000/6000/8000)
- Sub-cycle disturbance (4000/6000/8000)
- ITIC (6000/8000)
- Fast transient (8000)

These triggers permit pickup, reset and pickup delay to be configured by the user. When a trigger occurs, actions include Performance Monitoring (#9’s analysis), Capturing Waveform, Capture Parameters, Send Email and Operate a Relay Output. The Graphic Display flashes an LED to annunciate the alarm condition. An audible alarm is also available.

Trigger options include:

- Out of limits: over 100 triggers
- Demand overload: 10 triggers
- ITIC: 8 triggers
- Fast transient: dV/dT and absolute per phase
- Sub-cycle disturbance—dV/dt and absolute

Event Logging

The optional Power Xpert Meter 4000/6000/8000 Local graphic display or the embedded Web server both allow the user to view a list of triggered events along with any captured parameters, event details and triggered waveforms. In addition, a separate event log includes a variety of activities including acknowledged triggers, new min. and max. events, and system operations such as resets. The size of the event log is virtually unlimited based only on the memory option selected.

E-mail Notification

With the optional LAN/WAN Ethernet Communication Expansion Card (CEC) attached to the Power Xpert Meter 4000/6000/8000’s, the users can easily configure the meters to send periodic emails at user-defined intervals for energy consumption and power demand. Emails contain a summary of readings per rate structures and also have the actual measurements attached to the email’s body as a CSV file in a ZIP container. Prompt alarm emails can also be sent for any event condition either standard in the meter or ones set up by the user based on thresholds, dV/dt triggers or IO status changes with the optional IO Card. Alarm emails can be configured to have the COMTRADE waveform capture attached to the e-mail’s body.



Periodic Email Message

ITIC Analysis Plot

The Power Xpert Meter graphic display (option) and Web server include a graphic representation of the ITIC plot (Power Xpert Meter 6000/8000) with counts of disturbances and transients that have occurred. The ITIC plot organizes events into 8 distinct disturbance zones corresponding to severity and a 9th zone for transients. A pass/fail count is displayed to indicate how many events are outside the ITIC limits. Clicking on any counter in the ITIC Web page will link the user to the event view and display all triggered events in the selected zone.

This makes it simple to view disturbance waveforms associated with the ITIC plot.

A separate ITIC graph is available to review individual ITIC events. This graph will show the user the event hit position on the graph and the event duration and magnitude.

Inputs and Outputs

Power Xpert Meter 4000/6000/8000 is available with an optional digital I/O card, which includes:

- Eight digital inputs—self sourced 24 Vdc

- Three relay outputs—5A max. continuous, 240 Vac max., 30 Vdc max.
- Two solid-state outputs—80 mA max. continuous, 30 Vdc max.

Each of the 8 inputs are interrupt driven, allowing for 1 ms accuracy of digital events time stamps (1 ms accuracy requires local NTP TimeServer). Inputs can also be configured for demand synch and pulse counting. Inputs selected for pulse counting can be scaled. Interval by interval pulse recordings are maintained in profile memory and can be

displayed graphically. Outputs can be used for KYZ, or alarm annunciation.

Ratings

- Application to 500 kV, no PTs to 600V
- CT ratios selectable from standard 120/600 Vac line
- CT inputs accept 5A secondary
- Power supply:
 - Standard 120/240 Vac or 110/250 Vdc

Storage Capacity

Power Xpert Meter 4000/6000/8000 Estimated Memory and Storage Capacity with 2/4/8 GB Memory Capacity

Model	Memory	Event	File Size (KB)	Occurrence Per Month ^①		Memory Usage (MB)		Months of Capacity ^②	
				Typical	Severe	Typical	Severe	Typical	Severe
PXM 4000	2 GB	Subcycle Disturbance	1260	10	60	12.3	73.8	166	28
PXM 6000	4 GB	ITIC Event	1260	5	20	6.2	24.6	666	166
		Subcycle Disturbance	1260	10	60	12.3	73.8	333	55
		ITIC + Subcycle Disturbance	Total--->	15	80	18.5	98.4	222	42
PXM 8000	8 GB	ITIC Event	1260	5	20	6.2	24.6	1332	333
		Subcycle Disturbance	1260	10	60	12.3	73.8	666	111
		Transients	2048	3	30	6.0	60.0	1365	137
		ITIC + Subcycle Disturbance + Transients	Total--->	18	110	24.5	158.4	335	52

Notes

- ① The typical and server power quality event occurrences are estimates and may vary depending on the electrical environment.
- ② Memory is not allocated by event category; memory is used first come, first served.

Features and Benefits

Power Xpert Meter 4000

- Harmonics, including individual harmonics
- Disturbance capture
- Low frequency transient detection and capture
- Standard power quality index

Power Xpert Meter 6000

- Interharmonics
- Flicker calculations
- ITIC performance curve
- Event calendar view
- Events timeline view
- Sequence of events waveform plot
- Enhanced power quality index

Power Xpert Meter 8000

- Impulsive transient capture at 6 MHz
- 100,000 samples per cycle
- Premium power quality index

Power Xpert Meter 4000/6000/8000

Feature	Power Xpert Meter			Benefit
	4000	6000	8000	
General				
Embedded Web server	■	■	■	Use a standard Web browser to monitor and manage the meter over the network, Internet
TOU metering support	■	■	■	Time of usage can be set up to support 4 different schedules
Firmware flash update support	■	■	■	Enables you to flash the meter with the latest firmware updates
Self-learning capability (characterizes “normal” per circuit)	■	■	■	The meter can automatically adjust to the environment and alarm only when “real” events occur
Power, Energy and Demand				
Voltage, current: per phase minimum, maximum, average, trend graph analysis, export, print	■	■	■	Review voltage and current trends, export, print and analyze parameters right on the meter or external software
Energy and demand plot comparisons month-to-month, week-to-week	■	■	■	Plot two months or two weeks for vivid energy or demand comparison
Power: power factor, apparent, real, reactive, frequency	■	■	■	Review power usage and power factor and avoid potential PF penalties
Energy, demand: forward, reverse, net, sum, tou, profile, previous month comparison, graph analysis, export, print	■	■	■	Keep track of your energy usage, compare time of usage and usage against previous month, identify peaks to conserve energy usage
Power Quality Analysis				
Statistical analysis (min., max., average)	■	■	■	Review statistical trends, identify past and future problem areas
Sag and swell monitoring, management and recording	■	■	■	Capture electrical sags and swells and analyze the waveforms
Symmetrical Components: Zero, Negative, Positive	■	■	■	Analyze possibly unbalanced three-phase power systems
Low frequency transient detection and capture	■	■	■	Capture lower frequency transient waveforms for retrospective analysis or e-mailing
Sampling rate, maximum samples/cycle	4096 ①	4096 ①	100,000	Extremely high sampling rate will effectively capture impulsive transients
“Number of Nines” uptime data (e.g., 6 nines = 99.9999%)	■	■	■	Review uptime availability per cent
K-factor	■	■	■	Review the ratio of eddy current losses, e.g., when driving nonlinear and linear loads
Crest factor	■	■	■	Review the peak-to-average ratio of the waveform
Security				
Secure 5 level user access privileges	■	■	■	Define appropriate security access level per user
Communications and I/O				
Modbus TCP	■	■	■	Easy integration with standard protocol to power management and other software
Modbus RTU	■	■	■	Integrate meters to existing Modbus networks, daisy chain several (1–16) meters together
HTML	■	■	■	Communicate to the meter over the Internet via standard Web browser
SNMP (simple network management protocol)	■	■	■	Communicate with the meter via Simple Network Protocol; hook to existing NMS system
SMTP (simple mail transfer protocol)	■	■	■	Send e-mail messages via standard Simple Mail Transfer Protocol
FTP (file transfer protocol)	■	■	■	Access, copy, paste, cut waveform capture files on the meter with an FTP Client
NTP (network time protocol)	■	■	■	Network Time Protocol support enables the meter to synchronize time over the network up to the 1 millisecond resolution
COMTRADE, open IEEE Standard file format for Waveform capture export	■	■	■	Import waveform captures in standard IEEE (C37.111-1999) COMTRADE file format to third-party software
DNP 3.0 over Ethernet (Distributed Network Protocol)	■	■	■	Communicate with the meter via DNP 3.0 over Ethernet; hook to existing utility systems

Notes

These specifications are subject to change without notice and represent the maximum capabilities of the product with all options installed. This is not a complete feature list. Features and functionality may vary depending on selected options, firmware version and product model. Please refer to the technical data sheet and User Manual for detailed specifications.

① Delta-Sigma A/D oversampling rate.

Power Xpert Meter 4000/6000/8000, continued

Feature	Power Xpert Meter			Benefit
	4000	6000	8000	
Communications and I/O, continued				
Trend measurements CSV file export	■	■	■	Easily export trend measurements to third-party applications, e.g., Microsoft Excel in standard CSV file format
I/O (8 digital inputs, 3 relay outputs, 2 solid-state KYZ outputs)	■	■	■	The Power Xpert I/O Card is extremely flexible and can be used in a large variety of different applications. Digital inputs and relay outputs can be programmed to interact during various conditions defined by the user. Various third-party devices, such as alarm, pulse meters, trip units, sensors can be easily integrated to the Power Xpert Meter. Triggers and events can be tied to the meters standard functions such as e-mail, logs and trends
Time Synchronization				
NTP time synchronization up to 1 millisecond accuracy	■	■	■	Network Time Protocol support enables the meter to synchronize time over the network up to the 1 millisecond resolution
GPS time synchronization up to 1 millisecond accuracy	■ ^①	■ ^①	■ ^①	The GPS option allows the meter to synchronize time over the GPS satellite positioning system up to the 1 millisecond resolution
Logs				
Trend logging	■	■	■	Log trend information for easy statistical analysis
Load profile	■	■	■	Review the load profile graph to get a better understanding of your electrical load versus time
Event logging	■	■	■	Log events for retrospective event analysis
Memory and Storage				
Standard memory, GB	2	4	8	Store large amounts of waveform captures and events for historical analysis
Harmonics				
Harmonic levels	127	127	127	Provides extremely fast, high resolution D/A conversion
Total harmonic distortion (THD)	■	■	■	Review the total harmonic distortion level directly on the meter
Delta-Sigma D/A conversion technology	■	■	■	Provides extremely fast, high resolution D/A conversion
Harmonics over-sampling (4096 samples per cycle)	■	■	■	Over-sampling enables the usage of Anti-Aliasing technology, increasing accuracy
Anti-alias filtering	■	■	■	Technology to remove out-of-band signal components resulting in more accurate data
Individual harmonics	■	■	■	Review individual harmonic levels directly on the meter
Total demand distortion (TDD)	■	■	■	Identify harmful harmonics in e.g. lightly loaded variable-speed drive environments where THD may be high but not relative
Interharmonics		■	■	Interharmonics allow you to see what is going on between the integer multiples of the fundamental. Zoom in on the harmonics trend graph and review frequency content every 5 Hz instead of every 60 Hz
Highlights				
Sub-cycle disturbance capturing	■	■	■	Capture fast voltage changes/low frequency transient (e.g. capacitor switching transient)
dV/dt triggers for sub-cycle oscillatory transients	■	■	■	Detect and record a large magnitude oscillation transient resulting in equipment damage
Absolute threshold and dV/dt triggering	■	■	■	Detect and record if a surge suppressor is necessary
Power quality index—standard (includes dv/dt count, %TDDi and %THDv)	■	■	■	Complex power quality data put into simple graphic format
Power quality index—enhanced (includes Standard Index plus Sag level, Swell level and Flicker)		■	■	Complex power quality data put into simple graphic format (includes ITIC events and flicker calculations)
Flicker calculations		■	■	Detect and quantify low frequency rms voltage variations causing incandescent lighting flicker
Automatic trigger setting		■	■	Trigger thresholds are automatically set according to ITIC (CBEMA) standard, no need to figure this out by yourself
Automatic event severity analysis		■	■	Automatically analyze the severity of the event with the ITIC (CBEMA) performance curve plot, see where the event actually hit

Notes

These specifications are subject to change without notice and represent the maximum capabilities of the product with all options installed. This is not a complete feature list. Features and functionality may vary depending on selected options, firmware version and product model. Please refer to the technical data sheet and User Manual for detailed specifications.

① When used with third-party device and I/O option.

Power Xpert Meter 4000/6000/8000, continued

Feature	Power Xpert Meter			Benefit
	4000	6000	8000	
Highlights, continued				
Event severity counters		■	■	An ITIC (CBEMA) event counter keeps track of the number of all sags, swells and transients
ITIC (Information Technology Industry Council), previously CBEMA performance curve		■	■	ITIC (Information Technology Industry Council), previously CBEMA performance curve for easy power problem evaluation
Custom ITIC (CBEMA) plot with individual event magnitude and duration		■	■	Review custom ITIC (CBEMA) plots of individual events showing you the actual magnitude, duration and hit are in a simple graphical representation
Event calendar view		■	■	The Events Timeline calendar view provides instant insight to the frequency of power events and helps detect reoccurring problems
Events timeline view		■	■	View and understand the sequence of events that have occurred during a period of time
Sequence of events and events plot on waveform		■	■	Plot color-coded events on a captured waveform to gain insight into the sequence of events cycle per cycle
Power quality index—premium (at-a-glance “thermometer” view of power quality)			■	Complex power quality data put into simple graphic format (includes ITIC events and flicker calculations)
High-Speed Transient Capture and Detection				
6 MHz capture of impulsive transients			■	Capture impulsive transients by taking 6 samples every millionth of a second
Transient Capture Duration: ~20 ms/6 MHz ~120 ms/1 MHz			■	Record and analyze transients during a longer timeframe
Waveform recorded at 100,000 samples per cycle			■	High-speed ensures impulsive transients are correctly captured (fast rise time)
Three-phase voltage and neutral-to-ground fast transient capture			■	Capture impulsive transients on all 4 channels

Notes

These specifications are subject to change without notice and represent the maximum capabilities of the product with all options installed. This is not a complete feature list. Features and functionality may vary depending on selected options, firmware version and product model. Please refer to the technical data sheet and User Manual for detailed specifications.

Power Xpert 4000/6000/8000 Graphic Display (Option) Features

A menu-driven graphical display with information organized into a user-friendly information architecture.

The homepage (see below) offers:

- Graphical level indicator based on a statistical analysis for three-phase line-to-line and line-to-neutral voltage and per phase currents to quickly indicate out of normal readings
- Large easy-to-read average L-L voltage average phase currents and system frequency can be highlighted and selected using the navigation control dial to drill down for additional detail
- Menu selections for meter, power, quality, events and setup are shown for ease of navigation into display for more detail, or basic device setup

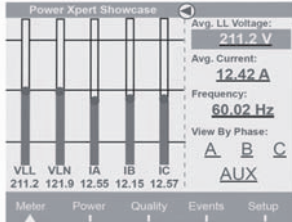

Homepage

Highlighting a field such as the avg. current value and pressing the navigation control dial brings up a detail screen like the one below.

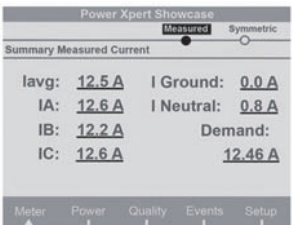

Current Summary

Highlighting an individual reading on the detail summary level screen and selecting it drills down to a level including links to min./max., historical trend plots, triggers, harmonic spectral data and waveform viewing. Selecting the trend plot for a given parameter displays a historical graph of the selected parameter over the last 16 hours. The zoom buttons change the time scale to one of several data views based on historical averages with min./max. The Pan button allows scrolling within the selected view.

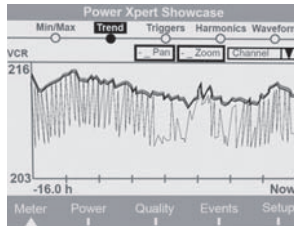

Trend Plot

Waveforms can be displayed for currents and voltages. The waveforms can be viewed on demand for steady-state conditions. Triggered waveforms can also be displayed to view sag/swell or transient data.

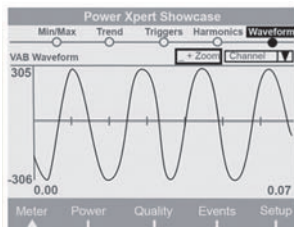

Waveform Viewer

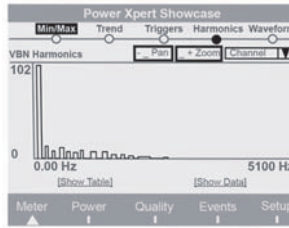

Harmonic Spectrum

The harmonic spectral plot displays both harmonics and interharmonics up to the 85th order. A detailed table also includes individual magnitudes and angles of current and voltage harmonics, as well as a harmonic power calculation at each frequency.

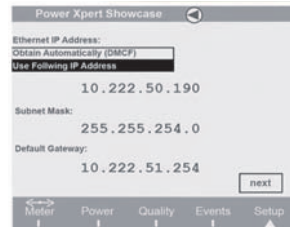

Ethernet Settings

Ethernet and other settings can be input or verified via the Power Xpert Meter LCD display.

Note: Some of the other settings are specific only to the Web Browser GUI.

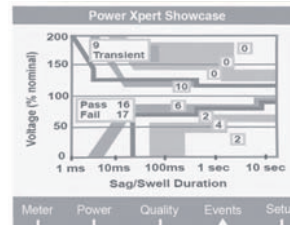

ITIC Plot (Power Xpert 6000/8000)

The Power Xpert Meter classifies disturbances and summarizes the results graphically using the ITIC plot. The number of ITIC sags and swells are indicated for each of nine severity levels. A pass/fail summary is shown to indicate how many events are outside the ITIC pass zone.

Power Xpert Graphic Display (Option) Screens

Meter Top Level Screen

V-LL avg, V-LN avg, IA, IB, IC, lavg, freq.

Meter Detail Screens

Per phase detail L-L, L-N, Symmetrical Comp, Aux. Channels, Min./Max. with date/time of occurrence, Trend Plots, Triggers, Phasors.

Power Top Level Screen

Three-Phase Power Factor, kWhr, kWd, Real-Time kW, kVAR, kVA, Load Profile Link.

Power Detail Screens

Per phase detail, kVA, kVAR, kW, Min./Max. with date/time of occurrence, Trend Plots, Triggers.

Quality Top Level Screen

10 min. and 24 hr. PQIndex, THDI, THDV, K-factor, Crest Factor, Flicker Pst, %9's of Reliability.

Quality Detail Screens

Per phase detail L-L, L-N, V aux, Odd, Even, Interharmonics, Present, Min/Max, Trend Plots, Harmonic spectrum plots, waveform plots.

Events Top Level Screen

Active/Acknowledged Event list, Trigger List, System Log, ITIC Curve Link.

Event Detail Screens

Event List, Condition, Acknowledge Button, Trigger Date/Time, Trigger description.

Setup Top Level Screen

View setup, Edit setup, Login, Logout.

Setup Detail Screens

Quick Setup, Trigger setup, Detail setting.

Power Xpert 4000/6000/8000 Web Browser Views



Power Xpert 4000/6000/8000 Web Browser Homepage (Note: 4000 does not include flicker, ITIC)

Power Xpert Meter 4000/6000/8000's embedded Web server offers Eaton customers a new level of accessibility to the critical information required to manage the electrical distribution system. The embedded Web server includes real-time circuit information in both numeric and graphical formats to help monitor circuit parameters such as current loading, voltage and power levels, power factor.

The Web server also provides the energy and demand readings required to help manage the cost of energy. Readings include kWh, kVARh, delivered and received and kVAh with time-of-use and separate status input controlled energy accumulation to account for energy during special times such as rate alert periods or stand-by generator times of operation.

The Web server also includes critical information regarding Power Quality such as harmonic distortion, flicker (Power Xpert Meter 6000/8000), crest factor, K-Factor and more.

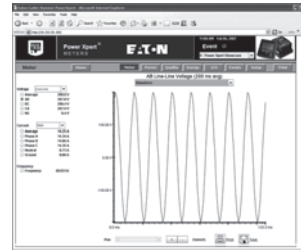

Steady-State Waveform

The Web server allows the user to view waveforms of the voltage and current to spot power quality problems such as notching.



Events Timeline (Power Xpert 6000/8000)

View and understand the sequence of events that have occurred during a period of time. Plot color-coded events on captured waveforms to gain insight into the sequence of events from one single cycle to the next one. This provides the user an excellent vantage point to review and compare multiple events at an unprecedented resolution.



Harmonic Spectral Plot

The harmonic spectral plot displays both harmonics and interharmonics up to the 85th order. A detailed table also includes individual magnitudes and angles of current and voltage harmonics, as well as a harmonic power calculation at each frequency. Even, odd and total THD are displayed for diagnostic purposes. In addition, the Power Xpert 6000/8000 provides interharmonics, which allow users to see what is going on between the integer multiples of the fundamental.



Historical Trend Plot

Graphical Trending of Data

The Power Xpert Meter 4000/6000/8000 embedded Web server supports graphical trend charts of key circuit measurements such as current, voltage, power and energy. The trend chart supports a zoom feature that allows the user to view data over a short period of 16 hours or a longer period of 48 months. The trend chart has a horizontal slider bar control to manage scrolling forward and backward through the data. Trend charts of basic readings include minimum, maximum and average readings. Trend charts of energy data also display demand values.



Energy Comparison

Energy usage patterns can be effortlessly analyzed with the month-to-month, week-to-week comparison chart. Raw data can be easily exported with the “Save Table” option to other applications such as Excel for further analysis or graphing (firmware version 12.x.x and higher only).

Note: All data logging for trend plotting is automatically preconfigured in all of the Power Xpert Meter 4000/6000/8000 meters. In addition, the 6000 and 8000 Series meters have sag, swell and transient triggers built-in according to the ITIC (CBEMA) standard.



Demand Comparison

Demand comparison compares power consumption day-to-day, month-to-month or week-to-week. Power Xpert Meters can set to measure demand at 1 to 60 minute intervals. Both sliding and fixed interval windows are supported for maximum flexibility.

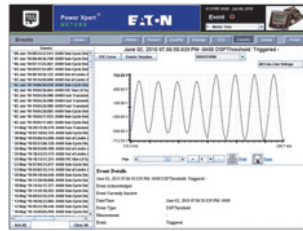

Disturbance Recording

Sag/Swell Recording

60 cycles of waveform are recorded at 256 samples per cycle including 30 cycles of pre- and post-trigger data. The Power Xpert Meter 4000/6000/8000 embedded Web server supports viewing of triggered waveforms one channel at a time including the ability to zoom and to scroll horizontally using a slider bar. Waveforms are stored in Power Xpert Meter’s 4000/6000/8000 non-volatile flash memory using an industry standard Comtrade format. Waveforms can be automatically sent out by e-mail following an event, or can be retrieved from an FTP directory structure in the meter module’s memory.

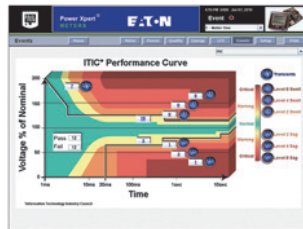

**ITIC Analysis Plot
(Power Xpert Meter 6000/8000)**

The ITIC Web page includes counters to track the occurrence of disturbances and a pass/fail summary. In addition, selecting any disturbance counter links to a detailed event view of the disturbances in that ITIC category. Disturbance waveforms can be viewed from the browser.



**Events Calendar
(Power Xpert 6000/8000)**

The Events Timeline calendar view provides instant insight to the frequency of power events and helps detect reoccurring problems. Color-coded events can be filtered to detect specific issues.



Configuration Page

Web Server Device Configuration

Special software is not required to configure a Power Xpert Meter 4000/6000/8000. The embedded Web server includes comprehensive device set-up capability.

Discrete Contact Inputs

The optional PXIO-B expansion card offers 8 digital inputs that are useful for a variety of applications such as:

- Status indication with time stamping of transitions (1 ms precision).
- Pulse counting of KYZ or other utility pulses such as air, water or gas.
- High-speed triggering of waveforms based on events such as breaker trips or static transfers
- Demand interval timing taken from a master utility meter end of interval pulse

Status inputs are self sourced providing a nominal 24 Vdc (20–30 Vdc) across the circuit.

Names can be configured for each input for ease of use.

Relay Outputs

The optional PXIO-B card includes three 5A form C relay outputs rated for 240 Vac or 30 Vdc. These outputs can be used for applications such as:

- Alarm annunciation
- KYZ pulse output

Alarm outputs can be driven from triggers based on metering values. Output modes include:

- Normal—relay energized during alarm condition
- Latched—relay energized by event trigger, de-energized by acknowledgement
- Timed—relay energized by event trigger, maintained for a programmed interval.

Communications Expansion Card (CEC)

The optional CEC Card offers two Ethernet connection options, 10/100Base-T and a fiber-optic port that can be used for the following applications:

- Monitoring, managing and configuring the meter remotely using a standard Web browser interface like Microsoft Internet Explorer
- Alarm notifications via e-mail, SMTP
- Enabling access to the meter’s FTP server (energy, trend and waveform logs)
- Providing Modbus TCP/IP or RTU communications to BMS systems
- Providing DNP 3.0 over Ethernet to utility systems
- Providing SNMP communications to NMS systems
- Synchronizing with an NTP server for 1ms timestamping resolution
- Asset management via SNMP to Network Management Systems
- Updating firmware on the meter

Flicker (EN61000-4-15; Power Xpert Meter 6000/8000)

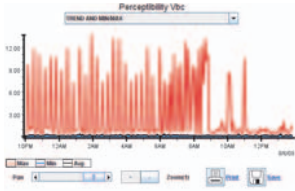

Flicker values for perceptibility, PST and PLT are calculated based on EN61000-4-15 guidelines.

Power at a Glance

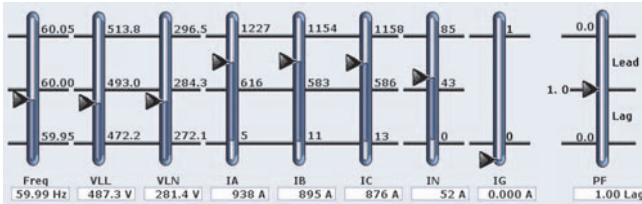

Easily Upgrade Your Power Xpert Meter 4000 to a 6000

Eaton understands that our customers' needs change over time. That's why we've developed meters that can grow with you. Once a Power Xpert Meter is purchased, you have the ability to upgrade to a Power Xpert Meter 6000, with no intervention from Eaton, when needed. All the features of the Power Xpert Meter 4000 that you have been using and depend on remain, however, once updated, all the additional features of the Power Xpert Meter 6000 are available. The self-upgrade is available on Eaton's website. You'll need a credit card, your Power Xpert Meter 4000 serial number and data code (you will be presented with this information if you are using the upgrade link directly from your Power Xpert Meter) and your e-mail address. Once you have completed the purchase, we will send you your new license key information via e-mail that will allow you to complete the upgrade.

Power Xpert Meter 4000/6000/8000 Module Layout

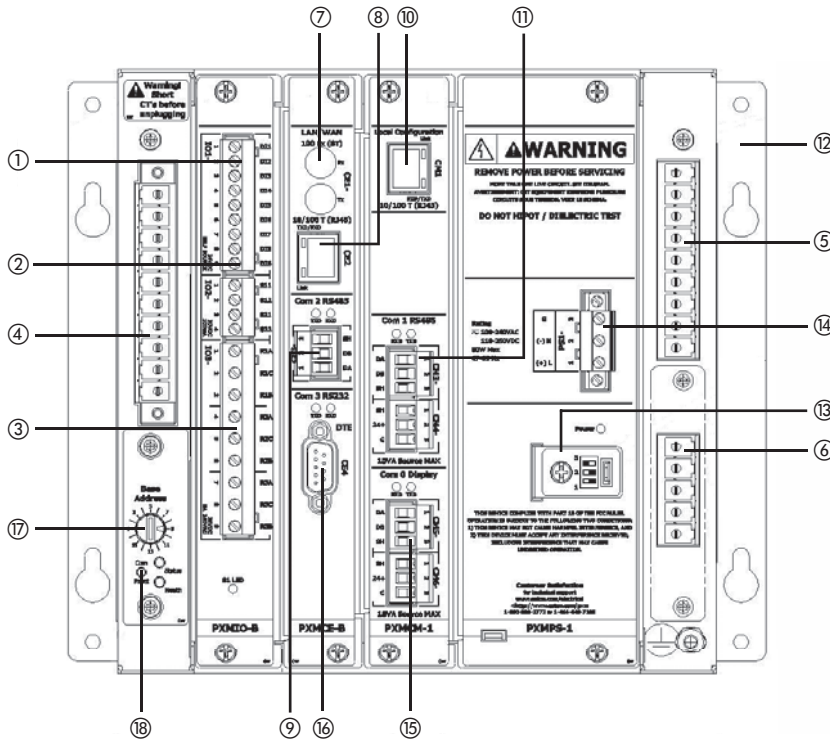

I/O Card

- ① Digital inputs 1–8 (option)
- ② Solid-state outputs 1–2 (option)
- ③ Relay outputs 1–3 (option)

CT and Voltage Connections

- ④ CT input connections
- ⑤ Standard three-phase voltage phase inputs
- ⑥ Aux. channel voltage inputs (option)

Communication Expansion Card (LAN/WAN Ethernet Networking)

- ⑦ 100FX ST-type Ethernet (multi-mode) (option)
- ⑧ 10/100Base-T Ethernet (option)
- ⑨ RS-485 (two-wire w/shield)—24V accessory power (com 2)

Standard Features

- ⑩ Local RJ-45 config. port (non-networkable Ethernet)
- ⑪ RS-485 (two-wire w/shield) Modbus RTU (com 1)
- ⑫ Meter mounting brackets
- ⑬ Sealable mode switch cover
- ⑭ Control power (100–240 Vac and 110–250 Vdc) ($\pm 20\%$)
- ⑮ Display RS-485 Network port (up to 15 meters)—24V accessory power (com 0)
- ⑯ RS-232 (Tx Rx) Modbus RTU (com 3) (option)
- ⑰ Meter base address
- ⑱ Com Reset Button

Catalog Number Selection

To order a Power Xpert Meter 4000/6000/8000, the catalog number should be determined using the chart shown below. The chart illustrates how to include the desired factory options as part of a catalog number. Option cards that are selected at time of order entry will be installed at the

factory. Option cards are also field installable for field upgrades.

If a display is required, it should be ordered separately. The multi-meter graphic display is capable of displaying data from an RS-485 daisychain of up to 16 Power Xpert Meter 4000/

6000/8000 modules over a distance of up to 1000 ft. Power Xpert Meter modules include panel mounting brackets. The multi-meter graphic display is designed to mount separately. If back-to-back meter to display panel mounting is desired, a mounting bracket kit is available (**PX-PMBA**).

Example 1: PXM8251A1BB (PXM 8000 Meter, w/ VAUX, Std. Pwr, Com. Exp. & I/O Cards)

Example 2: PXM6251A1BA (PXM 6000 Meter, w/ VAUX, Std. Pwr, Com. Exp. Card)

Power Xpert Meter 4000/6000/8000

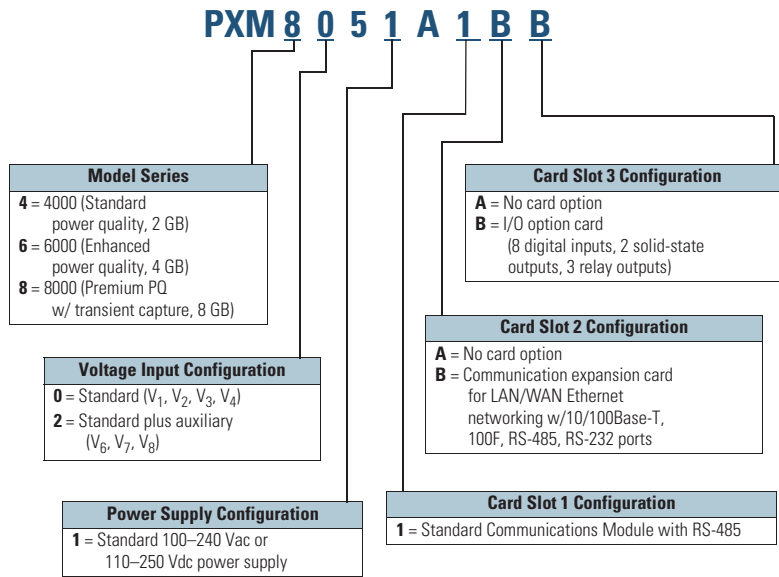

Example 1: **PXM8251A5BB** (PXM 8000 meter, w/ VAUX, std. pwr., com. exp. and I/O cards)
 Example 2: **PXM6251A6BA** (PXM 6000 meter, w/ VAUX, std. pwr., com. exp. card)

Accessories

Power Xpert Meter 4000/6000/8000

Description	Catalog Number
Graphic display module	PXD-MMG
Communication expansion card for LAN/WAN Ethernet networking: 100FX fiber-optic, 10/100T, RS-485, RS-232	PXMCE-B ①
Digital I/O card: eight digital input, two solid-state output, three relay output	PXMIO-B ①
Panel mounting bracket assembly for back-to-back meter to graphic display mounting	PX-PMBA
Panel mounting bracket assembly for retrofitting a graphic display to an IQ Analyzer cutout	PX-PMBB
Panel mounting bracket assembly for reduced graphic display rear clearance	PX-PMBC
Power Xpert Meter 4000 to 6000 license upgrade key	PXM-4KUPG

Notes

① These items can be ordered separately or preinstalled in the meter by selecting option B in the model number. Communication cable (standard Modbus RTU) is not included in the package for meter module connection.

Technical Data and Specifications**Environmental Conditions**

- Operating temperature:
 - Meter: -20 to +70°C
 - Display: -20 to +60°C operating
- Storage temperature: -40 to +85°C
- Operating humidity: 5% to 95% condensing
- Device weight: 7.1 lbs—meter 2.1 lbs—display
- Meter and back of display are pollution degree 2
- Elevation to 6562 ft (2000m)

Current Inputs (Each Channel)

- Conversion: 4096 samples per cycle delta-sigma converter digitally filtered down to 512 samples per cycle
- CT Input: 4096 rms samples per cycle delta-sigma converter digitally filtered down to 512 samples per cycle for anti-aliasing
- Burden: less than 10 milliohms
- Overload withstand: 500A for 1 second, non-repeating
- Range: 0.005–20A continuous
- Accuracy: 0.05% or reading plus 0.01% of full scale (from 50 milliamps to 20A)

Voltage Inputs (Each Channel)

- Conversion: 4096 rms samples per cycle delta-sigma converter digitally filtered down to 512 samples per cycle for anti-aliasing
- PT input: 120V–500,000V primary
- Input range: 600V L-L, 347 L-N direct connect
- Nominal full scale: 1000V rms
- Input impedance: 2 megohms

Frequency Range

- 47–63 Hz

Harmonic Response (Voltage, Current)

- 127th harmonic

Accuracy

- ANSI C12.20 0.2 Class
- IEC 687 0.2 Class

Discrete Inputs

- Self sourced: 24 Vdc

Relay Output Contacts

- 5A maximum, 240 Vac maximum, 30 Vdc maximum
- Lifetime: 1,000,000 no load operations
- 100,000 under rated voltage and load

Solid-State Outputs

- Maximum load: 100 milliamps
- Maximum voltage: 30V (externally sourced)

Control Power Input

- Input range AC: 100–240 Vac ($\pm 20\%$)
- Frequency range: 47–63 Hz
- Input range DC: 110–250 Vdc $\pm 20\%$
- Burden 50 VA
- Ride-through: 1–5s

Wiring Diagrams

Three-Phase, Three-Wire Delta (Up to 600 Volts)

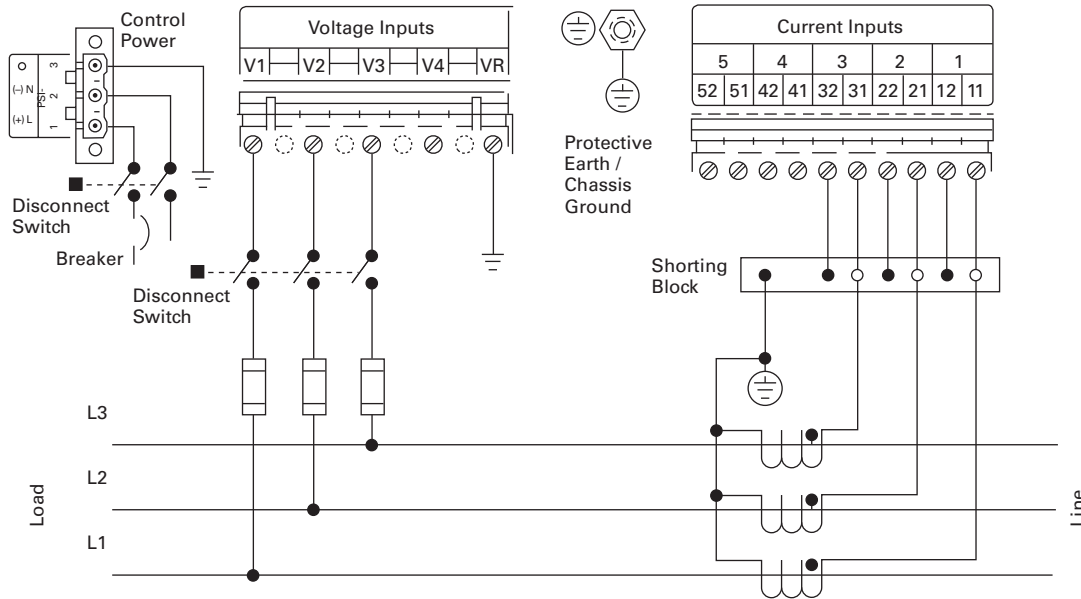

Three-Phase, Three-Wire Delta (Above 600 Volts)

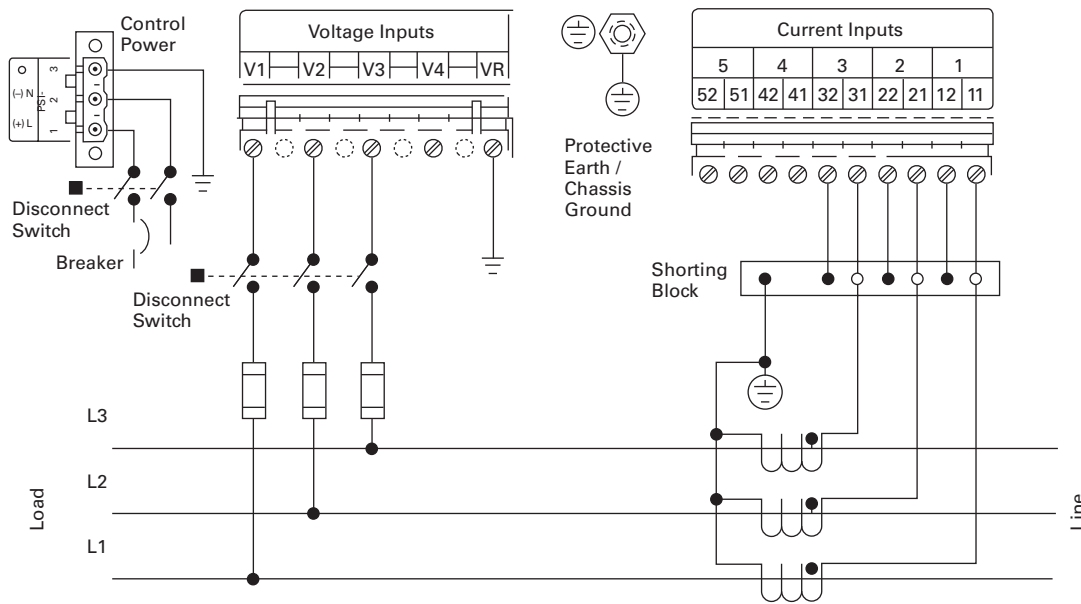

Note

Based upon the voltage rating, you may need a control power transformer for the control power.

Power Xpert Meters Configuration and Wiring Examples

Display Link

Up to 16 Meters can be Daisy-Chained to a Single Power Xpert Meter LCD Display

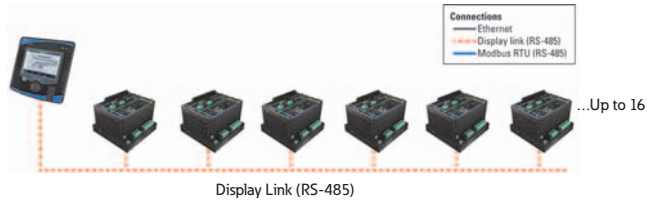

Modbus RTU (RS-485) – Non-Web Enabled

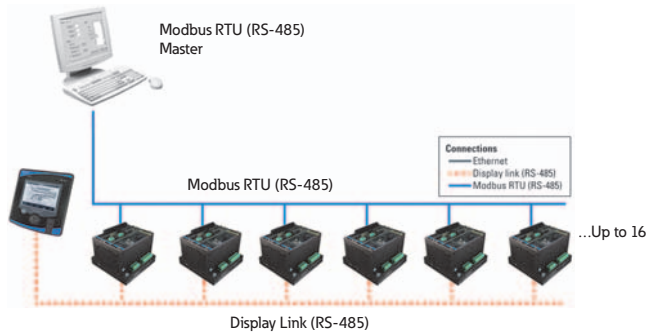

Web Enabled – Browser and Modbus TCP

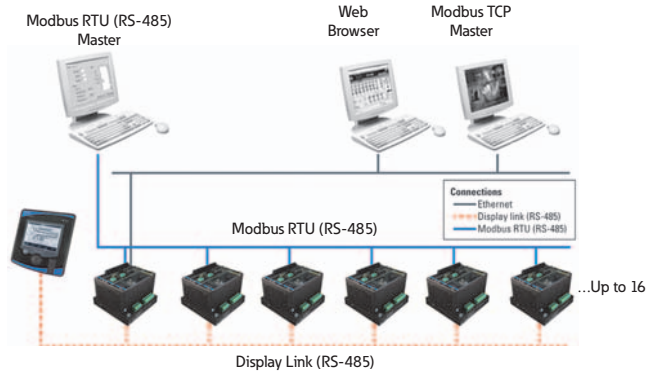

Web Enabled – Advanced System Functionality

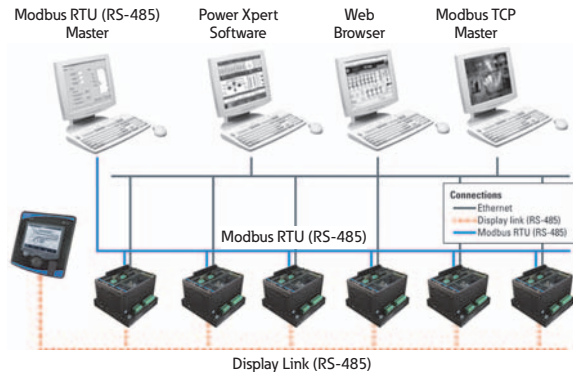

Accessories—I/O Card (Option)

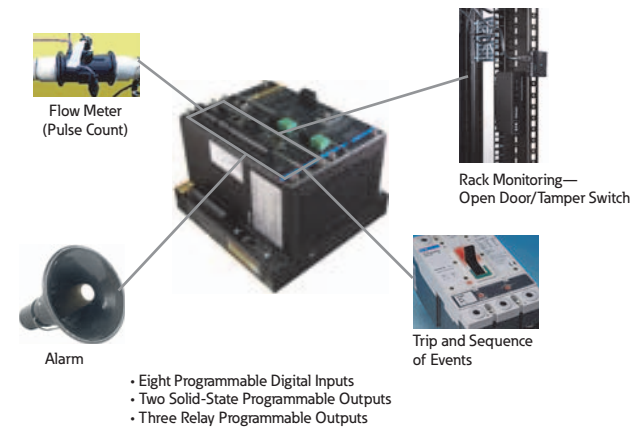

IT Configuration Examples—Accessories—I/O Card (Option)

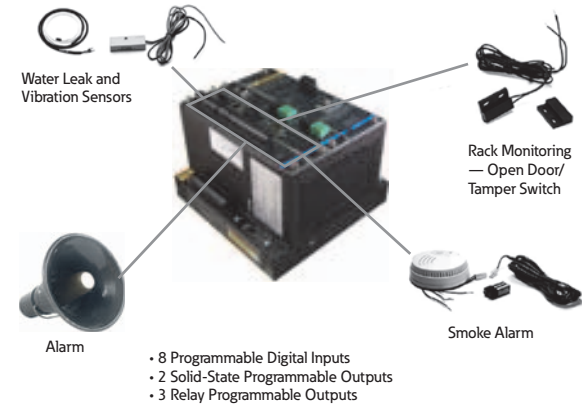

Dimensions

Approximate Dimensions in Inches (mm)

Power Xpert Meter 4000/6000/8000 Multimeter Graphic Display (PXD-MMG)—Sold Separately, Supports up to 16 Power Xpert Meter 4000/6000/8000 Modules

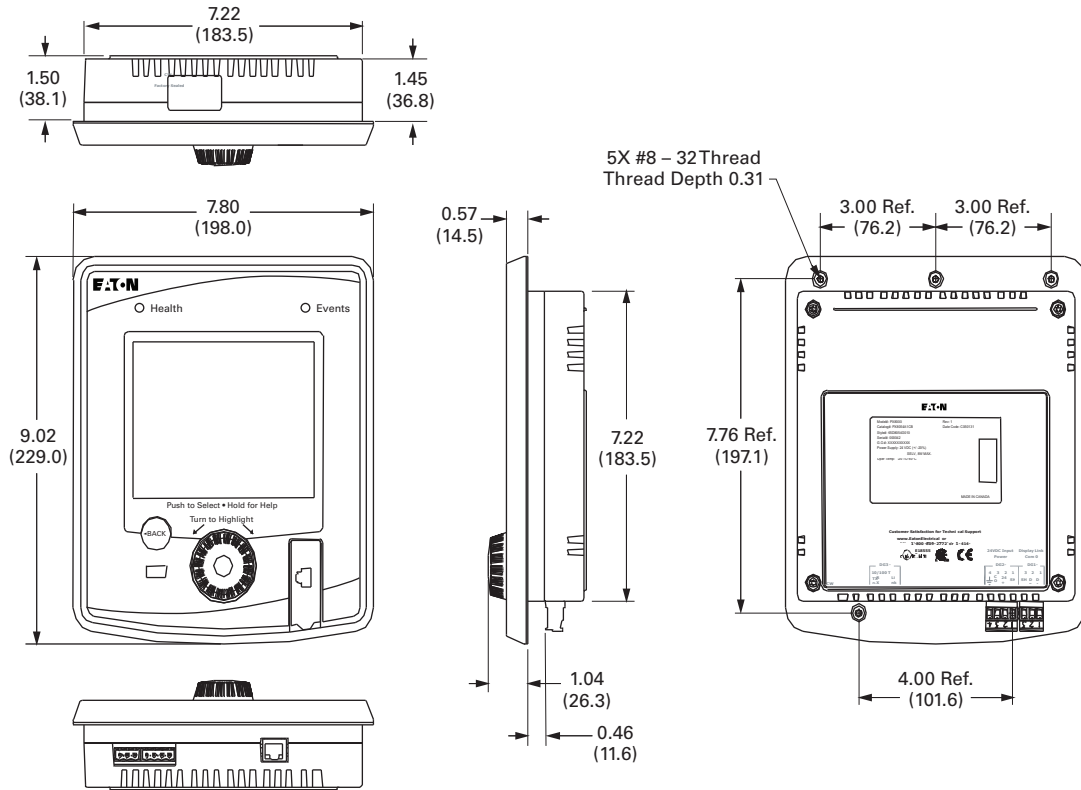

Approximate Dimensions in Inches (mm)

Power Xpert Meter 4000/6000/8000 Module

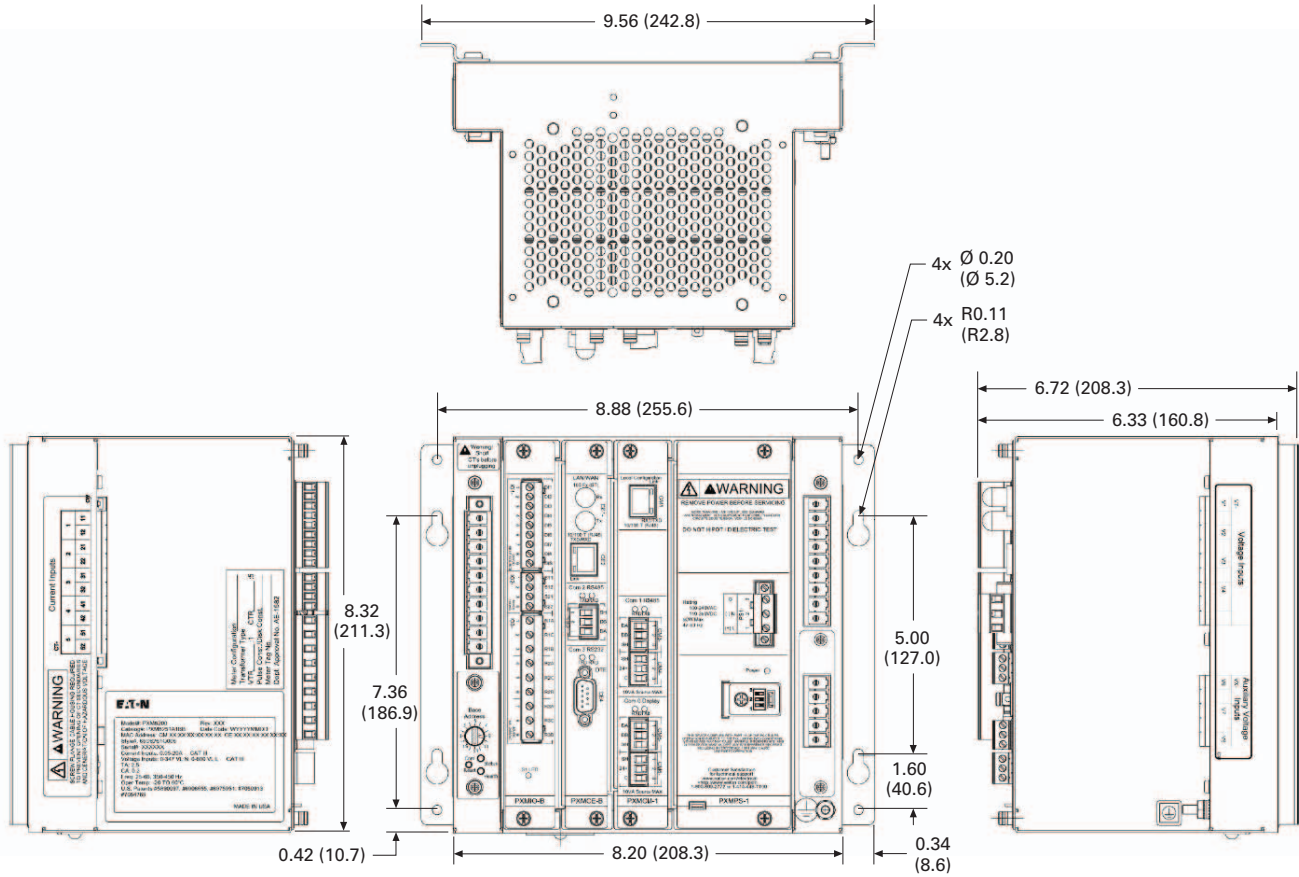

Meter Base Unit

Width	Height	Depth
9.56 (242.8)	8.88 (225.6)	6.72 (170.8) ①

Display Unit

Height	Width	Depth
Projection In Front of Panel Surface		
9.02 (229.0)	7.80 (198.1)	1.04 (26.3)
Behind Panel Surface		
9.02 (229.0)	7.80 (198.1)	1.45 (36.8)

Note

① Including optional wall mounting brackets.

Power Xpert Meter 2000 Series



Contents

<i>Description</i>	<i>Page</i>
Metering Products Family	V3-T9-21
Power Xpert Meter 4000/6000/8000 Series	V3-T9-30
Power Xpert Meter 2000 Series	
IQ 250/260 Series Electronic Power Meters	V3-T9-60
IQ 130/140/150 Series Electronic Power Meters	V3-T9-66
IQ 150S/250S Self-Enclosed Electronic Meters	V3-T9-71
IQ 35M	V3-T9-76
IQ Analyzer 6400/6600 Series	V3-T9-79
IQ DP-4000 Series	V3-T9-87
IQ 230 Meters	V3-T9-93
Power Xpert Multi-Point Meter	V3-T9-100
IQ Energy Sentinel™	V3-T9-112
PM3 Monitoring and Metering Module	V3-T9-121
Current Transformers (CTs)	V3-T9-122
Clamp-On Current Transformers	V3-T9-131
IQ Flange	V3-T9-134
Panel Mounting Adapter Kit	V3-T9-135
Enclosed Meters	V3-T9-136



Power Xpert Meter 2000 Series

Product Description

The Power Xpert Meter 2000 Series power quality instrument monitors the most critical aspects of an electrical distribution system. This premier power quality metering instrument uses the latest in advanced technology to make it simple to use, powerful, scalable and highly flexible. The Power Xpert Meter 2000 offers the same level of intuitive user interface design as the Power Xpert Meter 4000/6000/8000, presenting critical electrical distribution system information in a simple to navigate and easy-to-understand information architecture.

The embedded Web server displays comprehensive power quality data using standard Internet browsers and allows for device configuration from the browser. The embedded Web server presents real time, historical and event information in a browser-style graphical format to help the user interpret information such as current loading, voltage and power levels, power factor, energy usage, I/O status, power quality measurements, as well as harmonic plots. The embedded Web server also allows for waveform capture and for visualizing steady-state harmonic content that is critical for power quality analysis.

The Web server provides the energy and demand readings required to help manage the cost of energy.

Application Description

Identify Power Quality Problems to Help:

- Protect motors from damage
- Preserve the integrity of processes and batches
- Prevent blown capacitor bank fuses
- Protect transformers and conductors from overheating

Monitor Circuit Loading to Help:

- Avoid overloads and nuisance overload trips
- Maximize equipment utilization
- Manage emergency overloads

Manage Energy Utilization to Help:

- Reduce peak demand charges and power factor penalties
- Identify excessive energy consumption

Features, Benefits and Functions

Metered/Monitored Parameters

Note: See Table on Page V3-T9-53.

- Volts: L-L, L-N, Avg. L-L, Avg. L-N
- Phase and neutral currents
- Power: real, reactive and apparent
- Frequency
- Power factor: apparent
- Energy: real, forward, reverse, sum
- Demand: peak with date and time
- % THD
- Minimum and maximum values
- Harmonics
- Individual harmonics
- Demand comparisons
- Phasors

Accuracy

Note: Under typical operating conditions.

- Currents: 0.1% RV
- Voltage: 0.1% RV
- Energy and demand power: 0.2% in accordance with ANSI C12.20
- Frequency: ± 0.03 Hz
- Power factor: 0.2% RV

Communications

Multiple communications ports including:

Standard

- RS-485 Modbus RTU slave port
- 10/100Base-T Ethernet network port

Communication Protocols Supported

- Modbus RTU
- Modbus TCP
- BACnet/IP
- Ethernet TCP/IP
- HTTP, HTTPS
- NTP (Network Time Protocol)
- SMTP (Simple Mail Transfer Protocol)
- SNMP (Simple Network Management Protocol) v1, v3
- DNP 3.0

Physical Characteristics Format

- Power Xpert Meter 2000 with integral display
- Power Xpert Meter 2000 transducer only (no display) meter module
- NEMA rating: NEMA 12, IP42 front of panel rating

Power Xpert 2000 Embedded Web Server

The Power Xpert Meter 2000 embedded Web server offers Eaton customers a new level of accessibility to the critical information required to manage their electrical distribution system. The Web server includes real-time information in both numeric and graphical visual formats to help monitor parameters such as current loading, voltage and power levels, power factor, THD and more. The Web server also provides energy and demand readings with graphic usage plots to help analyze energy usage patterns. Energy readings include kWh, kVARh, delivered and received and kVAh with time.

The Power Xpert Meter 2000 embedded Web server supports graphical trend charts of key measurements such as current, voltage, power and energy. The trend chart supports a zoom feature that allows the user to view data over predefined ranges from as little as 16 hours to as much as 4 years. The trend chart includes zoom in/out buttons and a horizontal slider bar control to manage scrolling forward and backward through the data. Trend charts of basic readings include minimum, maximum and average readings. Trend charts of interval by interval energy data also display peak demand.

Waveform Display

The Power Xpert Meter 2000 can record waveforms at up to 512 samples per cycle. Waveform captures are automatically stored on the FTP server in the IEEE standard COMTRADE file format. This allows users to view and analyze the

waveforms in any standard free-of-charge or commercial COMTRADE file viewer.

Historical Trend Logging

The Power Xpert Meter 2000 records historical data for graphical viewing from the embedded Web server. Graphical views of historical data support pan and zoom. Over 100 standard metering parameters are logged as part of the standard meter functionality including min./max. and average for each parameter. The averages are calculated over the interval period.

Energy Profile Data

The Power Xpert Meter 2000 records Real and Reactive energy forward, reverse, net and absolute sum, as well as apparent energy (kVAh). These readings are stored on a fixed 5 minute interval. Up to 4 status inputs can be configured as energy accumulators for counting KYZ pulse inputs.

Demand Comparisons

Demand usage patterns can be analyzed with the month-to-month, week-to-week comparison chart built into the meter. Raw data can be exported as a csv file with the "Save Table" option to other applications for further analysis and graphing.

Event Triggers

The Power Xpert Meter 2000 has two levels of configurable event triggers:

- On-board meter limits (PXM 2260/2270/2280/2290)
- On-board gateway card limits

The on-board meter limits can be set for any measured parameter, for up to 16 limits. If either of the 16 limits are exceeded, an alarm condition will be present and illuminate one of the LEDs on the meter faceplate. The on-board meter out of limits can also be used to energize a relay output, if so equipped.

The on-board gateway limits can trigger an alarm off of any measured parameter on any of the PXM 2000 model series. These triggers permit pickup, reset and pickup delay to be configured by the user.

Event Logging

The Power Xpert Meter 2000 embedded Web server allows the user to view a list of triggered events. In addition, a separate system log records system operations such as resets.

E-mail

The Power Xpert Meter 2000 contains the ability to send e-mails based on an event that has been triggered or cleared along with the option to send an event or data log file. The Power Xpert Meter 2000 also has the ability to send a configurable periodic e-mail with meter information.

Inputs and Outputs

Power Xpert Meter 2000 is available with a standard KYZ output and optional digital I/O cards that includes:

- Two relay outputs/two status inputs
- Four KYZ pulses/four status inputs
- Four analog outputs 0–1 mA
- Four analog outputs 4–20 mA

Inputs can also be configured for demand synch and pulse counting. Inputs selected for pulse counting can be scaled. Accumulated pulse recordings are maintained in profile memory. Outputs can be used for alarm annunciation.

Ratings

- Application to any PT ratio, no PTs required to 600 Vac
- CT ratios to any CT ratio
- CT inputs available as 5 or 1A secondary
- Separate source control power input:
 - 90–265 Vac or 100–370 Vdc
 - Low voltage 18–60 Vdc

Displayed Information

- Monitored information is available locally through the display, the Web browser or system power management software
- True rms values through 40th harmonic
- ANSI C12.20 Class.2% revenue metering specification

Power Xpert 2000 Web Browser Views



Power Xpert Meter 2000 Web Browser

Power Xpert Meter 2000's embedded Web server offers Eaton customers a new level of accessibility to the critical information required to manage the electrical distribution system. The embedded Web server includes real time circuit information in both numeric and graphical formats to help monitor parameters such as current loading, voltage and power levels and power factor. The Web server also provides the energy and demand readings required to help manage the cost of energy. Readings include kWh, kVARh, delivered and received and kVAh. The Web server also includes critical information regarding power quality such as harmonic distortion.

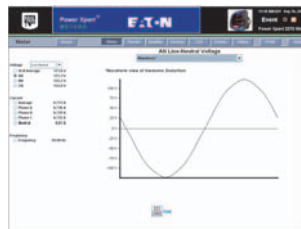

Real-Time Visualization of Harmonic Content

The Web server offers a waveform view to visualize steady-state harmonic content of the voltage and current to spot power quality problems.



Harmonic Spectral Plot

The harmonic spectral plot displays harmonics up to the 40th order. A detailed table also includes individual magnitudes and angles of current and voltage harmonics, at each frequency. Individual and total THD are displayed for diagnostic purposes.



Historical Trend Plot

Graphical Trending of Data

The Power Xpert Meter 2000 embedded Web server supports graphical trend charts of key circuit measurements such as current, voltage, power and energy. The trend chart supports a zoom feature that allows the user to view data over a short period of 16 hours or a longer period of 48 months. The trend chart has a horizontal slider bar control to manage scrolling forward and backward through the data. Trend charts of basic readings include minimum, maximum and average readings. Trend charts of energy data also display demand values.



Energy Demand Profile

Energy managers can view load profile data compared against the peak demand. The plot allows comparison of present and past months' usage.

Web Server Device Configuration

Special software is not required to configure a Power Xpert Meter 2000. The embedded Web server includes a comprehensive device configuration engine.

Discrete Contact Inputs

The optional I/O expansion cards offers two or four digital inputs that are useful for a variety of applications such as:

- Pulse counting of KYZ or other utility pulses such as air, water or gas
- Demand interval timing taken from a master utility meter end of interval pulse

Names can be configured for each input for ease of use.

Relay Outputs

The optional I/O card includes two 5A Form C relay outputs rated for 240 Vac or 30 Vdc or four Form A solid-state outputs. These outputs can be used for applications such as:

- Alarm annunciation
- KYZ pulse output

Alarm outputs can be driven from triggers based on metering values.

Analog Outputs

The optional IO card includes either four 4–20 mA outputs or 0–1 mA outputs. These outputs can be used for applications such as:

- Input to BMS or PLC systems for tracking a measured meter parameter

Standard Communications Card

The standard communications card provides one Ethernet connection and 10/100Base-T port (copper only) that can be used for the following applications:

- Monitoring, managing and configuring the meter remotely using a standard Web browser interface
- Alarm notifications via email, SMTP
- Providing Modbus TCP/IP, RTU and BACnet/IP communications to BMS systems
- Providing SNMP communications to NMS systems
- Synchronizing with an NTP server
- Asset management
- Updating firmware on the meter

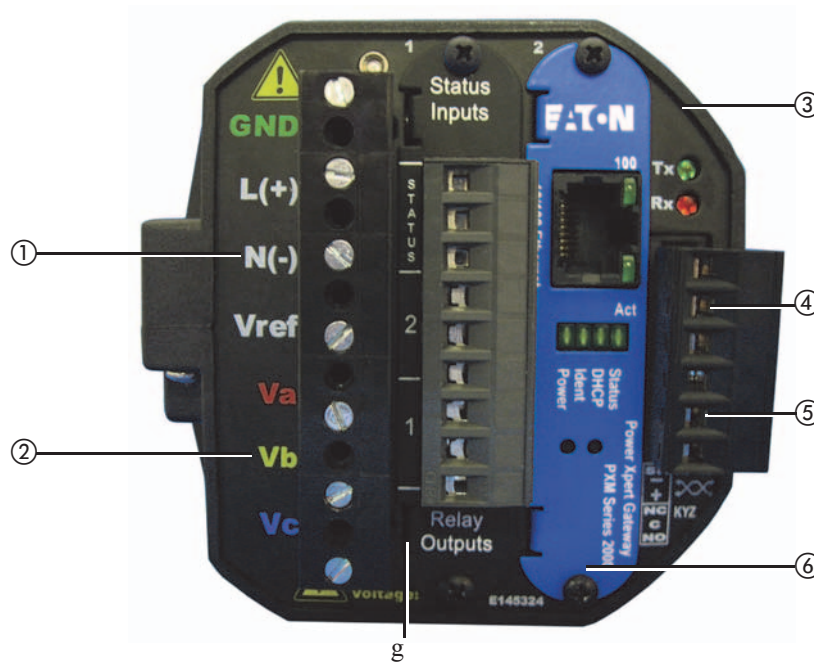
PXM 2000 Rear View

- ① Power supply inputs
- ② System voltage inputs
- ③ NEMA 12 gasket
- ④ RS-485
- ⑤ KYZ out
- ⑥ Meter gateway card
- ⑦ I/O slot

Power Xpert Meter 2250

- Measures basic meter parameters
- 256 MB for data logging
- Ethernet
- On-board gateway card limits/alarms

Power Xpert Meter 2260

Features of PXM 2250 plus:

- Harmonics
- On-board meter hardware limits to activate optional relay outputs
- Visual indication of limits exceeded at meter face
- 512 MB for data logging

Power Xpert Meter 2270

Features of PXM 2260 plus:

- Harmonics, including individual
- Waveform view to visualize steady-state harmonic content
- 768 MB for data logging

The Power Xpert Meter 2280

Features of PXM 2270 plus:

- Records waveforms at up to 64 samples per cycles
- Configures the total, pre- and post-event cycles

Power Xpert Meter 2290

Features of PXM 2280 plus:

- Records waveforms at up to 512 samples per cycles

Power Xpert Meters 2250/2260/2270/2280/2290

Feature	Power Xpert Meter					Benefit
	2250	2260	2270	2280	2290	
General						
Embedded Web server	■	■	■	■	■	Use a standard Web browser to monitor and manage the meter over the network
Firmware flash upgrade support	■	■	■	■	■	Enables you to flash the meter with the latest firmware upgrades
Power, Energy and Demand						
Voltage, current: per phase minimum, maximum, average, trend graph analysis, export, print	■	■	■	■	■	Review voltage and current trends, export, print and analyze parameters right on the meter or external software
Demand: forward, reverse, net sum, profile, export, print, plot comparisons month-to-month, week-to-week	■	■	■	■	■	Plot two months or two weeks for vivid demand comparison, receive e-mails with trend logs
Power, apparent, real, reactive, power factor	■	■	■	■	■	Review power usage and power factor and avoid potential PF penalties
Energy: forward, reverse, net, sum	■	■	■	■	■	Keep track of your energy usage, identify peaks to conserve energy usage, receive e-mails with trend logs
Power Quality Analysis						
Statistical analysis (min., max., average)	■	■	■	■	■	Review statistical trends, identify past and future problem areas
Sampling rate, maximum samples/cycle	400	400	400	400	400	High sampling rate resulting in high accuracy
Security						
Secure two level user access privileges	■	■	■	■	■	Define appropriate security access level per user
Communications						
Modbus TCP	■	■	■	■	■	Easy integration with standard protocol to power management and other software
Modbus RTU	■	■	■	■	■	Integrate meters to existing Modbus networks, daisy chain several (1–32) meters together
BACnet/IP	■	■	■	■	■	Easily integrate into existing building management systems without the need for external protocol adapters
HTTP, HTTPS	■	■	■	■	■	Communicate to the meter over the Internet via standard Web browser
SNMP (Simple Network Management Protocol)	■	■	■	■	■	Communicate with the meter via Simple Network Protocol; hook to existing NMS system
SMTP (Simple Mail Transfer Protocol)	■	■	■	■	■	Send e-mail messages via standard Simple Mail Transfer Protocol
NTP (Network Time Protocol)	■	■	■	■	■	Network Time Protocol support enables the meter to synchronize time over the network
DNP 3.0	■	■	■	■	■	Easy integration with DNP networks (serial)
Trend measurements CSV file export	■	■	■	■	■	Easily export trend measurements to third-party applications, in standard CSV file format

Note

These specifications are subject to change without notice and represent the maximum capabilities of the product with all options installed. This is not a complete feature list. Features and functionality may vary depending on selected options, firmware version and product model. Please refer to the technical data sheet and User Manual for detailed specifications.

Power Xpert Meters 2250/2260/2270, continued

Feature	Power Xpert Meter					Benefit
	2250	2260	2270	2280	2290	
Logs						
Trend logging	■	■	■	■	■	Log trend information for easy statistical analysis
Load profile	■	■	■	■	■	Review the load profile graph to get a better understanding of your electrical load versus time
Event logging	■	■	■	■	■	Log events for retrospective event analysis
Memory and Storage						
Memory, MB	256	512	768	768	768	Store trend data and events for historical analysis
Harmonics						
Harmonic levels		40th	40th	40th	40th	Allows you to identify potential harmful harmonics
Total harmonic distortion (THD)	■	■	■	■	■	Review the total harmonic distortion level directly on the meter
Individual harmonics			■	■	■	Provides simple metric for power quality viewable from the embedded Web server
Waveform						
Waveform display			■	■	■	A single-cycle waveform view on a PC, through embedded Web server, to visualize steady-state harmonic content to identify power quality issues
Waveform recording				64	512	Ability to record waveforms up to specified samples/cycle
I/O						
I/O (two relay outputs/two status inputs, four KYZ pulses/four status inputs, four analog outputs 0–1 mA, four analog outputs 4–20 mA)	Opt	Opt	Opt	Opt	Opt	The Power Xpert meter 2000 I/O Cards are extremely flexible and can be used in a large variety of different applications. Digital inputs and relay outputs can be programmed to interact during various conditions defined by the user. Various third-party devices, such as alarms, pulse meters, trip units and sensors, can be easily integrated to the Power Xpert Meter 2000. Triggers and events can be tied to the meter's standard functions such as e-mail, logs and trends. Analog outputs can be programmed to output meter parameters to BMS or PLC systems

Note
 These specifications are subject to change without notice and represent the maximum capabilities of the product with all options installed. This is not a complete feature list. Features and functionality may vary depending on selected options, firmware version and product model. Please refer to the technical data sheet and User Manual for detailed specifications.

Standards and Certifications

- UL/cUL Electrical and Electronic Measuring and Test Equipment 22CZ
- Accuracy: IEC/EN60687 0.2 Class, ANSI C12.20 0.2 Class
- ANSI C62.41 Burst
- CE Mark



Catalog Number Selection

Power Xpert Meter 2000

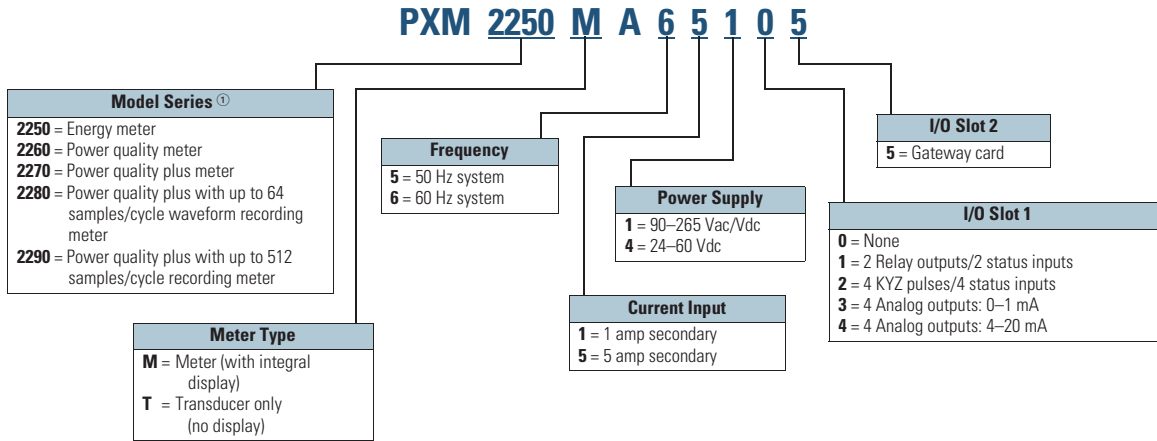

Example 1: **PXM2270MA65145** (PXM 2270 Meter/Display 60 Hz, 5A, 90–265 Vac/Vdc W/4AO)
 Example 2: **PXM2250MA65105** (PXM 2250 Meter/Display 60 Hz, 5A, 90–265 Vac/Vdc)

Note

① Refer to **Page V3-T9-54** for model-specific features.

To order a Power Xpert Meter 2000, the catalog number should be determined using the chart shown above. The chart illustrates how to include the desired factory options as part of a catalog number. Option cards that are selected at time of order entry will be installed at the factory. Option cards are also field installable for future upgrades.

Power Xpert meter modules include panel mounting brackets.

Example 1:
 PXM2270MA65145 (PXM 2270 Meter/Display 60 Hz, 5A, 90–265 Vac/Vdc W/4AO).

Example 2:
 PXM2250MA65105 (PXM 2250 Meter/Display 60 Hz, 5A, 90–265 Vac/Vdc).

Accessories

Power Xpert Meter 2000

Description	Catalog Number
Panel mounting bracket assembly for retrofitting a PXM 2000 to an IQ analyzer/IQ DP4000/IQ data cutout	IQ250-PMAK
PXM 2000 Gateway card kit to upgrade an IQ 250/260 to a PXM 2000	PXM2000-GCK

Power Xpert Meter 2000 I/O Cards

Description	Catalog Number
PXM 2000 I/O card—2 relay outputs/2 status inputs	IQ250/260-I01
PXM 2000 I/O card—4 KYZ Pulses/4 status inputs	IQ250/260-I02
PXM 2000 I/O card—4 analog outputs—0–1 mA	IQ250/260-I03
PXM 2000 I/O card—4 analog outputs—4–20 mA	IQ250/260-I04

Technical Data and Specifications**PXM 2250/2260/2270 Electronic Power Meter Technical Information****Current Inputs**

- Class 10: 5 amp nominal, 10 amp maximum
- Class 2: 1 amp nominal, 2 amp maximum
- Fault current withstand:
 - 100 amps for 10 seconds
 - 300 amps for 3 seconds
 - 500 amps for 1 second
- Continuous current withstand: 20 amps for screw terminated or pass-through connections
- Programmable current: full scale to any CT ratio
- Burden: 0.005 VA per phase maximum at 11 amps
- Pickup current: 0.1% of nominal
 - Class 10: 5 mA
 - Class 2: 1 mA
- Connections:
 - Pass-through wire gauge dimension: 0.177 inches (4.5 mm)
 - Quick connect: 0.25-inch (6.35 mm) male tab

Voltage Inputs

- Range:
 - Line-to-neutral 20–576 Vac
 - Line-to-Line 0–721 Vac
- Programmable voltage range: full scale to any PT ratio
- Supported systems:
 - Three element wye, 2.5 element wye
 - Two element delta, four-wire delta systems
- Input impedance: 1 megohm/phase.
- Burden: 0.36 VA/phase maximum at 600V; 0.014 VA at 120V
- Connection: 7-pin 0.400-inch pluggable terminal block, AWG #12–26 (0.129–3.31 mm²)

Isolation

- All inputs and outputs are galvanically isolated to 2500 volts

Environmental Ratings

- Operating temperature: –20°C to +70°C
- Storage temperature: –20°C to +70°C
- Operating humidity: to 95% RH noncondensing
- Faceplate rating:
 - NEMA 12
 - Mounting gasket included

Sensing Method

- Voltage, current: true rms
- Power: sampling at over 400 samples per cycle on all channels
- Harmonics resolution: 40th order

Update Rate

- Watts, VAR and VA: 100 msec at 60 Hz
- All other parameters: 1 second at 60 Hz

Power Supply

- AC/DC voltage option: 90–265 Vac at 50/60 Hz or 100–370 Vdc, universal AC/DC supply
- DC voltage option: 18–60 Vdc
- Burden: 10 VA maximum

Serial Communications Format

- Connection type: RS-485 (through back plate)
- Com port baud rate: 9600–57,600 bauds
- Com port address: 01–247
- Data format: 8-bit, no parity
- Protocols: Modbus ASCII, RTU or DNP 3.0

Network Communications Format

- Connection type: RJ-45 10/100Base-T Ethernet network port
- Protocols: Ethernet TCP/IP, Modbus TCP, BACnet/IP, HTTP, HTTPS, NTP, SMTP, SNMP

KYZ Pulse

- Contacts: one Form A
- On resistance, maximum: 35 ohms
- Peak switching voltage: 350 Vdc
- Continuous load current: 120 mA
- Peak load current: 350 mA (10 ms)
- Off-state leakage current at 350 Vdc: 1 uA
- Opto-isolation: 3750 Vac

Wiring Diagrams

Service: Wye or Delta, Four-Wire with No PTs, Two or Three CTs

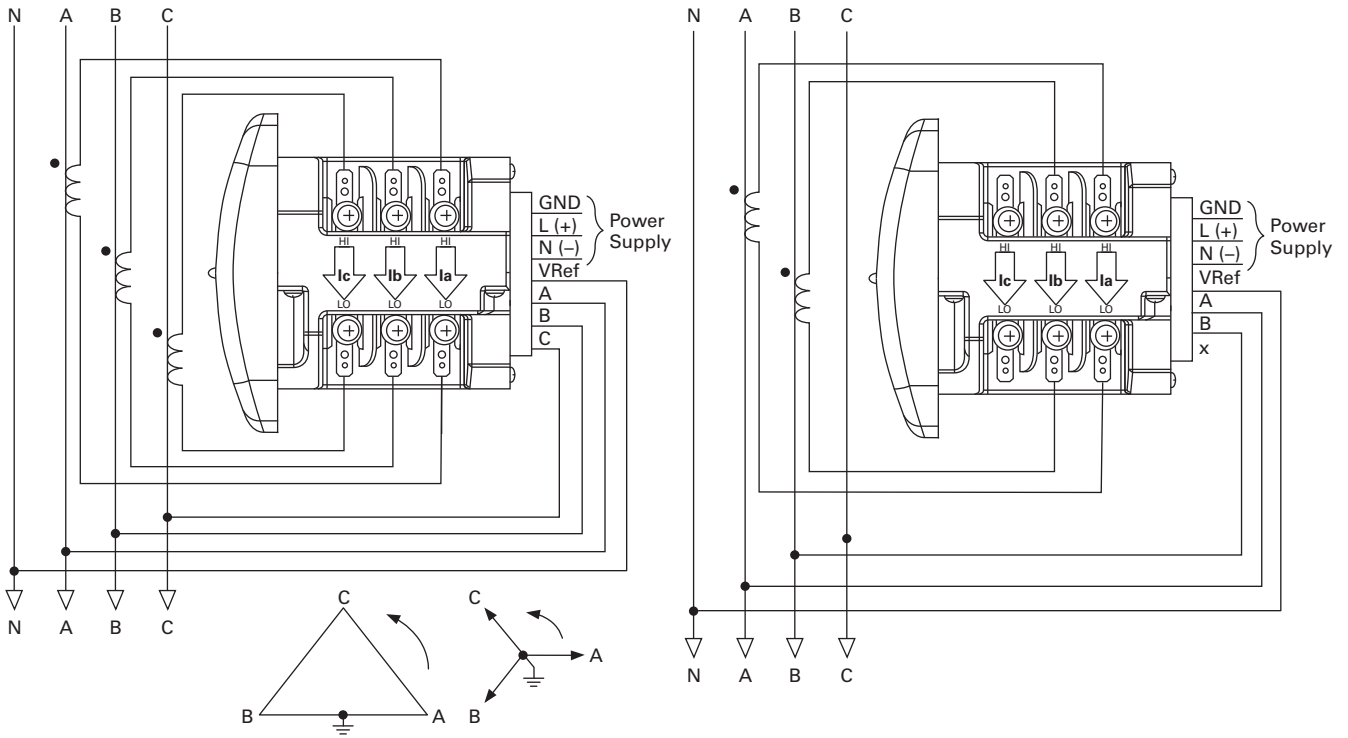

Service: Delta, Three-Wire with No PTs, 2 CTs

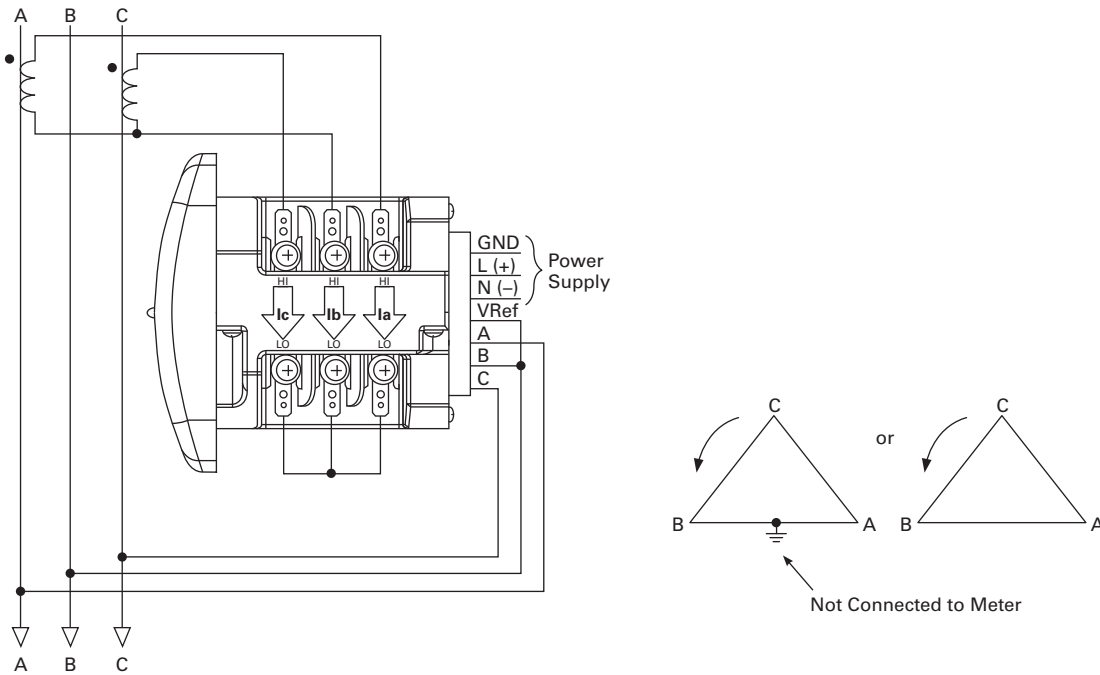

Note: Based upon the voltage rating, you may need a control power transformer for the control power.

Power Xpert Meters Configuration and Wiring Examples

PXM 2000 Display Front View

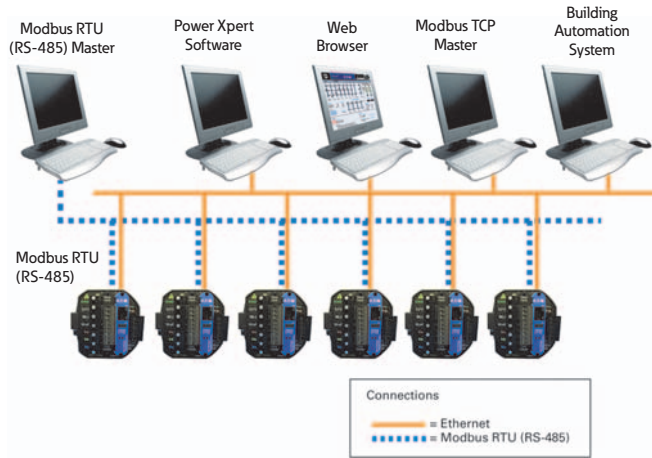

IT Configuration Examples—Accessories—I/O Cards (Option)

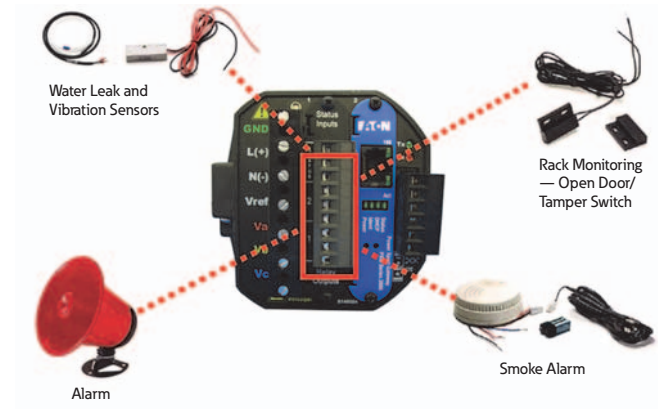

- Two relay programmable outputs/two programmable inputs
- Four KYZ pulses/four programmable inputs
- Four programmable analog outputs

Accessories—I/O Cards (Option)

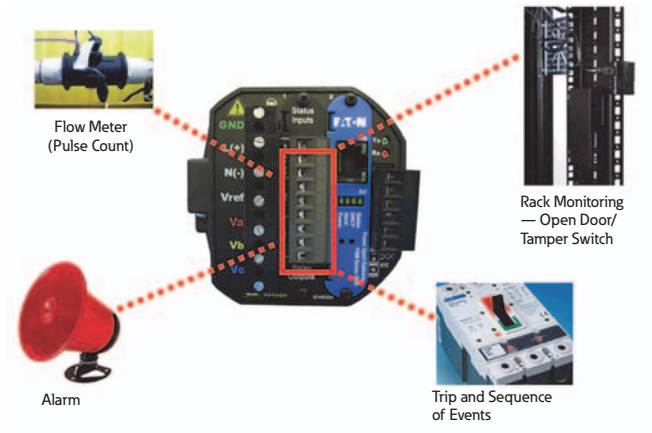

- Two relay programmable outputs/two programmable inputs
- Four KYZ pulses/four programmable inputs
- Four programmable analog outputs

Dimensions

Approximate Dimensions in Inches (mm)

PXM 2000 Display Front View

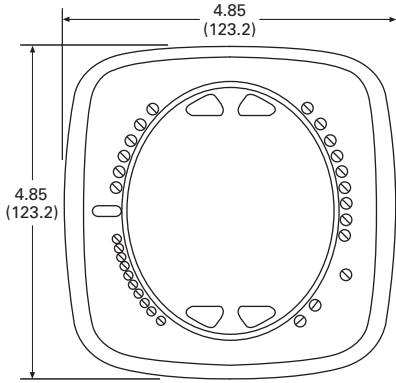

PXM 2000 Transducer Only Side View

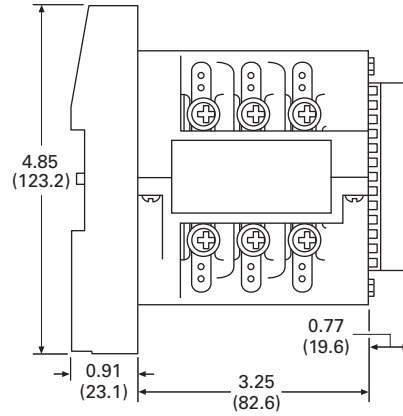

PXM 2000 Rear View

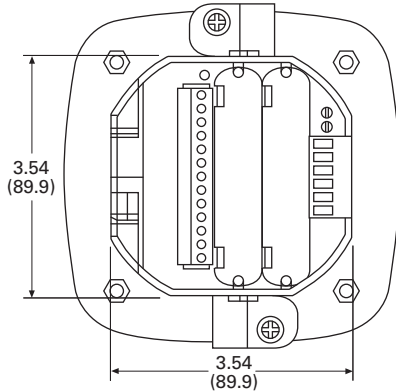

ANSI Mounting Panel Cutout

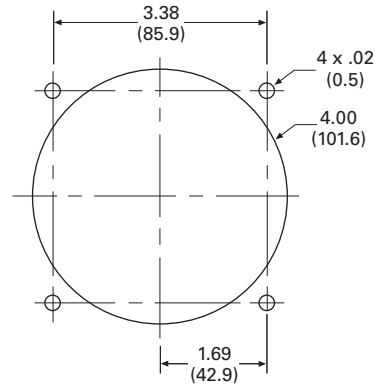

PXM 2000 Meter/Display Side View

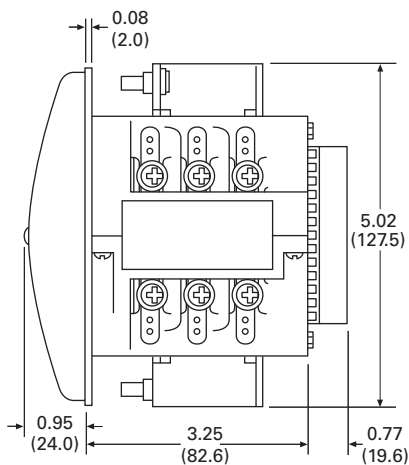

DIN Mounting Cutout

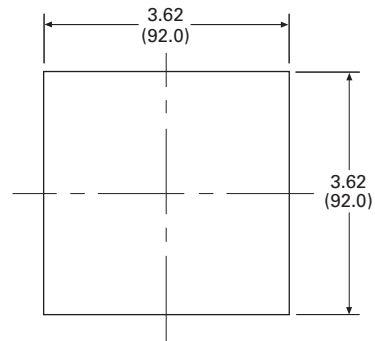

Description	Specifications
Weight	2 lbs (0.9 kg)
Basic unit	5.00 (127.0) H x 4.90 (124.5) W x 5.00 (127.0) L
PXM 2250/2260/2270	Mounts in 3.62-inch (92.0) mm DIN and ANSI C39.1 round cut-outs
Shipping container dimensions	6-inch cube
Tolerance	±0.1 inches (2.54 mm)
Projection in front of panel surface	4.85 (123.2) H x 4.85 (123.2) W x 1.01 (25.6) L
Projection behind panel surface	4.85 (123.2) H x 4.85 (123.2) W x 1.01 (25.6) L

IQ 250 and 260 Electronic Power Meters



Contents

<i>Description</i>	<i>Page</i>
Metering Products Family	V3-T9-21
Power Xpert Meter 4000/6000/8000 Series	V3-T9-30
Power Xpert Meter 2000 Series	V3-T9-49
IQ 250/260 Series Electronic Power Meters	
Standards and Certifications	V3-T9-61
Catalog Number Selection	V3-T9-62
Accessories	V3-T9-62
Technical Data and Specifications	V3-T9-63
Dimensions	V3-T9-65
IQ 130/140/150 Series Electronic Power Meters	V3-T9-66
IQ 150S/250S Self-Enclosed Electronic Meters	V3-T9-71
IQ 35M	V3-T9-76
IQ Analyzer 6400/6600 Series	V3-T9-79
IQ DP-4000 Series	V3-T9-87
IQ 230 Meters	V3-T9-93
Power Xpert Multi-Point Meter	V3-T9-100
IQ Energy Sentinel™	V3-T9-112
PM3 Monitoring and Metering Module	V3-T9-121
Current Transformers (CTs)	V3-T9-122
Clamp-On Current Transformers	V3-T9-131
IQ Flange	V3-T9-134
Panel Mounting Adapter Kit	V3-T9-135
Enclosed Meters	V3-T9-136

IQ 250/260 Series Electronic Power Meters

Product Description

The IQ 250 and IQ 260 Meters provide capabilities you would not normally expect in affordable, ultra-compact meters, such as fast sampling rate and accurate metering for a full range of power attributes. Providing the first line of defense against costly power problems, Eaton's IQ 250 and IQ 260 electronic power meters can perform the work of an entire wall of legacy metering equipment using today's technology.

When space is at a premium, yet you need ANSI C12.20 accuracy, the IQ 250/ 260 series fit the bill. These meters are ideal for electrical equipment assemblies, machine control panels, such as panelboard and switchboard mains and feeders, low voltage metal-enclosed switchgear feeders and motor control centers. Requiring far less space than other meters with similar functionality, IQ 250/260 series fit into a standard ANSI or IEC cutout on a panelboard or other electrical equipment, and therefore fit easily into retrofit applications.

Application Description

- Utility and commercial metering
- Substations, industrial facilities, power generation sites and campuses
- Sub-metering
- Load studies and voltage recording
- Analog meter replacement

Features and Benefits

- Measure and display real-time information about critical power parameters with a sampling rate of 400 samples per cycle
- Monitor power utilization and quality with ANSI C12.20 accuracy (0.2 percent)
- Optional 128 KB for data logging, which guards against loss of historical data
- Verify meter accuracy with KYZ test pulse self-certification capabilities
- Standard Modbus RTU communications
- Available as transducer only or with display
- Designed to accommodate upgrades
- Integrate into Eaton's Power Xpert architecture for a holistic system-level view

Additional Features

Features of IQ 250 and IQ 260 Electronic Power Meters

Features	IQ 250	IQ 260
Instrumentation		
Current, per phase	■	■
Current demand	■	■
Calculated neutral current	■	■
Voltage, per phase (L-L, L-N)	■	■
Frequency	■	■
Power, Energy and Demand		
Real, reactive and apparent power, total and per phase (kW, kVAR, kVA)	■	■
Real, reactive and apparent energy, total and per phase (kWh, kVARh, kVAh)	■	■
Real, reactive and apparent power demand	■	■
Power factor, total and per phase	■	■
Min./max. readings, I, V, PF, F, THD (IQ 260), kW, kVAR, kVA	■	■
Demand Methods		
Block interval (sliding, fixed)	■	■
Communications		
RS-485	■	■
KYZ output	■	■
Modbus RTU	■	■
Modbus ASCII	■	■
DNP 3.0	■	■
Data Logging		
128 KB for data logging	Opt.	Opt.
I/O		
Two digital in /two digital out ^①	Opt.	Opt.
Four digital in/four KYZ out	Opt.	Opt.
Four analog output (4–20 mA) ^②	Opt.	Opt.
Four analog output (0–1 mA)	Opt.	Opt.
Power Quality Analysis		
Total harmonic distortion (THD) voltage and current per phase		■
Alarming		
Set point driven alarm		■

Notes

① Digital out with IQ 250 requires external command.

② Requires external power supply.

Standards and Certifications

- IEC 687: 0.2% accuracy
- ANSI C12.20: 0.2% accuracy
- ANSI C62.41: Burst
- UL/cUL: Electrical and electronic measuring and test equipment 22CZ



Catalog Number Selection

IQ 250/260 Meter

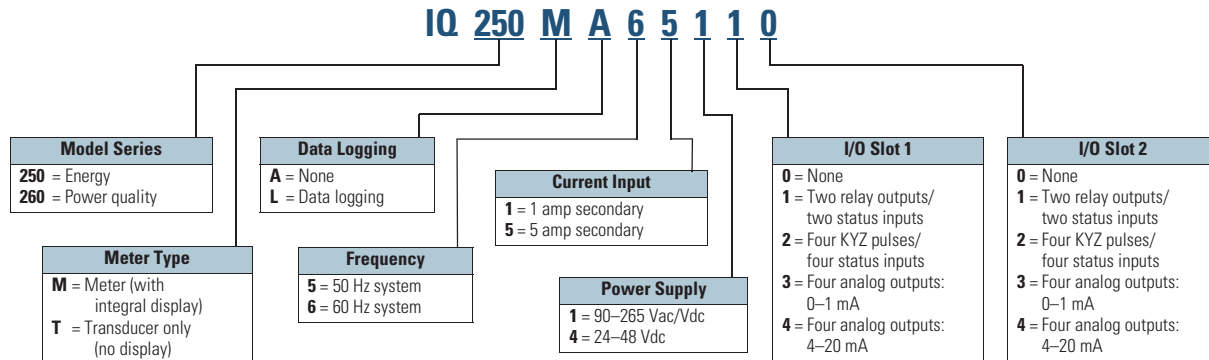

9

Accessories

IQ 250/260 Meter

Description	Catalog Number
Panel mounting adapter for retrofitting an IQ 250/260 to an IQ Analyzer/IQ DP-4000/IQ data cutout	IQ250-PMAK
PXM 2000 Gateway card kit to upgrade an IQ 250/260 to a PXM 2000	PXM2000-GCK

IQ 250/260 Meter I/O Cards

Description	Catalog Number
IQ 250/260 I/O card—2 relay outputs/2 status inputs	IQ250/260-I01
IQ 250/260 I/O card—4 KYZ pulses/4 status inputs	IQ250/260-I02
IQ 250/260 I/O card—4 analog outputs—0–1 mA	IQ250/260-I03
IQ 250/260 I/O card—4 analog outputs—4–20 mA	IQ250/260-I04

Technical Data and Specifications

IQ 250/260 Electronic Power Meter

Description	Specifications
Current Inputs	
Class 10	5 amp nominal, 10 amp max.
Class 2	1 amp nominal, 2 amp max.
Fault current withstand	
100 amps for:	10 seconds
300 amps for:	3 seconds
500 amps for:	1 second
Continuous current withstand	20 amps for screw terminated or pass-through connections
Programmable current	Full scale to any CT ratio
Burden	0.005 VA per phase max. at 11 amps
Pickup current	0.1% of nominal
Class 10	5 mA
Class 2	1 mA
Connections	
Pass-through wire gauge dimension	0.177 inches (4.5 mm)
Quick connect	0.25-inch male tab
Voltage Inputs	
Range	
Line-to-neutral	20–576 Vac
Line-to-line	0–721 Vac
Programmable voltage range	Full scale to any PT ratio
Supported systems	3 element wye, 2.5 element wye, 2 element delta, four-wire delta systems
Input impedance	1 meg ohm/phase
Burden	0.36 VA/phase max. at 600V; 0.014 VA at 120V
Connection	7-pin 0.400-inch pluggable terminal block, AWG #12–26 (0.129–3.31 mm ²)
Isolation	
All inputs and outputs are galvanically isolated to 2500 volts.	
Environmental Ratings	
Operating temperature	–20°C to +70°C
Storage temperature	–20°C to +70°C
Operating humidity	To 95% RH noncondensing
Faceplate rating	NEMA 12 Water-resistant Mounting gasket included

Description	Specifications
Sensing Method	
Voltage, current	True rms
Power	Sampling at over 400 samples per cycle on all channels
Harmonics resolution	40th order
Update Rate	
Watts, VAR and VA	100 msec at 60 Hz
All other parameters	1 second at 60 Hz
Power Supply	
AC/DC voltage option	90–265 Vac at 50/60 Hz or 100–370 Vdc, universal AC/DC supply
DC voltage option	18–60 Vdc
Burden	10 VA max.
Standard Communications Format	
Connection type	RS-485 (through back plate)
Com port baud rate	9600–57,600 bauds
Com port address	01–247
Data format	8-bit, no parity
Protocols	Modbus ASCII, RTU or DNP 3.0
KYZ Pulse	
Contacts	1 Form A
On resistance, max.	35 ohms
Peak switching voltage	350 Vdc
Continuous load current	120 mA
Peak load current	350 mA (10 ms)
Off-state leakage current at 350 Vdc	1 μ A
Opto-isolation	3750 Vac

9.3

Metering Devices, Protective Relays, Software and Connectivity

Metering Devices

Wiring Diagrams

Service: Wye or Delta, Four-Wire with No PTs, Two or Three CTs

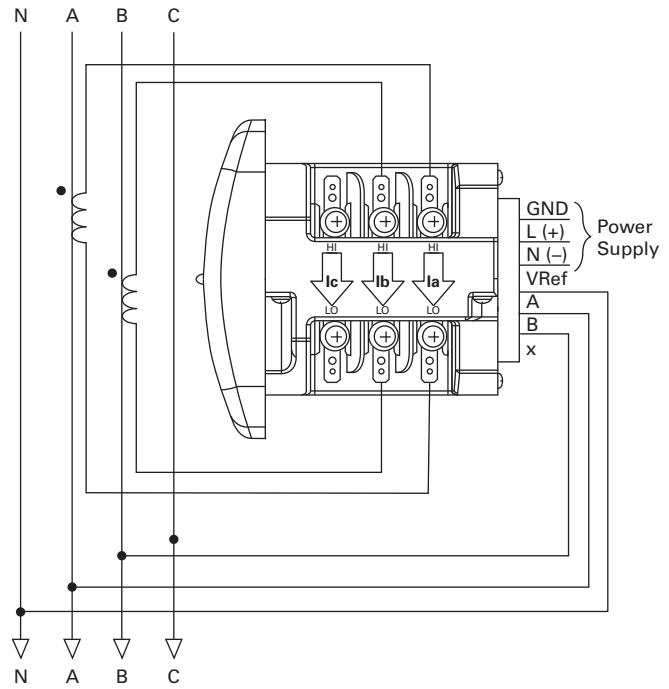
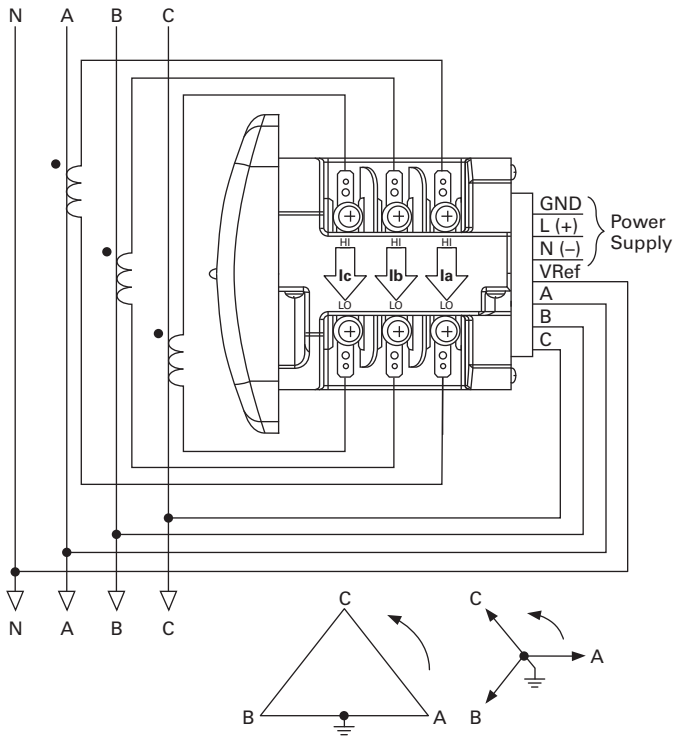

9

Service: Delta, Three-Wire with No PTs, 2 CTs

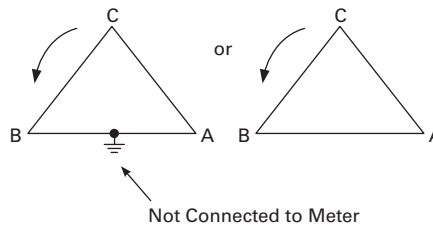
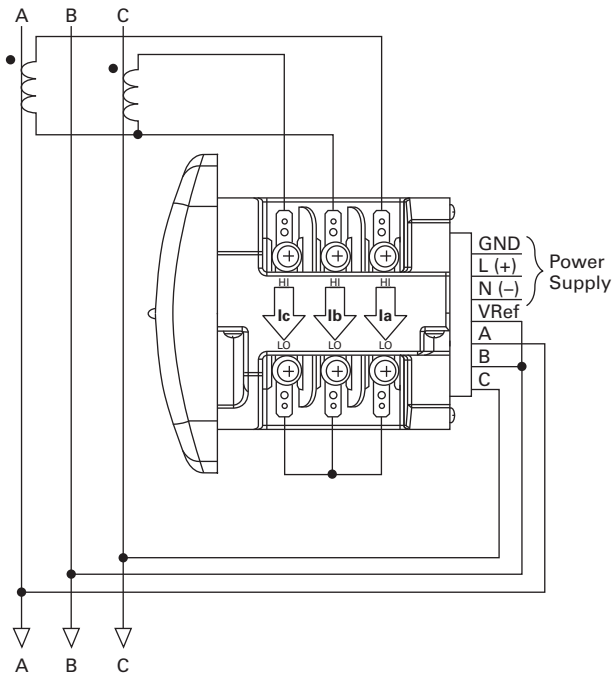

Note: Based upon the voltage rating, you may need a control power transformer for the control power.

Dimensions

Approximate Dimensions in Inches (mm)

IQ 250/260 Meter—Face and Side Views

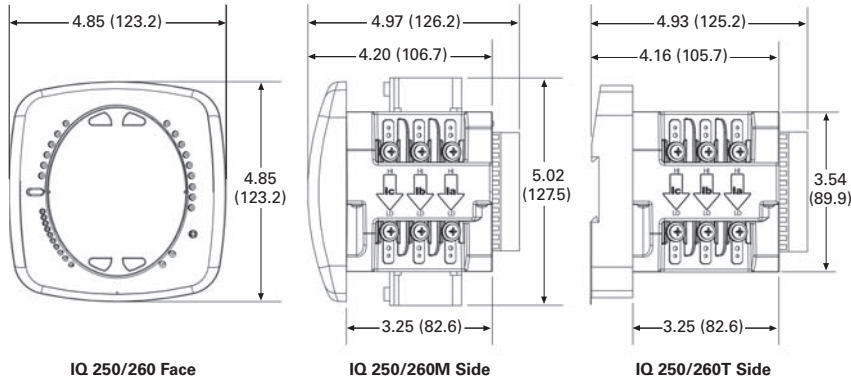

Expandable IQ Componentry

ANSI Mounting Panel Cutout

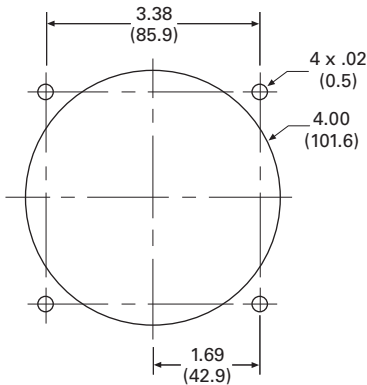

DIN Mounting Cutout

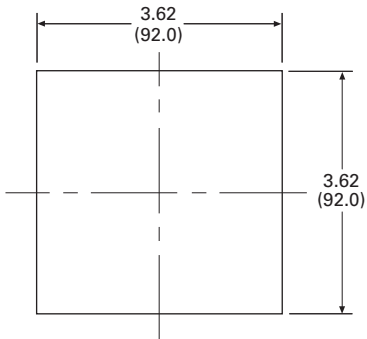

Description	Specifications
Weight	2 lbs (0.9 kg)
Basic unit	5.00 (127.0) H x 4.90 (124.5) W x 5.00 (127.0) L
IQ 250/260	Mounts in 92 mm DIN and ANSI C39.1 round cut-outs
Shipping container dimensions	6-inch cube
Tolerance	±0.1 inches (2.54 mm)
PXM 2250/2260/2270	Mounts in 3.62-inch (92.0) mm DIN and ANSI C39.1 round cut-outs
Projection in front of panel surface	4.85 (123.2) H x 4.85 (123.2) W x 1.01 (25.6) L
Projection behind panel surface	4.85 (123.2) H x 4.85 (123.2) W x 1.01 (25.6) L

IQ 100



9

Contents

Description

	<i>Page</i>
Metering Products Family	V3-T9-21
Power Xpert Meter 4000/6000/8000 Series	V3-T9-30
Power Xpert Meter 2000 Series	V3-T9-49
IQ 250/260 Series Electronic Power Meters	V3-T9-60
IQ 130/140/150 Series Electronic Power Meters	
Standards and Certifications	V3-T9-67
Catalog Number Selection	V3-T9-67
Accessories	V3-T9-67
Technical Data and Specifications	V3-T9-68
Dimensions	V3-T9-70
IQ 150S/250S Self-Enclosed Electronic Meters	V3-T9-71
IQ 35M	V3-T9-76
IQ Analyzer 6400/6600 Series	V3-T9-79
IQ DP-4000 Series	V3-T9-87
IQ 230 Meters	V3-T9-93
Power Xpert Multi-Point Meter	V3-T9-100
IQ Energy Sentinel™	V3-T9-112
PM3 Monitoring and Metering Module	V3-T9-121
Current Transformers (CTs)	V3-T9-122
Clamp-On Current Transformers	V3-T9-131
IQ Flange	V3-T9-134
Panel Mounting Adapter Kit	V3-T9-135
Enclosed Meters	V3-T9-136

IQ 130/140/150 Series Electronic Power Meters

Product Description

The IQ 100 Meter family provides capabilities you would not normally expect in affordable, compact meters, such as fast sampling rate and accurate metering for a full range of power attributes. Providing the first line of defense against costly power problems, Eaton's IQ 100 series electronic power meters can perform the work of an entire wall of legacy metering equipment utilizing today's technology.

When space is at a premium, yet you need ANSI C12.20 accuracy, the IQ 100 series fit the bill. These meters are ideal for electrical equipment assemblies, machine control panels, such as panelboard and switchboard mains and feeders, low voltage metal-enclosed switchgear feeders and motor control centers. Requiring far less space than other meters with similar functionality, IQ 100 series fit into a standard ANSI or IEC cutout on a panelboard or other electrical equipment, and therefore fit easily into retrofit applications.

Application Description

- Utility and commercial metering
- Substations, industrial facilities, power generation sites and campuses
- Sub-metering
- Load studies and voltage recording
- Analog meter replacement

Features and Benefits

- Measure and display real-time information about critical power parameters with a sampling rate of 400 samples per cycle
- Monitor power utilization and quality with ANSI C12.20 accuracy (0.5%)
- Verify meter accuracy with KYZ test pulse self-certification capabilities
- Optional Modbus RTU or TCP communications
- Available as transducer only or with display
- Designed to accommodate upgrades
- Integrate into Eaton's Power Xpert Architecture for a holistic system-level view

IQ 100 Electronic Power Meters

Features	IQ 130	IQ 140	IQ 150
Instrumentation			
Current, per phase	■	■	■
Current demand	■	■	■
Calculated neutral current	■	■	■
Voltage, per phase (L-L, L-N)	■	■	■
Min./max. readings, I, V	■	■	■
Min./max. readings, I, V, PF, F, W, VAR, VA		■	■
Frequency		■	■
Power			
Real, reactive and apparent power, total (W, VAR, VA)		■	■
Power factor, total		■	■
Real, reactive and apparent power demand		■	■
Demand Methods			
Block interval (sliding, fixed)		■	■
Energy			
Real, reactive and apparent energy, total (Wh, VAR, VAh)			■
Communications			
RS-485, Modbus RTU, Modbus ASCII, KYZ output	Opt.	Opt.	Opt.
RJ45, Modbus TCP, KYZ output	Opt.	Opt.	Opt.

Standards and Certifications

- IEC 687: 0.5% accuracy
- ANSI C12.20: 0.5% accuracy
- ANSI C62.41: Burst
- CE
- UL/cUL: Electrical and Electronic Measuring and Test Equipment 22CZ



Catalog Number Selection

IQ 100 Meter

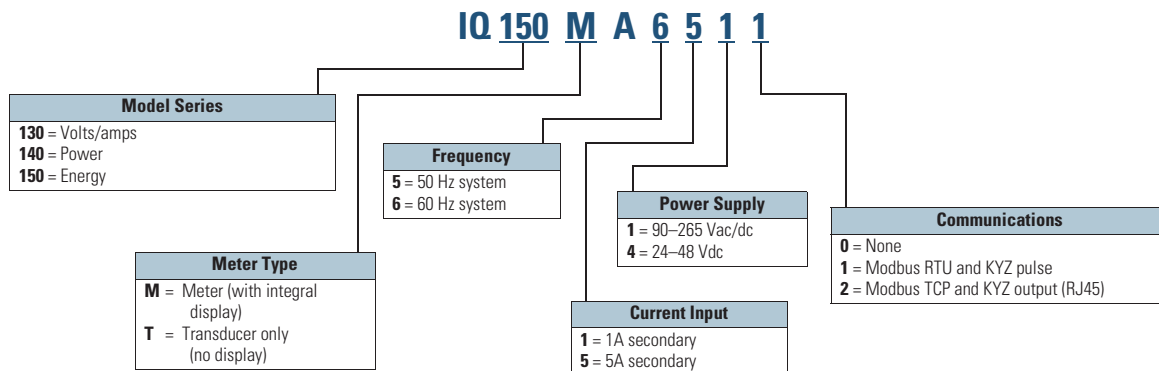

Accessories

IQ 100 Meter

Description	Catalog Number
Panel Mounting Adapter for retrofitting an IQ 100 to an IQ Analyzer/IQ DP-4000/IQ Data Cutout	IQ250-PMAK

Technical Data and Specifications

IQ 100 Electronic Power Meters

Description	Specifications
Current Inputs	
Class 10	5A nominal, 10A max.
Class 2	1A nominal, 2A max.
Fault current withstand	
100A for:	10 seconds
300A for:	3 seconds
500A for:	1 second
Continuous current withstand	20A for screw terminated or pass-through connections
Programmable current	Full scale to any CT ratio
Burden	0.005 VA per phase max. at 11A
Pickup current	0.1% of nominal
Class 10	5 mA
Class 2	1 mA
Connections	
Pass-through wire gauge dimension	0.177-inch (4.5 mm)
Quick connect	0.25-inch male tab
Voltage Inputs	
Range	
Line-to-neutral	20–416 Vac
Line-to-line	20–721 Vac
Programmable voltage range	Full scale to any PT ratio
Supported systems	3 element wye, 2.5 element wye, 2 element delta, four-wire delta systems
Input impedance	1 megohm/phase
Burden	0.36 VA/phase max. at 600V; 0.014 VA at 120 volts
Connection	7-pin 0.400-inch pluggable terminal block, AWG #12–26 (0.129–3.31 mm ²)
Isolation	
All inputs and outputs are galvanically isolated to 2500 volts.	
Environmental Ratings	
Operating temperature	–20°C to +70°C
Storage temperature	–40°C to +85°C
Operating humidity	To 95% RH noncondensing
Faceplate rating	NEMA 12 water-resistant mounting gasket included

IQ 100 Electronic Power Meters, continued

Description	Specifications
Sensing Method	
Voltage, current	True RMS
Power	Sampling at over 400 samples per cycle on all channels
Update Rate	
Watts, VAR and VA	100 msec at 60 Hz
All other parameters	1 second at 60 Hz
Power Supply	
AC/DC voltage option	90–265 Vac at 50/60 Hz or 100–370 Vdc, Universal AC/DC supply
DC voltage option	18–60 Vdc
Burden	10 VA max.
Optional Communications Format	
Connection type	RS-485 or RJ45 (through back plate)
Com port baud rate	9600–57,600 bauds
Com port address	01–247
Data format	8-bit, no parity
Protocols	Modbus ASCII, RTU, TCP
Optional KYZ Pulse	
Contacts	1 Form A
On resistance, max.	35 ohms
Peak switching voltage	350 Vdc
Continuous load current	350 mA (10 ms)
Off-state leakage current at 350 Vdc	1 uA
Opto-isolation	3750 Vac

Note

These specifications are subject to change without notice and represent the maximum capabilities of the product with all options installed. This is not a complete feature list. Features and functionality may vary depending on selected options, firmware version and product model. Please refer to the technical data sheet and User Manual for detailed specifications.

Wiring Diagrams

Service: Wye or Delta, Four-Wire with No PTs, Two or Three CTs

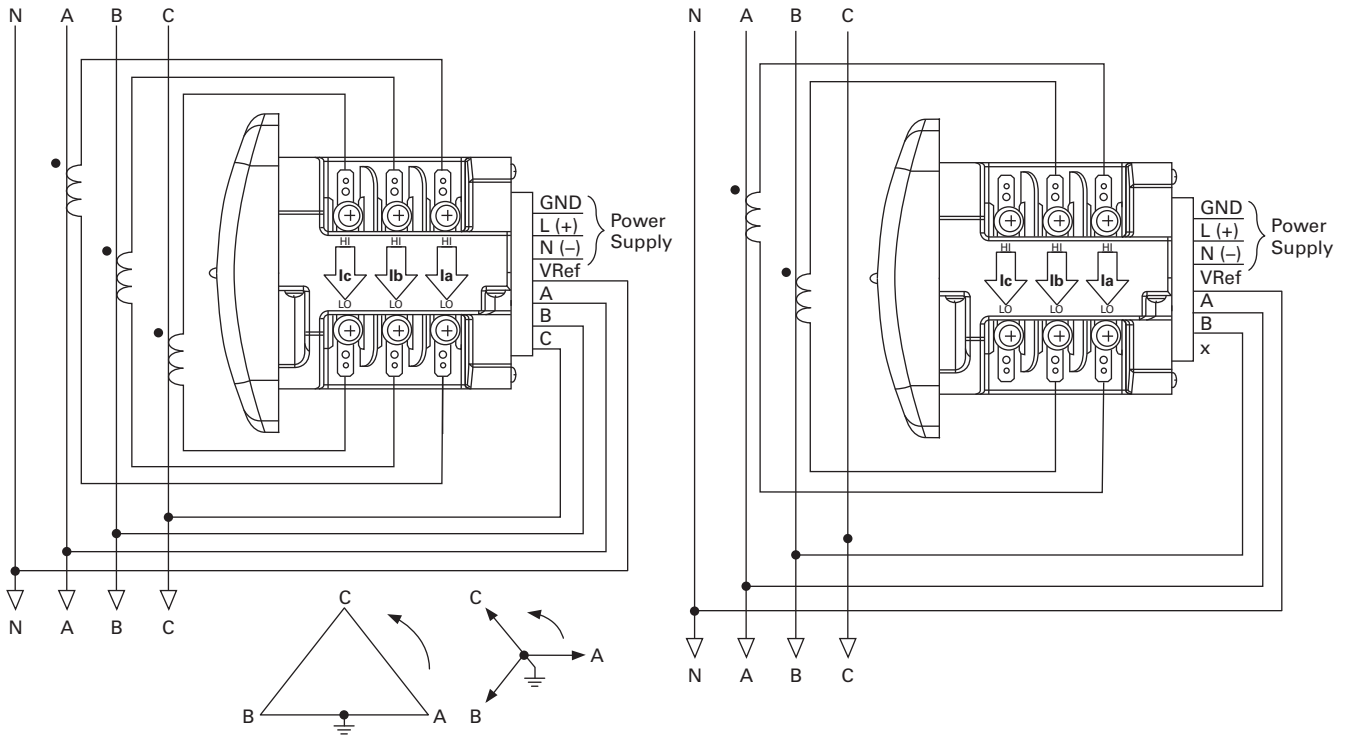

Service: Delta, Three-Wire with No PTs, 2 CTs

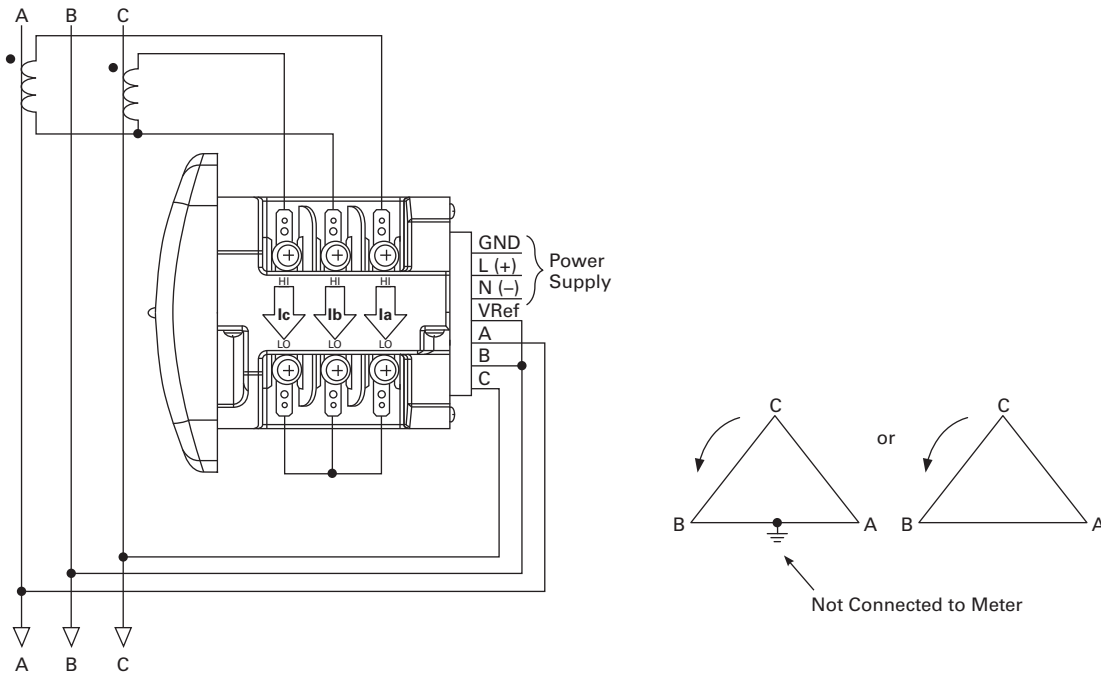

Note: Based upon the voltage rating, you may need a control power transformer for the control power.

Dimensions

Approximate Dimensions in Inches (mm)

IQ 100 Meter—Face and Side Views

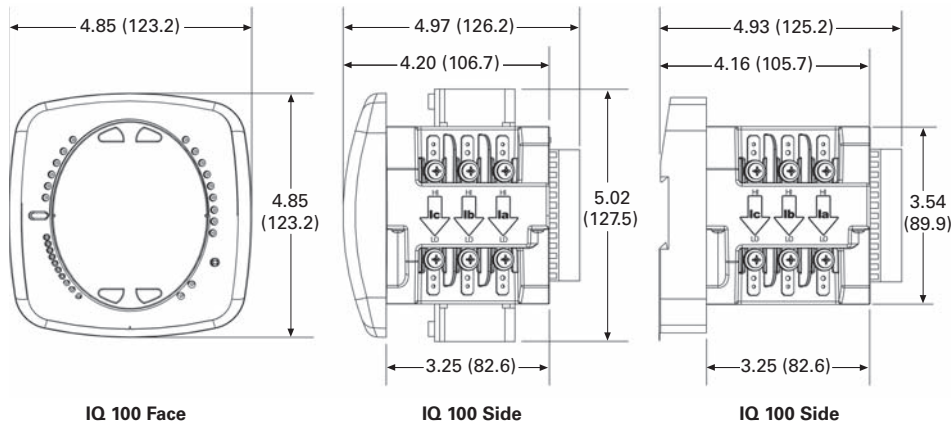

ANSI Mounting Panel Cutout

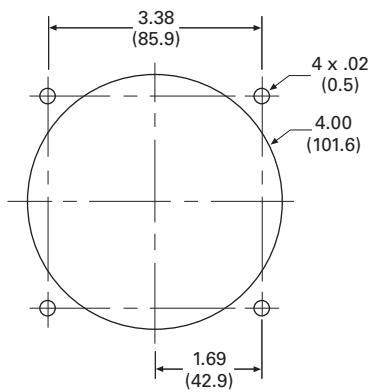

DIN Mounting Cutout

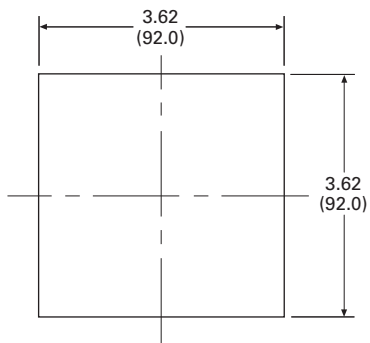

Description	Specifications
Weight	2 lbs (0.9 kg)
Basic unit	5.00 (127.0) H x 4.90 (124.5) W x 5.00 (127.0) L
IQ 100	Mounts in 92 mm DIN and ANSI C39.1 round cut-outs
Shipping container dimensions	6-inch cube
Tolerance	±0.1 inches (2.54 mm)

IQ 150S/250S Self-Enclosed Electronic Meters



Contents

Description

Metering Products Family	V3-T9-21
Power Xpert Meter 4000/6000/8000 Series	V3-T9-30
Power Xpert Meter 2000 Series	V3-T9-49
IQ 250/260 Series Electronic Power Meters	V3-T9-60
IQ 130/140/150 Series Electronic Power Meters	V3-T9-66
IQ 150S/250S Self-Enclosed Electronic Meters	
Catalog Number Selection	V3-T9-73
Technical Data and Specifications	V3-T9-74
Wiring Diagrams	V3-T9-75
Dimensions	V3-T9-75
IQ 35M	V3-T9-76
IQ Analyzer 6400/6600 Series	V3-T9-79
IQ DP-4000 Series	V3-T9-87
IQ 230 Meters	V3-T9-93
Power Xpert Multi-Point Meter	V3-T9-100
IQ Energy Sentinel™	V3-T9-112
PM3 Monitoring and Metering Module	V3-T9-121
Current Transformers (CTs)	V3-T9-122
Clamp-On Current Transformers	V3-T9-131
IQ Flange	V3-T9-134
Panel Mounting Adapter Kit	V3-T9-135
Enclosed Meters	V3-T9-136

IQ 150S/250S Self-Enclosed Electronic Meters

Product Description

With energy costs skyrocketing, you need the ability to verify the accuracy of utility billing and allocation of energy costs among business units, different manufacturing areas or facilities, and tenants. Production equipment and IT systems are vulnerable to power anomalies; therefore, you must ensure that power is always up to specifications. If your infrastructure is an established facility, you may not currently have metering or may have addressed these concerns by deploying a variety of analog gauges and meters—one for volts, one for amperes and so on, with separate meters for each measurement.

If you're planning an upgrade or a new power infrastructure, no doubt you would like to capitalize on the latest technology to improve upon that cumbersome architecture and its patchwork view.

Application Description

- Industrial and commercial buildings, metering and submetering
- Government facilities and military
- Universities and airports
- Load studies and voltage recording

Features and Benefits

- Self-enclosed, these meters are an ideal solution for surface mounting next to a selected piece of equipment for energy monitoring
- NEMA 12 enclosure with a large, easy-to-read faceplate, consistent with other Eaton meter models, designed with "knockouts" for easy installation
- Ethernet communications option for either wired or wireless setup, allowing for additional ease of installation and integration into existing networks
- Available data and alarm recording for historical records/trending

- Integrate into Eaton's Power Xpert® Architecture for a holistic system-level view

Wireless and High-End Capabilities you would not Expect from a Self-Enclosed, Compact Meter

Providing the first line of defense against costly power problems, Eaton's IQ 150S/250S electronic self-enclosed meters can perform the work of an entire wall of legacy metering equipment using today's secure wireless technology. Eaton's IQ 150S/250S meters use 24-bit AD converters that sample at more than 400 samples per cycle and meet IEC 687 (0.2% accuracy) and ANSI C12.20 (0.2% accuracy) standards. With such high-performance measurement capability, these meters can be confidently used for primary revenue metering and submetering applications.

Either model will help you monitor energy demand, while the IQ 250S provides the extra benefit of also

monitoring and recording the changes in the characteristics of your power.

Eaton's IQ 150S/250S meters provide direct-reading metered values for the most critical power aspects, such as watts, watt demand, watthours, voltage amperes (VA), VA-hours, VARs, VAR-hours and power factor. They have high sampling speed and accuracy.

These meters are self-enclosed in a NEMA 12 enclosure with "knockouts" on the bottom for communication and power, providing for an easy installation.

Perhaps you don't have network drops in all the right places. The IQ 150S/250S offers a wireless communications option. The transmissions are encrypted using 128-bit Wired Equivalent Privacy (WEP) for security.

Industry-Standard Communication Protocols Standard Modbus RS-485 Communication

Standard communication includes an RS-485 output speaking Modbus protocol. This allows the unit to be connected to any serial RS-485 bus using the Modbus interface. The unit communicates easily with most building automation, Power Xpert Software or other software systems. Baud rates are up to 57.6K baud to provide fast update times.

Wi-Fi or Land-Based Ethernet

The unit offers an Ethernet option—configured either as an RJ45 or Wi-Fi connection. The Wi-Fi configuration allows the 150S/250S to be used on standard Wi-Fi base stations. The unit is assigned an IP address; it communicates Modbus protocol over Ethernet TCP/IP. Wireless Ethernet is reliable and easy to integrate, making it the superior solution for mass meter deployment.

KYZ Pulse

For applications in which a pulse is needed, the unit also provides a KYZ output that pulses proportional to the amount of energy consumed. This feature is used for pulse counting applications into building management systems where serial or Ethernet protocol is not available.

Verify Energy Bills

The IQ 150S/250S models provide a traceable watt-hour test pulse (used with a watt-hour pulse recorder or totalizer), so you can verify the accuracy of your meter and in turn, the accuracy of billing from your utility company and to internal customers.

Integrated with Eaton's Power Xpert Architecture

IQ 150S/250S meters integrate into Eaton's Power Xpert Architecture, where meters, gateways and monitoring devices collaborate to create a unified, centralized view of the end-to-end power and facility infrastructure.

When used in this architecture, either with a Power Xpert Gateway or directly via Ethernet, the meters with the Modbus RTU option can provide Web-based graphics of current power conditions. Simply connect your meter to a Power Xpert Gateway to translate Modbus-based information from the meter into HTML-based Web pages that are accessible from any standard Web browser. If you select a model with the Ethernet option, the meter can easily be monitored remotely via Power Xpert Software or another third-party monitoring system. With access to accurate, real-time information from IQ 150S/250S meters, Power Xpert Architecture can transform your power system into an integrated, agile system, and an easily managed entity that performs better and costs less.

Designed for the User

When space is at a premium, yet you need ANSI C12.20 accuracy, Eaton IQ 150S/250S meters fit the bill. These ultra-compact meters are ideal for surface mounting next to a selected piece of equipment for energy monitoring. Requiring far less space than other meters with similar functionality, and offering a NEMA 12 enclosure and a large, easy-to-read faceplate, consistent with other Eaton meter models, these meters are designed with "knockouts" for easy retrofit installation.

Most meters in this class have small or dark displays that can be hard to see, especially from a distance. Eaton's IQ 150S/250S meters have a large, bright red, three-line LED display, each line more than a half-inch tall. This display is very easy to read, even if the meter is installed at a height or distance. Using the keypad and menus on the local display, users can display a variety of electrical system values or program the meter.

Installation Diagram

IQ 150S/250S Installation

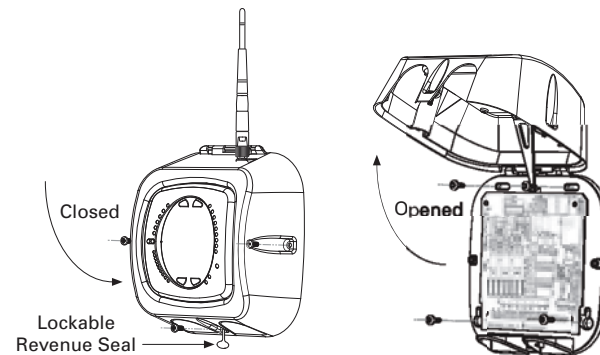

Features of IQ 150S/250S Electronic Power Meters

Features	IQ 150S	IQ 250S
Instrumentation		
Current, per phase	■	■
Calculated neutral current	■	■
Voltage, per phase (L-L, L-N)	■	■
Frequency	■	■
Minimum/maximum readings, I ^① , V ^① , PF, F, W, VAR, VA	Total	Total and per phase
Power		
Real, reactive and apparent power (W, VAR, VA)	Total	Total and per phase
Power factor	Average	Average and per phase
Demand Methods		
Block interval (fixed, sliding)	■	■
Current demand	■	■
Real, reactive and apparent power demand	Total	Total and per phase
Energy		
Real, reactive and apparent energy (Wh, VARh, VAh)	Total	Total and per phase
Real and reactive, net and positive and negative (Wh, VARh)	Total	Total and per phase
I/O		
Pulse output	■	■
Communications		
RS-485, Modbus RTU, DNP 3.0	■	■
RJ45 or 802.11b, Modbus TCP ^②	Optional	Optional
Data Logging		
2 MB for data logging		■
Alarming		
Set point driven alarm		■

Notes

- ① Per phase only.
- ② If configured for Ethernet, RS-485 not available.

Catalog Number Selection

IQ 150S/250S Meter

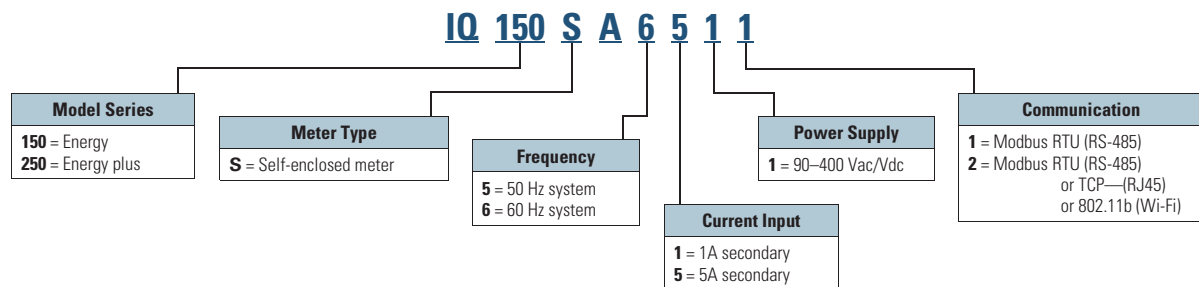

Technical Data and Specifications

IQ 150S/250S Electronic Meter Technical Information

Description	Specifications
Current Inputs	
Class 10	5A nominal, 10A maximum
Class 2	1A nominal, 2A maximum
Fault Current Withstand	
20A for:	10 seconds
60A for:	3 seconds
100A for:	1 second
Programmable current	Full scale to any CT ratio
Burden	0.005 VA per phase maximum at 11A
Pickup Current	
Class 10	0.1% of nominal
Class 2	5 mA
Class 2	1 mA
Connections	
Screw terminal	#6–32 screws
Voltage Inputs	
Range	
Line-to-neutral	20–416 Vac (IQ150S), 20–576 Vac (IQ250S)
Line-to-line	20–721 Vac
Programmable voltage range	Full scale to any PT ratio
Supported systems	3 element wye, 2.5 element wye, 2 element delta, four-wire delta systems
Input impedance	1 megohm/phase
Burden	0.36 VA/phase maximum at 600V; 0.014 VA at 120V
Connection	7-pin, 0.400-inch screw terminal block, AWG #12–26 (0.129–3.31 mm ²)
Isolation	
All inputs and outputs are galvanically isolated to 2500V	
Environmental Ratings	
Operating temperature	–20° to +70°C
Storage temperature	–20° to +70°C
Operating humidity	To 95% RH noncondensing
Faceplate rating	NEMA 12
Sensing Method	
Voltage, current	rms
Power	Sampling at over 400 samples per cycle on all channels

Description	Specifications
Update Rate	
Watts, VAR and VA	100 msec at 60 Hz
All other parameters	1 second at 60 Hz
Power Supply	
AC/DC voltage option	90–400 Vac at 50/60 Hz or 100–370 Vdc, universal AC/DC supply
Burden	16 VA maximum
Standard Serial Communications Format	
Connection type	RS-485
Communications port baud rate	9600–57,600 Bauds
Communications port address	01–247
Data format	8-bit, no parity
Protocols	Modbus ASCII, RTU, DNP 3.0
Optional Ethernet Communications Format	
Connection type	RJ45 or 802.11b (wireless)
Protocols	Modbus TCP
KYZ Pulse	
Contacts	1 Form A
On resistance, maximum	35 Ohms
Peak switching voltage	350 Vdc
Continuous load current	120 mA
Peak load current	350 mA (10 ms)
Off-state leakage current at 350 Vdc	1 uA
Opto-isolation	3750 Vac
Dimensions and Shipping	
Weight	4 lbs
Basic unit	H 7.90 x W 7.50 x D 3.10 inches
Compliance	
IEC 687	0.2% accuracy
ANSI C12.20	0.2% accuracy
ANSI C62.41	Burst
ANSI (IEEE) C37.90.1	Surge withstand
UL/cUL	Electrical and electronic measuring and test equipment 22CZ

Note: Specifications are subject to change without notice and represent the maximum capabilities of the product with all options installed. This is not a complete feature list. Features and functionality may vary depending on selected options, firmware version and product model. Please refer to User Manual for detailed specifications.

Wiring Diagrams

IQ 150S/250S Electronic Meter

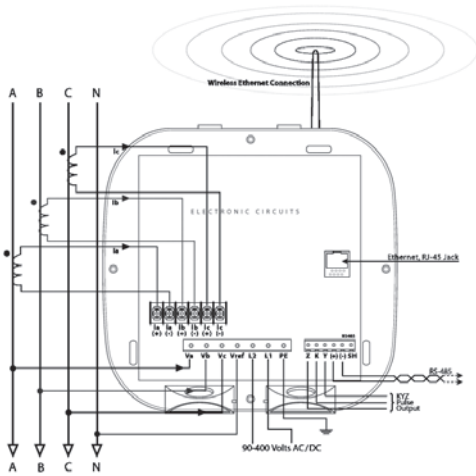

Three-Phase Four-Wire WYE Direct

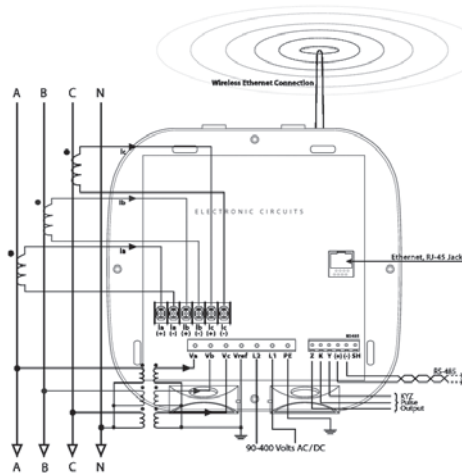

Three-Phase Four-Wire WYE with PTS

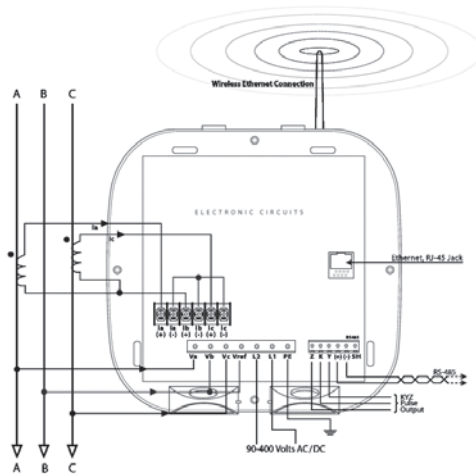

Three-Phase Three-Wire DELTA Direct

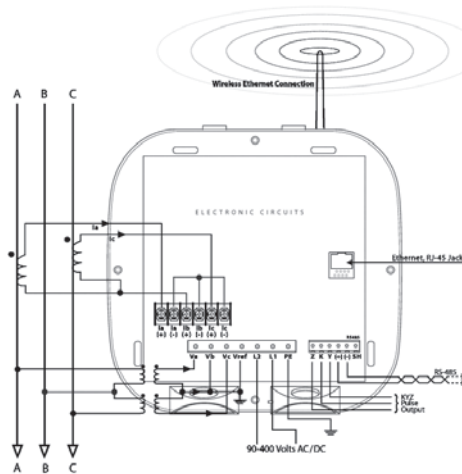

Three-Phase Three-Wire DELTA Direct

Dimensions

Approximate Dimensions in Inches (mm)

IQ 150S/250S Electronic Meter

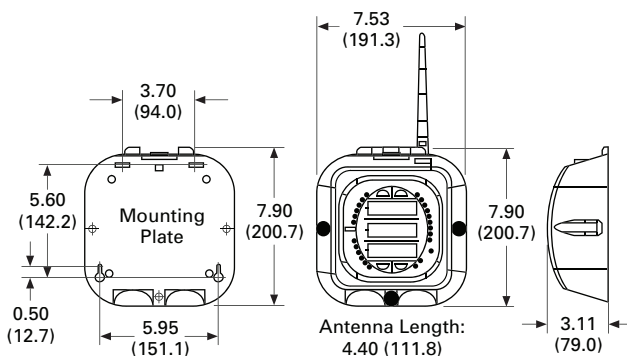

IQ 35M



Contents

Description

Metering Products Family	V3-T9-21
Power Xpert Meter 4000/6000/8000 Series	V3-T9-30
Power Xpert Meter 2000 Series	V3-T9-49
IQ 250/260 Series Electronic Power Meters	V3-T9-60
IQ 130/140/150 Series Electronic Power Meters	V3-T9-66
IQ 150S/250S Self-Enclosed Electronic Meters	V3-T9-71
IQ 35M	
Product Selection	V3-T9-77
Accessories	V3-T9-77
Technical Data and Specifications	V3-T9-77
Dimensions	V3-T9-78
IQ Analyzer 6400/6600 Series	V3-T9-79
IQ DP-4000 Series	V3-T9-87
IQ 230 Meters	V3-T9-93
Power Xpert Multi-Point Meter	V3-T9-100
IQ Energy Sentinel™	V3-T9-112
PM3 Monitoring and Metering Module	V3-T9-121
Current Transformers (CTs)	V3-T9-122
Clamp-On Current Transformers	V3-T9-131
IQ Flange	V3-T9-134
Panel Mounting Adapter Kit	V3-T9-135
Enclosed Meters	V3-T9-136

IQ 35M

Product Description

The Eaton IQ 35M Meter is a DIN rail meter that combines exceptional performance and easy installation to deliver a cost-effective solution for energy and power monitoring applications, as well as sub-metering applications. Most models include pulse output, alarm contact and phase alarms for true versatility. The BACnet version offers two digital inputs for accumulating other meter pulses in place of the digital output and alarm contact. The Modbus output options offer added flexibility for configuration and data analysis. The IQ 35M allows you to:

- Verify energy bills
- Make informed load shifting and shedding decisions
- Fairly and accurately allocate energy costs to users
- Identify wasteful practices
- Decrease unnecessary usage
- Produce an energy profile
- Secure the optimum utility rate structure

Application Description

- Commercial submetering
- Energy management
- Industrial monitoring
- Cost allocation

Features

- Economical and compact watt-hour meter with demand
- Backlit LCD display for local reading
- Compatible with the Power Xpert Gateway for remote monitoring
- Monitors
 - Voltage, current, power factor, frequency
 - Power and energy: real, reactive and apparent
- Optional data logging capability
- Optional serial communications (Modbus-RTU or BACnet)
- Revenue grade, ANSI C12.20 0.5% accuracy, IEC 62053-22 Class 0.5S
- Compatible with economical solid-core and split-core CTs
- User-enabled password protection
- On-board diagnostics

Catalog Number Selection

IQ 35M Meter

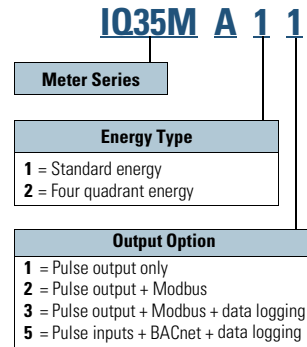

Product Selection

IQ 35M Current Transformers

Description	Catalog Number
Solid Core	
IQ35M CT, solid core, 5A:0.33 Vac, 0.30 inch	IQ35M-SO-030-5
IQ35M CT, solid core, 20A:0.33 Vac, 0.30 inch	IQ35M-SO-030-20
IQ35M CT, solid core, 50A:0.33 Vac, 0.50 inch	IQ35M-SO-050-50
IQ35M CT, solid core, 50A:0.33 Vac, 0.75 inch	IQ35M-SO-075-50
IQ35M CT, solid core, 100A:0.33 Vac, 1.25 inch	IQ35M-SO-125-100
IQ35M CT, solid core, 200A:0.33 Vac, 1.25 inch	IQ35M-SO-125-200
IQ35M CT, solid core, 250A:0.33 Vac, 1.25 inch	IQ35M-SO-125-250
IQ35M CT, solid core, 300A:0.33 Vac, 1.25 inch	IQ35M-SO-125-300
IQ35M CT, solid core, 400A:0.33 Vac, 1.25 inch	IQ35M-SO-125-400
Split Core	
IQ35M CT, split core, 5A:0.33 Vac, 0.75 inch	IQ35M-SP-075-5
IQ35M CT, split core, 30A:0.33 Vac, 0.75 inch	IQ35M-SP-075-30
IQ35M CT, split core, 50A:0.33 Vac, 0.75 inch	IQ35M-SP-075-50
IQ35M CT, split core, 100A:0.33 Vac, 0.75 inch	IQ35M-SP-075-100
IQ35M CT, split core, 200A:0.33 Vac, 0.75 inch	IQ35M-SP-075-200
IQ35M CT, split core, 250A:0.33 Vac, 1.25 inch	IQ35M-SP-125-250
IQ35M CT, split core, 300A:0.33 Vac, 1.25 inch	IQ35M-SP-125-300
IQ35M CT, split core, 400A:0.33 Vac, 1.25 inch	IQ35M-SP-125-400
IQ35M CT, split core, 600A:0.33 Vac, 1.25 inch	IQ35M-SP-125-600
IQ35M CT, split core, 800A:0.33 Vac, 2.50 inch	IQ35M-SP-253-800
IQ35M CT, split core, 1000A:0.33 Vac, 2.50 inch	IQ35M-SP-255-1000
IQ35M CT, split core, 1200A:0.33 Vac, 2.50 inch	IQ35M-SP-255-1200
IQ35M CT, split core, 1600A:0.33 Vac, 2.50 inch	IQ35M-SP-255-1600
IQ35M CT, split core, 2000A:0.33 Vac, 2.50 inch	IQ35M-SP-255-2000
IQ35M CT, split core, 2400A:0.33 Vac, 2.50 inch	IQ35M-SP-255-2400

Accessories

IQ 35M Accessories

Description	Catalog Number
IQ35M enclosure, NEMA 4X	IQ35M-ENC
IQ35M fuse pack, single, 1/2A slow-blow	IQ35M-FP1
IQ35M fuse pack, double, 1/2A slow-blow	IQ35M-FP2
IQ35M fuse pack, triple, 1/2A slow-blow	IQ35M-FP3
IQ35M replacement mounting clips	IQ35M-RMC
IQ35M DIN rail	IQ35M-DR
IQ35M DIN rail stop clips (10 pack)	IQ35M-DRSC

Note: Specifications are subject to change without notice and represent the maximum capabilities of the product with all options installed. This is not a complete feature list. Features and functionality may vary depending on selected options, firmware version and product model. Please refer to User Manual for detailed specifications.

Technical Data and Specifications

- Voltage input
UL: 90V (L-N) to 600V (L-L)
CE: 90V (L-N) to 300V (L-L)
- Current input
Scaling: 5–32,767A
Input range: 0–0.333V or 0–1V (selectable)
- Control power
UL: 90V (L-N) to 600V (L-L)
CE: 90V (L-N) to 300V (L-L)

Accuracy

- Real power and energy
0.5% (ANSI C12.20, IEC 62053-22 Class 0.5S)

Outputs

- IQ35MAx1 thru 3:
Real energy pulse: NO static; alarm contacts: NC static
- IQ35MA11
Reactive energy pulse 30 Vac/Vdc
- IQ35MAx2, IQ35MAx3
RS-485 two-wire Modbus RTU
- IQ35MA15 RS-485 two-wire BACnet MS/TP

Inputs

- IQ35MA15
Two pulse accumulators

Mechanical

- Mounting
DIN rail or 3-point screwmount

Environmental

- Operating temperature range
Meter: –30° to 70°C (–22° to 158°F)
Display: –10° to 50°C (14° to 122°F)
- Storage temperature range
Meter: –40° to 85°C (–40° to 185°F)
Display: –10° to 60°C (14° to 140°F)
- Humidity range
<95% RH noncondensing

Data Outputs

- kW, kWh: Total
- Current: Three-phase average and per phase
- Voltage: Three-phase average, per phase, and line-line and line-neutral
- Power: Real, reactive and apparent;
Three-phase total and per phase
- Power factor: Three-phase average and per phase
- Frequency
- Power demand: most recent and peak
- Demand configuration: fixed, rolling block and external sync
- Data logging (IQ35MAx3)
10 configurable data buffers;
configurable demand subinterval (when set at a 15-minute interval, buffers store data for 60 days)
- Data logging (IQ35MA15)
6 configurable data buffers;
configurable demand subinterval (when set at a 15-minute interval, buffers store data for 60 days)
- Trending requires communication network to retrieve data

Dimensions

Approximate Dimensions in Inches (mm)

IQ 35M Dimensional Drawing

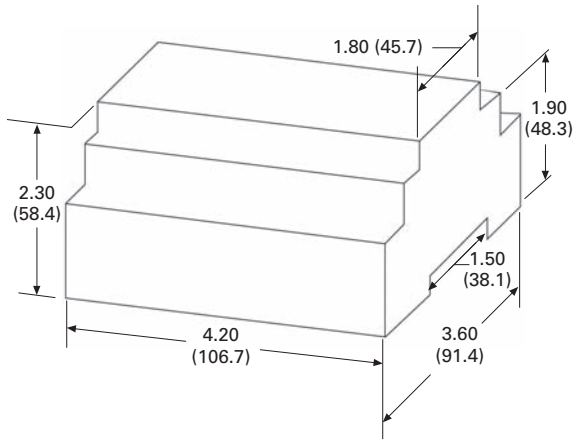

IQ 35M Wall Mount Configuration

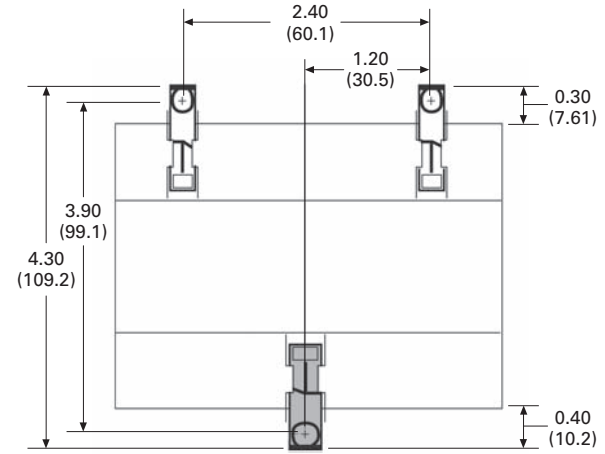

IQ 35M DIN Mount Configuration

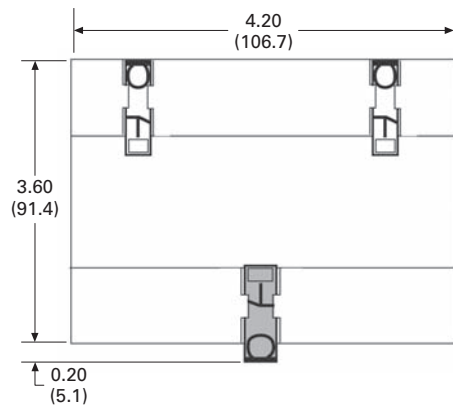

IQ Analyzer 6400/6600 Series



**IQ Analyzer—
Comprehensive Electrical
Distribution Monitoring**

IQ Analyzer 6400/6600 Series

Product Description

Eaton’s IQ Analyzer is a complete solution for users who want to monitor and manage all aspects of their electrical distribution system. Based on input from customers and consultants, it provides extensive metering, power quality analysis, remote input monitoring, control relaying, analog input/outputs and communications capability.

Its high performance metering exceeds ANSI C12.16 (1%) specification for revenue meters and meets ANSI C12.20 Class 0.5%, provides quality true rms readings through the 50th harmonic, accurately measures nonsinusoidal waveforms up to a 3.0 crest factor, and displays even and odd multiples of the fundamental current and voltage through the 50th harmonic. Both magnitude and phase angle of the harmonics are displayed.

The unique operator interface, which includes a reverse mode LCD display, easy to use *Meter Menu* screens and detailed *Analysis* screens, is designed to allow a wealth of real-time and recorded information to be accessed easily by an operator. All programming can be accomplished through the faceplate or the communications port. The comprehensive on-line Help feature provides useful information on device operation, programming and troubleshooting.

Application Description

- Monitoring of over 150 electrical parameters
- Power quality management
- Energy management

Contents

<i>Description</i>	<i>Page</i>
Metering Products Family	V3-T9-21
Power Xpert Meter 4000/6000/8000 Series	V3-T9-30
Power Xpert Meter 2000 Series	V3-T9-49
IQ 250/260 Series Electronic Power Meters	V3-T9-60
IQ 130/140/150 Series Electronic Power Meters	V3-T9-66
IQ 150S/250S Self-Enclosed Electronic Meters	V3-T9-71
IQ 35M	V3-T9-76
IQ Analyzer 6400/6600 Series	
Standards and Certifications	V3-T9-82
Product Selection	V3-T9-83
Accessories	V3-T9-83
Technical Data and Specifications	V3-T9-84
Dimensions	V3-T9-85
IQ DP-4000 Series	V3-T9-87
IQ 230 Meters	V3-T9-93
Power Xpert Multi-Point Meter	V3-T9-100
IQ Energy Sentinel™	V3-T9-112
PM3 Monitoring and Metering Module	V3-T9-121
Current Transformers (CTs)	V3-T9-122
Clamp-On Current Transformers	V3-T9-131
IQ Flange	V3-T9-134
Panel Mounting Adapter Kit	V3-T9-135
Enclosed Meters	V3-T9-136

Features, Benefits and Functions

Metered and Monitored Parameters

- rms sensing
- Phase neutral, and ground currents
- Volts: L-L, L-N, Avg. L-L, Avg. L-N, N-G
- Power: real, reactive, apparent (system and per phase)
- Frequency
- Power factor: apparent and displacement (system and per phase)
- Energy and demand (forward, reverse, net) real, reactive apparent at four different utility rates
- Individual current and voltage harmonics: magnitude, phase angle
- % THD: current and voltage
- Waveform capture

- Minimum and maximum values
- Event logging/disturbance recording
- ANSI C12.20 Class 0.5% revenue metering accuracy, IEC687 Class 0.5%
- Industry Canada 0.5% revenue accuracy

Communications

- Optional interface capability to computer network for data collection, storage and/or printout via Eaton’s Power Management Software

Physical Characteristics

- Graphical reverse mode LCD display with LED backlight
- Up to seven lines of information
- Membrane faceplate NEMA 3R and 12 rated

Disturbance Information

With the communications option and Eaton's Power Management Software and Waveform Display software, a *Waveform Analysis* will construct waveforms of up to 56 cycles of all currents and voltages (including neutral and ground) to help troubleshoot undervoltage/sag and overvoltage/swell conditions. (See CBEMA Trend Logging section.)

By programming a reset threshold, the duration of the voltage disturbance can also be indicated.

The IQ Analyzer 6600 series with Graphic Waveform Display offers the ability to view the captured waveform right at the device. The 6600 series also offers the ability to detect and capture sub-cycle voltage disturbances.

Extensive Harmonic Distortion Analysis

Current and voltage distortion data are displayed at the device and accessible through the communications port. This includes % THD, K-Factor, Crest Factor, CBEMA factor, and both magnitudes and phase angles of all harmonics through the 50th. A snapshot sample of this information may be activated by user commands, discrete inputs or programmable thresholds to capture distortion data during conditions of real interest. To help eliminate nuisance alarms, harmonic distortion information can be captured and relay outputs activated when THD exceeds a programmable percentage of fundamental or a programmable magnitude (e.g., amperes) threshold.

Time-of-Use Metering

The IQ Analyzer offers the ability to store energy usage data for time of use revenue metering. It can be programmed for any combination of weekday, Saturday, Sunday, 22 holidays, 8 seasons,

32 schedules and 10 time periods per schedule. The IQ Analyzer will keep track of the following parameters for four different utility rates:

- Watthours
- VAR hours
- VA hours
- Current demand
- Watt demand
- VA demand
- VAR demand

Historical Trend Logging

The IQ Analyzer is equipped with onboard logging capability, which includes the ability to log a total of 24 parameters with intervals ranging from 0.13 seconds (every eight cycles) to twice a week (5040 minutes). The trending function can begin immediately or can be triggered upon receipt of a discrete input into the IQ Analyzer. Onboard logging provides a cost-effective means of distributed data storage where real-time communications may not be feasible or for applications where data storage redundancy is desired. Four trend data logs are stored in non-volatile memory aboard the IQ Analyzer and can be retrieved at the display or via communications for viewing using Eaton's Power Management Software.

- Up to 24 parameters with storage capacity for up to 90,000 data points
- Up to 234 days of data can be stored when recording a parameter every 15 minutes
- Trends 1, 2 and 3 can save data on a discrete contact input
- Trend 4 can save data on a power quality or meter event
- Minimum and maximum recording (minimum and maximum three-phase average current, maximum I_G , minimum and maximum three-phase average V_{LL} and V_{LN} , maximum V_{NG} , maximum

system watts, VARs and VA, minimum and maximum apparent and displacement PF). Using this feature, minimum and maximums reached during each trend interval are recorded.

CBEMA Trend Logging

The IQ Analyzer can be configured to store the necessary data so that the software can display a sag or swell voltage event on the industry standard CBEMA (now ITIC) curve for predictive maintenance and troubleshooting. This application utilizes the IQ Analyzer waveform capture for high-speed events along with historical trend logging for longer term voltage disturbances. Once this data is uploaded to a PC running the Power Management Software's Event Viewer the information is analyzed, displayed and stored. Automatic uploading of CBEMA events can be selected in the software. A three-phase event will be correctly displayed as a single point on the CBEMA curve.

Event Logging

The IQ Analyzer will store in non-volatile memory the time and reason for last 504 events. These events can be viewed from the graphical display or accessed via communications. In addition to all of the meter events listed in the Event Conditions section (**Page V3-T9-81**), the following events are entered into the event log:

Time and date of:

- Alarms
- Meter power up
- All resets
- All setting changes
- Communications established or lost

Event logging is another powerful troubleshooting tool within the IQ Analyzer.

Extensive I/O and Communications Capability

One analog and three digital inputs are provided to interface with sensors and transducers. Three analog outputs and four relay contacts are furnished to share data with PLCs and control systems and to actuate alarms and control relays. Terminals are captive clamp type and finger safe. With the communications option, the device can be remotely monitored, controlled and programmed.

Ratings

- Application to 500 kV, no PTs to 600 volts
- CT ratios selectable from 5:5A to 10,000:5A
- Standard 120/600 Vac line
- Three-phase power supply module, 100–600 Vac. Separate source power supply module available, 100–240 Vac or 100–250 Vdc
- DC only separate source power module also available, 24–48 Vdc

Displayed Information Features

- All information accessible at device or through communications port via Eaton's Power Management Software
- Quality true rms readings through 50th harmonic
- Complies with the accuracy portion of ANSI C12.20 Class 0.5% revenue metering specification
- Accurate readings for nonsinusoidal waveforms with up to 3.0 crest factor
- Screens display auto ranging units, kilo units, mega units as needed
- 10-digit energy readings
- Displays multiple parameters at the same time
- Programmable custom screens

Meter Menu Screens



Meter Menu

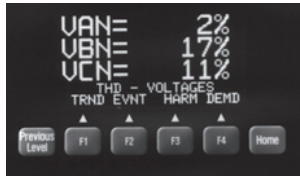

Examples of Meter Menu



Custom Screen



Custom Screen

The IQ Analyzer allows a user to view commonly used parameters by scrolling through its LED indicator Meter Menu.

Meter Menu Displayed Information

- Current
 - Phases A, B, C, average
 - Neutral
 - Ground (separate CT)
- Voltage
 - Phases A-B, B-C, C-A, average
 - Phases A-N, B-N, C-N, average
 - Neutral-ground
- Power
 - Real (watts)
 - Reactive (VARs)
 - Apparent (VA)
 - Phases A, B, C and system

- Energy (forward, reverse and net)
 - Real (kWh)
 - Reactive (kVARh)
 - Apparent (kVAh)—no reverse or net
- Frequency, time and date
- Demand
 - System current (amperes)
 - Systems real power (kW)
 - System reactive power (kVAR)
 - System apparent power (kVA)
- Power factor (Phases A, B, C and system)
 - Displacement
 - Apparent
- %THD current
 - Phases A, B, C, N
- %THD voltage
 - Phases A-B, B-C, C-A
 - Phases A-N, B-N, C-N
- K-factor
- CBEMA (ITIC) derating factor (displayed as “Z”)
- Crest Factor
- Discrete input and output status
- Analog input reading
- Custom—user may program four screens to show any combination of seven Meter Menu parameters per screen

Harmonic Analysis Screens

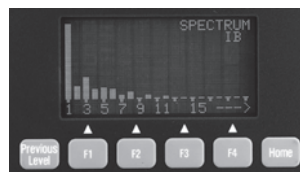

Harmonic Spectrum Available with Model 6600

Minimum and Maximum Values

- Current
 - Phases A, B, C, N, G
- Voltage
 - Phases A-B, B-C, C-A
 - Phases A-N, B-N, C-N, N-G

- Power
 - Real (Watts)
 - Reactive (VARs)
 - Apparent (VA)
 - Phases A, B, C and System
- Power factor
 - Apparent and Displacement (three-phase and system)
- Frequency
- THD (amperes, volts and %):
 - Current (Phases A, B, C, N)
 - Voltage (Phases A-B, B-C, C-A, A-N, B-N, C-N)

All minimum/maximum values may be reset via reset pushbutton on faceplate, discrete input or communications command. Values are updated at least once every 16 line cycles.

The F3 function key accesses the Harmonic Analysis screens. Two cycles of data sampled at 128 **samples/cycle** are **simultaneously** recorded for:

- Current
 - Phases A, B, C, N, G
- Voltage
 - Phases A-B, B-C, C-A
 - Phases A-N, B-N, C-N
 - Neutral to Ground

Magnitudes (or % of fundamental) of odd **and even** multiples of the fundamental from 2nd–50th are displayed. The phase angle associated with each multiple of the fundamental is also displayed.

Event/Alarm Analysis Screens

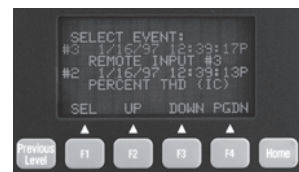

Example of Event Analysis Screens

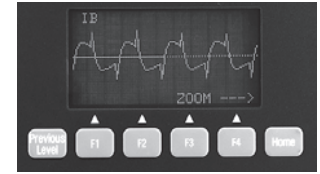

Waveform Screen Available with Model 6600

Pressing the F2 function key accesses the Event Analysis screens. These display the following data for up to ten event/alarm conditions:

- Description, date and time of event/alarm with 10 millisecond resolution
- Current, voltages, power readings, demand readings, frequency and % THD at time of event/alarm
- Current and voltage distortion information available on Harmonic Analysis screens

Event data is stored in non-volatile memory. If a reset threshold is programmed, the *duration* of the event (e.g., undervoltage) is also displayed. With Eaton’s communications option and software, waveforms and harmonic profiles may be displayed on a PC.

Event Conditions

Events may be triggered by up to seven of any of the following conditions:

Voltage Disturbances

- Undervoltage/sag—any V_{LL} , V_{LN} (40–100%)

Note: 60% minimum for self-powered unit.

- Overvoltage/swell—any V_{LL} , V_{LN} (100–750%)

If zero time delay is programmed, any disturbance lasting two cycles (less if magnitude is sufficient to effect rms readings) will trigger a voltage disturbance event/alarm.

- Sub-cycle transient capture/excess dv/dt on V_{A-N} , V_{B-N} , V_{C-N}

Note: 6600 series only.

- Sub-cycle voltage interruption on V_{A-N} , V_{B-N} , V_{C-N}

Note: 6600 series only.

Maximum Threshold Exceeded

- Currents—phases A, B, C, Neutral and Ground
- Voltage—Neutral to Ground
- System Power—Watts, VA, VARs
- System Power Factor—Displacement and Apparent
- Demand
- Currents—Phase A, B, C and AVG
- System Power—Watts, VARs, VA
- Frequency
- Percent Total Harmonic Distortion or Magnitude Total Harmonic Distortion:
 - Currents—Phases A, B, C, Neutral
 - Voltage— V_{A-N} , V_{B-N} , V_{C-N} , V_{A-B} , V_{B-C} , V_{C-A}

Minimum Threshold Exceeded

- Currents—Phases A, B, C
- System Power—Watts, Vars, VA
- System Power Factor—Displacement and Apparent
- Frequency

Voltage Phase Unbalance

- Voltage L-L, L-N

Current Phase Unbalance

- Current—Phases A, B, C

Discrete Input Energized

- Input 1, 2, 3
- Remote command through communications port or front panel

All trigger conditions have programmable time delays from 0.1–60 seconds in 0.1 second increments (except Voltage Disturbances—programmable from 2–3600 cycles in two-cycle increments, and Eaton's Power Management Software commands—no programmable delay).

Demand Recording

Peak Demands are date and time stamped for:

- Current Phases A, B, C and Average
- System Power:
 - Real (watts)
 - Reactive (VARs)
 - Apparent (VA)

Input/Output

Extensive input/output capability is standard on the IQ Analyzer. In addition to monitoring three-phase currents and voltages, separate inputs are provided for both ground and neutral currents. Voltage of neutral-to-ground is also monitored to indicate the presence of harmonics and potential downstream grounding problems. Analog and digital I/O provide interfaces for transducers, relays, PLCs and control systems.

Current Inputs

Five ampere secondary CT connections for:

- Phases A, B, C
- Ground
- Neutral
- Separate ground and neutral CT inputs
- CT range 5:5–10,000: 5 (any integer)

Voltage Inputs

- Phases A, B, C (from 120 Vac–500 kV AC)
- 120/240 Vac control power input standard—not required with optional line power module
- Separate ground-to-neutral voltage reference
- PT range 120:120–500,000:120 (any integer)

External 120-volt secondary PTs are required above 600 Vac, optional from 120–600 Vac.

Discrete Contact Inputs

Three dry contact discrete inputs may be programmed by the user to:

- Trigger Event Analysis—the information described in “Event Analysis Screens,” including Harmonic Analysis information, can be recorded when external devices trip or change state by wiring their auxiliary contacts into these inputs
- Act as a synch.-pulse input to synchronize power demand windows with utility provided synch. pulse
- Actuate a relay output
- Reset relay output, peak demands, Trend Analysis records and Event Analysis records
- With communications option, provide remote status indication on Eaton's communication network
- Status of input contacts is displayed in the Meter Menu Custom screen

Relay Output Contacts

Four Form-C (NO/NC) relay contacts may be independently programmed to:

- Act as a kWh, kVARh or kVAh pulse initiator output
- Actuate on one or more event conditions—including discrete input software commands (through communications port)
- Reverse sequence alarm

Each relay may be set for Auto or Manual Reset with 0–30 minute release delay (one second increments). Relays are Form-C NO/NC. Relay(s) programmed to actuate on undervoltage also have a programmable 0–30 minute delay on power-up for transfer applications.

Analog Input and Outputs

One analog input and four analog outputs may be configured as 0–20 or 4–20 mA. The analog input is displayed at the device as a percentage and is accessible through the communications port. The analog input provides an interface with gas flow meters, temperature transducers or other analog devices.

The analog outputs may be programmed to reflect any of the following:

- Current—Phases A, B, C, Average, N, G
- Voltage—L-L, L-N, N-G
- Power:
 - Real (watts)
 - Reactive (VARs)
 - Apparent (VA)
 - Phases A, B, C and System
- % THD:
 - Current (Phases A, B, C, N)
 - Voltage (L-L, L-N)
- Frequency—System
- Power Factor:
 - System Displacement PF
 - System Apparent PF

Standards and Certifications

- UL listed, File E62791, NKCR File E185559 (CE versions)
- cUL listed #1010.1 C22.2
- CE mark EN61010-1 (1993) EN50082-2 (1994)
- Measurement Canada Electricity Meter AE-0782
- CSA approved



Product Selection

IQ Analyzer



IQ Analyzer

Description	Catalog Number
IQ Analyzer, separate source power module	IQA6410
IQ Analyzer, 24–48 Vdc power module	IQA6420
IQ Analyzer, three-phase power module	IQA6430
IQ Analyzer, separate source power module with waveform display and sub-cycle voltage disturbance capture	IQA6610
IQ Analyzer, 24–48 Vdc power module with waveform display and sub-cycle voltage disturbance capture	IQA6620
IQ Analyzer, three-phase power module with waveform display and sub-cycle voltage disturbance capture	IQA6630
IQ Flange, to provide extra clearance when mounting	IQFLANGE
45-inch (1143.0 mm) extension cable for remote mounting of power module	IQA45CABLE
24–48 Vdc separate source power module	IQMDCPM
100–240 Vac and 100–250 Vdc separate source power module	IQMSSPM
Three-phase, self-powered power module	IQM3PPM
INCOM communication module	IPONI
RS-485 communication module with Modbus protocol	MPONI

Accessories

IQ Analyzer Auxiliary Power Supply

The optional IQ Analyzer Auxiliary Power Supply allows set point programming of the IQ meter while the monitored line power is turned off and locked out, thus eliminating the presence of dangerous line voltages. The Auxiliary Power Supply is easy to install and has been specifically designed to connect to the power supply connector on the IQ meter and then plug into a standard electrical wall outlet.

Technical Data and Specifications

IQ Analyzer 6400/6600 Series

Fuses

- Self-powered units with IQMSSPM have 3/4 ampere, 600 volts Bus Type KTK-R-3/4 fuses (three required).
- Separate source dual-voltage units with IQMSSPM have a single 5 x 20 mm 1/4 ampere fuse
- Separate source DC units with IQMDCPM do not have user replaceable fuses

Environmental Conditions

- Operating temperature: -20°–70°C
- Storage temperature: -30°–85°C
- Operating humidity: 5–95% relative humidity

Current Inputs (Each Channel)

- Conversion: true rms, 32 sample/cycle (all samples used in all rms calculations)
- CT input: 5 ampere secondary (any integer 5:5 to 10,000:5)
- Burden: 0.05 VA
- Overload withstand: 40 amperes AC continuous, 300 amperes AC 1 second
- Range: 8 x CT continuous
- Accuracy: 0.1% of CT primary rating, 0.2% of reading above 150% of rating, sinusoidal (see accuracy below for non-sinusoidal specifications)
- Input impedance: 0.002 ohm

Voltage Inputs (Each Channel)

- Conversion: True rms, 32 sample/cycle (all samples used in all rms calculations)
- PT input: direct or any integer 120:120–500,000:120
- Range: 30–660 Vac (separate source and DC source)
- Nominal full scale: 100–600 Vac
- Burden: 21 VA (self-powered only)
- Overload withstand: 635 Vac, continuous 700 Vac, 1 second
- Input impedance: 1 megohm

Frequency Range

- 20–66 Hz fundamental (up to 50th harmonic)

Harmonic Response (Voltages, Currents)

- 50th harmonic

Accuracy (in Percent Full Scale)

Accuracy from 3–300% of Full Scale and from -0.5. to 1.00 to 0.5 power factor

- Current and voltage: ±0.20%
- Power, energy and demand: 0.40%
- Frequency: 0.04%
- Power factor: 0.80%
- THD: 1.00%

Specific Current Accuracies

- ±0.20% of full scale to 200% of full scale and 150% crest factor
- ±0.20% of full scale to 150% of full scale and 200% crest factor
- ±0.20% of full scale to 100% of full scale and 300% crest factor
- ±0.40% of reading for currents to 800% of full scale
- Power and energy: Start recording with an average of 3 mA secondary current

Discrete Inputs (Dry Contact)

- +30 Vdc differential across each discrete input pair of terminals. Minimum pulse width: 1.6 msec
- Optically isolated inputs to protect IQ Analyzer circuitry

Analog Outputs (4)

- 0–20 mA/4–20 mA into maximum 750 ohm load. Accuracy: 1%

Analog Input (1)

- 0–20 mA/4–20 mA into 200 ohm load. Accuracy: 1%

Relay Output Contacts (4)

- Form C Dry Contact: 10 amperes at 120/240 Vac (Resistive) 10A at 30 Vdc (Resistive) 30A make (50 mS) at 240 Vac/240 Vdc
- Minimum pulse width: 4 cycles (68 mS)

- Withstand rating: 1000 Vac, 1 minute across contacts 5000 Vac (contacts to coil, 1 minute) 10,000 Vac (contacts to coil, surge voltage)

Relay Response Time

(Excluding programmed time delays):

- Two line cycles for Discrete Input, Eaton's software commands (communications port)
- Four to five line cycles for Voltage Disturbance, Voltage Unbalance
- Nine to ten line cycles for all others

IQ Analyzer Auxiliary Power Supply

- Input voltage: 100–250 Vac
- Input frequency: 50/60 Hz
- Output voltage/current: +24 Vdc at 0–0.45A
- Output ripple: 100 mV maximum (peak to peak)
- Rated output power: 10.8 watts
- Turn on/turn off overshoot 5% maximum
- Turn on delay: 0.5 second maximum
- Operating temperature: 0°–40°C
- Storage temperature: -40°–80°C

Control Power Input

Description	Separate Source	Self Powered ^①	DC Source
Input range, AC	110–240 Vac ±10%	110–600 Vac ±10%	N/A
Frequency range	45–66 Hz	45–66 Hz	N/A
Input range, DC	110–250 Vdc ±10%	N/A	24–48 Vdc ±20%
Burden	21 VA	21 VA	21 VA

Note

① When directly wired to 480 Vac, IQ Analyzer can ride through a continuous sag that is 20% of rated voltage.

Wiring Diagram

Field Wiring Connections—Separate Source Power Supply Shown Here
(For Three-Phase Power Supply, No Separate Control Power is Required)

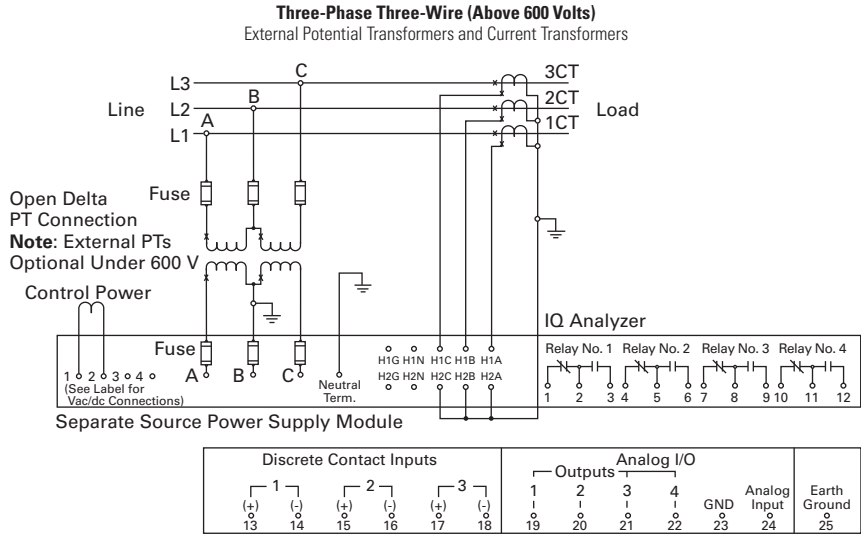

Dimensions

Approximate Dimensions in Inches (mm)

IQ Analyzer 6000 Series

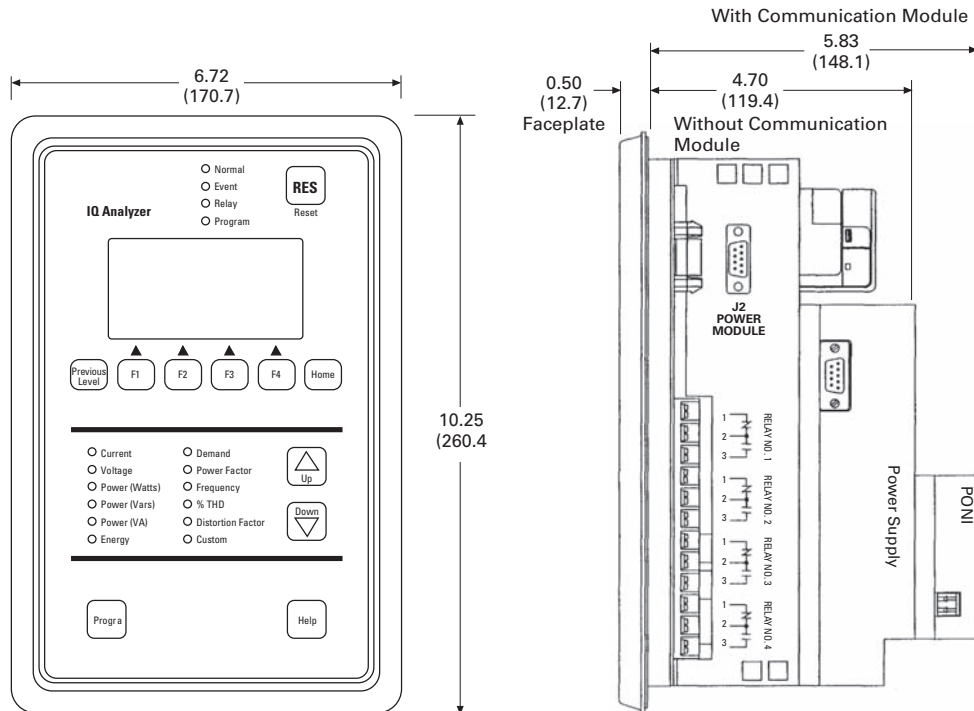

9.3

Metering Devices, Protective Relays, Software and Connectivity

Metering Devices

Approximate Dimensions in Inches (mm)

IQ Analyzer Auxiliary Power Supply

Width	Height	Depth	Shipping Weight Lbs (kg)
2.40 (61.0)	4.00 (101.6)	1.11 (28.2)	5.8 (3.6)

IQ Analyzer 6000 Series

Height	Width	Depth
Without PONI		
10.25 (260.4)	6.72 (170.7)	4.70 (119.4)
With PONI		
10.25 (260.4)	6.72 (170.7)	5.83 (148.1)

Drilling Pattern

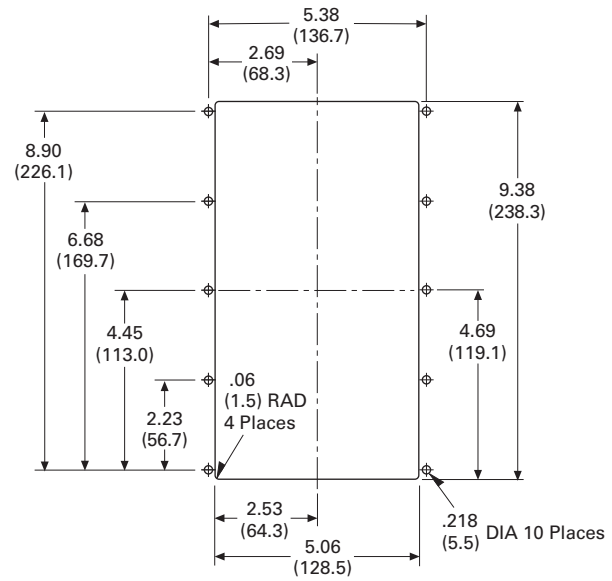

Drilling Pattern for Flange Mounting

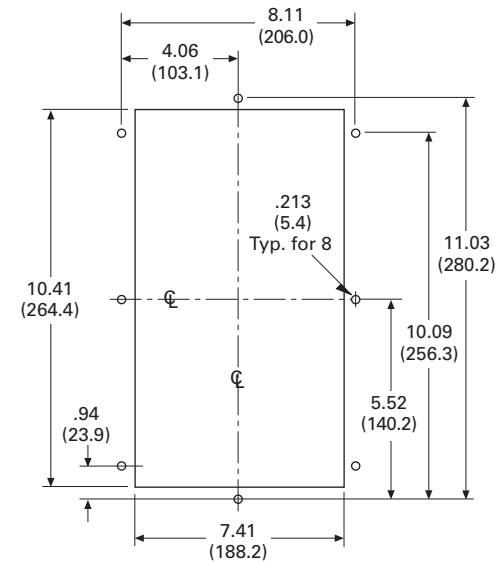

IQ DP-4000



IQ DP-4000 Series

Product Description

Eaton’s IQ DP-4000 is a microprocessor-based monitoring and protective device that provides complete electrical metering and system voltage protection. In one compact, standard package, the IQ DP-4000 will provide an alternative to individually mounted and wired conventional meters and switches. The DP-4000 also monitors Apparent Power (VA), Reactive Energy (VAR-hours), Apparent Energy (VA-hours) and percent THD to provide the user with basic power quality information. The IQ DP-4000 meets and surpasses UL/CSA/CE standards.

The IQ DP-4000’s rugged construction is designed to withstand harsh conditions such as temperature variations, outdoor applications and industrial environments. The membrane faceplate pushbuttons are easy to use and both the parameter LED and window displays are easily visible.

Application Description

- Monitoring of all common electrical parameters
- Optional protective alarm functions

Retrofit Opportunities

- Retrofit of existing electrical distribution systems with the IQ DP-4000 for power, quality, load and energy monitoring
- Mounting flange option for application where additional door mounting space is required; see **Page V3-T9-134**

Contents

Description

	<i>Page</i>
Metering Products Family	V3-T9-21
Power Xpert Meter 4000/6000/8000 Series	V3-T9-30
Power Xpert Meter 2000 Series	V3-T9-49
IQ 250/260 Series Electronic Power Meters	V3-T9-60
IQ 130/140/150 Series Electronic Power Meters	V3-T9-66
IQ 150S/250S Self-Enclosed Electronic Meters	V3-T9-71
IQ 35M	V3-T9-76
IQ Analyzer 6400/6600 Series	V3-T9-79
IQ DP-4000 Series	
Features, Benefits and Functions	V3-T9-88
Standards and Certifications	V3-T9-88
Product Selection.	V3-T9-89
Accessories	V3-T9-89
Technical Data and Specifications	V3-T9-90
Dimensions	V3-T9-92
IQ 230 Meters	V3-T9-93
Power Xpert Multi-Point Meter	V3-T9-100
IQ Energy Sentinel™	V3-T9-112
PM3 Monitoring and Metering Module	V3-T9-121
Current Transformers (CTs).	V3-T9-122
Clamp-On Current Transformers	V3-T9-131
IQ Flange	V3-T9-134
Panel Mounting Adapter Kit	V3-T9-135
Enclosed Meters.	V3-T9-136

Features, Benefits and Functions

Historical Values

- Present demand current (per phase) 5, 10, 15, 20, 25, 30, 45 or 60 minute windows
- Present demand watts, VARs and VA 5, 10, 15, 20, 25, 30, 45 or 60 minute windows:
 - Sliding or fixed window for power Sync pulse input (Model 4100) Eaton's PowerNet broadcast demand sync
- Minimum and maximum values current (per phase):
 - Voltage (per phase, L-L, L-N)
 - Watts, VARs and VA
 - Power factor (displacement and apparent)
 - Frequency
- Peak values:
 - Percent THD parameters
 - Demand parameters

Protective and Event Alarming

- Undervoltage
- Overvoltage
- Current phase loss
- Voltage phase loss
- Phase reversal
- Phase unbalance
- Optional current and powerdemand threshold

Metered and Monitored Parameters

- rms sensing
- Phase currents
- Volts: L-L, L-N
- Power: real, reactive, apparent
- Energy: real, reactive, apparent
- Frequency
- Power factor
- % THD: current and voltage
- Minimum and maximum values
- Fixed or sliding demand windows

Communications

- Optional interface capability to computer network for data collection, storage and/or printout via Eaton's Power Management Software

Physical Characteristics

- Large visible LED display
- Membrane Faceplate NEMA 3R and 12 rated

Alarm and Protective Functions

- Alarm/Protective functions (all models) include:
 - Overvoltage
 - Undervoltage
 - Current phase loss
 - Voltage phase loss
 - Phase unbalance
 - Phase reversal
- User-programmable alarm and reset threshold levels and delay intervals
- Optional current and power demand threshold

Description of Protection Functions

Overvoltage

Range 105–140% (5% increments).

Undervoltage

Range 60–95% (5% increments).

Phase Unbalance

Deviation between any two phases percentage of nominal line voltage preset by DIP switches. Range 5–40% (5% increments).

Phase Reversal

Any two phases become reversed for the selected delay.

Voltage Phase Loss

Less than 50% of the nominal line voltage detected.

Current Phase Loss

Smallest phase current is less than 1/16 of the largest phase current.

Delay

Allows a delay before an alarm occurs. (Range 1–20 seconds in 1 second increments.)

Note: Unit must be powered for this to occur.

Inputs and Outputs (4100 Model)

- Three Form C relay outputs selectable: Trip, Alarm, kWh pulse initiator
- One synch input for kW utility demand sync

Standards and Certifications

Listings and Certifications

- UL/cUL/CSA listed
- CE mark EN61010-1, EN50082-2



Product Selection

IQ DP-4000

IQ DP-4000



Description

Description	Catalog Number
4 indicates an IQ DP-4000 model	IQDP4XY0
x = 0 indicates no I/O; x = 1 indicates I/O	
y = 1 indicates separate source supply, 110–240 Vac and 110–250 Vdc	
y = 2 indicates 24–48 Vdc power supply,	
y = 3 indicates three-phase power supply, 110–600 Vac	
Separate source control power without I/O	IQDP4010
Separate source control power without I/O, DC supply	IQDP4020
Three-phase power supply without I/O	IQDP4030
Separate source control power with three Form C relay output contacts and one sync pulse input	IQDP4110
Separate source control power with three Form C relay output contacts and one sync pulse input, DC supply	IQDP4120
Three-phase power supply with three Form C relay output contacts and one sync pulse input	IQDP4130
2 Form C relay outputs for protective alarming functions, 1 Form C relay output selectable for KYZ pulse output or load shedding, 1 demand sync pulse input	DP410MOD
IQ flange, to provide extra clearance when mounting	IQFLANGE
45-inch (1143.0 mm) extension cable for remote mounting of power module	IQA45CABLE
24–48 Vdc separate source power module	IQMDCPM
100–240 Vac and 100–250 Vdc separate source power module	IQMSSPM
Three-phase, self-powered power module	IQM3PPM
INCOM communication module	IPONI
RS-485 communication module with Modbus protocol	MPONI

Accessories

IQ DP-4000 I/O Module

For applications where field modification to add or change Input/Output (I/O) capability to the IQ DP-4000 is required, Eaton offers I/O cards. These field-installable modules can be easily inserted into an existing IQ DP-4000 where input/output application needs change.

- Power requirements: 10 VA
- Frequency: 50/60 Hz
- Operating temperature: 25°–70°C
- Operating humidity: 0–95% noncondensing
- Dry contact input: 24 Vdc differential across input pair of terminals; minimum pulse width, 50 mS

Technical Data and Specifications**Accuracy**

- Maintained from 10–250% of CT primary rating

Current Inputs (Each Channel)

- Nominal full scale current: 5 amperes AC
- Current range for rated accuracy: 0–15 amperes AC
- Overload withstand: 15 amperes ac continuous 300 amperes AC 1 second
- Burden: 0.003 VA

Voltage Inputs (Each Channel)

- Voltage range (nominal): 90–600 Vac
- Nominal full scale voltage: 120–600 Vac
- Overload withstand: 660 Vac continuous 4 kV 1.2/50 μ s
- Burden: three-phase power module 10 VA

Fuses

Supplied with three-phase power module only. 3/4 ampere, 600 volt bus type KTK-R-3/4 (three required).

Contact Rating (Model 4100)

- 10 amperes at 120/240 Vac (resistive)
- 10 amperes at 30 Vdc (resistive)

Compatible with the Following Systems

- Three-phase, three-wire
- Three-phase, four-wire

Ratings

- Application to 500 kV, no PTs to 600 volts
- CT ratios selectable from 5:5 A to 12800: 5A
- Standard 120/600 Vac line three-phase power supply module. Two separate source power supply modules available. One module from 110–240 Vac and 110–250 Vdc; the other module 24–48 Vdc only

Model 4100 Input and Output

Model	Input	Output
4000	0	0
4100	1 digital (dry contact)	3 relays

Control Power Input

Description	Separate Source	Self Powered	DC Source
Input range, AC	110–240 Vac \pm 10%	110–600 Vac \pm 10%	N/A
Frequency range	45–66 Hz	45–66 Hz	N/A
Input range, DC	110–250 Vac \pm 10%	N/A	24–48 Vdc \pm 20%
Burden	10 VA	10 VA	10 VA

Displayed Values

Description	Displayed Through Eaton's PowerNet System	Local Display
AC amperes, phases A, B, C	\pm 0.3%	\pm 0.3% \pm 1 digit
AC voltage, phase A-B, B-C, C-A	\pm 0.3%	\pm 0.3% \pm 1 digit
Phase A-N, B-N, C-N	\pm 0.3%	\pm 0.3% \pm 1 digit
Watts	\pm 0.6%	\pm 0.6% \pm 1 digit
Vars	\pm 0.6%	\pm 0.6% \pm 1 digit
VA	\pm 0.6%	\pm 0.6% \pm 1 digit
Watt-hours	\pm 0.6%	\pm 0.6% \pm 1 digit
VAR-hours	\pm 0.6%	\pm 0.6% \pm 1 digit
VA-hours	\pm 0.6%	\pm 0.6% \pm 1 digit
Power factor	\pm 1%	\pm 1%
Frequency	\pm 0.1 Hz	\pm 0.1 Hz
% THD	Through 31st harmonic	Through 31st harmonic

Note

All accuracy is measured as a percentage of full scale.

Wiring Diagrams

Field Wiring Connections

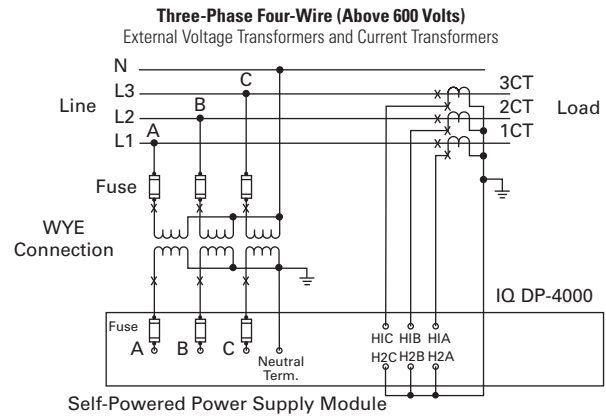
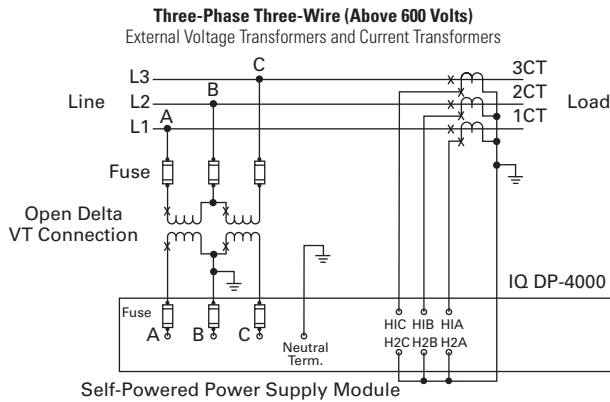
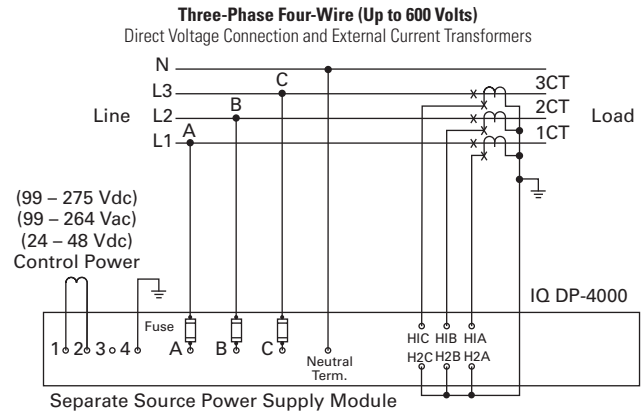
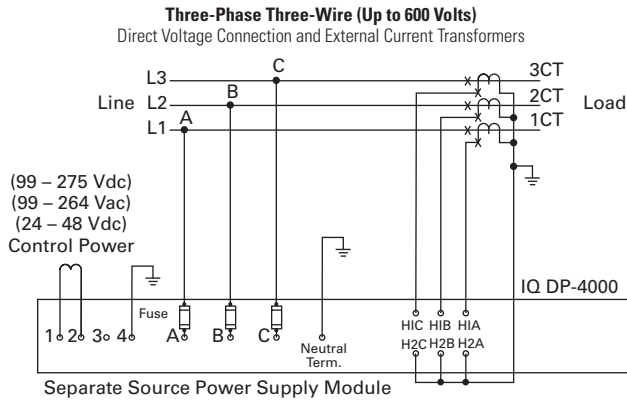

Dimensions

Approximate Dimensions in Inches (mm)

Drilling Pattern

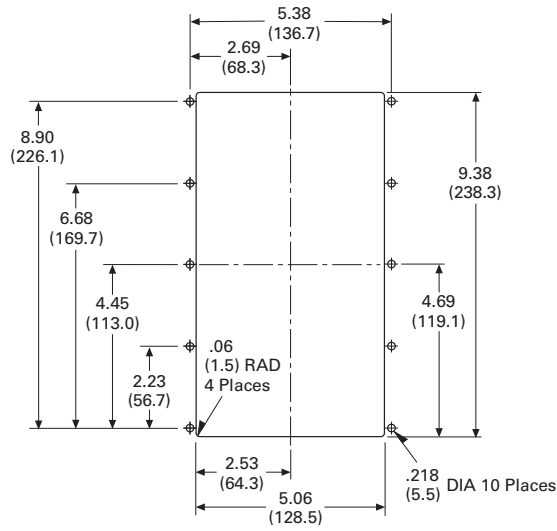

IQ DP-4000 Side View

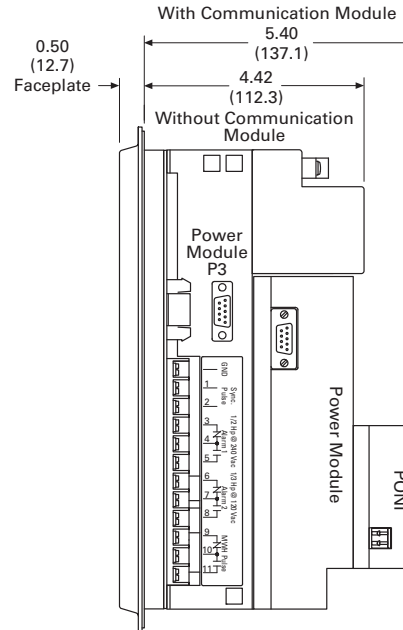

LED Display

Height	Width	Depth	Shipping Weight Lbs (kg)
PONI			
10.25 (260.4)	6.72 (170.7)	5.40 (137.2)	6.50 (3.0)
Without PONI			
9.02 (229.0)	7.80 (198.1)	4.42 (112.3)	12.5 (5.7)

IQ DP-4000 Auxiliary Power Supply

Width	Height	Depth
2.40 (61.0)	4.00 (101.6)	1.11 (28.2)

IQ 230 Digital Meter



Contents

<i>Description</i>	<i>Page</i>
Metering Products Family	V3-T9-21
Power Xpert Meter 4000/6000/8000 Series	V3-T9-30
Power Xpert Meter 2000 Series	V3-T9-49
IQ 250/260 Series Electronic Power Meters	V3-T9-60
IQ 130/140/150 Series Electronic Power Meters	V3-T9-66
IQ 150S/250S Self-Enclosed Electronic Meters	V3-T9-71
IQ 35M	V3-T9-76
IQ Analyzer 6400/6600 Series	V3-T9-79
IQ DP-4000 Series	V3-T9-87
IQ 230 Meters	
Features	V3-T9-94
Standards and Certifications	V3-T9-94
Product Selection	V3-T9-95
Technical Data and Specifications	V3-T9-96
Dimensions	V3-T9-99
Power Xpert Multi-Point Meter	V3-T9-100
IQ Energy Sentinel™	V3-T9-112
PM3 Monitoring and Metering Module	V3-T9-121
Current Transformers (CTs)	V3-T9-122
Clamp-On Current Transformers	V3-T9-131
IQ Flange	V3-T9-134
Panel Mounting Adapter Kit	V3-T9-135
Enclosed Meters	V3-T9-136

IQ 230 Meters

Product Description

The IQ 230 is a microprocessor-based metering and monitoring device. Its compact size and flexible mounting capabilities make it suitable for machine control panels such as panelboard and switchboard mains and feeders, low voltage metal-enclosed switchgear feeders and motor control centers. The IQ 230 series meter includes a base module and a display module. The IQ 230 base module has the flexibility to be directly mounted to the display or separately panel mounted. The display is integrally designed to fit a standard 1/4 DIN or a 100 mm ANSI cutout for new retrofit applications.

Application Description

The IQ 230 is ideal for individual load monitoring or provides an alternative to multiple ammeters, voltmeters, ammeter and voltmeter switches, wattmeters, varmeters, power factor meters, frequency meters, watt-hour and demand meters. ANSI C12 Class 10 revenue metering accuracy makes the IQ 230 ideal for sub-metering and sub-billing applications.

Features

The IQ 230 can be easily programmed from the display keypad, which features a 4 line x 20 character LED backlit LCD display. This menu driven device displays a variety of selectable electrical system values and may be programmed for password protection.

The IQ 230 series includes two variations all containing the same display module. The IQ 230 has built-in INCOM communications, KYZ pulse output, digital inputs, digital outputs and an analog input. The IQ 230M includes all the benefits of the IQ 230 but replaces INCOM communication with Modbus®

- Five different mounting options
- 1/4 DIN standard 3.60 inches (91.4 mm) x 3.60 inches (91.4 mm) cutout that meets global standards
- One meter style with multiple mounting choices—mount on panel, DIN rail or back of meter
- Autoranging power supply; one style for any voltage up to 600 Vac
- Direct connection up to 600 Vac. PTs are not required
- AC or DC powered
- Polarity sensing for errors such as improper wiring or forward and reverse power flow
- Membrane faceplate designed and tested to meet NEMA® 12 and IP52
- Nonvolatile storage of all set points and recorded peaks and minimums
- Built-in INCOM or Modbus communications capability
- Digital and analog I/O
- Utility seal provision

Monitored Values

- Phase currents
- Voltage, L-L, L-N
- System and per-phase power including wathours, varhours and VA-hours
- System demand including watt demand, VA demand and VAR demand
- Apparent and displacement power factor
- Frequency
- KYZ pulse output is available for use with a wathour pulse recorder or totalizer
- Recorded minimums and maximums of most values

Standards and Certifications

- UL and cUL listed
- UL file number E185559
- CSA certified (not ANSI revenue certified as a single-phase meter)
- CE mark for applications where European compliance is required
- IEC 1010-1 (1990) incl. amend. 1 and 2 (1995)
- EN61010-1 (1993)
- CSA C22.2 #1010.1 (1992)
- UL 3111



Product Selection

IQ 230 Meters

IQ 230 Meters



Description	Catalog Number
IQ 230 complete meter Includes base, display and 14-inch cable with INCOM Communications, KYZ output, digital inputs, digital outputs, analog input and utility seal provision	IQ230
IQ 230M complete meter Includes base, display and 14-inch cable with Modbus communications, KYZ output, digital inputs, digital outputs, analog input and utility seal provision	IQ230M
IQ 230 base module	IQ230TRAN
IQ 230M base module	IQ230MTRAN
IQ 200D IQ 210/220 display module	IQ200D
3-foot (0.9 m) category 5 cable	IQ23CABLE
6-foot (1.8 m) category 5 cable	IQ26CABLE
10-foot (3.0 m) category 5 cable	IQ210CABLE

Technical Data and Specifications**Compatible with the Following Systems:**

- Three-phase, three-wire
- Three-phase, four-wire
- Single-phase, two-wire
- Single-phase, three-wire

Current Input (Each Channel)

- Current range: 2 times
- Nominal full scale current: 5 amperes AC
- Overload withstand: 10 amperes AC continuous
150 amperes AC, 1 second
- Input impedance: 0.01 ohms
- Burden: 0.025 VA

Voltage Input (Each Channel)

- Voltage range (nominal): 90–600/347 Vac
- Nominal full scale voltage: 120–600/347 Vac
- Overload withstand: 660 Vac continuous,
800 Vac 1 second
- Input impedance: 2 megohm

CT (Primary) Settings

Select from 256 values ranging from 5–8000 amperes

- PT Primary 256 values with ratios up to 200 kV

Environmental Conditions

	Base	Display
Operating temperature	–20°C to 50°C	0°C to 50°C
Storage temperature	–30°C to 85°C	–20°C to 60°C
Operating humidity	0.0% to 95% noncondensing	—
Maximum relative humidity	80% up to 31°C	—

Frequency Range

50/60 Hz

Control Power Input

	Vac	Vdc
IQ 230	100–600 ±10%	48–250 ±10%
Frequency range	50–60 Hz ±10%	—
Burden	180 mA	700W

EMC

- Emissions
FCC Part 15 Class A
CISPR 11 (1990)/EN55011 (1991) Group 1 Class A
- Immunity
Electrostatic discharge
EN61000-4-2 (1995)/EN50082-2 (1995)
4 kV contact discharge
8 kV air discharge
Electrical fast transient
EN61000-4-4 (1995)/EN50082-2 (1995)
2 kV power lines
2 kV signal lines
Radiated immunity
EN61000-4-3 (1997)/EN50082-2 (1995)
10V/m
Conducted immunity
EN61000-4-6 (1996)/EN50082-2 (1995)
10V rms
Power frequency magnetic field
EN61000-4-8 (1995)
30 A/m

Metered Values and Accuracies at Full Scale

		Accuracy
AC ampere	Phase A Phase B Phase C	±0.5%
AC voltage	Phase A-B Phase B-C Phase C-A	±0.5%
Watts		±1.0%
VARs		±1.0%
VA		±1.0%
Watthours		±1.0%
VAR-hours		±1.0%
VA-hours		±1.0%
Power factor		±2.0%
Frequency		±0.1%

Communications

INCOM compatible 1200/9600 baud

- (IQ 230 only—does not require IPONI)

Modbus compatible 9600/19200 baud

- (IQ 230M only—does not require PONI)

Input/Output

KYZ solid-state relay output

- 96 mA at 240 Vac/300 Vdc
- Digital input 96 mA at 12–48 Vdc
- Digital output 96 mA at 125 Vac/176 Vdc
- Analog input 4–20 mA

Mounting the IQ 230 Base Module to the IQ 230 Display Module

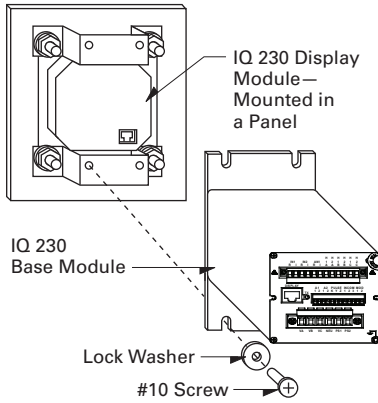

Display Mounting Options

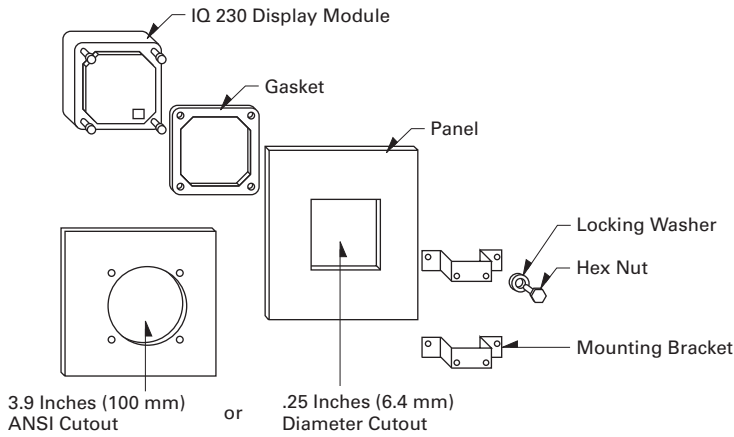

IQ 230 Base Connections

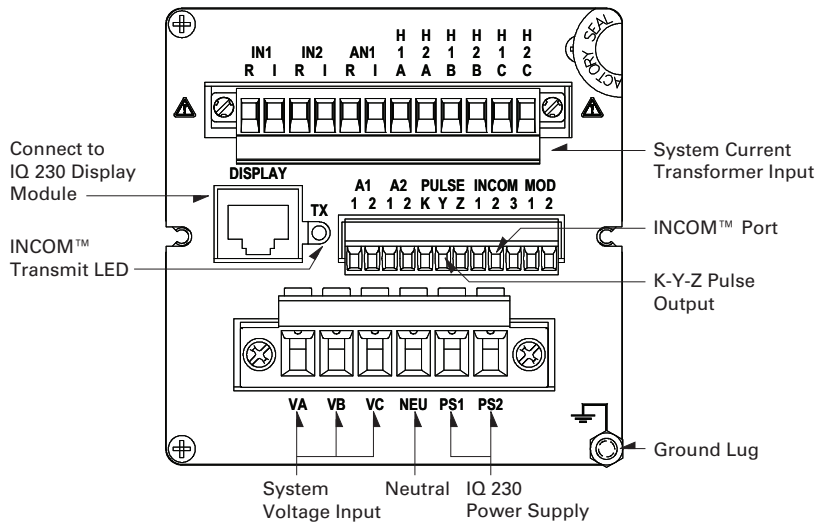

Wiring Diagrams

Typical Field Wiring Connections

Three-Phase Three-Wire (up to 600 Volts)

Proper CT polarity is critical to the proper operation of the meter

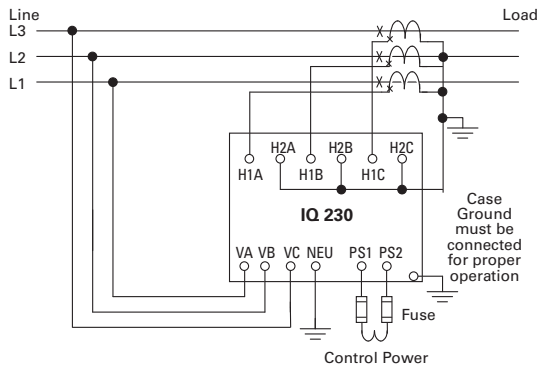

IQ 230
90–600 Vac
48–250 Vdc

Three-Phase Four-Wire (up to 600 Volts)

(Line Powered) Proper CT polarity is critical to the proper operation of the meter

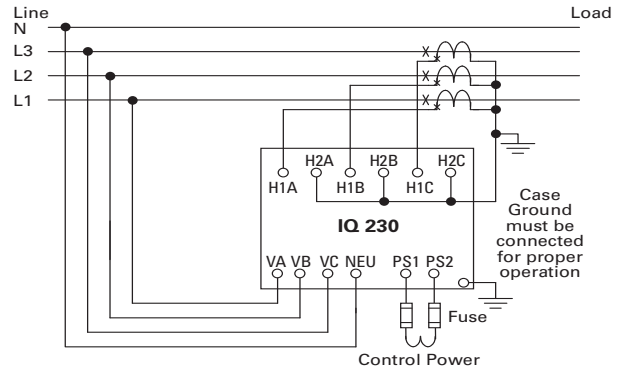

IQ 230
90–600 Vac
48–250 Vdc

Three-Phase Three-Wire (above 600 Volts)

Proper CT polarity is critical to the proper operation of the meter

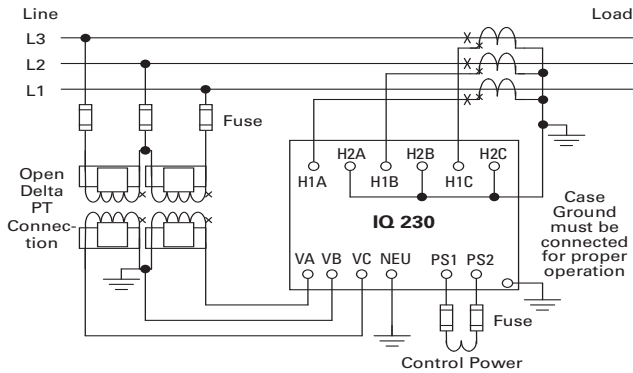

IQ 230
90–600 Vac
48–250 Vdc

Three-Phase Four-Wire (above 600 Volts)

Proper CT polarity is critical to the proper operation of the meter

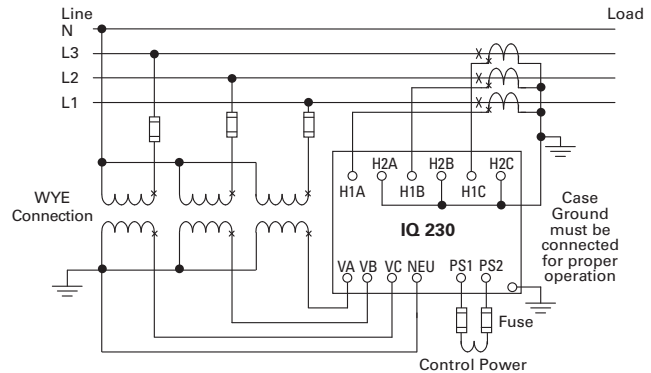

IQ 230
90–600 Vac
48–250 Vdc

Dimensions

Approximate Dimensions in Inches (mm)

IQ 230

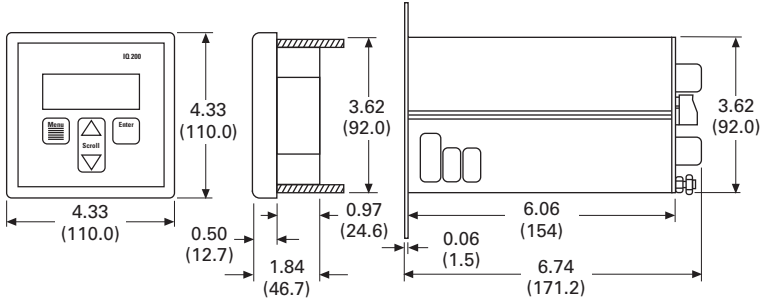

Mounting Hole Pattern for the IQ 230 Base Module

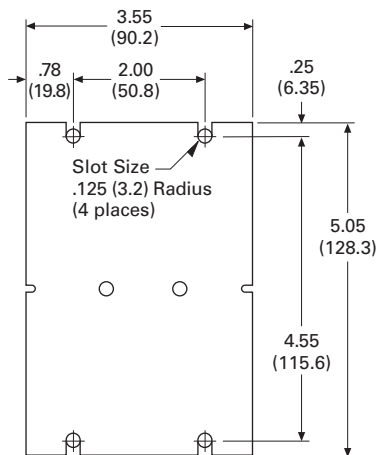

Power Xpert Multi-Point Meter

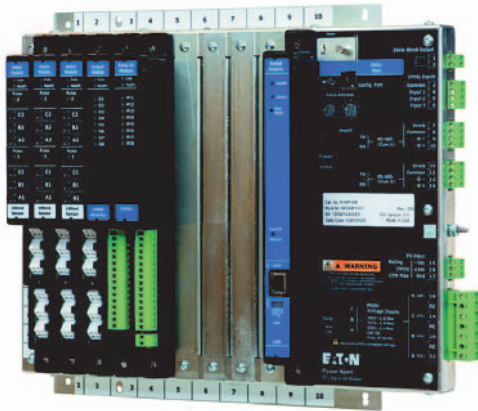

Power Xpert Multi-Point Meter

Product Overview

Eaton's Power Xpert™ Multi-Point Meter is an ANSI C12.20 revenue class Web-enabled electronic submetering device that can be mounted in panelboards switchboards or enclosures. When mounted in a panelboard or a switchboard, the Power Xpert Multi-Point Meter provides customers with an integrated power distribution and energy metering solution that saves space, reduces installation labor and lowers total cost.

The Eaton Power Xpert Multi-Point Meter (PXMP Meter) offers a highly modular approach to high-density metering applications in electrical power distribution systems. The PXMP Meter is compatible with most three-phase industrial, commercial and single-phase residential low voltage electrical power systems. The PXMP is equipped with two Modbus® RTU communication ports for local display and remote serial communications. The PXMP also has optional pulse input and digital output modules along with one standard digital output and three digital inputs. The PXMP Energy Portal Module is Web enabled, making it suitable for use with Ethernet networks and modems.

Contents

Description

<i>Description</i>	<i>Page</i>
Metering Products Family	V3-T9-21
Power Xpert Meter 4000/6000/8000 Series	V3-T9-30
Power Xpert Meter 2000 Series	V3-T9-49
IQ 250/260 Series Electronic Power Meters	V3-T9-60
IQ 130/140/150 Series Electronic Power Meters	V3-T9-66
IQ 150S/250S Self-Enclosed Electronic Meters	V3-T9-71
IQ 35M	V3-T9-76
IQ Analyzer 6400/6600 Series	V3-T9-79
IQ DP-4000 Series	V3-T9-87
IQ 230 Meters	V3-T9-93
Power Xpert Multi-Point Meter	
IQ Energy Sentinel™	V3-T9-112
PM3 Monitoring and Metering Module	V3-T9-121
Current Transformers (CTs)	V3-T9-122
Clamp-On Current Transformers	V3-T9-131
IQ Flange	V3-T9-134
Panel Mounting Adapter Kit	V3-T9-135
Enclosed Meters	V3-T9-136

Product Description

The Power Xpert Multi-Point Meter can measure up to any of the following number of circuits:

- Sixty single-phase, two-wire (single-pole)
- Thirty single-phase, three-wire (two-pole)
- Twenty three-phase, four-wire (three-pole)

The circuits listed above can be mixed provided that the total number of current sensors does not exceed 60. The meter provides current; voltage; power factor; demand and active, reactive, and real power (VA, VAR, kW); and active, reactive, and real energy (VA, VAR, kWh) measurements for each load. The unit also provides up to two years at 15-minute intervals or eight years at one-hour intervals of demand data logging storage in non-volatile memory for up to 60 submeters.

The Power Xpert Multi-Point Meter can be used with three different ratings of current sensors: 100 mA, 10 mA or 333 mV. Switchboard/panelboard applications will use the 100 mA current sensors, which are highly accurate, self-protecting in the event of an open circuit condition under load and are supplied with an integral plug-in connector. The PXMP automatically detects the rating of the current sensor that is connected.

The PXMP can also use 10 mA current sensors that were previously installed for IQMESII retrofit applications. Additionally, the PXMP can use 333 mV split core current sensors for retrofit applications where metering has not previously existed. The 10 mA and 333 mV current sensors are also self-protecting in the event of an open circuit condition under load.

Application Description

The Power Xpert Multi-Point Meter is ideally suited to handle submetering in low voltage power distribution equipment applications such as distribution boards in multi-tenant buildings, comprehensive main and feeder metering in commercial/industrial switchboards or medium voltage distribution equipment with the use of voltage and current transformers.

The Power Xpert Multi-Point Meter provides a cost-effective solution for residential or commercial metering installations. Typical installations include:

- High-rise buildings
- Government institutions
- K–12, universities and campuses
- Office buildings
- Medical facilities
- Apartment and condominium complexes
- Airports
- Shopping malls
- Industrial sites
- Mixed-use facilities

Features

- Monitors power and energy for up to 60 current sensors; space-saving modular design allows measurement from 1 to 60 circuits
- Built-in communication interfaces
- Monitors single-phase and three-phase loads from 120 to 600 Vac
- Monitors current, voltage, power factor, frequency, power and energy
- Stores extensive energy profile data for each metering point; can be used to identify coincidental peak demand contribution
- LEDs provide status of unit communication activity and verify sensor connections
- Meets rigid ANSI C12.20 accuracy specifications for revenue meters
- Three standard digital inputs and eight pulse inputs per optional module to monitor WAGES (water, air, gas, electric, or steam)
- One standard digital output and eight digital outputs per optional module for alarm indication
- Three types of meter modules to support 10 mA, 100 mA or 333 mV sensors

- Can be directly mounted in a UL Listed panelboard, switchboard or enclosure
- 256 MB of memory in meter base for up to two years of 15-minute interval data (eight years of one-hour interval data) for eight demand values up to 60 submeters

Communication Capabilities

With the Power Xpert Multi-Point Meter’s built-in communication capabilities, remote meter reading and monitoring functions can be integrated into both new and retrofit applications.

- Standard Modbus RTU
- Optional Modbus TCP / BACnet/IP / SNMP / HTTP / SMTP / NTP /SFTP communications

Software Compatibility

The Power Xpert Multi-Point Meter:

- Can be used as part of an electrical energy monitoring and cost allocation system
- Can be remotely monitored via onboard Web pages with Eaton’s optional Energy Portal Module
- Is compatible with third-party software platforms and interface devices

Configuration

- The Power Xpert Multi-Point Meter is fully configurable using Power Xpert Multi-Point configuration software that can be down-loaded free from the Eaton website at www.eaton.com/meters
- Each Power Xpert Multi-Point Meter module can be configured for up to six metering points in any combination of single-phase and three-phase metering points corresponding to the voltage wiring of the meter base
- Power Xpert Multi-Point configuration software simplifies system commissioning and startup; PXMP configuration software supports both online and offline configurations

Easy to Install

- UL Listed for mounting inside panelboards (e.g., PRL4), switchboards, and NEMA 12 enclosures
- Quick connect terminals for current sensors, Modbus communications, and bus voltages make wiring the unit quick and easy

Features

Description	Main/Aggregate	Channel Data	Tenant
Instrumentation			
Current, per phase	■ ①	■	—
Voltage, per phase (L-L, L-N)	■	■	—
Frequency	—	■	■
Minimum/maximum readings, V	Per phase	—	—
Minimum/maximum readings, W, VAR, VA	Total and per phase	—	—
Minimum/maximum readings, PF, F	Total	—	—
Power			
Real, reactive, and apparent power (W, VAR, VA)	Total and per phase	Total and per phase	Total
Power factor	—	Average	Average
Demand			
Block interval (fixed, sliding)	■	—	—
Real, reactive and apparent power demand	Total and per phase	—	—
Minimum/maximum readings, PF, W, VAR, VA	Total and per phase	Total	—
Energy			
Real, reactive and apparent energy (Wh, VARh, VAh)	Total	—	Total
Real, forward and reverse, and total (Wh)	■	—	■

Note
① Main only.

Standards and Certifications

Environmental

The PXMP Meter and current sensors must be housed in a NEMA or UL enclosure that keeps the internal environment within the PXMP's environmental specification ranges and provides suitable fire and mechanical protection in the end product installation.

- Temperature range: –20 to +70°C (–4 to +158°F)
- Storage temperature range: –40 to 85°C
- Humidity: 5–95% noncondensing environment
- Pollution degree: II
- Elevation: 0 to 9843 ft (0 to 3000m)
- Housing: IP20
- CE Mark
- EMC EN61326

Emissions Conducted and Radiated

- FCC part 15 Class B
- CISPR 11 Class B

Electromagnetic Immunity

Standard	Description	Level
EN61000-4-2	ESD	3
EN61000-4-3	RF radiated	3
EN61000-4-4	Electrical fast transient	3
EN61000-4-5	Surge	3 ①
EN61000-4-6	RF conducted	3
EN61000-4-11	Volt sag/swell/variation	—

Product Safety

- IEC/EN61010-1
- UL 61010-1 File E185559
- CNL evaluation to CAN/C22.2 No 1010.1.92

Accuracy

- ANSI C12.20—Accuracy Class 0.5% with either CSXXX or PXMP-CSXXX sensors
 - Measurement Canada Approval Pending



Product Selection

The Power Xpert Multi-Point Meter, current sensors, and other accessories can be ordered from Eaton distributors. Refer to the following catalog numbers when ordering.

Power Xpert Multi-Point Meter Products

Product Description	Catalog Number
Meter Bases and Meter Modules with ABCN Voltage Inputs	
PXMP meter base—three-phase with ABCN voltage inputs	PXMP-MB
PXMP meter module with six 100 mA inputs for use with PXMP current sensors	PXMP-MM100MA
PXMP meter module with six 10 mA inputs for use with IQMESII current sensors	PXMP-MM10MA
PXMP meter module with six 333 mV inputs for use with 333 mV current sensors	PXMP-MM333MV
Meter Bases and Meter Modules with ABN Voltage Inputs	
PXMP meter base—single-phase, three-wire with ABN voltage inputs	PXMP-MB-AB
PXMP meter module with six 100 mA inputs for use with PXMP current sensors	PXMP-MM100MA-AB
PXMP meter module with six 10 mA inputs for use with IQMESII current sensors	PXMP-MM10MA-AB
PXMP meter module with six 333 mV inputs for use with 333 mV current sensors	PXMP-MM333MV-AB
IO Modules	
PXMP meter pulse input module with eight inputs	PXMP-PIM
PXMP meter digital output module with eight outputs	PXMP-DOM
Communication Module	
PXMP meter energy portal module	PXMP-EPM
Current Sensor Kits	
KIT, PXMP CS125 sensor, quantity of 3	PXMP-CS125-3
KIT, PXMP CS250 sensor, quantity of 3	PXMP-CS250-3
KIT, PXMP CS400 sensor, quantity of 3	PXMP-CS400-3
Current Sensor Cable Kits	
KIT, PXMP sensor cable, 4 ft (1.2m), quantity of 3	PXMP-SC4-3
KIT, PXMP sensor cable, 6 ft (1.8m), quantity of 3	PXMP-SC6-3
KIT, PXMP sensor cable, 8 ft (2.4m), quantity of 3	PXMP-SC8-3
KIT, PXMP sensor cable, 12 ft (3.7m), quantity of 3	PXMP-SC12-3
Current Sensor Extension Cable Kits	
KIT, PXMP sensor extension cable, 8 ft (2.4m), quantity of 3	PXMP-SCE-8-3
KIT, PXMP sensor extension cable, 16 ft (4.9m), quantity of 3	PXMP-SCE-16-3
Interface Modules	
PXMP current sensor interface module for 333 mV, kit X 3	PXMP-IM333MV-3

Note

Total sensor lead length must not exceed 28 ft (8.5m).

The Pulse Input Module (PXMP-PIM) can be used to totalize pulse outputs from water meters, gas meters, steam meters or even old electrical meters with KZ pulse outputs. The PXMP-PIM can also be used for status monitoring in applications where status indication updates of 6 seconds over Modbus satisfies the application requirement.

Support products for the Power Xpert Multi-Point Meter include the HMI display, IMPCABLE and power supplies as described in the table below.

Power Xpert Multi-Point Meter Support Products

Product Description	Catalog Number
Communication cable, 1000 ft (305m), 600V insulation	IMPCABLE
PXMP meter display—6-inch color touchscreen (with cable)	PXMP-DISP-6
Power supply—single-phase 90–264 Vac, 24 Vdc at 2.5A	PSG60E
Power supply—three-phase 360–575 Vac, 24 Vdc at 2.5A	PSG60F
Power supply—three-phase 600 Vac, 24 Vdc	PSS55D

Meter Selection

Meter Module	Meter Base		Typical Applications		Enclosed PXMP 333MV Sensors, Split Core, CS-SP-X-XXXX-333MV, Ampere Ratings	Enclosed PXMP Interface Modules
	Three-Phase Application or Single-Phase with ABCN	Single-Phase Application with ABN	New Switchboards PXMP Current Sensors, Solid Core, PXMP-CSXXX, Ampere Ratings	Retrofit Existing IQMESII Sensors, Solid Core, CS-XXX, Ampere Ratings		
PXMP-MM100MA	PXMP-MB	—	125, 250, 400	—	—	—
PXMP-MM333MV	PXMP-MB	—	—	—	100, 200, 300, 400, 600, 800, 1000, 1200, 1600, 2000 ^①	PXMP-IM333MV
PXMP-MM10MA	PXMP-MB	—	—	5, 50, 70, 125, 200, 400	—	—
PXMP-MM100MA-AB	—	PXMP-MB-AB	125, 250, 400	—	—	—
PXMP-MM333MV-AB	—	PXMP-MB-AB	—	—	100, 200, 300, 400, 600, 800, 1000, 1200, 1600, 2000 ^①	PXMP-IM333MV
PXMP-MM10MA-AB	—	PXMP-MB-AB	—	5, 50, 70, 125, 200, 400	—	—

Note

^① For applications requiring more than 2000A current sensors, use a CS005 with 5A CT in conjunction with PXMP-MM10MA.

Technical data and Specifications

External Circuit Group Specifications

PXMP-MB (-AB) Meter base

Discrete Output

- Quantity 1—solid-state relay Form A NO Bidirectional FET
- Polarity of external source is not important
- Isolation circuit to ground 2 kV/1 min.
- Maximum external source voltage 28 Vdc
- Line-to-line TVS clamp across switching element at 32 Vdc
- Solid-state relay on resistance 35 ohms maximum
- Maximum load current 80 mA
- Minimum pulse width 20 milliseconds
- Fixed 25 milliseconds for pulse initiator function
- Maximum pulse rate 25 Hz
- Wiring to two-position removable terminal plug
 - 12–18 AWG (3.31–0.82 mm²), wire ferrules recommended
 - T1 (polarity not important)
 - T2 (polarity not important)

Discrete Inputs

- Quantity 3, common circuits inputs 1–3
- Group isolation 2 kV
 - No input-to-input circuit isolation
- All inputs per module share a common external 24V ($\pm 10\%$) supply
 - 24V externally sourced between common and inputs
 - Design to interface with external dry contact
 - Input impedance $\sim 2.2\text{K}$ ohms
 - Input current draw ~ 10 mA per input
- Minimum pulse width 10 milliseconds
- Maximum pulse rate 20 Hz
- Wiring to four-position removable terminal plug
 - 12–18 AWG (3.31–0.82 mm²), wire ferrules recommended
 - T3—Common (connect ext. 24 common here)
 - T4—Input 1 (dry contact to 24V hot)
 - T5—Input 2 (dry contact to 24V hot)
 - T6—Input 3 (dry contact to 24V hot)

COM1 and COM2 RS-485 Serial Ports

- No D+/D– biasing reliance on fail-safe driver and biasing at Master
- Baud rate configurable between 9600–115K baud (default)
- Use cable designed for RS-485 communications
 - Low L:L capacitance
 - Impedance of ~ 100 – 120 ohms
 - Shield—Mylar for high frequency; Braid for low frequency
 - Separate common and shield for best noise immunity
 - Maximum cable length is 4000 ft (1219.2m) with 32 nodes at 19.2K baud increased data rates will reduce maximum cable distance
 - 2000 ft (609.6m) with 32 total nodes at 115.2K baud
- Isolation 300V to ground due to TVS diode clamps
- Modbus RTU slave protocol, address defined by rotary switch
- Green Rx and Red Tx LEDs per channel
- Data + > Data—during idle marked, logic 1 state

- End of Line Termination resistance should match cable impedance (typ. 100–120 ohms)
- Four-position removable terminal plug 18–22 AWG (0.82–0.33 mm²) typical, wire ferrules recommended
 - COM1
 - T7—Shield
 - T8—RS-485 common
 - T9—Data –
 - T10—Data +
 - COM2
 - T11—Shield
 - T12—RS-485 common
 - T13—Data –
 - T14—Data +

PXMP-MB Power Supply Input

- 24 Vdc $\pm 20\%$
- 15W maximum load
- 1 kV isolation barrier internal to PXMP-MB
- Externally fuse circuit to protect wire
- Green power OK LED
- Three-position terminal block 16–12 AWG (1.31–3.31 mm²), wire ferrules recommended
 - T15—24 Vdc – (common)
 - T16—24 Vdc + (Hot)
 - T17—Shield (optional) capacitively referenced to chassis ground for enhanced EMC performance

Meter Voltage Inputs

- Overvoltage CAT III
- Maximum voltage rating
 - 480VL:G (corner grounded delta)
 - 347VL:N
 - 600VL:L
- Frequency rating 47–63 Hz
- Metering range (temporary transitions)
 - 30–700VL:N
 - 30–700VL:L
- Abuse withstand rating 1000V sustained
- High pot withstand rating 2500V/1min
- Input impedance 4M ohms
- Fuse inputs rated to protect wiring to mains. External fuses
 - must be installed between the meter voltage terminal and the mains disconnect switch to the main lines to protect the lines. 600V 1 A BUSS type KTK-R-1 Fast Acting or equivalent fuses
 - are recommended.
- Wiring to removable terminal plug 10–18 AWG (5.26–0.82 mm²), wire ferrules recommended
 - T18—N (VR)
 - T19—C (V3)
 - T20—B (V2)
 - T21—A (V1)

PXMP meter modules (PXMP-MMs)

Compatible with all PXMP Meter Base slots 1–10 LED indicators:

- Health and status green, blink to show activity
- Pulse energy output one red per group of three loads
- Load energy direction red/green pair per load

All variations support six load inputs.

Current sensor connection is one 2 x 2 connector per load.

Compatible with PXMP-SCXX sensor cables, total cable length to the sensor should not exceed 28 ft (8.5m).

Note that -AB suffix only affects what voltage channels the loads are paired with for metering purposes.

PXMP-MM10MA supports the CSXXX series of 10 mA maximum secondary output current transformers.

PXMP-MM100MA supports the PXMP-CSXXX series of 100 mA maximum secondary output current transformers.

PXMP-MM333MV supports 333 mV maximum secondary output current transformers with the use of the PXMP-IM333MV interface module.

PXMP digital output module (PXMP-DOM)

- Compatible with all PXMP-MB slots 1–10
- LED indicators
 - Health and status green, blink to show activity
 - Output On/Off status one green per output
 - Eight individual solid-state relay outputs
- Each circuit rated for 24 Vdc ($\pm 20\%$) with an 80 mA load maximum
- 24 Vdc is externally sourced
- Group isolation to ground 2 kV
- Each circuit has its own separate common, circuit-to-circuit isolation 120V
- 16-position removable terminal plug
- 12–18 AWG (3.31–0.82 mm²), wire ferrules recommended

PXMP pulse input modules (PXMP-PIMs)

- Compatible with all PXMP-MB slots 1–10
- LED indicators
 - Health and status green, blink to show activity
 - Input On/Off status one green per pulse input
- Eight pulse inputs to external dry contacts
- Maximum pulse rate is 20 Hz
- Minimum pulse width is 20 milliseconds
- External circuit groups rated for 24 Vdc ($\pm 20\%$)
 - All circuits share the same electrical common
- External supply connects to the module with a two-position removable terminal plug
- The supply is internally fanned out to all circuits
- Group isolation limited to 300V to ground due to TVS diode clamp
- Input impedance $\sim 2.2K$ causing a 10 mA load per input when energized
- External circuit groups connect with a 16-position removable terminal plug
 - Terminals support 12–18 AWG (3.31–0.82 mm²), wire ferrules recommended

PXMP energy portal module (PXMP-EPM)

- Only functionally compatible with PXMP-MB slot 10
- LED indicators
 - Top health and status green, blink to show activity
 - Com. reset button—reset to defaults
 - Local IP 192/10
 - RJ45 front-facing Ethernet configuration port LEDs
 - Link (Tx/Rx blink)
 - 10/100 speed
- LED four-stack for bottom LAN/WAN Ethernet port
 - Link (Tx/Rx blink)
 - 10/100 speed
 - DHCP/Fixed
 - TX active
- Config. Ethernet RJ45 Cat5 STP/UTP
 - 10Base-T/100Base-Tx
 - Auto crossover capability supported
 - Java Web browser interface
- Bottom facing LAN/WAN Ethernet port
 - RJ45 Cat5 STP/UTP 10Base-T/100Base-Tx
 - STP required for full electromagnetic immunity
 - Auto crossover capability supported
 - Supports Modbus TCP and Java Web browser interface
- Bottom-facing telephone modem interface
 - Modem type V92/56K baud
 - RJ11 field interface

Power Xpert Multi-Point Meter System—Hardware Specifications

Components	Field Circuit	Power Source	Rated Voltage	Rated Current	Circuit Impedance	Isolation	Note 1	Note 2
PXMP-MB PXMP-MB-AB	Digital output	External	24 ±20% ①	0.080A maximum	35 ohms maximum	2.0 kV	—	—
	Digital input	External	24 ±20% ①	0.01A	2.22K	2.0 kV	Opto drops supply by 2V	Group are electrically common
	COM1 RS-485	Internal	5V ①	—	50–60 ohms	300V	TVS diode clamped to PE	—
	COM2 RS-485	Internal	5V ①	—	50–60 ohms	300V	TVS diode clamped to PE	—
	Power supply input	External	24 ±20% ①	0.7A maximum	N/A	1.0 kV	Installation Class II input	15W maximum
	Voltage inputs A (V1)/ B (V2)/ C (V3)/ N (VR)	External mains	480V L:G ②	0.12 mA	4M ohms	N/A	Installation Class III	High pot 2500V/1 minimum
347V L:N ②			0.09 mA	4M ohms	N/A	Installation Class III	High pot 2500V/1 minimum	
600V L:L ②			0.09 mA	4M ohms	N/A	Installation Class III	High pot 2500V/1 minimum	
PXMP-MM100MA	CT secondary	External	N/A	100 mA	14.6 ohms	N/A	20% over-range	See sensor for primary isolation
PXMP-MM10MA	CT secondary	External	N/A	10 mA	67 ohms	N/A	20% over-range	See sensor for primary isolation
PXMP-MM333MV	CT secondary	External	0.333V ②	N/A	50,000 ohms	N/A	20% over-range	See sensor for primary isolation
PXMP-DOM	Digital output	External	24 ±20% ①	0.080A maximum	10 ohms maximum	2 kV group	120V isolation circuit-to-circuit	Isolation dependent on external source
PXMP-PIM	Pulse input	External	24 ±20% ①	0.01A	2.22K ohms	300V to ground	TVS diode clamped to PE; group isolated, all circuits common to 24V external source	Note: Opto creates 2.2V drop sourced by 2.2K ohms; isolation dependent on external source
PXMP-EPM	Ethernet 100 Bt	Internal	—	N/A	N/A	1 kV	—	—
	POT modem	Internal	—	N/A	N/A	—	—	—

Notes

① DC.

② AC RMS.

Wiring Diagrams

Wiring for PXMB-MB

Note: For all voltage connections—fuses should be sized in accordance with best practices to protect the instrumentation wire.

Four-Wire Wye Voltage Connection Inputs

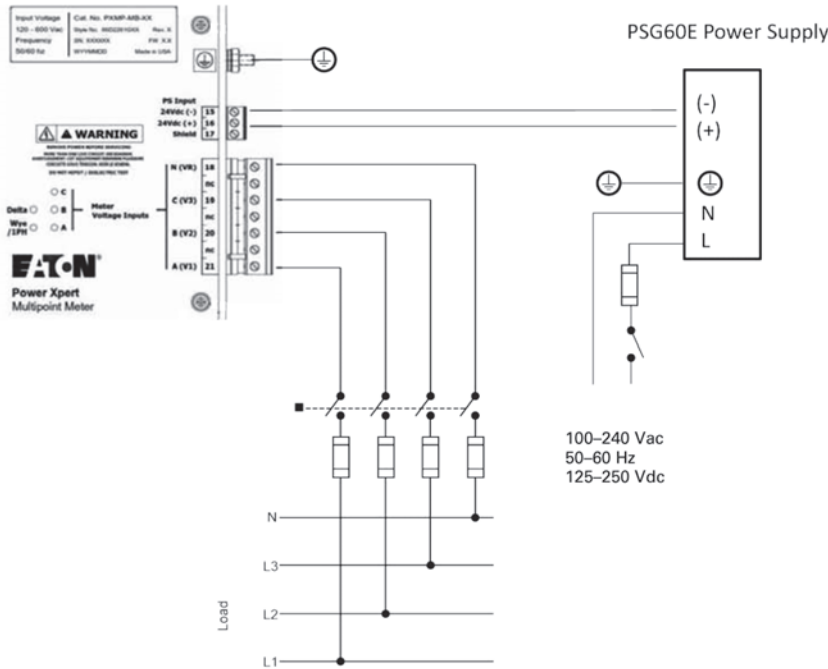

Three-Phase, Four-Wire Service Current Sensor Connections

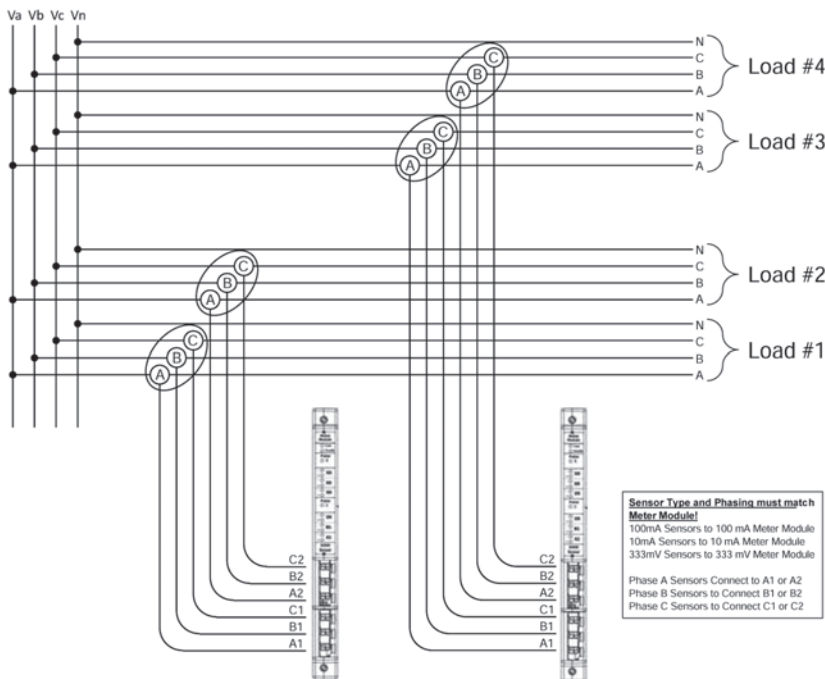

Three-Phase, Four-Wire Service (Ten Single-Phase, Single-Pole) Current Sensor Connections

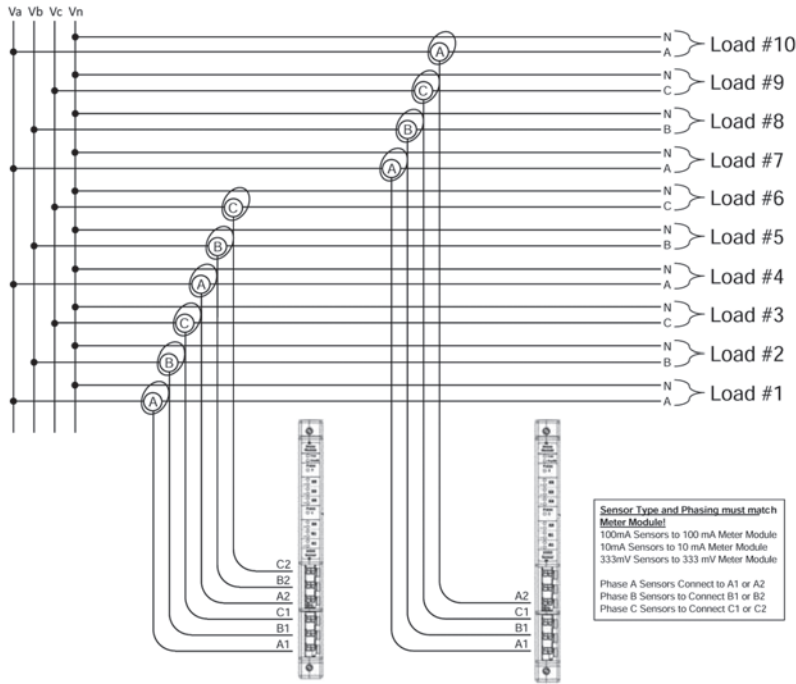

Network 120/208 Three-Wire Apartment Service Current Sensor Connections

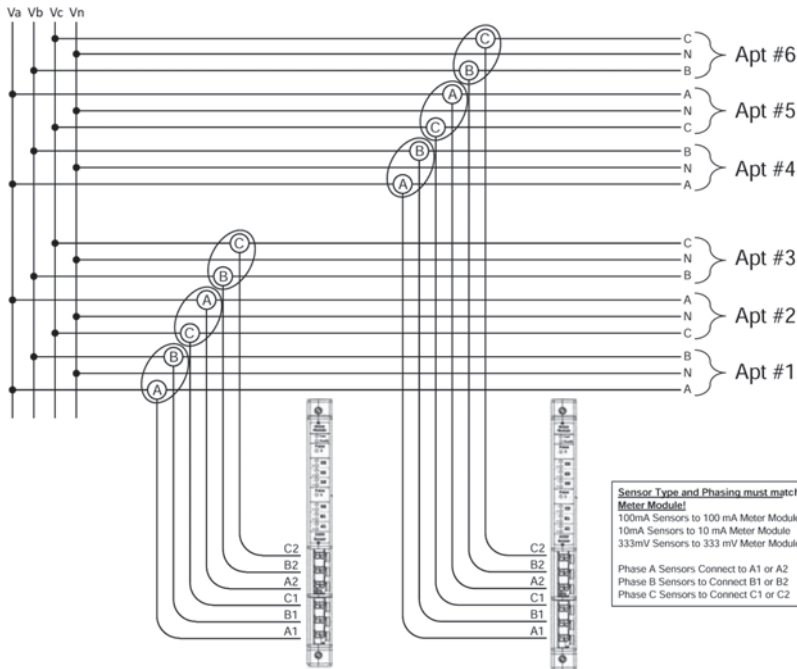

Wiring for PXMB-MB-AB

Note: For all voltage connections—fuses should be sized in accordance with best practices to protect the instrumentation wire.

Single-Phase, Three-Wire 120/240 Voltage Connection Inputs

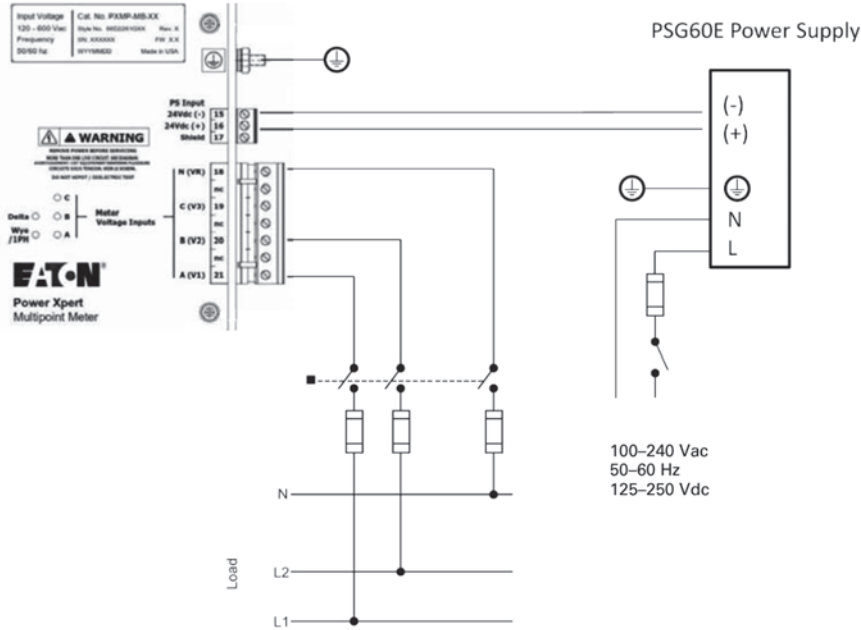

120/240 Single-Phase, Three-Wire Service Current Sensor Connections

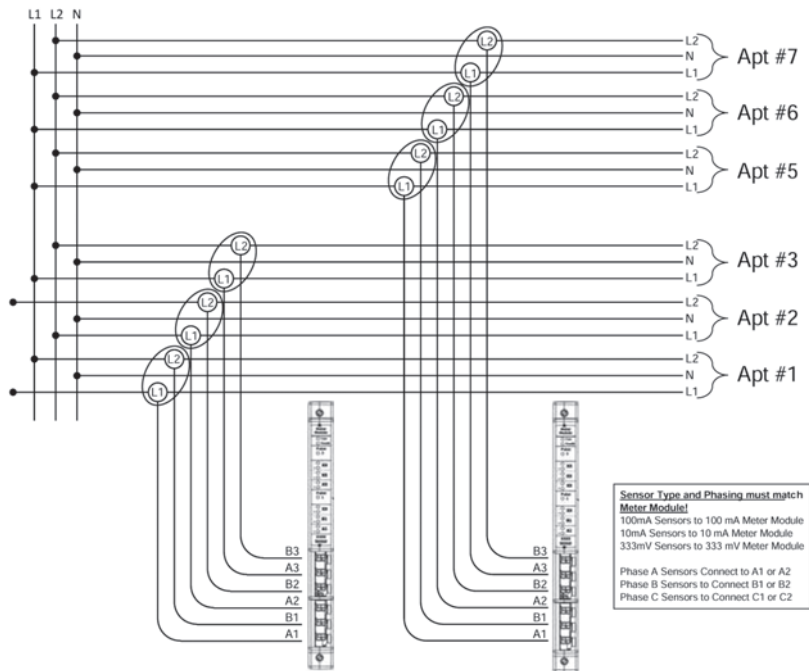

9.3

Metering Devices, Protective Relays, Software and Connectivity

Metering Devices

Dimensions

Approximate Dimensions in Inches (mm)

Single Unit—Front View

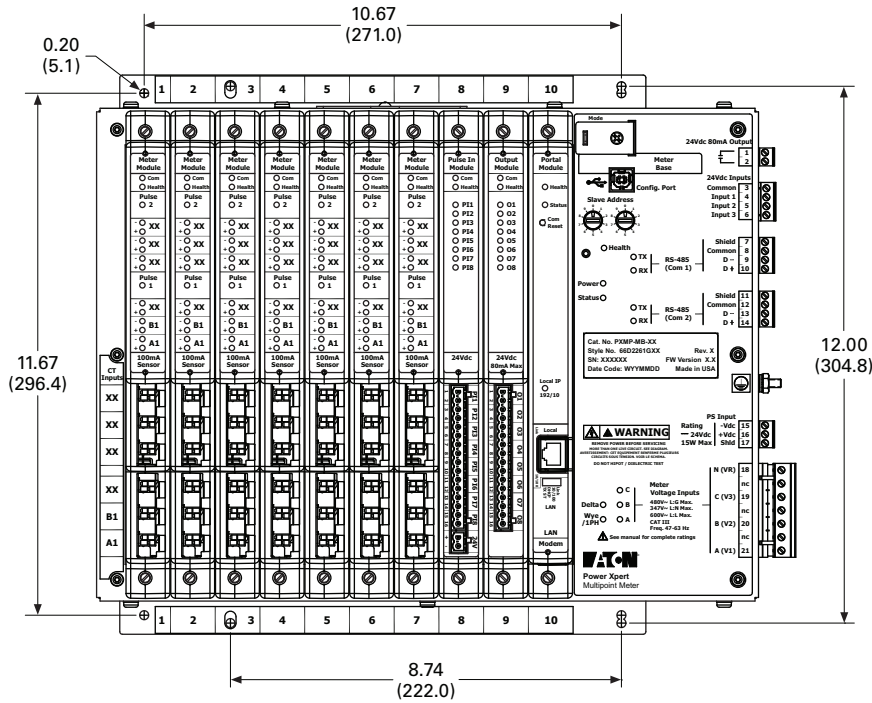

Single Unit—Side View

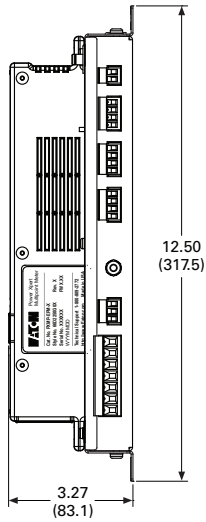

Current Sensor Dimensions

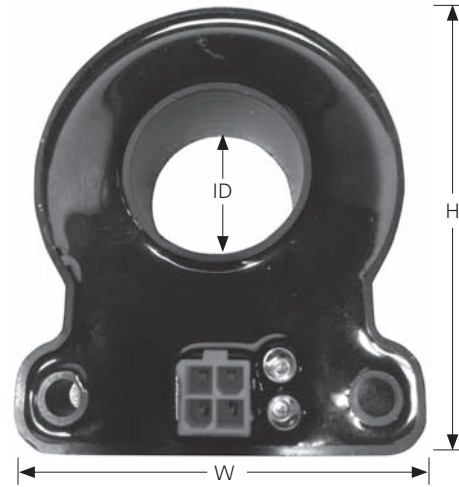

Single Unit—Top View

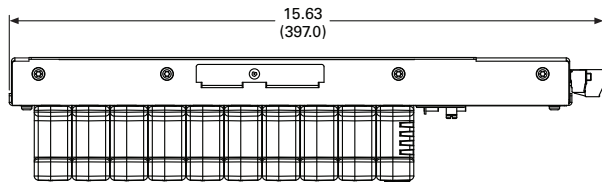

Current Sensor Dimensions

Sensor	H	W	D
PXMP-CS125	2.66 (67.6)	1.66 (42.1)	0.53 (13.5)
PXMP-CS250	2.96 (75.2)	2.42 (61.5)	1.12 (28.4)
PXMP-CS400	3.64 (92.5)	3.03 (73.2)	1.74 (44.2)

PXMP Color Touchscreen Display

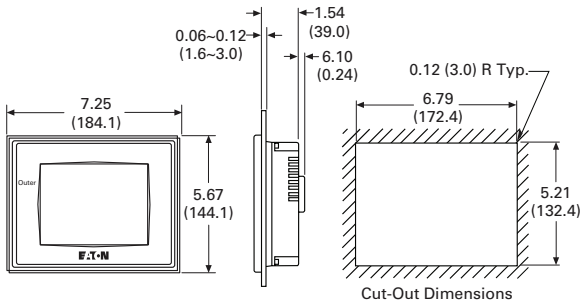

Open Interface Module (PXMP-IM333MV)

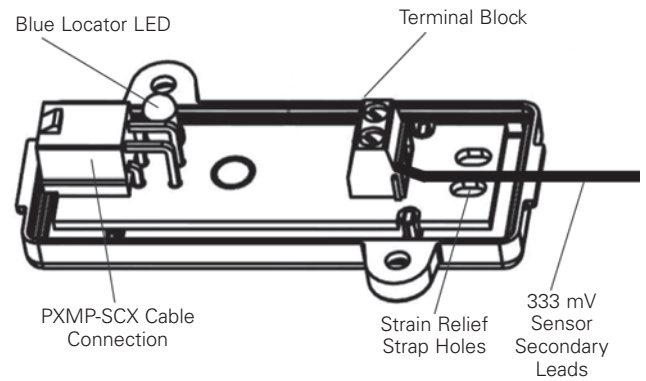

IQ Energy Sentinel

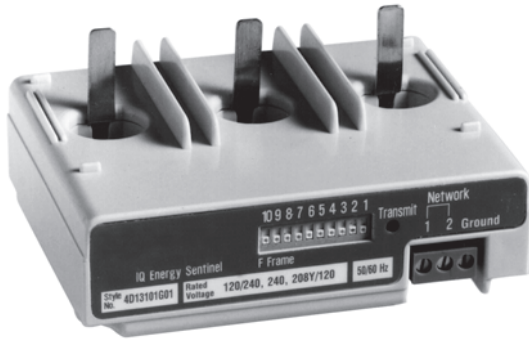

IQ Energy Sentinel™

Product Description

IQ Sentinels

IQ Sentinels are microprocessor-based submeters, designed to monitor power and energy. They represent an alternative to installing separate wattmeters, watthour meters and watt demand meters.

The Energy Sentinel monitors watts, watthour and watt demand.

Key advantages include unmatched savings in space, lower installation costs and the capability to communicate data readings in a variety of ways.

IQ Sentinels with built-in CTs and communications have the added benefit of greater overall system accuracy. Conventional metering often is less accurate since external CTs and separate transducers may each have inaccuracies of 1% or more.

Eaton's IQ Sentinels provide a unique cost-effective method to implement energy submetering at lower levels in the distribution system.

Contents

Description

	<i>Page</i>
Metering Products Family	V3-T9-21
Power Xpert Meter 4000/6000/8000 Series	V3-T9-30
Power Xpert Meter 2000 Series	V3-T9-49
IQ 250/260 Series Electronic Power Meters	V3-T9-60
IQ 130/140/150 Series Electronic Power Meters	V3-T9-66
IQ 150S/250S Self-Enclosed Electronic Meters	V3-T9-71
IQ 35M	V3-T9-76
IQ Analyzer 6400/6600 Series	V3-T9-79
IQ DP-4000 Series	V3-T9-87
IQ 230 Meters	V3-T9-93
Power Xpert Multi-Point Meter	V3-T9-100
IQ Energy Sentinel™	
Application Description	V3-T9-113
Features	V3-T9-114
Standards and Certifications	V3-T9-115
Product Selection	V3-T9-116
Technical Data and Specifications	V3-T9-116
Dimensions	V3-T9-119
PM3 Monitoring and Metering Module	V3-T9-121
Current Transformers (CTs)	V3-T9-122
Clamp-On Current Transformers	V3-T9-131
IQ Flange	V3-T9-134
Panel Mounting Adapter Kit	V3-T9-135
Enclosed Meters	V3-T9-136

The ability to monitor power distribution systems down to the machine or process level at an industrial facility has become essential to provide key benefits such as to verify the accuracy of the utility bill, identify and track energy usage to the loads that consume it, develop a facility energy profile to establish a baseline, allocate energy costs to create accountability, etc.

An optional door-mounted interface, the Subnetwork Master Local Display, is available to display the energy parameters monitored by the IQ Sentinels.

Submetering application examples for the IQ Sentinels include energy demand monitoring, product cost analysis, process machine tool efficiency and productivity improvement, and energy cost allocation or tenant billing for commercial, industrial, recreational and residential facilities.

Note: For customer billing applications, consult local utility for metering requirements.

Commercial applications include energy cost allocation within convention halls, office buildings, shopping malls, hospitals, warehouses and storage facilities.

Industrial applications include departmental billing and process/assembly line energy cost analysis. IQ Energy Sentinels may be substituted for watt transducers when monitoring machine tool and equipment performance within plants.

Recreational facilities include sports arenas, camping grounds, trailer parks and marinas.

The IQ Sentinel may be applied on three-phase (three- or four-wire), as well as single-phase (three-wire) systems.

IQ Sentinels may be applied on either 50 or 60 Hz systems.

Application Description

The IQ Energy Sentinel is available in three different package versions: breaker mounted, universal breaker with internal CTs, and universal breaker with external CTs.

Designed for mounting on Eaton's Series C® Circuit Breakers utilized in Eaton assemblies such as:

- Pow-R-Line four panelboards—feeder circuits
- Pow-R-Line C™ switchboards—feeder circuits
- Motor control centers and enclosed control with circuit breaker disconnects—starter or feeder circuits
- Enclosed Motor Control
- Enclosed circuit breakers
- Pow-R-Way III® bus plugs with circuit breaker disconnects

Breaker Mount Applications New Equipment



F-Frame Breaker with IQ Sentinel

Retrofitting

The space-saving design characteristics of the breaker mount IQ Energy Sentinels allow them to be added to existing Eaton circuit breakers at any time, often with no additional space or modifications required.

Or they may be installed when upgrading from older circuit breakers, often with no additional space or modifications required.

Universal Mount Applications



Universal Mount with Internal CTs

The universal mount IQ Energy Sentinel with internal CTs includes integral 400A CTs and may be applied on loads up to 400A. The universal mount IQ Energy Sentinels with internal CTs may be utilized wherever breaker mounting is not feasible or possible.

The universal mount IQ Energy Sentinel with provisions for external CTs may be applied on loads up to 4000A. They are usually utilized for monitoring loads larger than 400 amperes, on power cable sizes larger than 500 kcmil or on circuits containing more than one conductor per phase.

Features

IQ Energy Sentinel Features

Features

- Monitors (accuracy stated full scale)
 - Kilowatts ±1.0%
 - Kilowatts demand ±1.0%
 - Kilowatt Hour ±1.0%
- Built-in CTs version up to 400A or external CTs version up to 4000A
- Breaker, panel or DIN rail mounted
- Powered directly off the line
- Built-in communication capability
 - Address set by DIP switches
 - Communication at 9600 baud
 - Noise immune INCOM protocol
- Choice of operator interfaces
 - Subnetwork Master Local Display
 - Breaker Interface Module (BIM)
 - Power Management Energy Billing software
 - Power Management Software

Benefits

- One device replaces multiple meters and/or transducers
- Improved system accuracy
- Savings in product cost
- Savings in space
- Savings in installation cost
- No external power source is needed
- Permits remote monitoring and interconnection with programmable logic controllers and building management systems. For further information see section on Power Management Software Systems
- Designed to interface directly with Power Management Software Energy Billing software
- Flexibility—displays what is needed where it is needed
- Power Management Software

Eaton's Breaker Mount

Eaton's breaker mount IQ Energy Sentinel installs in less than 10 minutes on the load side of an Eaton F-Frame (150A), J-Frame (250A), or K-Frame (400A) circuit breaker.

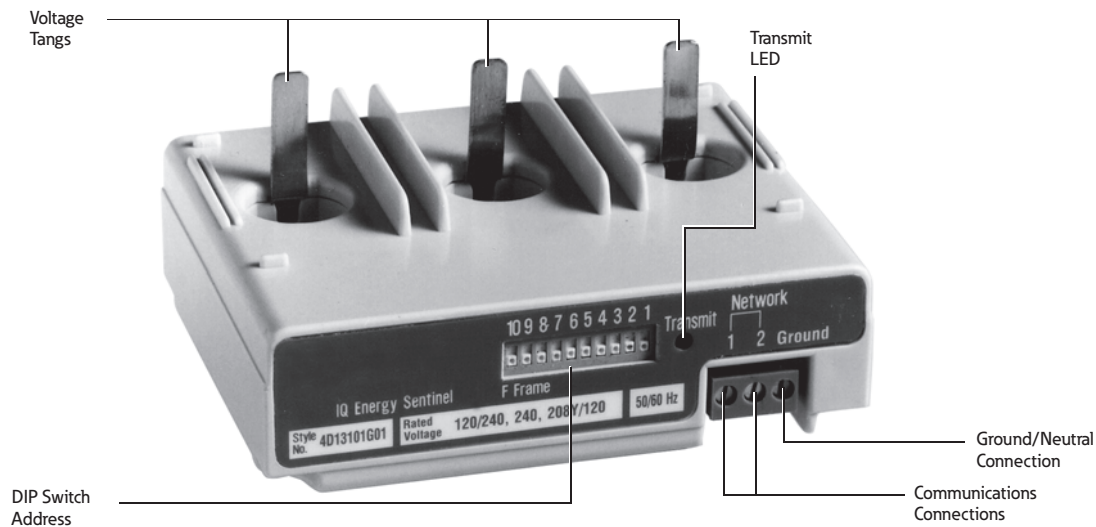

Energy Sentinel Features

Universal Mount with Internal CTs—(UI)

The Universal Mount IQ Energy Sentinel with internal CTs may be panel-mounted or DIN rail mounted on disconnects or other circuits up to 400 amperes. A pull-apart terminal block is provided on the device for connection of the system voltage reference wiring.

The location of the ground/neutral connection differs on Breaker Mount IQ Energy Sentinels from the location of the ground/neutral connection on Universal Mount IQ Sentinels. Incorrect wiring to the ground/neutral and communications connections may result in accuracy and communication errors.

Universal Mount for External CTs—(UE)

The Universal Mount IQ Energy Sentinel for external CTs may be panel-mounted or DIN rail mounted on circuits up to 4000 amperes.

A pull-apart terminal block is provided on the device for connection of the system voltage reference wiring as

well as another terminal block for connection to the user's existing 5-ampere secondary CTs that may range in standard ratios from 25:5 up to 4000:5.

Note: If the device will be disconnected without interruption of the monitored load, the use of a CT shorting block is advised.

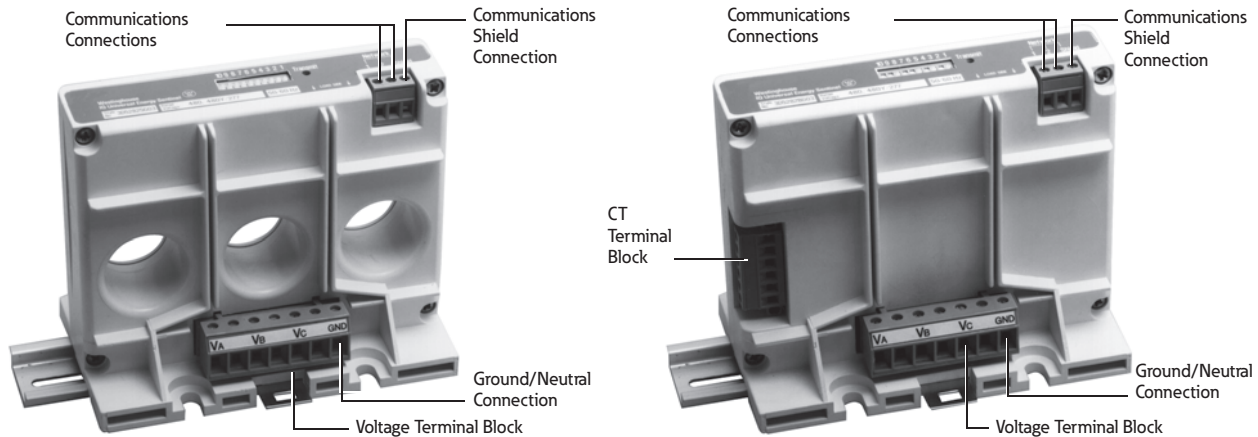

Energy Sentinel Features

Standards and Certifications

- UL listed, File E64983
- CSA approved, File LR106359-1



Product Selection

IQ Energy Sentinels

IQ Energy Sentinels



Description	Voltage Rating—Vac	Current Rating Maximum Amperes	Catalog Number
For F-Frame breakers	120/240, 240, 208Y/120	150	IQESF208
For F-Frame breakers	220/380, 230/400, 240/415	150	IQESF400
For F-Frame breakers	480, 480Y/277	150	IQESF480
For F-Frame breakers	600, 600Y/347	150	IQESF600
For J-Frame breakers	120/240, 240, 208Y/120	250	IQESJ208
For J-Frame breakers	220/380, 230/400, 240/415	250	IQESJ400
For J-Frame breakers	480, 480Y/277	250	IQESJ480
For J-Frame breakers	600, 600Y/347	250	IQESJ600
For K-Frame breakers	120/240, 240, 208Y/120	400	IQESK208
For K-Frame breakers	220/380, 230/400, 240/415	400	IQESK400
For K-Frame breakers	480, 480Y/277	400	IQESK480
For K-Frame breakers	600, 600Y/347	400	IQESK600
Universal with internal CTs	120/240, 240, 208Y/120	400	IQESUI208
Universal with internal CTs	220/380, 230/400, 240/415	400	IQESUI400
Universal with internal CTs	480, 480Y/277	400	IQESUI480
Universal with internal CTs	600, 600Y/347	400	IQESUI600
Universal for external CTs	120/240, 240, 208Y/120	4000	IQESUE208
Universal for external CTs	220/380, 230/400, 240/415	4000	IQESUE400
Universal for external CTs	480, 480Y/277	4000	IQESUE480
Universal for external CTs	600, 600Y/347	4000	IQESUE600

Technical Data and Specifications

Terminal, Cable and Wiring Guidelines

Sentinel	Eaton's Series C Terminal	Wire Size (Single Conductor)	Wire Types
F-Frame	G24B100G02, G17, G18, G19	#14–1/0, #4–4/0, #4–4/01, #14–1/0 AWG	THW, THHN, XHHW
J-Frame	T250KB, TA250KB	#4–350 kcmil	THW, THHN, XHHW
K-Frame	T350K, TA350KB	#250–500 kcmil	THW, THHN, XHHW
Universal Energy Sentinel with internal CTs	T350K, TA350KB	#250–500 kcmil	THW, THHN, XHHW
System Voltage Reference Wiring			
Energy Sentinel with internal or external CTs		#24–#10 AWG	
Current Transformer Wiring			
Universal with external CTs		#12 AWG (maximum)	
Ground Reference Wiring			
Energy Sentinel with internal or external CTs		#22–#12 AWG (minimum 600 volt rated)	
Communications Wiring			
Energy Sentinel with internal or external CTs		Eaton's IMPCABLE or Belden 9463 family	
F-Frame		Eaton's IMPCABLE or Belden 9463 family	
J-Frame		Eaton's IMPCABLE or Belden 9463 family	
K-Frame		Eaton's IMPCABLE or Belden 9463 family	

Energy Sentinel**Current Input**

Current range: 1% to 125% of current rating

Burden: 1 VA

Voltage Input

Voltage Range: $\pm 20\%$ of voltage rating

Frequency

50 or 60 Hz

Power Factor Range

All (-1 to +1)

Communications

Protocol: INCOM

Speed: 9600 baud

Compatibility: Power Management Software compatible

Environmental Conditions

Operating temperature: -25°C to 70°C ①
(-13°F to 158°F)

Storage temperature: -40°C to 85°C ①
(-40°F to 185°F)

Operating humidity: 5% to 95% relative humidity noncondensing

System Voltage Considerations (Application Note)

The Ground (GND) terminal of the IQ Energy Sentinel should be connected to the ground bus or other non-current carrying ground with 600V rated wire to ensure accuracy.

Note

① 40°C (standard) maximum for Series C circuit breakers.

Wiring Diagrams

Field Wiring—IQ Universal Energy Sentinel with Internal CTs

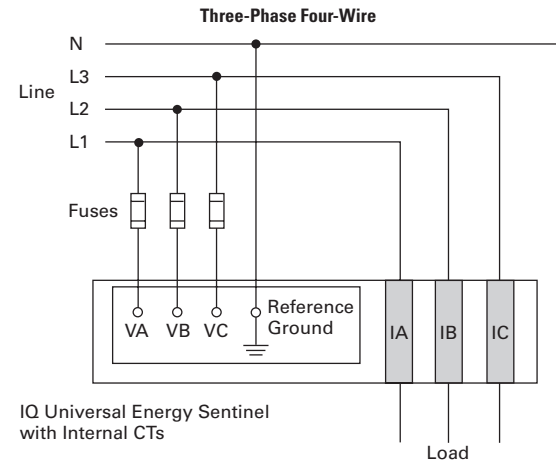
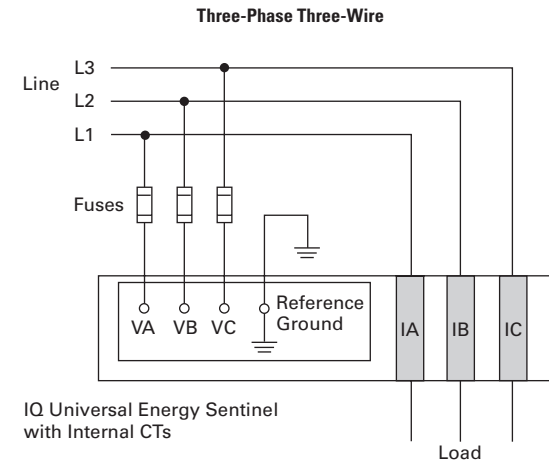
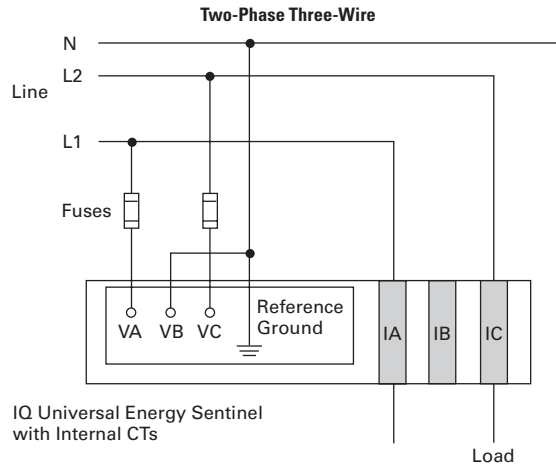
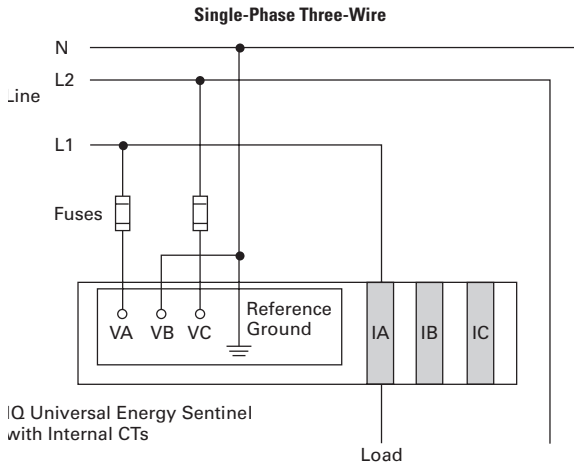

Acceptable System Configurations

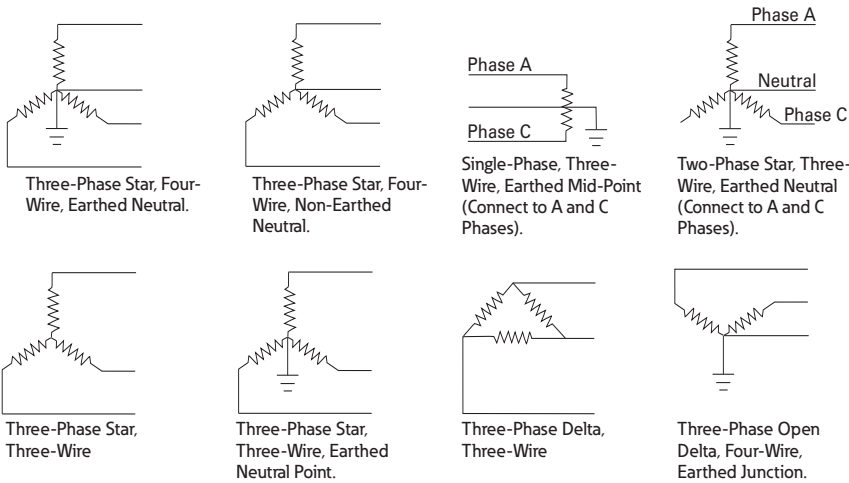

Note: Acceptable for Universal IQ Energy Sentinels only.

Dimensions

Approximate Dimensions in Inches (mm)

Energy Sentinel

Frame Type	D	W	H	CT Window Size ^①	Hole Clearance	Weight Lbs (kg)
F	3.20 (81.3)	4.12 (104.6)	1.30 (33.0)	0.59 (15.0)	—	0.65 (0.3)
J	4.04 (102.6)	4.12 (104.6)	1.28 (32.5)	0.77 (19.6)	—	0.69 (0.3)
K	4.04 (102.6)	5.31 (134.9)	1.25 (31.8)	0.96 (24.4)	—	0.87 (0.4)
UI	4.36 (110.7)	5.31 (134.9)	3.00 (76.2)	—	1.17 (29.7)	1.10 (0.5)
UE	4.36 (110.7)	5.31 (134.9)	3.00 (76.2)	—	—	1.10 (0.5)

Note

^① Acceptable for Universal IQ Energy Sentinels only.

IQ Sentinel

F-Frame Energy Sentinels

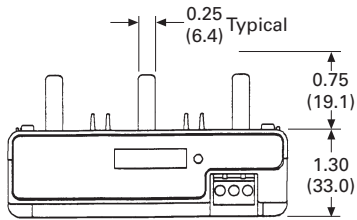

J-Frame Energy Sentinels

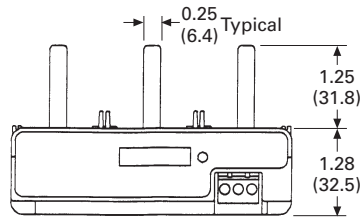

K-Frame Energy Sentinels

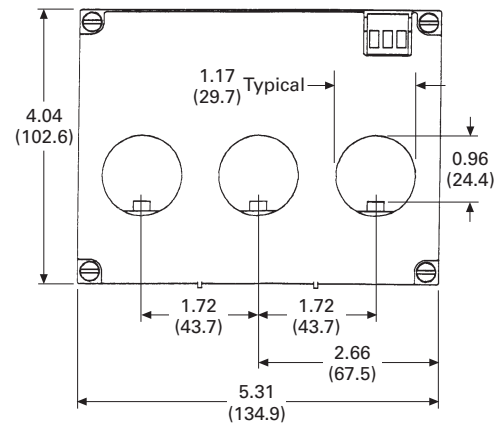
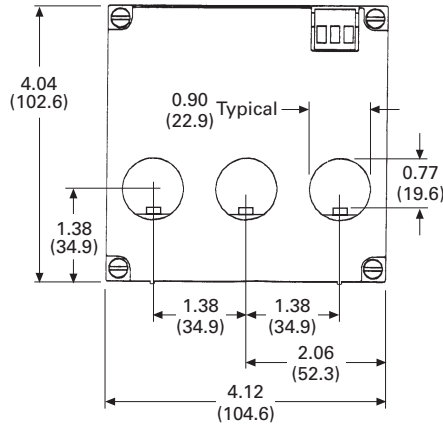
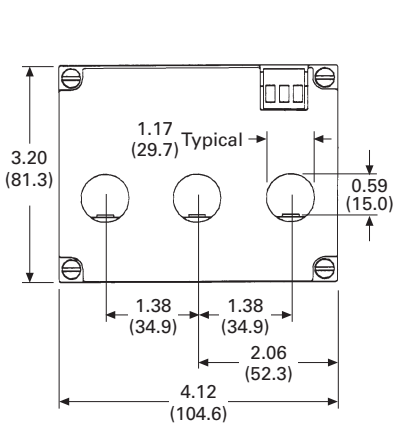
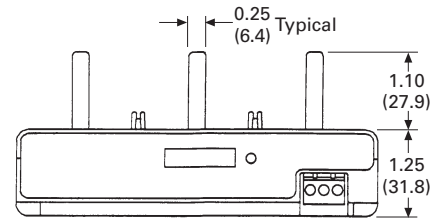

Universal with Internal CTs Energy Sentinels

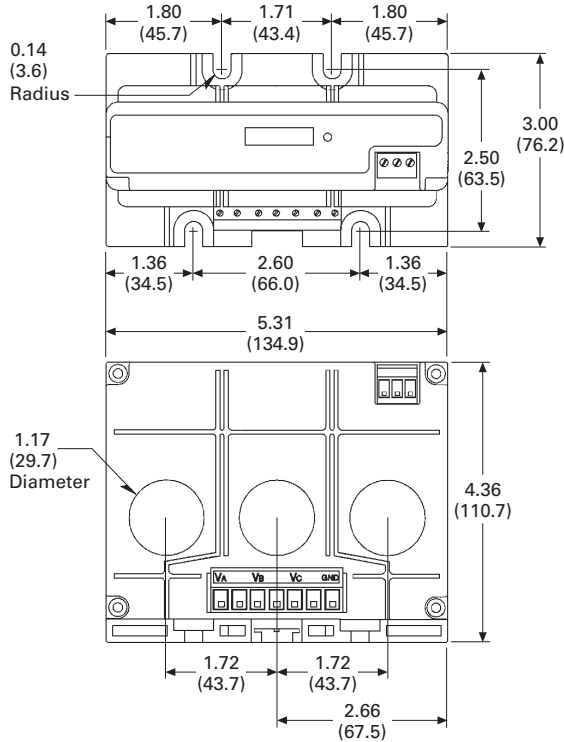

Universal with External CTs Energy Sentinels

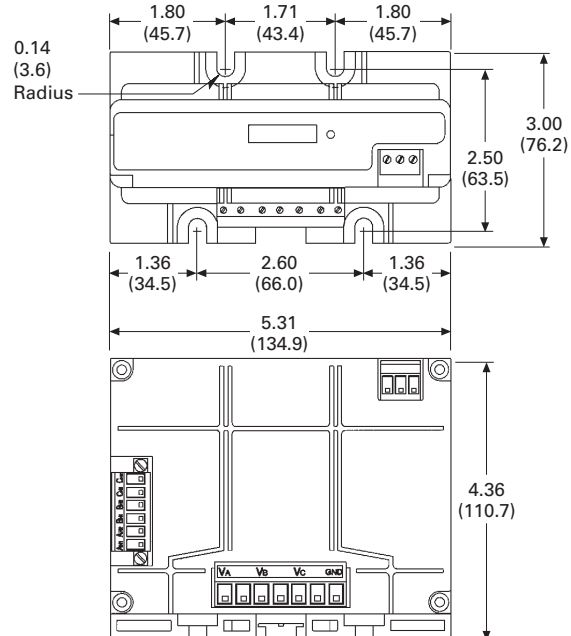

PM3 Modules



Power Monitoring and Metering with Modbus RTU

Contents

<i>Description</i>	<i>Page</i>
Metering Products Family	V3-T9-21
Power Xpert Meter 4000/6000/8000 Series	V3-T9-30
Power Xpert Meter 2000 Series	V3-T9-49
IQ 250/260 Series Electronic Power Meters	V3-T9-60
IQ 130/140/150 Series Electronic Power Meters	V3-T9-66
IQ 150S/250S Self-Enclosed Electronic Meters	V3-T9-71
IQ 35M	V3-T9-76
IQ Analyzer 6400/6600 Series	V3-T9-79
IQ DP-4000 Series	V3-T9-87
IQ 230 Meters	V3-T9-93
Power Xpert Multi-Point Meter	V3-T9-100
IQ Energy Sentinel™	V3-T9-112
PM3 Monitoring and Metering Module	
Current Transformers (CTs)	V3-T9-122
Clamp-On Current Transformers	V3-T9-131
IQ Flange	V3-T9-134
Panel Mounting Adapter Kit	V3-T9-135
Enclosed Meters	V3-T9-136

PM3 Monitoring and Metering Module
Product Description

For information on our PM3 product, please refer to **Volume 4, Tab 2.**

Current Transformers (CTs)

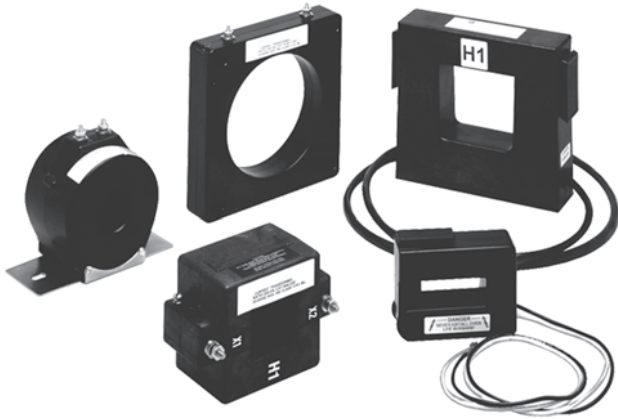

Contents

<i>Description</i>	<i>Page</i>
Metering Products Family	V3-T9-21
Power Xpert Meter 4000/6000/8000 Series	V3-T9-30
Power Xpert Meter 2000 Series	V3-T9-49
IQ 250/260 Series Electronic Power Meters	V3-T9-60
IQ 130/140/150 Series Electronic Power Meters	V3-T9-66
IQ 150S/250S Self-Enclosed Electronic Meters	V3-T9-71
IQ 35M	V3-T9-76
IQ Analyzer 6400/6600 Series	V3-T9-79
IQ DP-4000 Series	V3-T9-87
IQ 230 Meters	V3-T9-93
Power Xpert Multi-Point Meter	V3-T9-100
IQ Energy Sentinel™	V3-T9-112
PM3 Monitoring and Metering Module	V3-T9-121
Current Transformers (CTs)	
Product Selection	V3-T9-123
Dimensions	V3-T9-126
Clamp-On Current Transformers	V3-T9-131
IQ Flange	V3-T9-134
Panel Mounting Adapter Kit	V3-T9-135
Enclosed Meters	V3-T9-136

Current Transformers (CTs)

Product Description

Eaton’s low voltage current transformers are available in both solid core and split core designs. Engineered for electronic metering applications, all solid core designs and selected split core designs offer ANSI metering quality accuracy. The solid core designs also meet ANSI C57.13 relay accuracy requirements including over-ranging capabilities. The current transformer offering has a 5 ampere secondary at the rated primary current.

Split core CTs are specifically designed to be installed around primary conductors without disconnecting wires or breaking the circuit to be monitored. These current transformers are perfect solutions for energy management applications and are manufactured for installation ease.

Application Description

For new construction and retrofit applications where no current transformer exists, Eaton offers a complete selection of low voltage (up to 600V) current transformers. These current transformers can be used in commercial-grade applications, such as control panels and panelboards. Additionally, they can be used for most industrial metering and relaying applications in switchboards, switchgear and motor control centers. These CTs are intended for use with the Power Xpert Meter 2000/4000/6000/8000, IQ 250/260, IQ 130/140/150, IQ Analyzer 6400/6600, IQ DP-4000 and IQ 230 series.

Product Selection

Solid Core ANSI Metering Accuracy

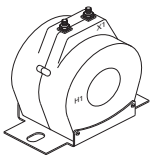
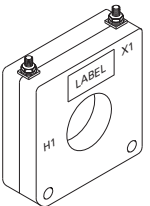
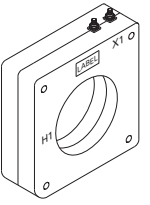
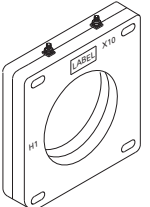
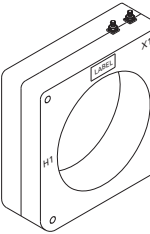
	Primary Current Rating	ANSI B0.1 Metering Class at 60 Hz (Accuracy in %)	Window Size in Inches (mm) Diameter	Catalog Number	Mounting Bracket Catalog Number
S060 	1.25 (31.8) Window				
	50	1.2	1.25 (31.8)	S060-500	①
	100	0.6	1.25 (31.8)	S060-101	①
	150	0.3	1.25 (31.8)	S060-151	①
	200	0.3	1.25 (31.8)	S060-201	①
S050 	1.56 (39.6) Window				
	300	0.3	1.56 (39.6)	S050-301	S050BRAC
	400	0.3	1.56 (39.6)	S050-401	S050BRAC
	500	0.3	1.56 (39.6)	S050-501	S050BRAC
	600	0.3	1.56 (39.6)	S050-601	S050BRAC
	750	0.3	1.56 (39.6)	S050-751	S050BRAC
	800	0.3	1.56 (39.6)	S050-801	S050BRAC
	1000	0.3	1.56 (39.6)	S050-102	S050BRAC
	1200	0.3	1.56 (39.6)	S050-122	S050BRAC
	S080 	3.25 (82.6) Window			
400		0.3	3.25 (82.6)	S080-401	S080BRAC
500		0.3	3.25 (82.6)	S080-501	S080BRAC
600		0.3	3.25 (82.6)	S080-601	S080BRAC
750		0.3	3.25 (82.6)	S080-751	S080BRAC
800		0.3	3.25 (82.6)	S080-801	S080BRAC
1000		0.3	3.25 (82.6)	S080-102	S080BRAC
1200		0.3	3.25 (82.6)	S080-122	S080BRAC
S090 	4.25 (108.0) Window				
	500	0.3	4.25 (108.0)	S090-501	S090BRAC
	600	0.3	4.25 (108.0)	S090-601	S090BRAC
	750	0.3	4.25 (108.0)	S090-751	S090BRAC
	800	0.3	4.25 (108.0)	S090-801	S090BRAC
	1000	0.3	4.25 (108.0)	S090-102	S090BRAC
	1200	0.3	4.25 (108.0)	S090-122	S090BRAC
	1500	0.3	4.25 (108.0)	S090-152	S090BRAC
	1600	0.3	4.25 (108.0)	S090-162	S090BRAC
	2000	0.3	4.25 (108.0)	S090-202	S090BRAC
	2500	0.3	4.25 (108.0)	S090-252	S090BRAC
	3000	0.3	4.25 (108.0)	S090-302	S090BRAC
	S025 	6.31 (160.3) Window			
600		0.3	6.31 (160.3)	S025-601	S025BRAC
750		0.3	6.31 (160.3)	S025-751	S025BRAC
800		0.3	6.31 (160.3)	S025-801	S025BRAC
1000		0.3	6.31 (160.3)	S025-102	S025BRAC
1200		0.3	6.31 (160.3)	S025-122	S025BRAC
1500		0.3	6.31 (160.3)	S025-152	S025BRAC
1600		0.3	6.31 (160.3)	S025-162	S025BRAC
2000		0.3	6.31 (160.3)	S025-202	S025BRAC
2500		0.3	6.31 (160.3)	S025-252	S025BRAC
3000		0.3	6.31 (160.3)	S025-302	S025BRAC
3500		0.3	6.31 (160.3)	S025-352	S025BRAC
4000		0.3	6.31 (160.3)	S025-402	S025BRAC

Note

① Contact Eaton for further information.

Split Core ANSI Metering Accuracy

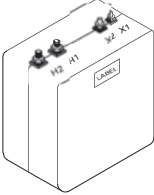
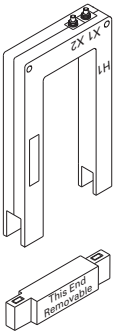
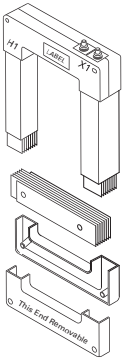
	Primary Current Rating	ANSI B0.1 Metering Class at 60 Hz (Accuracy in %)	Window Size in Inches (mm)	Catalog Number
W190 	Wound and Primary CTs			
	25	0.3	Wound	W190-025
	50	0.3	Primary	W190-050
M000 	2.00 x 5.50 (50.8 x 139.7)			
	400	2.4	2.00 x 5.50 (50.8 x 139.7)	M000-401
	500	2.4	2.00 x 5.50 (50.8 x 139.7)	M000-501
	600	2.4	2.00 x 5.50 (50.8 x 139.7)	M000-601
	800	1.2	2.00 x 5.50 (50.8 x 139.7)	M000-801
	1000	1.2	2.00 x 5.50 (50.8 x 139.7)	M000-102
	1200	0.6	2.00 x 5.50 (50.8 x 139.7)	M000-122
	1500	0.6	2.00 x 5.50 (50.8 x 139.7)	M000-152
	1600	0.6	2.00 x 5.50 (50.8 x 139.7)	M000-162
	2000	0.6	2.00 x 5.50 (50.8 x 139.7)	M000-202
	M050 	4.10 x 7.10 (104.1 x 180.3)		
600		4.8	4.10 x 7.10 (104.1 x 180.3)	M050-601
750		4.8	4.10 x 7.10 (104.1 x 180.3)	M050-751
800		2.4	4.10 x 7.10 (104.1 x 180.3)	M050-801
1000		2.4	4.10 x 7.10 (104.1 x 180.3)	M050-102
1200		1.2	4.10 x 7.10 (104.1 x 180.3)	M050-122
1500		1.2	4.10 x 7.10 (104.1 x 180.3)	M050-152
2000		0.6	4.10 x 7.10 (104.1 x 180.3)	M050-202
2500		0.6	4.10 x 7.10 (104.1 x 180.3)	M050-252
3000		0.6	4.10 x 7.10 (104.1 x 180.3)	M050-302
3500	0.6	4.10 x 7.10 (104.1 x 180.3)	M050-352	
4000	0.3	4.10 x 7.10 (104.1 x 180.3)	M050-402	

Split Core Current Transformers

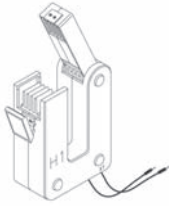
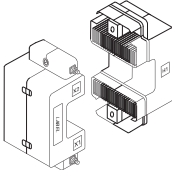
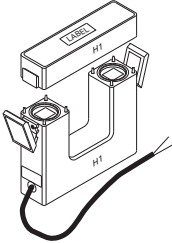
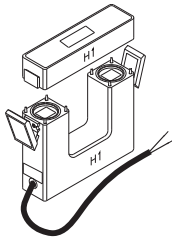
	Primary Current Rating	Accuracy at 60 Hz (in %)	Window Size in Inches (mm)	Catalog Number
M030 	0.80 x 1.95 (20.3 x 49.5)			
	100	5.0	0.80 x 1.95 (20.3 x 49.5)	M030-101
	150	5.0	0.80 x 1.95 (20.3 x 49.5)	M030-151
	200	4.0	0.80 x 1.95 (20.3 x 49.5)	M030-201
	300	2.0	0.80 x 1.95 (20.3 x 49.5)	M030-301
	400	2.0	0.80 x 1.95 (20.3 x 49.5)	M030-401
M040 	1.42 x 1.53 (36.1 x 38.9)			
	100	5.0	1.42 x 1.53 (36.1 x 38.9)	M040-101
	150	4.0	1.42 x 1.53 (36.1 x 38.9)	M040-151
	200	1.5	1.42 x 1.53 (36.1 x 38.9)	M040-201
	300	1.5	1.42 x 1.53 (36.1 x 38.9)	M040-301
	400	1.5	1.42 x 1.53 (36.1 x 38.9)	M040-401
M060 	2.60 x 2.75 (66.0 x 69.9)			
	200	1.0	2.60 x 2.75 (66.0 x 69.9)	M060-201
	300	1.0	2.60 x 2.75 (66.0 x 69.9)	M060-301
	400	1.0	2.60 x 2.75 (66.0 x 69.9)	M060-401
	500	1.0	2.60 x 2.75 (66.0 x 69.9)	M060-501
	600	1.0	2.60 x 2.75 (66.0 x 69.9)	M060-601
	750	1.0	2.60 x 2.75 (66.0 x 69.9)	M060-751
	800	1.0	2.60 x 2.75 (66.0 x 69.9)	M060-801
	1000	1.0	2.60 x 2.75 (66.0 x 69.9)	M060-102
	1200	1.0	2.60 x 2.75 (66.0 x 69.9)	M060-122
	M080 	2.60 x 6.25 (66.0 x 158.8)		
500		1.0	2.60 x 6.25 (66.0 x 158.8)	M080-501
600		1.0	2.60 x 6.25 (66.0 x 158.8)	M080-601
800		1.0	2.60 x 6.25 (66.0 x 158.8)	M080-801
1000		1.0	2.60 x 6.25 (66.0 x 158.8)	M080-102
1200		1.0	2.60 x 6.25 (66.0 x 158.8)	M080-122
1500		1.0	2.60 x 6.25 (66.0 x 158.8)	M080-152
1600		1.0	2.60 x 6.25 (66.0 x 158.8)	M080-162
2000		1.0	2.60 x 6.25 (66.0 x 158.8)	M080-202
2500		1.0	2.60 x 6.25 (66.0 x 158.8)	M080-252
3000		1.0	2.60 x 6.25 (66.0 x 158.8)	M080-302

9.3

Metering Devices, Protective Relays, Software and Connectivity

Metering Devices

Dimensions

Approximate dimensions in inches (mm)

S050

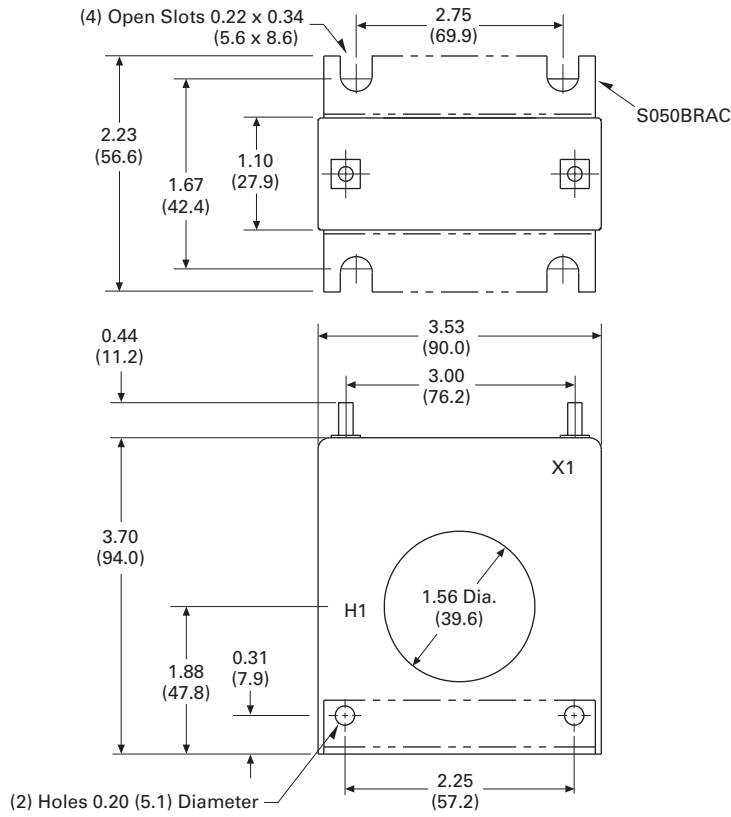
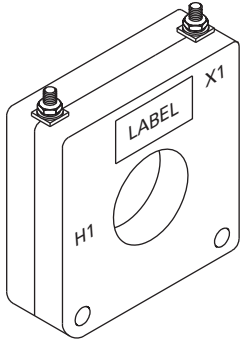

S060

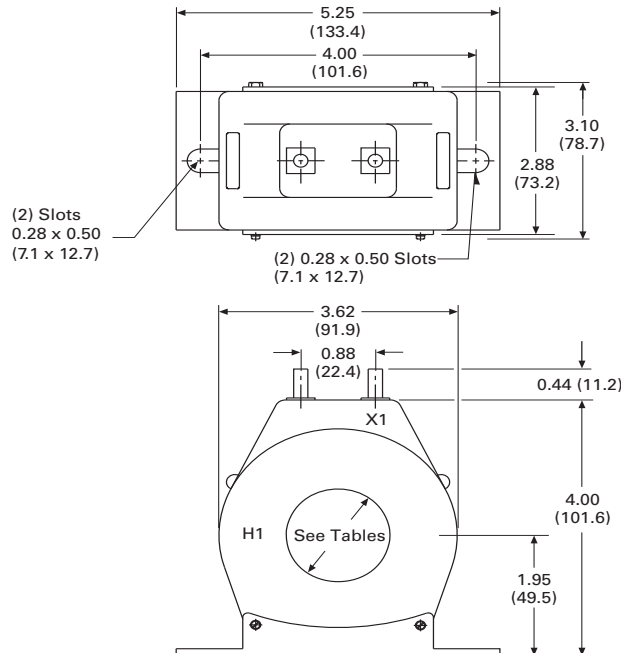
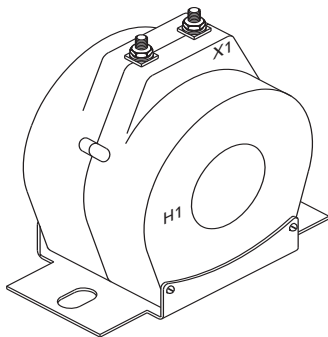

Approximate dimensions in inches (mm)

S080

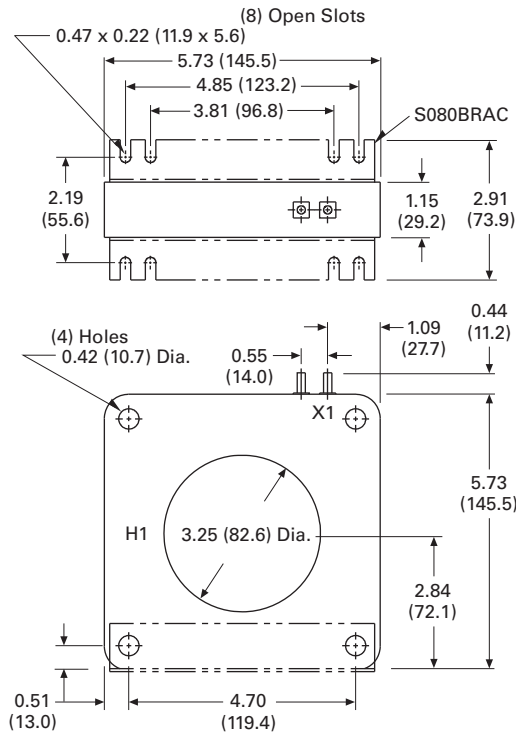
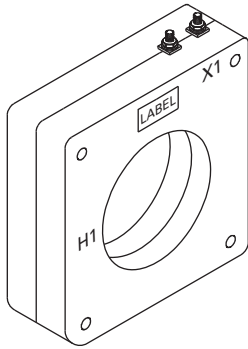

S090

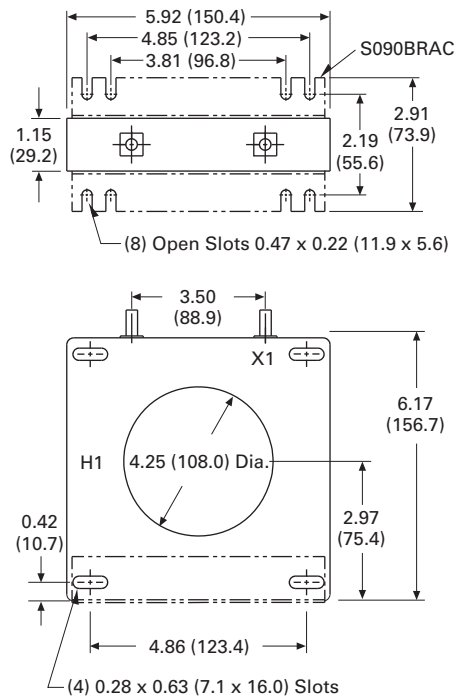
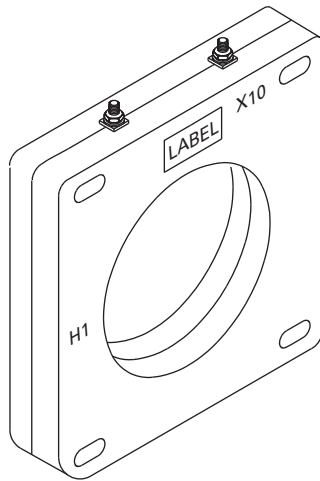

9.3

Metering Devices, Protective Relays, Software and Connectivity

Metering Devices

Approximate dimensions in inches (mm)

S025

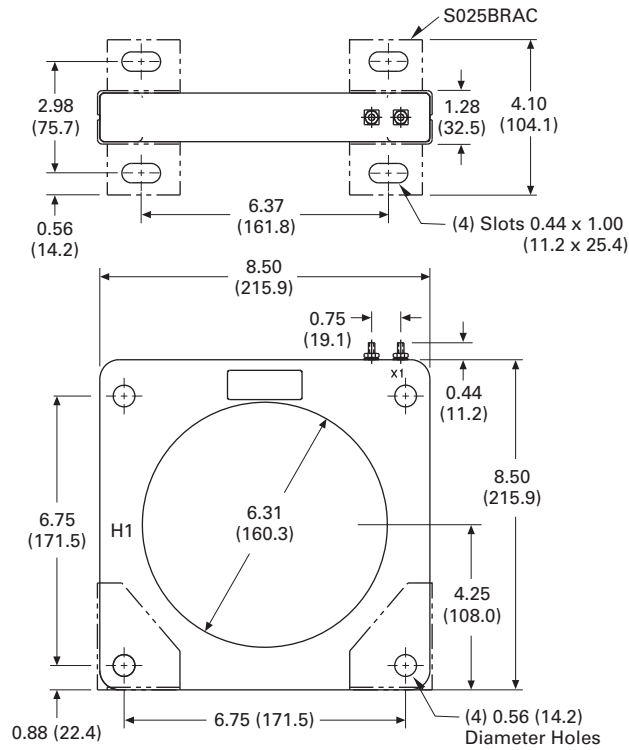
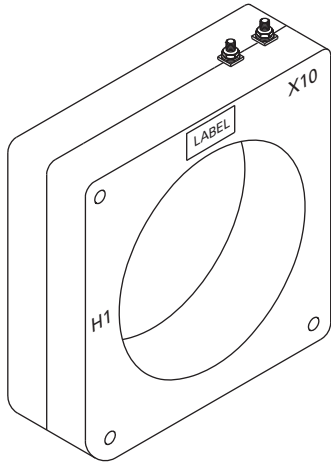

W190

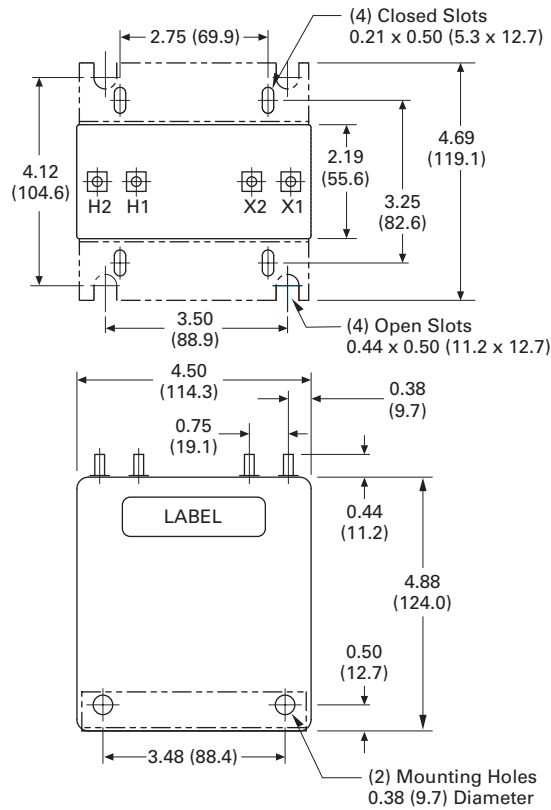
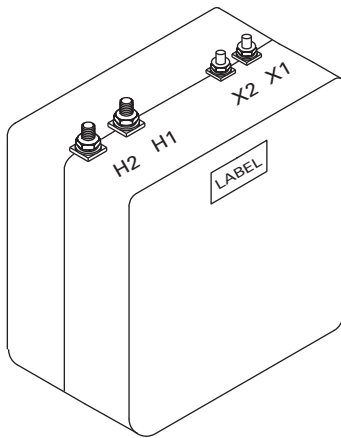

Approximate dimensions in inches (mm)

M000

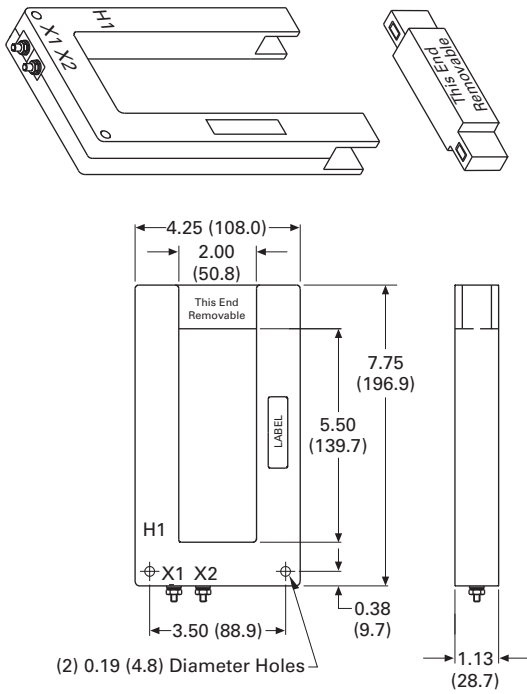

M050

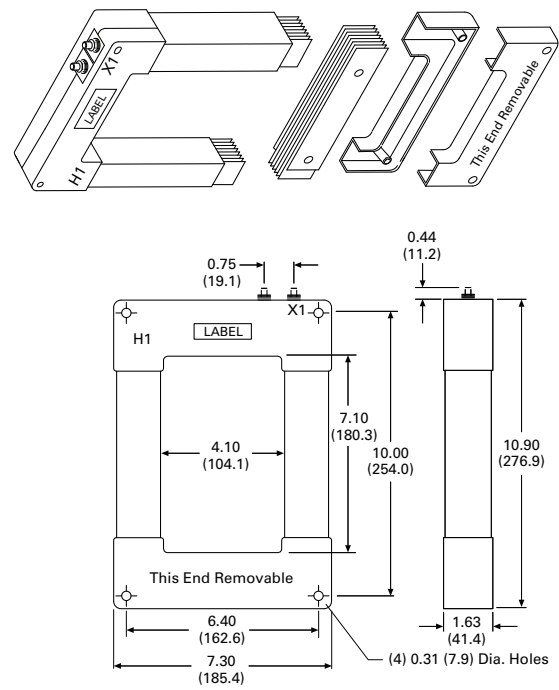

M030

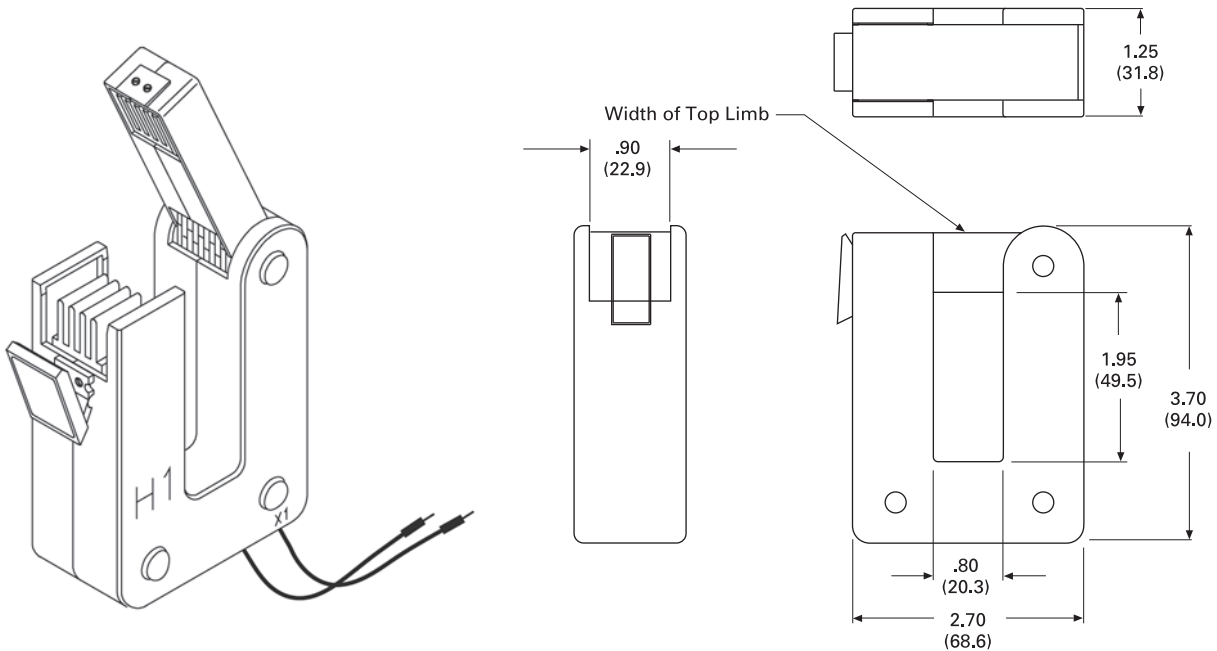

9.3

Metering Devices, Protective Relays, Software and Connectivity

Metering Devices

Approximate dimensions in inches (mm)

M040

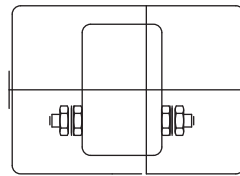
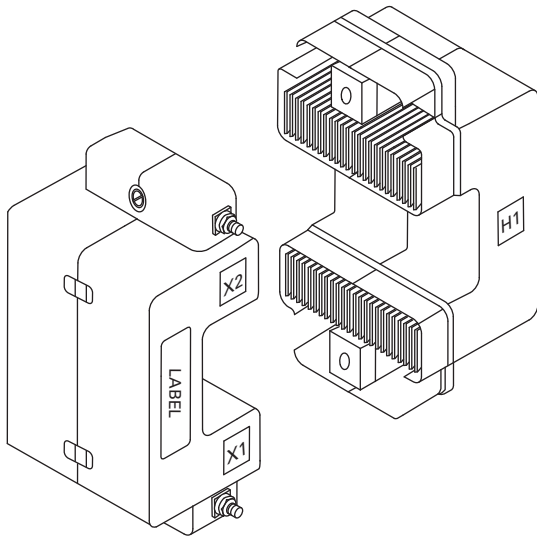

Terminal Arrangement for Ratios 250:5 through 400:5

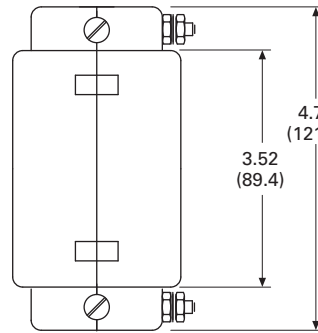

Terminal Arrangement for Ratios 100:5 through 200:5

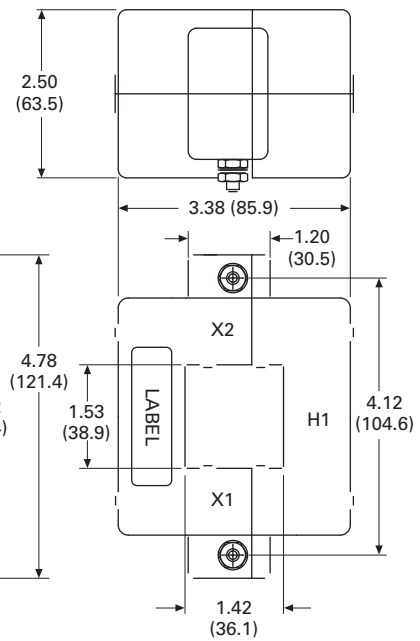

9

M060

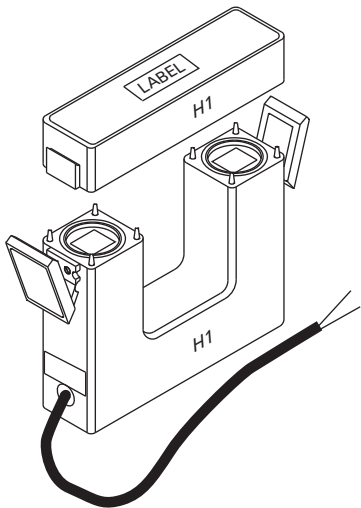

M080

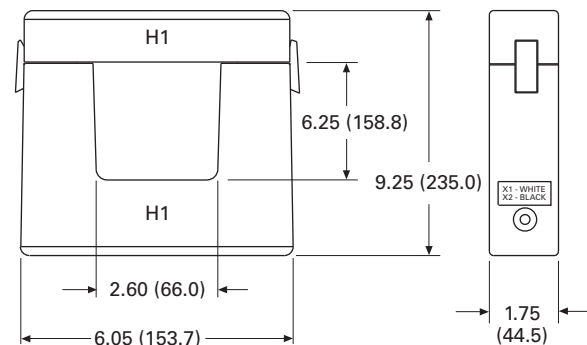
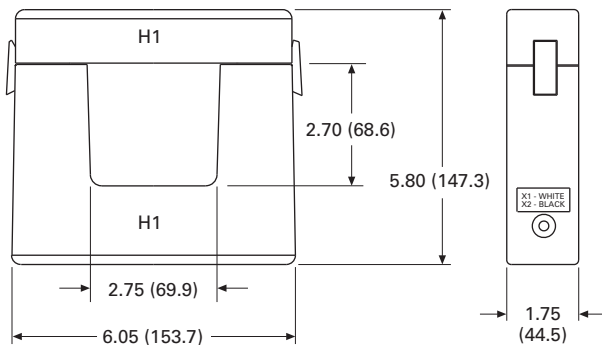
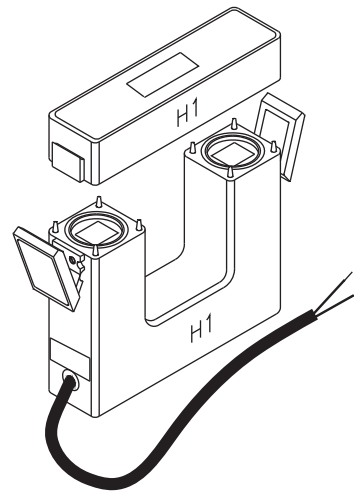

IQ Accessories—Clamp-On CTs

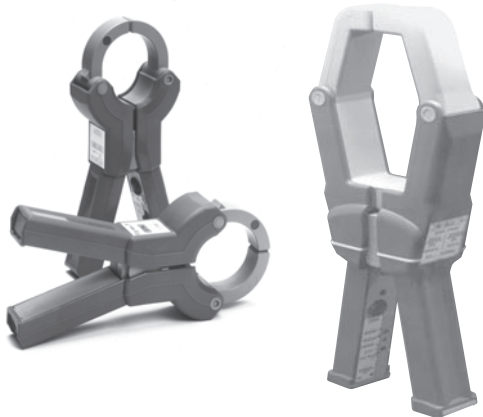

Contents

<i>Description</i>	<i>Page</i>
Metering Products Family	V3-T9-21
Power Xpert Meter 4000/6000/8000 Series	V3-T9-30
Power Xpert Meter 2000 Series	V3-T9-49
IQ 250/260 Series Electronic Power Meters	V3-T9-60
IQ 130/140/150 Series Electronic Power Meters	V3-T9-66
IQ 150S/250S Self-Enclosed Electronic Meters	V3-T9-71
IQ 35M	V3-T9-76
IQ Analyzer 6400/6600 Series	V3-T9-79
IQ DP-4000 Series	V3-T9-87
IQ 230 Meters	V3-T9-93
Power Xpert Multi-Point Meter	V3-T9-100
IQ Energy Sentinel™	V3-T9-112
PM3 Monitoring and Metering Module	V3-T9-121
Current Transformers (CTs)	V3-T9-122
Clamp-On Current Transformers	
Product Selection	V3-T9-132
Technical Data and Specifications	V3-T9-132
Dimensions	V3-T9-133
IQ Flange	V3-T9-134
Panel Mounting Adapter Kit	V3-T9-135
Enclosed Meters	V3-T9-136

Clamp-On Current Transformers

Product Description

Eaton’s optional Clamp-on Current Transformers (CTs) are designed to be used in cases where there are no existing CTs or the existing CTs cannot be accessed, these clamp-on CTs can be used.

These clamp-on CTs are packaged individually. Most applications will require at least three clamp-on CTs, one for each phase.

Application Description

- There are two models that cover current ranges from 150 to 1500 amperes
- These clamp-on CTs are designed to fit around 600 volt insulated cable and bus bar

Features, Benefits and Functions

- Each clamp-on CT comes with a 12-foot (3.7m) cable and twist lock connector
- All models have a 5 ampere output at three different primary current ratings



Standards and Certifications

- Meets IEC 1010-1 Category III
- CE mark for applications where European compliance is required



Product Selection

Ordering Information

Current Ranges	Current Ranges	Catalog Number
150-300-600A	150-300-600A	IQAPORT0600CT
		
500-1000-1500A	500-1000-1500A	IQAPORT1500CT
		

9

Technical Data and Specifications

- Operating temperature: 14°F to 122°F (-10°C to 50°C)
- Operating humidity: 5 to 90% maximum noncondensing
- Altitude: 10,000 ft (3048m)
- Environment: indoor use only
- Operating voltage: 600 Vac maximum
- Isolation test: 5.55 kV for 1 minute
- Current over range: 200% for 3 minutes
- Connector: twist-lock

Current Ranges

Each of the two models of clamp-on CTs has three primary current ranges. The primary current range is selected at the clamp-on by connecting to the indicated terminals.

150A/300A/600A Clamp-On CT Specifications

- Current ratings:
 - 150 to 5 amperes
 - 300 to 5 amperes
 - 600 to 5 amperes

500A/1000A/1500A Clamp-On CT Specifications

- Current ratings:
 - 500 to 5 amperes
 - 1000 to 5 amperes
 - 1500 to 5 amperes

Electrical Characteristics

Current Ranges	Load (Ohms)	Phase Shift (Degree)	Frequency Range (3%)	Frequency Range (-3 db)
150-600A	0.10-1.0	0.5-1.0	40-5000	30-10,000
500-1500A	0.01-4.0	0.5-1.0	40-2000	30-5000

Dimensions

Approximate Dimensions in Inches (mm)

150A/300A/600A Clamp-On CT

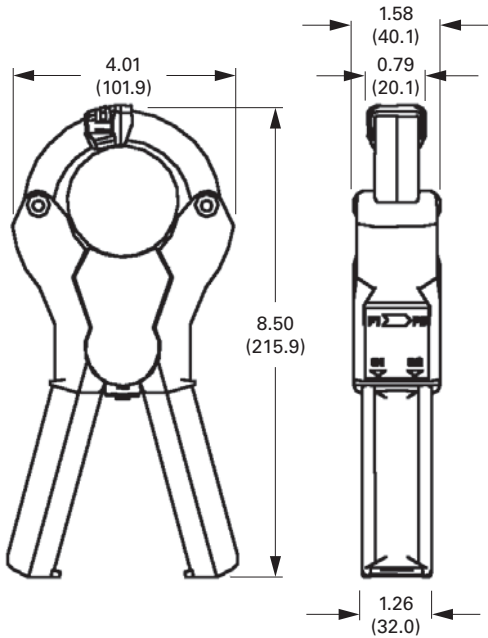

150A/300A/600A Clamp-On CT

- Maximum cable size:
 - 2.00 inches (50.8 mm)
- Maximum bus bar size:
 - 2.00 x 0.47 inches (50.8 x 12.0 mm)
 - 1.60 x 1.40 inches (40.6 x 35.6 mm)
- Dimensions (without cable):
 - 4.00 x 8.50 x 1.60 inches (101.6 x 215.9 x 40.6 mm)
- Weight (with cable):
 - 2.0 lbs (0.9 kg)

500A/1000A/1500A Clamp-On CT

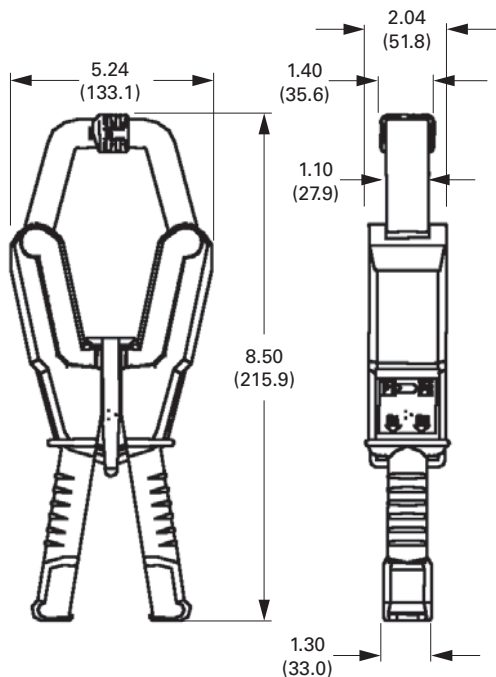

500A/1000A/1500A Clamp-On CT

- Maximum cable size:
 - 2.68 inches (68.1 mm)
- Maximum bus bar size:
 - 4.84 x 1.40 (122.9 x 35.6 mm)
 - 4.00 x 1.70 inches (101.6 x 43.2 mm)
- Dimensions (without cable):
 - 5.20 x 13.20 x 2.00 inches (132.1 x 335.3 x 50.8 mm)
- Weight (with cable):
 - 6.0 lbs (2.7 kg)

IQ Accessories—IQ Flange



IQ Flange

Product Description

Eaton's IQ Flange is intended for use with the IQ Data, IQ Generator, IQ Data Plus II, IQ Analyzer and any other such device sharing the same mounting dimensions.

The door mounting flange provides extra depth behind a panel if there is not enough clearance to accommodate the device.

Application Description

Retrofit Applications

For applications where extra door mounting space is required, a flange-mounting unit is available. The IQ Flange provides an extra 2.5 inches (63.5 mm) of clearance for the device. The IQ Flange can be used with any IQ device with a 5.38-inch (136.7 mm) x 9.38-inch (238.0 mm) cutout.

Contents

Description

Metering Products Family	V3-T9-21
Power Xpert Meter 4000/6000/8000 Series	V3-T9-30
Power Xpert Meter 2000 Series	V3-T9-49
IQ 250/260 Series Electronic Power Meters	V3-T9-60
IQ 130/140/150 Series Electronic Power Meters	V3-T9-66
IQ 150S/250S Self-Enclosed Electronic Meters	V3-T9-71
IQ 35M	V3-T9-76
IQ Analyzer 6400/6600 Series	V3-T9-79
IQ DP-4000 Series	V3-T9-87
IQ 230 Meters	V3-T9-93
Power Xpert Multi-Point Meter	V3-T9-100
IQ Energy Sentinel™	V3-T9-112
PM3 Monitoring and Metering Module	V3-T9-121
Current Transformers (CTs)	V3-T9-122
Clamp-On Current Transformers	V3-T9-131
IQ Flange	
Panel Mounting Adapter Kit	V3-T9-135
Enclosed Meters	V3-T9-136

Product Selection

IQ Flange



IQ Flange

Description	Catalog Number
IQ Flange	IQFLANGE

Panel Mounting Adapter Kit for IQ 100/200 Series and PXM 2000 Meters



Contents

Description

Metering Products Family	V3-T9-21
Power Xpert Meter 4000/6000/8000 Series	V3-T9-30
Power Xpert Meter 2000 Series	V3-T9-49
IQ 250/260 Series Electronic Power Meters	V3-T9-60
IQ 130/140/150 Series Electronic Power Meters	V3-T9-66
IQ 150S/250S Self-Enclosed Electronic Meters	V3-T9-71
IQ 35M	V3-T9-76
IQ Analyzer 6400/6600 Series	V3-T9-79
IQ DP-4000 Series	V3-T9-87
IQ 230 Meters	V3-T9-93
Power Xpert Multi-Point Meter	V3-T9-100
IQ Energy Sentinel™	V3-T9-112
PM3 Monitoring and Metering Module	V3-T9-121
Current Transformers (CTs)	V3-T9-122
Clamp-On Current Transformers	V3-T9-131
IQ Flange	V3-T9-134
Panel Mounting Adapter Kit Enclosed Meters	V3-T9-136

Panel Mounting Adapter Kit for IQ 100/200 Series and PXM 2000 Meters

Product Description

The flange adapter plate can be installed as follows:

1. Remove the old meter from the panel or door. Many IQ metering products use the typical IQ drilling pattern shown at right for mounting
2. Install the flange adapter plate. Mount it from the rear using the six screws provided in the kit. The flange adapter plate screw hole pattern shown at right should match the typical IQ drilling pattern. If not, perform the next step
3. Drill six holes in the panel or the door to mount the flange adapter plate. Follow the typical IQ drilling pattern. You need only the top, center and bottom sets of holes
4. Install the new IQ 100/200 Series or PXM 2000 meter in the flange adapter plate. Secure it from behind with four flat washers, lock washers and nuts provided with the meter

Product Selection

Panel Mounting Adapter Kit



Panel Mounting Adapter Kit

Description	Catalog Number
Panel mounting adapter kit IQ 100/200 and PXM 2000 Series adapter kit to IQ Analyzer/IQ DP-4000/IQ Data	IQ250-PMAK

Dimensions

Flange Adapter Plate Screw Hole Pattern

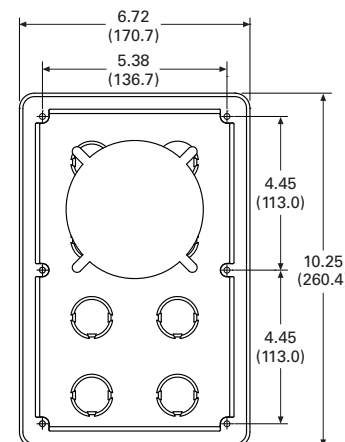

NEMA 12 Single- and Multi-Unit Enclosed Meters



Enclosed Meters

Product Description

The Eaton enclosed meter line provides a complete energy metering and data acquisition solution in a single enclosure. Designed for Eaton's IQ 35M, IQ 150, IQ 250/260, and Power Xpert® 2000/4000/6000/8000 and Multi-Point Meters, Eaton's enclosed meter line offers mounting and installation flexibility, especially in retrofit applications where no metering compartment or mounting space is available in the existing electrical distribution equipment or where installation time is a premium. Factory designed and wired, Eaton's enclosed meter line offers savings in labor and installation costs because input current and voltage wiring as well as I/O wiring is prewired to terminal blocks inside the enclosure.

The enclosed meter line has two standard offerings: single-, prewired unit (specific IQ 150, IQ 250/260, PXM 2000, PXM 4000/6000/8000 or PXMP) and a multi-unit (specific IQ 150, IQ 250/260 or IQ 35M models). Because the multi-unit automatically includes Eaton's Power Xpert Gateway 200E, it facilitates measurement and verification of the energy usage on processes and in buildings. This provides a convenient way to monitor energy usage from multiple points, collect and log specific energy use parameters, and display and generate logs for historical energy usage reports. Simply put, Eaton's multi-unit enclosed meter solution helps meet any measurement and verification requirement to show energy efficiency improvements and results. In addition to the standard offering, Eaton can also provide an enclosed metering solution tailored around your project needs.

Contents

Description

Metering Products Family	V3-T9-21
Power Xpert Meter 4000/6000/8000 Series	V3-T9-30
Power Xpert Meter 2000 Series	V3-T9-49
IQ 250/260 Series Electronic Power Meters	V3-T9-60
IQ 130/140/150 Series Electronic Power Meters	V3-T9-66
IQ 150S/250S Self-Enclosed Electronic Meters	V3-T9-71
IQ 35M	V3-T9-76
IQ Analyzer 6400/6600 Series	V3-T9-79
IQ DP-4000 Series	V3-T9-87
IQ 230 Meters	V3-T9-93
Power Xpert Multi-Point Meter	V3-T9-100
IQ Energy Sentinel™	V3-T9-112
PM3 Monitoring and Metering Module	V3-T9-121
Current Transformers (CTs)	V3-T9-122
Clamp-On Current Transformers	V3-T9-131
IQ Flange	V3-T9-134
Panel Mounting Adapter Kit	V3-T9-135
Enclosed Meters	
Features and Benefits	V3-T9-137
Catalog Number Selection	V3-T9-139
Product Selection	V3-T9-139
Technical Data and Specifications	V3-T9-140
Wiring Diagrams	V3-T9-141
Dimensions	V3-T9-151

Application Description

Factory designed and wired to fit various Eaton power and energy meters at varying price points, Eaton's enclosed meter line offers savings in labor and installation costs because input current and voltage wiring, as well as I/O wiring, is prewired to terminal blocks inside the enclosure. Standalone, enclosed meters are ideal for new metering applications where no metering existed previously, for retrofit installations where energy monitoring is a must or where ease of installation is required.

- Health care facilities
- Educational facilities and campuses
- Industrial facilities
- Commercial facilities
- Government facilities

The multi-unit offering consolidates energy-related data available from the meters in the enclosure, but also allows for external meters to be added to the embedded Power Xpert Gateway 200E. Through the Power Xpert Gateway 200E's embedded Web server, information can be presented in a variety of ways; a standard Web browser being the most widely used method.

The enclosed product is a standalone solution that is ideal for many infrastructure designs. Further, as needs change and grow, the enclosed product can be integrated through Power Xpert Software into a broader solution that encompasses other intelligent hardware and can integrate with third-party network management systems (NMS) or building management systems (BMS) for system-wide monitoring and reporting of energy and power.

Features and Benefits

- Saves installation time and cost
- One part number to order; no need to worry that any part has been left out
- Pick the meter or meters you need as it is designed to fit various Eaton power and energy meters, at varying price points

Factory Wired

Most electrical contractors are very familiar with wiring meters. However, it does take time to place the disconnect, the CT shorting blocks, the terminal blocks, the control power transformer and so on, and the associated wiring. It is not uncommon for errors to be introduced during the installation of multiple meters; it's just inherent in wiring. With Eaton's enclosed meter line, everything is wired at the factory—the shorting block, the terminal blocks and so on—assuring that it's done right. Further, to ensure safety, Eaton's enclosed meter line includes a primary fusible disconnect for line voltage, which can be turned off during meter maintenance.

For applications with line voltages above the rated power supply of the meter, an optional control power transformer is supplied in the enclosure. Control voltage can also be supplied via a separate source that is wired to the field installation terminal block. CT inputs for the meter are wired directly to the shorting terminal blocks for easy field installation.

Factory-wired products also save on installation time and costs. The meters are flush mounted on the enclosure door with all inputs/outputs factory wired to the terminal blocks.

A meter subpanel assembly is also available, which includes all the internal components of the single-unit enclosed meter for the IQ 150/250/260 and PXM 2000 Meters wired and mounted on a subpanel to be installed into an existing electrical structure. It comes with a 48-inch lead for flexibility in mounting the meters at various distances.

NEMA Rated

NEMA 12 enclosure prevents dust and other materials from entering the equipment. Internal gaskets also prevent air irritants from harming the vital equipment inside. This quality enclosure meets most indoor application needs.

NEMA 3R enclosure is constructed for either indoor or outdoor use. It helps to protect personnel from access to hazardous parts and provides a degree of protection for equipment inside the enclosure against ingress of solid foreign objects (falling dirt), harmful effects of water (rain, sleet, snow) and external formation of ice on the enclosure.

NEMA 4X enclosure provides the same degree of protection as the NEMA 3R with the additional protection against windblown dust, splashing and hose-directed water, and corrosion.

NEMA 12 Front View, Door Open, Prewired and Tested

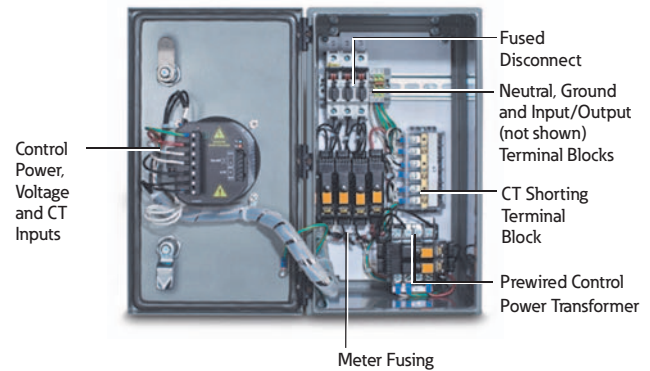

NEMA 12 Multi-Unit View, Door Open, Prewired and Tested

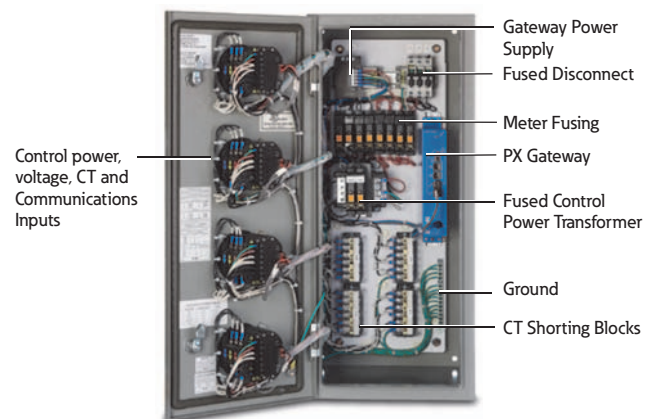

NEMA 12 Single-Unit Enclosed Meter Inside View, PXM 4000/6000/8000 Series

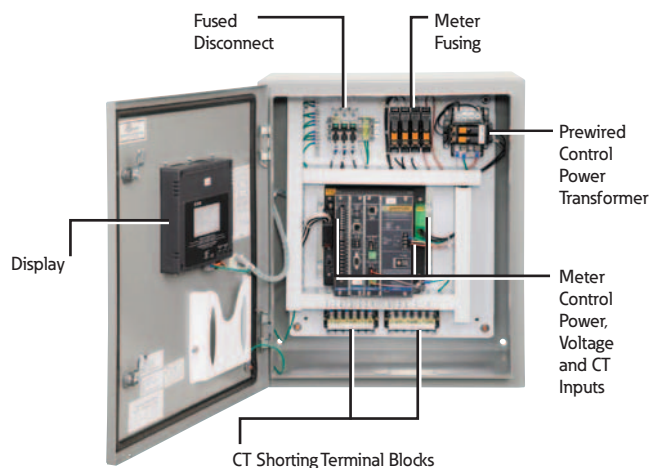

NEMA 3R Single-Unit Closed and Open, IQ 150/250/260 and PXM 2000 Series

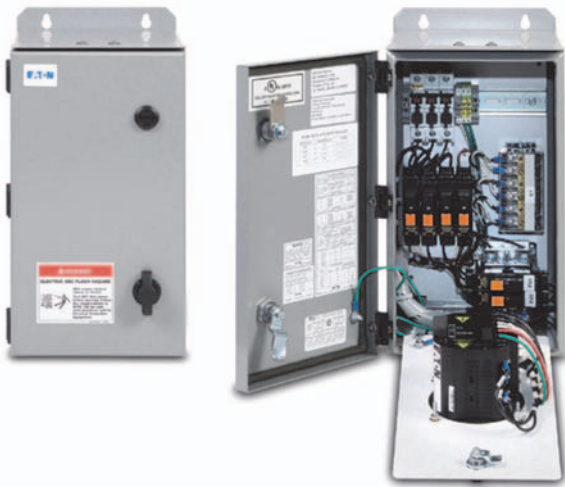

NEMA 4X Single-Unit Closed and Open, IQ 150/250/260 and PXM 2000 Series



Enclosed Power Xpert Multi-Point Meter

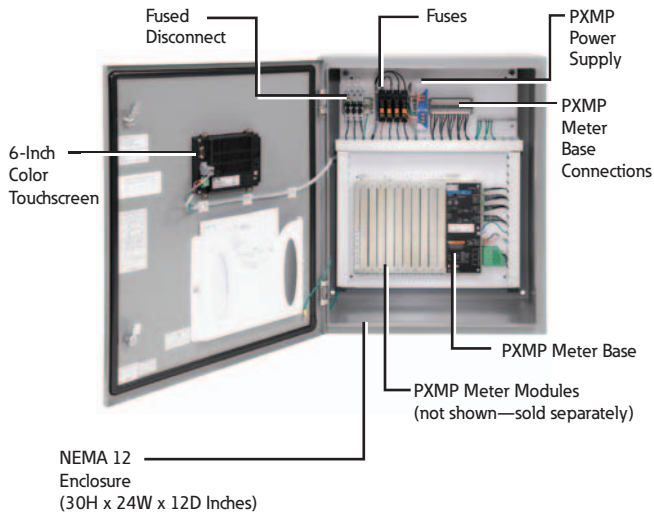

Multi-Unit Enclosed Meter, Inside View of IQ 35M

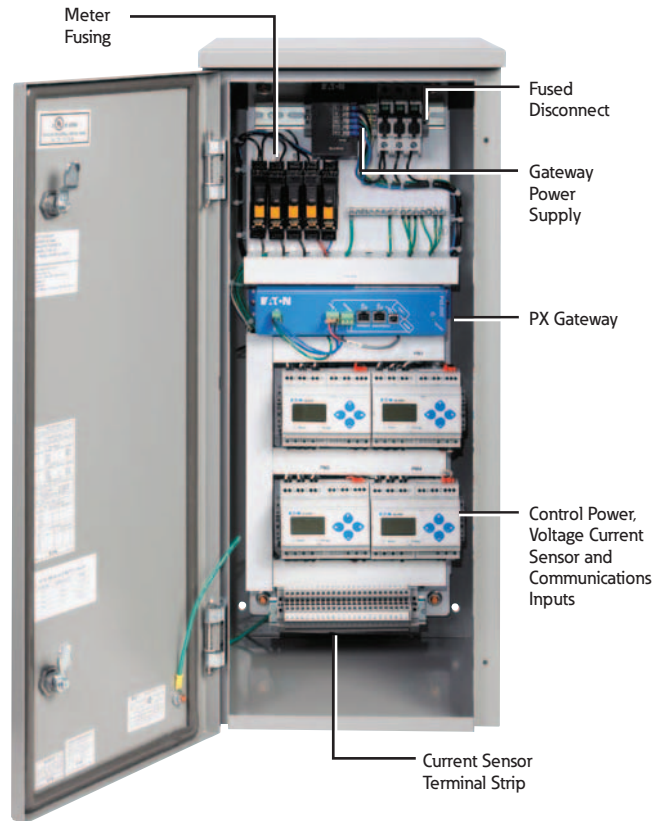

Prewired Meter Backpan, Single Unit

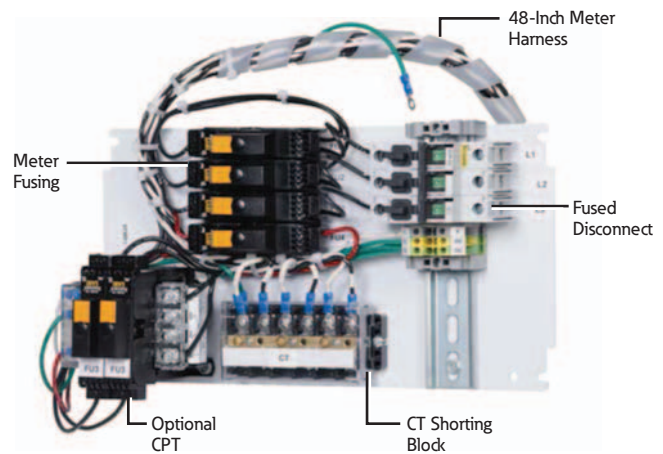

- Prewired panel to save installation time and cost for retrofits into existing equipment
- Designed for Eaton's:
 - IQ 100 Meter Series
 - IQ 250/260
 - Power Xpert Meter 2000 Series
- With or without CPT, depending on voltage
- Order meters separately

Catalog Number Selection

Single Unit Enclosed Meter

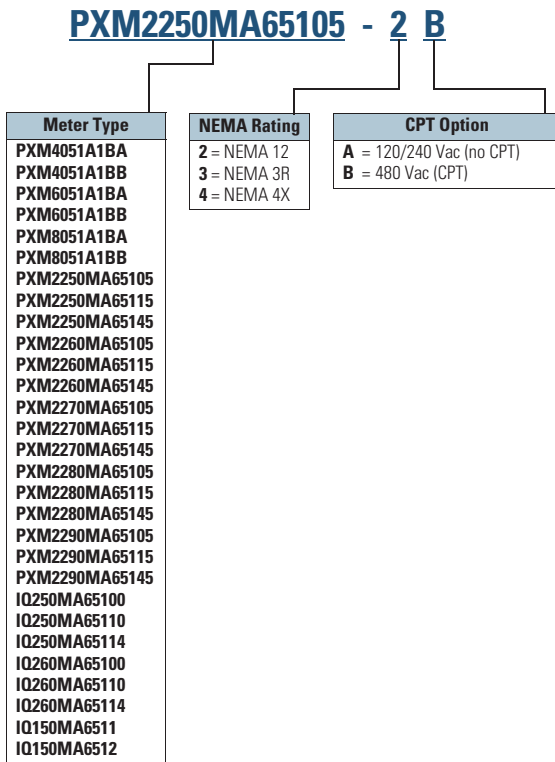

Enclosed PXMP Meter

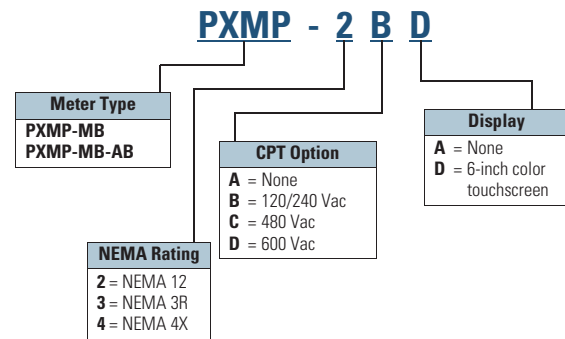

Multi Unit Enclosed Meter

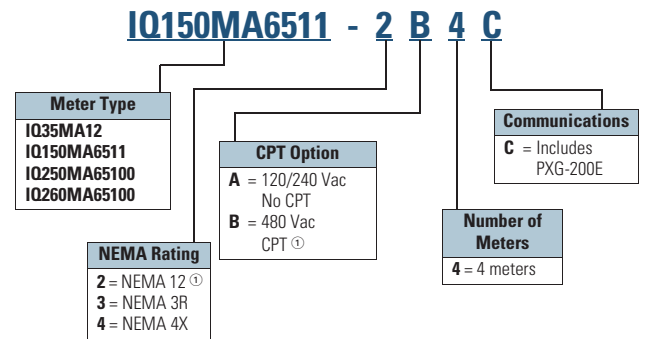

Product Selection

Meter Subpanel Assembly

Description	Catalog Number
Meter subpanel assembly for PXM 2000 and IQ 150/250/260 Meters	PXM2K-MSPA-A
Meter subpanel assembly with CPT for PXM 2000 and IQ 150/250/260 Meters	PXM2K-MSPA-B

Notes

① Not available with IQ 35M.

Other meter models available upon request in single- and multi-unit enclosed versions.

Technical Data and Specifications

Enclosed Meters

Description	Specification
Enclosure rating	NEMA 12, 3R, 4X
Enclosure operating temperature	–20°C to +40°C Note: Temperature range of meter is –20°C to +70°C. If applied outside, proper precautions should be taken to avoid exceeding the maximum and minimum temperature ratings of the meter.
Dimensions	Single unit (IQ 150/250/260 and PXM 2000): NEMA 12 (8.00W x 16.30H x 10.40D inches), NEMA 3R/4X (8.00W x 16.30H x 9.60D inches) Single unit (PXMP): NEMA 12/3R/4X (24.00W x 30.00H x 12.00D inches) Single unit (PXM 4000/6000/8000): NEMA 12 (20.00W x 24.00H x 14.10D inches) NEMA 3R/4X (20.20W x 24.00H x 13.90D inches) Multi unit: NEMA 12 (13.00W x 30.00H x 15.20D inches) NEMA 3R (13.20W x 30.10H x 14.60D inches) NEMA 4X (13.00W x 30.00H x 14.00D inches)
Meters	Single unit: IQ 150, IQ 250/260, PXM 2000/4000/6000/8000 and PXMP models Multi unit: IQ 35M, IQ 150 and IQ 250/260
Communications (multi unit only)	Power Xpert Gateway 200E
Control voltage	120V–600V (PXMP)—power supply required Up to 240V (IQ 35M/150/250/260 and PXM 2000/4000/6000/8000)—no CPT required Greater than 240V (IQ 150/250/260 and PXM 2000)—CPT required Separate source control—no CPT required
Basic model	Fusible disconnect—primary voltage Shorting block(s)—not required for IQ 35M or PXMP Ground terminal block Neutral terminal block Eight-point terminal block(s) for input/output modules for IQ 250/260 and PXM 2000
Wiring	Wired for three-phase, four-wire applications. Three-phase, three-wire applications—will need to change the wiring for both the voltage and the current per the wiring diagram in the meter instruction manual.
Certifications	UL® 508A and cUL®
Source control	No separate source control voltage required for applications below 240 Vac (except PXMP)
Prewired	Prewired current transformer, shorting terminal block(s), neutral, ground, voltage, control power, fusible disconnect and input/output terminal block(s)
Latch	Padlocking latch provision
Optional features	Control power transformer—single unit: 50 VA (IQ 150/250/260) and 150 VA (PXM 4000/6000/8000); multi unit: 250 VA control power supply for meter where monitored voltage is 480 Vac (IQ 150/250/260 and PXM 2000/4000/6000/8000)

Note: Specifications are subject to change without notice and represent the maximum capabilities of the product with all options installed. This is not a complete feature list. Features and functionality may vary depending on selected options, firmware version and product model. Please refer to the technical data sheet and the user manual for detailed specifications.

Wiring Diagrams

Single Unit Enclosure—200/240 Vac 50/60 Hz, Three-Phase, Four-Wire System with IQ 150/250/260 or PXM 2000 Meter

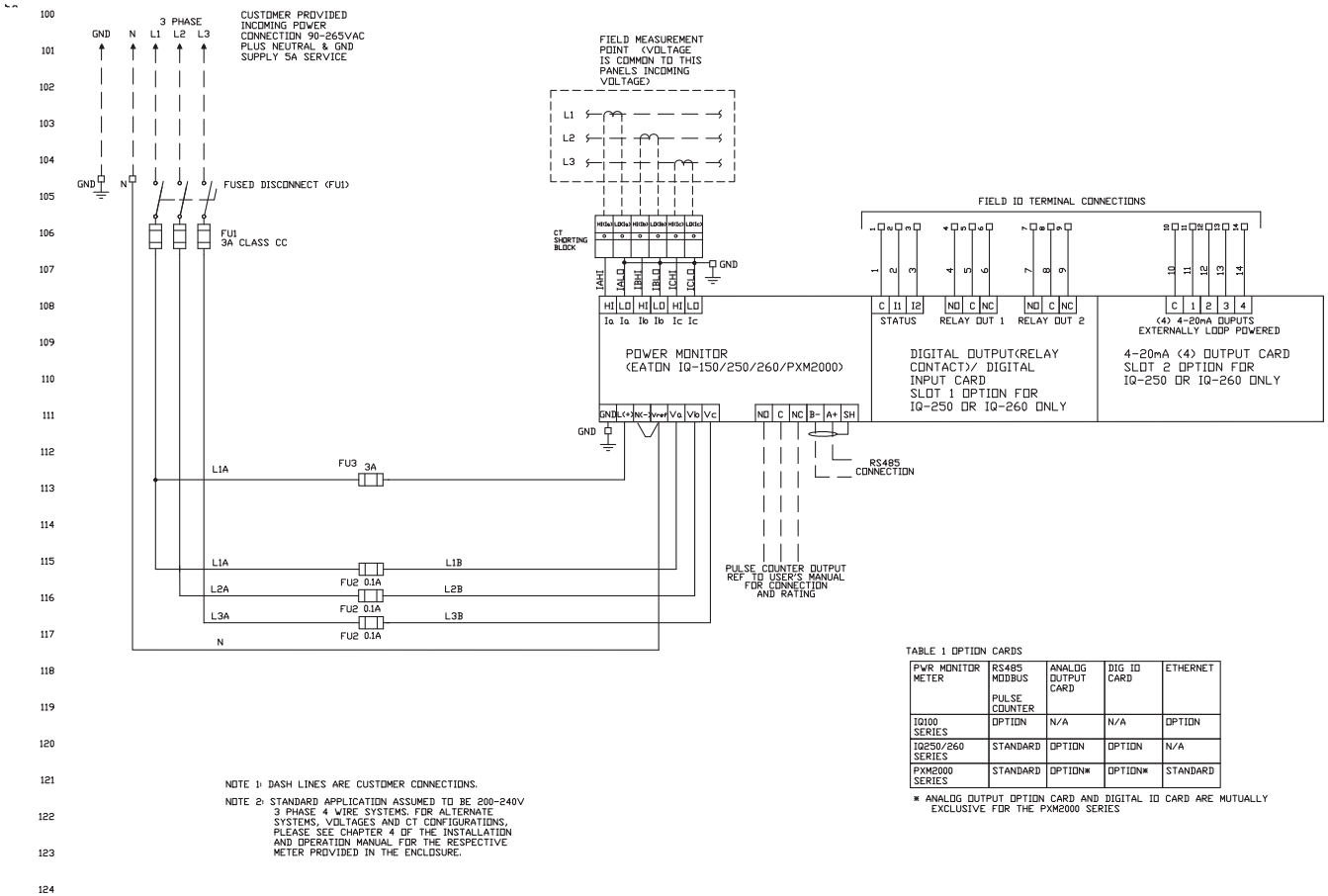

Single Unit Enclosure—480 Vac 50/60 Hz, Three-Phase, Four-Wire System with IQ 150/250/260 or PXM 2000 Meter

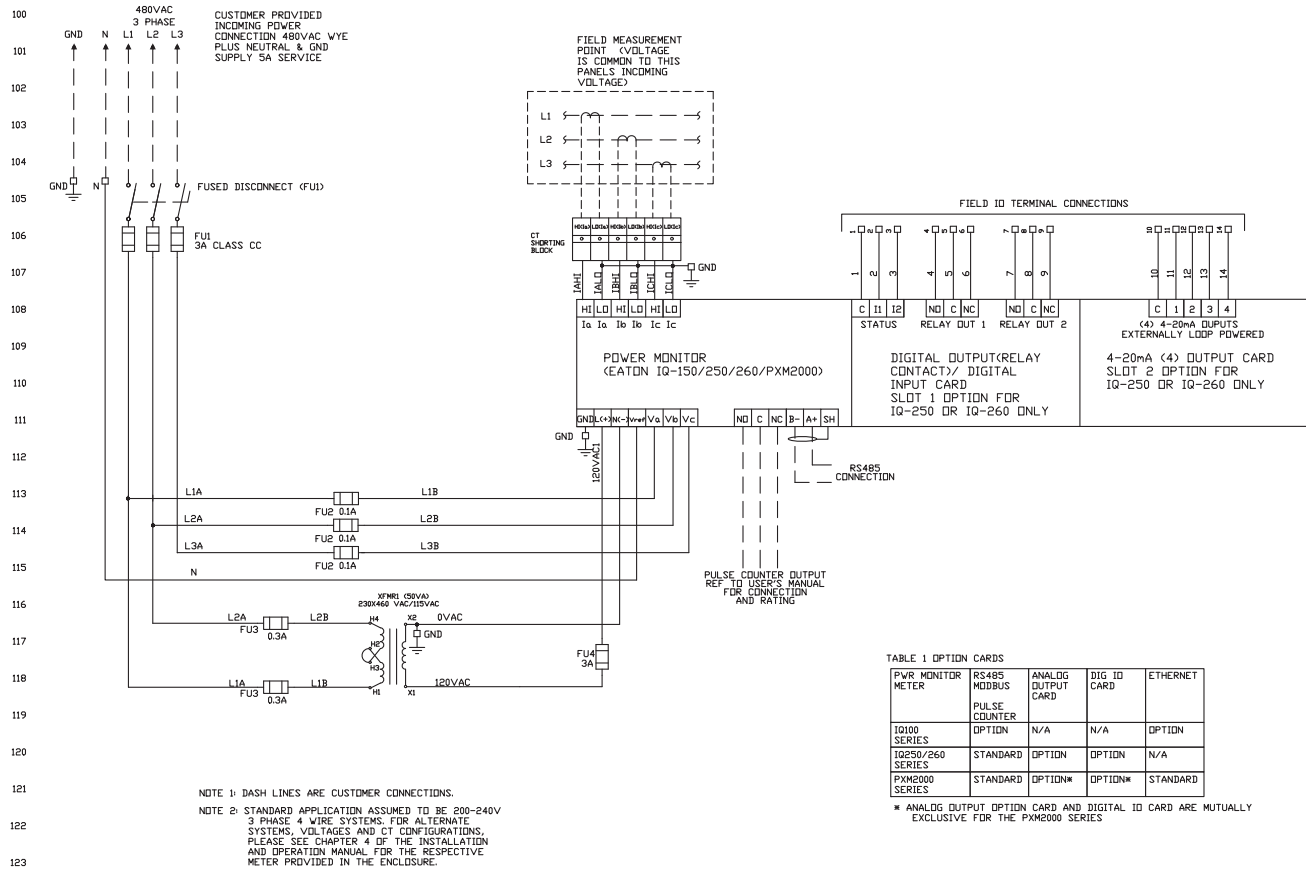

Multi Unit Enclosure—200–240 Vac 50/60 Hz, Three-Phase, Four-Wire System with IQ 35M Meters

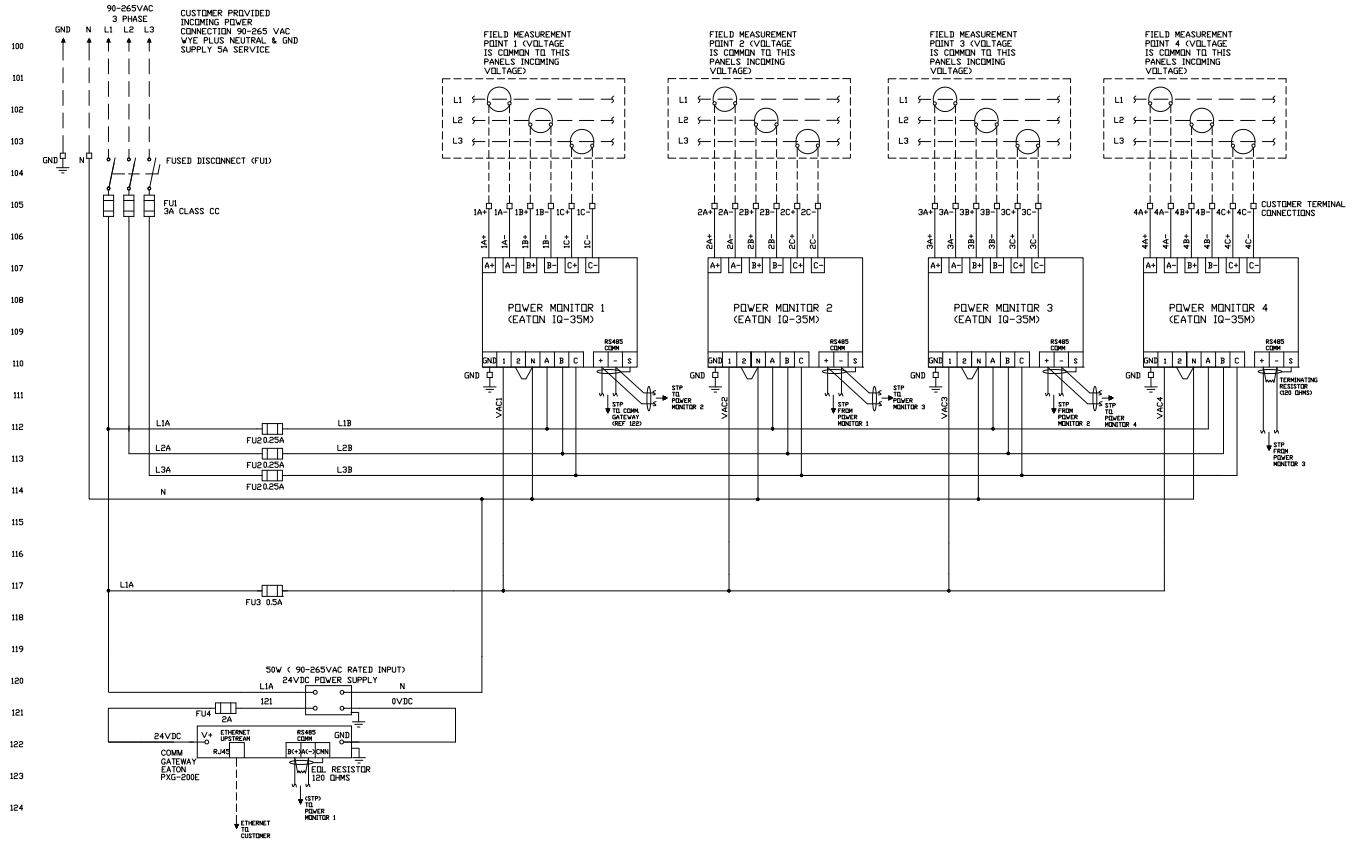

Multi Unit Enclosure—200–240 Vac 50/60 Hz, Three-Phase, Four-Wire System with IQ 150/250/260 Meters

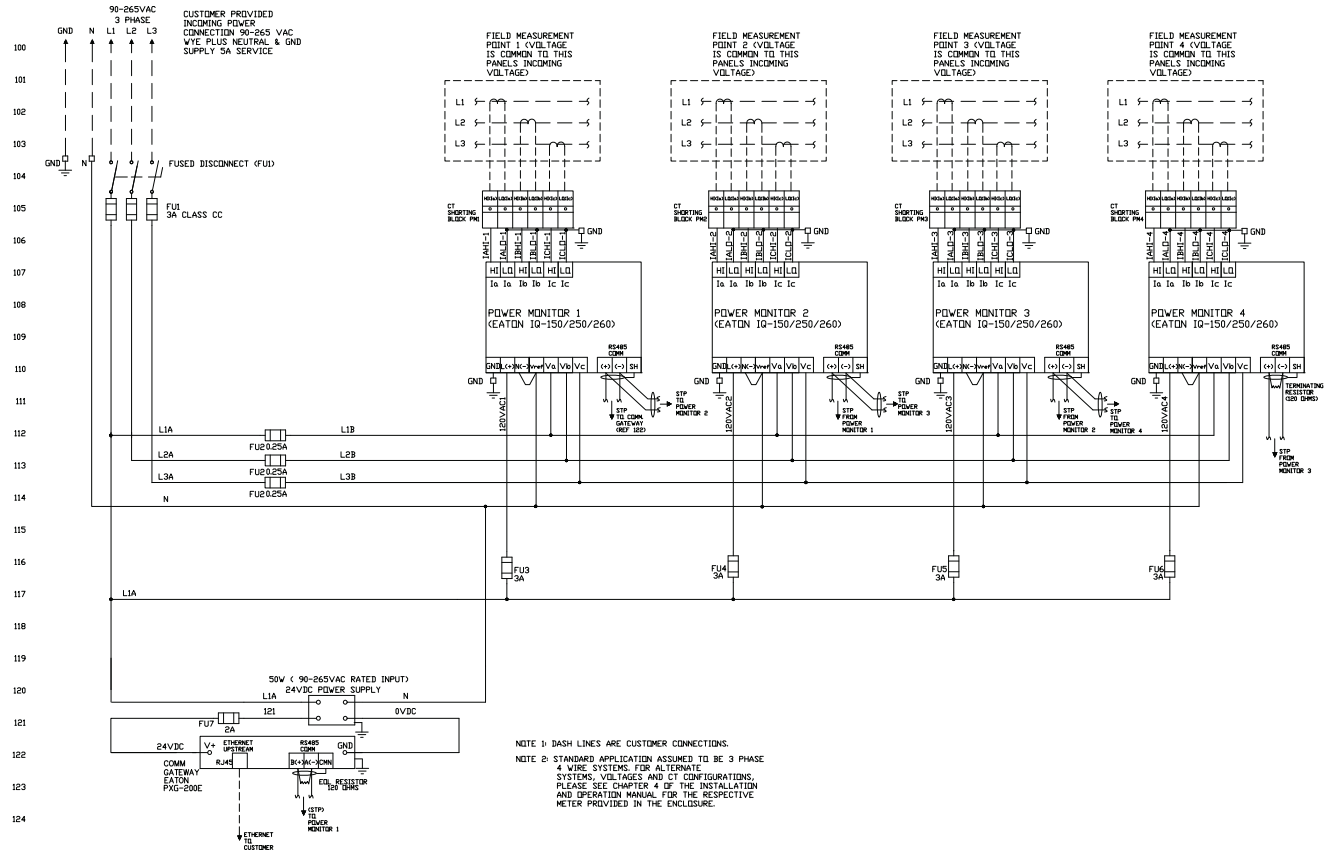

Multi Unit Enclosure—480 Vac 50/60 Hz, Three-Phase, Four-Wire System with IQ 150/250/260 Meters

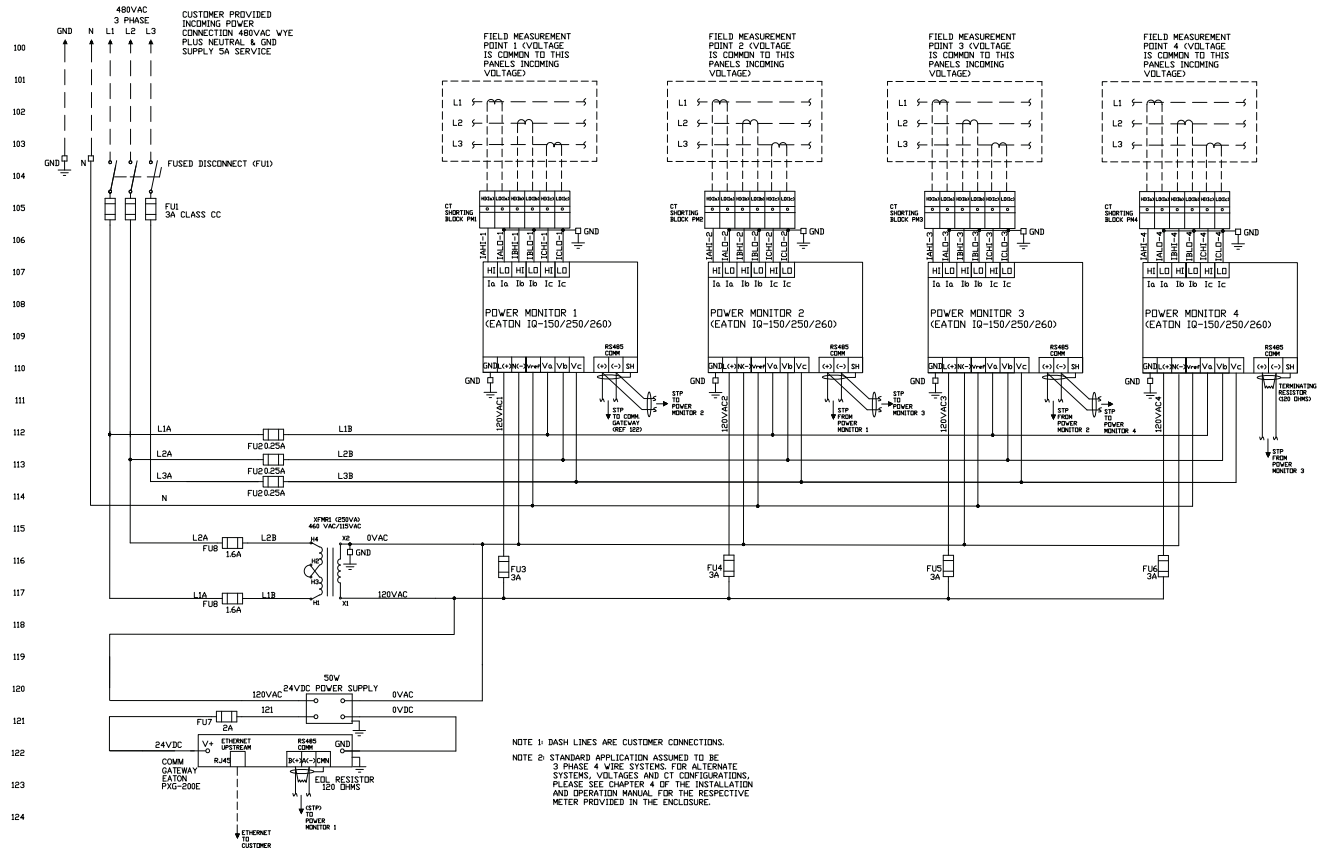

Single Unit Enclosure—120–240 Vac 50/60 Hz, Three-Wire System with PXMP Meter

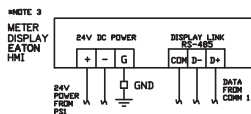
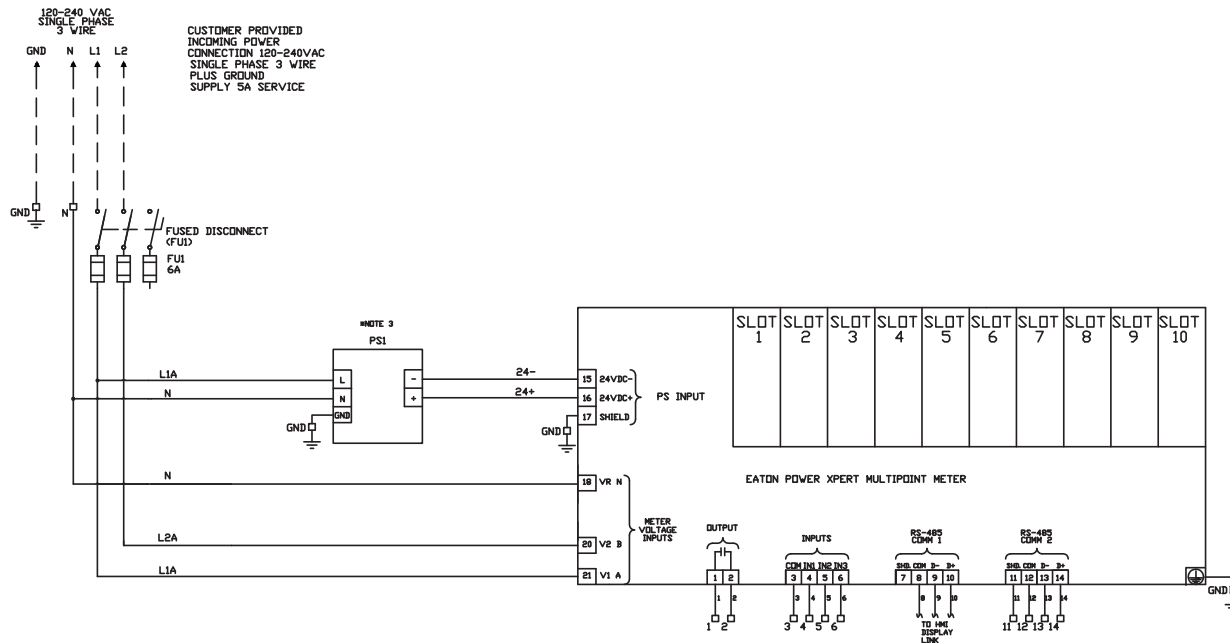

NOTE 1: DASH LINES ARE CUSTOMER CONNECTIONS.
 NOTE 2: STANDARD APPLICATION ASSUMED TO BE SINGLE PHASE, 3 WIRE SYSTEMS. FOR ALTERNATE SYSTEMS, VOLTAGES AND CT CONFIGURATIONS, PLEASE SEE CHAPTER 4 OF THE PXMP INSTALLATION AND OPERATION MANUAL, MNIS0001EN.
 NOTE 3: THIS OPTION WILL ONLY BE PRESENT IF PURCHASED

Single Unit Enclosure—120–240 Vac 50/60 Hz, Three-Phase, Four-Wire Wye System with PXMP Meter

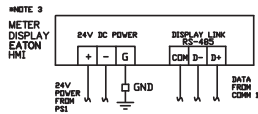
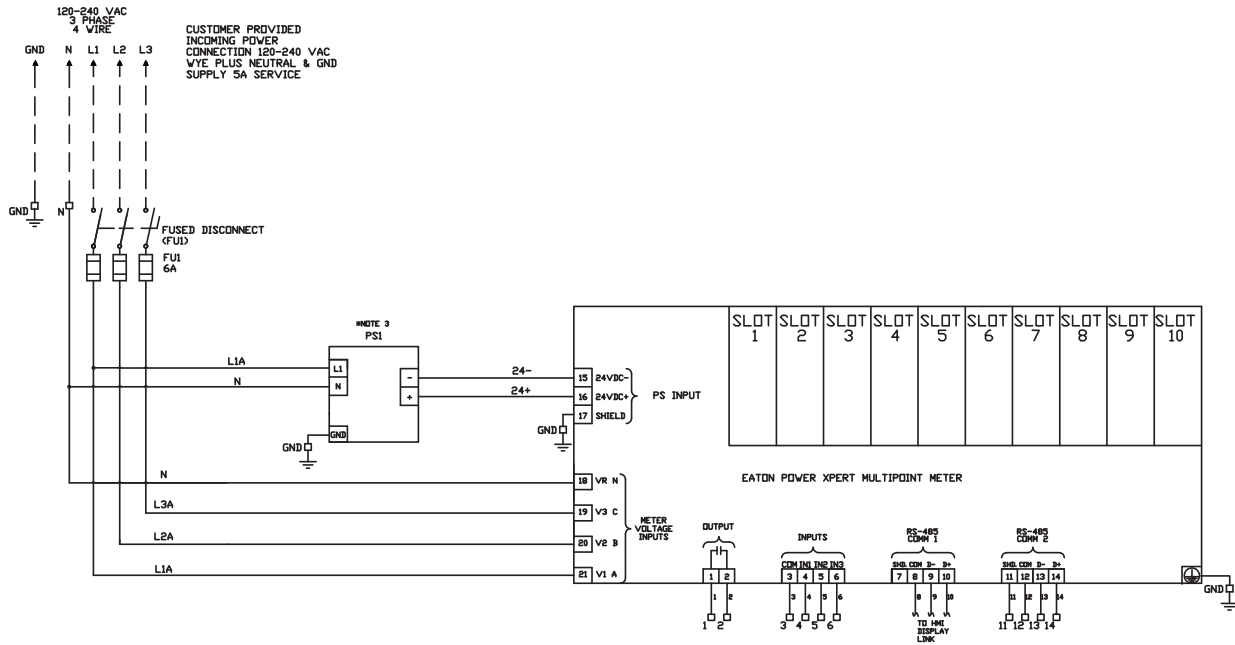

NOTE 1: DASH LINES ARE CUSTOMER CONNECTIONS.
 NOTE 2: STANDARD APPLICATION ASSUMED TO BE 120-240V 3 PHASE 4 WIRE SYSTEMS. FOR ALTERNATE SYSTEMS, VOLTAGES AND CT CONFIGURATIONS, PLEASE SEE CHAPTER 4 OF THE PXMP INSTALLATION AND OPERATION MANUAL, MN150001EN
 NOTE 3: THIS OPTION WILL ONLY BE PRESENT IF PURCHASED

Single Unit Enclosure—480–600 Vac 50/60 Hz, Three-Phase, Four-Wire Wye System with PXMP Meter

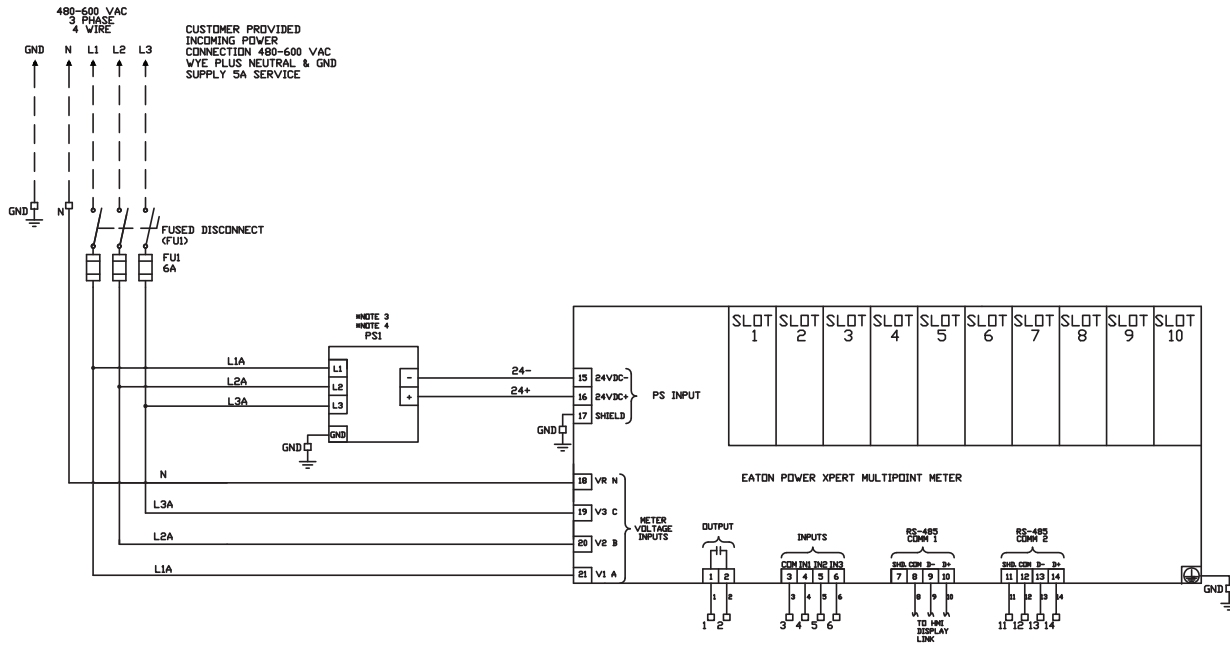

Single Unit Enclosure—200–240 Vac 50/60 Hz, Three-Phase, Four-Wire System with PXM 4000/6000/8000 Meter

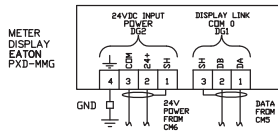
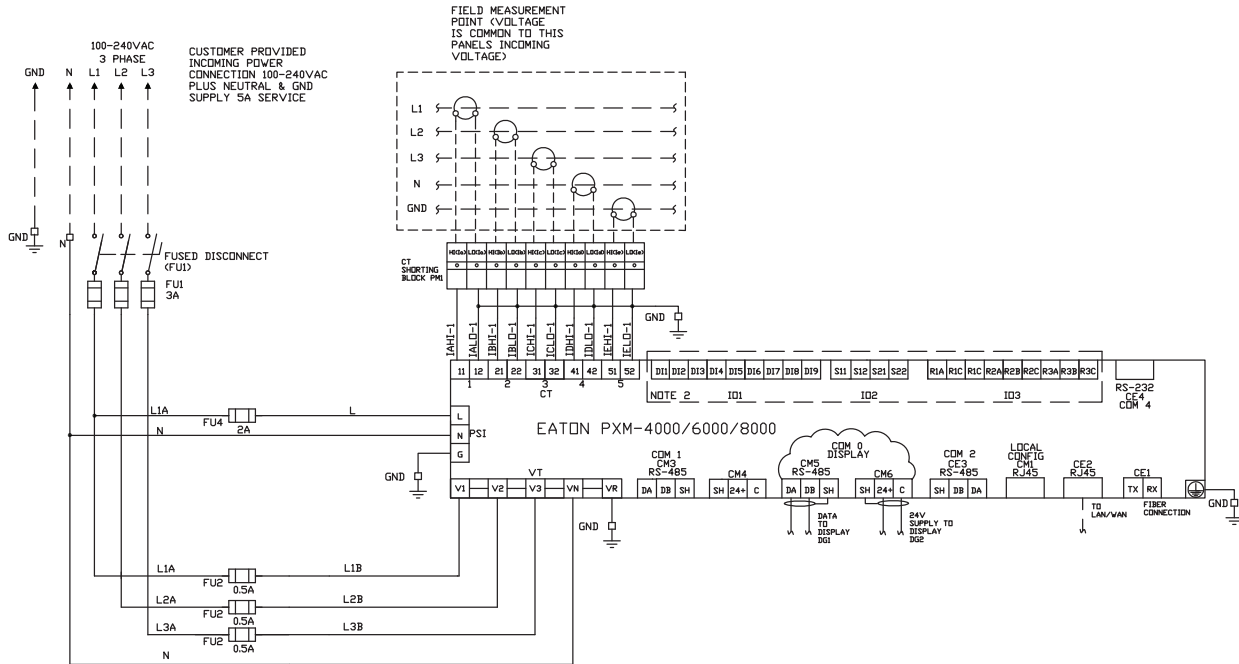

NOTE 1: DASH LINES ARE CUSTOMER CONNECTIONS.
NOTE 2: STANDARD APPLICATION ASSUMED TO BE 100-240VAC
3 PHASE 4 WIRE SYSTEMS. FOR ALTERNATE
SYSTEMS, VOLTAGES AND CT CONFIGURATIONS,
PLEASE SEE CHAPTER 4 OF THE INSTALLATION
AND OPERATION MANUAL FOR THE RESPECTIVE
METER PROVIDED IN THE ENCLOSURE.
NOTE 3: THIS OPTION WILL ONLY BE PRESENT IF PURCHASED

9.3

Metering Devices, Protective Relays, Software and Connectivity

Metering Devices

Single Unit Enclosure—480 Vac 50/60 Hz, Three-Phase, Four-Wire System with PXM 4000/6000/8000 Meter

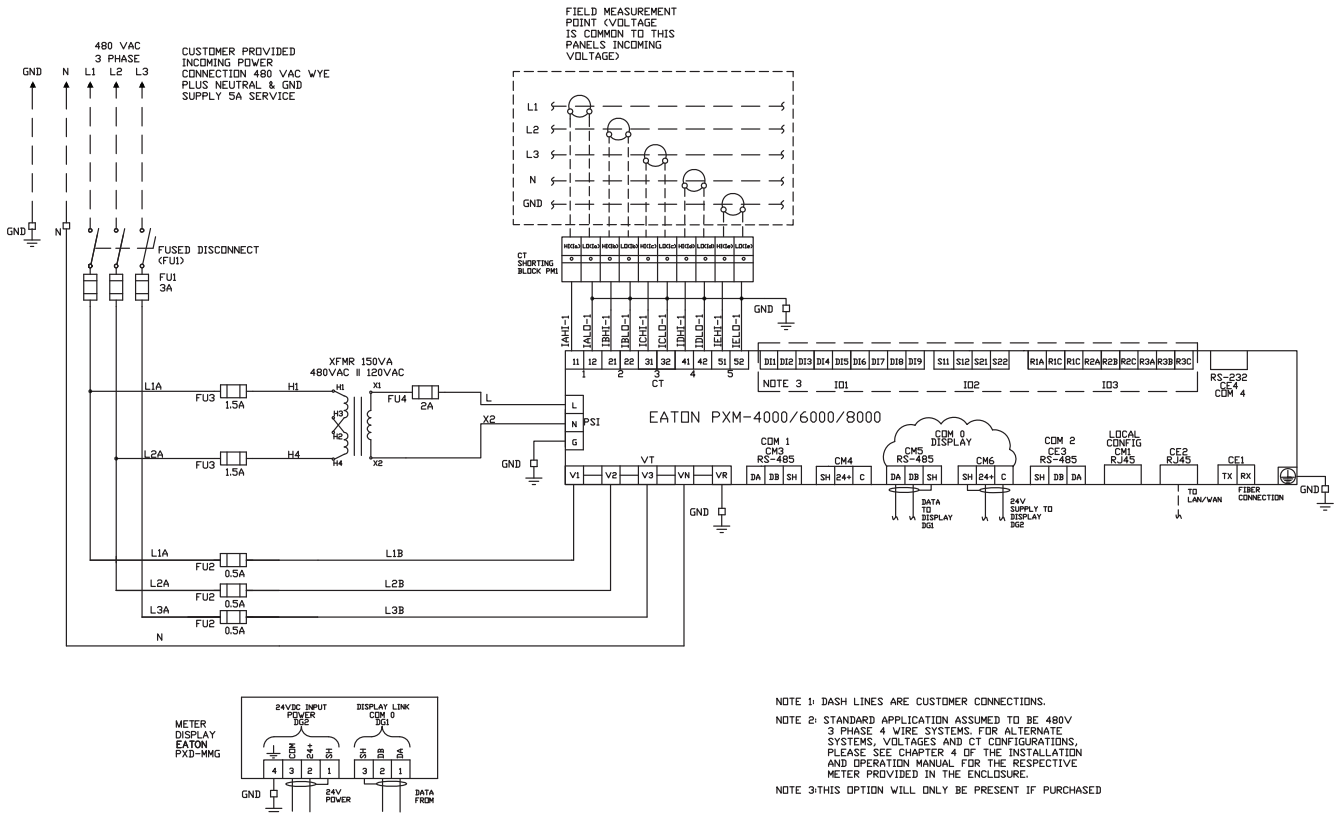

9

Dimensions

Approximate Dimensions in Inches (mm)

NEMA 12 Single Unit Enclosure

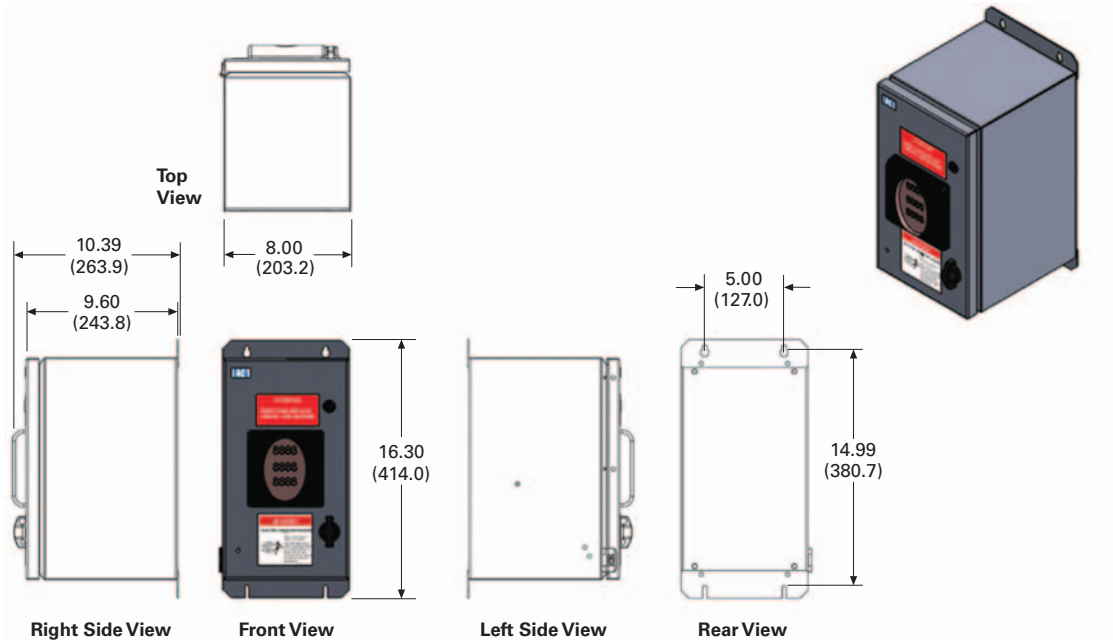

NEMA 12 Multi Unit Enclosure

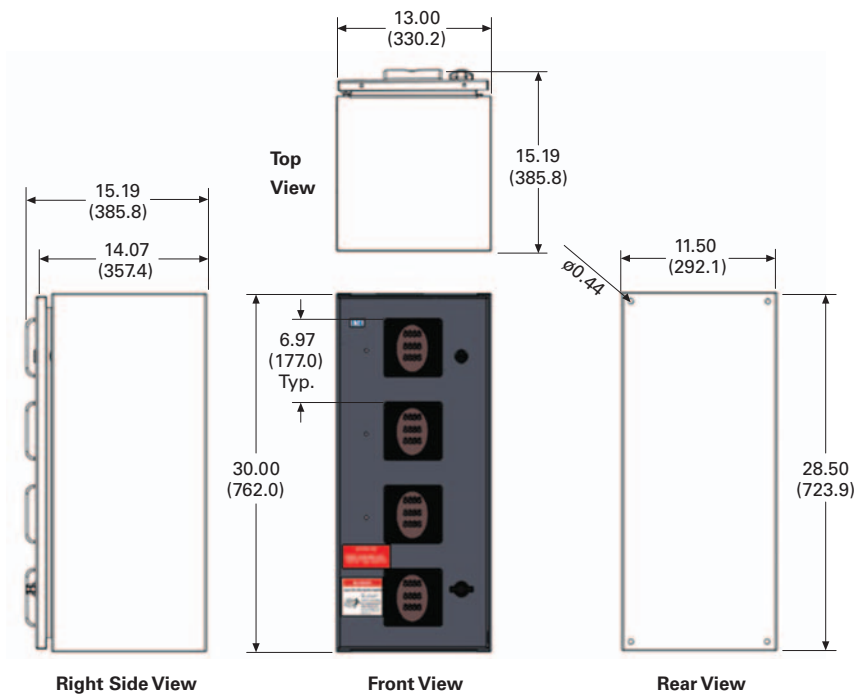

9.3

Metering Devices, Protective Relays, Software and Connectivity

Metering Devices

Approximate Dimensions in Inches (mm)

NEMA 12 PXM 4000/6000/8000 Enclosure

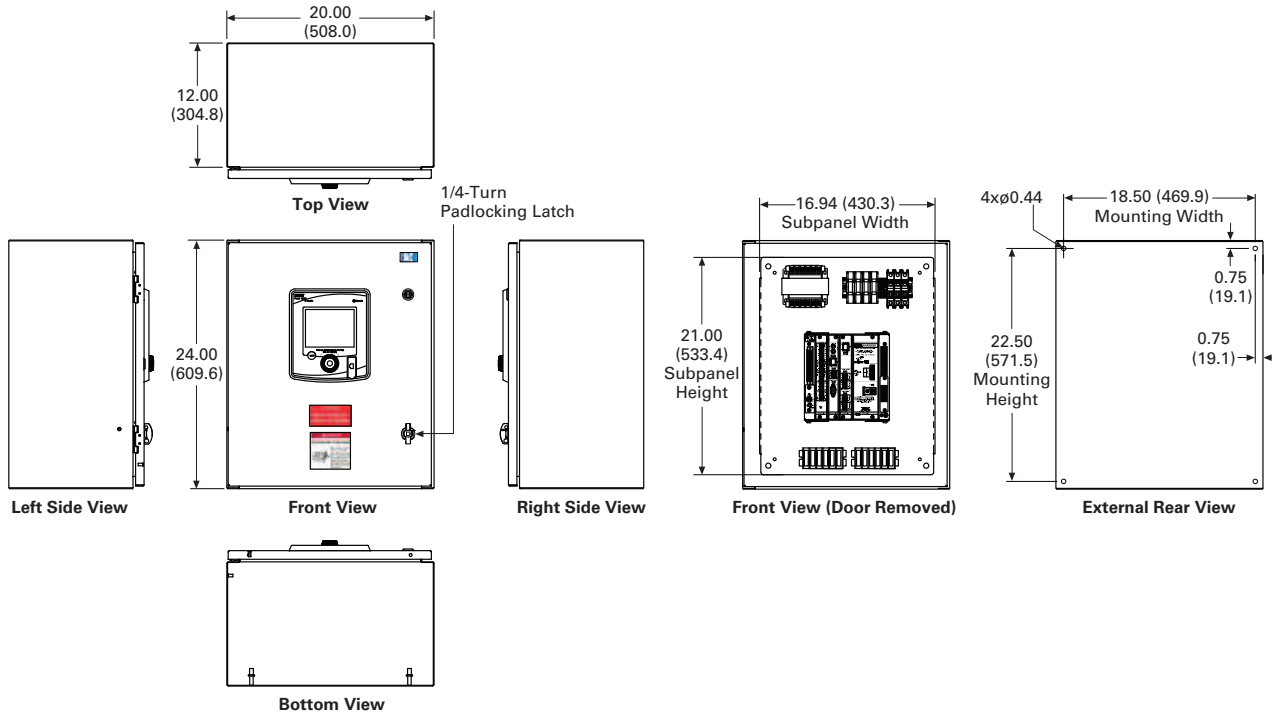

9

NEMA 12 PXMP Enclosure

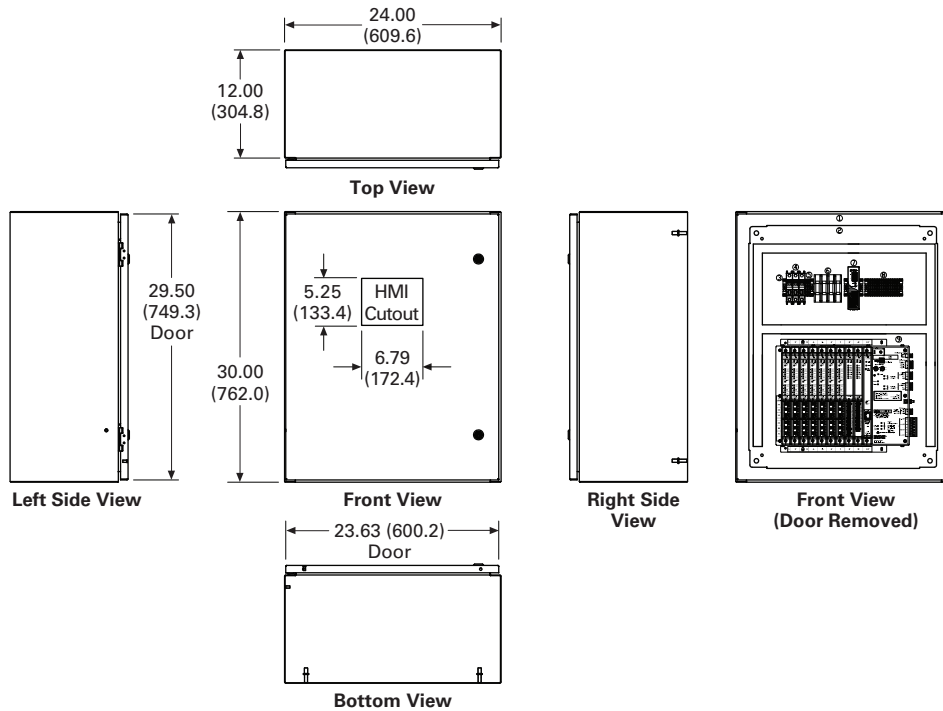

Approximate Dimensions in Inches (mm)

NEMA 3R/4X Single Unit Enclosure

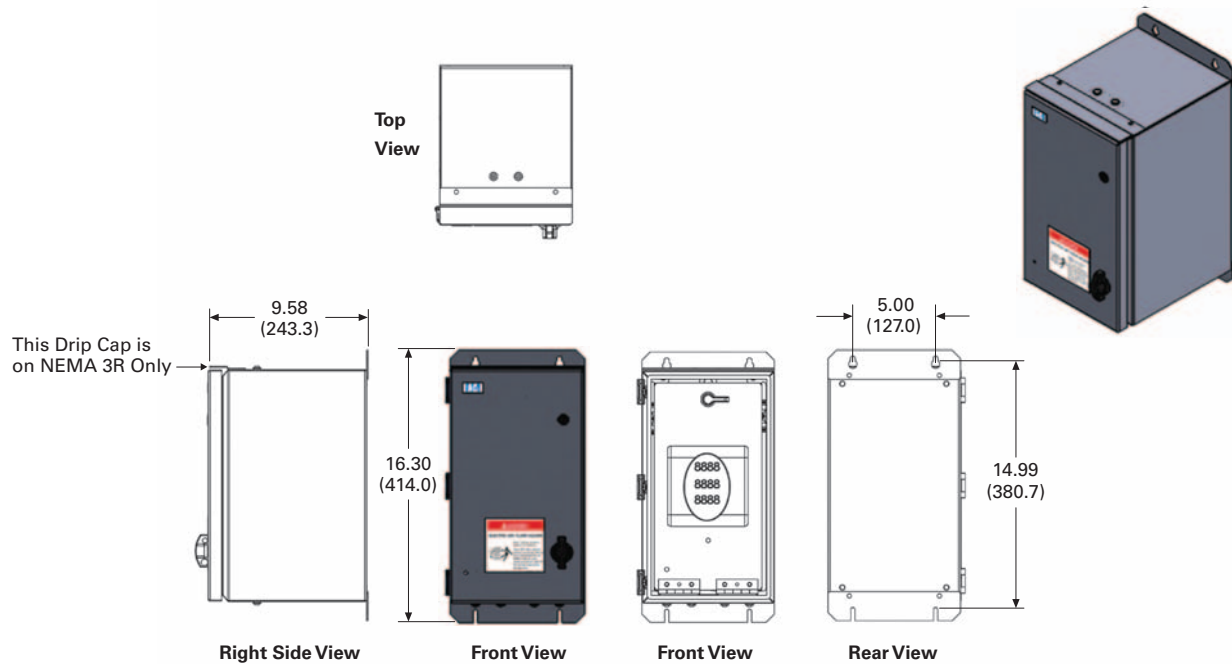

NEMA 3R/4X Multi Unit Enclosure

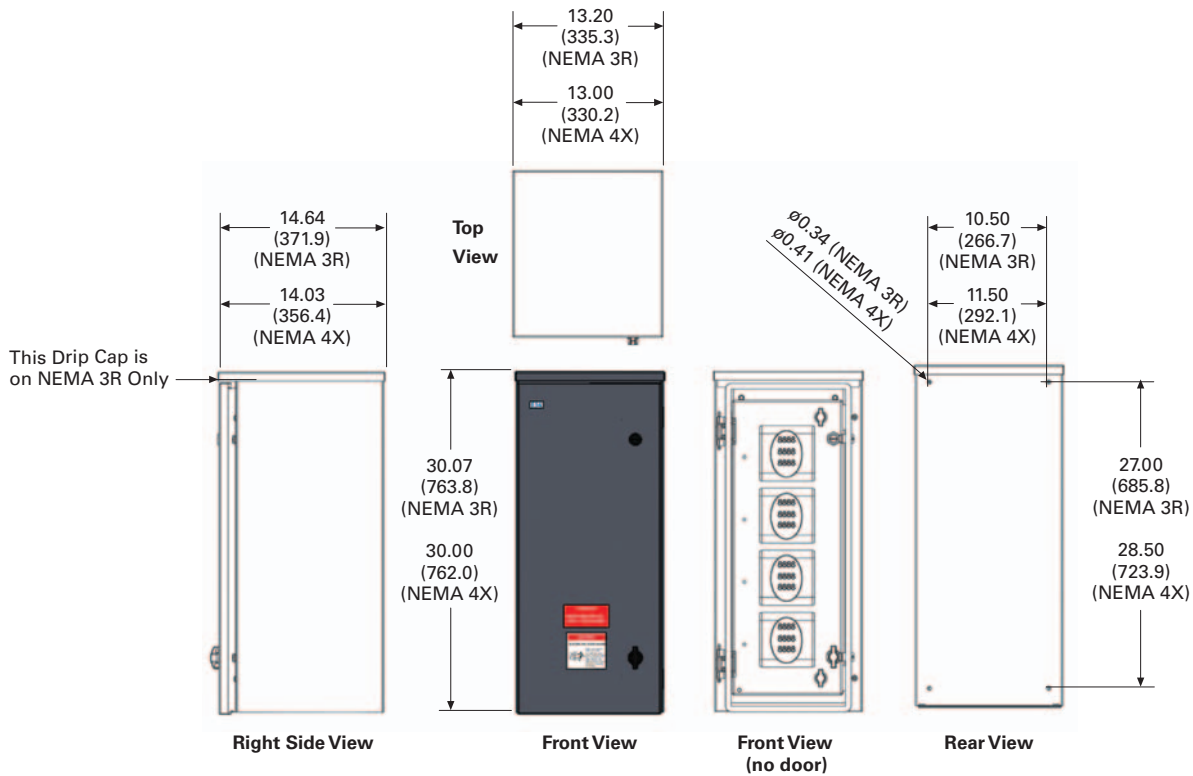

9.3

Metering Devices, Protective Relays, Software and Connectivity

Metering Devices

Approximate Dimensions in Inches (mm)

NEMA 3R PXM 4000/6000/8000 Unit Enclosure

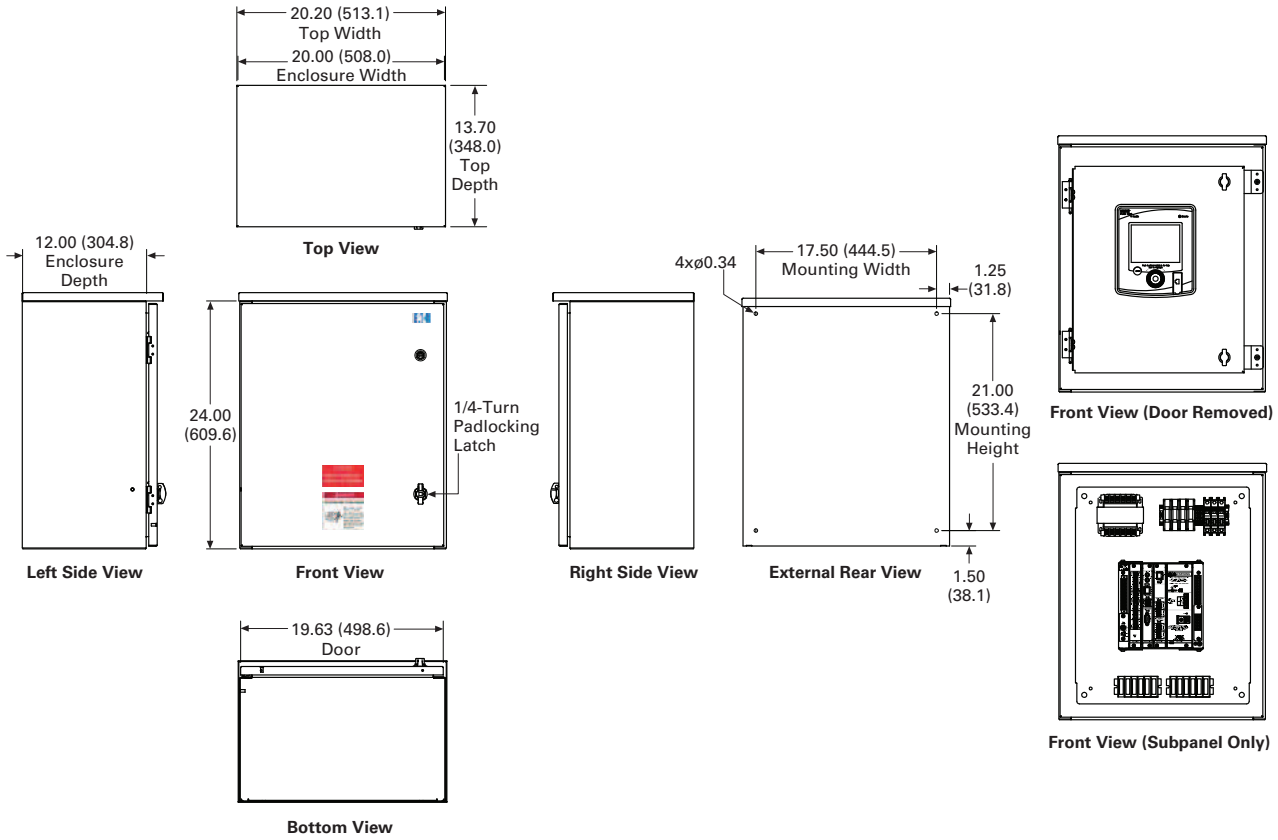

Approximate Dimensions in Inches (mm)

NEMA 4X PXM 4000/6000/8000 Unit Enclosure

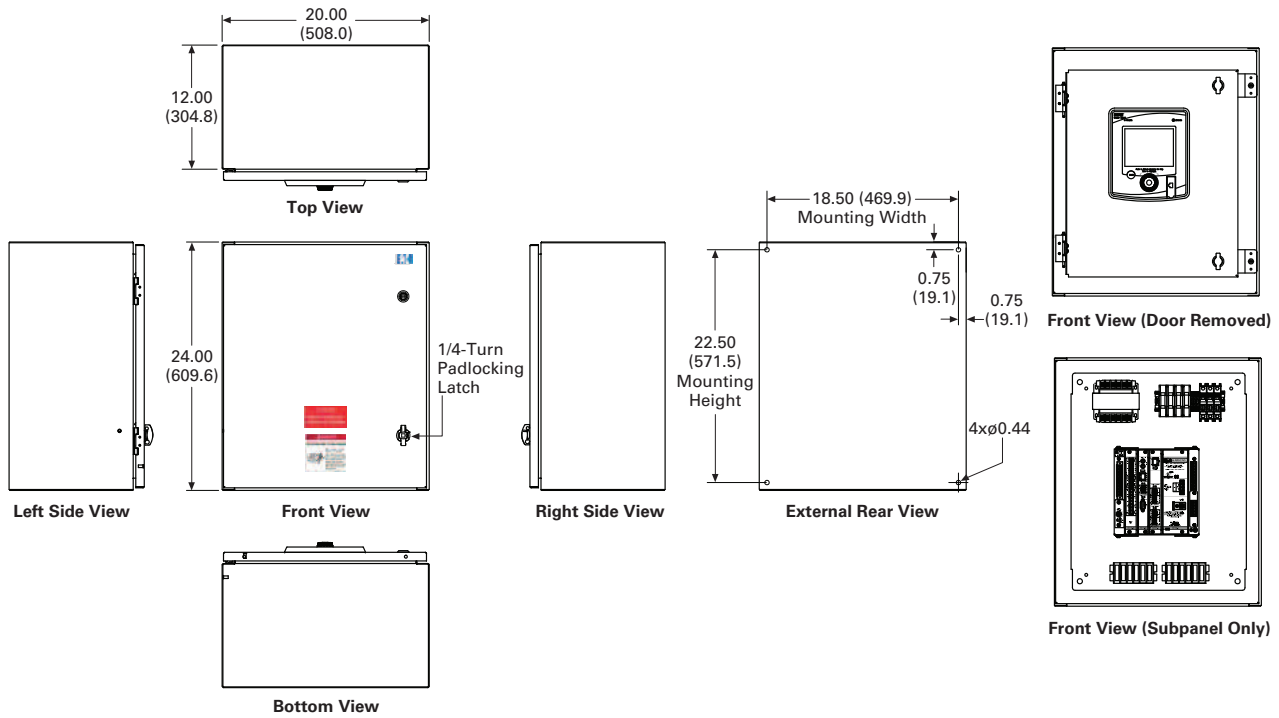

9.3

Metering Devices, Protective Relays, Software and Connectivity

Metering Devices

Approximate Dimensions in Inches (mm)

NEMA 3R PXMP Multi Unit Enclosure

9

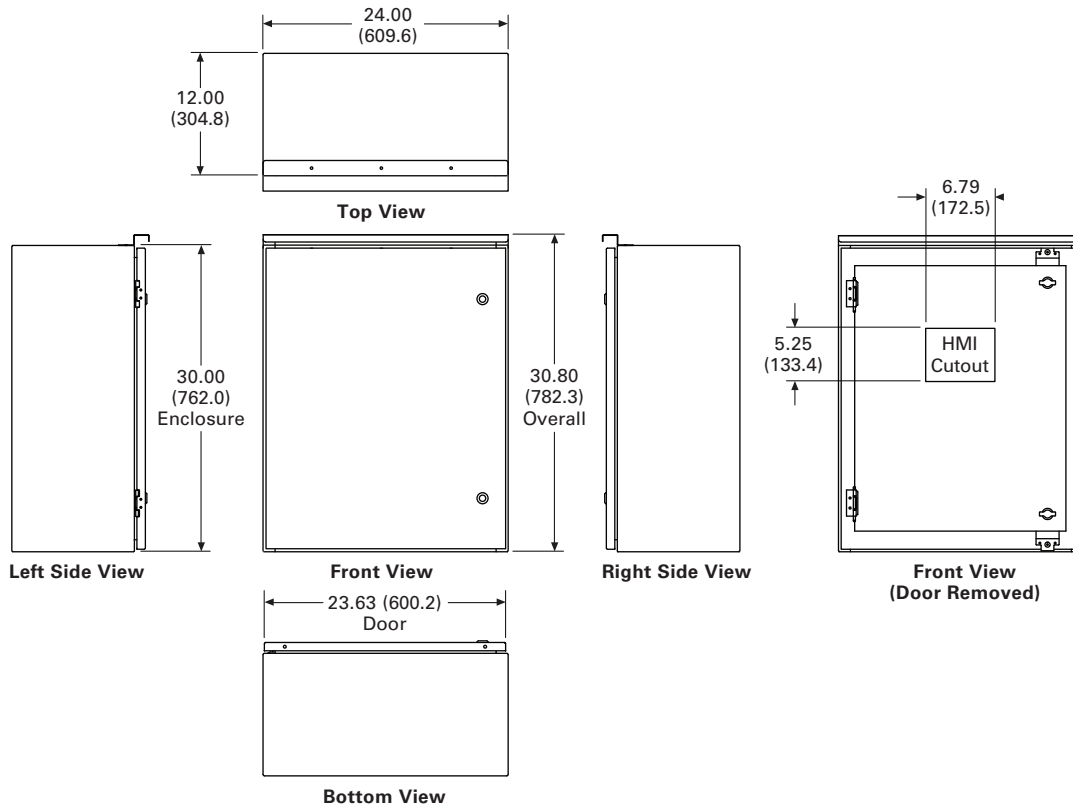

Approximate Dimensions in Inches (mm)

NEMA 4X PXMP Multi Unit Enclosure

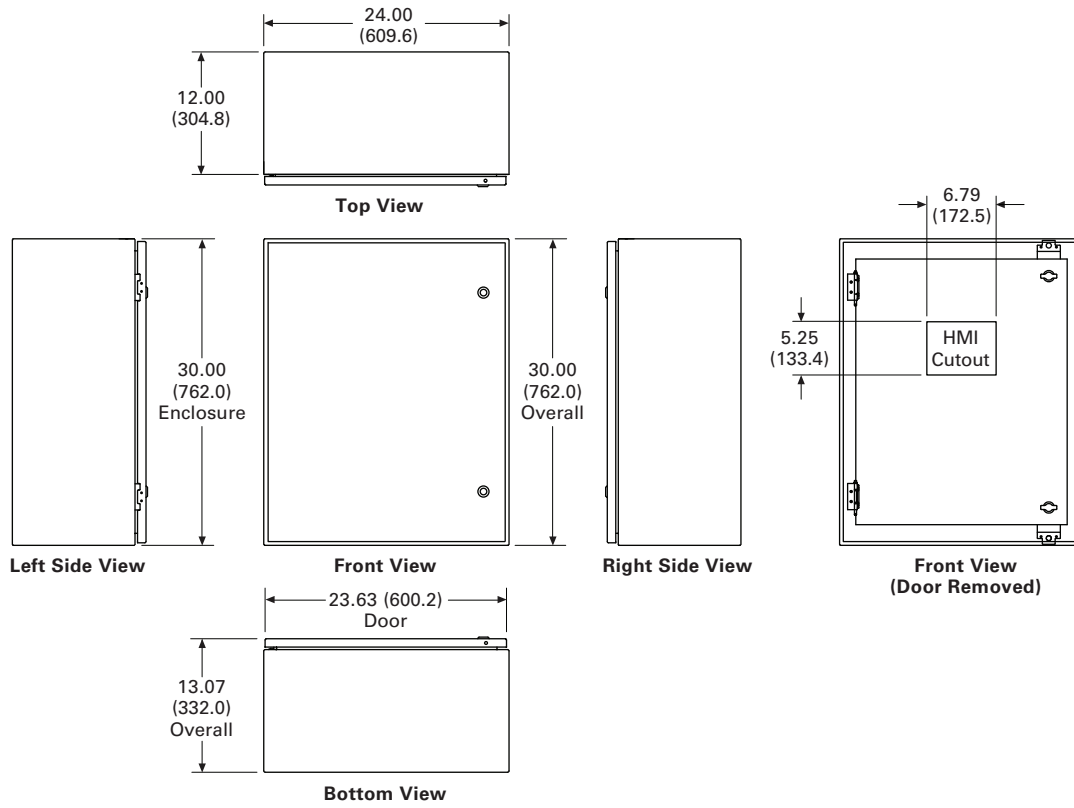

Contents

<i>Description</i>	<i>Page</i>
Product Selection Guide	
FP-6000 Feeder Protection	V3-T9-162
FP-5000 Feeder Protection	V3-T9-172
FP-4000 Feeder Protection	V3-T9-180
MP-3000 Motor Protection	V3-T9-188
MP-4000 Motor Protection	V3-T9-198
MD-3000 Motor/Generator Differential Relay	V3-T9-204
Digitrip 3000	V3-T9-207
VR-300 Multifunctional Voltage Relay	V3-T9-217
DP-300 Current Differential Protection Relay	V3-T9-221
EDR-3000 Feeder Protection	V3-T9-226
ETR-4000 Transformer Protection Relay	V3-T9-237
Ground Fault Relay	V3-T9-250
Universal RTD Module	V3-T9-254
IQ 125 Volt DC Power Supply	V3-T9-258

Product Selection Guide

Protective Relay Selection Chart

Protection Functions

Description Section Page Number	IEEE Device Number	Feeder Protection		Motor Protection					Voltage Protection	Transformer Protection	
		DT-3000 V3-T9-207	EDR-3000 V3-T9-226	FP-4000 V3-T9-180	FP-5000 V3-T9-172	FP-6000 V3-T9-162	MP-3000 V3-T9-188	MP-4000 V3-T9-198	MD-3000 V3-T9-204	VR-300 V3-T9-217	DP-300 V3-T9-221
Phase inst. OC	50	■	■	■	■	■	■	■			■
Phase TOC	51	■	■	■	■	■	■	■			■
Ground inst. OC (measured)	50G	■	■	■	■	■					■
Ground TOC (measured)	51G	■	■	■	■	■	■	■			■
Phase directional control ①	67				■	■					
Ground directional control ②	67N				■	■					
Phase voltage restrained OC	51VR				■	■					
No. of curves (ANSI/IEC/thermal)		11	11	10	10	10					11
Zone interlocking		■	■	■	■	■					■
Thermal overload	49					■	■	■			■
Locked rotor	49S/51					■	■	■			
Jam/stall	51R					■	■	■			
Undervoltage	27			■	■	■		■		■	
Current unbalance	46			■	■	■	■	■			
Negative sequence voltage	47			■	■	■		■		■	
Power factor	55			■	■	■		■			
Overvoltage	59			■	■	■		■		■	
Frequency (over/under)	81			■	■	■		■		■	
Forward/reverse VARs	32V					■				■	

Notes

- ① The 50 and 51 protective functions can be controlled for reverse, forward or both directional protection.
- ② The 50N, 51N, 50G and 51G protective functions can be controlled for reverse, forward or both directional protection.

Protection Functions, continued

Description Section Page Number	IEEE Device Number	Feeder Protection					Motor Protection			Voltage Protection	Transformer Protection	
		DT-3000	EDR-3000	FP-4000	FP-5000	FP-6000	MP-3000	MP-4000	MD-3000	VR-300	DP-300	ETR-4000
		V3-T9-207	V3-T9-226	V3-T9-180	V3-T9-172	V3-T9-162	V3-T9-188	V3-T9-198	V3-T9-204	V3-T9-217	V3-T9-221	V3-T9-237
Differential	87	■ ^①		■ ^①	■ ^①	■ ^①			■ ^②		■ ^③	■ ^④
Forward/reverse power	32				■	■		■				
Sync check	25				■	■			■			
Reclosing	79					■						
Loss of potential block	LOP				■	■						
Cold load pickup					■	■						■
Breaker failure	50BF		■	■	■	■						■
2 nd harmonic restrain											■	■
5 th harmonic restrain											■	■
4 th harmonic restrain												■
87 GD ground differential												■

Control Functions

Description Section Page Number	IEEE Device Number	Feeder Protection					Motor Protection			Voltage Protection	Transformer Protection	
		DT-3000	EDR-3000	FP-4000	FP-5000	FP-6000	MP-3000	MP-4000	MD-3000	VR-300	DP-300	ETR-4000
		V3-T9-207	V3-T9-226	V3-T9-180	V3-T9-172	V3-T9-162	V3-T9-188	V3-T9-198	V3-T9-204	V3-T9-217	V3-T9-221	V3-T9-237
Remote open/close		■	■	■	■	■	(Trip only)	■	■			■
Programmable I/O		■	■	■	■	■	■	■	■			■
Programmable logic control				■	■	■						
Multiple settings groups			4	4	4	4						4
Number of starts limit							■	■				
Starts per hour							■	■				
Time between starts							■	■				
Emergency override							■	■				
Reduced voltage starting							■	■				
Trip lock out		■	■	■	■	■	■	■				■

Notes

- ① 87B using zone selective interlocking.
- ② 87M or 87G (motor or generator differential).
- ③ 87M, 87T or 87G (motor, transformer or generator differential).
- ④ 87T (transformer differential).

Metering Functions

Description Section Page Number	IEEE Device Number	Feeder Protection					Motor Protection				Voltage Protection	Transformer Protection	
		DT-3000	EDR-3000	FP-4000	FP-5000	FP-6000	MP-3000	MP-4000	MD-3000	VR-300	DP-300	ETR-4000	
		V3-T9-207	V3-T9-226	V3-T9-180	V3-T9-172	V3-T9-162	V3-T9-188	V3-T9-198	V3-T9-204	V3-T9-217	V3-T9-221	V3-T9-237	
Amperes		■	■	■	■	■	■	■	■		■ ^①	■	
Ampere demand		■	■	■	■	■		■				■	
Volts				■	■	■		■		■			
Phase angle (current and voltage)				■	■	■		■				Current only	
Positive, negative and zero sequence			■	■	■	■		■				■	
Watts				■	■	■		■					
Watt Demand				■	■	■		■					
Watt-hour				■	■	■		■					
VARs				■	■	■		■					
VAR demand				■	■	■		■					
VAR-hour				■	■	■		■					
VA				■	■	■		■					
VA Demand				■	■	■		■					
VA-hour				■	■	■		■					
Frequency				■	■	■		■		■			
Trending (load profile)				■	■	■							
Minimum/maximum recording			■	■	■	■	Max. only	■				■	

Monitoring Functions

Description Section Page Number	IEEE Device Number	Feeder Protection					Motor Protection				Voltage Protection	Transformer Protection	
		DT-3000	EDR-3000	FP-4000	FP-5000	FP-6000	MP-3000	MP-4000	MD-3000	VR-300	DP-300	ETR-4000	
		V3-T9-207	V3-T9-226	V3-T9-180	V3-T9-172	V3-T9-162	V3-T9-188	V3-T9-198	V3-T9-204	V3-T9-217	V3-T9-221	V3-T9-237	
Trip circuit monitor			■	■	■	■						■	
Breaker wear			■	■	■	■						■	
Failure to close			■	■	■	■						■	
Oscillography			■	■	■	■						■	
Sequence of events			■	■	■	■	■	■				■	
Trip target data		■	■	■	■	■	■	■	■			■	
Clock			■	■	■	■	■	■				■	
Number of starts						■	■	■					
Acceleration time						■	■	■					
RTD temperature						■	■	■				■	
Hottest RTD						■	■	■				■	

Note

① Differential and restrain current only.

Communications

Description	IEEE Device Number	Feeder Protection					Motor Protection			Voltage Protection	Transformer Protection	
		DT-3000 V3-T9-207	EDR-3000 V3-T9-226	FP-4000 V3-T9-180	FP-5000 V3-T9-172	FP-6000 V3-T9-162	MP-3000 V3-T9-204	MP-4000 V3-T9-198	MD-3000 V3-T9-204	VR-300 V3-T9-217	DP-300 V3-T9-221	ETR-4000 V3-T9-237
Local human machine interface		■	■	■	■	■	■	■	■			■
Remote communication port												
RS-232			■	■	■	■						■
RS-485			■	■	■	■						■
Ethernet copper			■									■
Frequency shift key		■		■	■	■	Optional					
Addressable Protocols		■		■	■	■	■	■				
INCOM		■		■	■	■	■	■				
Modbus-RTU		■	■	■	■	■	■	■				■
Modbus-TCP			■									■

Construction

Description	IEEE Device Number	Feeder Protection					Motor Protection			Voltage Protection	Transformer Protection	
		DT-3000 V3-T9-207	EDR-3000 V3-T9-226	FP-4000 V3-T9-180	FP-5000 V3-T9-172	FP-6000 V3-T9-162	MP-3000 V3-T9-188	MP-4000 V3-T9-198	MD-3000 V3-T9-204	VR-300 V3-T9-217	DP-300 V3-T9-221	ETR-4000 V3-T9-237
Panel mount case		■	■	■	■	■	■	■	■	■	■	■
Drawout		Optional	Removable terminals	■	Optional	Optional	Optional	Optional	Optional			Removable terminals
Operating temperature range		-30°-55°C	-40°-60°C	-40°-60°C	-40°-60°C	-40°-60°C	-20°-60°C	-20°-60°C	-30°-55°C	-20°-70°C	20°-70°C	-40°-60°C
Power supply options		120-240 Vac	19-300 Vdc	48-125 Vac/Vdc	48-125 Vac/Vdc	48-125 Vac/Vdc	120-240 Vac	120-240 Vac	120-240 Vac	40-250 Vac	40-250 Vac	19-300 Vdc
		24-250 Vdc	40-250 Vac	100-240 Vac/Vdc	100-240 Vac/Vdc	100-240 Vac/Vdc			24-250 Vdc	90-250 Vdc	90-250 Vdc	40-250 Vac
AC current inputs		■	■	■	■	■	■	■	■	■	■	■
AC voltage inputs				■	■	■		■		■		
Wye PTs				■	■	■		■		■		
Delta/open delta PTs				■	■	■		■		■		
Binary inputs		■	■	■	■	■	■	■	■	■	■	■
Alarm outputs		2 Form C	1 Form C	2 Form C	2 Form C	2 Form C	3	■	2 Form C	1 Form C	1 NO	1 Form C
Trip outputs		2	3	5	5	5	■	■	■	■	■	■
Analog outputs							■	■				■
Local display		■	■	■	■	■	■	■	■	■	■	■
LEDs (local targets)		■	■	■	■	■	■	■	■	■	■	■

Standards

Description	IEEE Device Number	Feeder Protection					Motor Protection			Voltage Protection	Transformer Protection	
		DT-3000 V3-T9-207	EDR-3000 V3-T9-226	FP-4000 V3-T9-180	FP-5000 V3-T9-172	FP-6000 V3-T9-162	MP-3000 V3-T9-188	MP-4000 V3-T9-198	MD-3000 V3-T9-204	VR-300 V3-T9-217	DP-300 V3-T9-221	ETR-4000 V3-T9-237
ANSI		■	■	■	■	■	■	■	■	■	■	■
IEC		■	■	■	■	■	■	■	■	■	■	■
UL		■	■	■	■	■	■	■	■	■	■	■
CE		DT-3030 only	■	■	■	■						■
CSA		■	■	■	■	■	■	■	■			■

Feeder Protection FP-6000



FP-6000 Feeder Protection

Product Description

- Microprocessor-based protection with monitoring and control for medium voltage main and feeder applications
- Current, voltage, frequency and power protection for electric power distribution systems
- Complete metering of voltage, currents, power, energy, minimum/maximum and demand functions
- Programmable logic control functions for main-tie-main and main-main transfer schemes
- Trip logs, event logs and waveform capture for better fault analysis and system restoration
- Data Logger to provide energy usage profiles for better planning, utilization and energy usage
- Compact, drawout case design or fixed case design
- Meets ANSI and UL

Application Description

Eaton's FP-6000 Protection Relay provides complete three-phase and ground overcurrent, voltage, frequency and power protection plus metering in a single, compact drawout case. It may be used as a reclosing relay; primary protection on feeders; mains and tie circuit breaker applications; or as backup protection for transformers, high voltage lines and differential protection.

The FP-6000 takes full advantage of its microprocessor technology, providing the user new freedom and a wealth of data-gathering features. The relay performs self-checking of all major hardware and firmware protection elements to ensure their operation in the event of a system or component electrical failure or fault. Protection functions are well suited for main and distribution feeder circuit applications. Programmable logic control functions make the FP-6000 relay ideally suited for main-tie-main and main 1/main two transfer schemes.

Contents

Description

	<i>Page</i>
Product Selection Guide	V3-T9-158
FP-6000 Feeder Protection	
Features, Benefits and Functions	V3-T9-163
Standards and Certifications	V3-T9-164
Catalog Number Selection	V3-T9-165
Product Selection	V3-T9-165
Technical Data and Specifications	V3-T9-166
Dimensions	V3-T9-171
FP-5000 Feeder Protection	V3-T9-172
FP-4000 Feeder Protection	V3-T9-180
MP-3000 Motor Protection	V3-T9-188
MP-4000 Motor Protection	V3-T9-198
MD-3000 Motor/Generator Differential Relay	V3-T9-204
Digitrip 3000	V3-T9-207
VR-300 Multifunctional Voltage Relay	V3-T9-217
DP-300 Current Differential Protection Relay	V3-T9-221
EDR-3000 Feeder Protection	V3-T9-226
ETR-4000 Transformer Protection Relay	V3-T9-237
Ground Fault Relay	V3-T9-250
Universal RTD Module	V3-T9-254
IQ 125 Volt DC Power Supply	V3-T9-258

The FP-6000 is the only relay in its class that offers a flexible, yet simple reclosing control. Its compact design makes it ideal for polemounted recloser controls. The zone interlocking feature can be utilized for bus protection instead of an expensive and complicated bus differential (87B) scheme. The FP-6000 works directly with the FP-5000, FP-4000, Digitrip® 3000 and Digitrip MV relays. The breaker failure protection provides faster remote backup clearing times for stuck breaker operation. In addition to the breaker failure protection, the FP-6000 can be programmed to detect residual current when the breaker is open to detect flashover conditions. The FP-6000 provides trip circuit monitoring and alarming features. It continually monitors the trip circuit for continuity and readiness to trip. Open and close pushbuttons are conveniently located on the front of the relay for local breaker operation.

When an electrical fault or disturbance occurs, the FP-6000 begins to store the following in non-volatile memory:

- Voltage and current sampled data
- Calculated values
- Status of internal protection functions, logic, contact inputs and outputs

Retrieval and viewing of the data is easy, aiding in the quick analysis and restoration of your electric power system.

When the FP-6000 isn't responding to disturbances in the power system, it's providing valuable metering information at the relay and remotely. It provides energy usage and demand reading, and can alarm when usage reaches a set value. Power factor measurements can be used for cap bank switching to control kVAR demand. Onboard data trending can provide load profiles for up to 40 days.

Features, Benefits and Functions

- Complete protection, metering and control in a single compact case to reduce panel space, wiring and costs
- Flexible current, voltage and frequency protection and programmability to cover a broad range of applications while simplifying relay ordering and reducing inventory
- Integral test function reduces maintenance time and expense
- Relay self-diagnostics and reporting improves uptime and troubleshooting
- Breaker trip circuit monitoring improves the reliability of the breaker operation
- Programmable LEDs and logic control features that can replace and eliminate external auxiliary relays, timers, light and wiring
- Zone selective interlocking improves coordination and tripping times and saves money compared to a traditional bus differential scheme
- Trip and event recording in non-volatile memory provides detailed information for analysis and system restoration
- 256 cycles of waveform capture aids in post fault analysis (viewable using PowerNet and NPWAVEFORM component)
- Front RS-232 port and PowerPort software provides local computer access and a user-friendly, Windows-based interface for relay settings, and configuration and data retrieval
- Drawout case design for quick and easy relay removal and replacement
- Breaker open/close control from relay faceplate or remotely via communications
- Remote communications to Eaton PowerNet monitoring system or PC

- Free PowerPort utility software for local PC interface to the FP-6000 for relay settings, monitoring and control

The protection functions are listed below and shown on **Page V3-T9-168**.

The FP-6000 provides phase overcurrent (forward, reverse or both):

- Two-stage instantaneous with timers (50P-1 and 50P-2)
- Inverse time overcurrent (51P)
- Directional control (67P)
- 10 standard curves
- Instantaneous or time delay reset
- Voltage restrained inverse time overcurrent (51P2)

The FP-6000 provides two ground overcurrent elements, one measured (IX) and one calculated (IR):

- Independent measured ground or neutral directional overcurrent elements:
 - Two-stage instantaneous with timers (50X-1 and 50X-2)
 - Inverse time overcurrent (51X)
 - Ground directional polarizing (67N) -3vo and negative sequence
 - 10 standard curves
 - Instantaneous or time delay reset

- Independent calculated ground or neutral directional overcurrent elements:
 - Two-stage instantaneous with timers (50R-1 and 50R-2)
 - Inverse time overcurrent (51R)
 - Ground directional polarizing (67N) -3vo, I pol and negative sequence
 - 10 standard curves
 - Instantaneous or time delay reset

The FP-6000 also provides the following protective features:

- Breaker failure (50BF)
- Phase unbalance negative sequence overcurrent (46-1, 46-2)
- Phase voltage unbalance and sequence protection (47-1, 47-2)
- Main 3-phase under/overvoltage (27M-1, 27M-2, 59M-1, 59M-2)
- Under/overfrequency (81U-1, 81U-2, 81O-1, 81O-2)
- Auxiliary single-phase under/overvoltage (27A-1, 27A-2, 59A-1, 59A-2)
- Neutral voltage (59N-1, 59N-2)
- Apparent and displacement power factor (55A, 55D)
- Forward/reverse power protection (32-1, 32-2, 32-3)
- Forward/reverse VAR protection (32V-1, 32V-2, 32V-3)
- Thermal Protection (49DT, 49MT, 49DA, 49MA)
- Sync check (25)
- Zone interlocking for bus protection (87B). The FP-6000 feeder relay includes a zone selective interlocking feature that can be used with other Eaton devices like the Digitrip 3000 overcurrent relay

The FP-6000 provides the following metering functions:

- Amperes (rms, phasor and sequence)
- Amperes demand and peak demand.
- Volts (rms, phasor and sequence).
- VA and VA demand
- Watts and kW demand and peak demand.
- Forward/reverse/net kWh
- Vars and kVAR demand and peak demand
- Lead/lag/net kVARh
- Power factor
- Frequency
- Voltage and current %THD and magnitude THD
- RTD

- Minimum/maximum recording with date/time stamp
- Trending (load profile over time)

The FP-6000 provides the following monitoring and data recording functions that enhance the security of the protection system and provides useful information for scheduling maintenance:

- Trip circuit monitoring
- Breaker wear (accumulated interrupted current)
- Waveform capture (256 cycles total, up to 16 events)
- Fault data logs (up to 16 events).
- Sequence of events report (up to 100 events)
- Clock (1ms stamping)

The FP-6000 provides standard control functions plus userconfigurable custom control capabilities. This logic can be used for applications such as main-tie-main transfer schemes.

- Remote open/close.
- Optional local open/close
- Programmable I/O
- Programmable logic gates and timers
- Multiple setting groups (up to four)
- Bus transfer logic
- Cold load pickup
- Loss of potential (PT blown fuses)
- Autoreclose Function (79)
- Auto Zone Coordination

The FP-6000 supports the following communication options:

- Local HMI
- Password protected
- Addressable
- Front RS-232 port
- Rear RS-485 port
- Rear FSK port
- Protocols:
 - INCOM
 - Modbus RTU

Communication Software

Eaton provides two types of communication software. The first is PowerPort. It runs on a PC or laptop for easy access to a single relay to change set points or configuration and to view metered values and stored data. PowerPort is free and can be downloaded from the Eaton Web site at the following URL: www.eaton.com; search for "PowerPort."

The second package is PowerNet. PowerNet is a power management software package that is designed for continuous, remote monitoring of many devices. It provides all the functionality of PowerPort plus additional functions such as billing, trending and graphics. Contact your local Eaton representative for more information on PowerNet software.

Standards and Certifications

Compliance

- UL recognized, File # E154862 (FP6200-00 5A CT model only)
- UL 1053 (1994) recognized
- ANSI C37.90 (1989)
- EN 55011 (1991)
- EN 61000-6-2 (1999)



Emission Tests

- EN 55011 (1991): Group 1 Class A (CISPR-11, Class A)
- FCC 47 CFR Chapter 1: Part 15 Subpart b Class A

Immunity Tests

- ANSI C37.90.1 (1989): surge withstand capability
- ANSI C37.90.2 (1995): EMI immunity to 35 V/m
- EN 61000-4-2 (1995): ESD Rating of 8 kV
- EN 61000-4-3 (1997): radiated EM field at 10 V/m
- EN 61000-4-4 (1995): fast transient burst at 2 kV
- EN 61000-4-5 (1995): surge immunity test
- EN 61000-4-6 (1996): conducted RF at 10 V/m
- EN 61000-4-8: power frequency magnetic field immunity
- EN 61000-4-11 (1994): voltage dips and variations

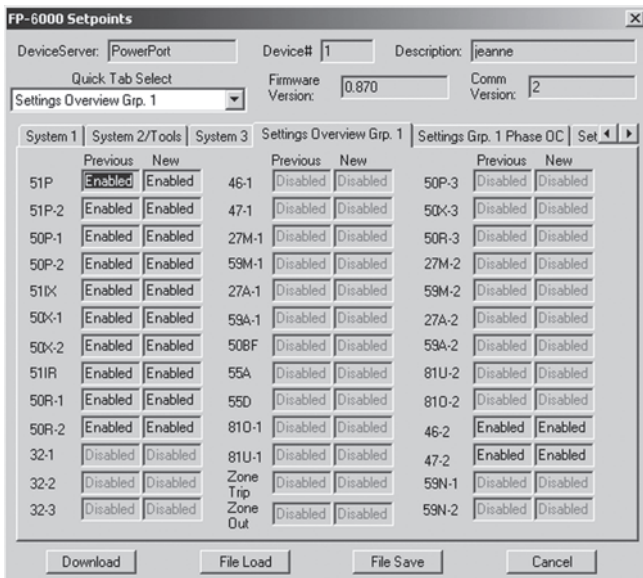

PowerPort and PowerNet Protection Overview Screen

Reference Information

Description	Style Number	Pub Number
Instruction booklet	66A2347H01	IB02602004E

Catalog Number Selection

FP-6000 Feeder Protection

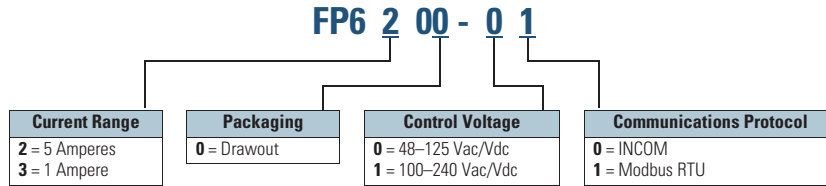

Product Selection

FP-6000



FP-6000 Catalog Numbers

Option Description	Style Number	Catalog Number
5A CT 48–125 Vdc, 100–120 Vac power supply Standard communication board	66D2167G01	FP6200-00
1A CT 48–125 Vdc, 100–120 Vac power supply Standard communication board	66D2167G02	FP6300-00
5A CT 100–250 Vdc, 100–240 Vac power supply Standard communication board	66D2167G04	FP6200-10
1A CT 100–250 Vdc, 100–240 Vac power supply Standard communication board	66D2167G05	FP6300-10
5A CT 100–250 Vdc, 100–240 Vac power supply Modbus communication board	66D2167G06	FP6200-11
1A CT 100–250 Vdc, 100–240 Vac power supply Modbus communication board	66D2167G07	FP6300-11
5A CT 48–125 Vdc, 100–120 Vac power supply Modbus communication board	66D2167G08	FP6200-01
1A CT 48–125 Vdc, 100–120 Vac power supply Modbus communication board	66D2167G09	FP6300-01

Technical Data and Specifications

Protective Functions

Phase and Ground Overcurrent Protection

- Inverse characteristics: Mod, Very, Extremely, IECA, IECB, IECC, It, I²t, I⁴t, Flat
- TOC (51) pickup range: 0.02 to 4.0 per unit in 0.01 steps
- Time multipliers: 0.05 to 10.0 in 0.01 steps
- IOC (50) pickup range: 0.1 to 20.0 per unit in 0.01 steps
- Pickup accuracy: $\pm 1\%$ (at 0.1 to 2 per unit)
- Time delay: 0 to 9999 cycles in 1 cycle steps
- Time accuracy: $\pm 3\%$ or ± 30 ms
- Directional (67, 67N, 67G): forward, reverse or both

Voltage Unbalance (47)

- Threshold (minimum voltage) 1 to 100 volts in 1 volt steps
- % V₂/V₁: 2 to 40% in 1% steps
- Time delay: 0 to 9999 cycles in 1 cycle steps

Current Unbalance (46)

- Threshold (minimum current) 0.1 to 20.0 per unit in 0.01 steps
- % I₂/I₁: 2 to 40% in 1% steps
- Time delay: 0 to 9999 cycles in 1 cycle steps

Under/Overtension Protection (27/59)

- Pickup range: 10 to 150 volts in 1 volt steps
- Time delay: 0 to 9999 cycles in 1 cycle steps

Neutral Voltage Protection (59N)

- Source: calculated, measure
- Criterion: phasor, rms
- Pickup range: 5 to 250 volts in 1 volt steps
- Time delay: 0 to 9999 cycles in 1 cycle steps

Under/Over Frequency Protection (81U/O)

- Pickup range: 45 to 65 Hz in 0.01 Hz steps
- Time delay: 0 to 9999 cycles in 1 cycle steps

Breaker Failure Protection (50BF)

- Pickup range: 0.02 to 5.0 per unit in 0.01 steps
- Time delay: 0 to 9999 cycles in 1 cycle steps

Power Factor (55)

- Trigger/reset threshold: -0.5 to 1 lag; 0.5 to 0.99 lead in 0.01 steps
- Time delay: 0 to 1000 seconds in 1 second steps

Power Protection (32)

- Direction: forward/reverse
- Criterion: over/under
- Pickup range: 0.02 to 4 pu

Note: 1 pu = 3 x CT secondary rating x VT secondary rating for wye; the square root of 3 x VT secondary rating x CT secondary rating for open delta.

- Pickup accuracy: $\pm 1.0\%$
- Trip time accuracy: 0 to 2 cycles or 0.1%, whichever is greater

VAR Protection (32V)

- Direction: forward/reverse
- Criterion: over/under
- Pickup range: 0.02 to 4 pu

Note: 1 pu = 3 x CT secondary rating x VT secondary rating for wye; the square root of 3 x VT secondary rating x CT secondary rating for open delta.

- Pickup accuracy: $\pm 1.0\%$
- Trip time accuracy: 0 to 2 cycles or 0.1%, whichever is greater

Thermal Protection (49)

- Pickup range: 0°F to 390°F or 0°C to 199°C
- Time delay: 0.1 to 3600 seg

Sync Check (25)

- Phase angle: 1 to 60°
- Slip frequency: 0.1 to 2 Hz
- Voltage differential: 1 to 100 volts
- Breaker close time: 0 to 9999 cycles

Discrete Inputs

- Number of contact inputs: 8
- Rating: 48 Vdc wetting voltage provided with internal ground only

Output Contacts

- Number of output contacts: Five Form A and two Form C

Rating of Output Contacts

- Momentary:
 - Make 30A AC/DC for 0.25 seconds
 - Break 0.25A at 250 Vdc (resistive)
 - Break 5A at 120/240 Vac
- Continuous:
 - 5A at 120/240 Vac
 - 5A at 30 Vdc

Logic and Control Functions

- Six programmable logic gates for AND, OR, NAND, NOR operation
- Two latching (flip/flop) gates
- Six timer gates provide on/off delays

INCOM Communications

- Baud rate: 9600 fixed
- Maximum distance: 10,000 feet (3,048 m)
- Protocol: INCOM

RS-232 Communications, Front Panel

- Baud rate: 38.4K, 19.2K, 9.6K
- Connector standard 9-pin subminiature, three-wire
- Protocol: INCOM

RS-485 Communications, Rear Panel

- Baud rate: 19.2K, 9.6K
- Protocol: Modbus RTU

Environmental Ratings

- Operating temperature: -40°F to $+140^{\circ}\text{F}$ (-40°C to $+60^{\circ}\text{C}$)
- Storage temperature: -40°F to $+185^{\circ}\text{F}$ (-40°C to $+85^{\circ}\text{C}$)
- Humidity: 5% to 95% relative humidity (noncondensing)
- Altitude: 0 to 6,350 feet (0 to 1,935 m) above Mean Sea Level

Control Power

- Control voltage:
 - 48–125 Vdc/100–120 Vac
 - 100–250 Vdc/100–240 Vac
- Operating voltage:
 - 38–150 Vdc/55–132 Vac
 - 80–308 Vdc/55–264 Vac
- Interruption ride-through time:
 - 83 ms at 120V, 60 Hz AC
 - 250 ms at 110 Vdc/
300 ms at Vac
- Power consumption:
 - 20 VA maximum
 - 22 VA maximum

Current Inputs

- CT rating:
 - 2 x In at 5 amperes continuous
 - 3 x In at 1 ampere continuous
 - 80 x In at 5 amperes for 1 second
 - 100 x In at 1 ampere for 1 second
- CT burdens:
 - < 0.25 VA at 5A (nominal)
 - < 0.05 VA at 1A (nominal)

Voltage Transformer Inputs

- Nominal: 0–120 Vac line to common
- Operating range: 0–144 Vac (+20%) line to common
- Burden: 1 mega ohm input impedance

Metering Accuracy

- Input signal frequency necessary for accurate operation:
 - 60 Hz Nominal, 57–63 Hz (5%)
 - 50 Hz Nominal, 47–53 Hz (5%)
- Frequency measurement accuracy:
 - ±0.02 Hz
- Clock accuracy:
 - Free running ±1 minute/month at 77°F (25°C)
 - Automatically updated by PowerNet host when present

FP-6000 Specifications

Principal Parameters	Range	Accuracy
Current (amperes) Ia, Ib, Ic, Ir, Ix	0.02 to 20 per unit	at < 2 x CT rating: ±0.5% of CT rating at > 2 x CT rating: ±0.5% of reading
Sequence currents	0.02 to 20 per unit	±1% of nominal
Main voltage	0 to 160V	±0.5% of nominal ±0.2V
Sequence voltages	0 to 160V	±1% of nominal
Auxiliary voltage	0 to 250V	±1% of nominal
Phase angle for I and V	0 to 360°	±1° at nominal voltage
System frequency	45 to 65 Hz	±0.02 Hz
Ampere demand	0.02 to 20 per Unit	±0.5%
Watt demand	0 to 4000 MW	±1.0% FS for PF = unity ① ±1.5% FS for PF = -0.5 to 0.5 ①
Watts	0 to 4000 MW	—
Watt-hours	0 to 999.999 MWh	—
VAR demand	0 to 4000 MVAR	±1.5% FS for PF = -0.5 to 0.5 ①
VARs	0 to 4000 MVAR	—
VAR-hours	0 to 999.999 Mvarh	—
VA demand	0 to 4000 MVA	±1% FS ①
VA	0 to 4000 MVA	—
VA-hours	0 to 999.999 MVAh	—
Apparent power factor	-1 to +1	±0.02 for load currents above 20% rated
Displacement power factor	-1 to +1	±0.02 for load currents above 20% rated
Total harmonic distortion	0 to 9999	±1%
Other metering accuracy		±1%

Note

① FS (Full Scale) = 3 x CT Rating x Nominal L-N Voltage.

Wiring Diagrams

FP-6000 One-Line Drawing

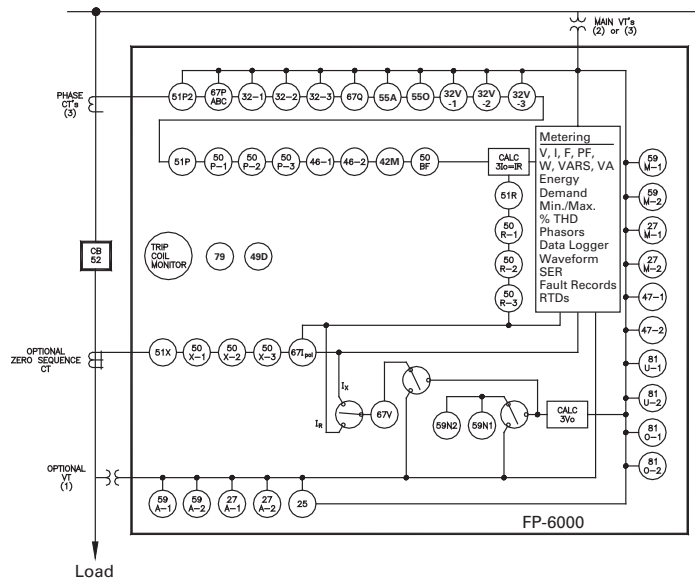

FP-6000 Rear View and Terminal Designations

TB1		TB2	
101	Power Supply Input (+)	201	C In 1
102	Power Supply Input (-)	202	C In 2
103	RLY Healthy Com.	203	C In 3
104	RLY Healthy N.O.	204	C In 4
105	RLY Healthy N.C.	205	C In Source 1
106	Alarm Com.	206	C In 5
107	Alarm N.O.	207	C In 6
108	Alarm N.C.	208	C In 7
109	RLY 5 Com.	209	C In 8
110	RLY 5 N.O.	210	C In Source 2
111	RLY 4 Com.	211	Not Used
112	RLY 4 N.O.	212	Not Used
113	RLY 3 Com.	213	VA(+) Main
114	RLY 3 N.O.	214	VB(+) Main
115	Trip 2 Com.	215	VC(+) Main
116	Trip 2 N.O.	216	Vx1 Aux
117	Trip 1 Com.	217	Vx2 Aux
118	Trip 1 N.O.	218	Vg Main

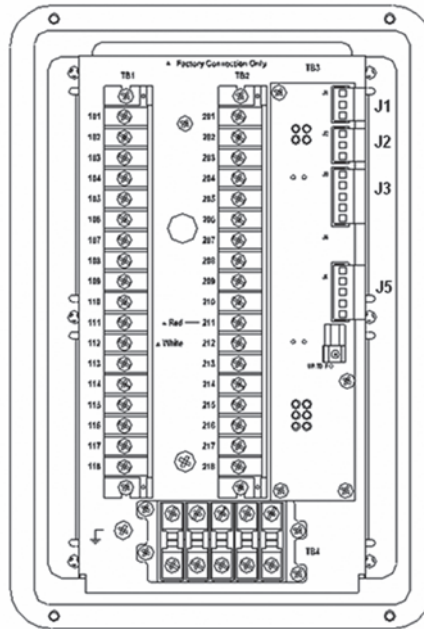

TB3	
J1-1	PowerNet
J1-2	PowerNet
J1-3	PowerNet Shield
J3-1	Zone Out
J3-2	Zone Com.
J3-3	Zone Shield
J3-4	Zone In
J3-5	Zone Com.
J4-1	
J4-2	
J4-3	
J5-1	RS485 (+) ①
J5-2	RS485 (-) ①
J5-3	RS485 Com. ①
J5-4	RS485 Shield ①

A1	B1	C1	X1	N.C.
A2	B2	C2	X2	N.C.

FP-6000 Front View and Drawout Case Side View

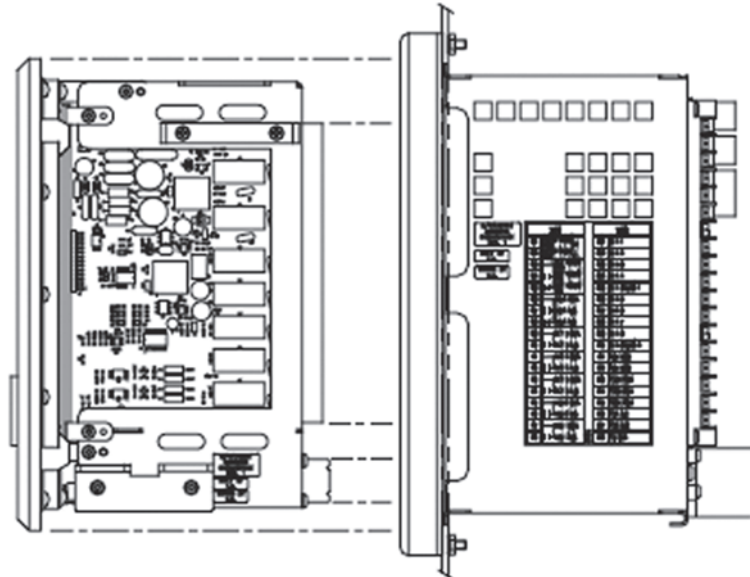
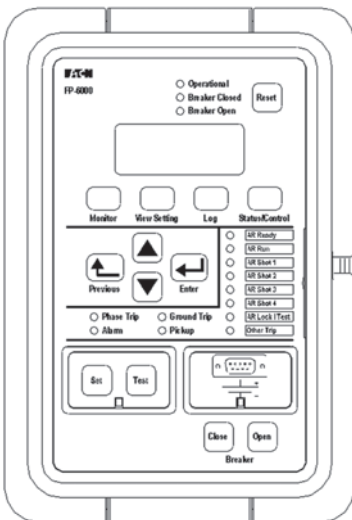

Note

① Available with Modbus-RTU communications.

FP-6000 Typical Connection Drawing Using Wye PTs

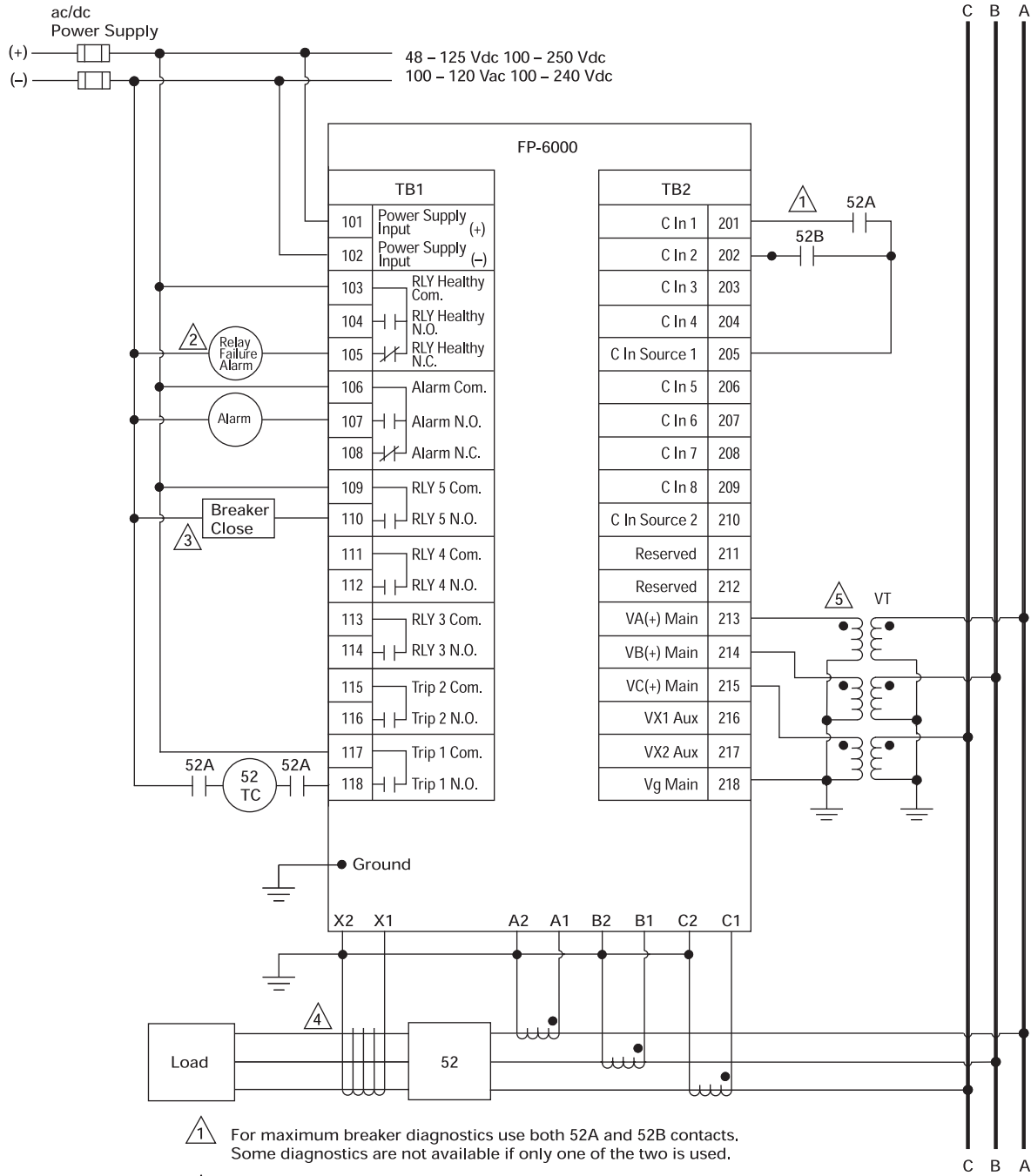

Dimensions

Approximate Dimensions in Inches (mm)

FP-6000 Feeder Protection Relay

Height	Width	Depth	Shipping Weight Lbs (kg)
In Front of Panel			
11.34 (288.0)	7.72 (196.1)	0.80 (20.3)	12.5 (5.7)
Behind Panel			
6.70 (170.2)	5.30 (134.6)	6.90 (175.3)	12.5 (5.7)

Feeder Protection FP-5000



Contents

Description	Page
Product Selection Guide	V3-T9-158
FP-6000 Feeder Protection	V3-T9-162
FP-5000 Feeder Protection	
Features, Benefits and Functions	V3-T9-173
Standards and Certifications	V3-T9-175
Catalog Number Selection	V3-T9-175
Technical Data and Specifications	V3-T9-176
Dimensions	V3-T9-179
FP-4000 Feeder Protection	V3-T9-180
MP-3000 Motor Protection	V3-T9-188
MP-4000 Motor Protection	V3-T9-198
MD-3000 Motor/Generator Differential Relay	V3-T9-204
Digitrip 3000	V3-T9-207
VR-300 Multifunctional Voltage Relay	V3-T9-217
DP-300 Current Differential Protection Relay	V3-T9-221
EDR-3000 Feeder Protection	V3-T9-226
ETR-4000 Transformer Protection Relay	V3-T9-237
Ground Fault Relay	V3-T9-250
Universal RTD Module	V3-T9-254
IQ 125 Volt DC Power Supply	V3-T9-258

FP-5000 Feeder Protection

Product Description

- Microprocessor-based protection with monitoring and control for medium voltage main and feeder applications
- Current, voltage, frequency and power protection for electric power distribution systems
- Complete metering of voltage, currents, power, energy, minimum/maximum and demand functions
- Programmable logic control functions for main-tie-main transfer schemes
- Trip logs, event logs and waveform capture for better fault analysis and system restoration
- Data Logger to provide energy usage profiles for better planning, utilization and energy usage
- Compact, drawout case design
- Meets ANSI, CE and CSA standards
- Multiple settings groups
- ANSI, IEC and thermal protection curves for greater flexibility

Application Description

Eaton's FP-5000 Feeder Protection relay provides complete three-phase and ground overcurrent and voltage protection plus metering in a single, compact drawout case. It may be used as primary protection on feeders, mains and tie circuit breaker applications, and as backup protection for transformers, high voltage lines and differential protection. The relay is most commonly used on medium voltage switchgear applications.

The FP-5000 takes full advantage of its microprocessor technology providing the user new freedoms and a wealth of data-gathering features. The relay performs self-checking of all major hardware and firmware protection elements to ensure their operation in the event of a system or component electrical failure or fault. Protection functions are well suited for main and distribution feeder circuit applications. Programmable logic control functions make

the FP-5000 relay ideally suited for main-tie-main and main 1/main 2 transfer schemes.

The Zone Interlocking feature can be utilized for bus protection instead of an expensive and complicated bus differential (87B) scheme. The FP-5000 works directly with Eaton's Digitrip 3000 and Digitrip MV relays. New breaker failure logic provides faster remote backup clearing times for stuck breaker operation.

The multiple settings groups can be utilized for arc flash mitigation when an alternative setting group, set to have instantaneous elements only is activated using a selector switch and the programmable I/O in the FP-5000.

The FP-5000 provides trip and close circuit monitoring and alarming features. It continually monitors the complete trip and close circuits for continuity and readiness to trip. Open and close pushbuttons are

conveniently located on the front of the relay for local breaker operation.

Loss-of-vacuum monitoring is activated when the breaker is open. Residual current is monitored and alarmed if detected.

When an electrical fault or disturbance occurs, the FP-5000 begins to store the following in non-volatile memory:

- Voltage and current sampled data
- Calculated values
- Status of internal protection functions, logic, contact inputs and outputs

Retrieval and viewing of the data is easy, aiding in the quick analysis and restoration of your electric power system.

Features, Benefits and Functions

When the FP-5000 isn't responding to disturbances in the power system, it's providing valuable metering information at the relay and remotely. It provides energy usage and demand reading, and can alarm when usage reaches a set value. Power factor measurements can be used for cap bank switching to control kVAR demand. Onboard data trending can provide load profiles for up to 40 days.

The protection functions are listed below and shown on **Page V3-T9-177**.

- Complete protection, metering and control in a single compact case to reduce panel space, wiring and costs
 - Flexible current, voltage and frequency protection and programmability to cover a broad range of applications while simplifying relay ordering and reducing inventory
 - Integral test function reduces maintenance time and expense
 - Relay self-diagnostics and reporting improves uptime and troubleshooting
 - Breaker trip circuit monitoring improves the reliability of the breaker operation
 - Programmable logic control features that can replace and eliminate external auxiliary relays, timers and wiring
 - Zone-selective interlocking improves coordination and tripping times and saves money compared to a traditional bus differential scheme
 - Trip and event recording in non-volatile memory provides detailed information for analysis and system restoration
 - 256 cycles of waveform capture aids in post fault analysis
 - Front RS-232 port and PowerPort software provides local computer access and a user-friendly, Windows®-based interface for relay settings, and configuration and data retrieval
 - Drawout case design for quick and easy relay removal and replacement
 - Breaker open/close control from relay faceplate or remotely via communications
 - Remote communications to Eaton's PowerNet monitoring system or PC
 - Free PowerPort utility software for local PC interface to the FP-5000 for relay settings, monitoring and control
- Phase Overcurrent (Forward, Reverse or Both)**
- Two-stage instantaneous with timers (50P-1 and 50P-2)
 - Two inverse time overcurrent (51P-1 and 51P-2)
 - Directional control
 - 10 standard curves
 - Instantaneous or time delay reset
 - Voltage restrained time overcurrent (51VR)
 - Two independent ground directional overcurrent elements, one measured (IX) and one calculated (IR)
 - Two-Stage instantaneous with timers (50X-1 and 50X-2) (50R-1 and 50R-2)
 - Inverse time overcurrent (51X and 51R)
 - Ground directional polarizing (67N) $-3_{V_{0r}}, I_{pol}$, negative sequence
 - 10 standard curves
 - Instantaneous or time delay reset
 - Voltage restrained time overcurrent (51VR)
 - Breaker failure (50BF)
 - Phase unbalance negative sequence overcurrent (46-1, 46-2)
 - Phase voltage unbalance and sequence protection (47-1, 47-2)
 - Main three-phase under/overvoltage (27M-1, 27M-2, 59M-1, 59M-2)
 - Auxiliary single-phase under/over-voltage (27A-1, 27A-2, 59A-1, 59A-2)
 - Under/over frequency (81U-1, 81U-2, 81O-1, 81O-2)
 - Reverse/forward power (32-1, 32-2)
 - Sync check (25)
 - Power factor (55)
 - Zone interlocking for bus protection (87B). The FP-5000 feeder relay includes a zone selective interlocking feature that can be used with other Eaton devices like the Digitrip 3000 overcurrent relay

The FP-5000 provides the following metering functions:

- Amperes (rms, phasor and sequence)
- Amperes demand and peak demand
- Volts (rms, phasor and sequence)
- VA and VA demand
- Watts and kW demand and peak demand
- Forward/reverse/net kWh
- VARs and kVAR demand and peak demand
- Lead/lag/net kVARh
- Power factor
- Frequency
- Voltage and current
- %THD and magnitude THD
- Minimum/maximum recording with date/time stamp
- Trending (load profile over time)

The FP-5000 provides the following monitoring and data recording functions that enhance the security of the protection system and provides useful information for scheduling maintenance:

- Trip circuit monitoring
- Close circuit monitoring
- Loss-of-vacuum monitoring
- Breaker wear (accumulated interrupted current)

- Waveform capture (256 cycles total, up to 16 events)
- Fault data logs (up to 16 events)
- Sequence of events report (up to 100 events)
- Clock

The FP-5000 provides standard control functions plus user-configurable custom control capabilities. This logic can be used for applications such as main-tie-main transfer schemes.

- Remote open/close
- Programmable I/O
- Programmable logic gates and timers
- Multiple setting groups (up to four)
- Bus transfer logic
- Cold load pickup
- Loss of potential (PT blown fuses)

The FP-5000 supports the following communication options:

- Local HMI
- Password protected
- Addressable
- Local communication port
- Remote communication port:
 - FSK
 - RS-232
 - RS-485
- Protocols:
 - INCOM
 - Modbus
- Configuration software

Communication Software

Eaton provides two types of communication software. The first is PowerPort. It runs on a PC or laptop for easy access to a single relay to change set points or configuration and to view metered values and stored data. PowerPort is free and can be downloaded from www.eaton.com; search for 'PowerPort,' then click the download search result.

The second package is PowerNet. PowerNet is a power management software package that is designed for continuous, remote monitoring of many devices. It provides all the functionality of PowerPort plus additional functions such as billing, trending and graphics. Contact your local Eaton representative for more information on PowerNet software.

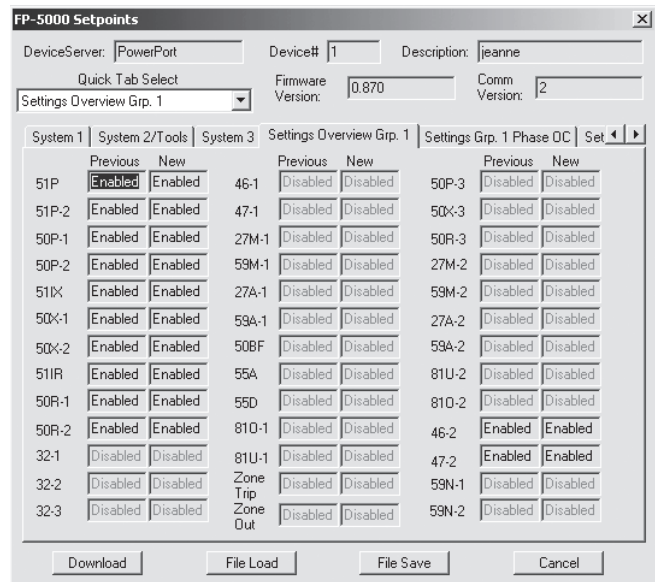

PowerPort and PowerNet Protection Overview Screen

Standards and Certifications

Compliance

- UL Recognized, File # E154862
- UL 1053 (1994) recognized
- ANSI C37.90 (1989)
- EN 55011 (1991)
- EN 61000-6-2 (1999)

Emission Tests

- EN 55011 (1991)—Group 1 Class A (CISPR-11, Class A)
- FCC 47 CFR Chapter 1—Part 15 Subpart b Class A

Immunity Tests

- ANSI C37.90.1 (1989)—Surge Withstand Capability
- ANSI C37.90.2 (1995)—EMI Immunity to 35V/m
- EN 61000-4-2 (1995)—ESD Rating of 8 kV
- EN 61000-4-3 (1997)—Radiated EM Field at 10V/m
- EN 61000-4-4 (1995)—Fast Transient Burst at 2 kV
- EN 61000-4-5 (1995)—Surge Immunity Test

- EN 61000-4-6 (1996)—Conducted RF at 10V/m
- EN 61000-4-11 (1994)—Voltage Dips and Variations
- EN 61000-4-8—Power Frequency Magnetic Field Immunity



Catalog Number Selection

FP-5000 Feeder Protection

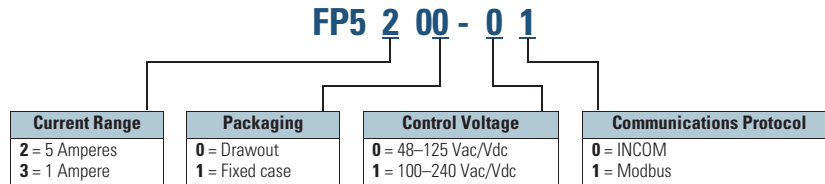

Technical Data and Specifications**Control Power**

- Control voltage:
 - 48–125 Vac/Vdc
 - 100–240 Vac/Vdc
- Operating voltage:
 - 55–264 Vac
 - 38–300 Vdc
- Interruption ride-through time: 20 cycle interruption of nominal ac supply
- Power consumption: 20 VA maximum

Current Inputs

- Nominal (I_n): 1A or 5A
- CT rating:
 - 2 x I_n continuous
 - 80 x I_n for 1 second
- CT burdens:
 - < 0.25 VA at 5A (nominal)
 - < 0.05 VA at 1A (nominal)

Voltage Transformer Inputs

- Nominal: 120 Vac
- Operating range: 69–150 Vac
- Burden:
 - <0.015 at 120 Vac
 - 1 megaohm

Metering Accuracy

- Phase current:
 - $\pm 0.5\%$ or $\pm 0.025A$ from 0.02–20 per unit fully offset current waveform
- Ground current:
 - $\pm 0.5\%$ of full scale (I_n) from 0.02–2.0 per unit fully offset current waveform
- Phase voltage: $\pm 0.5\%$ or $\pm 0.2V$ from 0–160 Vac
- Frequency measurement accuracy: ± 0.02 Hz
- Phase angle: $\pm 1^\circ C$
- Power metering accuracy: $\pm 1.5\%$
- Metering accuracy temperature range: 32°F to 122°F (0°C to 50°C)
- Temperature range: $\pm 5\%$ for operation below 32°F (0°C) and above 122°F (50°C)
- Relay outputs:
 - 2 Form C, NO and NC
 - 5 Form A, NO only

- Input signal frequency necessary for accurate operation:
 - 60 Hz nominal, 57–63 Hz ($\pm 5\%$)
 - 50 Hz nominal, 47–53 Hz ($\pm 5\%$)
- Clock accuracy:
 - Free running ± 1 minute/month at 25°C
 - Clock automatically updated by PowerNet host when present

Protective Functions**Phase and Ground Overcurrent Protection**

- Inverse characteristics: Mod, Very, Extremely, IECA, IECB, IECC, It, I²t, I⁴t, Flat
- TOC (51) pickup range: 0.1–4.0 per unit in 0.01 steps
- Time multipliers: 0.05–10.0 in 0.01 steps
- IOC (50) pickup range: 0.1–20.0 per unit in 0.01 steps
- Pickup accuracy: $\pm 1\%$ (at 0.1–2 per unit)
- Time delay: 0–9999 cycles in 1 cycle steps
- Time accuracy: $\pm 3\%$ or ± 30 ms
- Directional (67, 67N, 67G): forward, reverse or both

Voltage Unbalance (47)

- Threshold (minimum voltage) 1–100 volts in 1 volt steps
- % V₂/V₁: 4–40% in 1% steps
- Time delay: 0–9999 cycles in 1 cycle steps

Current Unbalance

- Threshold (minimum current) 0.1–20.0 per unit in 0.01 steps
- % I₂/I₁: 4–40% in 1% steps
- Time delay: 0–9999 cycles in 1 cycle steps

Under/Overvoltage Protection

- Pickup range: 10–150 volts in 1 volt steps
- Time delay: 0–9999 cycles in 1 cycle steps

Under/Over Frequency Protection

- Pickup range: 45–65 Hz in 0.01 Hz steps
- Time delay: 0–9999 cycles in 1 cycle steps

Breaker Failure Protection

- Pickup range: 0.1–5.0 per unit in 0.01 steps
- Time delay: 0–9999 cycles in 1 cycle steps

Power Protection (32)

- Forward/reverse: over/under
- Pickup accuracy: $\pm 1.0\%$
- Trip time accuracy: 0 to 12 cycles or 0.1%, whichever is greater

Sync Check (25)

- Phase angle: 1 to 60°C
- Slip frequency: 0.1 to 2 Hz
- Voltage differential: 1 to 100 volts
- Breaker close time: 0 to 9999 cycles

Power Factor

- Trigger/reset threshold: 0.5 lag to 0.5 lead in 0.01 steps
- Time delay: 0–1000 seconds in 1 second steps

Discrete Inputs

- Number of contact inputs: 8
- Rating: 48 Vdc wetting voltage provided with internal ground only

Output Contacts

- Number of output contacts: Five Form A and two Form C

Rating of Output Contacts

- Momentary:
 - Make 30A AC/DC for 0.25 seconds
 - Break 0.25A at 250 Vdc (resistive)
 - Break 5A at 120/240 Vac
- Continuous:
 - 5A at 120/240 Vac
 - 5A at 30 Vdc

Logic and Control Functions

- Six programmable logic gates for AND, OR, NAND, NOR operation
- Two latching (flip/flop) gates
- Six timer gates provide on/off delays

INCOM Communications

- Baud rate: 9600 fixed
- Maximum distance: 10,000 feet (3,048m)
- Protocol: INCOM

RS-485 Communications, Rear Panel

- Baud rate: 19.2K, 9.6K
- Protocol: Modbus RTU

RS-232 Communications, Front Panel

- Baud rate: 38.4K, 19.2K, 9.6K
- Connector standard 9-pin subminiature, three-wire
- Protocol: INCOM

Environmental Ratings

- Operating temperature: –0°F to +140°F (–40°C to +60°C) Product tested to +185°F (+85°C)
- Storage temperature: –40°F to +185°F (–40°C to +85°C)
- Humidity: 5–95% relative humidity (noncondensing)
- Altitude: 0–6350 feet (0–1935m) above Mean Sea Level

Wiring Diagrams

FP-5000 One-Line Drawing

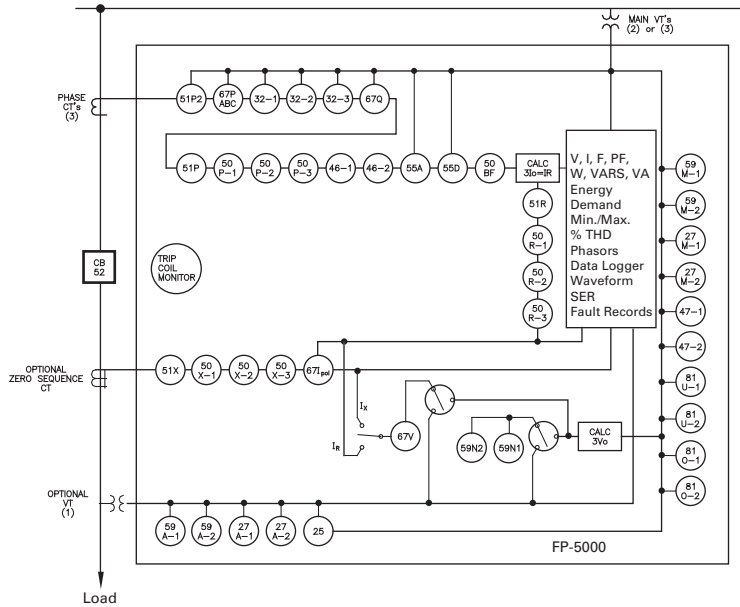

FP-5000 Rear View and Terminal Designations

TB1		TB2	
101	Power Supply Input (+)	201	C In 1
102	Power Supply Input (-)	202	C In 2
103	RLY Healthy Com.	203	C In 3
104	RLY Healthy N.O.	204	C In 4
105	RLY Healthy N.C.	205	C In Source 1
106	Alarm Com.	206	C In 5
107	Alarm N.O.	207	C In 6
108	Alarm N.C.	208	C In 7
109	RLY 5 Com.	209	C In 8
110	RLY 5 N.O.	210	C In Source 2
111	RLY 4 Com.	211	Not Used
112	RLY 4 N.O.	212	Not Used
113	RLY 3 Com.	213	VA(+) Main
114	RLY 3 N.O.	214	VB(+) Main
115	Trip 2 Com.	215	VC(+) Main
116	Trip 2 N.O.	216	Vx1 Aux
117	Trip 1 Com.	217	Vx2 Aux
118	Trip 1 N.O.	218	Vg Main

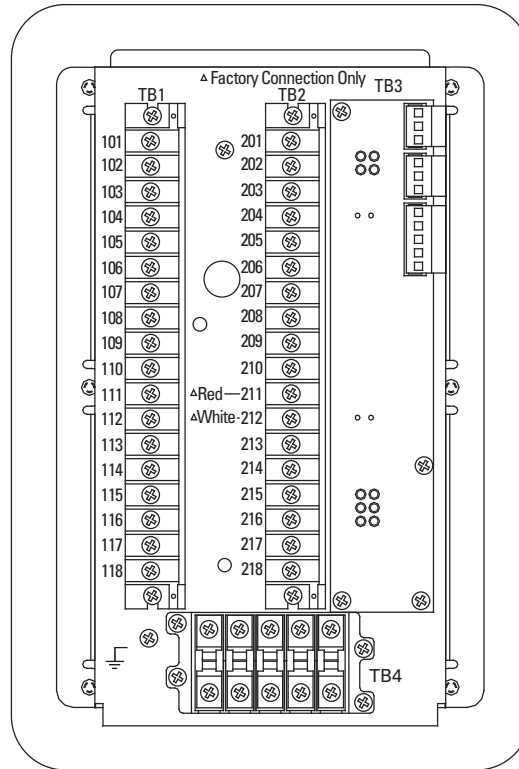

TB3	
J1-1	PowerNet
J1-2	PowerNet
J1-3	PowerNet Shield
J2-1	Accessory Bus
J2-2	Accessory Bus
J2-3	Accessory Bus Shield
J3-1	Zone Out
J3-2	Zone Com.
J3-3	Zone Shield
J3-4	Zone In
J3-5	Zone Com.
J4-1	
J4-2	
J4-3	
J5-1	RS485(+)
J5-2	RS485(-)
J5-3	RS485com
J5-4	RS485shield

A1	B1	C1	X1	N.C. 1
A2	B2	C2	X2	N.C. 2

FP-5000 Typical Connection Drawing Using Wye PTs

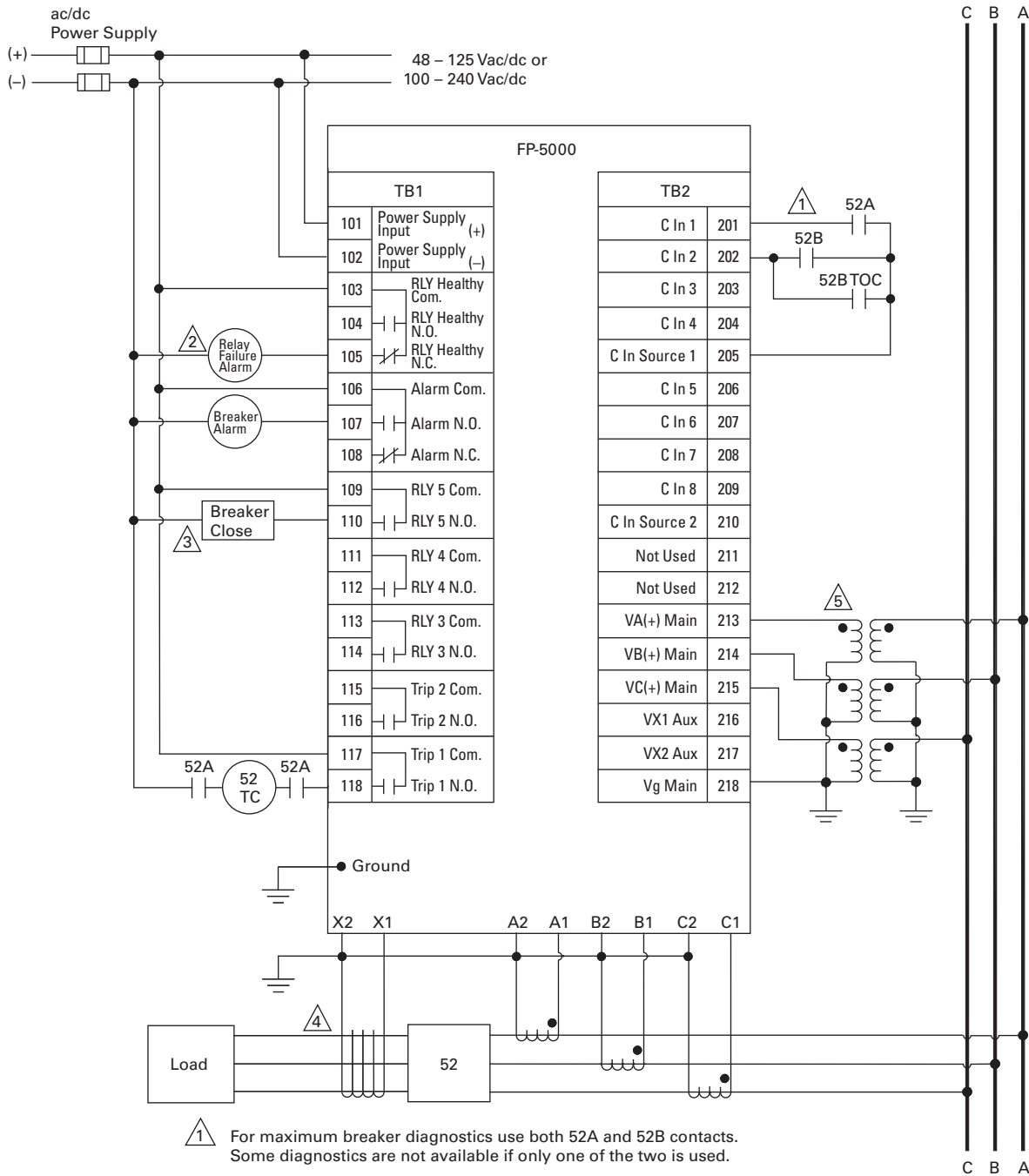

- 1 For maximum breaker diagnostics use both 52A and 52B contacts. Some diagnostics are not available if only one of the two is used.
- 2 A relay failure alarm should provide immediate attention as circuit is no longer protected. Relay failure output is normally energized.
- 3 FP-5000 can initiate a breaker close via the front panel interface and/or remote activation through communication or discrete input.
- 4 Residual connection may be used in place of zero sequence CT.
- 5 Delta or open delta PT connection may be used in place of wye-ground connection.

FP-5000 Front View and Drawout Case Side View

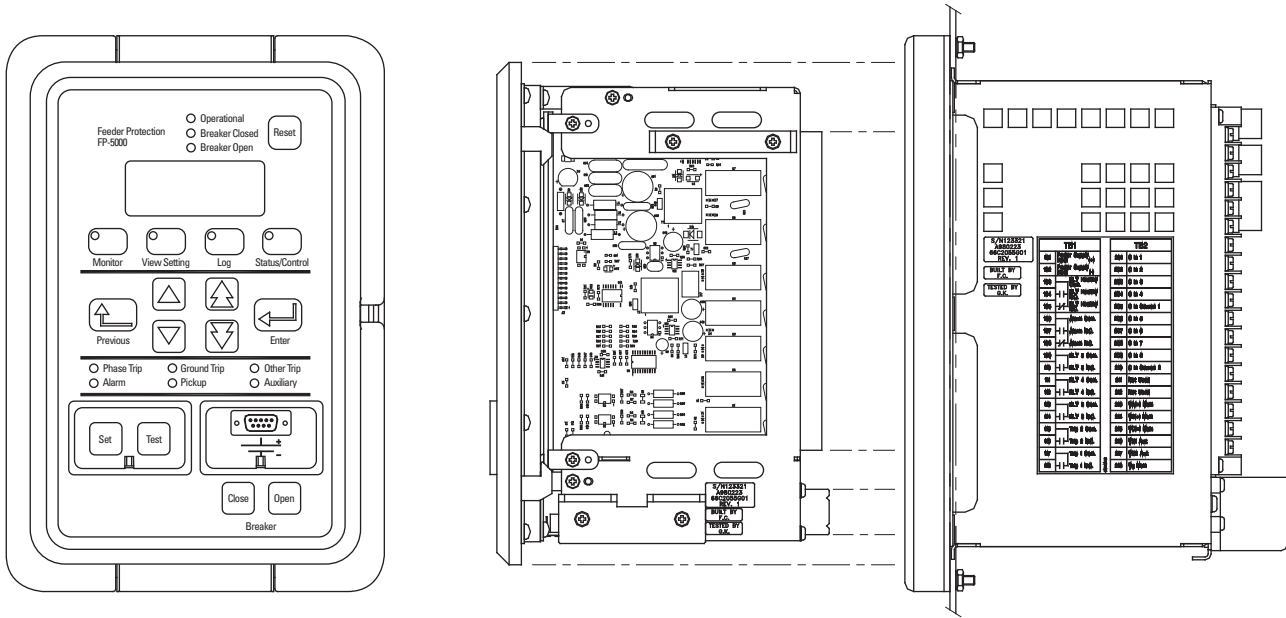

Dimensions

Approximate Dimensions in Inches (mm)

FP-5000 Feeder Protection Relay

Height	Width	Depth	Shipping Weight Lbs (kg)
In Front of Panel			
11.34 (288.0)	7.72 (196.1)	0.80 (20.3)	12.5 (5.7)
Behind Panel			
6.70 (170.2)	5.30 (134.6)	6.90 (175.3)	12.5 (5.7)

Feeder Protection FP-4000



Contents

<i>Description</i>	<i>Page</i>
Product Selection Guide	V3-T9-158
FP-6000 Feeder Protection	V3-T9-162
FP-5000 Feeder Protection	V3-T9-172
FP-4000 Feeder Protection	
Features, Benefits and Functions	V3-T9-181
Standards and Certifications	V3-T9-183
Catalog Number Selection	V3-T9-183
Technical Data and Specifications	V3-T9-184
Dimensions	V3-T9-187
MP-3000 Motor Protection	V3-T9-188
MP-4000 Motor Protection	V3-T9-198
MD-3000 Motor/Generator Differential Relay	V3-T9-204
Digitrip 3000	V3-T9-207
VR-300 Multifunctional Voltage Relay	V3-T9-217
DP-300 Current Differential Protection Relay	V3-T9-221
EDR-3000 Feeder Protection	V3-T9-226
ETR-4000 Transformer Protection Relay	V3-T9-237
Ground Fault Relay	V3-T9-250
Universal RTD Module	V3-T9-254
IQ 125 Volt DC Power Supply	V3-T9-258

FP-4000 Feeder Protection

Product Description

- Microprocessor-based protection with monitoring and control for medium voltage main and feeder applications
- Current, voltage, frequency and power protection for electric power distribution systems
- Complete metering of voltage, currents, power, energy, minimum/maximum and demand functions
- Programmable logic control functions for main-tie-main transfer schemes
- Trip logs, event logs and waveform capture for better fault analysis and system restoration
- Data logger to provide energy usage profiles for better planning, utilization and energy usage
- Compact, drawout case design
- Meets ANSI, CE and CSA standards
- Multiple settings groups
- ANSI, IEC and thermal protection curves for greater flexibility

Application Description

Eaton's FP-4000 Feeder Protection relay provides complete three-phase and ground overcurrent and voltage protection plus metering in a single, compact drawout case. It may be used as primary protection on feeders, mains and tie circuit breaker applications, and as backup protection for transformers, high voltage lines and differential protection. The relay is most commonly used on medium voltage switchgear applications.

The FP-4000 takes full advantage of its microprocessor technology providing the user new freedoms and a wealth of at-a-gathering features. The relay performs self-checking of all major hardware and firmware protection elements to ensure their operation in the event of a system or component electrical failure or fault. Protection functions are well suited for main and distribution feeder circuit applications. Programmable logic control functions make the FP-4000 relay ideally suited for main-tie-main and main 1/main 2 transfer schemes.

The Zone-Interlocking feature can be utilized for bus protection instead of an expensive and complicated bus differential (87B) scheme. The FP-4000 works directly with Eaton's Digitrip 3000 and Digitrip MV relays. New breaker failure logic provides faster remote backup clearing times for stuck breaker operation.

The multiple settings groups can be utilized for arc flash mitigation when an alternative setting group, set to have instantaneous elements only is activated using a selector switch and the programmable I/O in the FP-4000.

The FP-4000 provides trip and close circuit monitoring and alarming features. It continually monitors the complete trip and close circuits for continuity and readiness to trip. Open and close pushbuttons are conveniently located on the front of the relay for local breaker operation.

Loss-of-vacuum monitoring is activated when the breaker is open. Residual current is monitored and alarmed if detected.

When an electrical fault or disturbance occurs, the FP-4000 begins to store the following in non-volatile memory:

- Voltage and current sampled data
- Calculated values
- Status of internal protection functions, logic, contact inputs and outputs

Retrieval and viewing of the data is easy, aiding in the quick analysis and restoration of your electric power system.

Features, Benefits and Functions

When the FP-4000 isn't responding to disturbances in the power system, it's providing valuable metering information at the relay and remotely. It provides energy usage and demand reading, and can alarm when usage reaches a set value. Power factor measurements can be used for cap bank switching to control kVAR demand. Onboard data trending can provide load profiles for up to 40 days.

- Complete protection, metering and control in a single compact case to reduce panel space, wiring and costs
- Flexible current, voltage and frequency protection and programmability to cover a broad range of applications while simplifying relay ordering and reducing inventory
- Integral test function reduces maintenance time and expense
- Relay self-diagnostics and reporting improves uptime and troubleshooting
- Breaker trip circuit monitoring improves the reliability of the breaker operation
- Programmable logic control features that can replace and eliminate external auxiliary relays, timers and wiring
- Zone selective interlocking improves coordination and tripping times and saves money compared to a traditional bus differential scheme
- Trip and event recording in non-volatile memory provides detailed information for analysis and system restoration
- 256 cycles of waveform capture aids in post fault analysis
- Front RS-232 port and PowerPort software provides local computer access and a user-friendly, Windows X-based interface for relay settings, and configuration and data retrieval
- Breaker open/close control from relay faceplate or remotely via communications
- Remote communications to Eaton PowerNet monitoring system or PC
- Free PowerPort utility software for local PC interface to the FP-4000 for relay settings, monitoring and control

The protection functions are listed below and shown on **Page V3-T9-185**.

Phase Overcurrent

- Two-stage instantaneous with timers (50P-1 and 50P-2)
- Inverse time overcurrent (51P-1)
- 10 standard curves
- Instantaneous or time delay reset
- Two independent directional overcurrent elements, one measured (IX) and one calculated (IR)
 - Two-stage instantaneous with timers (50X-1 and 50X-2) (50R-1 and 50R-2)
 - Inverse time overcurrent (51X and 51R)
 - 10 standard curves
 - Instantaneous or time delay reset
- Breaker failure (50BF)
- Phase unbalance negative sequence overcurrent (46-1, 46-2)
- Phase voltage unbalance and sequence protection (47-1, 47-2)
- Main three-phase under/overvoltage (27M-1, 27M-2, 59M-1, 59M-2)

- Auxiliary single-phase under/overvoltage (27A-1, 27A-2, 59A-1, 59A-2)
- Under/overfrequency (81U-1, 81U-2, 81O-1, 81O-2)
- Power factor (55)
- Zone interlocking for bus protection (87B). The FP-4000 feeder relay includes a zone selective interlocking feature that can be used with other Eaton devices like the Digitrip 3000 overcurrent relay

The FP-4000 provides the following metering functions:

- Amperes (rms, phasor and sequence)
- Amperes demand and peak demand
- Volts (rms, phasor and sequence)
- VA and VA demand
- Watts and kW demand and peak demand
- Forward/reverse/net kWh
- VARs and kVAR demand and peak demand
- Lead/lag/net kVARh
- Power factor
- Frequency
- Voltage and current
- %THD and magnitude THD
- Minimum/maximum recording with date/time stamp
- Trending (load profile over time)

The FP-4000 provides the following monitoring and data recording functions that enhance the security of the protection system and provides useful information for scheduling maintenance:

- Trip circuit monitoring
- Close circuit monitoring
- Loss-of-vacuum monitoring
- Breaker wear (accumulated interrupted current)

- Waveform capture (256 cycles total, up to 16 events)
- Fault data logs (up to 16 events)
- Sequence of events report (up to 100 events)
- Clock

The FP-4000 provides standard control functions plus user-configurable custom control capabilities. This logic can be used for applications such as main-tie-main transfer schemes.

- Remote open/close
- Programmable I/O
- Programmable logic gates and timers
- Multiple setting groups (up to four)
- Bus transfer logic

The FP-4000 supports the following communication options:

- Local HMI
- Password protected
- Addressable
- Local communication port
- Remote communication port:
 - FSK
 - RS-232
 - RS-485
- Protocols:
 - INCOM
 - Modbus
- Configuration software

Communication Software

Eaton provides two types of communication software. The first is PowerPort. It runs on a PC or laptop for easy access to a single relay to change set points or configuration and to view metered values and stored data. PowerPort is free and can be downloaded from www.eaton.com; search for 'PowerPort,' then click the download search result.

The second package is PowerNet. PowerNet is a power management software package that is designed for continuous, remote monitoring of many devices. It provides all the functionality of PowerPort plus additional functions such as billing, trending and graphics. Contact your local Eaton representative for more information on PowerNet software.

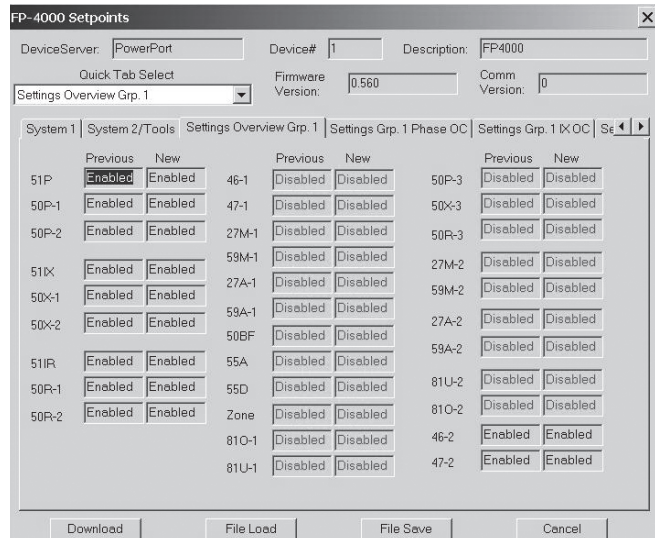

PowerPort and PowerNet Protection Overview Screen

Standards and Certifications

Compliance

- UL Recognized, File # E154862
- UL 1053 (1994) recognized
- ANSI C37.90 (1989)
- EN 55011 (1991)
- EN 61000-6-2 (1999)

Emission Tests

- EN 55011 (1991)—Group 1 Class A (CISPR-11, Class A)
- FCC 47 CFR Chapter 1—Part 15 Subpart b Class A

Immunity Tests

- ANSI C37.90.1 (1989)—Surge Withstand Capability
- ANSI C37.90.2 (1995)—EMI Immunity to 35V/m.
- EN 61000-4-2 (1995)—ESD Rating of 8 kV
- EN 61000-4-3 (1997)—Radiated EM Field at 10V/m
- EN 61000-4-4 (1995)—Fast Transient Burst at 2 kV
- EN 61000-4-5 (1995)—Surge Immunity Test
- EN 61000-4-6 (1996)—Conducted RF at 10V/m

- EN 61000-4-11 (1994)—Voltage Dips and Variations
- EN 61000-4-8—Power Frequency Magnetic Field Immunity



Catalog Number Selection

FP-4000 Feeder Protection

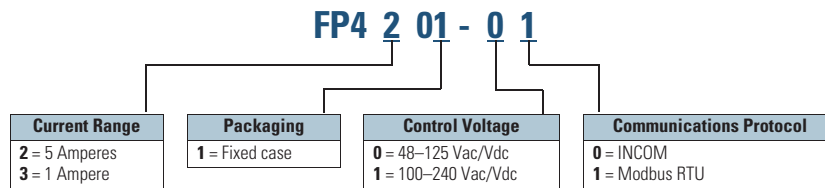

Technical Data and Specifications

Control Power

- Control voltage:
 - 48–125 Vac/dc
 - 100–240 Vac/dc
- Operating voltage:
 - 55–264 Vac
 - 38–300 Vdc
- Interruption ride-through time: 20 cycle interruption of nominal ac supply
- Power consumption: 20 VA maximum

Current Inputs

- Nominal (I_n): 1A or 5A
- CT rating:
 - $2 \times I_n$ continuous
 - $80 \times I_n$ for 1 second
- CT burdens:
 - < 0.25 VA at 5A (nominal)
 - < 0.05 VA at 1A (nominal)

Voltage Transformer Inputs

- Nominal: 120 Vac
- Operating range: 69–150 Vac
- Burden:
 - <0.015 at 120 Vac
 - 1 megaohm

Metering Accuracy

- Phase current:
 - $\pm 0.5\%$ or $\pm 0.025A$ from 0.02–20 per unit fully offset current waveform
- Ground current:
 - $\pm 0.5\%$ of full scale (I_n) from 0.02–2.0 per unit fully offset current waveform
- Phase voltage: $\pm 0.5\%$ or $\pm 0.2V$ from 0–160 Vac
- Frequency measurement accuracy: ± 0.02 Hz
- Phase angle: $\pm 1^\circ C$
- Power metering accuracy: $\pm 1.5\%$
- Metering accuracy temperature range: 32°F to 122°F (0°C to 50°C)
- Temperature range: $\pm 5\%$ for operation below 32°F (0°C) and above 122°F (50°C)
- Relay outputs:
 - 2 Form C, NO and NC
 - 5 Form A, NO Only

- Input signal frequency necessary for accurate operation:
 - 60 Hz nominal, 57–63 Hz ($\pm 5\%$)
 - 50 Hz nominal, 47–53 Hz ($\pm 5\%$)
- Clock accuracy:
 - Free running ± 1 minute/month at 77°F (25°C)
 - Clock automatically updated by PowerNet host when present

Protective Functions

Phase and Ground Overcurrent Protection

- Inverse characteristics: Mod, Very, Extremely, IECA, IECB, IECC, It, I²t, I⁴t, Flat
- TOC (51) pickup range: 0.1–4.0 per unit in 0.01 steps
- Time multipliers: 0.05–10.0 in 0.01 steps
- IOC (50) pickup range: 0.1–20.0 per unit in 0.01 steps
- Pickup accuracy: $\pm 1\%$ (at 0.1–2 per unit)
- Time delay: 0–9999 cycles in 1 cycle steps
- Time accuracy: $\pm 3\%$ or ± 30 ms

Voltage Unbalance (47)

- Threshold (minimum voltage) 1–100 volts in 1 volt steps
- % V_2/V_1 : 4–40% in 1% steps
- Time delay: 0–9999 cycles in 1 cycle steps

Current Unbalance

- Threshold (minimum current) 0.1–20.0 per unit in 0.01 steps
- % I_2/I_1 : 4–40% in 1% steps
- Time delay: 0–9999 cycles in 1 cycle steps

Under/Overvoltage Protection

- Pickup range: 10–150 volts in 1 volt steps
- Time delay: 0–9999 cycles in 1 cycle steps

Under/Overfrequency Protection

- Pickup range: 45–65 Hz in 0.01 Hz steps
- Time delay: 0–9999 cycles in 1 cycle steps

Breaker Failure Protection

- Pickup range: 0.1–5.0 per unit in 0.01 steps
- Time delay: 0–9999 cycles in 1 cycle steps

Power Factor

- Trigger/reset threshold: 0.5 lag to 0.5 lead in 0.01 steps
- Time delay: 0–1000 seconds in 1 second steps

Discrete Inputs

- Number of contact inputs: 8
- Rating: 48 Vdc wetting voltage provided with internal ground only

Output Contacts

- Number of output contacts: Five Form A and two Form C

Rating of Output Contacts

- Momentary:
 - Make 30A AC/DC for 0.25 seconds
 - Break 0.25A at 250 Vdc (resistive)
 - Break 5A at 120/240 Vac
- Continuous:
 - 5A at 120/240 Vac
 - 5A at 30 Vdc
 - Logic and Control Functions
- Six programmable logic gates for AND, OR, NAND, NOR operation
- Two latching (flip/flop) gates
- Six timer gates provide on/off delays

INCOM Communications

- Baud rate: 9600 fixed
- Maximum distance: 10,000 feet (3048 m)
- Protocol: INCOM

RS-485 Communications, Rear Panel:

- Baud rate: 19.2K, 9.6K
- Protocol: Modbus RTU

RS-232 Communications, Front Panel

- Baud rate: 38.4K, 19.2K, 9.6K
- Connector standard 9-pin subminiature, three-wire
- Protocol: INCOM

Environmental Ratings

- Operating temperature: –40°F to +140°F (–40°C to +60°C) Product tested to +185°F (+85°C)
- Storage temperature: –40°F to +185°F (–40°C to +85°C)
- Humidity: 5–95% relative humidity (noncondensing)
- Altitude: 0–6350 feet (0–1935m) above Mean Sea Level

Wiring Diagrams

FP-4000 One-Line Drawing

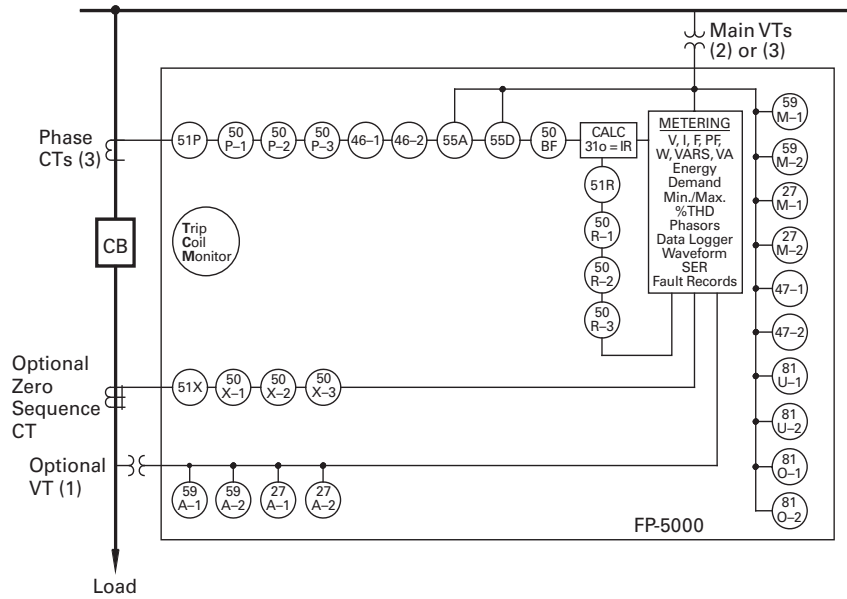

FP-4000 Rear View and Terminal Designations

TB1		TB2	
101	Power Supply Input (+)	201	C In 1
102	Power Supply Input (-)	202	C In 2
103	RLY Healthy Com.	203	C In 3
104	RLY Healthy N.O.	204	C In 4
105	RLY Healthy N.C.	205	C In Source 1
106	Alarm Com.	206	C In 5
107	Alarm N.O.	207	C In 6
108	Alarm N.C.	208	C In 7
109	RLY 5 Com.	209	C In 8
110	RLY 5 N.O.	210	C In Source 2
111	RLY 4 Com.	211	Not Used
112	RLY 4 N.O.	212	Not Used
113	RLY 3 Com.	213	VA(+) Main
114	RLY 3 N.O.	214	VB(+) Main
115	Trip 2 Com.	215	VC(+) Main
116	Trip 2 N.O.	216	Vx1 Aux
117	Trip 1 Com.	217	Vx2 Aux
118	Trip 1 N.O.	218	Vg Main

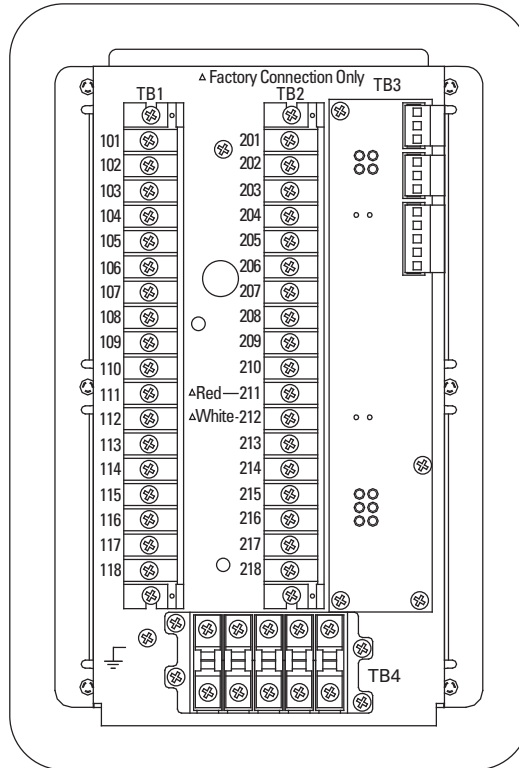

TB3	
J1-1	PowerNet
J1-2	PowerNet
J1-3	PowerNet Shield
J2-1	Accessory Bus
J2-2	Accessory Bus
J2-3	Accessory Bus Shield
J3-1	Zone Out
J3-2	Zone Com.
J3-3	Zone Shield
J3-4	Zone In
J3-5	Zone Com.
J4-1	
J4-2	
J4-3	
J5-1	RS485(+)
J5-2	RS485(-)
J5-3	RS485com
J5-4	RS485shield

A1	B1	C1	X1	N.C. 1
A2	B2	C2	X2	N.C. 2

FP-4000 Typical Connection Drawing Using Wye PTs

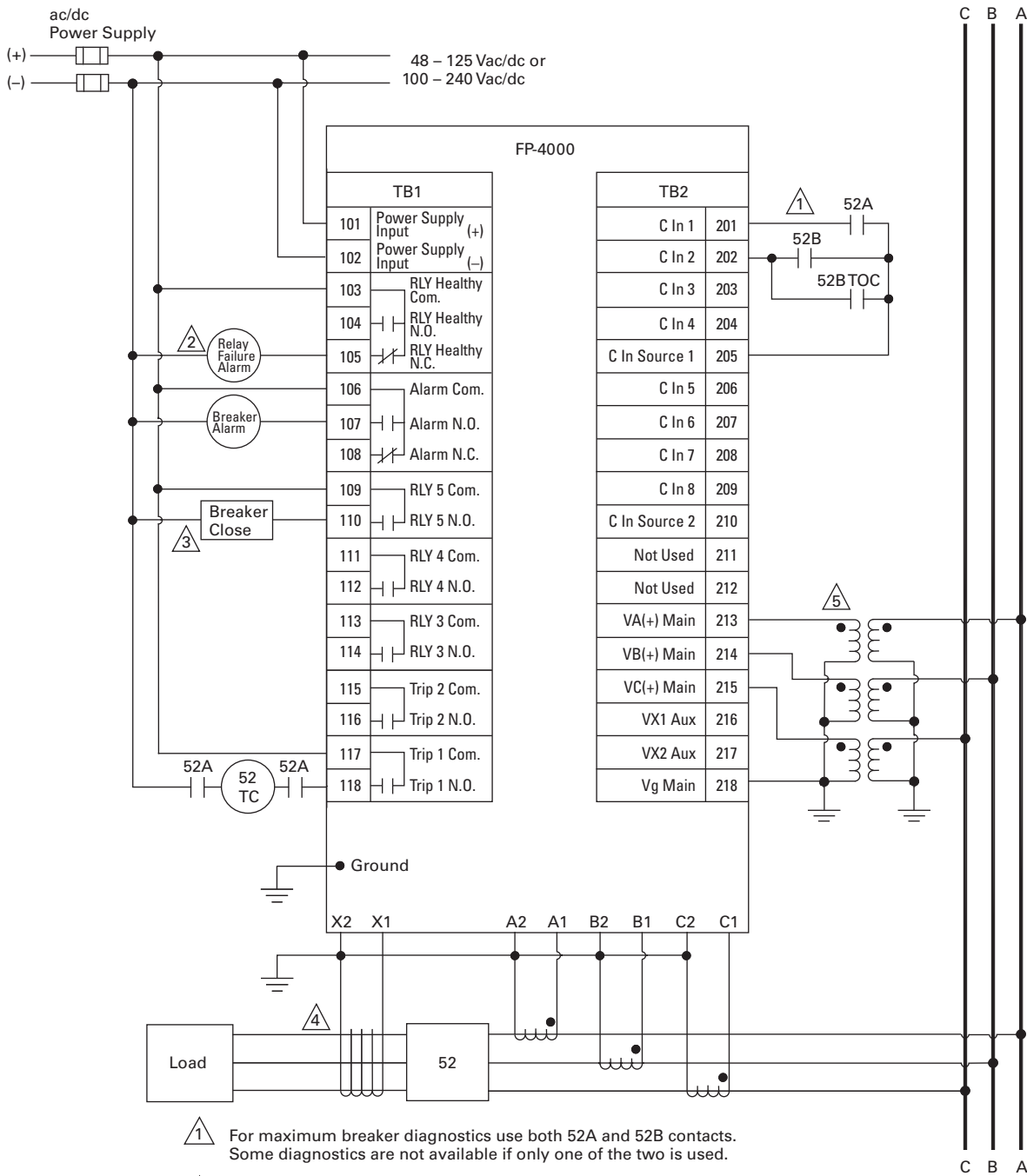

- 1 For maximum breaker diagnostics use both 52A and 52B contacts. Some diagnostics are not available if only one of the two is used.
- 2 A relay failure alarm should provide immediate attention as circuit is no longer protected. Relay failure output is normally energized.
- 3 FP-4000 can initiate a breaker close via the front panel interface and/or remote activation through communication or discrete input.
- 4 Residual connection may be used in place of zero sequence CT.
- 5 Delta or open delta PT connection may be used in place of wye-ground connection.

Dimensions

Approximate Dimensions in Inches (mm)

FP-4000 Feeder Protection Relay

Height	Width	Depth	Shipping Weight Lbs (kg)
In Front of Panel			
10.15 (257.9)	7.62 (193.5)	0.62 (15.7)	9.0 (4.1)
Behind Panel			
10.15 (257.9)	7.62 (193.5)	7.48 (190.0)	9.0 (4.1)

MP-3000



Contents

<i>Description</i>	<i>Page</i>
Product Selection Guide	V3-T9-158
FP-6000 Feeder Protection	V3-T9-162
FP-5000 Feeder Protection	V3-T9-172
FP-4000 Feeder Protection	V3-T9-180
MP-3000 Motor Protection	
Features, Benefits and Functions	V3-T9-189
Standards and Certifications	V3-T9-189
Product Selection	V3-T9-190
Options and Accessories	V3-T9-190
Technical Data and Specifications	V3-T9-191
Dimensions	V3-T9-195
MP-4000 Motor Protection	V3-T9-198
MD-3000 Motor/Generator Differential Relay	V3-T9-204
Digitrip 3000	V3-T9-207
VR-300 Multifunctional Voltage Relay	V3-T9-217
DP-300 Current Differential Protection Relay	V3-T9-221
EDR-3000 Feeder Protection	V3-T9-226
ETR-4000 Transformer Protection Relay	V3-T9-237
Ground Fault Relay	V3-T9-250
Universal RTD Module	V3-T9-254
IQ 125 Volt DC Power Supply	V3-T9-258

MP-3000 Motor Protection

Product Description

- Microprocessor-based, multi-function motor protection
- Current only device—no need to add PTs
- Intel-I-Trip™ overload protection based on motor data
- Event recording and operational logging
- Motor Start Profile™
- Optional Quick Release Drawout Case
- Used on AMPGARD® and medium voltage assemblies
- “Help” menu provides user operational assistance

Application Description

Eaton’s MP-3000 motor protection relay is a multifunctional microprocessor-based protective relay for the protection of three-phase AC motors. The MP-3000 motor relay may be applied to any size motor at any voltage level. It is most commonly used on large, medium voltage three-phase induction motors. It has also been widely used on important low voltage (480 volt) motor applications and synchronous motors.

The MP-3000 motor relay is a current only device that monitors three-phase and ground currents. It provides motor overload, stall, short circuit, phase unbalance, single phasing and ground fault motor protection.

It can also be used to provide protection for a load jam or loss of load condition. Please refer to **Page V3-T9-192**.

The MP-3000 motor relay provides start control logic to protect the motor against excessive starts or starting the motor before it has had sufficient time to cool down. The MP-3000 motor relay may be applied to either across the line starters or reduced voltage starters. On reduced voltage starters, the MP-3000 relay can control the switch from reduced voltage to full voltage based on time and/or motor transition. The MP-3000 can protect the starter against failure to transition to full voltage through contact feedback and an incomplete sequence function.

The MP-3000 motor relay is generally used on a motor starter or a breaker used for a motor load. The MP-3000 motor relay provides the intelligence to protect and control the motor against abnormal operating conditions. It monitors the currents from either a 5A or 1A secondary of a CT circuit. Ground current may be obtained from either a ground CT or from the residual connection of the phase CTs. It provides a Form C contact output for controlling the starter contacts or breaker operation.

Features, Benefits and Functions

- Complete motor protection and control in a single compact case reduces panel space requirements and wiring costs
- Microprocessor design with self diagnostics eliminates calibration and reduces installation, commissioning and maintenance
- Programmable stop 2–20% of PCT
- Intel-I-Trip overload protection develops customized curve from manufacturer's supplied motor data
- Intel-I-Trip overload protection provides adaptive trip characteristics based on motor temperature when motor RTDs are connected through an optional URTD module
- Meets UL 1053 ground fault protection standards that eliminates the need for a separate ground relay saving cost, space, wiring and time
- Voltage dip/loss ride through capability reduces unnecessary trips caused by poor power quality
- Motor currents, temperatures and conditions are monitored and displayed either locally or remotely
- Event log provides motor operating records for the most recent 20 Trip or Alarm events with date and time stamping. This information can improve troubleshooting and reduce downtime
- Log book records the most recent 100 events such as motor START/STOP and set point changes to provide a log of motor operation with date and time stamping
- RTD diagnostics reduces unnecessary tripping caused by faulty RTD, RTD wiring or communications
- Arm/Disarm feature improves security for critical motor applications
- Motor Start profile verifies protection and motor starting coordination. This feature can be used to develop protection settings on old motors where data is not available
- Optional communication module and Eaton's software simplifies setting, configuration, monitoring, commissioning and data retrieval either locally or remotely
- Optional Quick Release Drawout Case construction simplifies relay removal and replacement

The protection functions are listed below.

- I²t overload protection (49/51)
- Locked rotor (49S/51)
- Ultimate trip current (51)
- Negative sequence phase unbalance (46)
- Instantaneous overcurrent (50)
- Ground fault protection (50G)
- RTD trip and alarm with URTD module (49/38)
- Underload trip (37)
- Starts per time (66)
- Jam or stall (51R)
- Auto or manual reset (86)
- Fail-safe or non-fail-safe trip modes

The metering functions are:

- Motor currents:
 - Average current (I_{ave})
 - Individual phase and ground current in primary amperes
 - Percent of full load
 - Percent of phase unbalance
- RTD temperatures:
 - Individual winding
 - Motor bearing
 - Load
 - Auxiliary temperatures
- Motor conditions:
 - Percent of I²t thermal bucket
 - Time before start
 - Remaining starts allowed
 - Oldest start time

Standards and Certifications

The MP-3000 motor protection was designed to meet the industry standards for protective relays. It is recognized under UL 1053 Ground Fault Protection Standard.

- UL recognized (File No. E154862)
- UL 1053 recognized
- UL 508 recognized
- ANSI C37.90, C37.90.1
- cUL
- CSA



Product Selection

MP-3000

MP-3000



Description	Catalog Number
MP-3000 Drawout, 5A with RS-232	MP3011
MP-3000 Drawout, INCOM, 5A with RS-232	MP3012
MP-3000 Drawout, Modbus, 5A with RS-232	MP3013
MP-3000 Drawout, DeviceNet, 5A with RS-232	MP3014
MP-3000 Drawout, 1A with RS-232	MP3111
MP-3000 Drawout, INCOM, 1A with RS-232	MP3112
MP-3000 Drawout, Modbus, 1A with RS-232	MP3113
MP-3000 Drawout, DeviceNet, 1A with RS-232	MP3114
MP-3000 Fixed Case, 5A with RS-232	MP3010
MP-3000 Fixed Case, INCOM, 5A with RS-232	MP3010-INCOM
MP-3000 Fixed Case, Modbus, 5A with RS-232	MP3010MODBUS
MP-3000 Fixed Case, DeviceNet, 5A with RS-232	MP3010DEVICEN
MP-3000 Fixed Case, 1A with RS-232	MP3110
MP-3000 Fixed Case, INCOM, 1A with RS-232	MP3110-INCOM
MP-3000 Fixed Case, Modbus, 1A with RS-232	MP3110MODBUS
MP-3000 Fixed Case, DeviceNet, 1A with RS-232	MP3110DEVICEN
MP-3000 Fixed Case, INCOM, 5A with RS-232, URTD	MP3010VPI
MP-3000 Fixed Case, Modbus, 5A with RS-232, URTD	MP3010VPM
MP-3000 Fixed Case, DeviceNet, 5A with RS-232, URTD	MP3010VPD
MP-3000 Fixed Case, INCOM, 1A with RS-232, URTD	MP3110VPI
MP-3000 Fixed Case, Modbus, 1A with RS-232, URTD	MP3110VPM
MP-3000 Fixed Case, DeviceNet, 1A with RS-232, URTD	MP3110VPD

Options and Accessories

Additional Related Products by Eaton's Cutler-Hammer® Series

The MP-3000 is available in either a fixed mount or Quick Release Drawout Case. Both mountings use the same panel cutout. **Page V3-T9-195** shows cutout dimensions. **Page V3-T9-192** shows a typical fixed mount wiring diagram for a medium voltage motor starter application. **Page V3-T9-193** shows the fixed mount terminal designation. **Page V3-T9-195** shows the drawout case panel mounting, and shows the drawout case terminal designation.

The Universal RTD module (URTD) is required when the motor is equipped with RTDs that you wish to monitor and use for protection. The URTD can be mounted near the motor to reduce RTD wiring and costs. **Page V3-T9-194** shows MP-3000 and URTD inter-connection wiring. Please refer to the URTD information described elsewhere in this catalog.

The MP-3000 motor protection is designed to operate from 120 Vac or 240 Vac auxiliary control power. The MP-3000 motor relay can be used with DC control power with the addition of the IQDCPS. The IQDCPS is an inverter from DC to AC.

Technical Data and Specifications
Control Power

- Nominal rating:
 - 120 Vac or 240 Vac
 - +10%, -25%
- Operating range:
 - 120 Vac: 90 132 Vac
 - 240 Vac: 180 264 Vac
- Frequency: 50 or 60 Hz
- Power use:
 - 20 VA maximum
 - URTD: 6 VA maximum
 - IPONI: 1 VA maximum
- Ride-through time: 30 cycles from nominal Vac

Current Inputs

- Nominal (I_n): 1A or 5A
- CT rating:
 - 2 x I_n continuous
 - 50 x I_n for 1 second
- Burdens:
 - < 0.25 VA at 5A
 - < 0.05 VA at 1A

Metering Accuracy

- Phase current: $\pm 1\%$ of I_n (5–100%)
- Ground current: $\pm 1.5\%$ of I_n (0–55%)

Discrete Inputs

- Number of inputs: two programmable
- Ratings:
 - 1.2 VA at 120 Vac
 - Maximum off = 36 Vac
 - Minimum on = 86 Vac

Output Contacts

- Number of outputs: four Form C, programmable
- Momentary:
 - Make 30A AC/DC for 0.25 seconds
 - Break 0.25A at 250 Vdc (resistive)
 - Break 5A at 120 240 Vac
- Continuous:
 - 5A at 120/240 Vac
 - 5A at 30 Vdc

Analog Output

- Rating: ± 4 –20 mA programmable
- Maximum load: 1K ohm
- Accuracy: 1%

Motor Overload Protection (I^2t)

- Full load amperes: 10–3000A
- Locked rotor current: 300–1200% FLA
- Locked rotor time: 1–120 seconds
- Ultimate trip current: 85–150% FLA
- Phase CT ratio: 10–4000 (I_n)
- Ground CT ratio: 10–4000 (I_n)
- Timing accuracy: $\pm 2.5\%$ or ± 30 mS for $I > 1.1 \times U.T.C$

Trip Setting Range

- Ground fault (GF): Off, 2–55% CT ratio
- GF start time delay: 2–60 cycles
- GF run time delay: 0–60 cycles
- Timer accuracy: ± 20 mS
- Instantaneous O.C.: Off, 300–1600% FLA
- IOC start time delay: 2–60 cycles
- Timer accuracy: ± 20 mS
- JAM trip: Off, 100–1200% FLA
- Underload trip: Off, 1–90% FLA
- Phase unbalance trip: Off, 4–40% I_{neg}/I_{pos}
- Start delay timers:
 - 0–120 seconds (underload and phase unbalance)
 - 0–1200 seconds (jam)
- Run delay timers: 0–240 seconds
- Timer accuracy: $\pm 0.5\%$ +100 mS

Alarm Setting Range

- Ground fault: Off, 2–55% CT ratio
- Overload I^2t : Off, 60–99% I^2t
- JAM: Off, 100–1200% FLA
- Underload: Off, 1–90% FLA
- Phase unbalance: Off, 4–40% I_{neg}/I_{pos}
- Run delay timers: 0–240 seconds

Start Control Functions

- Starts per time: 1–10 starts
- Time for starts per time: Off, 1–240 minutes
- Time between starts: Off, 1–240 minutes
- Number of cold starts: 1–5 starts
- Motor transition current: 10–300% FLA
- Time for transition: 0–1200 seconds
- Inc. sequence timer: Off, 1–240 seconds
- Long acceleration timer: Off, 1–1200 seconds
- Anti-Backspin timer: Off, 1–3600 minutes

RTD Inputs (Requires URTD module)

- Sensor types:
 - 10 ohm copper
 - 100 ohm nickel
 - 120 ohm nickel
 - 100 ohm platinum

URTD Module Communications

- Interface:
 - Electrical (three-wire)
 - Fiber optic (preferred)
- Fiber optic cable: Type HBFR-ERS or EUS

Clock

- Accuracy: ± 1 minute/month at 77°F (25°C)

IPONI Communications

- Type: two-wire, FSK
- Baud rate: 1200 or 9600 baud
- Protocol: INCOM
- Functions:
 - Read/write set points
 - Read metered values
 - Read trip/alarms
 - Read events/history
 - View starting profile

MPONI Communications

- Type: 5-wire, 485
- Baud rate: 1200 or 9600 baud
- Protocol: Modbus RTU
- Functions:
 - Read/write set points
 - Read metered values
 - Read trip/alarms
 - Read events/history
 - View starting profile

DPONI Communications

- Type: J-wire
- Baud rate: 500k, 250k, 125k
- Protocol: DeviceNet
- Functions:
 - Read metered values
 - Read trip/alarms

Logging

- Log book: 100 events
- Log event: 20 trips and alarms
- Log start: last four starts
- Start profile: last four starts (communication only)
- History records: motor, trips, alarms and total records

Environmental Conditions

- Operating temperature: -4°F to 140°F (-20°C to +60°C)
- Storage temperature: -49°F to +185°F (-45°C to +85°C)
 - Humidity: 0–95% noncondensing

Wiring Diagrams

MP-3000 Motor Relay Protection Functions

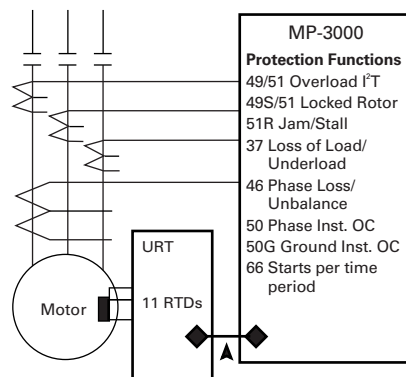

9

MP-3000 Fixed Mount Typical

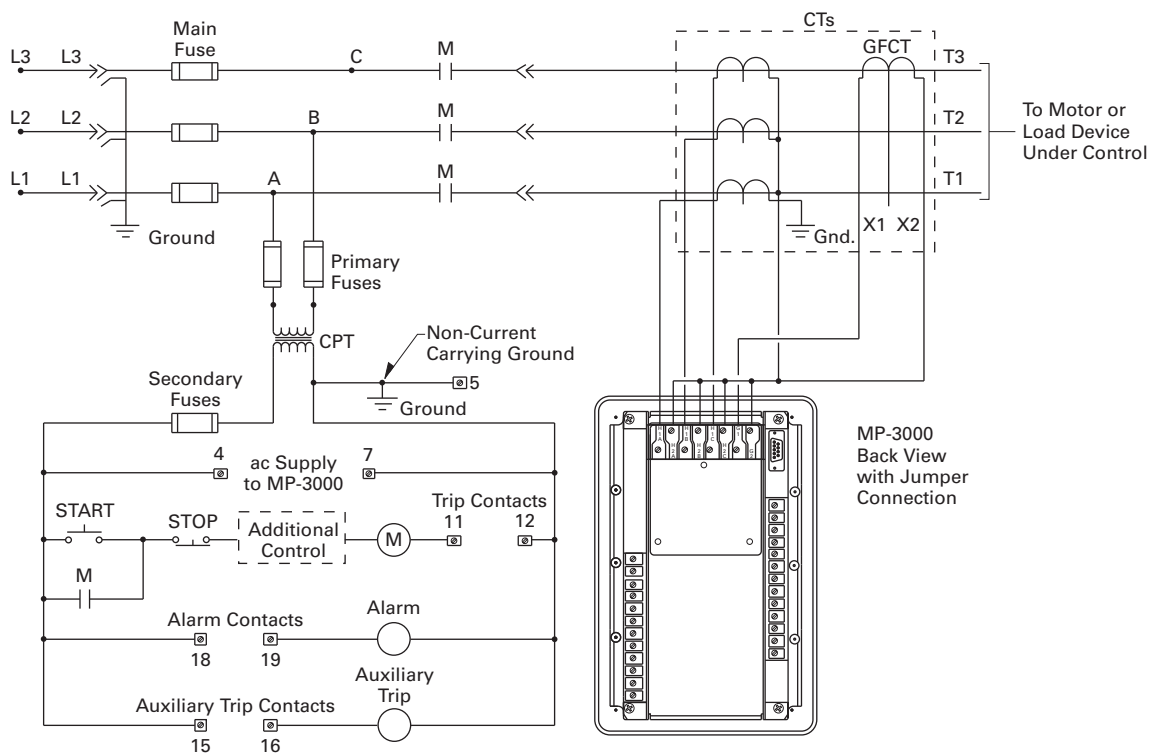

MP-3000 Terminal Identification

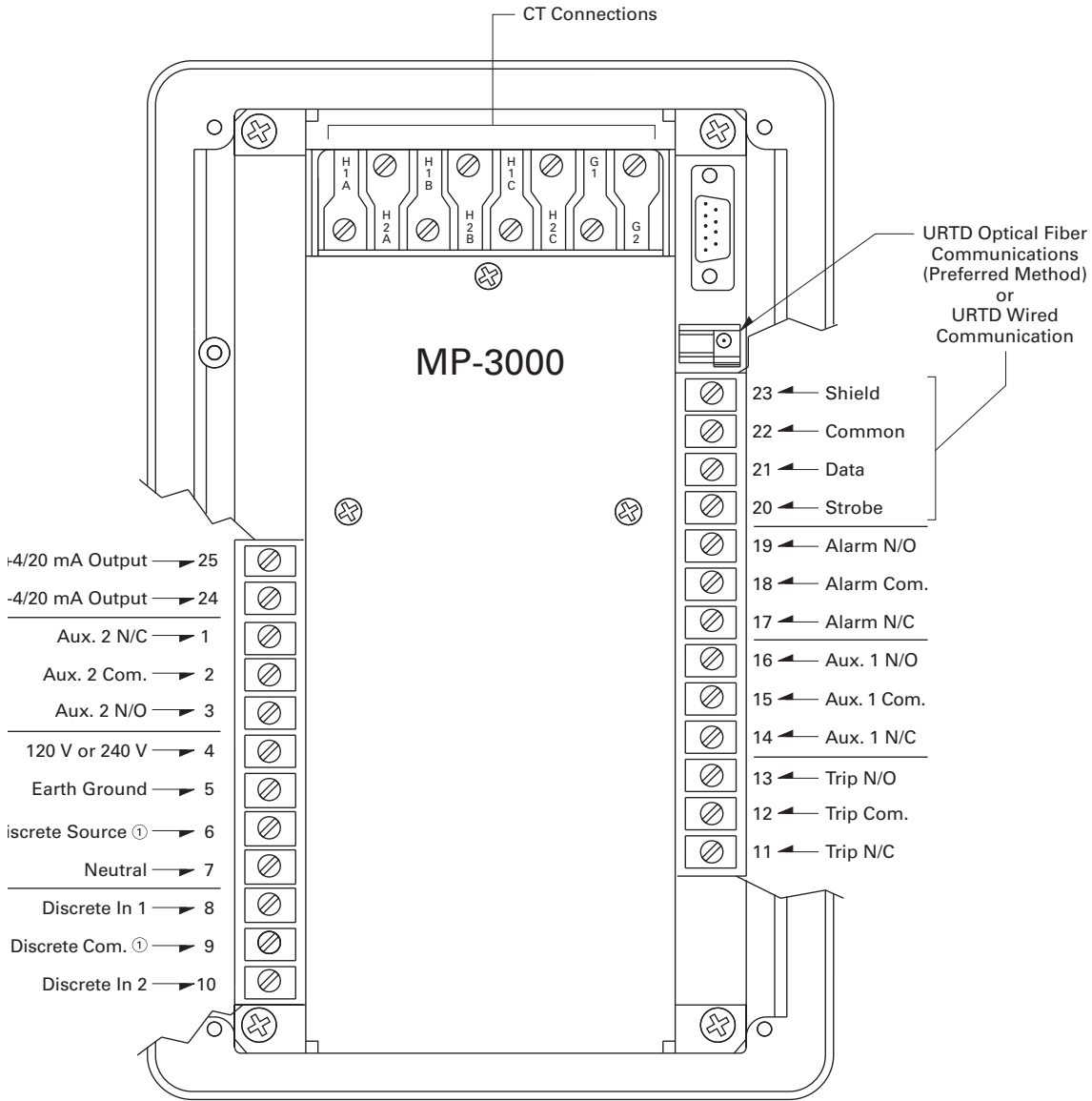

Note

① **Caution:** Do not connect terminals 6 and 9 together.

MP-3000 Control and URTD Wiring

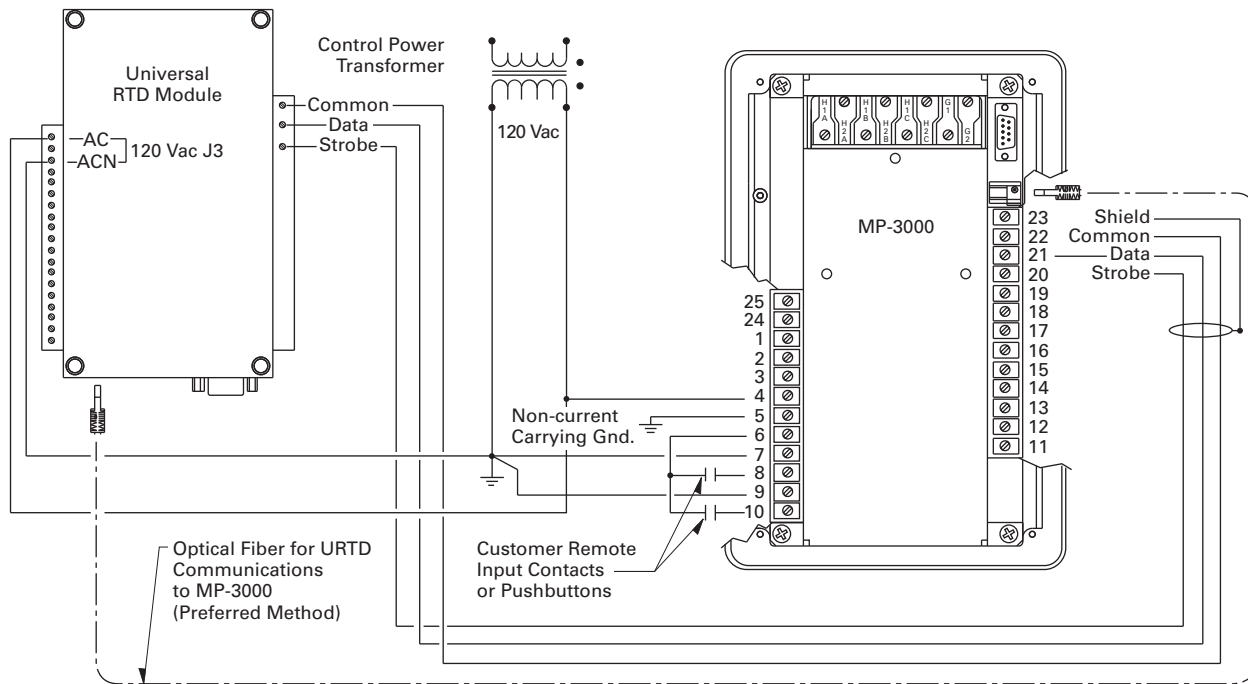

Trip Curve Chart

The MP-3000 motor relay records information on the most recent four starts. It records currents, percent of I^2t used, percent unbalance, RTD temperatures and time to transition and run. In addition, a motor start profile can be downloaded and displayed using Eaton's PowerPort or PowerNet Software. The starting profile shows the motor starting current plotted against the relay protection curve. This provides a quick view of the coordination between the protection and actual motor start current.

When communications are desired, an optional communication module or PONI (Product Operated Network Interface) is required. The MP-3000 is compatible with an INCOM (IPONI), Modbus RTU (MPONI) or Ethernet (EPONI). Future communication modules are planned to interface with other systems using other protocols. Please consult factory for availability of other communication options. **Page V3-T9-197** shows typical mounting of MP-3000 with optional PONI and with URTD module and PONI.

When the MP-3000 is supplied in the optional drawout case, then the INCOM (IPONI) is the only communication option available. The communication option must be selected at the time of order.

Motor Starting Profile Time/Current Chart

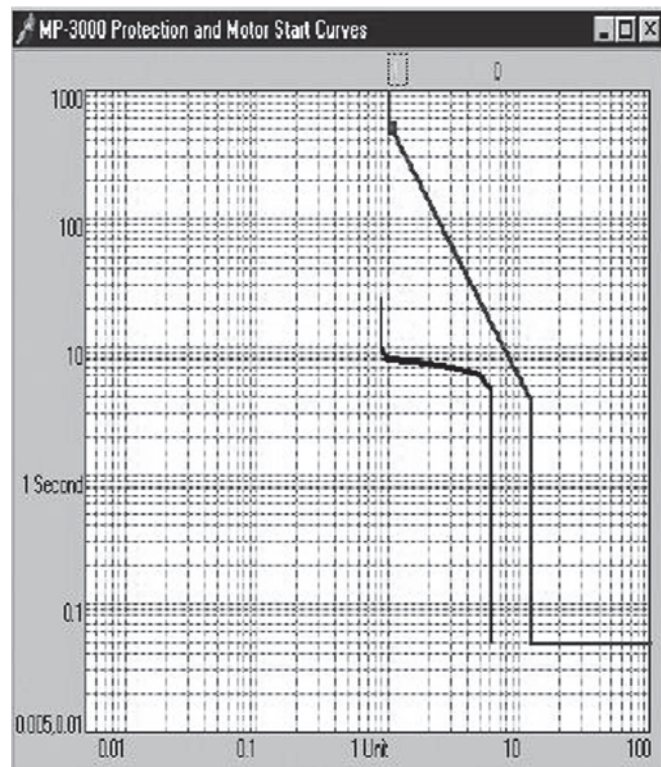

Dimensions

Approximate Dimensions in Inches (mm)

Panel Cutout Diagram

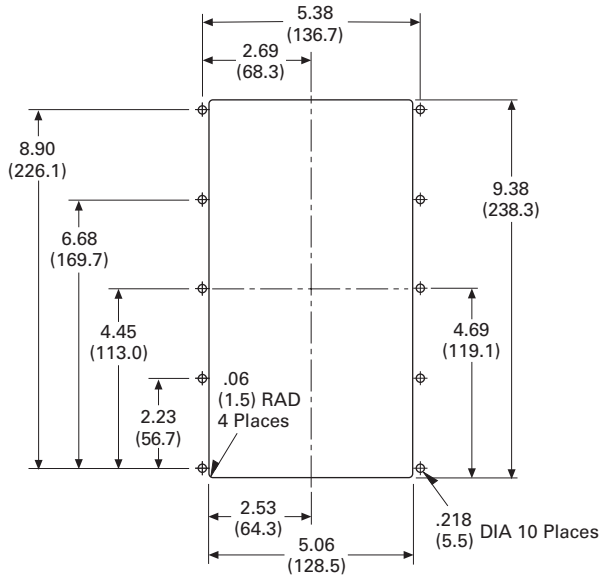

MP-3000 Drawout Panel Mounting

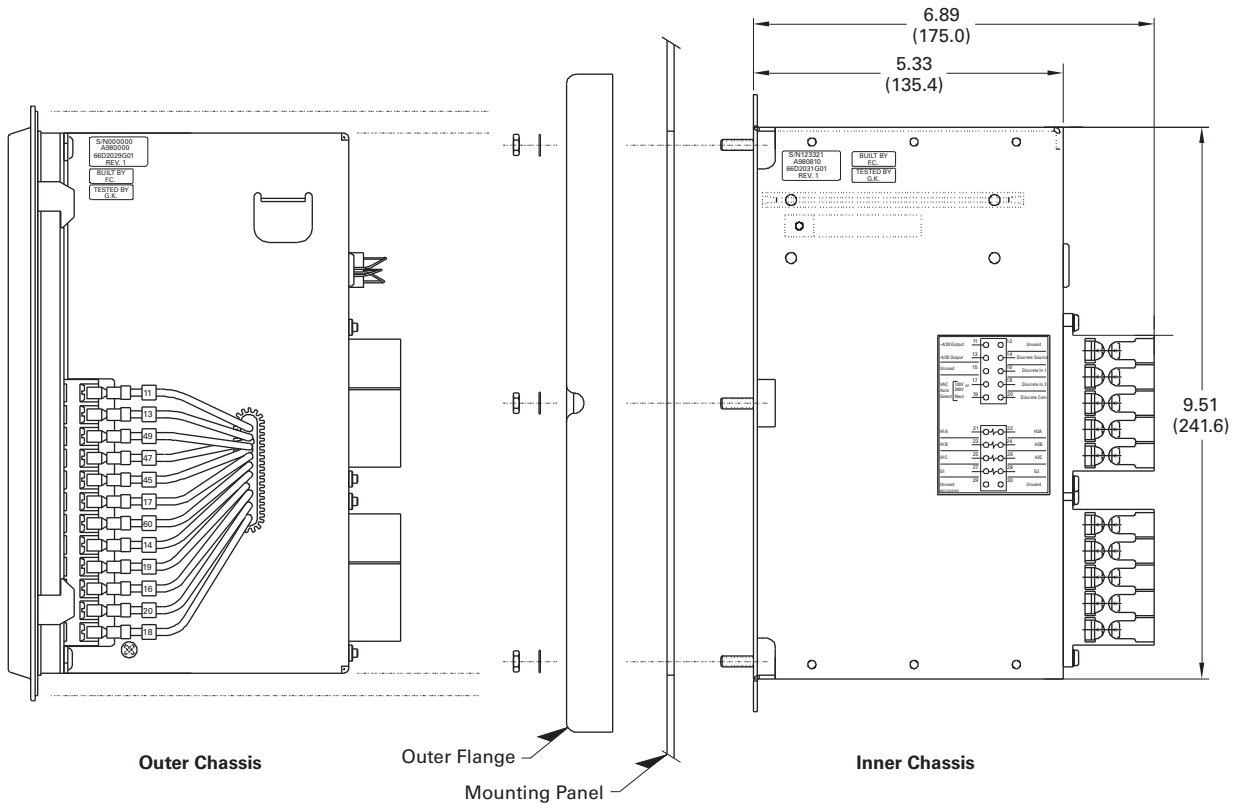

9.4

Metering Devices, Protective Relays, Software and Connectivity

Protective Relays

Approximate Dimensions in Inches (mm)

Rear View of MP-3000 Drawout Outer Case

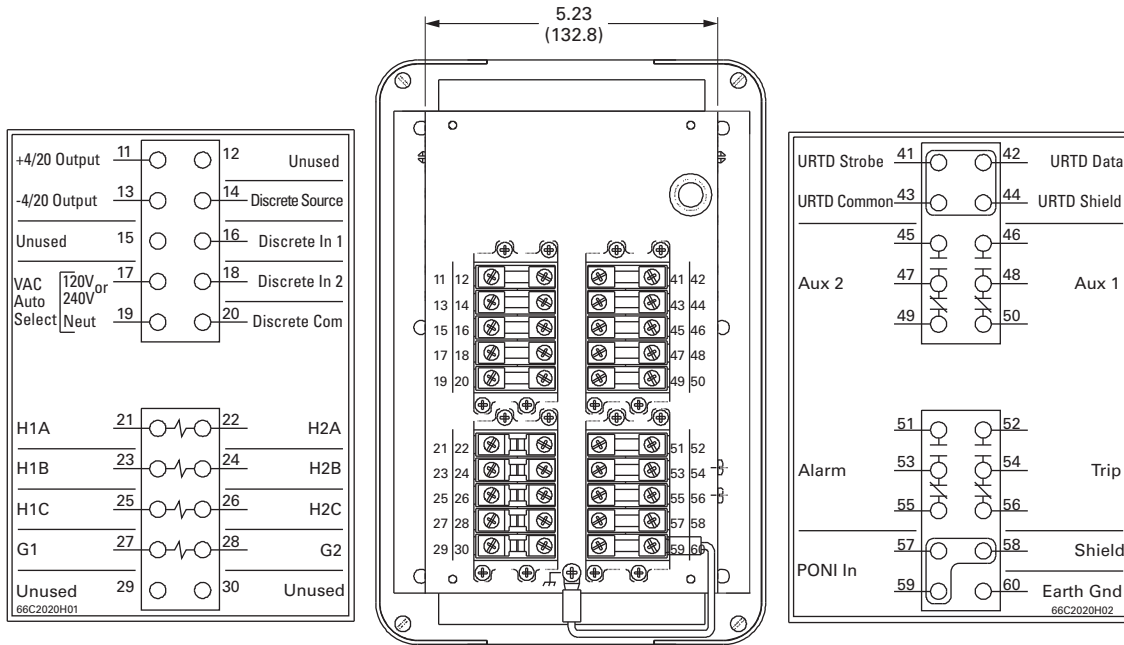

Approximate Dimensions in Inches (mm)

MP-3000 PONI and URTD Mounting

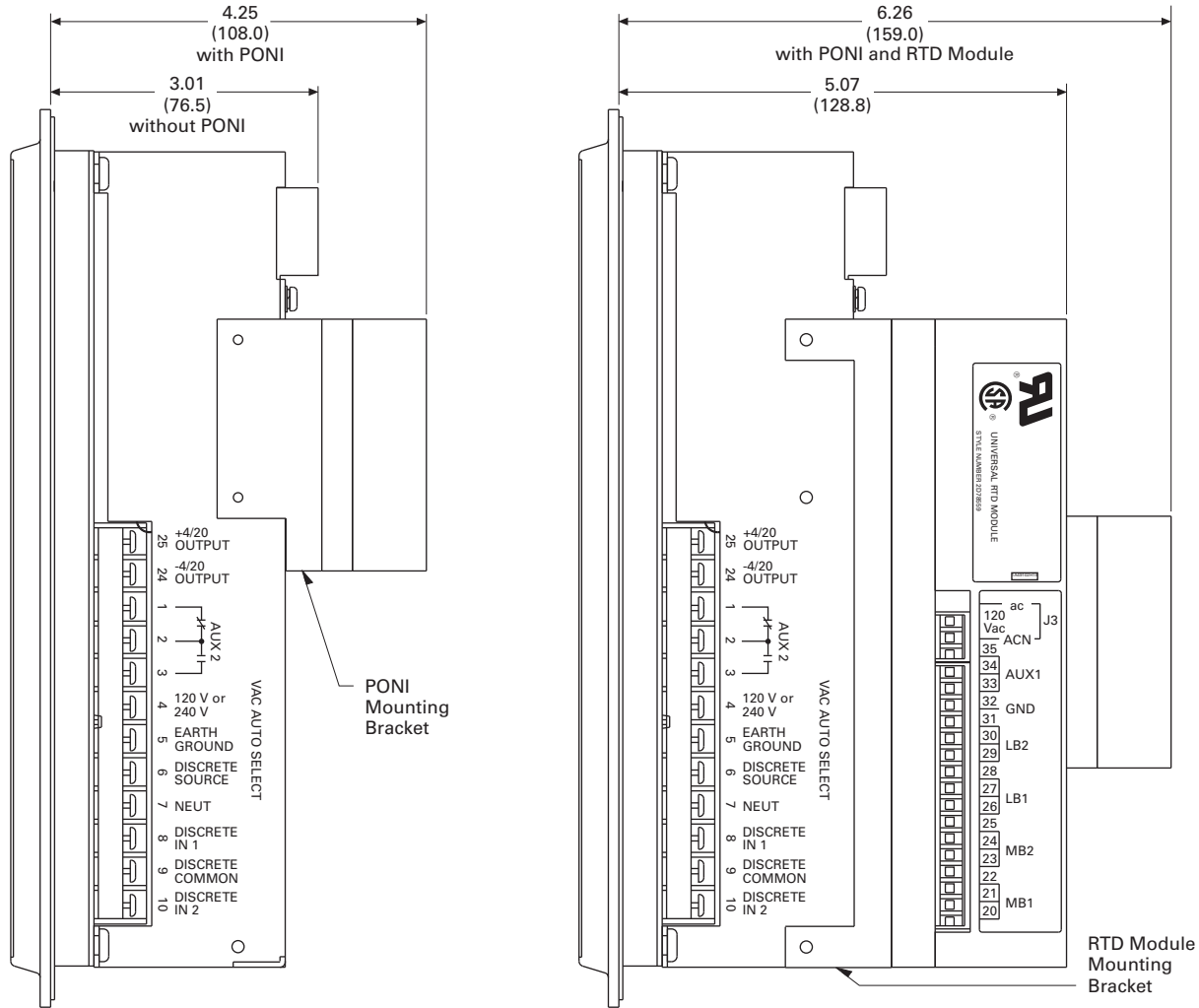

FP-3000 Feeder Protection Relay

Height	Width	Depth	Shipping Weight Lbs (kg)
10.25 (260.4)	6.72 (170.7)	3.70 (94.0)	7.0 (3.2)

MP-4000



MP-4000 Motor Protection

Product Description

- Microprocessor-based, multi-function motor protection
- Intel-I-Trip overload protection based on motor data
- Event recording and operational logging
- Motor Start Profile
- Optional Quick Release Drawout Case
- Used on AMPGARD and medium voltage assemblies
- “Help” menu provides user operational assistance

Application Description

Eaton’s MP-4000 motor protection relay is a multifunctional microprocessor-based protective relay for the protection of three-phase ac motors. The MP-4000 motor relay may be applied to any size motor at any voltage level. It is most commonly used on large, medium voltage three-phase induction motors. It has also been widely used on important low voltage (480 volt) motor applications and synchronous motors.

The MP-4000 motor relay monitors three-phase and ground currents, and three-phase voltages. It provides motor overload, stall, short circuit, phase unbalance, single phasing over/undervoltage, underpower, power factor and ground fault motor protection.

It can also be used to provide protection for a load jam or loss of load condition.

The MP-4000 motor relay provides start control logic to protect the motor against excessive starts or starting the motor before it has had

Contents

Description

	<i>Page</i>
Product Selection Guide	V3-T9-158
FP-6000 Feeder Protection	V3-T9-162
FP-5000 Feeder Protection	V3-T9-172
FP-4000 Feeder Protection	V3-T9-180
MP-3000 Motor Protection	V3-T9-188
MP-4000 Motor Protection	
Features, Benefits and Functions	V3-T9-199
Standards and Certifications	V3-T9-199
Product Selection	V3-T9-201
Options and Accessories	V3-T9-201
Technical Data and Specifications	V3-T9-202
Dimensions	V3-T9-203
MD-3000 Motor/Generator Differential Relay	V3-T9-204
Digitrip 3000	V3-T9-207
VR-300 Multifunctional Voltage Relay	V3-T9-217
DP-300 Current Differential Protection Relay	V3-T9-221
EDR-3000 Feeder Protection	V3-T9-226
ETR-4000 Transformer Protection Relay	V3-T9-237
Ground Fault Relay	V3-T9-250
Universal RTD Module	V3-T9-254
IQ 125 Volt DC Power Supply	V3-T9-258

sufficient time to cool down. The MP-4000 motor relay may be applied to either across the line starters or reduced voltage starters. On reduced voltage starters, the MP-4000 relay can control the switch from reduced voltage to full voltage based on time and/or motor transition. The MP-4000 can protect the starter against failure to transition to full voltage through contact feedback and an incomplete sequence function.

The MP-4000 motor relay is generally used on a motor starter or a breaker used for a motor load. The MP-4000 motor relay provides the intelligence to protect and control the motor against abnormal operating conditions. It monitors the currents from either a 5A or 1A secondary of a CT circuit. Ground current may be obtained from either a ground CT or from the residual connection of the phase CTs. It provides a form C contact output for controlling the starter contacts or breaker operation.

Features, Benefits and Functions

- Complete motor protection and control in a single compact case reduces panel space requirements and wiring costs
 - Microprocessor design with self diagnostics eliminates calibration and reduces installation, commissioning and maintenance
 - Programmable stop 2–20% of PCT
 - Intel-I-Trip overload protection develops customized curve from manufacturer's supplied motor data
 - Intel-I-Trip overload protection provides adaptive trip characteristics based on motor temperature when motor RTDs are connected through an optional URTD module
 - Meets UL 1053 ground fault protection standards that eliminates the need for a separate ground relay saving cost, space, wiring and time
 - Voltage dip/loss ride through capability reduces unnecessary trips caused by poor power quality
 - Motor currents, temperatures and conditions are monitored and displayed either locally or remotely
 - Event log provides motor operating records for the most recent 20 Trip or Alarm events with date and time stamping. This information can improve troubleshooting and reduce downtime
 - Log book records the most recent 100 events such as motor START/STOP and set point changes to provide a log of motor operation with date and time stamping
 - RTD diagnostics reduces unnecessary tripping caused by faulty RTD, RTD wiring or communications
 - Arm/Disarm feature improves security for critical motor applications
 - Motor Start profile verifies protection and motor starting coordination. This feature can be used to develop protection settings on old motors where data is not available
 - Optional communication module and Eaton's software simplifies setting, configuration, monitoring, commissioning and data retrieval either locally or remotely
 - Optional Quick Release Drawout Case construction simplifies relay removal and replacement
- The protection functions are listed below:
- I²t overload protection (49/51)
 - Locked rotor (49S/51)
 - Ultimate trip current (51)
 - Negative sequence phase unbalance (46)
 - Instantaneous overcurrent (50)
 - Ground fault protection (50G)
 - Undervoltage (27)
 - Overvoltage (59)
 - Under power (32)
 - Negative sequence voltage unbalance (47)
 - Power factor (55)
 - RTD trip and alarm with URTD module (49/38)
 - Underload trip (37)
 - Starts per time (66)
 - Jam or stall (51R)
 - Auto or manual reset (86)
 - Fail-safe or non-fail-safe trip modes

The metering functions are:

- Metering:
 - Average current
 - Amperes: magnitude and angle in primary values
 - Amperes: positive, negative and zero sequence
 - Average voltage (V ave)
 - Voltage: magnitude and angle
 - Voltage: positive, negative and zero sequence
 - % of full load
 - % current unbalance
 - % voltage unbalance
 - Power, vars and VA
 - Power factor
 - Frequency
 - Energy metering with time and date stamps
- RTD temperatures:
 - Individual winding
 - Motor bearing
 - Load
 - Auxiliary temperatures
- Motor conditions:
 - Percent of I²t thermal bucket
 - Time before start
 - Remaining starts allowed
 - Oldest start time

Standards and Certifications

The MP-4000 motor protection was designed to meet the industry standards for protective relays. It is recognized under UL 1053 Ground Fault Protection Standard.

- UL recognized (File No. E154862)
- UL 1053 recognized
- UL 508 recognized
- ANSI C37.90, C37.90.1
- cUL
- CSA



Reference Information

Cross-Reference

Westinghouse®/Cutler-Hammer

Eaton's Cutler-Hammer MP-3000 motor relay supersedes the Cutler-Hammer (formerly Westinghouse) IQ 1000 II motor relay and can replace the earlier IQ 1000 motor relay version sold under the Westinghouse name. The MP-3000 motor relay fits in the same cut out and provides the protection functions of these older models. The MP-3000 relay provides numerous enhancements and new features over the superseded

models. The most notable enhancements are UL 1053 ground fault protection certified, voltage loss ride through capability, data logging, communications features and the addition of a clock for date and time stamping of events.

GE Multilin™

GE Multilin has several product offerings for motor protection. The 269 PLUS is the equivalent model to the MP-3000 with optional URTD module. Eaton offers MP-

3000 value packs that include an MP-3000, PONI, URTD module and fiber optic cable at competitive prices.

GE Multilin has both lower and higher end products. The MP-3000 can be used in place of their 239 motor relay. The MP-3000 offers more capabilities than the 239 for a slightly higher price.

GE Multilin 369 and 469 are upgraded end products. The MP-3000 relay offers equivalent overload and current protection functions.

It also provides equivalent start control functions. Both the 369 and 469 offer voltage protection and metering functions. An Eaton meter and/or other manufacturers' protective relays may be needed to satisfy the customer's motor protection requirements. The 469 adds differential protection. This function must be supplied by others in addition to the MP-3000 motor relay.

Cross-Reference

New Eaton's Series	Old Cutler-Hammer (Westinghouse)	GE Multilin
MP-3000 (URTD module) ①	IQ 1000 II, IQ 1000	269, 269+, 239, base 369
MP-4000 (URTD module) ①	—	369 with voltage option
MP-4000 + MP-3000	—	469

Note

① If RTD monitoring required.

Product Selection

MP-4000



MP-4000 Ordering Information

Description	Catalog Number
MP-4000 drawout, 5A with RS-232	MP4011
MP-4000 drawout, INCOM, 5A with RS-232	MP4012
MP-4000 drawout, Modbus, 5A with RS-232	MP4013
MP-4000 drawout, DeviceNet, 5A with RS-232	MP4014
MP-4000 drawout, 1A with RS-232	MP4111
MP-4000 drawout, INCOM, 1A with RS-232	MP4112
MP-4000 drawout, Modbus, 1A with RS-232	MP4113
MP-4000 drawout, DeviceNet, 1A with RS-232	MP4114
MP-4000 fixed case, 5A with RS-232	MP4010
MP-4000 fixed case, INCOM, 5A with RS-232	MP4010INCOM
MP-4000 fixed case, Modbus, 5A with RS-232	MP4010MODBUS
MP-4000 fixed case, DeviceNet, 5A with RS-232	MP4010DEVICEN
MP-4000 fixed case, 1A with RS-232	MP4110
MP-4000 fixed case, INCOM, 1A with RS-232	MP4110INCOM
MP-4000 fixed case, Modbus, 1A with RS-232	MP4110MODBUS
MP-4000 fixed case, DeviceNet, 1A with RS-232	MP4110DEVICEN
MP-4000 fixed case, INCOM, 5A with RS-232, URTD	MP4010VPI
MP-4000 fixed case, Modbus, 5A with RS-232, URTD	MP4010VPM
MP-4000 fixed case, DeviceNet, 5A with RS-232, URTD	MP4010VPD
MP-4000 fixed case, INCOM, 1A with RS-232, URTD	MP4110VPI
MP-4000 fixed case, Modbus, 1A with RS-232, URTD	MP4110VPM
MP-4000 fixed case, DeviceNet, 1A with RS-232, URTD	MP4110VPD

Options and Accessories

Additional Related Products by Eaton's Cutler-Hammer Series

The MP-4000 is available in either a fixed mount or Quick Release Drawout Case. Both mountings use the same panel cutout.

The Universal RTD module (URTD) is required when the motor is equipped with RTDs that you wish to monitor and use for protection. The URTD can be mounted near the motor to reduce RTD wiring and costs.

The MP-4000 motor protection is design-ed to operate from 120 Vac or 240 Vac auxiliary control power. The MP-4000 motor relay can be used with dc control power with the addition of the IQDCPS. The IQDCPS is an inverter from DC to AC.

Technical Data and Specifications

Control Power

- Nominal rating:
 - 120 Vac or 240 Vac
 - +10%, -25%
- Operating range:
 - 120 Vac: 90 132 Vac
 - 240 Vac: 180 264 Vac
- Frequency: 50 or 60 Hz
- Power use:
 - 20 VA maximum
 - URTD: 6 VA maximum
 - IPONI: 1 VA maximum
- Ride-through time: 30 cycles from nominal Vac

Current Inputs

- Nominal (I_n): 1A or 5A
- CT rating:
 - 2 x I_n continuous
 - 50 x I_n for 1 second
- Burdens:
 - < 0.25 VA at 5A
 - < 0.05 VA at 1A

Voltage Inputs

- Nominal: 120 Vac
- Operating range: 69 to 150 Vac
- Burden: 2 VA

Metering Accuracy

- Phase current: $\pm 1\%$ of I_n (5–100%)
- Ground current: $\pm 1.5\%$ of I_n (0–55%)

Discrete Inputs

- Number of inputs: two programmable
- Ratings:
 - 1.2 VA at 120 Vac
 - Maximum off = 36 Vac
 - Minimum on = 86 Vac

Output Contacts

- Number of outputs: four Form C, programmable.
- Momentary:
 - Make 30A AC/DC for 0.25 seconds
 - Break 0.25A at 250 Vdc (Resistive)
 - Break 5A at 120 240 Vac
- Continuous:
 - 5A at 120/240 Vac
 - 5A at 30 Vdc

Analog Output

- Rating: ± 4 –20 mA programmable
- Maximum load: 1K ohm
- Accuracy: 1%

Motor Overload Protection (I^2t)

- Full load amperes: 10–3000
- Locked rotor current: 300–1200% FLA
- Locked rotor time: 1–120 seconds
- Ultimate trip current: 85–150% FLA
- Phase CT ratio: 10–4000 (I_n)
- Ground CT ratio: 10–4000 (I_n)
- Timing accuracy: $\pm 2.5\%$ or ± 30 mS for $I > 1.1x$ U.T.C.

Trip Setting Range

- Ground fault (GF): Off, 2–55% CT ratio
- GF start time delay: 2–60 cycles
- GF run time delay: 0–60 cycles
- Timer accuracy: ± 20 mS
- Instantaneous O.C.: Off, 300–1600% FLA
- IOC start time delay: 2–60 cycles
- Timer accuracy: ± 20 mS
- JAM trip: Off, 100–1200% FLA
- Underload trip: Off, 1–90% FLA
- Current unbalance trip: Off, 4–40% I_{neg}/I_{pos}
- Start delay timers:
 - 0–120 seconds (underload and phase unbalance)
 - 0–1200 seconds (jam)
- Run delay timers: 0–240 seconds
- Timer accuracy: $\pm 0.5\%$ +100 mS
- Voltage unbalance: Off, 1 to 100V
- % V2/V1: 4% + 40%
- Voltage unbalance time delay: 0 to 1200 sec.
- Under/overvoltage time delay: Off, 10 to 150V
- Under/overvoltage time delay: 0 to 1200 sec

- Under/overfrequency: Off, 15 to 60 Hz
- Under/overfrequency time delay: 0 to 60 sec
- Power protection: Off, 0.06 to .90 + FLA VT
- Power time delay: 0 to 1200 sec
- Power factor: Off, 0.05 lag to 0.99 lead
- Power factor time delay: 0 to 60 sec

Alarm Setting Range

- Ground fault: Off, 2–55% CT ratio
- Overload I^2t : Off, 60–99% I^2t
- JAM: Off, 100–1200% FLA
- Underload: Off, 1–90% FLA
- Phase unbalance: Off, 4–40% I_{neg}/I_{pos}
- Run delay timers: 0–240 seconds

Start Control Functions

- Starts per time: 1–10 starts
- Time for starts per time: Off, 1–240 minutes
- Time between starts: Off, 1–240 minutes
- Number of cold starts: 1–5 starts
- Motor transition current: 10–300% FLA
- Time for transition: 0–1200 seconds
- Inc. sequence timer: Off, 1–240 seconds
- Long acceleration timer: Off, 1–1200 seconds
- Anti-Backspin timer: Off, 1–3600 minutes

RTD Inputs (Requires URTD module)

- Sensor types:
 - 10 ohm copper
 - 100 ohm nickel
 - 120 ohm nickel
 - 100 ohm platinum

URTD Module Communications

- Interface:
 - Electrical (three-wire)
 - Fiber optic (preferred)
- Fiber optic cable: Type HBFER-ERS or EUS

Clock

- Accuracy: ± 1 minute/month at 77°F (25°C)

PONI Communications

- Type: two-wire, FSK
- Baud rate: 1200 or 9600 baud
- Protocol: INCOM
- Functions:
 - Read/write set points
 - Read metered values
 - Read trip/alarms
 - Read events/history
 - View starting profile

MPONI Communications

- Type: five-wire, 485
- Baud rate: 1200 or 9600 baud
- Protocol: Modbus RTU
- Functions:
 - Read metered values
 - Read trip/alarms

DPONI Communications

- Type: J-wire
- Baud rate: 500k, 250k, 125k
- Protocol: DeviceNet
- Functions:
 - Read metered values
 - Read trip/alarms

Logging

- Log book: 100 events
- Log event: 20 trips and alarms
- Log start: last four starts
- Start profile: last four starts (communication only)
- History records: motor, trips, alarms and total records

Environmental Conditions

- Operating temperature: -4°F to +140°F (-20°C to +60°C)
- Storage temperature: -49°F to +185°F (-45°C to +85°C)
- Humidity: 0–95% noncondensing

Dimensions

Approximate Dimensions in Inches (mm)

MP-4000 Feeder Protection Relay

Height	Width	Depth	Shipping Weight Lbs (kg)
10.25 (260.4)	6.72 (170.7)	3.70 (94.0)	7.0 (3.2)

MD-3000



MD-3000 Motor/Generator Differential Relay

Product Description

Eaton's MD-3000 Protective Relay is a microprocessor-based sensitive three-phase instantaneous OC-trip relay designed for both ANSI and IEC applications. The MD-3000 is suitable for use as a motor/generator differential relay.

The MD-3000 Relay operates from the 5 ampere secondary output of standard current transformers. Current transformer ratio information is quickly programmed into the unit via settings. The MD-3000 features a user-friendly operator panel to monitor, program and test the relay. Operating parameters and troubleshooting information are displayed in the two display windows.

Application Description

The MD-3000 microprocessor-based relay provides reliable instantaneous trip protection for all voltage levels. It is most commonly used as motor differential protection relay.

Features, Benefits and Functions

- ANSI or IEC applications
- Phase differential currents
- Monitoring and reporting of magnitude and phase of current causing trip
- Relay failure alarm contact
- Trip alarm contact
- User-friendly front panel
- Non-volatile memory
- View settings any time
- Set CT ratios
- Integral test mode (phase and ground)
- Program and test mode security access cover with meter seal provision
- Continuous internal circuitry self-testing
- Programmable lockout/self reset after trip

System Protection

- Instantaneous sensitive phase overcurrent trip
- Configurable trip outputs

Information and Data Delivery

- Displays current transformer ratio
- Data/information transmission

Contents

Description

	<i>Page</i>
Product Selection Guide	V3-T9-158
FP-6000 Feeder Protection	V3-T9-162
FP-5000 Feeder Protection	V3-T9-172
FP-4000 Feeder Protection	V3-T9-180
MP-3000 Motor Protection	V3-T9-188
MP-4000 Motor Protection	V3-T9-198
MD-3000 Motor/Generator Differential Relay	
Technical Data and Specifications	V3-T9-205
Dimensions	V3-T9-206
Digitrip 3000	V3-T9-207
VR-300 Multifunctional Voltage Relay	V3-T9-217
DP-300 Current Differential Protection Relay	V3-T9-221
EDR-3000 Feeder Protection	V3-T9-226
ETR-4000 Transformer Protection Relay	V3-T9-237
Ground Fault Relay	V3-T9-250
Universal RTD Module	V3-T9-254
IQ 125 Volt DC Power Supply	V3-T9-258

Standards and Certifications

- ANSI C37.90 (1989), C37.90.1 (1989), C37.90.2 (1995)
- IEC 255
- UL 1053



Product Selection

MD-3000



Catalog Numbers

Description	Catalog Number
Fixed Case	MD3000
Drawout Case	MD3001

Technical Data and Specifications

Product Specifications

Current Inputs

- CTs: 5A secondary
- CT burden:
 - <0.004 ohm at rated current (5A)
 - <0.1 VA at rated current (5A)
- I_n : 5A (Secondary) or CT (Primary)
- Saturation: $30 \times I_n$
- CT thermal ratings:
 - 10A continuous
 - 500A for 1 second

CT (Primary) Settings Available

- Phase: 5/10/25/50/75/100/150/200/250/300/400/500/600/630/800/1000/1200/1250/1500/1600/2000/2400 2500/3000/3200/4000/5000

Input Voltage

- Nominal:
 - 48–250 Vdc
 - 120–240 Vac 50/60 Hz
- Operating range:
 - 28–280 Vdc
 - 90–254 Vac 50/60 Hz

Power Consumption

24	48	125	250	120	240
Vdc	Vdc	Vdc	Vdc	Vac	Vac
10W	10W	10W	10W	10 VA	18 VA

Output Trip Contacts

- Momentary:
 - Make 30A AC/DC for 0.25 seconds
 - Break 0.25A at 250 Vdc
 - Break 5A at 120/240 Vac
- Continuous:
 - 5A at 120/240 Vac
 - 5A at 30 Vdc
 - Meets ANSI C37.90, Paragraph 6.7

Environmental Conditions

- Operating temperature: –22°F to +131°F (–30°C to +55°C)
- Operating humidity: 0–95% relative humidity (noncondensing)
- Storage temperature: –40°F to +158°F (–40°C to +70°C)

Auxiliary Alarm Contacts

- 5A continuous at 120/240 Vac, 30 Vdc
- 5A break at 120/240 Vac, 30 Vdc

Tests

- Dielectric strength, current inputs:
 - 3000 Vac for 1 minute
 - Phase-to-phase
- Seismic test: Meets requirements for UBC® and California Building Code Zone 4. ZPA = 3.5

Communications

- Eaton's PowerNet compatible
- Built-in INCOM
- Data rate is 1200 or 9600 baud

Drawout Case

- Refer to **Page V3-T9-215** for drawout case dimensions

Terminal Block

- Make/break rating:
 - 10A at 240 Vac nominal
 - 0.25A at 280 Vdc maximum
- Terminal wire gauge: No. 14 to No. 10 AWG
- Screw torque requirements: 18-inch-pounds

Wiring Diagrams

Self-Balancing Differential Protection

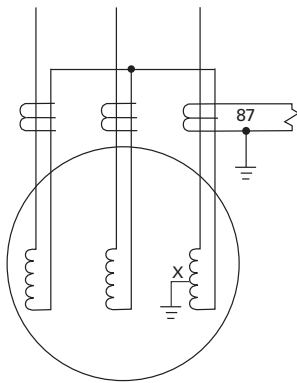

Conventional Phase Differential Protection

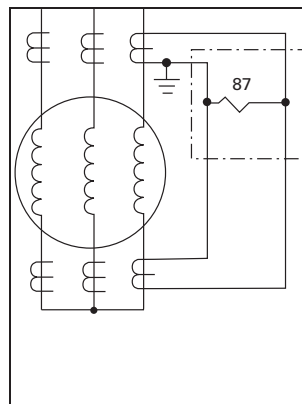

9.4

Metering Devices, Protective Relays, Software and Connectivity

Protective Relays

Dimensions

Approximate Dimensions in Inches (mm)

Drilling Pattern

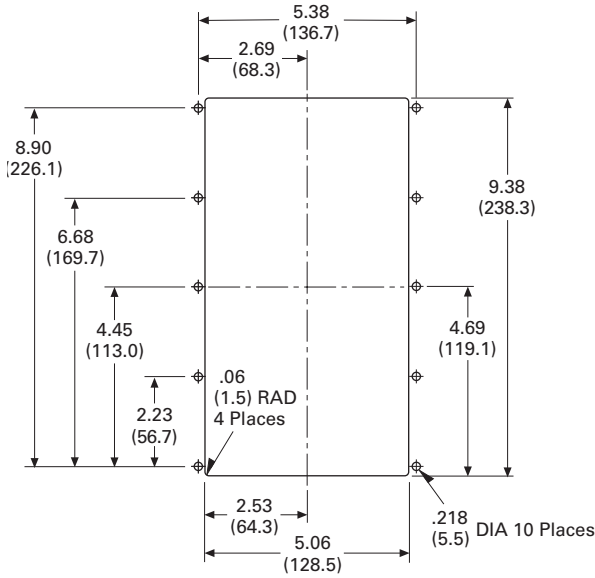

MD-3000

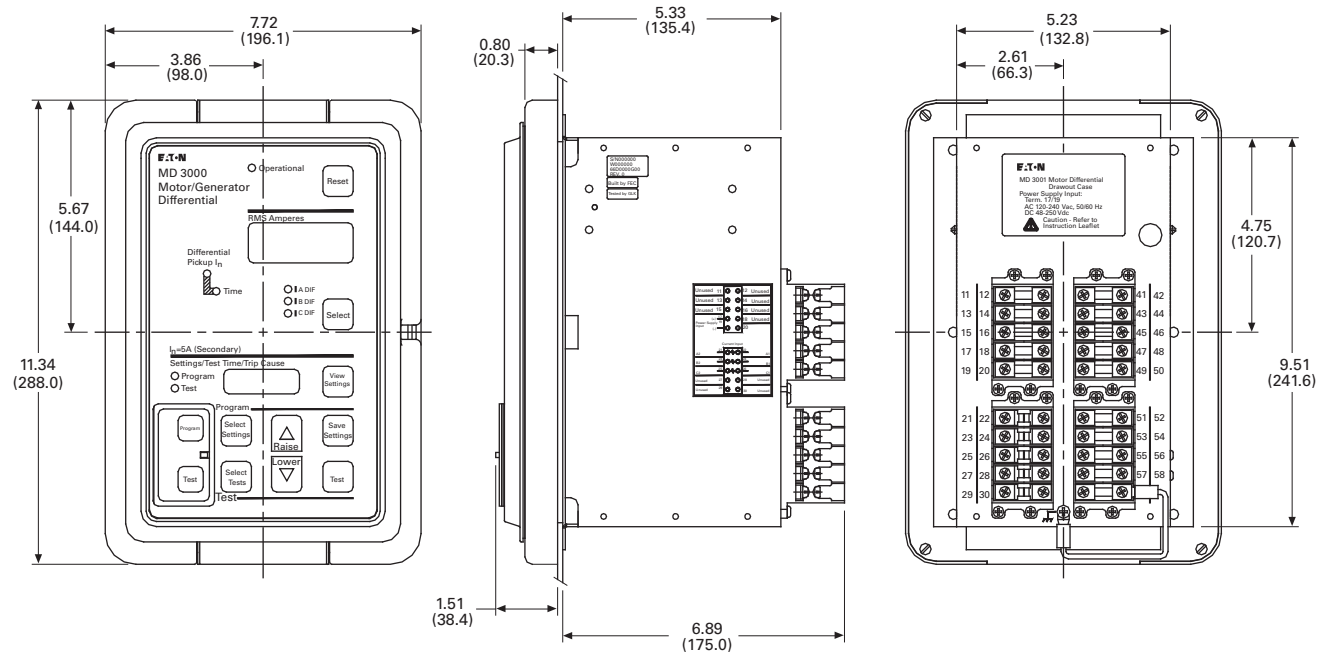

MD-3000 Feeder Protection Relay (Fixed Case)

Height	Width	Depth	Shipping Weight Lbs (kg)
10.25 (260.4)	6.72 (170.7)	3.70 (94.0)	7.0 (3.2)

DT-3000



Contents

<i>Description</i>	<i>Page</i>
Product Selection Guide	V3-T9-158
FP-6000 Feeder Protection	V3-T9-162
FP-5000 Feeder Protection	V3-T9-172
FP-4000 Feeder Protection	V3-T9-180
MP-3000 Motor Protection	V3-T9-188
MP-4000 Motor Protection	V3-T9-198
MD-3000 Motor/Generator Differential Relay	V3-T9-204
Digitrip 3000	
Features, Benefits and Functions	V3-T9-209
Standards and Certifications	V3-T9-209
Product Selection	V3-T9-210
Options and Accessories	V3-T9-210
Technical Data and Specifications	V3-T9-211
Dimensions	V3-T9-214
VR-300 Multifunctional Voltage Relay	V3-T9-217
DP-300 Current Differential Protection Relay	V3-T9-221
EDR-3000 Feeder Protection	V3-T9-226
ETR-4000 Transformer Protection Relay	V3-T9-237
Ground Fault Relay	V3-T9-250
Universal RTD Module	V3-T9-254
IQ 125 Volt DC Power Supply	V3-T9-258

Digitrip 3000

Product Description

- Microprocessor-based, three-phase and ground overcurrent relay
- Independent phase and ground measuring circuits and operation
- Inverse time (51), short delay (50, 2) and instantaneous (50) protection
- Eleven time overcurrent characters including ANSI, IEC and thermal protection curves
- Phase and ground ammeter and peak demand functions
- INCOM communication port
- Fixed mount or optional quick release drawout case design
- Dual-source power supply option for AC control power applications

Application Description

Eaton’s Digitrip 3000 microprocessor-based relay provides reliable three-phase and ground overcurrent protection for all voltage levels. It can be used for

any application where instantaneous and/or time overcurrent protection is required. It is most commonly used as primary feeder circuit protection, see figure below.

Primary Feeder Circuit Protection

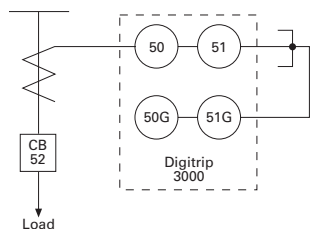

The Digitrip 3000 may be applied as the transformer primary protection or as backup to the differential protection, see figure below.

Transformer Overcurrent Protection

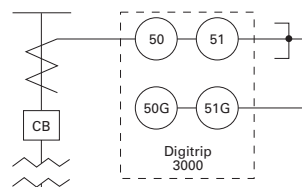

The Digitrip 3000 may be connected to the secondary side of a delta-wye grounded transformer with the ground element connected to a separate CT in the neutral connection of the transformer. With this connection, a lower CT ratio and a pickup setting can be used to provide more sensitive ground fault protection especially for resistance grounded systems, see figure below.

Transformer Secondary Protection with Neutral CT Connection

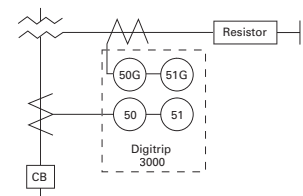

The Digitrip 3000 ground overcurrent element can be connected in the residual circuit of the phase CTs as shown in the top figure or to a separate ground CT as shown in last figure.

Residual Ground Connection

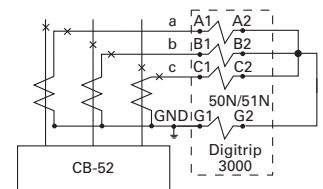

Separate Zero Sequence Ground CT Connection

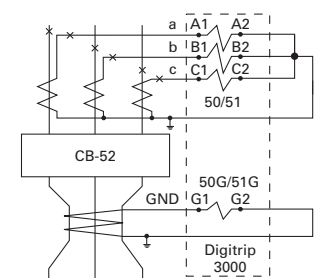

Zone Selective Interlocking (Phase and Ground)

Note: For the phase time overcurrent element, the current sensed by the Digitrip 3000 must exceed 300% ($3 \times I_n$) for the zone selective interlocking to initiate an immediate trip signal.

Zone Selective interlocking is a protection function to minimize equipment damage resulting from a phase or a ground fault in an area where long-time and/or short-time delay is in use.

When the “Ground Zone Interlocking” feature is utilized, an immediate trip is initiated when the fault is in the breaker’s zone of protection, regardless of its preset time delay. When the “Phase Zone Interlocking” feature is utilized, the time overcurrent and short delay phase elements work as follows. The short delay phase element will initiate an immediate trip when the fault is in the breaker’s zone of protection, regardless of its preset time delay. For the time overcurrent phase element, the current sensed by the Digitrip 3000 must exceed 300% ($3 \times I_n$) for the

zone selective interlocking to initiate an immediate trip signal when the fault is in the breaker’s zone of protection.

Upstream Digitrip 3000 protected breakers are restrained from tripping immediately by an interlocking signal from the downstream Digitrip 3000 relay. This interlocking signal requires only a pair of wires from the downstream breaker to the upstream breaker. The Upstream Digitrip 3000 provides time delayed standard coordinated tripping when the fault is located outside the zone of protection.

In the sample zone interlocking system shown below, circuit breakers A, B and C are equipped with Digitrip 3000 overcurrent relays.

Fault Location Zone 3

Note: For the phase time overcurrent element, the current sensed by the Digitrip 3000 must exceed 300% ($3 \times I_n$) for the zone selective interlocking to initiate an immediate trip signal.

If a fault occurs at a point in Zone 3, the Digitrip 3000 of Downstream Breaker C senses the fault and sends a restraining signal to the upstream Digitrip 3000 of Feeder Breaker B.

Having received this signal, the Digitrip 3000 of Feeder Breaker B begins timing for normal final delay tripping. As a result, only Downstream Breaker C is tripped.

Fault Location Zone 2

Note: For the phase time overcurrent element, the current sensed by the Digitrip 3000 must exceed 300% ($3 \times I_n$) for the zone selective interlocking to initiate an immediate trip signal.

If a fault occurs at a point in Zone 2, the Digitrip 3000 of Feeder Breaker B senses the fault and sends a restraining signal to the upstream Digitrip 3000 of Main Breaker A.

The Digitrip 3000 of the Downstream Breaker C does not see this fault since it is situated on the downstream side of the fault. As a result,

the Digitrip 3000 of Downstream Breaker C does not send a restraining signal to the Digitrip 3000 of Feeder Breaker B.

Since there is no restraining signal from the Digitrip 3000 of Downstream Breaker C, the Digitrip 3000 of Feeder Breaker B identifies that the fault is in Zone 2 and immediately trips Feeder Breaker B, regardless of its time setting.

Fault Location Zone 1

Note: For the phase time overcurrent element, the current sensed by the Digitrip 3000 must exceed 300% ($3 \times I_n$) for the zone selective interlocking to initiate an immediate trip signal.

If a fault occurs in Zone 1, no restraining signal is received by the Digitrip of Main Breaker A. As a result, Main Breaker A is immediately tripped by its Digitrip overcurrent relay, regardless of its time setting.

Sample Zone Selective Interlocking System

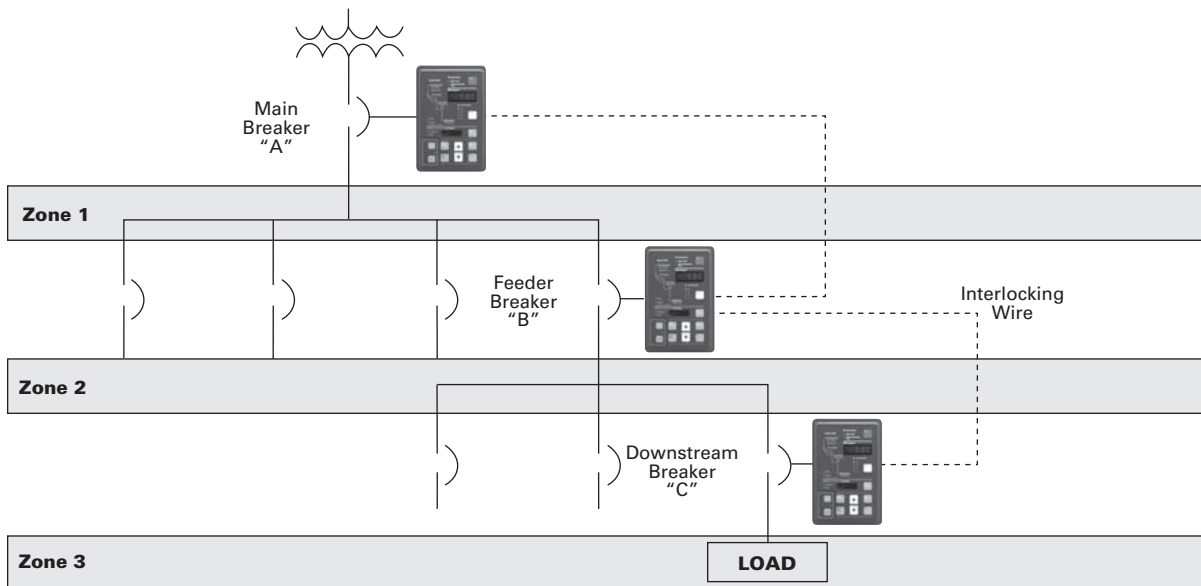

Features, Benefits and Functions

- Complete current protection and metering in a single compact case reduces panel space, wiring and cost
- Selectable trip characteristics simplify ordering and reduces inventory
- Optional drawout case provides easy and quick removal and replacement of the relay
- Optional dual-source power supply provides reliable protection when applied with ac control power, eliminating the need for batteries or UPS
- Integral ampmeter and display replaces separate meter and switch, saving panel space, wiring and money
- Zone selective interlocking improves coordination and tripping times and can save money by using in place of traditional bus differential
- Integral test function and microprocessor design can reduce maintenance time and expense

Standards and Certifications

- UL recognized
- UL 1053 recognized
- ANSI C37.90
- ANSI C37.90.1 (1989)
- ANSI C37.90.2 (1995)

Note: Fixed case versions meet 35V/m. Drawout case versions meet 28V/m.

- IEC 255
- CE (DT3030/3031 version only)



Product Selection

DT-3000

DT-3000



Description	Catalog Number
DT-3000 protective relay	DT3000
DT-3000 protective relay Chicago version	DT3100
DT-3030 protective relay (24–48 Vdc CE Mark version)	DT3030
DT-3000 drawout case protective relay	DT3001
DT-3000 Chicago version drawout case protective relay	DT3101
DT-3030 drawout case protective relay (24–48 Vdc CE Mark version)	DT3031
DT-3000 protective relay with 120 Vac dual-source power supply	DT3010
DT-3000 protective relay with 240 Vac dual-source power supply	DT3020

9

Options and Accessories

Additional Products by Eaton's Cutler-Hammer Series

Dual-Source Power Supply Option

The Digitrip 3000 with Dual-Source Power Supply (DSPS) is available in two versions, DT-3010 and DT-3020. They include an integral power supply module that:

- Powers the relay from nominal 120 Vac, 50/60 Hz (DT-3010 model) or 240 Vac, 50/60 Hz (DT-3020 model) auxiliary power, which is normally connected and available.
- Operates solely from the main current transformers (CTs) during a fault if the normally connected auxiliary ac voltage is not available, like an electromechanical relay or an electronic "self-powered" relay.

Functional Description

The integral Dual-Source Power Supply (DSPS) contains one AC voltage transformer and three AC current transformers. The AC voltage transformer is used to supply nominal ac control power to the unit. The current transformers are used to power the unit from the line current. Normally, the unit will operate from the AC auxiliary voltage.

Because this voltage is usually obtained from the system containing the circuit that the relay is protecting, a fault on the protected line could cause the AC voltage to drop below an acceptable operating level. Below approximately 70 volts for DT-3010 or 140 volts for DT-3020, the DSPS switches over to current powering.

All three current transformer secondaries are connected in series to supply this power. The DSPS will supply enough power to operate the Digitrip 3000 overcurrent relay in the tripped state with currents greater than 1.8 per unit rated secondary current, or 9A, in a single-phase. The DSPS will operate with three-phase currents in a tripped state with currents greater than 1.2 per unit or 6A rated secondary current.

Note: There will be no effect to the DT-3000 relay trip time accuracy when the Dual-Source Power Supply switches from normal ac voltage to fault-current power.

Burden Data

In normal operating conditions, the burden is <0.08 ohms with three-phase 1A CT current, or 0.2 per unit, and drops to less than 0.04 ohms at high current levels. Present CT burden data in ohms and volt-amperes, see **Page V3-T9-212**.

In these cases, the burden shown is the total CT terminal value, which is the DSPS plus the relay measuring circuits, for the indicated operating condition.

The trip curve on **Page V3-T9-212**, right, shows burden impedance magnitude in ohms. The two lower curves are the values with AC power applied; the upper two are with CT powering only. For each of these pairs, one curve shows the burden for a single-phase current (representing a single-phase-to-ground fault) and the other for three balanced phases with normally arrayed 120-degree phase angle increments. There is no phase sequence sensitivity.

Page V3-T9-212, trip curve, upper left, shows the burden in volt-amperes for the same four cases.

Digitrip 3000 Optional Drawout Case

The Digitrip 3000 overcurrent protective relay is available in a new drawout case for quick release, removal and replacement of the unit without disruption of the wiring. The CT circuits are self-shortening to prevent damaging voltages from existing across-the-current transformer windings. All voltage inputs, discrete inputs and contact inputs are disconnected while maintaining security against false tripping.

The terminal blocks feature a two-stage disconnect operation. Removal of the DT-3000 Inner Chassis will disconnect the trip circuits and short the CT secondaries before the unit control power is disconnected. Upon insertion of the Inner Chassis, the control power connections are made before the trip circuits are activated.

This feature provides added security against false tripping.

Technical Data and Specifications

Current Inputs

- CTs: 5A secondary
- CT Burden:
 - <0.004 ohm at rated current (5A)
 - <0.1 VA at rated current (5A)
 - I_n : 5A (Secondary) or CT (Primary)
- Saturation: 30 x I_n
- CT thermal ratings:
 - 10A continuous
 - 500A for 1 second

CT (Primary) Settings Available

- Phase and ground: 5/10/25/50/75/100/150/200/250/300/400/500/600/630/800/1000/1200/1250/1500/1600/2000/2400 2500/3000/3200/4000/5000

Input Voltage DT-300X

- Nominal:
 - 48–250 Vdc
 - 120–240 Vac 50/60 Hz
- Operating range:
 - 28–280 Vdc
 - 90–254 Vac 50/60 Hz

Power Consumption

	24	48	125	250	120	240
Vdc	Vdc	Vdc	Vdc	Vac	Vac	
10W	10W	10W	10W	10 VA	18 VA	

Input Voltage Digitrip 3030/3031

Description	DT-3010	DT-3020
Nominal	120 Vac	240 Vac
Operating Range	70–132 Vac	140–264 Vac
Power Consumption	15 VA	15 VA

Output Trip Contacts (Trip OC/Comm., Trip Inst. and Comm. Close)

- Momentary:
 - Make 30A AC/DC for 0.25 seconds
 - Break 0.25A at 250 Vdc
 - Break 5A at 120/240 Vac
- Continuous:
 - 5A at 120/240 Vac
 - 5A at 30 Vdc
 - Meets ANSI C37.90, Paragraph 6.7

Environmental Conditions

- Operating temperature: –22°F to +131°F (–30°C to +55°C)
- Operating humidity: 0–95% relative humidity (noncondensing)
- Storage temperature: –40°F to +185°F (–40°C to +70°C)

Auxiliary Alarm Contacts

- 5A continuous at 120/240 Vac, 30 Vdc
- 5A break at 120/240 Vac, 30 Vdc

Tests

- Dielectric strength, current inputs:
 - 3000 Vac for 1 minute
 - Phase-to-phase
- Seismic test: Meets requirements for UBC® and California Building Code Zone 4. ZPA = 3.5

Phase and Ground Time-Current Curves

- Thermal:
 - It (Moderately Inverse)
 - I^2t (Very Inverse)
 - I^4t (Extremely Inverse)
 - FLAT (Definite Time)
- ANSI (Per ANSI C37.112, 1996):
 - Moderately Inverse
 - Very Inverse
 - Extremely Inverse

- IEC (Per IEC 255-3, 1989):
 - IEC-A (Moderately Inverse)
 - IEC-B (Very Inverse)
 - IEC-C (Extremely Inverse)
 - IEC-D (Definite Time)

Overcurrent Functions and Pickup Ranges

Note: Consult factory for sensitive ground fault.

- Long Delay or Inverse Time Overcurrent:
 - Phase: (0.2–2.2) x I_n (29 settings)
 - Ground: (0.1–2.0) x I_n , None (26 settings)
- Short Delay:
 - Phase: (1–11) x I_n , None (25 settings)
 - Ground: (0.1–11) x I_n , None (45 settings)
- Instantaneous:
 - Phase: (1–25) x I_n , None (30 settings)
 - Ground: (0.5–11) x I_n , None (33 settings)

Time Delay Settings

- Inverse Time Overcurrent Time Multiplier:
 - Thermal: 0.2–40 (47 settings)
 - FLAT: 0.2–2 (21 settings)
 - ANSI (all): 0.1–5.0 (50 settings)
 - IEC (all): 0.05–1.00 (20 settings)
- Short Delay Time: 0.05–1.5 seconds (22 settings)

Current Monitoring

Note: Consult factory for sensitive ground fault.

- True rms sensing: three-phase and ground
- Display accuracy:
 - ±1% of Full Scale [I_n] from 0.04 x I_n to 1 x I_n
 - ±2% of Full Scale [I_n] from 1 x I_n to 2 x I_n
- Ampere demand: Average demand over 5 minute sampling window
- High load (with selectable output): 85% of Inverse Time Overcurrent setting

Timing Accuracy

- Inverse Time Overcurrent: ±10% at >1.5 x Pickup
- Short Delay Time: ±50 mS

Communications

- Eaton's PowerNet Compatible
- Built-in INCOM
- Data rate is 1200 or 9600 baud

Drawout Case

- Refer to **Page V3-T9-215** for Drawout Case Dimensions

Terminal Block

- Make/Break rating:
 - 10A at 240 Vac nominal
 - 0.25A at 280 Vdc maximum
- Terminal wire gauge: No. 14 to No. 10 AWG
- Screw torque requirements: 18-inch-pounds

Reference Information

Cross-Reference

There are several products that are equivalent to the Digitrip 3000. The following lists the competitor's name and equivalent product to the Digitrip 3000. In general, the Digitrip 3000 can be used in place of the competitive product.

- ABB® MMCO, 51
- Basler Electric® BEI-51
- GE Multilin MDP, 735, 737
- Siemens® 7SJ 511, 7SJ 60

Trip Curve Charts

Digitrip 3000 With Dual-Source Power Supply Burden Curves

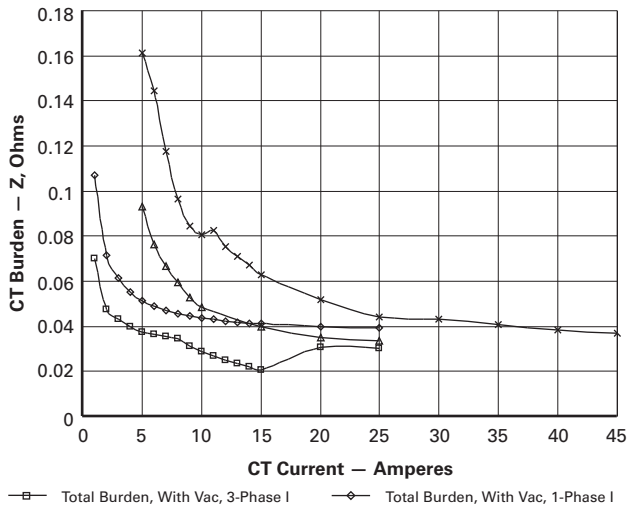

Digitrip 3000 With Dual-Source Power Supply CT Power Volt-Ampere Curves

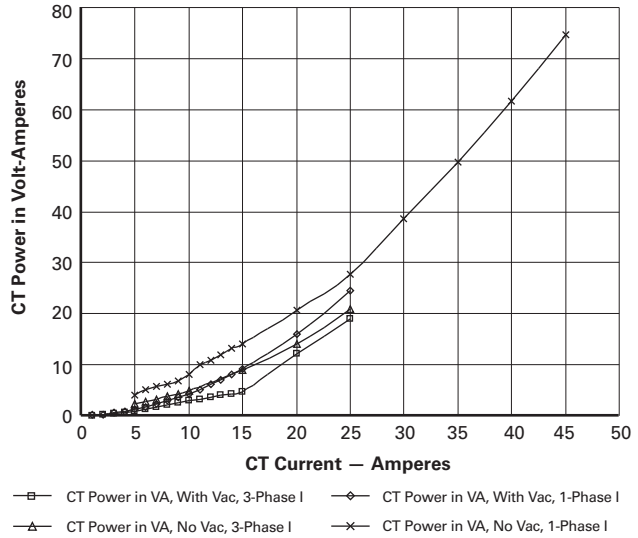

Wiring Diagrams

Digitrip 3001

Typical wiring diagram for the fixed mount version.

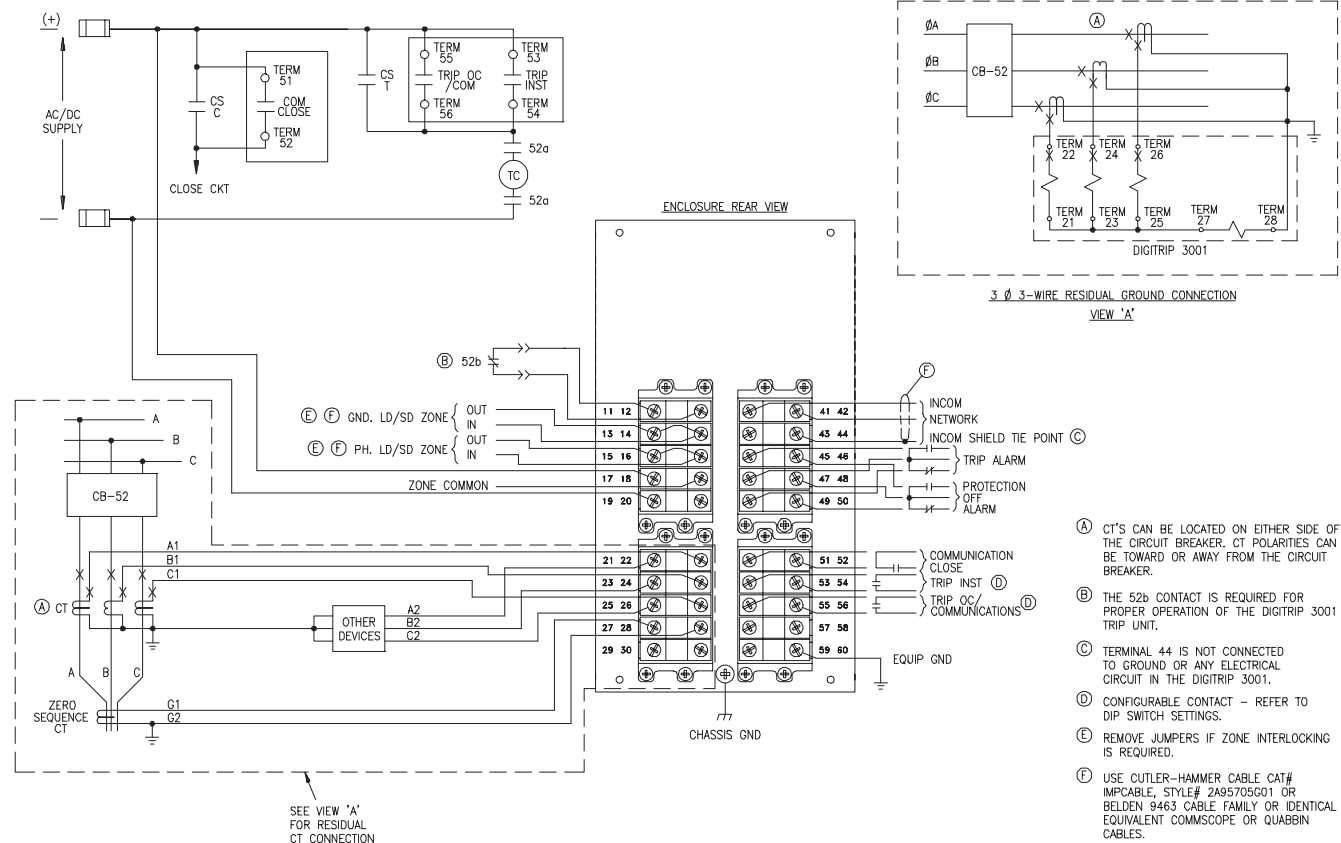

Digitrip 3000 Typical Wiring System

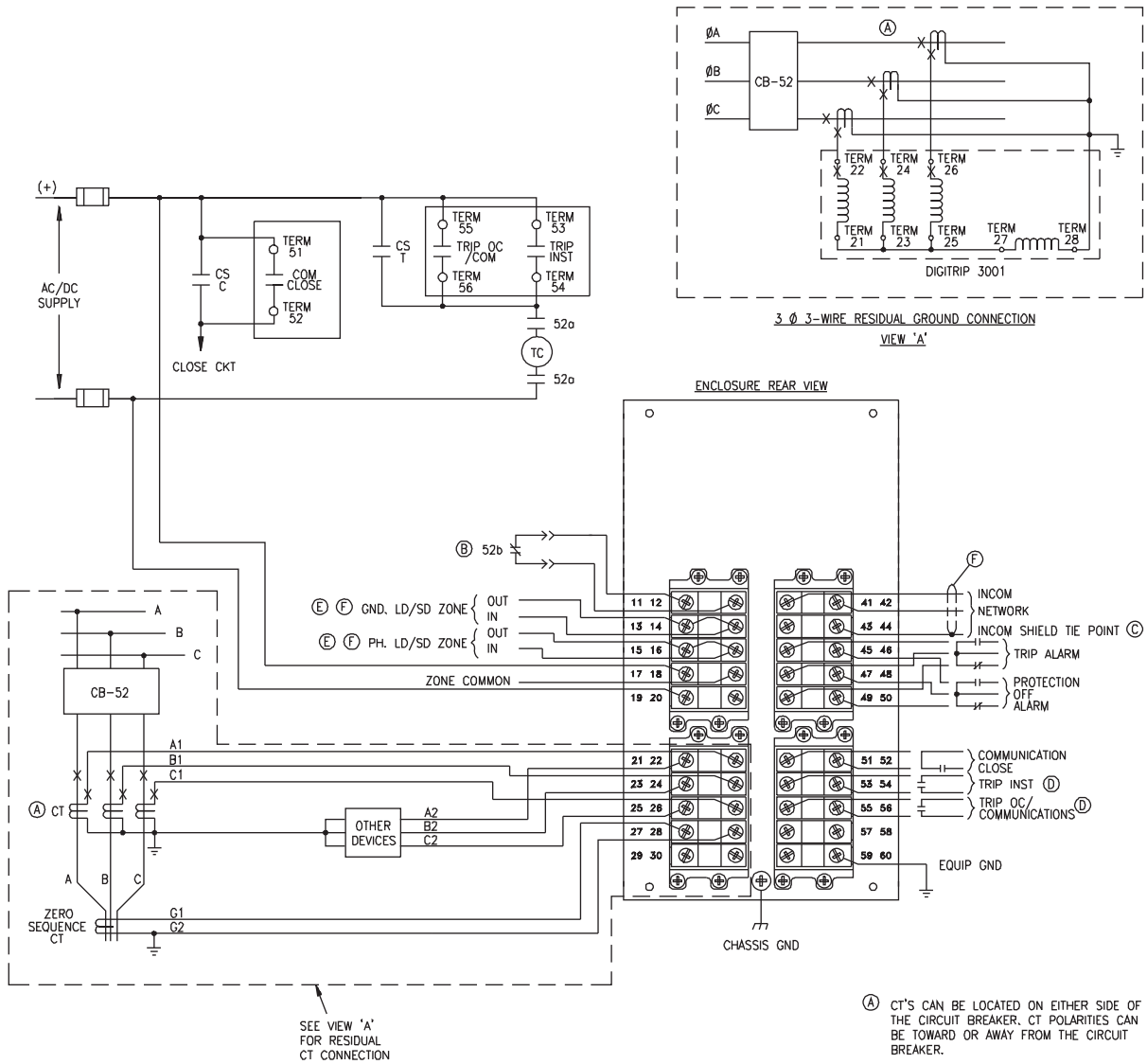

- (A) CT'S CAN BE LOCATED ON EITHER SIDE OF THE CIRCUIT BREAKER. CT POLARITIES CAN BE TOWARD OR AWAY FROM THE CIRCUIT BREAKER.
- (B) THE 52b CONTACT IS REQUIRED FOR PROPER OPERATION OF THE DIGITRIP 3001 TRIP UNIT.
- (C) TERMINAL 44 IS NOT CONNECTED TO GROUND OR ANY ELECTRICAL CIRCUIT IN THE DIGITRIP 3001.
- (D) CONFIGURABLE CONTACT - REFER TO DIP SWITCH SETTINGS.
- (E) REMOVE JUMPERS IF ZONE INTERLOCKING IS REQUIRED.
- (F) USE CUTLER-HAMMER CABLE CAT# IMPCABLE, STYLE# 2A95705G01 OR BELDEN 9463 CABLE FAMILY OR IDENTICAL EQUIVALENT COMMSCOPE OR QUABBIN CABLES.

Digitrip 3000 Typical Wiring Diagram

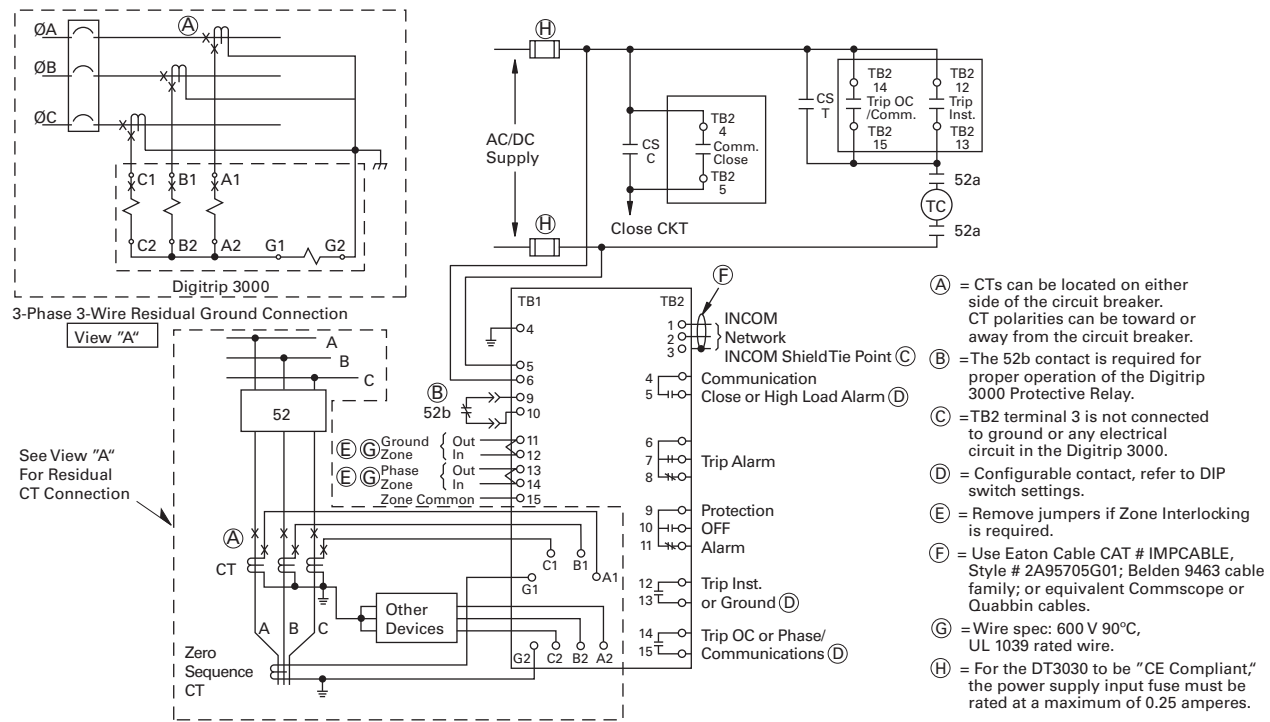

9

Dimensions

Approximate Dimensions in Inches (mm)

Drilling Pattern

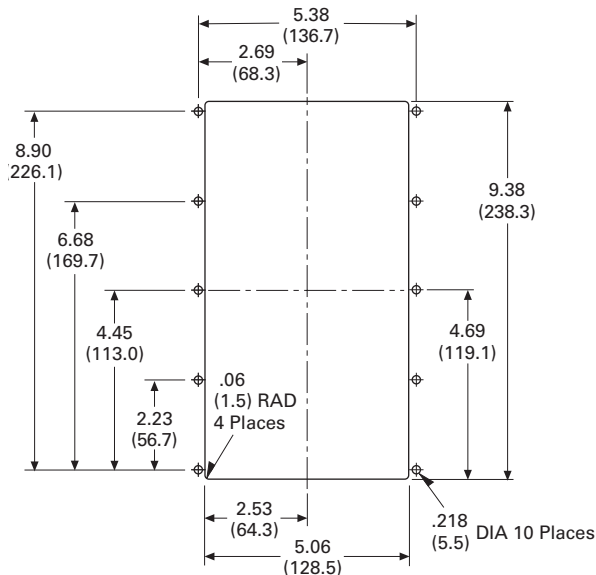

Note

Panel cutout dimensions for all versions of the Digitrip 3000 relay.

Approximate Dimensions in Inches (mm)

Digitrip 3010/3020

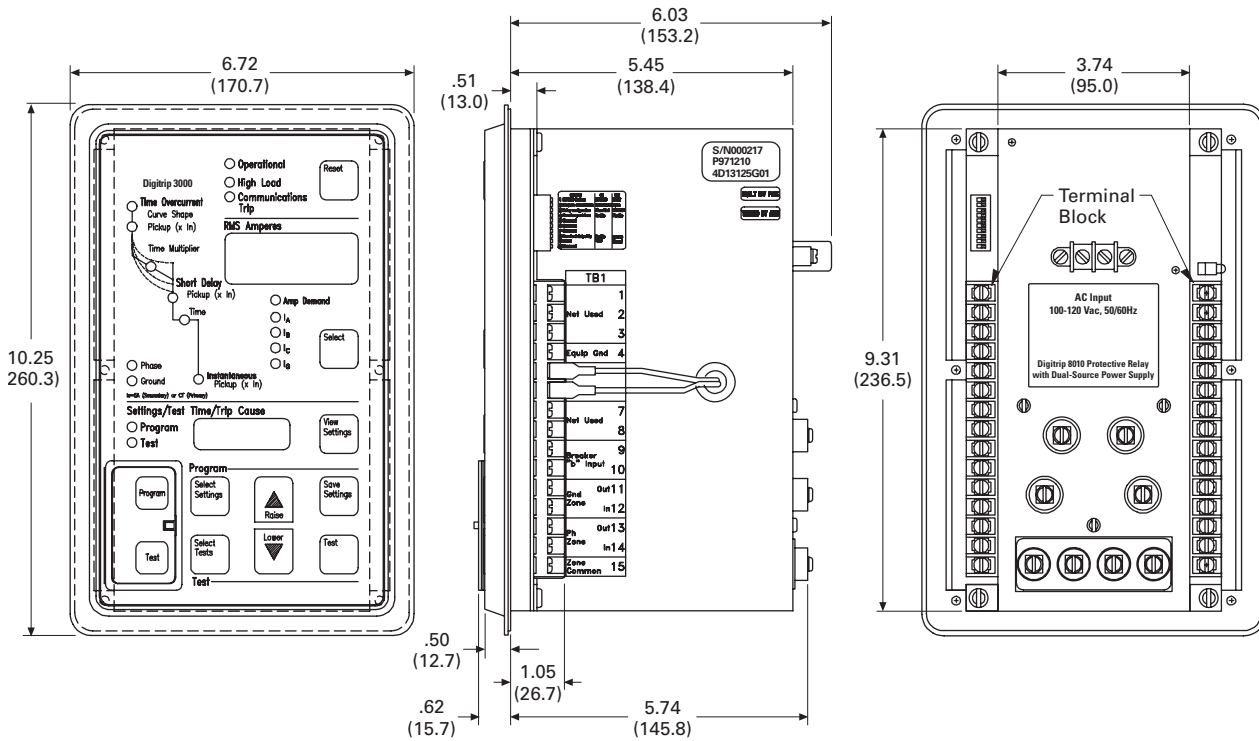

Digitrip 3000

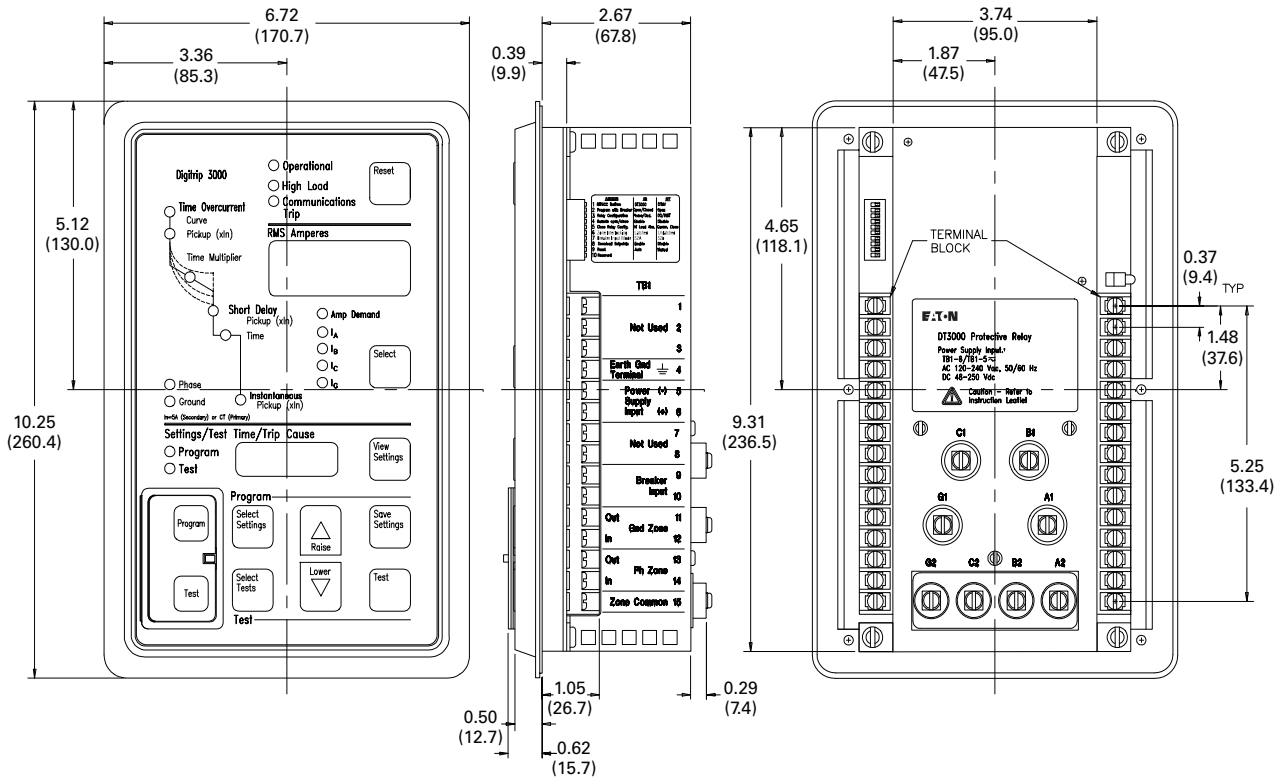

Approximate Dimensions in Inches (mm)

Rear View of Digitrip 3001 Drawout Outer Case Terminal Layout

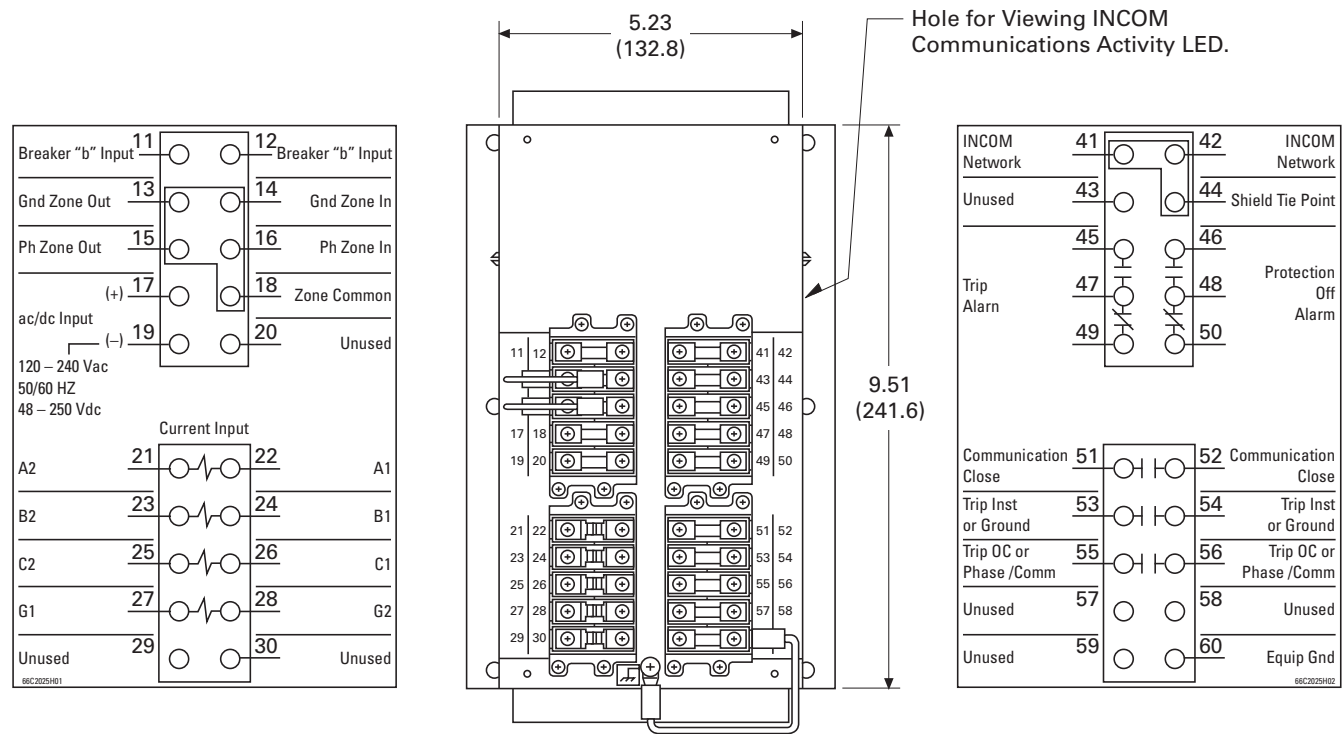

Digitrip-3000 Feeder Protection Relay (Fixed Case)

Height	Width	Depth	Shipping Weight Lbs (kg)
10.25 (260.4)	6.72 (170.7)	2.96 (75.2)	0.0 (0.0)

VR-300



Contents

<i>Description</i>	<i>Page</i>
Product Selection Guide	V3-T9-158
FP-6000 Feeder Protection	V3-T9-162
FP-5000 Feeder Protection	V3-T9-172
FP-4000 Feeder Protection	V3-T9-180
MP-3000 Motor Protection	V3-T9-188
MP-4000 Motor Protection	V3-T9-198
MD-3000 Motor/Generator Differential Relay	V3-T9-204
Digitrip 3000	V3-T9-207
VR-300 Multifunctional Voltage Relay	
Technical Data and Specifications	V3-T9-218
Dimensions	V3-T9-220
DP-300 Current Differential Protection Relay	V3-T9-221
EDR-3000 Feeder Protection	V3-T9-226
ETR-4000 Transformer Protection Relay	V3-T9-237
Ground Fault Relay	V3-T9-250
Universal RTD Module	V3-T9-254
IQ 125 Volt DC Power Supply	V3-T9-258

VR-300 Multifunctional Voltage Relay

Product Description

The VR-300 is an industrial grade protective relay that offers multiple protective features in a single package, ideal for standalone protection or for the implementation of transfer schemes.

Using a digital processor to measure true rms values enables a high degree of measuring accuracy

regardless of harmonics, transients or disturbing pulses.

The compact size and multiple functions of the VR-300 help to simplify switchgear design. The digital display offers a user-friendly interface to set up the unit as well as monitor the operation and display any alarms.

Features, Benefits and Functions

- Over-/undervoltage monitoring (59/27)
- Over-/underfrequency monitoring (81O/U)
- Voltage asymmetry monitoring (47)
- Sync-check (25) fixed to relay 3
- Zero voltage monitoring: dead bus start functionality (close CB to dead bus)
- Two configurable relays
- Discrete input for blocking of protective functions or remote acknowledgment

Standards and Certifications

- EMC-Test (CE): Tested according to applicable EN guidelines
- Listings: CE Marking; UL listing for ordinary locations, UL/cUL listed, ordinary locations, File No.: E231544
- Additional approvals: IEEE C37.90.1 and C37.90.2



Technical Data and Specifications

Measuring Voltage

- Standard (V_{rated}) delta: 66/115 Vac
- Maximum value V_{ph-ph} max., (UL/cUL): Max. 150 Vac
- Rated voltage $V_{ph-ground}$: 50 Vac/2.5 kV
- Rated surge voltage: 2.5 kV
- Measuring frequency: 40.0 to 80.0 Hz
- Accuracy: Class 1
- Linear measuring range: $1.3 \times V_{rated}$
- Input resistance: 0.21 M ohms
- Maximum power consumption per path: < 0.15W

Ambient Variables

- Wide range power supply: 90 to 250 Vac/Vdc
- Intrinsic consumption: Max. 12 VA
- Ambient temperature:
 - Storage: -22°F to 176°F (-30°C to 80°C)
 - Operational: -4°F to 158°F (-20°C to 70°C)
- Ambient humidity: 95%, noncondensing
- Maximum altitude: 6562 ft (2000m)
- Degree of pollution: 2

Discrete Inputs—Isolated

- Input range ($V_{Cont, Discrete Input}$): Rated voltage 18 to 250 Vac/Vdc
- Input resistance: Approximately 68 K ohms

Relay Outputs—Potential Free

- Contact material: AgCdO
- General purpose (GP) ($V_{Cont, Relay Output}$):
 - AC: 2.00 Aac at 250 Vac
 - DC: 2.00 Adc at 24 Vdc, 0.22 Adc at 125 Vdc, 0.10 Adc at 250 Vdc
- Pilot duty (PD) ($V_{Cont, Relay Output}$):
 - AC: B300
 - DC: 1.00 Adc at 24 Vdc, 0.22 Adc at 125 Vdc, 0.10 Adc at 250 Vdc

Housing

- Type: APRANORM DIN 43 700
- Wiring: Screw-type, terminals 2.5 mm² (0.0039 in.²)
- Recommended tightening torque: 0.5 Nm (0.369 ft/lbs). Use 140/167°F (60/75°C) Copper Wire Only. Use Class 1 Wire Only (or Equivalent)

Protection

- Protection system: IP42 from front with correct mounting
 - IP54 from front with gasket
 - (Gasket: P/N 8923-1036) IP20 from back
- Front foil: Insulating surface

Typical Nameplate

Typical VR-300 Nameplate

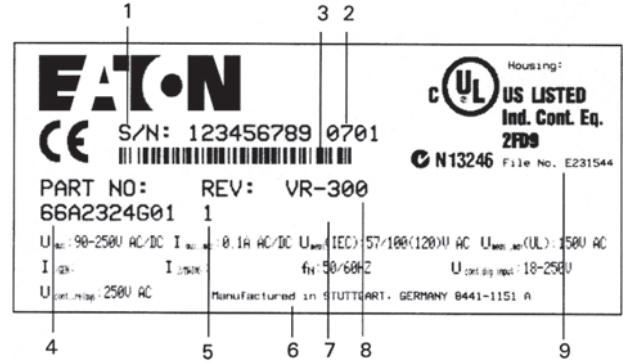

Terminal	Label	Description
1	S/N	Serial number (numerical)
2	S/N	Date of production (YYMM)
3	S/N	Serial number (Barcode)
4	P/N	Item number
5	REV	Item revision number
6	Details	Technical data
7	Type	Description (long)
8	Type	Description (short)
9	UL	UL sign

Reference Information

Reference Conditions

Measuring Value	Display Range	Accuracy
Frequency		
fL1, fL2, fL3	40.0 to 80.0 Hz	0.05 Hz
Voltage		
VL1, VL2, VL3, VL12, VL23, VL31	0 to 520, 0 to 65 kV	1% ①

The data apply to the following reference conditions:

- Input voltage = Sinusoidal rated voltage
- Frequency = Rated frequency $\pm 2\%$
- Power supply = Rated voltage $\pm 2\%$
- Power factor $\cos \phi = 1$
- Ambient temperature = 73°F (23°C) $\pm 2\text{K}$
- Warm-up period = 20 minutes

Note

- ① Accuracy depending on the configured transformer ratio.

Wiring Diagrams

Three-Line Wye

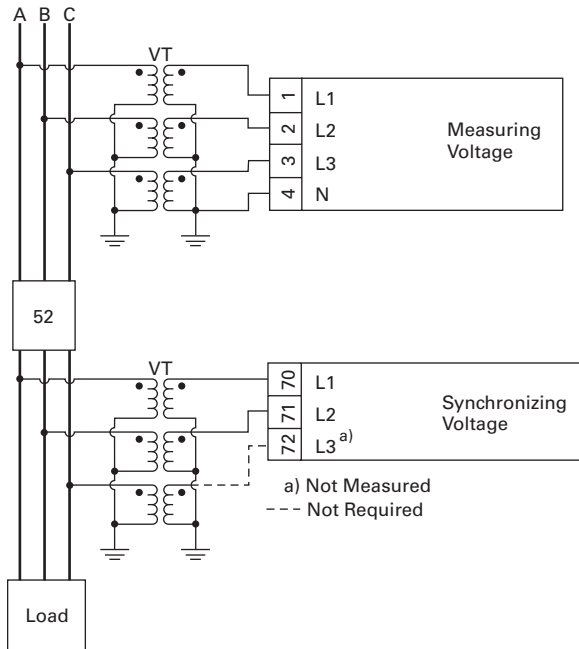

Three-Line Delta

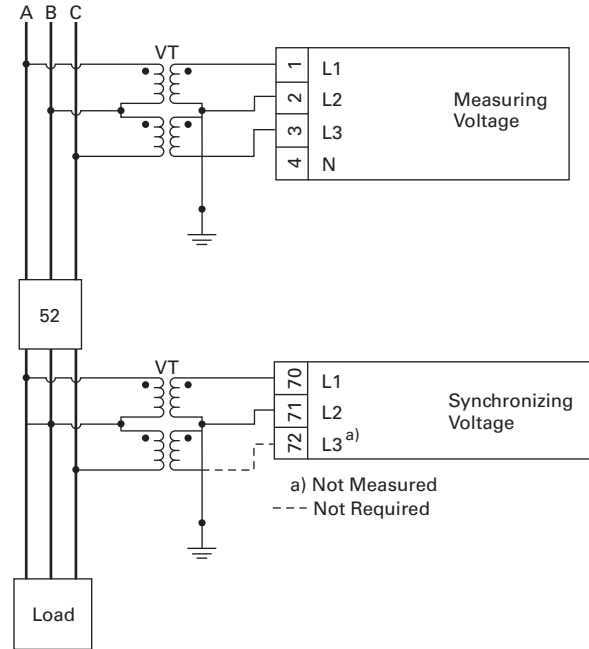

VR-300

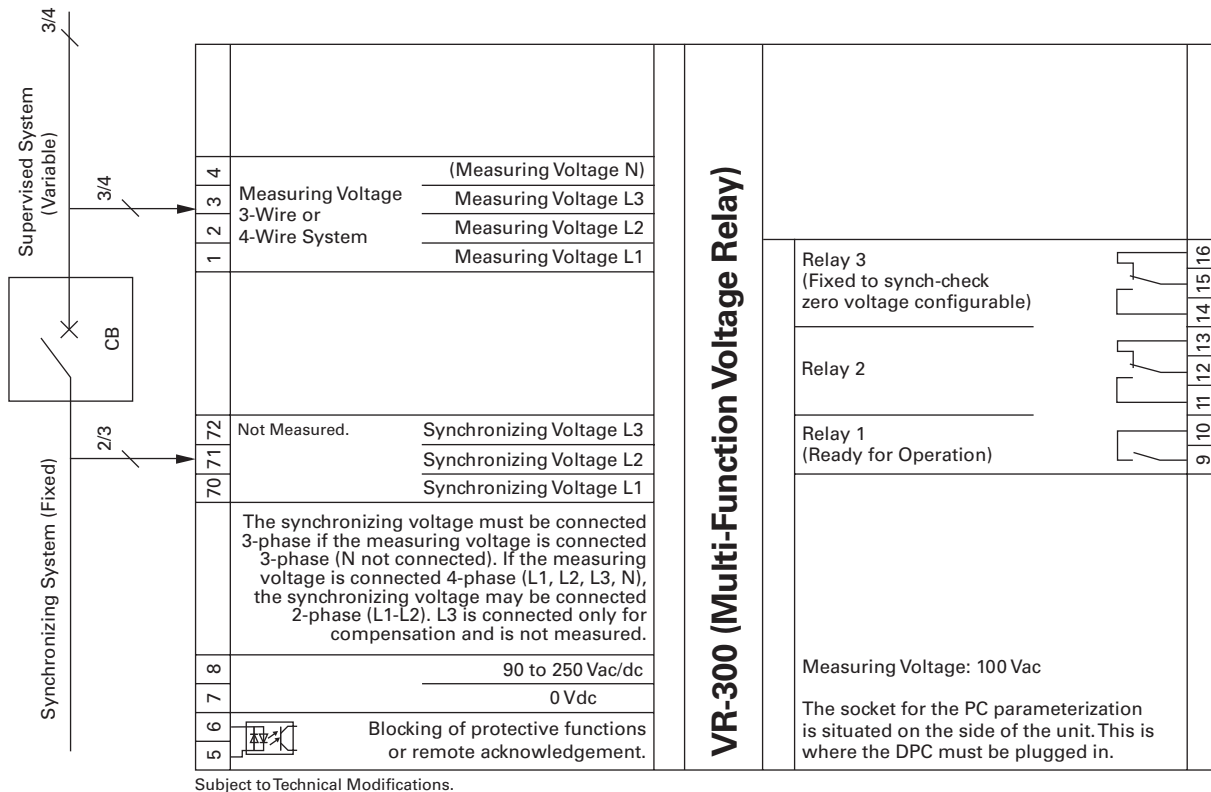

9.4

Metering Devices, Protective Relays, Software and Connectivity

Protective Relays

Dimensions

Approximate Dimensions in Inches (mm)

VR-300

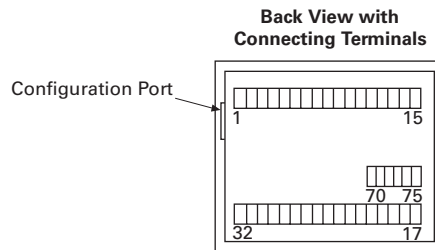
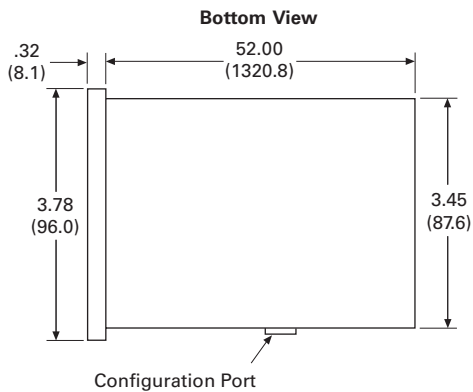
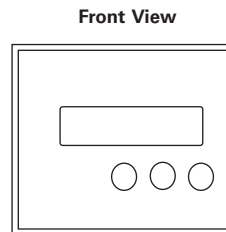
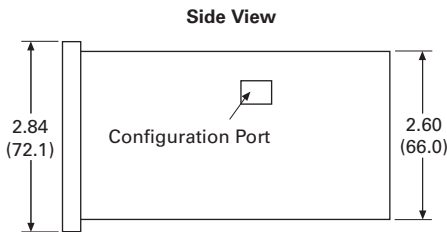

9

Front Panel Cutout

Width	Height
3.62 [+0.03] (92.0 [+0.8])	2.68 [+0.03] (68.0 [+0.7])

VR-300 Dimensions

Width	Height	Depth	Shipping Weight Lbs (kg)
3.78 (96.0)	2.84 (72.1)	5.20 (132.1)	2.14 (0.97)

VR-300 Panel Cutout

Measure	Description	Dimensions in Inches (mm)	Tolerance in Inches (mm)
Height			
H	Total	2.83 (71.9)	—
h	Panel cutout	2.68 (68.1)	0.03 (+0.7)
h'	Housing dimension	2.60 (66.0)	—
Width			
B	Total	3.78 (96.0)	—
b	Panel cutout	3.62 (91.9)	0.03 (+0.8)
b'	Housing dimension	3.54 (89.9)	—
Depth (Including Terminals)			
	Total	6.30 (160.0)	—

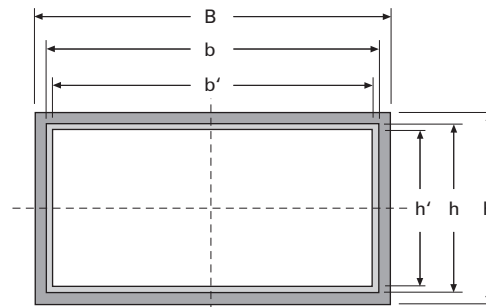

The maximum permissible corner radius for cutout is 0.08 inches (2.0 mm).

DP-300



Contents

<i>Description</i>	<i>Page</i>
Product Selection Guide	V3-T9-158
FP-6000 Feeder Protection	V3-T9-162
FP-5000 Feeder Protection	V3-T9-172
FP-4000 Feeder Protection	V3-T9-180
MP-3000 Motor Protection	V3-T9-188
MP-4000 Motor Protection	V3-T9-198
MD-3000 Motor/Generator Differential Relay	V3-T9-204
Digitrip 3000	V3-T9-207
VR-300 Multifunctional Voltage Relay	V3-T9-217
DP-300 Current Differential Protection Relay	
Standards and Certifications	V3-T9-222
Technical Data and Specifications	V3-T9-222
Dimensions	V3-T9-224
EDR-3000 Feeder Protection	V3-T9-226
ETR-4000 Transformer Protection Relay	V3-T9-237
Ground Fault Relay	V3-T9-250
Universal RTD Module	V3-T9-254
IQ 125 Volt DC Power Supply	V3-T9-258

DP-300 Current Differential Protection Relay

Product Description

The current flowing in the individual conductors is measured by means of current transformers installed on both sides of the protection zone. These transformers form the limits of the protection zone. By means of freely configurable relays, the unit will indicate if any of the adjusted fault current limits have been exceeded. The unit counts with a slope characteristic to prevent operation due to CT ratio mismatches, CT ratio errors, CT saturation and errors because of tap changes.

For transformer applications, the unit has 2nd and 5th harmonic restraints to prevent misoperation in case of inrush currents caused for energization or over excitation of the transformer.

When used in transformer applications, the DP-300 allows you to change the phase shift of the transformer, without having to worry about changing the connection of the external CTs, via selecting the vector group in the display. The different nominal currents of the high and low voltage side of the transformer, as well as the transformer ratio, may be configured. Every measuring point may be set separately. These features permit the DP-300 to be universal in its applications.

The DP-300 permits design simplification of the switchgear cabinet, facilitates the commissioning, ensures the operation of the system, is user friendly and increases the availability of the system.

Application Description

The DP-300 offers a three-phase current differential protection for generators, motors and two winding transformers, see **Page V3-T9-223**.

Features, Benefits and Functions

- True rms 6 x current measurement, three-phase system on both sides of the protected zone
- Secondary current transformer output available as: /1A or /5A
- Configurable trip set points for:
 - Differential current (I_d)
 - Restrain current (I_s)
- Configurable delays
- Four alarm relays
- Three discrete inputs (for blocking, acknowledgment and configuration)
- Two-line LC display
- Configurable transformer ratio
- Configurable vector group
- Transformer inrush detection/suppression
- Individual configuration of the nominal current for the high- and low-voltage side of the transformer
- Configurable transformer ratio separated for currents of high- and low-voltage side of the transformer

Standards and Certifications

- Listings: CE marking; UL listing for ordinary locations, UL/cUL listed, ordinary locations, File No.: E231544
- Additional Approvals: IEEE C37.90.1 and C37.90.2

- EMC-Test (CE): Tested according to applicable EN guidelines



Technical Data and Specifications

Measurements, Currents—Isolated

- Measured currents (Nominal value IN): /5A
- Measuring frequency: 40.0 to 70.0 Hz
- Accuracy: Class 1
- Linear measuring range: 5.0 x IN
- Maximum power consumption per path: < 0.15 VA
- Rated short time current (1s): 30.0 x IN

Ambient Conditions

- Voltage supply: 90 to 250 Vac/Vdc
- Intrinsic consumption: Max. 10 VA
- Ambient temperature storage: -22°F to 176°F (-30°C to 80°C)
- Operational: -4°F to 158°F (20°C to 70°C).
- Ambient humidity: 95%, noncondensing
- Maximum altitude: 6562 ft (2000m)
- Degree of pollution: 2

Digital Inputs—Isolated

- Input range (V_{Cont, Digital Input}):
 - Nominal voltage
 - 18 to 250 Vac/Vdc
- Input resistance: Approximately 68 K ohms

Relay Outputs—Isolated

- Contact material: AgCdO
- Resistive load (GP) (V_{Cont, Relay Output}):
 - AC: 2.00 Aac @ 250 Vac
 - DC: 2.00 Adc @ 24 Vdc, 0.36 Adc @ 125 Vdc, 0.18 Adc @ 250 Vdc
- Inductive load (PD) (V_{Cont, Relay Output}):
 - AC: B300
 - DC: 1.00 Adc @ 24 Vdc, 0.22 Adc @ 125 Vdc, 0.10 Adc @ 250 Vdc

Protective Functions

- Operating Time: Minimum 100m
- Differential current: Minimum 10%

Housing

- Type: APRANORM DIN 43 700
- Terminals: Screw-type, terminals depending on connector, 0.00388 in.² (2.5 mm²) or 0.00620 in.² (4.0 mm²)
- Recommended tightening torque:
 - 4.43 in./lbs / [0.00620 in.²] 5.3 in./lbs)
 - [2.5 mm²] 0.5 Nm / [4.0 mm²] 0.6 Nm ([0.00388 in.²])
- Use 140°F/167°F (60°C/75°C) copper wire only
- Use Class 1 wire only (or equivalent)

Housing Protection

- Protection system:
 - IP42 from front with correct mounting
 - IP54 from front with gasket
 - Gasket: P/N 8923-1038)
 - IP20 from back
- Front foil: Insulating surface

Transformer Vector Groups

Transformer Vector Groups

Vector Group	Description
Yd5	HV: λ-Circuit Arrangement, LV: Δ-Circuit Arrangement, 5 x 30° = 150°
Yy0	HV: λ-Circuit Arrangement, LV: λ-Circuit Arrangement, 0°
Dy5	HV: Δ-Circuit Arrangement, LV: λ-Circuit Arrangement, 5 x 30° = 150°
Dd0	HV: Δ-Circuit Arrangement, LV: Δ-Circuit Arrangement, 0°
Yz5	HV: λ-Circuit Arrangement, LV: Z-Circuit Arrangement, 5 x 30° = 150°
Dz0	HV: Δ-Circuit Arrangement, LV: Z-Circuit Arrangement, 0°
Yd11	HV: λ-Circuit Arrangement, LV: Δ-Circuit Arrangement, 11 x 30° = 330°
Yy6	HV: λ-Circuit Arrangement, LV: λ-Circuit Arrangement, 6 x 30° = 180°
Dy11	HV: Δ-Circuit Arrangement, LV: λ-Circuit Arrangement, 11 x 30° = 330°
Dd6	HV: Δ-Circuit Arrangement, LV: Δ-Circuit Arrangement, 6 x 30° = 180°
Yz11	HV: λ-Circuit Arrangement, LV: Z-Circuit Arrangement, 11 x 30° = 330°
Dz6	HV: Δ-Circuit Arrangement, LV: Z-Circuit Arrangement, 6 x 30° = 180°

Typical Nameplate

Typical DP-300 Nameplate

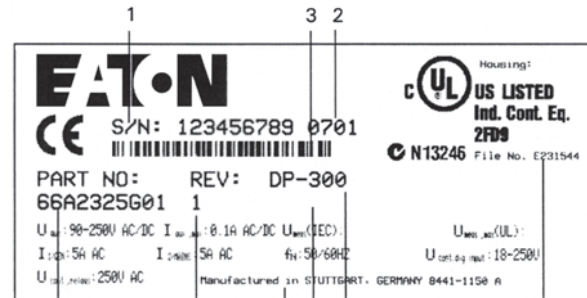

1	S/N	Serial Number (Numerical)
2	S/N	Date of Production (YYMM)
3	S/N	Serial Number (Bar Code)
4	P/N	Item Number
5	REV	Item Revision Number
6	Details	Technical Data
7	Type	Description (Long)
8	Type	Description (Short)
9	UL	UL Sign

Wiring Diagrams

Protected Area Principle—Fault “A” Outside = No Alarm, Fault “B” Inside = Alarm

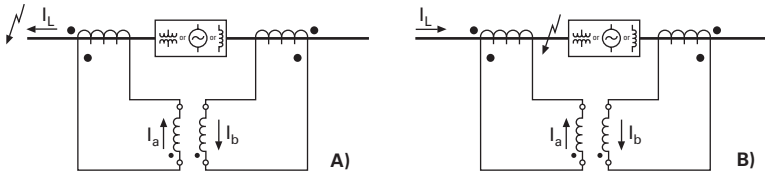

Schematic Circuit Diagrams (Single-Phase Version):
 A) Fault Outside the Protection Area
 B) Fault Inside the Protection Area

DP-300

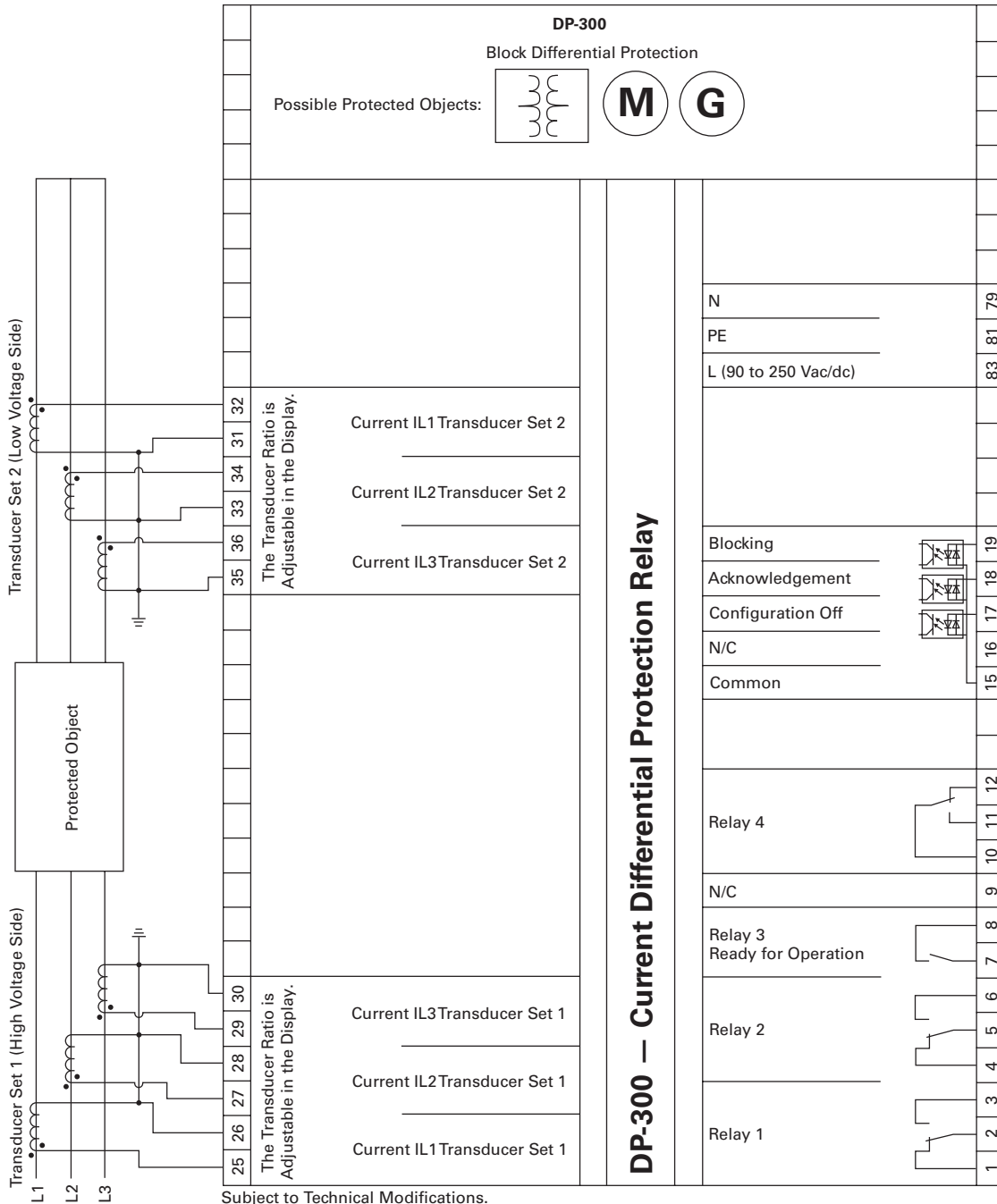

Tripping Characteristics

DP-300

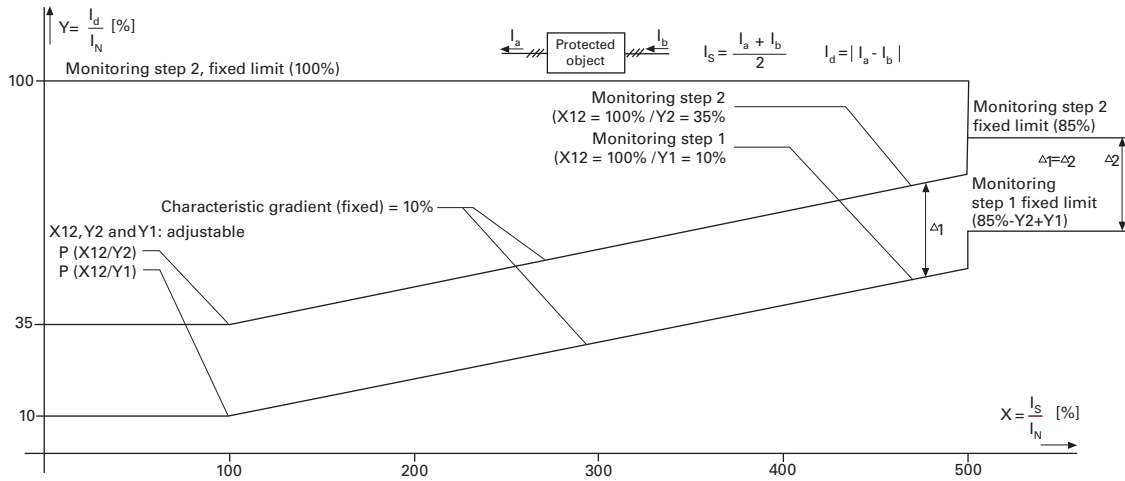

Dimensions

Approximate Dimensions in Inches (mm)

DP-300

Width	Height	Depth	Shipping Weight Lbs (kg)
5.67 (144.0)	3.78 (96.0)	5.20 (132.1)	2.2 (0.99)

DP-300

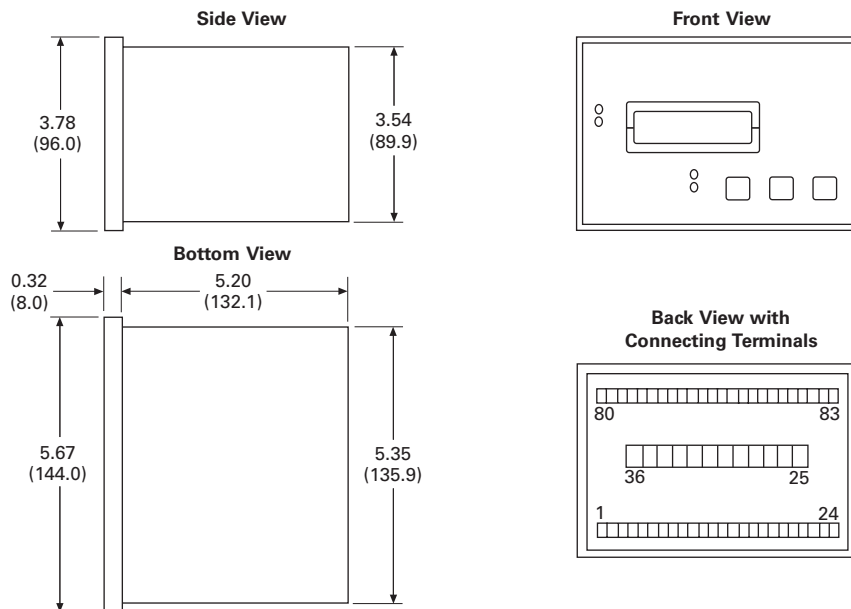

Approximate Dimensions in Inches (mm)

Front panel cutout

Width	Height
5.43 [+0.039] (138.0 [+1.0])	3.63 [-0.031] (92.0 [+0.8])

DP-300 Panel Cutout

Measure	Description	Dimensions	Tolerance
Height			
H	Total	3.78 (96.0)	—
h	Panel cutout	3.62 (91.9)	0.03 (+0.8)
h'	Housing dimension	3.54 (89.9)	—
Width			
B	Total	5.67 (144.0)	—
b	Panel cutout	5.43 (137.9)	0.04 (+1.0)
b'	Housing dimension	5.35 (135.9)	—
Depth (Including Terminals)			
	Total	6.30 (160.0)	—

The maximum permissible corner radius for cutout is 0.08 inches (2.0 mm).

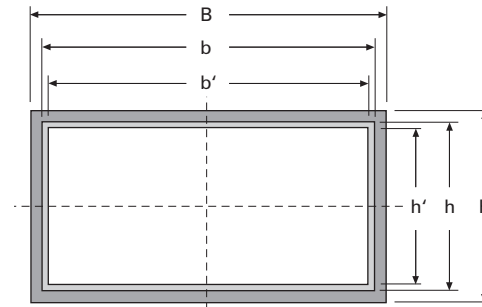

EDR-3000



Contents

<i>Description</i>	<i>Page</i>
Product Selection Guide	V3-T9-158
FP-6000 Feeder Protection	V3-T9-162
FP-5000 Feeder Protection	V3-T9-172
FP-4000 Feeder Protection	V3-T9-180
MP-3000 Motor Protection	V3-T9-188
MP-4000 Motor Protection	V3-T9-198
MD-3000 Motor/Generator Differential Relay	V3-T9-204
Digitrip 3000	V3-T9-207
VR-300 Multifunctional Voltage Relay	V3-T9-217
DP-300 Current Differential Protection Relay	V3-T9-221
EDR-3000 Feeder Protection	
Features, Benefits and Functions	V3-T9-228
Standards and Certifications	V3-T9-228
Catalog Number Selection	V3-T9-229
Technical Data and Specifications	V3-T9-230
Dimensions	V3-T9-235
ETR-4000 Transformer Protection Relay	V3-T9-237
Ground Fault Relay	V3-T9-250
Universal RTD Module	V3-T9-254
IQ 125 Volt DC Power Supply	V3-T9-258

EDR-3000 Feeder Protection

Product Description

The EDR-3000 Protective Relay is a multifunction, microprocessor-based overcurrent relay designed for both ANSI and IEC applications. It is a panel-mounted, self-contained unit that operates from either AC or DC control power. The EDR-3000 design provides true rms and fundamental sensing of each phase and ground current. Only one unit is required for each three-phase circuit.

Current monitoring and operator selectable protective functions are integral to each relay. The EDR-3000 relay operates from the 5A or 1A secondary output of standard current transformers. Current transformer ratio information is quickly programmed into the unit via settings. This enables the relay to display metered current in primary amperes, secondary amperes or per unit values. The EDR-3000 features a user-friendly operations panel to monitor and program the relay. Operating parameters and troubleshooting information are displayed in the 128 x 64 LCD. In addition, all data and information can be

communicated to a host computer equipped with PowerPort-E™. A "Communication Trip" and "Communication Close" control command can also be initiated by a host computer with an authorized access code for remote breaker operation.

Application Description

The EDR-3000 microprocessor-based relay provides reliable three-phase and ground overcurrent protection for all voltage levels. It can be used for any application where instantaneous and/or time overcurrent protection is required. It is most commonly used as primary feeder circuit protection, shown below.

Primary Feeder Circuit Protection

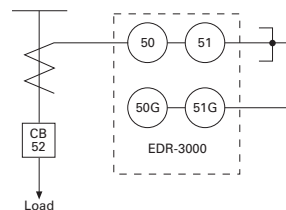

The EDR-3000 may be applied as the transformer primary protection or as backup to the differential protection, see below.

Transformer Overcurrent Protection

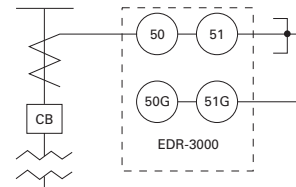

The EDR-3000 may be connected to the secondary side of a delta-wye grounded transformer with the ground element connected to a separate CT in the neutral connection of the transformer. With this connection, a lower CT ratio and a pickup setting can be used to provide more sensitive ground fault protection especially for resistance grounded systems, shown below.

Transformer Secondary Protection with Neutral CT Connection

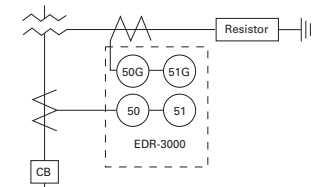

The EDR-3000 relay has special provisions for connection in a Zone Interlocking scheme that can be used for bus protection or to improve protection coordination in a tight or close system. Zone Interlocking is described in following sections. In addition the EDR-3000 has multiple setting groups that can be used to reduce arc flash hazard with instantaneous elements.

Residual Ground Connection

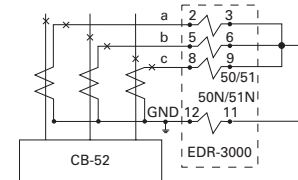

Overcurrent Protection

The EDR-3000 provides complete three-phase and ground protection with separate elements and settings. The relay can be used with CTs from 1 to 50,000A of primary current and 1 or 5A of secondary current. The CT ratio can be set independently for phase and ground, allowing the ground element to be connected in either the residual or the separate ground CT configuration, shown on below.

Separate Zero Sequence Ground CT Connection

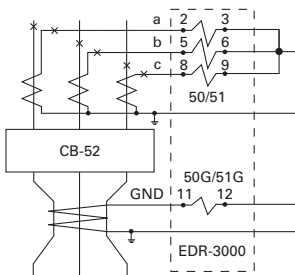

Zone Selective Interlocking (Phase and Ground)

Note: Refer to the Ordering Information and (Catalog Ordering Information) for optional features, see **Page V3-T9-229**.

Zone Selective interlocking is a protection function to minimize equipment damage resulting from a phase or a ground fault in an area where long time and/or short time delay is in use.

When the "Ground Zone Interlocking" feature is utilized, an immediate trip is initiated when the fault is in the breaker's zone of protection, regardless of its preset time delay. When the "Phase Zone Interlocking" feature is utilized, the time overcurrent elements work as follows. The instantaneous phase element will initiate an immediate trip when the fault is in the breaker's zone of protection, regardless of its preset time delay. For the time overcurrent phase element, the current sensed by the EDR-3000 must exceed 1.5 times the pickup setting for the zone selective interlocking to initiate an immediate trip signal when the fault is in the breaker's zone of protection.

Upstream EDR-3000 protected breakers are restrained from tripping immediately by an interlocking signal from the downstream EDR-3000 relay. This interlocking signal requires only a pair of wires from the downstream breaker to the upstream breaker. It provides standard

coordinated tripping when the fault is located outside the zone of protection.

In the sample zone interlocking system shown below, circuit breakers A, B and C are equipped with EDR-3000 overcurrent relays.

Fault Location Zone 3

Note: For the time overcurrent phase element, the current sensed by the EDR-3000 must exceed 1.5 times the pickup setting for the zone selective interlocking to initiate an immediate trip signal when the fault is in the breaker's zone of protection.

If a fault occurs at a point in Zone 3, the EDR-3000 of downstream breaker C senses the fault and sends a restraining signal to the upstream EDR-3000 of feeder breaker B. Having received this signal, the EDR-3000 of feeder breaker B withholds its trip command. As a result, only downstream breaker C is tripped.

Fault Location Zone 2

Note: For the time overcurrent phase element, the current sensed by the EDR-3000 must exceed 1.5 times the pickup setting for the zone selective interlocking to initiate an immediate trip signal when the fault is in the breaker's zone of protection.

If a fault occurs at a point in Zone 2, the EDR-3000 of feeder breaker B senses the fault and sends a restraining signal to the upstream EDR-3000 of main breaker A. The EDR-3000 of the downstream breaker C does not see this fault since it is situated on the downstream side of the fault. As a result, the EDR-3000 of downstream breaker C does not send a restraining signal to the EDR-3000 of feeder breaker B. Since it did not receive a restraining signal from the EDR-3000 of downstream breaker C, the EDR-3000 of feeder breaker B identifies that the fault is in Zone 2 and immediately trips feeder breaker B, regardless of its time setting.

Fault Location Zone 1

Note: For the time overcurrent phase element, the current sensed by the EDR-3000 must exceed 1.5 times the pickup setting for the zone selective interlocking to initiate an immediate trip signal when the fault is in the breaker's zone of protection.

If a fault occurs in Zone 1, no restraining signal is received by the Digitrip of main breaker A. As a result, main breaker A is immediately tripped by its EDR-3000 overcurrent relay, regardless of its time setting.

Sample Zone Selective Interlocking System

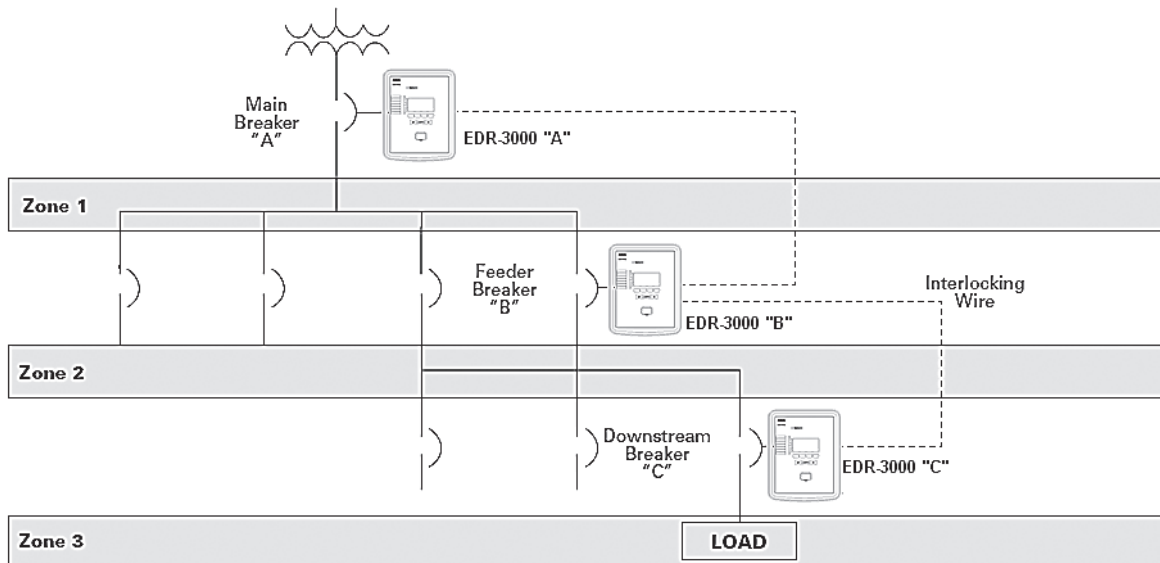

Features, Benefits and Functions

Applications

- Provides reliable three-phase and ground overcurrent protection for all voltage levels
- Primary feeder circuit protection
- Primary transformer protection
- Backup to differential protection
- May be used where instantaneous and/or time overcurrent protection is required
- Ground element capable of residual, zero sequence or external source connections

Protection Functions

- Breaker failure (50BF)
- Phase overcurrent protection per time-current curve (51-1, 51-2, 51-3)
- Calculated ground fault protection per time-current curve (51R-1, 51R-2)
- Independent measured ground or neutral fault protection per time-current curve (51X-1, 51X-2)
- Phase instantaneous overcurrent (50-1, 50-2, 50-3)

- Calculated ground or neutral instantaneous overcurrent (50R-1, 50R-2)
- Independent measured ground or neutral instantaneous overcurrent (50X-1, 50X-2)
- Curve shapes: ANSI, IEC, or thermal curves (11 thermal curves)
- Instantaneous or time delay reset
- True rms or fundamental sensing of each phase and ground current
- Zone selective interlocking (phase and ground) or reverse blocking for bus protection

Note: Refer to the Ordering Information and **Page V3-T9-229** (Catalog Ordering Information) for optional features.

Metered Values

- rms and fundamental phase currents
- rms and fundamental ground currents
- Maximum, minimum and average rms and fundamental phase currents
- Maximum, minimum and average rms and fundamental ground currents

Monitored and Data Recording Values

- Trip circuit monitoring

Note: Refer to the Ordering Information and **Page V3-T9-229** (Catalog Ordering Information) for optional features.

- Breaker wear (accumulated interrupted current)
- Fault data logs (up to 20 events)
- Sequence of event recorders (up to 300 events)
- Waveform capture (3600 cycles total)
- CT supervision

Control Functions

- Remote open/close
- Programmable I/O
- Programmable LEDs
- Multiple setting groups (up to four)

Communication

- Local HMI
- Front RS-232 port
- Rear RS-485 port
- IRIG-B11
- Protocols
 - Modbus RTU

Standards and Certifications

- Generic standard:
 - EN 61000-6-2
 - EN 61000-6-3
- Product standard:
 - EC 60255-6
 - EN 50178
- UL 508 (Industrial Control Equipment)
- CSA C22.2 No. 14-95 (Industrial Control Equipment)
- ANSI C37.90
- UL, CSA, CE



Catalog Number Selection

The catalog number identification chart defines the electrical characteristics and operation features included in the EDR-3000. For example, if the catalog number were EDR3000-A0BA1, the device would have the following:

EDR-3000

(A)—Four digital inputs, four output relays

(0)—Phase current 5A/1A, Ground Current 5A/1A, Power supply: 19–300 Vdc, 40–250 Vac

(B)—Modbus-RTU (RS-485)

(A)—Without conformal coating

(1)—Projection panel mount

Relay Removable Terminals

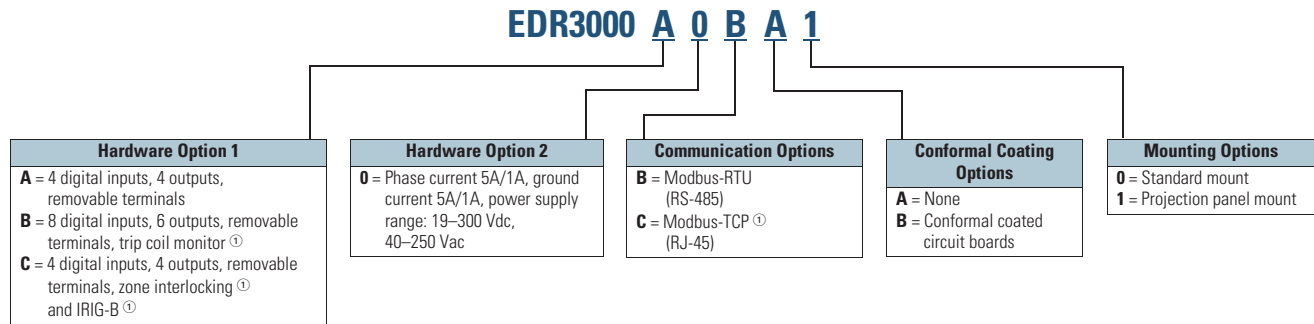

Relay Fixed Terminals ②

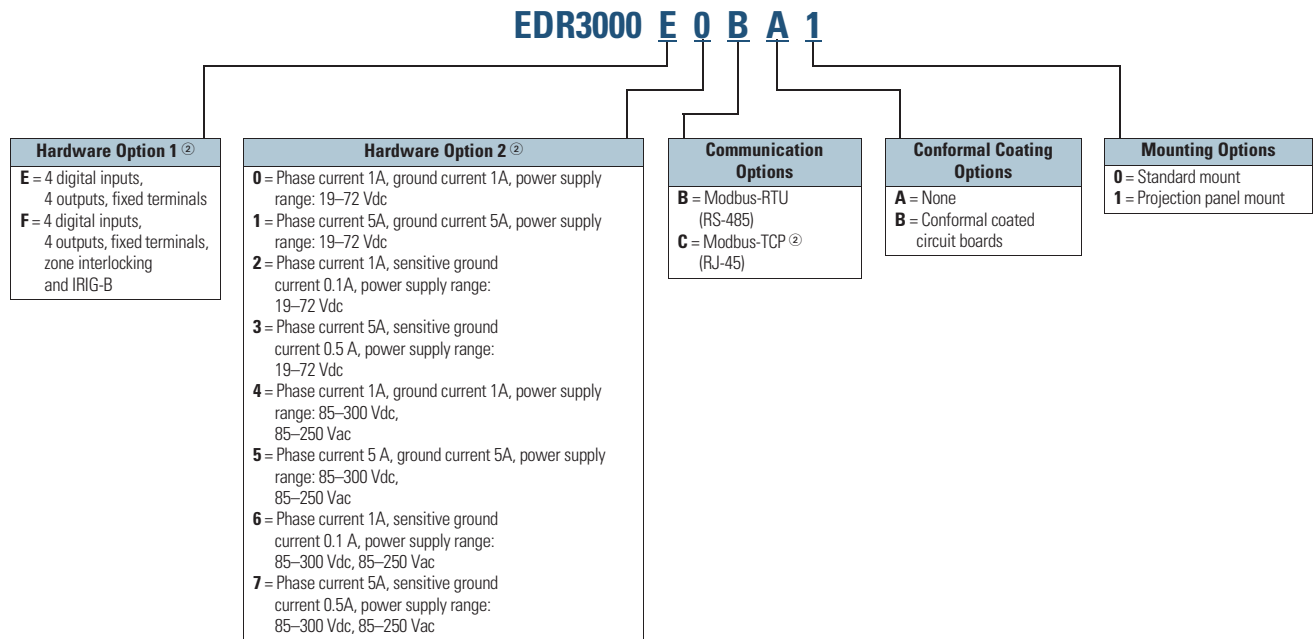

Notes

- ① Consult factory for the availability of eight digital inputs, six outputs, trip coil monitor, zone interlocking, IRIG-B and Modbus-TCP.
- ② Consult factory for the availability of fixed terminals.

Technical Data and Specifications

Climatic Environmental Conditions

- Storage temperature: –13°F to 158°F (–25°C up to +70°C)
- Operating temperature: –4°F to 140°F (–20°C up to +60°C)
- Permissible humidity at ann. average: <75% rel. (on 56d up to 95% rel.)
- Permissible Installation altitude:
 - <2000m (6561.67 ft) above sea level
 - If 4000m (13,123.35 ft) altitude apply, a changed classification of the operating and test voltages may be necessary

Degree of Protection EN 60529

- HMI front panel with seal: IP54
- Rear side terminals: IP30

Routine Test

- Insulation test according to IEC 60255-5: All tests to be carried out against ground and other input and output circuits
- Aux. voltage supply, digital inputs, current measuring inputs, signal relay outputs: 2.5 kV (eff)/50 Hz
- Voltage measuring inputs: 3.0 kV (eff)/50 Hz
- All wire-bound communication interfaces: 1.5 kV DC

Housing

- Material, housing: aluminum extruded section
- Material, front panel: aluminum/foil front
- Mounting position: horizontal ($\pm 45^\circ$ around the X-axis must be permitted)

Plug-in Connector with Integrated Short-Circuiter (Conventional Current Inputs)

- Nominal current: 1A and 5A
- Continuous loading capacity: $4 \times I_n$ /continuously
- Overcurrent withstand: $30 \times I_n/10s$
- $100 \times I_n/1s$
- $250 \times I_n/10 ms$ (1 half-wave)
- Screws: M4, captive type according to VDEW
- Connection cross-sections:
 - $2 \times 2.5 mm^2$ (2 x AWG 14) with wire end ferrule
 - $1 \times$ or $2 \times 4.0 mm^2$ (2 x AWG 12) with ring cable sleeve or cable sleeve
 - $1 \times$ or $2 \times 6 mm^2$ (2 x AWG 10) with ring cable sleeve or cable sleeve

Voltage Supply

- Aux. voltage: 19–300 Vdc/40–250 Vac
- Buffer time in case of supply failure: $\geq 50 ms$ at minimal aux. voltage communication is permitted to be interrupted
- Max. permissible making current:
 - 18A peak value for <0.25 ms
 - 12A peak value for <1 ms
- The voltage supply must be protected by a fuse of:
 - 2.5A time-lag miniature fuse $5 \times 20 mm$ (approx. $1/5 in. \times 0.8 in.$) according to IEC 60127
 - 3.5A time-lag miniature fuse $6.3 \times 32 mm$ (approx. $1/4 in. \times 1 1/4 in.$) according to UL 248-14

Power Consumption

- Power supply range: Power consumption in idle mode
- Max. power consumption
- 19–300 Vdc: 6W 8.5W
- 40–250 Vac
- For frequencies of 40–70 Hz: 6W 8.5W

Real-Time Clock

- Running reserve of the real-time clock: 1 year min

Display

- Display type: LCD with LED background illumination
- Resolution graphics display: 128×64 pixel
- LED-type: two colored, red/green
- Number of LEDs, housing B1: 8

Digital Inputs

- Max. input voltage: 300 Vdc/270 Vac
- Input current: <4 mA
- Reaction time: <20 ms
- Fallback time: <30 ms (safe state of the digital inputs)
- Four switching thresholds: $U_n = 24 Vdc, 48 Vdc, 60 Vdc, 110 Vac/dc, 230 Vac/Vdc$ $U_n = 24 Vdc$
 - Switching threshold 1 ON
 - Switching threshold 1 OFF
 - Min. 19.2 Vdc
 - Max. 9.6 Vdc
 - $U_n = 48 V/60 Vdc$
 - Switching threshold 2 ON
 - Switching threshold 2 OFF
 - Min. 42.6 Vdc
 - Max. 21.3 Vdc
 - $U_n = 110/120 Vac/dc$
 - Switching threshold 3 ON
 - Switching threshold 3 OFF
 - Min. 88.0 Vdc/88.0 Vac
 - Max. 44.0 Vdc/44.0 Vac
 - $U_n = 230/240 Vac/Vdc$
 - Switching threshold 4 ON
 - Switching threshold 4 OFF
 - Min. 184 Vdc/184 Vac
 - Max. 92 Vdc/92 Vac
- Terminals: screw-type terminal

Current and Ground Current Measurement.

- Nominal currents: 1A/5A
- Max. measuring range:
 - up to $40 \times I_n$ (phase currents)
 - up to $25 \times I_n$ (ground current standard)
 - up to $2.5 \times I_n$ (ground current sensitive)
- Continuous loading capacity: $4 \times I_n$ /continuously
- Overcurrent proof:
 - $30 \times I_n/10s$
 - $100 \times I_n/1s$
 - $250 \times I_n/10 ms$ (1 half-wave)
- Power consumption: Phase current inputs
 - at $I_n = 1A S = 0.15 mVA$
 - at $I_n = 5A S = 0.15 mVA$
- Ground current input
 - at $I_n = 1A S = 0.35 mVA$
 - at $I_n = 5A S = 0.35 mVA$
- Frequency range: 50 Hz/60 Hz $\pm 10\%$
- Terminals: Screw-type terminals with integrated short-circuiters (contacts)

Binary Output Relays

- Continuous current: 5A AC/DC
- Switch-on current: 25A AC/DC for 4s
- Max. breaking current: 5A AC up to 125 Vac
- 5A DC up to 50V (resistive)
- 0.2A DC at 300V
- Max. switching voltage: 250 Vac/300 Vdc
- Switching capacity: 2000 VA
- Contact type: 1 changeover contact
- Terminals: Screw-type terminals

Front Interface RS-232

- Baud rates: 115,200 baud
- Handshake: RTS and CT
- Connection: 9-pole D-Sub plug

RS-485

- Master/Slave: Slave
- Connection: 6 screw-clamping terminals RM 3.5 mm (138 MIL) (terminating resistors internal)

Tolerances of the Real-Time Clock

- Resolution: 1 ms
- Tolerance: <1 minute/month (+20°C)

Measuring Accuracy

- Max. measuring range: up to $40 \times I_n$ (phase currents) up to $25 \times I_n$ (ground current standard)
- Frequency range: 50 Hz/60 Hz $\pm 10\%$
- Accuracy: Class 0.5
- Amplitude error if $I < I_n$: $\pm 0.5\%$ of the rated value
- Amplitude error if $I > I_n$: $\pm 0.5\%$ of the measured value
- Amplitude error if $I > 2 I_n$: $\pm 1.0\%$ of the measured value
- Resolution: 0.01A
- Harmonics up to 20% 3rd harmonic $\pm 2\%$ up to 20% 5th harmonic $\pm 2\%$
- Frequency influence < $\pm 2\%/Hz$ in the range of $\pm 5 Hz$ of the parameterized nominal frequency
- Temperature influence < $\pm 1\%$ within the range of 0°C up to +60°C

Protection Stages Tolerances**Overcurrent Protection Stages 50P(X), 51P(X)**

Description		Range	Step	Tolerance
Pickup	If the pick-up value is exceeded, the module/stage is started.	0.01–40.00 x I_n	0.01 x I_n	±1.5% of the setting value resp. 1% I_n
Resetting ratio		97% or 0.5% x I_n	—	—
t	Tripping delay	0.00–300.00 x s	0.01 x s	DEFT ±% resp. ±10 ms
Operating time	Starting from I higher than 1.1 x I>	—	—	<+35 ms
Disengaging time		—	—	<+45 ms
t-multiplier	Time multiplier/tripping characteristic factor	0.05–2.00	0.01	±5%
	IEC NINV	0.05–2.00	0.01	±5%
	IEC VINV	0.05–2.00	0.01	±5%
	IEC EINV	0.05–2.00	0.01	±5%
	IEC LINV	0.05–2.00	0.01	±5%
	ANSI MINV	0.05–2.00	0.01	±5%
	ANSI VINV	0.05–2.00	0.01	±5%
	ANSI EINV	0.05–2.00	0.01	±5%
	Flat	0.05–2.00	0.01	±5%
	It	0.05–2.00	0.01	±5%
	I ² t	0.05–2.00	0.01	±5%
	I ⁴ t	0.05–2.00	0.01	±5%
Reset mode	Only available if IEC characteristics	0.00–60.00	0.01 x s	±1% resp. ±10 ms
	IEC NINV	0.00–60.00	0.01 x s	±1% resp. ±10 ms
	IEC VINV	0.00–60.00	0.01 x s	±1% resp. ±10 ms
	IEC EINV	0.00–60.00	0.01 x s	±1% resp. ±10 ms
	IEC LINV	0.00–60.00	0.01 x s	±1% resp. ±10 ms
	Reset curves if ANSI characteristics	—	—	5%
	ANSI MINV	—	—	5%
	ANSI VINV	—	—	5%
	ANSI EINV	—	—	5%
	Flat	—	—	5%
	It	—	—	5%
	ANSI MINV	—	—	5%
	I ² t	—	—	5%
	I ⁴ t	—	—	5%

Note

The tripping delay relates to the time between pickup and trip. The tolerance of the operating time relates to the time between the measured value has exceeded the threshold until the protection stage is alarmed.

Ground Current Stages 50G(X), 50N(X), 51G(X), 51N(X)

Description		Range	Step	Tolerance
Pickup	If the pick-up value is exceeded, the module/stage is started.	$0.01-40.00 \times I_n$	$0.01 \times I_n$	$\pm 1.5\%$ of the setting value resp. $1\% I_n$
Resetting ratio		97% or $0.5\% \times I_n$	—	—
t	Tripping delay	$0.00-300.00 \times s$	$0.01 \times s$	DEFT $\pm\%$ resp. ± 10 ms
Operating time	Starting from IG higher than $1.1 \times I >$	—	—	$<+35$ ms
Disengaging time		—	—	$<+45$ ms
t-multiplier	Tripping characteristic factor	$0.05-2.00$	0.0	$\pm 5\%$
	IEC NINV	$0.05-2.00$	0.0	$\pm 5\%$
	IEC VINV	$0.05-2.00$	0.0	$\pm 5\%$
	IEC EINV	$0.05-2.00$	0.0	$\pm 5\%$
	IEC LINV	$0.05-2.00$	0.0	$\pm 5\%$
	ANSI MINV	$0.05-2.00$	0.0	$\pm 5\%$
	ANSI EINV	$0.05-2.00$	0.0	$\pm 5\%$
	Flat	$0.05-2.00$	0.0	$\pm 5\%$
	I_t	$0.05-2.00$	0.0	$\pm 5\%$
	I^2_t	$0.05-2.00$	0.0	$\pm 5\%$
Reset mode	Only available if IEC characteristics	$0.00-60.00$	$0.01 \times s$	$\pm 1\%$ resp. ± 10 ms
	IEC NINV	$0.00-60.00$	$0.01 \times s$	$\pm 1\%$ resp. ± 10 ms
	IEC VINV	$0.00-60.00$	$0.01 \times s$	$\pm 1\%$ resp. ± 10 ms
	IEC EINV	$0.00-60.00$	$0.01 \times s$	$\pm 1\%$ resp. ± 10 ms
	IEC LINV	$0.00-60.00$	$0.01 \times s$	$\pm 1\%$ resp. ± 10 ms
	Reset curves if ANSI characteristics	—	—	5%
	ANSI MINV	—	—	5%
	ANSI VINV	—	—	5%
	ANSI EINV	—	—	5%
	Flat	—	—	5%
	I_t	—	—	5%
	I^2_t	—	—	5%
	I^4_t	—	—	5%

Circuit Breaker Failure Protection 50BF

Description		Range	Step	Tolerance
I-CBF>	If the pick-up value is exceeded, the module/stage will be started.	$0.0-0.1 \times 1$	$0.01 \times I_n$	$\pm 1.5\%$ of the setting value resp. $1\% I_n$
Resetting ratio		$0.5\% \times I_n$	—	—
t-CBF	If the delay time is expired, an CBF alarm is given out.	—	—	$<+40$ ms
Operating time	Starting from I higher than $1.3 \times I-CBF >$	—	—	$<+40$ ms
Disengaging time		—	—	$<+40$ ms

Note

The tripping delay relates to the time between pickup and trip. The tolerance of the operating time relates to the time between the measured value has exceeded the threshold until the protection stage is alarmed.

Wiring Diagrams

EDR-3000

Connection Example Clockwise Rotating Field
EDR3000 => Terminal Markings X3.

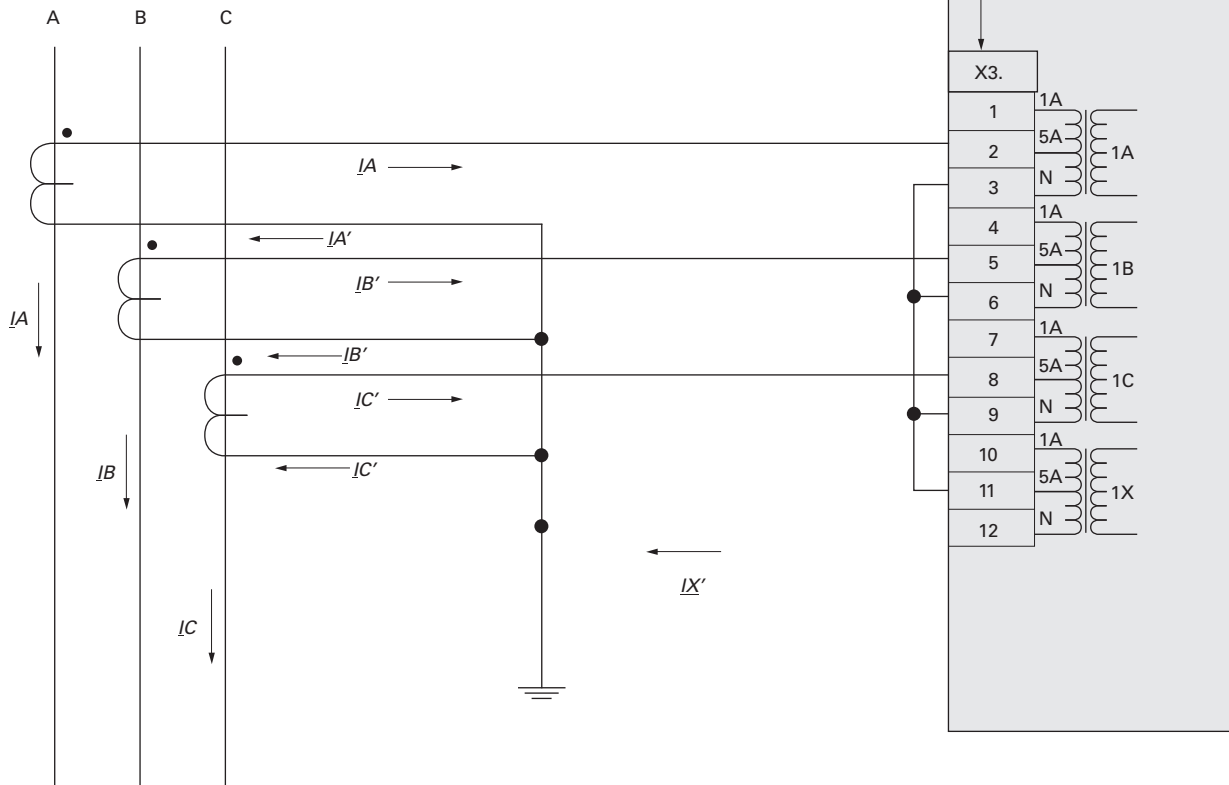

Three-Phase Current Measurement; I_{nom} Secondary = 5A
Ground Current Measuring via Residual Connection; I_{Gnom} Secondary = 5A

Dimensions

Approximate Dimensions in Inches (mm)

Drilling Pattern

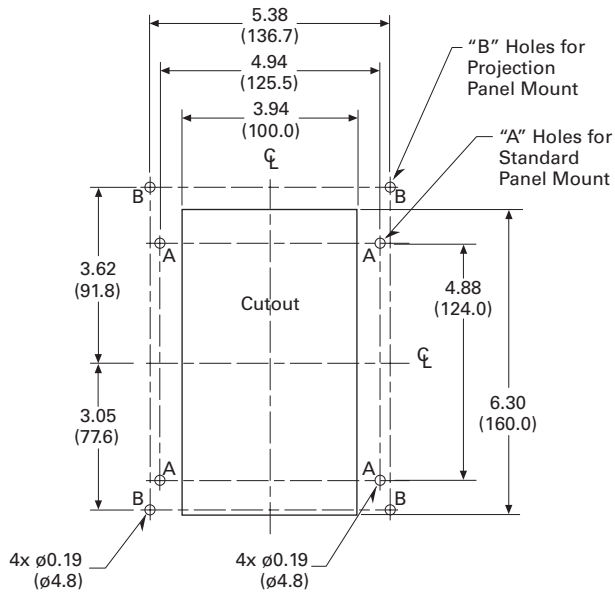

Projection Mounting

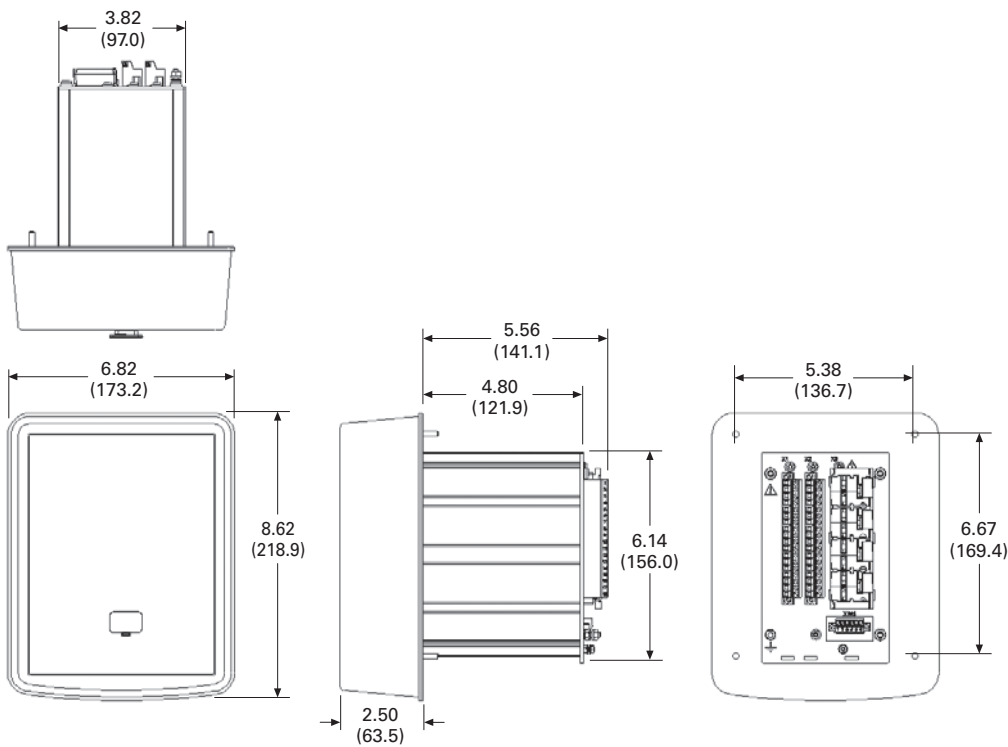

Approximate Dimensions in Inches (mm)

Standard Mounting

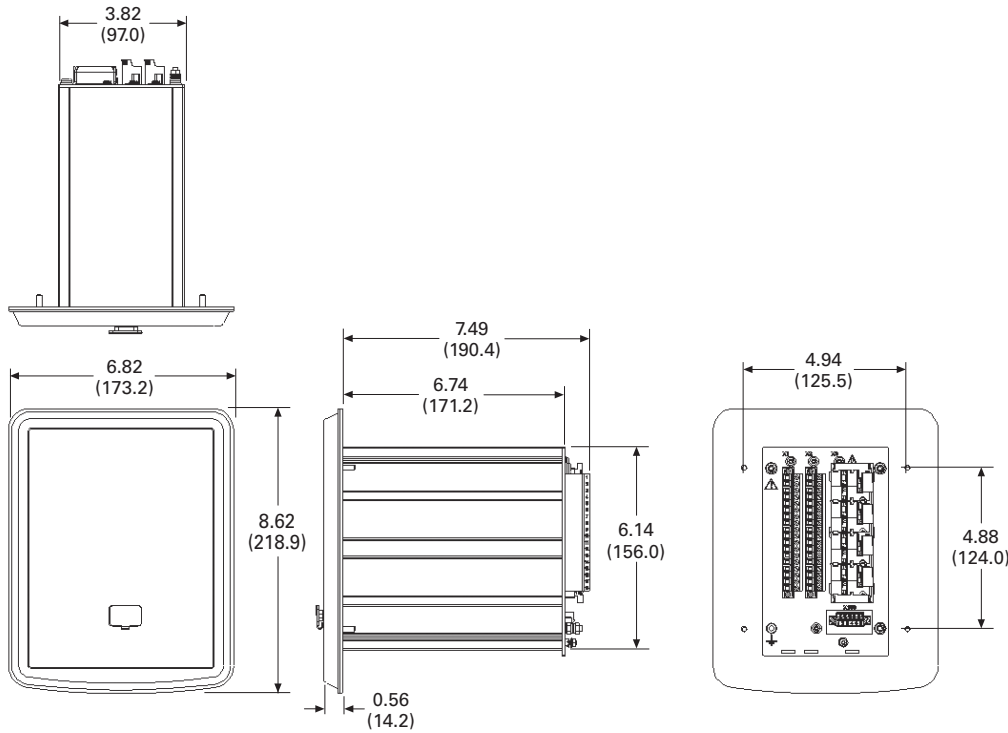

EDR-3000

Width	Height	Depth
6.82 (173.2)	8.62 (218.9)	7.49 (190.2) ①

EDR-3000 Housing B1

Width	Height	Depth	Shipping Weight Lbs (kg)
5.57 (141.5)	7.21 (183.0)	8.19 (208.0) ②	5.3 (2.4)

Notes

- ① Depth behind panel with projection mounted enclosure.
- ② Includes terminals.

ETR-4000



Contents

<i>Description</i>	<i>Page</i>
Product Selection Guide	V3-T9-158
FP-6000 Feeder Protection	V3-T9-162
FP-5000 Feeder Protection	V3-T9-172
FP-4000 Feeder Protection	V3-T9-180
MP-3000 Motor Protection	V3-T9-188
MP-4000 Motor Protection	V3-T9-198
MD-3000 Motor/Generator Differential Relay	V3-T9-204
Digitrip 3000	V3-T9-207
VR-300 Multifunctional Voltage Relay	V3-T9-217
DP-300 Current Differential Protection Relay	V3-T9-221
EDR-3000 Feeder Protection	V3-T9-226
ETR-4000 Transformer Protection Relay	
Features, Benefits and Functions	V3-T9-238
Catalog Number Selection	V3-T9-241
Technical Data and Specifications	V3-T9-241
Dimensions	V3-T9-248
Ground Fault Relay	V3-T9-250
Universal RTD Module	V3-T9-254
IQ 125 Volt DC Power Supply	V3-T9-258

ETR-4000 Transformer Protection Relay

Product Description

Eaton’s ETR-4000 transformer protection relay is a multi-functional, microprocessor-based relay for two winding transformers of all voltage levels. The ETR-4000 provides phase and ground percentage restrained differential protection using a variable dual slope characteristic with phase, negative, residual and neutral overcurrent elements for backup protection. It can also be used to provide restrained differential protection to large motors and generators.

The ETR-4000 has eight current inputs rated for either 5 amperes or 1 ampere to monitor both sides of the transformers. The CTs can be connected in wye in both sides of the transformer; the relay automatically compensates for the connection of the transformer and CT mismatch errors.

The maintenance mode password protected soft key, can be used for arc flash mitigation to change to an alternate settings group, set to have instantaneous elements only.

An integral keypad and display is provided for direct user programming and retrieval of data without the need of a computer. 14 programmable LEDs provide quick indication of relay status.

A front port is provided for direct computer connection. An RS-485 communication port on the back is standard for local area networking using Modbus-RTU. An optional Ethernet port and protocols are available.

Flash memory is used for the programming and all settings are stored in nonvolatile memory. The relay allows for four preprogrammed setting groups which can be activated through software, the display or a contact input.

The ETR-4000 transformer protection relay has mass memory for data storage and a real-time clock with 1 ms time resolution. The relay will log 300 sequence of event records, 20 detailed trip logs, minimum/maximum values, load profiles, breaker wear information and oscillography data.

The ETR-4000 has eight programmable binary inputs, 4 normally opened and 4 Form C heavy duty outputs and one Form C signal alarm relay. It can be powered from 19 Vdc to 300 Vdc or 40 Vac to 250 Vac auxiliary power.

Features, Benefits and Functions

- Flexible phase and ground differential protection for two winding transformers, large motors and generators
- Complete protection and control in a single compact case to reduce panel space, wiring and costs
- Integral test function reduces maintenance time and expense
- Zone selective interlocking improves coordination and tripping time, and saves money compared to a traditional bus differential scheme
- Reduce troubleshooting time and maintenance costs. Trip and event recording in non-volatile memory provides detailed information for analysis and system restoration. 6000 cycles of waveform capture aids in post fault analysis (viewable using PowerPort-E software)
- Minimum replacement time. Removable terminal blocks ideal for industrial environments
- Front RS-232 port and PowerPort-E software provides local computer access and user-friendly Windows-based interface for relay settings, configuration and data retrieval
- Breaker open/close from relay faceplate or remotely via communications
- Fast an easy troubleshooting, improved maintenance procedures and increased device security. Provides detailed traceability for system configuration changes
- Relays self-diagnostics and reporting improves uptime and troubleshooting
- Breaker trip circuit monitoring improves the reliability of the breaker operation

Features

Protection Features

- Dual-slope percentage restrained current differential with magnetizing inrush and overexcitation blocking (87R)
- Unrestrained current differential (87H)
- Restricted ground fault/ Ground Differential (87GD)
- Phase overcurrent (elements can be assigned to either side of the transformer):
 - Four instantaneous elements with timers (50P[1], 50P[2], 50P[3] and 50P[4])
 - Four inverse time overcurrent elements (51P[1], 51P[2], 51P[3] and 51P[4])
 - 11 standard curves
 - Inrush Blocking
 - Instantaneous or time delay reset
- Negative sequence phase overcurrent (elements can be assigned to either side of the transformer):
 - Two inverse time overcurrent elements (51Q[1] and 51Q[2])
 - 11 standard curves
 - Instantaneous or time delay reset
- Ground overcurrent (elements can be assigned to either side of the transformer):
 - Two instantaneous measured elements with timers (50X[1] and 50X[2])
 - Two instantaneous calculated elements with timers (50R[1] and 50R[2])
 - Two inverse time overcurrent measured elements (51X[1] and 51X[2])
 - Two inverse time overcurrent calculated elements (51R[1] and 51R[2])
 - 11 standard curves
 - Instantaneous or time delay reset

- Two breaker failure elements (50BF[1] and 50BF[2])
- Phase transformer overload protection (49)
- Switch onto fault protection
- Cold load pickup
- Zone interlocking for bus protection (87B)

Metering Features

- Amperes: positive, negative and zero sequence
- Ampere demand
- Current phase angles
- % THD I
- Magnitude THD I
- Minimum/maximum recording
- Trending
- RTD Temperatures with remote URTD

Monitoring Features

- Trip coil monitor for both primary and secondary breakers
- Breaker wear primary and secondary (accumulated interrupted current)
- Oscillography (6000 cycles total)
- Fault data logs (up to 20 events)
- Sequence of events report (up to 300 events)
- Clock (1 ms time stamping)

Control Functions

- Breaker open/close both breakers
- Remote open/close
- Programmable I/O
- Programmable LEDs
- Multiple setting groups
- Cold load pickup
- CT supervision

Communication Features

- Local HMI
- Password protected
- Addressable
- IRIG-B
- Local communication port
- Remote communication port:
 - RS-232
 - RS-485

- Protocols:
 - Modbus-RTU
 - Modbus-TCP (Optional)
- Configuration software

Protection and Control Functions

Eaton's ETR-4000 transformer protection relay has been designed for maximum user flexibility and simplicity. The ETR-4000 is suitable for application on small, medium and large two winding power transformers.

Multiple current inputs are used to provide primary protection, control and back-up protection of transformers, including current differential, restricted ground differential and overcurrent protection.

Dual-Slope Percent Differential Protection

The primary protective element for transformer protection is the percent differential element, which compares the current entering the primary and leaving the secondary of the transformer. The ETR-4000 has built in compensation for the turns-ratio and the phase shift of the transformer, so it's not necessary to compensate for the transformer connection by the connection of the CTs.

The current differential element looks at the vector difference between the current entering and leaving the zone of protection. If the difference exceeds a pre-determined amount, the element will operate.

The operating characteristic of the percent differential element is a dual-slope characteristic to accommodate for CT saturation and CT errors.

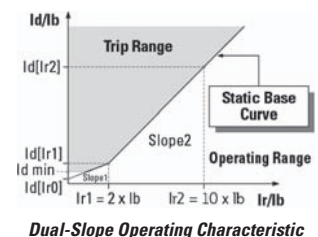

Harmonic Restraints

There are certain conditions like energizing one side of the transformer with the other side de-energized (inrush currents) or the paralleling of two transformers (sympathetic currents) that can create false differential currents. These differential currents if not recognized can cause a false trip; in the case of inrush conditions or sympathetic currents the differential current is characterized by a heavy content of 2nd and 4th harmonic currents. The percentage differential element is desensitized either permanently (stationary conditions) or temporarily (transient conditions), whenever the 2nd or 4th harmonic exceed the value programmed into the relay.

Another condition that can create a false differential current is a sudden change of voltage or frequency, that can put the transformer in an overexcitation state. In this case there is high content of 5th harmonic currents. The percentage differential element is also desensitized when the 5th harmonic content exceeds a predefined value.

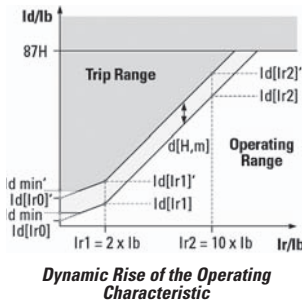

Dynamic Rise of the Operating Characteristic

Unrestrained Differential

An unrestrained differential element is provided for fast tripping on heavy internal faults to limit catastrophic damage to the transformer and minimize risks to the remainder of the power system.

Restricted Ground Fault

Ground differential protection is applied to transformers having impedance grounded wye windings. It is intended to provide sensitive ground fault detection for low magnitude fault currents, which would not be detected by the main percent differential element.

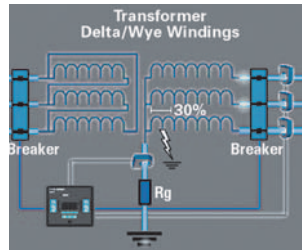

Restricted Ground Fault

Overcurrent Elements

The ETR-4000 can be used to provide backup for transformer and adjacent power system equipment. Instantaneous overcurrent elements can be used for fast clearing of severe internal or external (through) faults. Time overcurrent protection elements per winding allow coordinating with the adjacent protection zones and acting as a backup protection. There are 11 user-selectable inverse-time overcurrent curve characteristics. The user can select from the ANSI, IEC or thermal curve families and can select instantaneous or time delay reset characteristics.

Negative Sequence Overcurrent

Since this element does not respond to balanced load or three-phase faults, the negative-sequence overcurrent element may provide the desired overcurrent protection. This is particularly applicable to delta-wye grounded transformers where only 58% of the secondary p.u. phase-to-ground fault current appears in any one primary phase conductor. Backup protection can be particularly difficult when the wye is impedance grounded. A negative-sequence element can be used in the primary supply to the transformer and set as sensitively as required to protect for secondary phase-to-ground or phase-to-phase faults. This element should be set to coordinate with the low-side phase and ground relays for phase-to-ground and phase-to-phase faults. The negative sequence element must also be set higher than the negative-sequence current due to unbalanced loads.

Breaker Failure

The ETR-4000 transformer protection relay includes two breaker failure (50BF, 62BF) elements that can be initiated from either an internal or external trip signal. These are independent elements that can be used to operate a lockout relay or trip an upstream breaker. The timer must be longer than the breaker operating time and the protective function reset times.

Maintenance Mode

The Maintenance Mode can improve safety by providing a simple and reliable method to reduce fault clearing time and lower incident energy levels at energized panels. The Maintenance Mode allows the user to switch to more sensitive settings via a password protected soft key, communications or via a digital input while maintenance work is being performed at an energized panel or device. The more sensitive settings provide greater security for maintenance personnel and helps reduce the possibility of injury.

Monitoring and Metering

Sequence of Events Records

The ETR-4000 protection relay records a maximum of 300 events associated with the relay. An event is classified as a change of state as detected by the relay. These include relay pickups, dropouts, trips, contact closure, alarms, setting changes and self-diagnostic failures. Each event is date and time stamped to a 1 ms resolution. The events are stored in a FIFO in chronological order.

Trip Log

The ETR-4000 protection relay will store a maximum of 20 trip records in a FIFO trip log. Each trip record will be date and time stamped to a 1 ms resolution. The trip log record will include information on the type of fault, protection elements that operated, fault location and currents at the time of the fault.

Waveform Capture

The ETR-4000 transformer protection relay provides oscillography-recording capabilities. The relay will record all measured signals along with the binary signals of pickup, trip, logic and contact closures. The ETR-4000 relay can record up to 6000 cycles of data. The number of records is proportional to the size of each record; the maximum size per record is 600 cycles. The waveform capture is initiated by up to 8 different triggers; it can also be generated manually through the display or via communications.

Integral User Interface

The front panel user interface has a 128 x 64 pixel LCD display with background illumination for wide angle viewing in all light conditions. 14 programmable LEDs provide quick and easy visual display of power on, mode of operation, alarm and trip indication. Soft keys are provided for operation mode selection, scrolling through data and settings. In addition, the relay settings and test functions are password protected.

Programmable I/O

The ETR-4000 transformer protection relay provides heavy-duty, trip-rated, 4 normally open and 4 Form C contacts. Two isolated inputs can be used for monitoring the trip circuits. One Form C contact is dedicated to the relay failure alarm function and is operated in a normally energized (fail-safe) mode. There are eight user-configurable discrete inputs that accept a wet contact and can operate through a wide range of power. Each input and output is user-programmable for maximum application flexibility.

Communication Software

Eaton provides two types of communication software. The first is PowerPort-E. It runs on a PC or laptop for easy access to a single relay to change set points or configuration and to view metered values and stored data. PowerPort-E is free and can be downloaded from the Eaton Web site at the following URL:

<http://www.eaton.com/pr>

The second package is Power Xpert Software. Power Xpert Software is a power management software package that is designed for continuous, remote monitoring of many devices. It provides additional functions such as billing, trending and graphics. Contact your local Eaton representative for more information on Power Xpert Software.

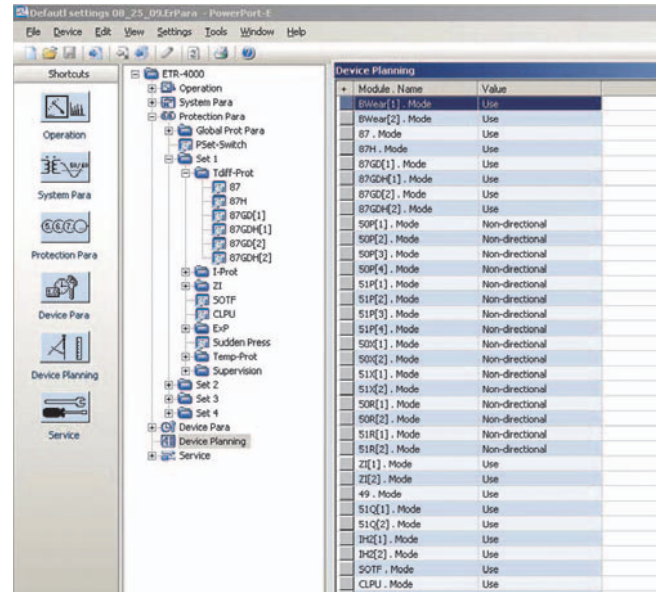

PowerPort-E- ETR-4000 Device Planning

Standards and Certifications**Design Standards**

- Generic Standard:
 - EN 61000-6-2
 - EN 61000-6-3
- Product Standard:
 - IEC 60255-6
 - EN 50178
 - UL 508 (Industrial Control Equipment)
 - CSA C22.2 No. 14-95 (Industrial Control Equipment)
 - ANSI C37.90
- UL listed file: E217753



Catalog Number Selection

The catalog number identification chart defines the electrical characteristics and operation features included in the ETR-4000. For example, if the catalog number were ETR-3000A0BA1, the device would have the following:

ETR-4000

(A)–8 Digital Inputs, 9 Output Relays

(0)–5A/1A phase and ground CTs, Power Supply Range: 19-300 Vdc, 40–250 Vac

(B)–Modbus-RTU (RS-485)

(A)–Without Conformal Coating

(1)–Projection Panel Mount

ETR-4000 Eaton Transformer Protection Relay

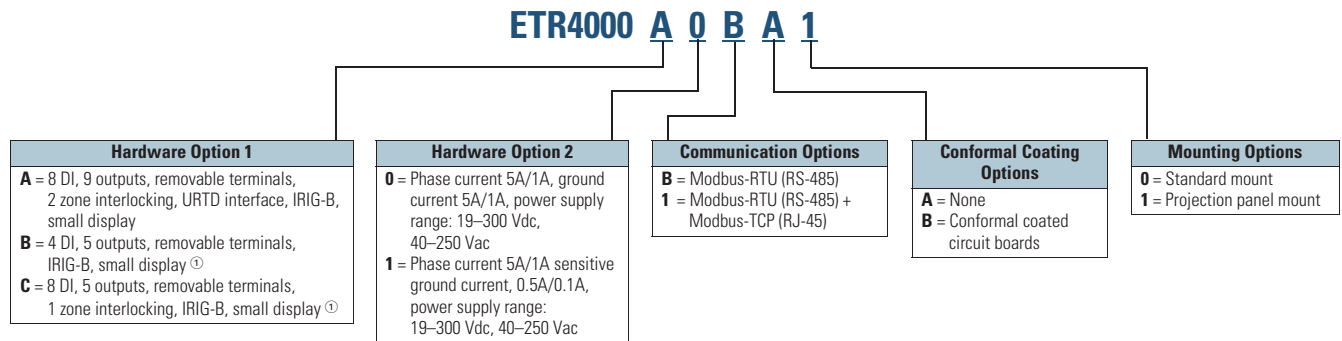

Technical Data and Specifications

Climatic Environmental Conditions

- Storage temperature: –22°F to 158°F (–30°C to +70°C)
- Operating temperature: –40°F to 140°F (–40°C ② to +60°C)
- Permissible humidity at ann. average: <75% rel. (on 56d up to 95% rel.)
- Permissible installation altitude:
 - 6,561.67 ft (<2,000m) above sea level
 - If 13,123.35 ft (4,000m) altitude applies, a changed classification of the operating and test voltages may be necessary

Degree of Protection EN 60529

- HMI front panel with seal: IP54
- Rear side terminals: IP30

Routine Test

- Insulation test according to IEC 60255-5: All tests to be carried out against ground and other input and output circuits
- Aux. voltage supply, digital inputs: 2.5 kV (eff.)/50 Hz
- Current measuring inputs, signal relay outputs: 2.5 kV (eff.)/50 Hz
- Voltage measuring inputs: 3.0 kV (eff.)/50 Hz
- All wire-bound communication interfaces: 1.5 kV DC

Housing

- Material, housing: Aluminum extruded section
- Material, front panel: Aluminum/foil front
- Mounting position: Horizontal (±45° around the X-axis must be permitted)

Plug-in Connector with Integrated Short-Circuiter (Conventional Current Inputs)

- Nominal current: 1A and 5A
- Continuous loading capacity: 4 x I_n/continuously
- Overcurrent withstand:
 - 30 x I_n/10s
 - 100 x I_n/1s
 - 250 x I_n/10 ms (1 half-wave)
- Screws: M4, captive type acc. to VDEW
- Connection cross sections:
 - 2 x AWG 14 (1 x or 2 x 2.5 mm²) with wire end ferrule
 - 2 x AWG 12 (1 x or 2 x 4.0 mm²) with ring cable sleeve or cable sleeve
 - 2 x AWG 10 (1 x or 2 x 6 mm²) with ring cable sleeve or cable sleeve

Control Power Supply

- Aux. voltage: 24–270 Vdc/48–230 Vac (–20/+10%)
- Buffer time in case of supply failure: ≥ 50 ms at minimal aux. voltage interrupted communication is permitted
- Maximum permissible making current:
 - 18A peak value for <0.25 ms
 - 12A peak value for <1 ms
- The voltage supply must be protected by a fuse of:
 - 2.5A time-lag miniature fuse approx. 0.2 x 0.8 in. (5 x 20 mm) according to IEC 60127
 - 3.5A time-lag miniature fuse approx. 0.25 x 1.25 in. (6.3 x 32 mm) according to UL 248-14

Notes

- Consult factory for the availability of 4 Inputs/5 Outputs, 8 Inputs/5 Outputs and sensitive ground.
- Display will stop working at –20°C.

Power Consumption

- Power supply range: 19–300 Vdc
 - Power consumption in idle mode—7W
 - Maximum power consumption—13W
- Power supply range: 40–250 Vac (for frequencies of 40–70 Hz)
 - Power consumption in idle mode—7W
 - Maximum power consumption—13W

Real-Time Clock

- Running reserve of the real-time clock: 1 year minimum

Display

- Display type: LCD with LED background illumination
- Resolution graphics display: 128 x 64 pixel
- LED type: Two colored—red/green
- Number of LEDs, housing B2: 15

Digital Inputs

- Maximum input voltage: 300 Vdc/270 Vac
- Input current: <4 mA
- Reaction time: <20 ms
- Fallback time: <30 ms

(Safe state of the digital inputs)

- 4 switching thresholds: $U_n = 24$ Vdc, 48 Vdc, 60 Vdc, 110 Vac/Vdc, 230 Vac/Vdc
- $U_n = 24$ Vdc
 - Switching threshold 1 ON: Min. 19.2 Vdc
 - Switching threshold 1 OFF: Max. 9.6 Vdc
- $U_n = 48$ –60 Vdc
 - Switching threshold 2 ON: Min. 42.6 Vdc
 - Switching threshold 2 OFF: Max. 21.3 Vdc

- $U_n = 110/120$ Vac/Vdc
 - Switching threshold 3 ON: Min. 88.0 Vdc/88.0 Vac
 - Switching threshold 3 OFF: Max. 44.0 Vdc/44.0 Vac
- $U_n = 230/240$ Vac/Vdc
 - Switching threshold 4 ON: Min. 184 Vdc/184 Vac
 - Switching threshold 4 OFF: Max. 92 Vdc/92 Vac
- Terminals: Screw-type terminal

Current and Ground Current Measurement

- Nominal currents: 1A/5A
- Max. measuring range:
 - Up to $40 \times I_n$ (phase currents)
 - Up to $25 \times I_n$ (ground current standard)
 - Up to $2.5 \times I_n$ (ground current sensitive)
- Continuous loading capacity: $4 \times I_n$ /continuously
- Overcurrent proof:
 - $30 \times I_n/10$ s
 - $100 \times I_n/1$ s
 - $250 \times I_n/10$ ms (1 half-wave)
- Power consumption:
 - Phase current inputs
 - At $I_n = 1$ A
S = 0.15 MVA
 - At $I_n = 5$ A
S = 0.15 MVA
 - Ground current input
 - At $I_n = 1$ A
S = 0.35 MVA
 - At $I_n = 5$ A
S = 0.35 MVA
- Frequency range: 50 Hz/60 Hz $\pm 10\%$
- Terminals: Screw-type terminals with integrated short-circuiters (contacts)

Relay Outputs

- Continuous current: 5A AC/DC
- Maximum make current:
 - 25A AC/25A DC up to 30V for 4s
 - 30A/230 Vac according to ANSI IEEE Std. C37.90-2005
 - 30A/250 Vdc according to ANSI IEEE Std. C37.90-2005
- Maximum breaking current:
 - 5A AC up to 125 Vac
 - 5A DC up to 30V (resistive)
 - 0.3A DC at 300V
- Maximum switching voltage: 250 Vac/250 Vdc
- Switching capacity: 1250 VA
- Contact type: changeover contact or normally open contact
- Terminals: Screw-type terminals

Supervision Contact (SC)

- Continuous current: 5A at 120/240 Vac or 30 Vdc
- Maximum switch-on current: 15A at 120/240 Vac or 30 Vdc (max. 4s)
- Maximum breaking current:
 - 5A at 120/240 Vac or 30 Vdc
 - 0.4A at 125 Vdc
- Contact type: 1 changeover contact
- Terminals: Screw-type terminals

Time Synchronization IRIG

- Nominal input voltage: 5V
- Connection: Screw-type terminals (twisted pair)

Front Interface RS-232

- Baud rates: 115,200 baud
- Handshake: RTS and CTS
- Connection: 9-pole D-Sub plug

RS-485

- Master/slave: Slave
- Connection: 6 screw-clamping terminals RM 138 MIL (3.5 mm) (terminating resistors internal)

Zone Interlocking

- Nominal input level: 5V
- Nominal output level: 5V
- Connection: Screw-type terminals (twisted pair)

Standards**High Voltage Tests (IEC 60255-6)**

- High frequency interference test:
 - IEC 60255-22-1 Class 3
 - Within one circuit—1 kV/2s
 - Circuit to ground—2.5 kV/2s
 - Circuit to circuit—2.5 kV/2s
- Insulation voltage test:
 - IEC 60255-5, EN 50178
 - All circuits to other circuits and exposed conductive parts: 2.5 kV (eff.)/50 Hz, 1 min.
 - Except interfaces: 1.5 kV DC, 1 min.
 - Voltage measuring input: 3 kV (eff.)/50 Hz, 1 min.
- Impulse voltage test:
 - IEC 60255-5: 5 kV/0.5J, 1.2/50 μ s

EMC Immunity Tests

- Fast transient disturbance immunity test (burst):
 - IEC 60255-22-4: Power supply, mains inputs— ± 4 kV, 2.5 kHz
 - IEC 61000-4-4 Class 4: Other in- and outputs— ± 2 kV, 5 kHz (coupling network)
 - ANSI C37.90.1: ± 4 kV, 2.5 kHz (coupling clamp)
- Surge Immunity Test:
 - IEC 61000-4-5 Class 4
 - Within one circuit—2 kV
 - Circuit to ground—4 kV
- Electrical discharge immunity test:
 - IEC 60255-22-2: Air discharge—8 kV
 - IEC 61000-4-2 Class 3: Contact discharge—6 kV
- Radiated radio frequency electromagnetic field immunity test
 - IEC 61000-4-3: 26 MHz – 80 MHz—10 V/m
 - Class X: 80 MHz–1 GHz—35 V/m
 - ANSI C37.90.2: 1 GHz–3 GHz—10 V/m
- Immunity to conducted disturbances induced by radio frequency fields:
 - IEC 61000-4-6 Class 3: 10 V
- Power frequency magnetic field immunity test:
 - IEC 61000-4-8: Continues—30 A/m
 - Class 4: 3 sec—300 A/m

EMC Emission Tests

- Radio interference suppression test:
 - IEC/CISPR11—Limit value class B
- Radio interference radiation test:
 - IEC/CISPR11—Limit value class B

Environmental Tests
Classification

- IEC 60068-1: Climatic—0/055/56
- IEC 60721-3-1:
 - Classification of ambient conditions (storage)—1K5/1B1/1C1L/1S1/1M2 but min. -13°F (-25°C)
- IEC 60721-3-2: Classification of ambient conditions (transportation)—2K3/2B1/2C1/2S1/2M2
- IEC 60721-3-3: Classification of ambient conditions (Stationary use at weather protected locations)—3K6/3B1/3C1/3S1/3M2 but min. 32°F (0°C) and 3K8H for 2h

Test ad: Cold

- IEC 60068-2-1:
 - Temperature— -4°F (-20°C)
 - Test duration—16h

Test Bd: Dry heat

- IEC 60068-2-2:
 - Temperature— 131°F (55°C)
 - Relative humidity— $<50\%$
 - Test duration—72h

Test cab: Damp heat (steady state)

- IEC 60068-2-78:
 - Temperature— 104°F (40°C)
 - Relative humidity—93%
 - Test duration—56d

Test Db: Damp heat (cyclic)

- IEC 60068-2-30:
 - Temperature— 131°F (55°C)
 - Relative humidity—95%
 - Cycles (12 + 12-hour)—2

Mechanical Tests
Test Fc: Vibration response test

- IEC 60068-2-6, IEC 60255-21-1, Class 1:
 - Displacement: (10 Hz–59 Hz)—0.0014 in. (0.035 mm)
 - Acceleration: (59 Hz–150 Hz)—0.5 gn
 - Number of cycles in each axis: 1

Test Fc: Vibration endurance test

- IEC 60068-2-6, IEC 60255-21-1, Class:
 - Acceleration: (10 Hz–150 Hz)—1.0 gn
 - Number of cycles in each axis: 20

Test Ea: Shock test

- IEC 60068-2-27, IEC 60255-21-2, Class 1
 - Shock response test: 5 gn, 11 ms, 3 impulses in each direction
 - Shock resistance test: 15 gn, 11 ms, 3 impulses in each direction

Test Eb: Shock endurance test

- IEC 60068-2-29, IEC 60255-21-2, Class 1
 - Shock endurance test: 10 gn, 16 ms, 1000 impulses in each direction

Test Fe: Earthquake test

- IEC 60068-3-3, KTA 3503, IEC 60255-21-3, Class 2
 - Single axis earthquake vibration test:
 - 3–7 Hz: Horizontal 0.394 in. (10 mm), 1 cycle each axis
 - 7–35 Hz Horizontal: 2 gn, 1 cycle each axis

Tolerances
Tolerances of the Real - Time Clock

- Resolution: 1 ms
- Tolerance:
 - <1 minute/month (68°F [$+20^{\circ}\text{C}$])
 - $<\pm 1$ ms if synchronized via IRIG-B

Tolerances of the Measured Value Acquisition

Phase and ground current measuring

- Maximum measuring range:
 - Up to $40 \times I_n$ (phase currents)
 - Up to $25 \times I_n$ (ground current standard)
 - Up to $2.5 \times I_n$ (earth current sensitive)

Note: The precision does not depend on the nominal value but is referenced to 100 mA (with $I_n = 1$ A) respectively, 500 mA (with $I_n = 5$ A)

- Frequency range: 50 Hz / 60 Hz $\pm 10\%$
- Accuracy: Class 0.5
- Amplitude Error if $I < 1 I_n$: $\pm 0.5\%$ of the rated value
- Amplitude Error if $I > I_n$: $\pm 0.5\%$ of the measured value
- Amplitude Error if $I > 2 I_n$: $\pm 1.0\%$ of the measured value
- Resolution: 0.01A
 - Harmonics: Up to 20% 3rd harmonic $\pm 1\%$
 - Up to 20% 5th harmonic $\pm 1\%$
- Frequency influence: $< \pm 2\%$ / Hz in the range of ± 5 Hz of the parametrized nominal frequency
- Temperature influence: $< \pm 1\%$ within the range of $+32^{\circ}\text{F}$ to $+140^{\circ}\text{F}$ (0°C to $+60^{\circ}\text{C}$)

Protection Elements Tolerances

Notice: The tripping delay relates to the time between alarm and trip. The tolerance of the operating time relates to the time between when the measured value has exceeded the threshold until the protection element is picked up.

Description		Tolerance	
Differential Protection Stages: 87[x]			
Id > 0.1 Id[x]		±3% of the setting value resp. 1% I _n	
Operating time	Id > 0.3 x I _n	< 35 ms	
	Id > 0.5 x I _n	< 25 ms	
	Id > 1.5 x I _n	< 20 ms	
Ground Differential Protection Stages: 87GD[x]			
Id > 0.1 Id[x]		±3% of the setting value resp. 1% I _n	
Operating time	I _{de} > 0.3 x I _n	< 35 ms	
	I _{de} > 0.5 x I _n	< 25 ms	
	I _{de} > 1.5 x I _n	< 20 ms	
Overcurrent Protection Elements: 50P[x], 51P[x]			
Pickup		±1.5% of the setting value resp. 1% I _n	
Resetting ratio		97% or 0.5% x I _n	
t		DEFT ±1% resp. ±10 ms	
Operating time	Starting from I higher than 1.1 x I>	<+35 ms	
Disengaging time		<+45 ms	
t-Multiplier		±5%	
		IEC NINV	
		IEC VINV	
		IEC EINV	
		IEC LINV	
		ANSI MINV	
		ANSI VINV	
		ANSI EINV	
		Flat	
		It	
		I ² t	
		I ⁴ t	
	Reset Mode		±1% resp. ±10 ms
			IEC NINV
			IEC VINV
			IEC EINV
		IEC LINV	
		5%	
		ANSI MINV	
		ANSI VINV	
		ANSI EINV	
		Flat	
		It	
		I ² t	
		I ⁴ t	

Description		Tolerance	
Ground Current Elements: 50G[x], 50N[x], 51G[x], 51N[x]			
Pickup		±1.5% of the setting value resp. 1% I _n	
Resetting ratio		97% or 0.5% x I _n	
t		DEFT	
		±1% resp.	
		±10 ms	
Operating time	Starting from IE Higher than 1.1 x IE>	<+35 ms	
Disengaging time		<+45 ms	
t-Multiplier		±5%	
		IEC NINV	
		IEC VINV	
		IEC EINV	
		IEC LINV	
		ANSI MINV	
		ANSI VINV	
		ANSI EINV	
		Flat	
		It	
		I ² t	
		I ⁴ t	
	Reset mode		IEC characteristics
			IEC NINV
			IEC VINV
			IEC EINV
		IEC LINV	
		5%	
		Reset curves if ANSI characteristics	
		ANSI MINV	
		ANSI VINV	
		ANSI EINV	
		Flat	
		It	
		I ² t	
		I ⁴ t	
Thermal Replica: ThR			
I _b		±2% of the setting value Resp. 1% I _n	
K			
Pickup ThR		±1.5 % of the setting value	

Description	Tolerance
Unbalanced Load: 51Q[x]	
I _{2>}	±2% of the setting value resp. 1% I _n
Resetting ratio	97% or 0.5% x I _n
t	DEFT
	±1% resp.
Tripping delay time (DEFT)	±10 ms
Operating time	Starting from I ₂ higher than 1.3 x I _{2>} <+60 ms
Release time	<+40 ms
k	±5% INV
T-cool	±5% INV
Inrush Supervision IH2 ①	
IH2/I _n	±1% I _n
Resetting ratio	1% x I _n or 5% x IH2

Description	Tolerance
Breaker Failure Protection 50BF	
I-BF>	±1.5% of the setting value resp. 1% I _n
Resetting ratio	t-BF ±1% resp.
	±10 ms
Operating time	Starting from I Higher than 1.3 x I-BF> <+40 ms
Disengaging time	<+40 ms
Trip Circuit Monitoring TCM	
t-TCM	±1% resp
	±10 ms.
Current Transformer Supervision CTS	
Delta	±2% of the setting value resp. 1.5% I _n
Resetting ratio	94%
t	±1% resp. ± 10 ms

Wiring Diagrams

Typical AC Connections Delta-Wye Transformer with Wye CTs and Neutral CT

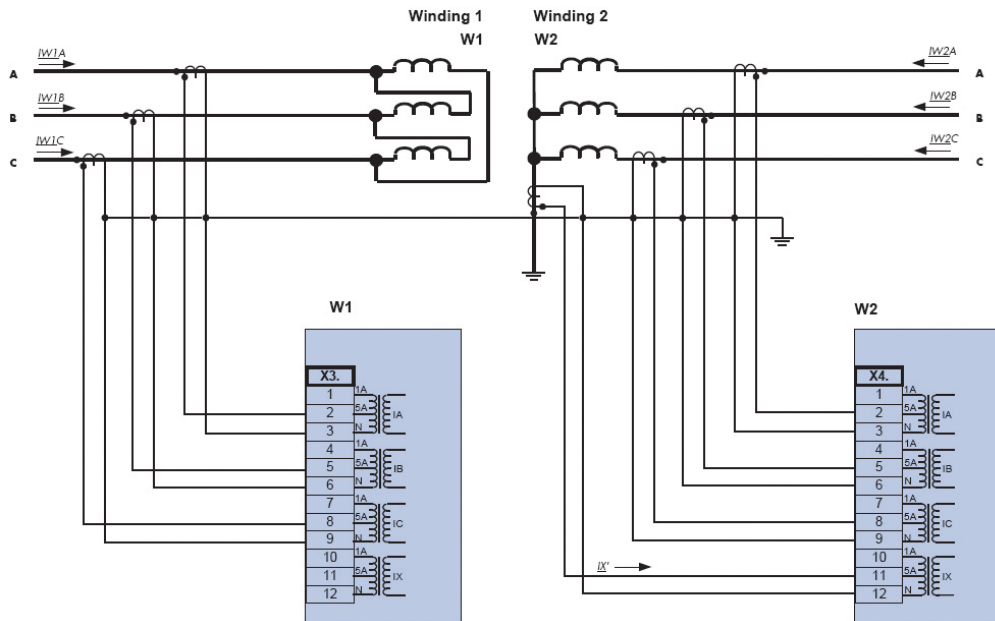

Note

① Inrush supervision is possible, if the fundamental Harmonic > 0.1xI_n and 2nd Harmonic > 0.01xI_n.

Typical One-Line Diagram

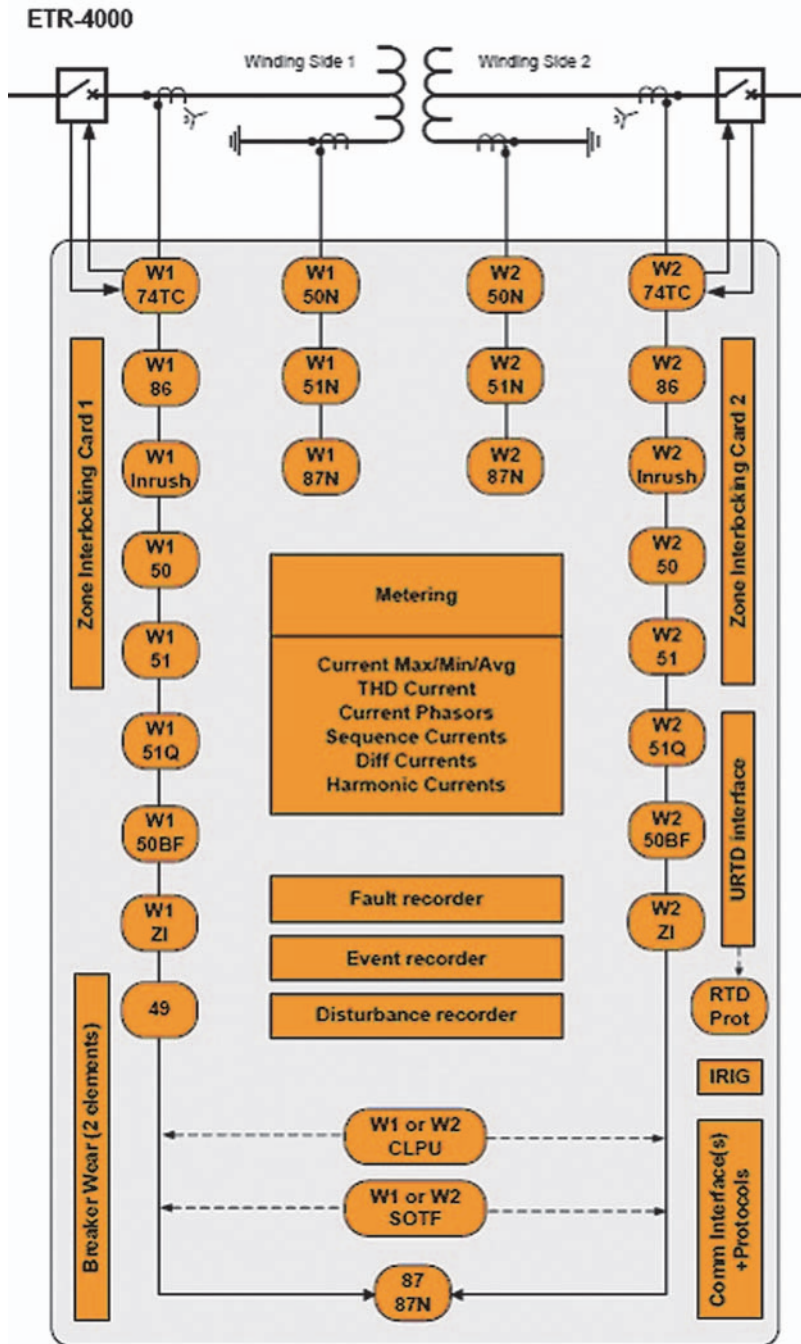

Typical Control Diagram

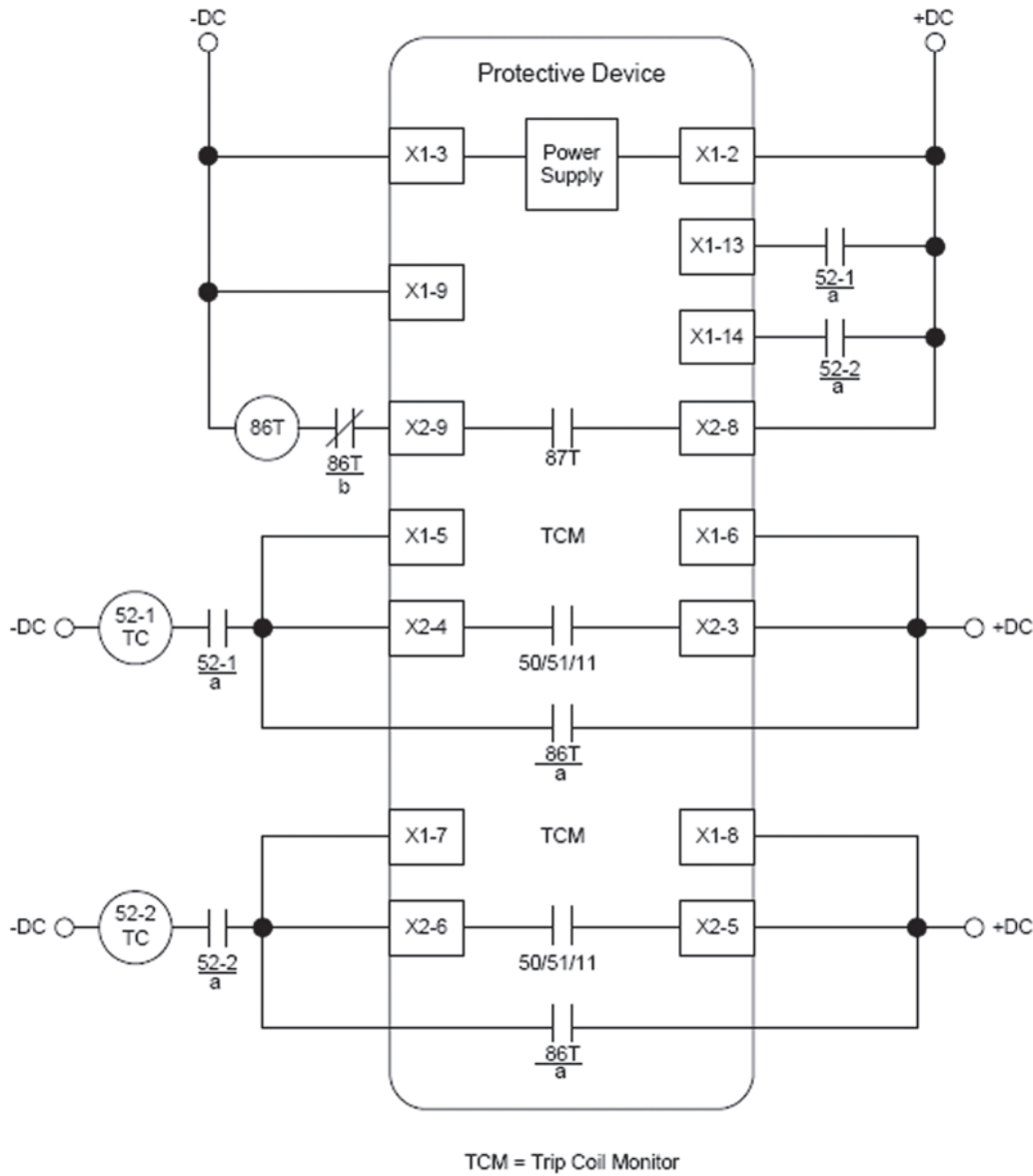

Dimensions

Approximate Dimensions in Inches (mm)

Drilling Plan

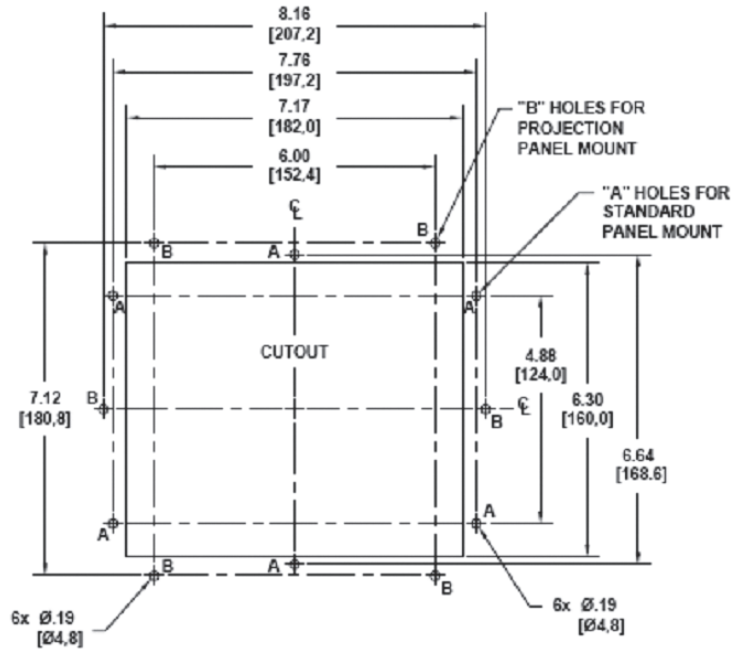

9

Projection Mount Front and Side Views

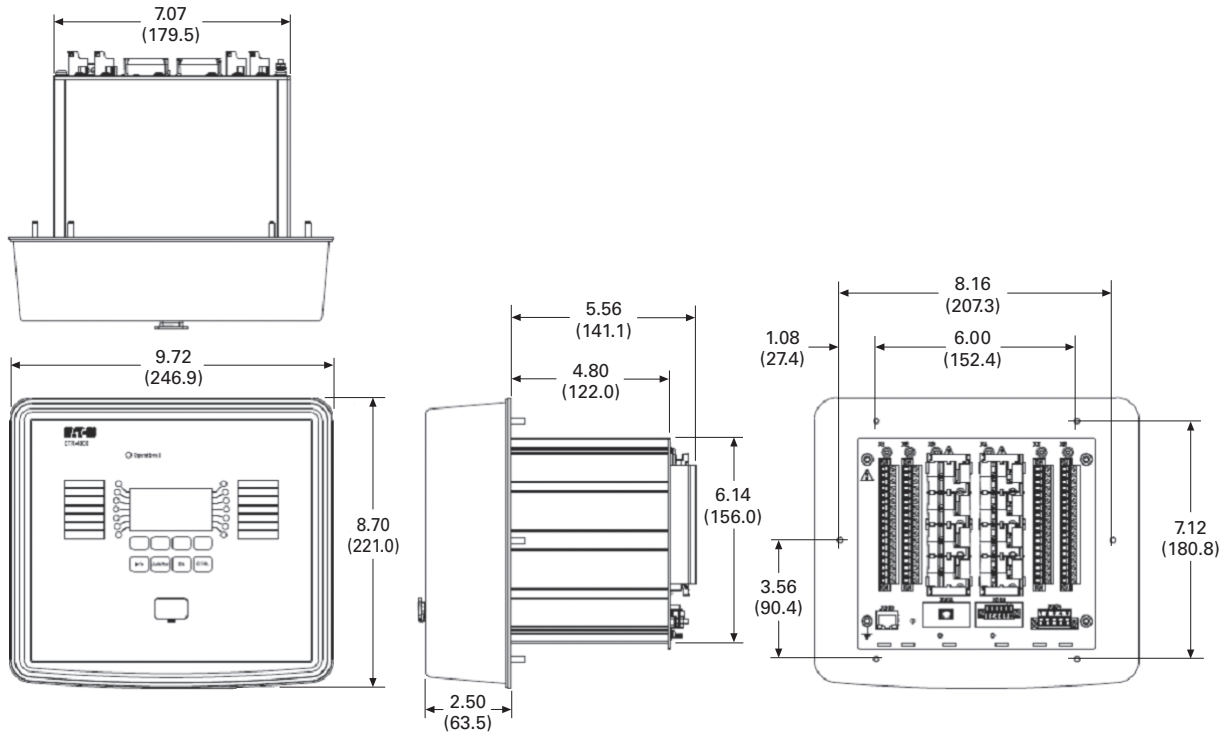

Approximate Dimensions in Inches (mm)

Standard Mount Front and Side Views

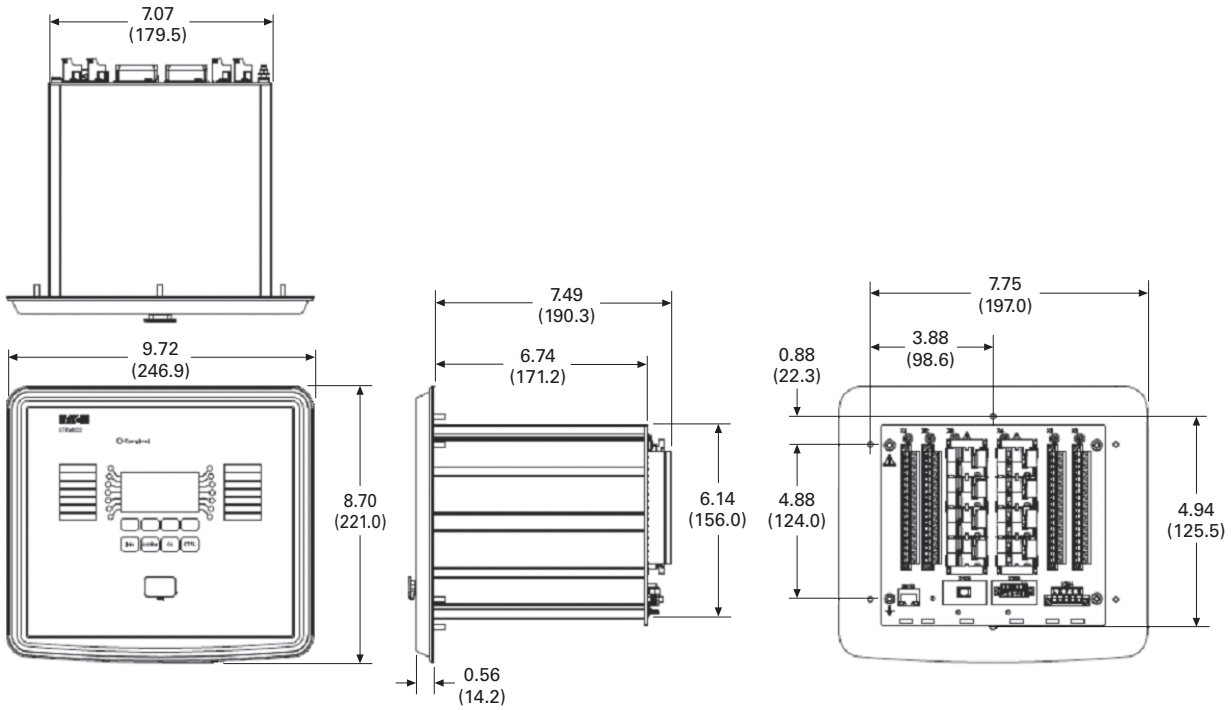

ETR-4000 Housing B2

Width	Height	Depth ^①	Shipping Weight Lbs (kg)
6.81 (173.0)	8.37 (212.7)	8.19 (208.0)	9.3 (4.2)

Note

^① Includes terminals.

Ground Fault Relay



9

Ground Fault Relay

Product Description

A Type GFR ground fault protection system, when properly installed on a grounded electrical system, will sense phase-to-ground fault currents. When the level of fault current is in excess of the pre-selected current pickup and time delay settings, the GFR relay will initiate a trip action of a disconnect device, which will open the faulted circuit and clear the fault.

The GFR devices are UL Class 1 devices designed to protect electrical equipment against extensive damage from arcing ground faults.

A basic Type GFR ground fault protection system consists of a ground fault relay, a ground fault current sensor and a disconnect device equipped with a shunt trip device. This disconnect device can be a molded case circuit breaker, a power circuit breaker, a bolted pressure switch or other fusible disconnect device, suitable for application with UL Class 1 Ground Fault Sensing and Relaying equipment.

Contents

Description

<i>Description</i>	<i>Page</i>
Product Selection Guide	V3-T9-158
FP-6000 Feeder Protection	V3-T9-162
FP-5000 Feeder Protection	V3-T9-172
FP-4000 Feeder Protection	V3-T9-180
MP-3000 Motor Protection	V3-T9-188
MP-4000 Motor Protection	V3-T9-198
MD-3000 Motor/Generator Differential Relay	V3-T9-204
Digitrip 3000	V3-T9-207
VR-300 Multifunctional Voltage Relay	V3-T9-217
DP-300 Current Differential Protection Relay	V3-T9-221
EDR-3000 Feeder Protection	V3-T9-226
ETR-4000 Transformer Protection Relay	V3-T9-237
Ground Fault Relay	
Options and Accessories	V3-T9-252
Technical Data and Specifications	V3-T9-253
Universal RTD Module	V3-T9-254
IQ 125 Volt DC Power Supply	V3-T9-258

Standards and Certifications

Eaton's GFR ground fault relays, current sensors, test panels and accessory devices are UL listed by Underwriters Laboratories in accordance with their standard for Ground Fault Sensing and Relaying Equipment, UL 1053, under File No. E48381.

Note: Relays are also listed with CSA under File No. 43357.



Product Selection

Each installation requires:

- One relay unit (select trip ampere as required)
- One current sensor (select configuration required)
- One circuit breaker or disconnect device with shunt trip, or a shunt trip attachment for mounting in existing breaker
- Test panel (optional)

GFR Relay



GFR Relay

GFR Relay Types	Ground Fault Pickup Amperes		
	1–12 Catalog Number ①	5–60 Catalog Number ①	100–1200 Catalog Number ①
For 120 Volt 50/60 Hz Control			
Electrical reset with zone interlocking	GFR12EI	GFR60EI	GFR1200EI
Electrical reset without zone interlocking	GFR12E	GFR60E	GFR1200E
Mechanical reset with zone interlocking	GFR12MI	GFR60MI	GFR1200MI
Mechanical reset without zone interlocking	GFR12M	GFR60M	GFR1200M
For 120 Vdc Control			
Mechanical reset without zone interlocking	—	—	GFR1200MD

Current Sensor

Description—Window Size in Inches (mm)	Catalog Number
Used with Relays Rated 1–12 Amperes	
5.50 (139.7) inside diameter	1283C45G01
Used with Relays Rated 5–60 Amperes	
2.50 (63.5) inside diameter	179C768G01
5.50 (139.7) inside diameter	1256C13G01
7.81 x 11.00 (198.4 x 279.4) rectangular ①	1257C88G04
3.31 x 24.94 (84.1 x 760.5) rectangular ①	1257C92G03
Used with Relays Rated 100–1200 Amperes	
2.50 (63.5) inside diameter	179C768G02
5.50 (139.7) inside diameter	1256C13G02
8.25 (209.6) inside diameter	179C767G02
7.81 x 11.00 (198.4 x 279.4) rectangular ①	1257C88G03
9.94 x 16.94 (252.5 x 430.3) rectangular ①	1257C90G02
9.94 x 23.94 (252.5 x 608.1) rectangular ①	1257C91G02
15.94 x 19.94 (404.9 x 506.4) rectangular ①	1257C89G02
3.31 x 24.94 (84.1 x 633.5) rectangular ①	1257C92G04
6.75 x 29.64 (171.5 x 752.9) rectangular ①	1255C39G03

Note

① Suitable for either surface or semi-flush mounting.

Options and Accessories

Test Panel (120 Vac)

Used to test the ground fault system, to give an indication the relay has tripped the breaker, and to reset the relay after tripping. These functions may be separately mounted pilot devices.

Note: When a mechanically reset relay is used with a test panel, both the relay and test panel must be reset following either a simulated ground fault test or actual ground fault. Not UL listed.

Ground Fault Warning Indicator

This is an accessory item for use with GFR relays with interlocking circuitry. At approximately 30–50% of the relay pickup setting, the indicator switches separate 120 Vac control power to a

lamp or relay (not included) to give an indication of a ground fault. The indicator is rated 110/120 Vac 50/60 Hz for a maximum indicator load of 0.5 amperes.

Indicating Ammeter

The optional indicating ammeter connects to the sensor terminals through a momentary contact pushbutton, and will indicate (in amperes) any ground fault current flowing through the sensor. Kit includes the ammeter and pushbutton.

Not UL listed.

Shunt Trip Attachments

Use 120 Vac shunt trips.

Face Plate

Recommended when these relays are semi-flush mounted, to close the door cutout opening.

Options

Additional optional equipment can be added to the protection system to meet the requirements of the specifying engineer, including:

- Ground fault test panel
- Ground fault warning indicator relay
- Ground fault indicating ammeter

GFR relays are available with zone selective interlocking circuitry to interlock several relays within the same system.

This allows the relay, which detects a ground fault, to instantly clear the fault by tripping the disconnect device. The relay simultaneously sends a signal to relay units “upstream” from the fault to time delay or to block their operation completely. Current sensors in various designs provide a range of “window” sizes to accommodate standard bus and cable arrangements.

Shunt trip attachments may be ordered for field mounting in Eaton’s molded case circuit breakers, or may be ordered factory installed in the breaker.

Optional Test Panel

Control	Test	Catalog Number
120 volt 50/60 Hz	120 volt 50/60 Hz	GFRTP

Ground Fault Warning Indicator

Description	Catalog Number
Manual reset	1234C67G01
Self-resetting	1234C67G02

Ammeter Kit

GFR System Used with	Kit Catalog Number
1–12 amperes	752B820G01
5–60 amperes	752B820G02
100–1200 amperes	752B820G03

Face Plate

Description	Catalog Number
Face plate	752B410G01

Note

① One end removable for installation.

Instruction Leaflet 15321 available as a PDF at www.eaton.com (Go to Advanced Search and enter 15321).

**Technical Data
and Specifications*****GFR Relay***

- Ground fault detection ranges:
 - 1–12 amperes
 - 5–60 amperes
 - 100–1200 amperes
- Output contacts:
 - 240 Vac, 50/60 Hz:
3 amperes
 - 120 Vac, 50/60 Hz:
6 amperes
 - 28 Vdc: 3 amperes
 - 125 Vdc: 0.5 amperes
- Control power requirements:
 - 120V, 50/60 Hz:
0.125 amperes, or
125 Vdc (optional)

Current Sensor

- 600 volt, 50/60 Hz
maximum system voltage

Universal RTD Module



Contents

<i>Description</i>	<i>Page</i>
Product Selection Guide	V3-T9-158
FP-6000 Feeder Protection	V3-T9-162
FP-5000 Feeder Protection	V3-T9-172
FP-4000 Feeder Protection	V3-T9-180
MP-3000 Motor Protection	V3-T9-188
MP-4000 Motor Protection	V3-T9-198
MD-3000 Motor/Generator Differential Relay	V3-T9-204
Digitrip 3000	V3-T9-207
VR-300 Multifunctional Voltage Relay	V3-T9-217
DP-300 Current Differential Protection Relay	V3-T9-221
EDR-3000 Feeder Protection	V3-T9-226
ETR-4000 Transformer Protection Relay	V3-T9-237
Ground Fault Relay	V3-T9-250
Universal RTD Module	
Product Selection	V3-T9-255
Options and Accessories	V3-T9-255
Technical Data and Specifications	V3-T9-255
Dimensions	V3-T9-257
IQ 125 Volt DC Power Supply	V3-T9-258

Universal RTD Module

Product Description

- Electronic Resistance Temperature Detector (RTD) provides motor temperature interface for the MP-3000 Motor Protection Relay
- Monitors up to 11 RTDs consisting of six motor windings, two motor bearings, two load bearings and one auxiliary
- Works with 10 ohm copper, 100 ohm platinum, 100 ohm nickel and 120 ohm nickel type RTDs
- Include fiber optic and electrical communication interfaces to the MP-3000 Motor Protection Relay

Application Description

Eaton's URTD Module is most commonly used to provide motor temperature information to the MP-3000 Motor Protection Relay. The MP-3000 Motor Protection uses this information for monitoring, tripping and alarming. The MP-3000 Intel-I-Trip overload algorithm will adjust its trip characteristics based on the actual motor temperature reported by the URTD Module. This improves the protection by using an actual temperature value instead of the assumed NEMA Standard Ambient Temperature.

The URTD Module may be mounted close to the motor or at the protective relay.

Both electrical and fiber optic interface ports are provided to communicate temperature information to the MP-3000 relay. The electrical interface can transmit information using a three-conductor shielded cable with a maximum cable distance of 500 feet (152m). The fiber optic link has a maximum distance of 400 feet (122m).

The URTD Module may be used with the IQ-1000 and IQ-1000 II motor relays. It may also be applied as a standalone temperature monitoring device communicating, for example, transformer temperature information back to a remote computer or PLC. An optional PONI (Product Operated Network Interface) is required for standalone applications.

Features, Benefits and Functions

- Universal design works with any RTD type, simplifying installation and operation and reducing inventory
- Standalone design permits mounting the module close to the motor, reducing RTD wiring costs
- RTD diagnostics detects faulty RTDs and wiring, reducing unnecessary tripping and alarming

Product Selection

Universal RTD Module



Universal RTD Module

Description

Universal RTD Module

Catalog Number

URTD

Options and Accessories

Additional Related Products from Eaton's Cutler-Hammer Series

The URTD Module must be operated with an MP-3000 Motor Protection Relay, computer or programmable controller. Please refer to the MP-3000 Motor Protection, PONI and PowerNet sections for additional related product information.

Eaton provides fiber optic cables for connecting to the MP-3000 or IQ-1000 II Motor Protection Relays.

Technical Data and Specifications

- Input power requirements: 120 Vac (±15%)
- Frequency: 50/60 Hz
- Power consumption: 6 VA
- Operating temperature: 32°–158°F (0°–70°C)
- Storage temperature: –4°–185°F(–20°–85°C)
- Humidity: 0–95% R.H. noncondensing
- Enclosure: Type 1

Wiring Diagram

RTD Wiring (Three-Lead Type)

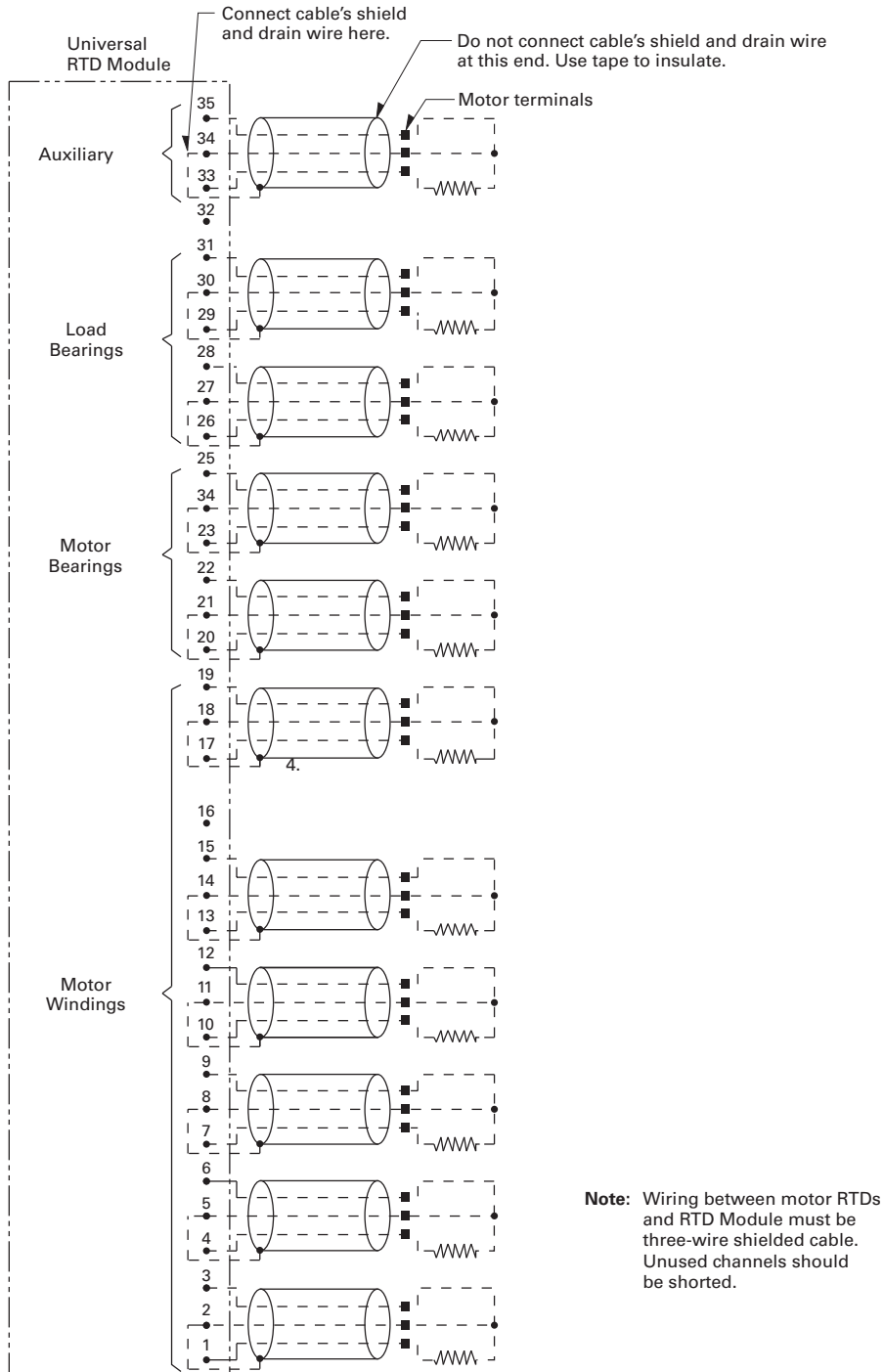

1. Each shielded cable's conductors must be connected on Universal RTD Module as shown.
2. Use of three-lead RTDs is recommended.
3. RTDs must not be grounded at the motor, and no common connections between RTDs should be made at the Universal RTD Module or the motor.
Terminal 16 or 32 should be connected to a suitable earth ground.

Note

Showing a typical three-lead type RTD wiring connection.

Dimensions

Approximate Dimensions in Inches (mm)

Universal URTD Module

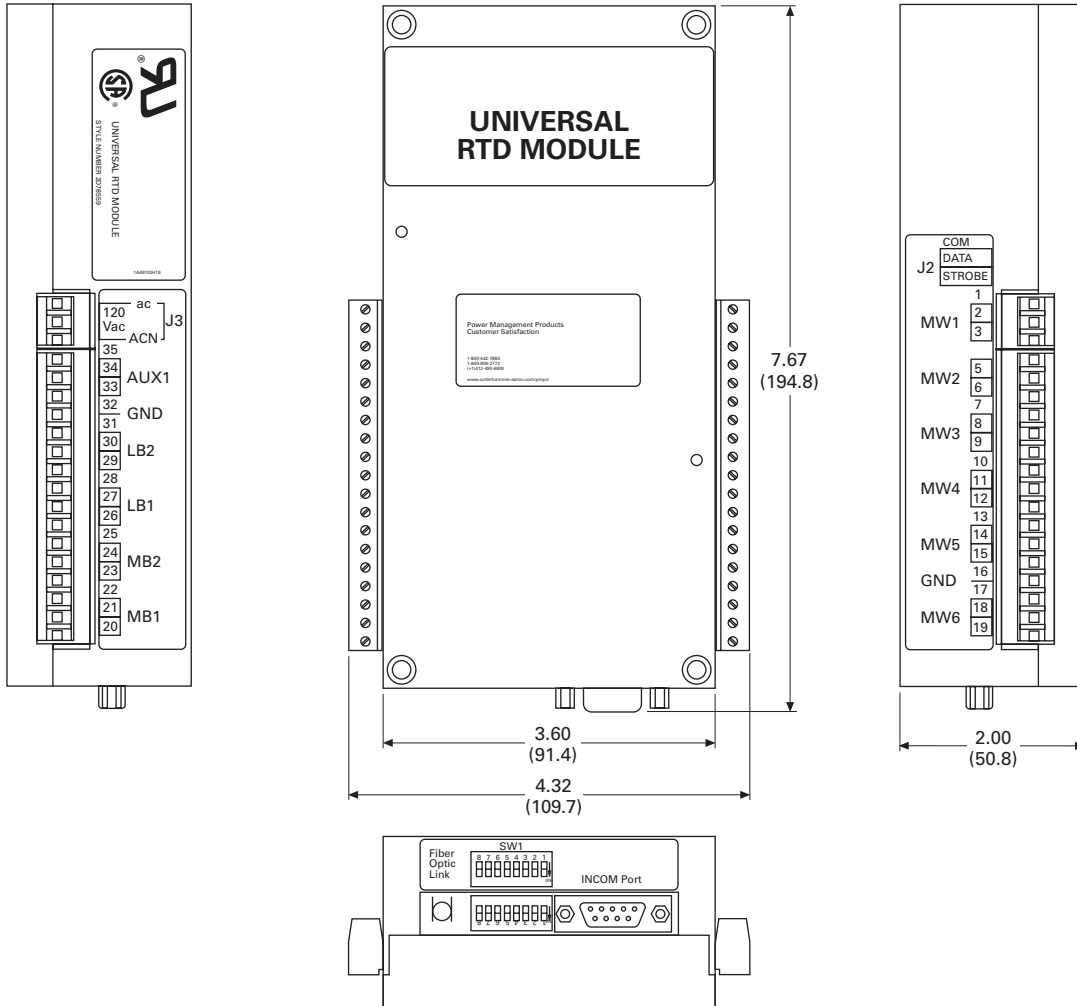

Note

Showing the URTD Module dimensions and terminal designations.

IQ DC Power Supply



9

Contents

<i>Description</i>	<i>Page</i>
Product Selection Guide	V3-T9-158
FP-6000 Feeder Protection	V3-T9-162
FP-5000 Feeder Protection	V3-T9-172
FP-4000 Feeder Protection	V3-T9-180
MP-3000 Motor Protection	V3-T9-188
MP-4000 Motor Protection	V3-T9-198
MD-3000 Motor/Generator Differential Relay	V3-T9-204
Digitrip 3000	V3-T9-207
VR-300 Multifunctional Voltage Relay	V3-T9-217
DP-300 Current Differential Protection Relay	V3-T9-221
EDR-3000 Feeder Protection	V3-T9-226
ETR-4000 Transformer Protection Relay	V3-T9-237
Ground Fault Relay	V3-T9-250
Universal RTD Module	V3-T9-254
IQ 125 Volt DC Power Supply	

IQ 125 Volt DC Power Supply

Product Description

Eaton's IQ DC Power Supply is a DC to AC inverter module intended for use where DC power is available, but some AC is required. The unit will operate Eaton's MP-3000, or other AC powered IQ devices requiring no more than 75 VA of power at any power factor.

The IQ DC power supply is available in two styles, one to be used with the MP-3000 and one for all other products.

Features, Benefits and Functions

- Single, two-wire input—no need to set switches or adjust jumpers
- Four connections—two for DC in, two for AC out
- AC output is isolated from the incoming power
- Built-in protection features protect against short circuits while providing ample power to start loads
- Sinusoidal wave

Product Selection

IQ DC Power Supply	IQ DC Power Supply	Catalog Number
	Description	IQDCPS
	IQ DC power supply module	

Technical Data and Specifications

- Input voltage ranges from 105 Vdc to 140 Vdc
- Rated power output—75 VA at any power factor
- Operating temperature—-4°F to 140°F (-20°C to 60°C)

Power Xpert Gateways



Power Xpert Gateways

Product Description

The Power Xpert Gateway 400/600 is typically installed in an electrical assembly—a motor control center, low/medium voltage switchgear or switchboard to consolidate data available from components such as trip units, meters, motor controllers and protective relays.

Power Xpert Gateways provide a cost-effective method to easily Web-enable Eaton and third-party products.

The Gateway consists of an embedded Web server that allows the user to connect to Eaton products such as breakers, meters and relays found in MCCs, LV and MV Switchgear and switchboards—to name a few—that communicate via Eaton protocols INCOM and QCPort, in addition to third-party products that communicate via Modbus RTU. The Gateway provides the central connection point for the power metering/monitoring/protective devices, allowing their parameters to be monitored via the Web.

Power Xpert Gateways provide data communications to Eaton’s Power Xpert Software to facilitate centralizing and gathering data for long-term data archival, analysis and trending features.

The PXG is compatible with and facilitates integration with many third-party building and factory automation systems via Modbus TCP and Web Services.

The PXG600 allows you to enable pre-selected parameters to be trended for each supported device. Selecting the trend symbol will generate a real-time graph for that parameter and can be viewed for the past 24 hours, seven days, 30 days or all past history.

The PXG600 also offers direct e-mail notifications to up to 10 users. Select from event notifications, data logs, event logs and heartbeat e-mails.

Information is presented in organized, user-friendly Web pages, and includes, but is not limited to, the following:

- Device status
- Comm status

Contents

<i>Description</i>	<i>Page</i>
Power Xpert Gateways	
Product Selection Guide	V3-T9-260
Features	V3-T9-266
Standards and Certifications	V3-T9-267
Product Selection	V3-T9-267
Technical Data and Specifications	V3-T9-268
Dimensions	V3-T9-271
Power Xpert Ethernet Switches	V3-T9-272
Power Xpert Gateway	
Series 1000 Card—Power Distribution Unit	V3-T9-276
Power Xpert Gateway	
Series 2000 Card—Uninterruptible Power Supplies	V3-T9-279
mMINT	V3-T9-282
MINTII RS-232 Converter	V3-T9-284
IPONI	V3-T9-285
DPONI	V3-T9-286
MPONI	V3-T9-287
I/O Devices Digital Input Module (DIM)	V3-T9-288
Addressable Relay II	V3-T9-290
Breaker Interface Module II (BIM II)	V3-T9-293
Sub-Network Master Local Display (SMLD)	V3-T9-297
IMPCABLE	V3-T9-299

- Voltage
- Current
- Power
- Power factor
- Energy
- Power quality
- Temperature
- I/O states

Power Xpert Gateway Screenshots



Home Page



Main Page



Bus Page



Device Page

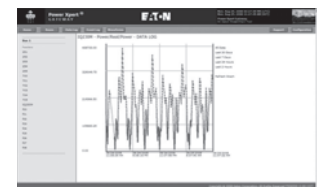

Trending Page (PXG600 Only)

Product Selection Guide

Data Acquisition and Integration Table for Supported Devices

Supported Devices



Device Type	Device Name	PXG 400 and PXG 600					PXG 600 Only			
		HTTP (Web Browser)	Web Services (Power Xpert Software)	Modbus TCP (BMS & SCADA)	Pass-Through INCOM (PowerNet)	Pass-Through QCPort (CHStudio)	SNMP (NMS)	SMTP (E-mail Client)	File Export (Data File Format)	File Export (Waveform File Export)
INCOM										
Drive	Accutrol 400	■	■	■	■	■	■	■	■	
Drive	AF97	■	■	■	■	■	■	■	■	
I/O	Universal RTD	■	■	■	■	■	■	■	■	
I/O	DIM	■	■	■	■	■	■	■	■	
I/O	DIM KYZ	■	■	■	■	■	■	■	■	
Meter	IQ DP-4000 ①	■	■	■	■	■	■	■	■	
Meter	IQ Energy Sentinel	■	■	■	■	■	■	■	■	
Meter	IQ 220/IQ 320	■	■	■	■	■	■	■	■	
Meter	IQ 230/IQ 330	■	■	■	■	■	■	■	■	
Meter	IQ Analyzer (6000/6200) ①	■	■	■	■	■	■	■	■	■
Meter	IQ Analyzer (6400/6600) ①	■	■	■	■	■	■	■	■	■
Meter	IQ Data ①	■	■	■	■	■	■	■	■	
Meter	IQ Data Plus ①	■	■	■	■	■	■	■	■	
Meter	IQ Data Plus II ①	■	■	■	■	■	■	■	■	
Meter	Power Manager	■	■	■	■	■	■	■	■	
Meter	IQ Power Sentinel	■	■	■	■	■	■	■	■	
Meter Point	IQ MES II	■	■	■	■	■	■	■	■	
Protective	Digitrip 3000	■	■	■	■	■	■	■	■	
Protective	Digitrip 3200	■	■	■	■	■	■	■	■	
Protective	FP-5000	■	■	■	■	■	■	■	■	■
Protective	FP-4000	■	■	■	■	■	■	■	■	■
Protective	FP-6000	■	■	■	■	■	■	■	■	■
Protective	MP-3000 ①	■	■	■	■	■	■	■	■	
Protective	MP-4000 ①	■	■	■	■	■	■	■	■	
Protective	Digitrip 520MC	■	■	■	■	■	■	■	■	
Protective	NRX520	■	■	■	■	■	■	■	■	
Protective	IQ 500	■	■	■	■	■	■	■	■	
Protective	MPCV Relay	■	■	■	■	■	■	■	■	
Protective	Digitrip 1150/DT1150V	■	■	■	■	■	■	■	■	■
Protective	Digitrip 810	■	■	■	■	■	■	■	■	
Protective	Digitrip 910	■	■	■	■	■	■	■	■	
Protective	Digitrip MV	■	■	■	■	■	■	■	■	
Protective	Digitrip OPTIM 1050	■	■	■	■	■	■	■	■	■
Protective	Digitrip OPTIM 550	■	■	■	■	■	■	■	■	
Protective	Digitrip OPTIM 750	■	■	■	■	■	■	■	■	
Starter	Advantage ②	■	■	■	■	■	■	■	■	
Starter	Advantage ACM ②	■	■	■	■	■	■	■	■	

Notes

① Required IPONI for connection to the Power Xpert Gateway.

② Required a WPONI for connection to the Power Xpert Gateway.

Information subject to change without notice. Visit www.eaton.com for latest up-to-date details on connectivity.

Data Acquisition and Integration Table for Supported Devices, continued

Supported Devices



Device Type	Device Name	PXG 400 and PXG 600				PXG 600 Only				
		HTTP (Web Browser)	Web Services (Power Xpert Software)	Modbus TCP (BMS & SCADA)	Pass-Through INCOM (PowerNet)	Pass-Through QCPort (CHStudio)	SNMP (NMS)	SMTP (E-mail Client)	File Export (Data File Format)	File Export (Waveform File Export)
INCOM, continued										
Sub-network Master	AEM II ①	■	■	■	■		■	■		
Sub-network Master	BIM II ①	■	■	■	■		■	■		
Sub-network Master	CMU ②	■	■	■	■		■	■		
Sub-network Master	IQ CED II ①	■	■	■	■		■	■		
Sub-network Master	IQ MES II	■	■	■	■	■	■	■		
Transfer Switch	ATC-400 ①	■	■	■	■	■	■	■		
Transfer Switch	ATC-600 ①	■	■	■	■	■	■	■		
Transfer Switch	ATC-800 ①	■	■	■	■	■	■	■		
Modbus										
Drive	MVX9000	■	■	■			■	■	■	
Drive	SVX9000	■	■	■			■	■	■	
Insulation Monitor	InsulGard	■	■	■			■	■	■	
Meter	IQ 130	■	■	■			■	■	■	
Meter	IQ 140	■	■	■			■	■	■	
Meter	IQ 150	■	■	■			■	■	■	
Meter	IQ 230M/IQ 330M	■	■	■			■	■	■	
Meter	IQ 250	■	■	■			■	■	■	
Meter	IQ 260	■	■	■			■	■	■	
Meter	Nexus 1262	■	■	■			■	■	■	
Meter	SQD CM3000 Series	■	■	■			■	■	■	
Meter	SQD CM4000 Series	■	■	■			■	■	■	
Meter	SQD PM710	■	■	■			■	■	■	
Meter	SQD PM850	■	■	■			■	■	■	
Meter	PML 7350	■	■	■			■	■	■	
Meter	PML 7550	■	■	■			■	■	■	
Meter	PML 7650	■	■	■			■	■	■	
Protective	GE 369 Motor Relay	■	■	■			■	■	■	
Protective	GE 469 Motor Relay	■	■	■			■	■	■	
Protective	FP-4000/FP-5000	■	■	■			■	■	■	
Protective	FP-6000	■	■	■			■	■	■	
Overload Relay	C441	■	■	■			■	■	■	
Temp Monitor	Qualitrol 118	■	■	■			■	■	■	
Transformer Differential Relay	ABB TPU 2000	■	■	■			■	■	■	
QCPort										
I/O	D77A-A116	■	■	■		■	■	■	■	
I/O	D77A-A18	■	■	■		■	■	■	■	
I/O	D77A-D116	■	■	■		■	■	■	■	
I/O	D77A-D18	■	■	■		■	■	■	■	
Starter	IT S811 (MV811)	■	■	■		■	■	■	■	
Starter	IT Starter ③	■	■	■		■	■	■	■	
Starter	IT Starter QSNAP ③	■	■	■		■	■	■	■	

Notes

- ① Required IPONI for connection to the Power Xpert Gateway.
- ② Required a WPONI for connection to the Power Xpert Gateway.
- ③ Requires a QSNAP for connection to the Power Xpert Gateway.

Information subject to change without notice. Visit www.eaton.com for latest up-to-date details on connectivity.

The table below represents many of the parameters displayed on the Web page for a given device, however it is not exhaustive. For the complete list of parameters display, per device, refer to the Device Data Map file at HYPERLINK <http://www.eaton.com/powerxpert> www.eaton.com/powerxpert.

Web UI Device Parameters Displayed via Power Xpert Gateway

		IQ Meters																			
		IQ	IQ Data	IQ Data	IQ	IQ	IQ	IQ	IQ	IQ	IQ	IQ	IQ	IQ	IQ	IQ	IQ	IQ	Power	IQ	Power
Units		MES II	Plus II	Plus	Data	Analyzer	Analyzer	DP-	220/	230/	230/	130	140	150	250	260		Sentinel	Sentinel	Manager	
		6200/	6400/	4000	320	330	330M														
Voltage																					
Average	V					■	■														
Voltage (Line-Line)	V		■	■	■	■	■	■	■	■	■	■	■	■	■	■	■	■	■	■	■
Voltage (Line-Neutral)	V	■	■	■	■	■	■	■	■	■	■	■	■	■	■	■	■	■	■	■	■
Current																					
Average	A					■	■														
Phase	A		■	■	■	■	■	■	■	■	■	■	■	■	■	■	■	■	■	■	■
Ground	A					■	■					■									■
Neutral	A					■	■					■									■
Peak	A					■	■		■	■	■	■	■	■	■	■	■	■	■	■	■
Demand	A					■	■		■	■	■	■	■	■	■	■	■	■	■	■	■
Power																					
Apparent	VA					■	■	■	■	■	■			■	■			■	■		■
Reactive	VAR		■	■		■	■	■	■	■	■			■	■	■	■	■	■	■	■
Real	W	■	■	■		■	■	■	■	■	■			■	■	■	■	■	■	■	■
Power Factor																					
Apparent	PF		■	■		■	■	■	■	■	■			■	■	■	■	■	■	■	■
Displacement	PF					■	■	■	■	■	■							■			
Energy																					
Real	Wh		■	■		■	■	■	■	■	■			■	■	■	■	■	■	■	■
Forward	Wh	■				■	■	■	■	■	■			■	■	■	■	■	■	■	■
Reverse	Wh					■	■	■	■	■	■			■	■	■	■	■	■	■	■
Apparent	Vah					■	■	■	■	■	■			■	■	■	■	■	■	■	■
Reactive	VARh					■	■	■	■	■	■			■	■	■	■	■	■	■	■
Leading	VARh					■	■	■	■	■	■			■	■	■	■	■	■	■	■
Lagging	VARh					■	■	■	■	■	■			■	■	■	■	■	■	■	■
Power Quality																					
THD	%						■														
Current THD	%																				■
Voltage THD	%																				■
Frequency	Hz		■	■	■		■	■	■	■	■			■	■	■	■	■	■	■	■
Waveform Capture	N/A					■	■	■													
Temperature																					
Ambient	C																				
Auxiliary	C																				
Load Bearing	C																				
Motor Bearing	C																				
Winding	C																				
Phase (L, C, R)	C																				
Terminal Block	C																				
Input Status																					
Number of Inputs						■	■														
Status/cause of trip																					
Thermal memory																					
Pole temperature																					
Winding temperature																					
Fan status																					
Alarm/trip relay																					

The table below represents many of the parameters displayed on the Web page for a given device, however it is not exhaustive. For the complete list of parameters display, per device, refer to the Device Data Map file at HYPERLINK <http://www.eaton.com/powerxpert> www.eaton.com/powerxpert.

Web UI Device Parameters Displayed via Power Xpert Gateway, continued

	Units	Circuit Breaker Trip Units					Protective Relays												
		Digitrip 1150	Digitrip 520MC	NRX520	Digitrip RMS 910	Digitrip RMS 810	Digitrip OPTIM 1050	Digitrip OPTIM 550	Digitrip OPTIM 750	Digitrip MV	Digitrip 3000	IQ 500	MPVCV Relay	FP-4000	FP-5000	FP-6000	MP-3000	MP-4000	
Voltage																			
Average	V													■	■	■		■	
Voltage (Line-Line)	V	■			■									■	■	■		■	
Voltage (Line-Neutral)	V												■	■	■	■		■	
Current																			
Average	A													■	■	■	■	■	
Phase	A	■	■	■	■	■	■	■	■	■	■	■	■	■	■	■	■	■	
Ground	A	■	■	■	■	■	■	■	■	■	■	■				■	■	■	
Neutral	A	■	■	■	■	■	■	■	■	■	■	■						■	
Peak	A	■						■	■	■	■	■		■	■	■			
Demand	A	■							■	■	■				■	■			
Power																			
Apparent	VA	■													■	■	■	■	
Reactive	VAR	■											■	■	■	■		■	
Real	W	■			■	■	■						■	■	■	■		■	
Power Factor																			
Apparent	PF	■												■	■	■		■	
Displacement	PF													■	■	■		■	
Energy																			
Real	Wh				■	■	■							■	■	■		■	
Forward	Wh	■			■	■	■							■	■	■			
Reverse	Wh	■			■	■	■							■	■	■			
Apparent	Vah	■												■	■	■		■	
Reactive	VARh													■	■	■			
Leading	VARh													■	■	■			
Lagging	VARh													■	■	■			
Power Quality																			
THD	%																■		
Current THD	%													■	■	■			
Voltage THD	%													■	■	■			
Frequency	Hz													■	■	■			
Waveform Capture	N/A	■							■					■	■	■			
Temperature																			
Ambient	C																		
Auxiliary	C																	■	■
Load Bearing	C																	■	■
Motor Bearing	C																	■	■
Winding	C																	■	■
Phase (L, C, R)	C																		
Terminal Block	C																		
Input Status																			
Number of inputs														■	■	■	2	2	2
Status/cause of trip		■	■	■	■	■	■	■	■	■	■	■	■	■	■	■	■	■	■
Thermal memory																			
Pole temperature																			
Winding temperature																			
Fan status																			
Alarm/trip relay																	■		

Web UI Device Parameters Displayed via Power Xpert Gateway, continued

	Units	Insulation Monitor InsulGard	Motor Starters & VFDs Accutrol 400	AF97	Advantage Starters	/T. S811	/T. Starters/ QSNAP	SVX & MVX Drives	Transfer Switches ATC-400	ATC-600	ATC-800
Voltage											
Average	V	■	■					■			
Voltage (Line-Line)	V					■			■	■	■
Voltage (Line-Neutral)	V										
Current											
Average	A	■	■			■	■	■			
Phase	A			■	■	■					
Ground	A										
Neutral	A										
Peak	A										
Demand	A										
Power											
Apparent	VA		■								
Reactive	VAR										
Real	W										
Power Factor											
Apparent	PF										
Displacement	PF										
Energy											
Real	Wh										
Forward	Wh										
Reverse	Wh										
Apparent	Vah										
Reactive	VARh										
Leading	VARh										
Lagging	VARh										
Power Quality											
THD	%										
Current THD	%										
Voltage THD	%										
Frequency	Hz	■	■					■	■	■	■
Waveform Capture	N/A										
Temperature											
Ambient	C	■						■			
Auxiliary	C										
Load Bearing	C										
Motor Bearing	C										
Winding	C										
Phase (L, C, R)	C										
Terminal Block	C										
Input Status											
Number of inputs						■	■	■			
Status/cause of trip						■	■	■			
Thermal memory						■	■	■			
Pole temperature						■	■	■			
Winding temperature											
Fan status											
Alarm/trip relay											

Note

Information subject to change without notice. Visit www.eaton.com for latest up-to-date details on connectivity.

Web UI Device Parameters Displayed via Power Xpert Gateway, continued

	I/O		Third-Party Devices																			
	Units	DIM KYZ	EDR-3000	Digital Input Module	D77A-AI16	D77A-AI8	D77A-DI16	D77A-DI8	Uni-versal RTD	C441 Overload Relay	SQD CM 3000 Series	SQD CM 4000 Series	SQD PM 710	SQD PM 850	PML 7350	PML 7550	PML 7650	GE 369 Motor Relay	GE 469 Motor Relay	ABB TPU 2000	Qualitrol 118	Nexus 1262/1272
Voltage																						
Average	V								■	■	■		■	■	■	■						■
Voltage (Line-Line)	V								■	■	■	■	■	■	■	■						■
Voltage (Line-Neutral)	V									■	■	■	■	■	■	■				■		■
Current																						
Average	A								■	■	■	■		■	■	■	■	■	■			■
Phase	A		■							■	■	■	■	■	■	■	■	■	■	■	■	■
Ground	A								■	■	■							■	■			
Neutral	A									■	■	■										■
Peak	A		■							■		■	■									■
Demand	A		■							■												■
Power																						
Apparent	VA									■	■	■	■	■	■	■	■			■		■
Reactive	VAR									■	■	■	■	■	■	■	■			■		■
Real	W									■	■	■	■	■	■	■	■			■		■
Power Factor																						
Apparent	PF									■	■	■	■	■	■	■	■			■		■
Displacement	PF									■	■	■										
Energy																						
Real	Wh	■								■	■	■	■	■						■		■
Forward	Wh									■	■		■	■	■	■						■
Reverse	Wh									■	■		■	■	■	■						■
Apparent	Vah									■	■	■	■	■	■	■						
Reactive	VARh									■	■	■	■	■								
Leading	VARh									■	■		■	■	■	■						■
Lagging	VARh									■	■		■	■	■	■						■
Power Quality																						
THD	%												■									
Current THD	%																					■
Voltage THD	%																					■
Frequency	Hz								■	■	■	■	■	■	■	■	■					■
Waveform Capture	N/A																					
Temperature																						
Ambient	C																					
Auxiliary	C							■														
Load Bearing	C							■									■	■				
Motor Bearing	C							■									■	■				
Winding	C							■									■	■				
Phase (L, C, R)	C																				■	
Terminal Block	C																					■
Input Status																						
Number of inputs		4	8	16	8	16	8															8
Status/cause of trip								■										■	■			
Thermal memory								■														
Pole temperature																						
Winding temperature																					■	■
Fan status																					■	■
Alarm/trip relay			■																		■	■

Note

Information subject to change without notice. Visit www.eaton.com for latest up-to-date details on connectivity.

Features

The Eaton Power Xpert Gateway 400/600 Includes:

- The Power Xpert Gateway Module
- Mounting provisions and required hardware for panel and DIN rail mounting
- CD-ROM: contains the User Manual, Modbus Register Maps, USB Driver and other associated files

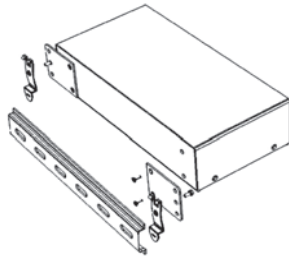

Power Xpert Gateway 400 with DIN Rail Mounting (Brackets Included)

Features of the Power Xpert Gateway 400 vs. 600

Features	PXG 400	PXG 600
Total number of supported devices	64	96
Maximum number of INCOM devices supported	64	64
Protocols supported on downstream devices: INCOM, QCPort and Modbus RTU	Yes	Yes
Number of downstream communication ports	2	3
Number of downstream protocols supported simultaneously	2	3
USB port for configuration	Yes	Yes
Modbus TCP/IP protocols supported	Yes	Yes
SNMP client access	Yes	Yes
INCOM slave action commands supported	Yes	Yes
INCOM date and time settings supported	Yes	Yes
Modbus writes supported	Yes	Yes
Device summary screen per communication port	Yes	Yes
Device waveform access and storage—COMTRADE file format	No	Yes
Set user-defined events	No	Yes
Trend graphs displayed	No	Yes
Data logs—csv file format, downloadable to Excel	No	Yes
Interval logs—csv file format, downloadable to Excel	No	Yes
Event notification via the Web interface	Yes	Yes
Event logs—csv file format, downloadable to Excel	No	Yes
E-mail notification on events and threshold alarms	No	Yes
Secure ethernet communications—SSL encryption	Yes	Yes
Secure communication ports via access control/trusted host list	Yes	Yes
Save and restore configuration file	Yes	Yes

Power Xpert Gateway 400/600

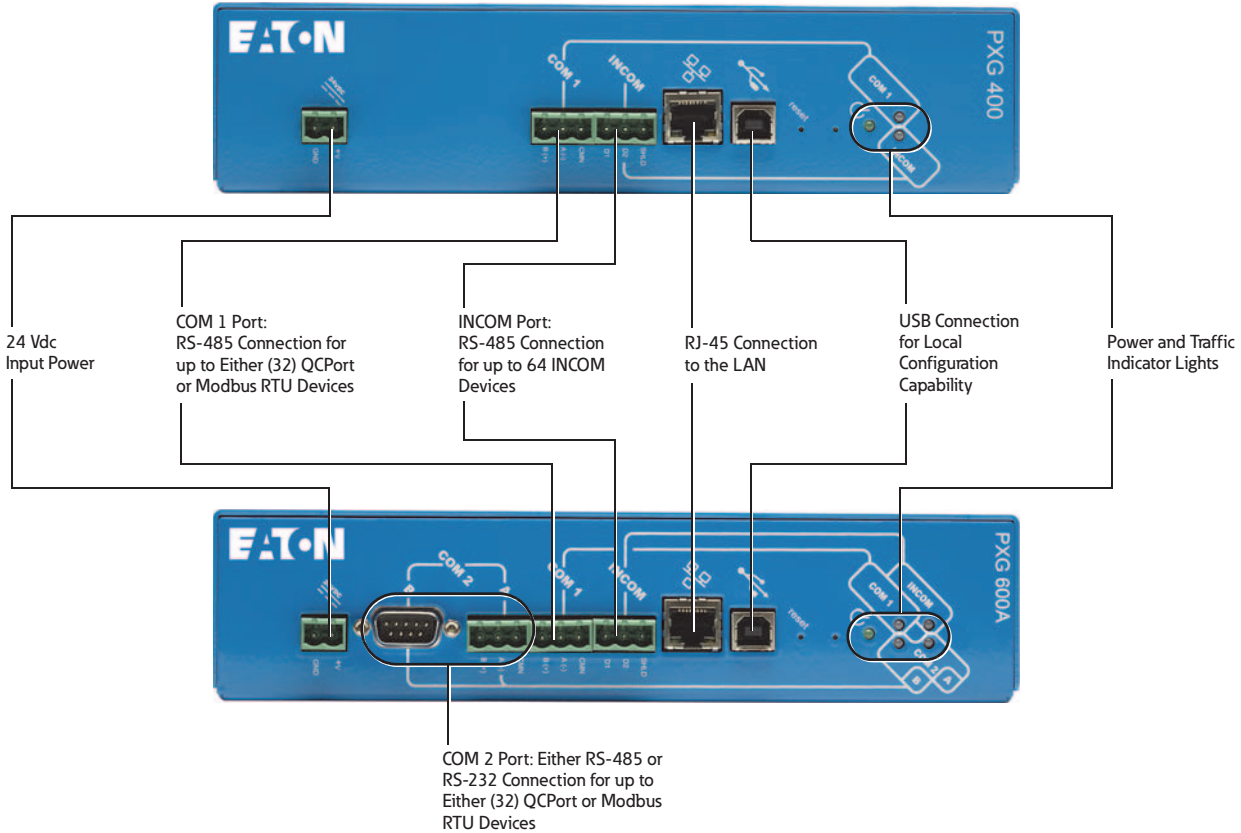



Standards and Certifications

- UL 508, Standard for Programmable Controller Equipment
- FCC, Class A, Part 15, Subpart B, Sections 15.107b & 15.109b
- EN55022: 1994 Class A, Information Technology Equipment
- EN 61000-6-2:2001 Electromagnetic Compatibility (EMC) Party 6-2: Immunity for Industrial Environments



Product Selection

PXG Part Numbers

	Description	Style Number	Catalog Number
	Power Xpert Gateway 400	66D2145G01	PXG400
	Power Xpert Gateway 600	66D2146G01	PXG600
	Power supply—24 Vdc	ELC-PS02	ELC-PS02
	Low profile mounting bracket kit	66B2146G01	PXGACC01

Technical Data and Specifications

Memory

- Flash: 128 MB
- RAM: 64 MB

Communication Ports

- Network port: one 10/100Base-T RJ-45 connector
- Configuration port: one USB port
- Serial ports PXG 400
 - One dedicated RS-485 port for connection to INCOM devices
 - One RS-485 port for connection to either QCPort or Modbus RTU devices
- Serial ports PXG 600
 - One dedicated RS-485 port for connection to INCOM devices
 - One RS-485 port for connection to either QCPort or Modbus RTU devices
 - One RS-485 or RS-232 (software selectable) port for connection to either QCPort or Modbus RTU devices

Network Protocols Supported

- Modbus TCP/IP: Supports data access from Modbus TCP clients
- Web server: Supports data access from Web browsers (HTTP and HTTPS)
- DHCP: Supports automatic IP address assignments, if enabled
- SNMP: Supports common network management tools
- NTP: Supports time synchronization via a network time server for PXG synchronization
- SMTP: Supports mail server for e-mail notification

Serial Protocols Supported

- INCOM
- QCPort
- Modbus RTU

Supported Devices

Refer to www.eaton.com/powerxpert for most current list. Call for information on additional devices.

Web Browsers Recommended

- IE 6.0 or higher
- Mozilla Firefox 2.0 or higher

Number of Devices Supported

- PXG 400
 - 64 total with INCOM port + COM 1 port not to exceed 64. Port limitations are as follows:
 - INCOM port: Up to 64 INCOM devices
 - COM 1 port: Up to 32 QCPort or Modbus RTU devices
- PXG 600
 - 96 total with INCOM port + COM 1 port + COM 2 port not to exceed 96. Port limitations are as follows:
 - INCOM port: Up to 64 INCOM devices
 - COM 1 port: Up to 32 QCPort or Modbus RTU devices
 - COM 2 port: Up to 32 QCPort or Modbus RTU devices

Power Input

- Input voltage, nominal: 24 Vdc; 0.8 A
- Input voltage range: $\pm 20\%$ nominal

Power Consumption

- 8 watts maximum

Operating Temperature

- 32 to 140°F (0 to 60°C)

Ambient Storage Temperature

- -40 to 185°F (-40 to 85°C)

Relative Humidity

- 5 to 95% noncondensing at 50°C

Note: Features and specifications listed in this document are subject to change without notice and represent the maximum capabilities of the product with all options installed. Although every attempt has been made to ensure the accuracy of information contained within, Eaton makes no representation about the completeness, correctness or accuracy and assumes no responsibility for any errors or omissions. Features and functionality may vary depending on selected options.

General Wiring Guidelines—RS-485 Network

When communicating over RS-485 networks to Eaton products, the following General Wiring Guidelines should be used.

Rule 1: Cable Selection—Twisted Shielded Pair (TSP)

Note: Cables specifically designed for RS-485 applications are highly recommended.

The RS-485 bus is a length of Twisted Shielded Pair (TSP) that includes a third conductor (used for the common wire), a braided shield accompanied by a drain wire, and nominal impedance of 120 ohms.

- Belden Wire and Cable Company Part Number 3106A or equivalent

Rule 2: Cable Intermixing

Any cable in the Belden 3106A family can be intermixed with each other in the Modbus network.

Rule 3: System Topology, Size and Capacity

- Strict daisy chain must be adhered to. A strict daisy chain configuration is one where the transmission line connects from one RS-485 receiver to the next. The transmission line appears as one continuous line to the RS-485 driver
- Maximum 32 devices
- Line termination: Maximum cable lengths of 4000 feet (1219m); longer bus lengths will slow the data rate

Rule 4: Cable Splicing

The prime goal is to create a secure electrical connection while minimizing exposure to electrical transients. Ferrules are used to dress cable ends. Most devices have built-in terminal blocks that can be used for splicing. Additionally, terminal blocks should be utilized when splicing elsewhere in the gear or facility to ensure a secure electrical connection.

Rule 5: Cable Shielding

The cable shielding and outer jacket should not be stripped back beyond 1-1/2 inches. Three-pole terminal blocks are used to ensure a continuous metallic shield ground path. To ensure a secure electrical connection when daisy chaining devices that have built-in two-pole terminal blocks, mechanically crimp sleeves onto the two shield path drain wires.

Rule 6: Cable Grounding

Ground the communication network at only one point in the network, preferably by terminating the drain wire to ground at the EOL node (same location as the EOLR). A solid earth ground is accomplished by connecting the shield ground path's drain wire to a #14 AWG or larger multi-stranded wire that has an impedance path of 1 ohm or less to a known earth ground.

Note: The building electrical ground may not be effective since it may travel through many connections and considerable distances before reaching earth ground. In such cases, a new

ground path will be required since the effectiveness of this shield earth ground connection will affect the integrity of data transferred over the cable.

Rule 7: Cable Termination

End of Line Resistors (EOLR) are necessary to maintain signal strength and minimize reflections. EOLR must match the impedance of the TSP. Two EOLR are needed and should be located at both ends of the RS-485 bus. If there is only one device connected to the Modbus master, it is considered the last device in the network and should be terminated with a 120 ohm 1/4 watt terminating resistor.

Rule 8: Device Addressing

- Each device must have a unique slave address
- No two devices on the same RS-485 network can have the same slave address

Ethernet Cable Specifications

For complete specifications, refer to the IEEE 802.3 Ethernet specification.

RS-485 Wiring Guide—Three Terminal Devices

Device Name	A (- Wire)	B (+ Wire)	Common Wire	XCVR Common ①	Data Bias
IQ 230M	12 (MOD2)	11 (MOD1)	10 (INCOM 3)	I 26V	None
IQ 250	(-) Older Models are Marked B (-)	(+) Older Models are Marked A (-) or A(+)	SH	I	None
IQ 260	(-) Older Models are Marked B (-)	(+) Older Models are Marked A (-) or A(+)	SH	I	None
IQ 330M	12 (MOD2)	11 (MOD1)	10 (INCOM 3)	I 26V	None
NETLINK	1 (DATA-)	2 (DATA+)	5 (GND)	E	None
InsulGard ②	B	A	None	Floating	None
Bushing Gard ② (InsulGard G3 ②)	B	A	None	Floating	None
Power Xpert Meter 4000/6000/8000	Data A 750B-S	Data B 750B-S	Shield (COM)	I 300V	750 Ohm Switch Sel
Power Xpert Gateway 400/600	A(-)	B(+)	COM	I	—

Notes

① Transceiver (XCVR) Common Connected to:

- I = Isolated
- NI = Non Isolated
- E = Earth Ground

② Center terminal on InsulGard (marked with Ground symbol) is for shield splicing only and is electrically floating.

INCOM Network

INCOM was specifically designed with the intention of delivering a comprehensive and powerful energy management solution for use in electrical distribution environments while ensuring affordability, flexibility, simplicity and noise immunity. An INCOM network installed per the following rules will allow the user to fully realize all of the above advantages. (Refer to Eaton document TD17513 for specific system layout recommendations and details.)

Rule 1: Cable Selection— Twisted Shielded Pair

Approved cable types:

- Any of the cables in the Belden 9463 family
- Quabbin 6205
- CommScope 9022
- Manhattan Electric M4154
- IMPCABLE—a 600V rated cable custom designed for INCOM— Style # 2A95705G01

Rule 2: Cable Intermixing

Due to impedance differences between IMPCABLE and the Belden 9463 family, the main cable run(s) should be entirely for the 9463 family OR IMPCABLE: do not alternate between these types. The cable used for taps can be different from the main run.

Rule 3: System Topology, Size and Capacity

Supports daisy chain, star and multi-level network segment topologies.

Note: Star Segment Topology is not recommended for new designs.

See **Page V3-T9-271**. Surge protection is required for FSK networks that leave a building at the egress/ingress of the building.

- Supports distances up to 10,000 ft (3048m) per segment when designed within the specifications of this guideline

- Supports up to 1000 devices on a single network segment
- Supports sub-network master devices and associated sub-networks
- Supports 1200 or 9600 baud rate
- Attenuation:
 - Total system capacity: 25 dB
 - Attenuation per device: 0.01 dB
 - Attenuation for approved wire types, see tables below

Cable Attenuation

Cable Type	Attenuation/ 1000 Feet (305m)
IMPCABLE	1.6 dB
Belden 9463 family	2.0 dB

Attenuation at Star

Number of Long Lines	Attenuation
3	3.5 dB
4	6 dB
5	8 dB

- Definitions:
 - **Daisy chain:** point-to-point wiring between devices or clusters of devices
 - **Star:** single point with a number of long lines emanating from it
 - **Long line:** >200-foot (61m) wire run
 - **Simple tap:** <200-foot (61m) connection to cluster of devices

Rule 4: Cable Splicing

The goal is to create a secure electrical connection while minimizing exposure to electrical transients. Ferrules are used to dress cable ends in order to avoid problems associated with frayed and loose wires. Besides facilitating cable installation, subsequent data line troubleshooting and downtime are minimized. Most INCOM devices have built-in three-pole terminal blocks for data lines and shield. For older INCOM devices that have only two terminals, shield continuity

must be ensured by other means. Additional terminal strips should be utilized when splicing elsewhere in the electrical enclosure or facility to ensure secure electrical connections. All devices, End of Line Termination Resistors and Taps should be wired in parallel across the cable.

Rule 5: Cable Shielding

The cable shielding and outer jacket should not be stripped back beyond 1.5 inches (38 mm). Terminal blocks are used at tap points to ensure a continuous metallic shield ground path. To ensure a secure electrical connection when daisy-chaining INCOM devices that have built-in two-pole terminal blocks, use crimp sleeves to join the two shield drain wires. The cable shield ground path for a main network and sub-network must not be joined. Each should have a separate connection to earth ground reference.

Rule 6: Cable Grounding

The shield should be continuous across a network segment and connected to the building's electrical system grounding electrode conductor. The 2005 NEC provides the following guidance on grounding communication cables:

1. When a communication cable enters a building, a primary protector is required and must be grounded as described in Section 800 IV. Specifically, Paragraphs 800.93 and 800.100 define grounding requirements for the primary protector.
2. Grounding systems are generally covered by Section 250 III. The grounding electrode conductor is specifically covered by Paragraphs 250.62, 250.64, 250.66, 250.68 and 250.70.
3. Bonding requirements between communication systems and the power distribution system is specified by Paragraph 250.94.

A solid earth ground is accomplished by connecting the shield ground path's drain wire to a #14 AWG or larger multi-stranded wire that has an impedance path of 1 ohm or less to the building's grounding electrode conductor.

Rule 7: Cable Termination

Each network segment requires a minimum of two End of Line Termination Resistors (EOLTRs). The EOLTRs maintain signal strength and minimize reflections. The EOLTRs should be 1/2 watt 100 ohm non-inductive resistors, such as carbon composition or metal film. Wire-wound resistors are not acceptable. Taps on network segments should not be terminated. Some INCOM devices have the EOLTR permanently installed and must be located at the end of a main run. Other INCOM devices have an EOLTR that can be switched to optionally terminate the network segment at the device. Care must be exercised when installing devices containing termination resistors that the switches are set appropriately. A minimum of two, up to a maximum of five EOLTRs must be installed on each network segment as dictated by network topology.

Rule 8: Device Address

In order to avoid the possibility of devices in a Main Network having the same addresses as those in Subnetworks, set Main Network device addresses at 100 or higher excluding addresses 901 to 908.

Daisy Chain Segment Topology

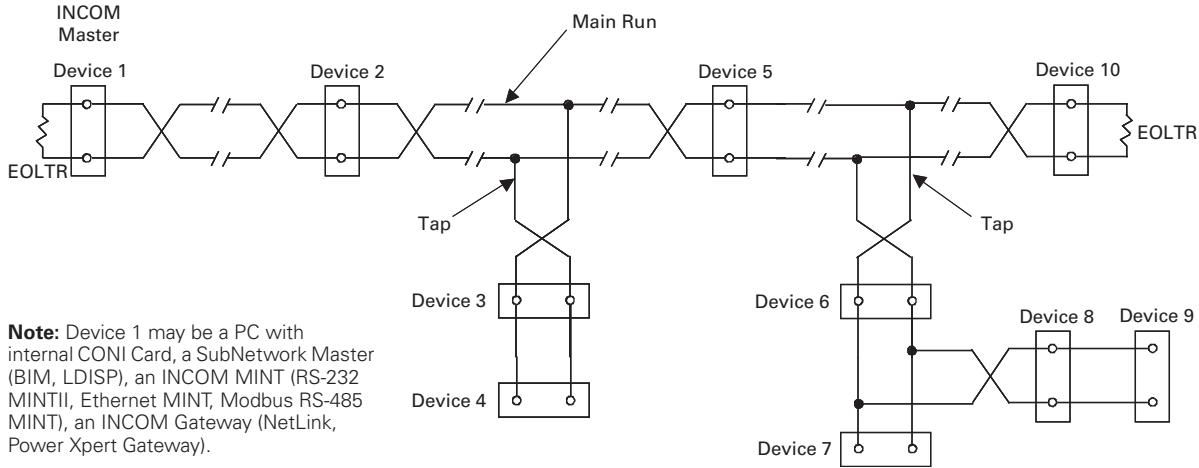

Note: Device 1 may be a PC with internal CONI Card, a SubNetwork Master (BIM, LDISP), an INCOM MINT (RS-232 MINTII, Ethernet MINT, Modbus RS-485 MINT), an INCOM Gateway (NetLink, Power Xpert Gateway).

Dimensions

Approximate Dimensions in Inches (mm)

Power Xpert Gateway 400/600 with Standard Panel Mounting (Brackets Included)

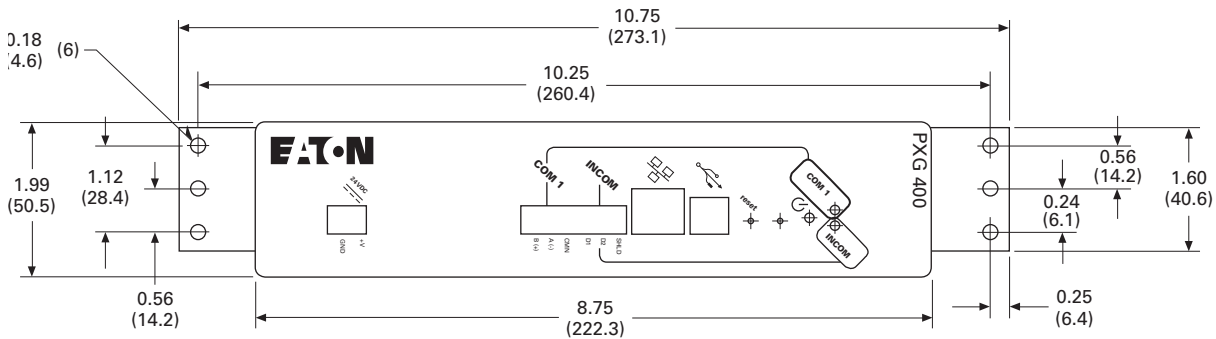

Power Xpert Gateway 400/600 with Low Profile Mounting (Optional Bracket Kit Available)

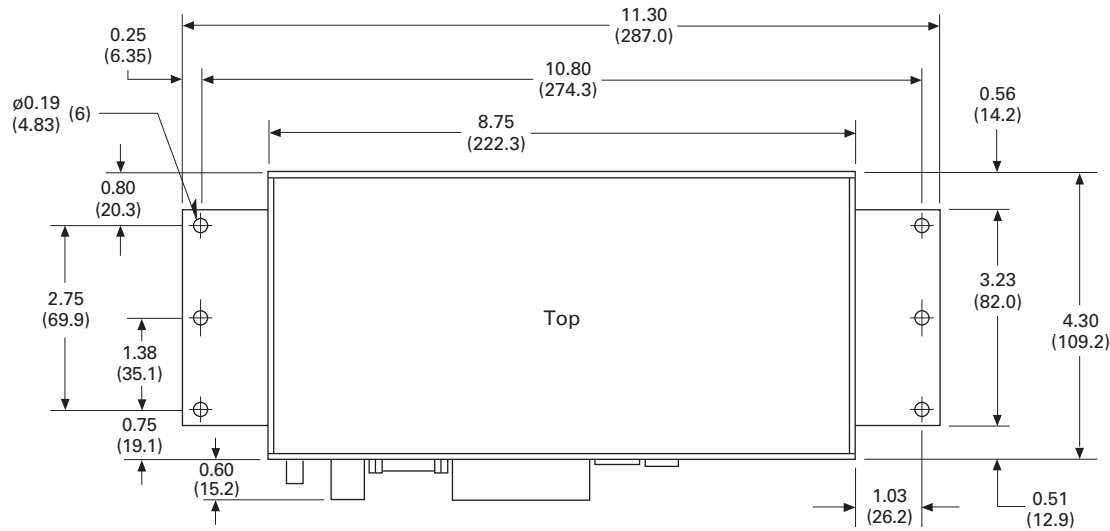

Power Xpert Gateway 400/600

Width	Height	Depth	Shipping Weight Lbs (kg)
8.90 (226.1)	2.10 (53.3)	4.50 (114.3)	1.50 (0.6)

Power Xpert Ethernet Switches



Convenient Network Expansion

Contents

<i>Description</i>	<i>Page</i>
Power Xpert Gateways	V3-T9-259
Power Xpert Ethernet Switches	
Product Selection	V3-T9-273
Accessories	V3-T9-273
Technical Data and Specifications	V3-T9-273
Dimensions	V3-T9-275
Power Xpert Gateway	
Series 1000 Card—Power Distribution Unit	V3-T9-276
Power Xpert Gateway	
Series 2000 Card—Uninterruptible Power Supplies	V3-T9-279
mMINT	V3-T9-282
MINTII RS-232 Converter	V3-T9-284
IPONI	V3-T9-285
DPONI	V3-T9-286
MPONI	V3-T9-287
I/O Devices Digital Input Module (DIM)	V3-T9-288
Addressable Relay II	V3-T9-290
Breaker Interface Module II (BIM II)	V3-T9-293
Sub-Network Master Local Display (SMLD)	V3-T9-297
IMPCABLE	V3-T9-299

Power Xpert Ethernet Switches

Product Description

Eaton’s Power Xpert Ethernet Switches are ideal for extending Ethernet networks via CAT5 wiring or fiber in harsh, industrial environments. Built with high-grade components and constructed using special thermal techniques, PXE Switches can withstand the unpredictable conditions of such environments.

Features

- Simultaneous, full-duplex, high-speed communication on all ports—no network performance bottlenecks
- Hardened for factory floor—ideal for both industrial or data center applications
- Unmanaged, plug-and-play implementation—no software or additional hardware required for configuration
- Seamlessly integrates into Eaton’s Power Xpert Architecture—quality and reliability of Eaton guaranteed
- Mounting options include standalone panel-mounting, DIN rail mounting, or 19-inch standard rack mounting

PXES 6-Port Switch—10/100 Mb with Optional 100 Mb Fiber

This compact switch provides six Ethernet ports, with flexible configurations. The base models have one of three options:

- Two 100 Mb fiber and four 10/100 copper ports
- One fiber and five copper ports
- Six copper ports

PXES 4-Port Switch—10/100 Mb

For smaller applications requiring fewer connection points and no fiber, the 4-port Power Xpert Ethernet Switch is a versatile option. It provides edge access Ethernet ports in a convenient and compact package.

Standards and Certifications

- UL Listed (UL 60950)
- cUL
- CE
- Emissions meet FCC Part 15, Class A



Product Selection

Ethernet Switch



Power Xpert Ethernet Switches

Description	Catalog Number
4-port Ethernet switch—copper only	PXES4P24V
6-port Ethernet switch—copper only	PXES6P24V
6-port Ethernet switch—5 copper/1 fiber (ST connector)	PXES6P24V1ST
6-port Ethernet switch—4 copper/2 fiber (ST connector)	PXES6P24V2ST

Accessories

Ethernet Switch



Power Xpert Ethernet Switches

Description	Catalog Number
Power supply (preferred)—100–240 Vac input DIN rail mount with screw—24 Vdc output terminals	ELC-PS02
Power supply (alternate)—120 Vac input Wall plug-in type with 6 ft cord—12 Vdc output	PXESPS12V
DIN rail mounting bracket	PXESDINRL
19-inch rack mount tray	PXESTRAY

Technical Data and Specifications

Operating Environment

Description	Specifications
Ambient temperature ratings	–25°C to 60°C long-term per independent agency tests (UL), or –40°C to 85°C short-term per IEC type tests
Storage temperature	–40° to 185°F (–40°C to 85°C)
Cold start	to –20°C
Ambient relative humidity	5%–95% (noncondensing)
Altitude	–200 to 50,000 ft (–60 to 15,000m)
MTBF	> 15 years

Network Standards

Description
Ethernet IEEE 802.3, IEEE 802.3u; IEEE 802.1p, 100Base-TX, 10Base-T, 100Base-FX

Power Consumption

Description
7.0 watts typical—9 watts maximum

Packaging

Description	Specifications
Enclosure	Robust sheet metal (steel)
Cooling method	Case used as a heat sink

Mounting

Description	Specifications
Metal panel mounting clips	Included
DIN rail mounting	Optional
19-inch rack mount	Optional

Copper Ethernet Cable Wiring Guidelines

The following information can be used as a guide when designing an Ethernet system using Copper Ethernet Cable.

- Cables should not be routed near equipment that generates strong electric or magnetic fields such as motors, drive controllers, arc welders and conduit
- Ethernet cable insulation has a voltage rating of 300 Vac. Use of barriers, cable trays or high voltage sheathing with STP Ethernet cable may be required in installations with cables carrying voltages greater than 300 Vac. This may also be necessary in order to comply with UL requirements. In installations where the cable cannot be physically separated from the power cables (where a physical barrier is not practical) fiber optic cable should be used
- When crossing power conductors with Ethernet cable, cross at right angles
- Shielded Twisted Pair (STP) Ethernet cable should be specified for use in high noise environments. Shielded shrouded connectors must be used and the shield must be connected at both ends of the wire. The mating plug must have a shielded shroud that is terminated to ground at both ends. Where there is a possibility of a difference in ground potential (common mode) voltages between the two terminated ends, fiber optic cable is recommended
- When using conduit or a metal cable tray, each section of the conduit or tray must be bonded to each adjacent section and the conduit or tray needs to be bonded to earth ground. Do not allow the shields to touch the conduit or metal tray at any point
- Only shielded (STP) Ethernet cables should be placed into metal conduit. Some UTP cables may not function properly when installed in conduit, as the metal conduit can affect the electrical properties of an unshielded cable. Consult the cable manufacturer when installing UTP cables in conduit
- As a general rule for noise protection, Ethernet Cable should maintain a minimum distance of 3 inches (8 cm) from electric power conductors for up to 100 volts and 1 inch (3 cm) for each additional 100 volts up to 400 volts. STP cable is recommended
- For Ethernet cable run within conduit, but near conductors with potentially noisy power conductors carrying currents of greater than 20A or voltages greater than 400V, maintain the following distances. STP cable is required.
 - Conductors of less than 20A = 3 inches
 - Conductors of 20A or more and up to 100 kVA = 6 inches
 - Conductors greater than 100 kVA = 12 inches
- For Ethernet cable run near conductors with potentially noisy power conductors carrying currents of greater than 20A or voltages greater than 400V, maintain the following distances. STP cable is recommended
 - Conductors of less than 20A = 6 inches
 - Conductors of 20A or more and up to 100 kVA = 12 inches
 - Conductors greater than 100 kVA = 24 inches
- Route Ethernet cable at least 5 feet (1.5m) from sources of rf/microwave radiation. STP cable is required
- Do not cascade more than four Ethernet repeaters (router, switch or hub) within a network segment
- Environmentally sealed connectors should be specified for cables used in outdoor installations
- Avoid pinching the cable when using cable ties
- Total distance between an Ethernet Transmitter and Receiver at the end points of the network should not exceed 328 feet (100m)
- Total distance from a patch panel to a wall jack (using solid cable) shall not exceed 295 feet (90m). Splices are not permitted
- Patch cords used as cross-connect jumpers in a patch panel should not exceed 20 feet (6m)
- Patch cords from a wall jack to the work area PC (or device) shall not exceed 16 feet (5m)
- Ethernet cable used in harsh environments must be selected to withstand the following conditions: vibration, air born contaminants, chemicals, temperature, electromagnetic interference, combustible atmospheres and local regulatory standards such as UL and NEMA
- Ethernet connectors used in harsh environments must be robust enough to withstand vibration, multiple connection cycles, temperature changes, and provide a proper seal to protect against moisture, dust/dirt and chemical attack
- Different cable media support different bandwidth capabilities. When installing cable in a network, care should be taken to install the cable that will fill current network loading requirements and future expansion needs. In general, fiber optic cable can support the greatest bandwidth (upward of 25,000 gigabits) and UTP has the lowest. CAT5e cabling is designed to operate at bit rates up to 1000 Mb and CAT6 cable up to 2000 Mb
- Operating your cable at maximum speed reduces the distance between network segments. Check with your cable supplier for specifications regarding segment distance vs. speed
- Cable with 5% impedance mismatch or return loss of 27 to 32 dB is recommended. Ethernet cable impedance can vary by as much as 15% (85 to 115 ohms). Average Ethernet cable with 15% impedance variation can have up to 10 dB additional return loss. This discontinuity is referred to as return loss, since it causes some of the signal to be reflected back down the cable instead of propagating forward. It is measured in decibels or ratio of transmitted versus reflected signal

Fiber Optic Technology

The use of fiber optics in telecommunications and wide area networking has been common for many years, but more recently fiber optics have become increasingly prevalent in industrial data communications systems as well. High data rate capabilities, noise rejection and electrical isolation are just a few of the important characteristics that make fiber optic technology ideal for use in industrial and commercial systems.

Although often used for point-to-point connections, fiber optic links are being used to extend the distance limitations of RS-232, RS-422/485 and Ethernet systems while ensuring high data rates and minimizing electrical interference.

Conventional electrical data signals are converted into a modulated light beam, introduced into the fiber and transported via a very small diameter glass or plastic fiber to a receiver that converts the light back into electrical signals.

Optical fibers allow data signals to propagate through them by ensuring that the light signal enters the fiber at an angle greater than the critical angle of the interface between two types of glass. Optical fiber is actually made

up of three parts. The center core is composed of very pure glass. Core dimensions are usually in the range of 50 to 125 um for multi-mode cables and 8-9 um for single-mode cables. The surrounding glass, called cladding, is a slightly less pure glass. The diameter of the core and cladding together is in the range of 125 to 440 um.

Surrounding the cladding is a protective layer of flexible silicone called the sheath.

Fiber Optic Cable Wiring Guidelines

The following information can be used as a guide when designing an Ethernet system using Fiber Optic Ethernet Cable:

- Select a fiber cable that is suited for the application, e.g., outdoor, aerial, duct, intra-building, risers, general building and plenum applications
- Fiber optic cable is useful in applications where the environment is combustible, electrically noisy, the cable must be bundles with high voltage wires or where common mode voltages may exist between the earth ground points of the terminating connectors

- Fiber optic cable is available in various operating temperature ranges. Care should be taken to match the temperature rating of the fiber to the environment it will be exposed to. The temperature specification for fiber may be narrower than copper cable. Consult the cable manufacturer for temperature specifications of your cable type
- Sealed fiber connectors are available for use in harsh environments to prevent contamination from entering the connector and fiber. The type of seal required will be application dependant and can vary from dust- and moisture-proof to water-tight
- Mixing fiber cable types is not permitted. The same core dimensions and mode must be used within cable segments
- Care should be taken when purchasing connectors to include strain relief, which reduces mechanical strain (vibration) within the cable, as well as the connector. Strain relief also provides support to the cable to ensure proper bend radius at the connector
- Single-Mode Fiber is used for long distance transmission of up to 120 km. Distance may vary depending on speed and type of converter used
- Multi-Mode Graded-Index Fiber Cable is used for communication over shorter distances of up to 2 km
- Fiber cable is composed of glass and is not well suited for applications requiring tight bend radiuses. Cable radius dimensions vary per manufacturer. If the manufacturer does not provide a bend radius, a typical rule of thumb is a radius not less than 15x the cable diameter
- Fiber cable to connector terminations can be performed in the field using special equipment. This method is not recommended
 - Tier One testing is recommended when diagnosing system irregularities and should be performed in all new installations
 - Tier Two testing is recommended to certify that a system complies with standards set forth by the owner/installer

Dimensions

Packaging

Description	Specifications
Dimensions of PXES4P series	3.5 in H x 3.0 in W x 1.0 in D (8.9 cm x 7.6 cm x 2.5 cm)
Weight of PXES4P series	8.6 oz. (243g)
Dimensions of PXES6P series	3.6 in H x 3.0 in W x 1.7 in D (9.2 cm x 7.6 cm x 4.3 cm)
Weight of PXES6P series	13 oz. (370g)

Power Xpert Gateway Series 1000 Card

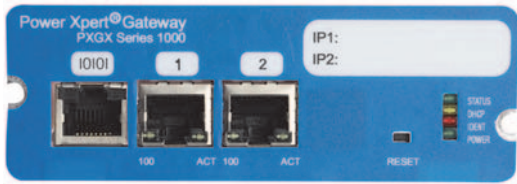

Contents

<i>Description</i>	<i>Page</i>
Power Xpert Gateways	V3-T9-259
Power Xpert Ethernet Switches	V3-T9-272
Power Xpert Gateway Series 1000 Card—Power Distribution Unit	
Features	V3-T9-277
Product Selection	V3-T9-278
Technical Data and Specifications	V3-T9-278
Dimensions	V3-T9-278
Power Xpert Gateway Series 2000 Card—Uninterruptible Power Supplies	
mMINT	V3-T9-282
MINTII RS-232 Converter	V3-T9-284
IPONI	V3-T9-285
DPONI	V3-T9-286
MPONI	V3-T9-287
I/O Devices Digital Input Module (DIM)	V3-T9-288
Addressable Relay II	V3-T9-290
Breaker Interface Module II (BIM II)	V3-T9-293
Sub-Network Master Local Display (SMLD)	V3-T9-297
IMPCABLE	V3-T9-299

Power Xpert Gateway Series 1000 Card—Power Distribution Unit

Product Description

The Power Xpert Gateway Series 1000 Card (PXGX 1000) provides Web-enabled, real-time monitoring of Powerware Power Distribution Units (PDUs), Rack Power Modules (RPM) and Powerware Remote Power Panels (RPPs) through standard on-board Web pages, Power Xpert Software or third-party software.

An integral part of the Power Xpert Architecture, which provides end-to-end PowerChain solutions, the PXGX 1000 provides a central point to connect distribution products to an Ethernet network.

Information is presented in organized, user-friendly Web pages and include the following:

- PDU system identification
- Graphic panel layouts
- Voltage
- Current
- Frequency
- Energy
- Power
- THD (current and voltage)

Features

- Web-enabled monitoring of power quality data down to the branch circuit level—Data can be viewed from any location with a Web browser
- Configure and edit the EMS remotely via the Web interface—supports remote configuration, including naming, alarm and warning set points and percentages
- Data, interval and event logging with time stamp—accurate logging for power quality analysis
- Modbus TCP/IP and SNMP Support—open communication protocol facilitates integration with standard building management systems and network management systems
- Customized e-mail messaging for events notification, including data and event logs and periodic “heartbeat” e-mails—direct alarm and event notification to the appropriate person(s) in the organization
- Easy integration into existing Ethernet infrastructure—minimize installation cost
- Securely access and view information—password authentication is required at two levels. The card also supports secure Web-based communication via SSL
- Generate Modbus Register Maps on the fly—all of the data specific to the system is immediately available and can be generated with one click of the mouse
- Save and Restore settings—configuring a large PDU with EMS can take time. Once the effort is complete, the configuration can be saved for later use. It also allows the user to duplicate panel identical configurations in minimal time
- Supports the Environmental Monitoring Probe—temperature, humidity and contact status can be viewed through the Web page

Standards and Certifications

- FCC Part 15, Class A
- CISPR 22, Class A
- ROHS Compliant
- Telecom conducted via EU Standard
 - EN 55022:1988+A1:2000+A2:2003, Class A
 - EN55022:1988+A1:2000+A2:2003



PDU or RPP System Summary Page

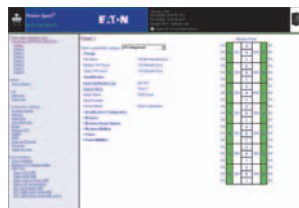

PDU or RPP Panel Page



RPM Panel Page

Product Selection

Power Xpert Gateway Series 1000 Card



Ordering Information

Description	Style Number	Catalog Number
Power Xpert Gateway Series 1000 Card for use with Eaton PDUs, RPPs, RPMs, PDRs and EMS-UGK	103005741-5591	PXGX1000

Technical Data and Specifications

The Power Xpert Gateway Series 1000 Card Kit Includes

- Power Xpert Gateway Series 1000 Card
- Ethernet cable
- Local configuration cable
- Quick start guide

Devices Supported

- Powerware Power Distribution Units with X-Slot® compatibility
- Powerware Remote Power Panels with X-Slot compatibility
- Powerware Rack Power Modules with X-Slot compatibility

Communication Ports

- Ethernet ports: Two independent RJ-45 ports: supports 10/100Base-T for redundant network configurations
- Serial ports: One RJ-45 console port: supports local configuration and optional connection to an Environmental Monitoring Probe (EMP)

Communication Protocols Supported

- Web server: supports data access from Web browsers (HTTP and HTTPS)
- Modbus TCP/IP: supports data access from Modbus TCP clients
- SNMP: supports common network management tools
- SMTP: supports e-mail notification
- NTP: supports time synchronization via an NTP server for card and PDU synchronization
- DHCP: supports automatic IP address assignments, if enabled

Supported MIBs

- Eaton PDU MIB
- Eaton EMP MIB
- Eaton alarms and traps MIB
- RFC 4133 Entity MIB
- RFC 4268 Entity State MIB
- RFC 4268 Entity State MIB Part II
- RFC 1213 MIB II

Web Browsers Supported

- IE
- Mozilla Firefox

Environmental Specifications

- Ambient operating: 0 to +40°C (32 to 104°F)
- Relative humidity: 10 to 80%, noncondensing
- Altitude: 10,000 ft
- Enclosure rating: indoor use only

Mounting Configuration

- X-Slot form factor fits directly into PDU/RPP/RPM chassis

Power Supply

- Nominal input voltage: 12 Vdc, unregulated (provided by PDU/RPP)
- Input voltage range: 8–25 Vdc, unregulated

Power Consumption

2.0 watts

Note: Features and specifications listed in this document are subject to change without notice and represent the maximum capabilities of the software and products with all options installed. This is not a complete feature list. Features and functionality may vary depending on selected options.

Dimensions

Approximate Dimensions in Inches (mm)

Physical Characteristics

Height	Width	Depth	Weight Lbs (kg)
1.50 (39.0)	4.70 (120.0)	4.50 (114.0)	0.44 (0.2)

Power Xpert Gateway Series 2000 Card

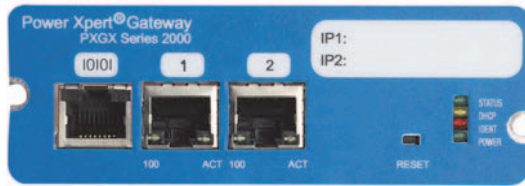

Contents

<i>Description</i>	<i>Page</i>
Power Xpert Gateways	V3-T9-259
Power Xpert Ethernet Switches	V3-T9-272
Power Xpert Gateway Series 1000 Card—Power Distribution Unit	V3-T9-276
Power Xpert Gateway Series 2000 Card—Uninterruptible Power Supplies Features	V3-T9-280
Standards and Certifications	V3-T9-280
Product Selection	V3-T9-281
Technical Data and Specifications	V3-T9-281
Dimensions	V3-T9-281
mMINT	V3-T9-282
MINTII RS-232 Converter	V3-T9-284
IPONI	V3-T9-285
DPONI	V3-T9-286
MPONI	V3-T9-287
I/O Devices Digital Input Module (DIM)	V3-T9-288
Addressable Relay II.	V3-T9-290
Breaker Interface Module II (BIM II)	V3-T9-293
Sub-Network Master Local Display (SMLD)	V3-T9-297
IMPCABLE	V3-T9-299

Power Xpert Gateway Series 2000 Card—Uninterruptible Power Supplies

Product Description

The Power Xpert Gateway Series 2000 Card (PXGX 2000) provides Web-enabled, real-time monitoring of Powerware Uninterruptible Power Supplies (UPS) through standard on-board Web pages, Power Xpert Software or third-party software.

An integral part of the Power Xpert Architecture, which provides end-to-end PowerChain solutions, the PXGX 2000 provides a central point to connect distribution products to an Ethernet network.

Information is presented in organized, user-friendly Web pages and include the following:

- UPS system identification
- Voltage
- Current
- Frequency
- Energy
- Output Power
- Power—full load %
- Battery information
 - History and maintenance
 - Run time remaining
 - Voltage
 - % battery left

Features

- Web-enabled monitoring of power quality data—data can be viewed from any location with a Web browser
- Data, event and system logging with time stamp—accurate logging for power quality analysis
- Modbus TCP/IP and SNMP Support—open communication protocol facilitates integration with standard building management systems and network management systems
- Intelligent e-mail communications—two options for alarm and event e-mail notification, individual e-mails for each alarm or event, or collective notification, providing the same information with a drastically reduced number of e-mails
- Easy integration into existing Ethernet infrastructure—minimize installation cost
- Securely access and view information—password authentication is required at two levels. The card also supports secure Web-based communication via SSL
- Generate Modbus Register Maps on the fly—all of the data specific to the UPS is immediately available and can be generated with one click of the mouse
- Save and Restore settings—once the configuration effort is complete, it can be saved for later use
- Supports the Environmental Monitoring Probe—temperature, humidity and contact status can be viewed through the Web page
- Two independent, redundant Ethernet ports—designed to support high reliability systems



UPS Summary Page



Alarm Summary Page



NetWatch Support Page

Standards and Certifications

- FCC Part 15, Class A
- CISPR 22, Class A
- ROHS Compliant
- Telecom conducted via EU Standard
 - EN 55022:1988+A1:2000+A2:2003, Class A/EN55022:1988+A1:2000+A2:2003



Product Selection

Power Xpert Gateway Series 2000 Card



Ordering Information

Description	Style Number	Catalog Number
Power Xpert Gateway Series 2000 Card for use with Powerware UPSs	103005868-5591	PXGX 2000

Technical Data and Specifications

The Power Xpert Gateway Series 2000 Card Kit Includes

- Power Xpert Gateway Series 2000 Card
- Ethernet cable
- Local configuration cable
- Quick start guide

Devices Supported

- Powerware uninterruptible power supplies with X-Slot compatibility; these include the Powerware 5115 RM, 5125, 9125, 9140, 9155, 9315, 9355, 9330, 9390, 9395, BladeUPS x

Communication Ports

- Ethernet ports: two independent RJ-45 ports: supports 10/100Base-T for redundant network configurations
- Serial ports: one RJ-45 console port supports local configuration and optional connection to an Environmental Monitoring Probe (EMP)

Communication Protocols Supported

- Web server: supports data access from Web browsers (HTTP and HTTPS)
- Modbus TCP/IP: supports data access from Modbus TCP clients
- SNMP: supports common network management tools
- SMTP: supports e-mail notification
- NTP: supports time synchronization via an NTP server for card and UPS synchronization
- DHCP: supports automatic IP address assignments, if enabled

Supported MIBs

- Eaton Power MIB
- RFC 1628 UPS MIB
- Eaton EMP MIB
- Eaton alarms and traps MIB
- RFC 4133 Entity MIB
- RFC 4268 Entity State MIB; RFC 4268 Entity State MIB Part 2
- RFC 1213 MIB II

Web Browsers Supported

- IE
- Mozilla Firefox

Environmental Specifications

- Ambient operating: 0 to +40°C (32 to 104°F)
- Relative humidity: 10 to 80%, noncondensing
- Altitude: 10,000 ft
- Enclosure rating: indoor use only

Mounting Configuration

- X-Slot form factor fits directly into UPS chassis

Power Supply

- Nominal input voltage: 12 Vdc, unregulated (provided by UPS)
- Input voltage range: 8–25 Vdc, unregulated

Power Consumption

- 2.0 watts

Dimensions

Approximate Dimensions in Inches (mm)

Physical Characteristics

Height	Width	Depth	Weight Lbs (kg)
1.50 (39.0)	4.70 (120.0)	4.50 (114.0)	0.44 (0.2)

mMINT Module



Contents

<i>Description</i>	<i>Page</i>
Power Xpert Gateways	V3-T9-259
Power Xpert Ethernet Switches	V3-T9-272
Power Xpert Gateway	
Series 1000 Card—Power Distribution Unit	V3-T9-276
Power Xpert Gateway	
Series 2000 Card—Uninterruptible Power Supplies	V3-T9-279
mMINT	
Technical Data and Specifications	V3-T9-283
MINTII RS-232 Converter	V3-T9-284
IPONI	V3-T9-285
DPONI	V3-T9-286
MPONI	V3-T9-287
I/O Devices Digital Input Module (DIM)	V3-T9-288
Addressable Relay II	V3-T9-290
Breaker Interface Module II (BIM II)	V3-T9-293
Sub-Network Master Local Display (SMLD)	V3-T9-297
IMPCABLE	V3-T9-299

mMINT

Product Description

The mMINT (Modbus Master INCOM Network Translator) Module is an Eaton accessory product that provides communication between a Modbus RTU network and an INCOM (INdustrial COMmunications) network (see **Page V3-T9-283**). This module is transparent to the Modbus network. It communicates to a master on the Modbus network using the Modbus RTU (Remote Terminal Unit) protocol. It communicates to slave devices on the INCOM network using the IMPACC (Integrated Monitoring, Protection, And Control Communication) protocol.

Features

The mMINT module is a slave device on the Modbus network and as such requires a master that will exchange register objects with the mMINT module.

- Handles generic pass-through commands (Modbus/INCOM/Modbus)
- Capable of passing Modbus register objects from Eaton's existing products and newer PnP (Plug-n-Play) products to a Modbus RTU master
- Data in IEEE Floating Point format and fixed point
- Modbus RTU communications data transfer rates of 1200, 9600 or 19,200 baud with one start bit, eight data bits, no parity, and either one or two stop bits

- Up to 32 products connected to INCOM network port (246 unique addresses maximum)
- Flashing Status LED to indicate an active module
- LED indicators for INCOM transmit and receive communications exchanges
- LED indicators for Modbus RS-485 transmit and receive communications exchanges
- Input power for the module from either 120 Vac or 24 to 125 Vdc
- DIN rail mount package
- 0°C to 60°C ambient operation

Standards and Certifications

- UL
- CSA
- CE mark



Product Selection

The catalog number of this product is mMINT.

Technical Data and Specifications

Module Mounting

When mounting the mMINT, verify that an 11 mm H x 28 mm W DIN rail is used and that it is within an enclosed space.

Simplified Wiring Rules

INCOM Network

The following simplified rules apply to a given system consisting of a single daisy-chained main cable link between master and slave devices (see below). For more complex considerations including star configurations, please refer to the IMPACC wiring specification T.D. 17513.

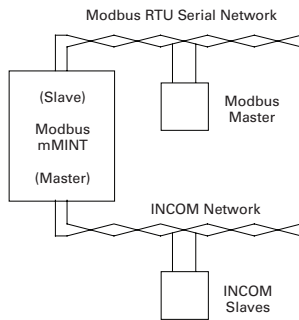

mMINT in a Communications Network

- Recommended INCOM cable styles are Belden 9463 or C-H style 2A957805G01
- The maximum system capacity is 10,000 feet of communications cable and 32 slave devices on the INCOM network under the mMINT
- Non-terminated taps, up to 200 feet in length, off the main link are permitted, but add to the total cable length
- Make sure that there is twisted-pair wire that is recommended for IMPACC network use. Use shielded twisted-pair wire to connect each slave to the INCOM network, daisy-chain style. The polarity of the twisted pair is not important

Modbus RS-485 Network

The following simplified rules apply to a given system consisting of a cable link between master and slave devices (see below). For more complex configurations, please refer to standard Modbus RTU wiring specification rules for the RS-485 network.

- The recommended Modbus cable has twisted-pair wires (24 AWG stranded 7x32 conductors with PVC insulation) having an aluminum/mylar foil shield with drain wire
- The maximum system capacity is 4000 feet of communications cable and 247 devices on the Modbus RTU network
- Make sure that there is twisted-pair wire that is recommended for Modbus RTU network use. Use shielded twisted-pair wire to connect each slave to the Modbus RTU network, daisy-chain style. The polarity of the twisted pair is critically important

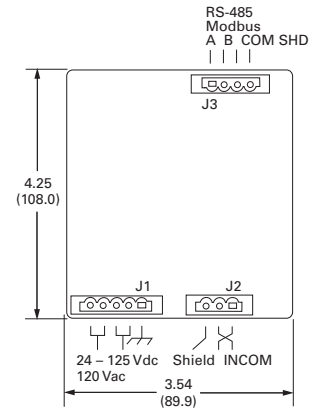

mMINT Module Dimensions

Burden

- 24 Vac/dc 3 VA

Communications Speed

- INCOM: 1200, 9600 baud
- N2 Bus: 9600 baud

Note: Contact Eaton for availability and support for the N2 Gateway.

MINTII RS-232 Converter



Contents

<i>Description</i>	<i>Page</i>
Power Xpert Gateways	V3-T9-259
Power Xpert Ethernet Switches	V3-T9-272
Power Xpert Gateway	
Series 1000 Card—Power Distribution Unit	V3-T9-276
Power Xpert Gateway	
Series 2000 Card—Uninterruptible Power Supplies	
mMINT	V3-T9-279
MINTII RS-232 Converter	
IPONI	V3-T9-285
DPONI	V3-T9-286
MPONI	V3-T9-287
I/O Devices Digital Input Module (DIM)	V3-T9-288
Addressable Relay II	V3-T9-290
Breaker Interface Module II (BIM II)	V3-T9-293
Sub-Network Master Local Display (SMLD)	V3-T9-297
IMPCABLE	V3-T9-299

MINTII RS-232 Converter

Product Description

Converts a network of Power Management Software devices to ASCII RS-232 format for access through a serial port of a personal computer, laptop, or Programmable Logic Controller.

Displayed Parameters

- Eaton's MINTII provides access to all parameters monitored over the Power Management Software network
- Supports INCOM networks up to 8500 feet (2590m) in distance and device counts up to 1000

Application Description

The Master INCOM Network Translator II (MINTII) converts the twisted shielded pair network of INCOM devices to an RS-232 signal. This signal can be accessed by PLCs, computer serial ports, building management system serial interface cards. The MINTII is also often applied as an interface to standard line drivers and converters to allow communication through dedicated telephone lines, dial-up modems, fiber-optic line drivers, radio frequency or wireless modems.

Product Selection

MINTII RS-232 Converter

<i>Description</i>	<i>Catalog Number</i>
Master INCOM Network Translator II	MINTII

Technical Data and Specifications

Temperature

- 0°C to 60°C

Humidity

- 0% to 95%

Power

- 120V

Speed

- 1200, 2400 and 9600 baud (INCOM), 19.2K baud (RS-232)

Communications

- INCOM, RS-232

Dimensions

- Suitable for panel mounting or desktop use
- 120 Vac power cord included for plug-in to standard duplex receptacle
- Height: 2.25 inches (57.2 mm)
- Width: 11.5 inches (292.1 mm)
- Depth: 4.25 inches (108.0 mm)

IPONI Communication Module

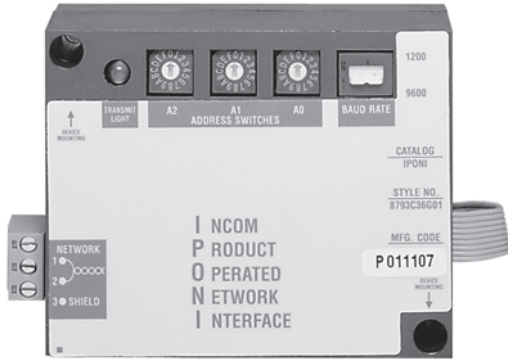

Contents

<i>Description</i>	<i>Page</i>
Power Xpert Gateways	V3-T9-259
Power Xpert Ethernet Switches	V3-T9-272
Power Xpert Gateway Series 1000 Card—Power Distribution Unit	V3-T9-276
Power Xpert Gateway Series 2000 Card—Uninterruptible Power Supplies mMINT	V3-T9-279
MINTII RS-232 Converter.	V3-T9-282
IPONI DPONI	V3-T9-284
MPONI	V3-T9-286
I/O Devices Digital Input Module (DIM)	V3-T9-287
Addressable Relay II.	V3-T9-288
Breaker Interface Module II (BIM II)	V3-T9-290
Sub-Network Master Local Display (SMLD).	V3-T9-293
IMPCABLE	V3-T9-297

IPONI

Product Selection Guide

IPONI Selection Chart

Description	IPONI	INCOM on Product	MPONI
IQ Analyzer	Š1.06	—	■
IQ DP-4000	■	—	■
IQ 200	—	■	—
IQ Multipoint Energy Submeter II	—	■	—
Energy Sentinel	—	■	—
Power Sentinel	—	■	—
IQ Generator	■	—	—
IQ Data	■	—	—
IQ Data Plus II	—	—	—
IQ 500	—	—	—
IQ Transfer	■	—	—
AEMII	■	—	—
BIM II	■	—	—
CMU	■	—	—
CED	■	—	—
MP-3000	■	—	■
Digitrip 3000	—	■	—
FP-5000	—	■	—

Product Description

The INCOM Product Operated Network Interface card, or IPONI card, adds communication capability to various Eaton products. Each IPONI has three 16-digit address switches to uniquely identify each device on the network. IPONIs are designed to be daisy-chained throughout a unit substation or equipment room to a master device such as a mMINT, MINTII or Power Xpert Gateway. From the master computer, information is distributed through the facility's TCP/IP Ethernet network. A twisted shielded pair network connecting IPONIs may extend up to 10,000 feet (3048m) before terminating a master device. The IPONI comes with mounting hardware and attaches to the back of its associated device.

Technical Data and Specifications

Temperature

- -20°C to 70°C

Humidity

- 5%–95% noncondensing

Power

- 20–30 Vdc maximum, 50 mA nominal, 100 mA maximum

Speed

- 1200 and 9600 baud

Communications

- Three-position removable terminal block for twisted shielded pair INCOM

Product Selection

IPONI Card



PONI Communication Modules

Description	Catalog Number
INCOM PONI	IPONI

Contents

Description	Page
Power Xpert Gateways	V3-T9-259
Power Xpert Ethernet Switches	V3-T9-272
Power Xpert Gateway	
Series 1000 Card—Power Distribution Unit	V3-T9-276
Power Xpert Gateway	
Series 2000 Card—Uninterruptible Power Supplies	
mMINT	V3-T9-279
MINTII RS-232 Converter	V3-T9-282
IPONI	V3-T9-284
DPONI	
MPONI	V3-T9-287
I/O Devices Digital Input Module (DIM)	V3-T9-288
Addressable Relay II	V3-T9-290
Breaker Interface Module II (BIM II)	V3-T9-293
Sub-Network Master Local Display (SMLD)	V3-T9-297
IMPCABLE	V3-T9-299

DPONI

Product Description

The DeviceNet Product Operated Network Interface (DPONI) enables communication between a DeviceNet network master station and a host device in a Master/Slave format over a DeviceNet network. The DPONI is compatible with the MP-3000 and the MP-4000. The DPONI is powered both by the host product to which it is attached and by the DeviceNet network. The DPONI uses opto-couplers to isolate the two power systems.

The DPONI communicates at 125, 250 or 500 Kbps selected via a front panel DIP switch. All products on the DeviceNet network must be set at the same communication rate.

The DPONI has a bi-color network/module status LED that functions in accordance with the DeviceNet specification. An additional monochrome LED flashes while the DPONI is receiving a message from the host device.

Features

Eaton's DPONI

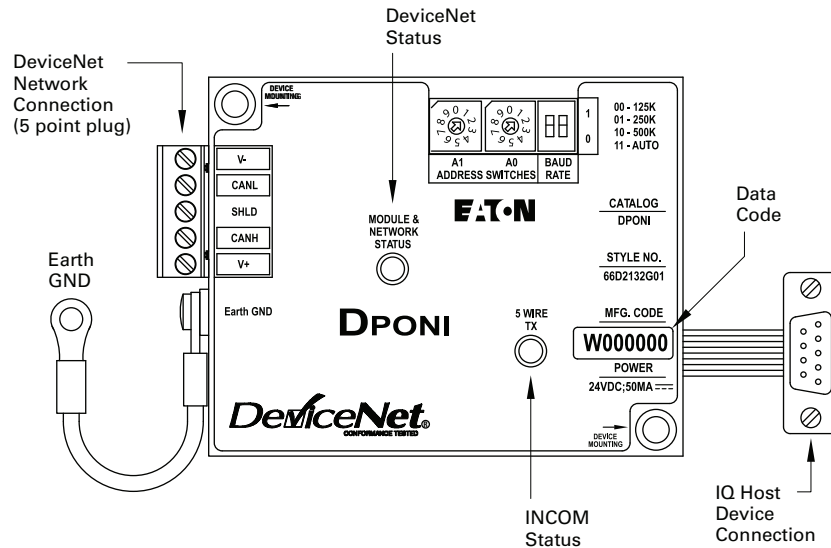

Product Selection

DPONI

Description	Catalog Number
The DeviceNet Product Operated Network Interface	DPONI

Technical Data and Specifications

Temperature

- -20°C to 70°C

Humidity

- 5%–90% noncondensing

Power

- 11–27 Vdc, 40 mA maximum

Speed

- 125, 250 or 500 Kbps

Communications

- Standard five-wire CAN connection

Contents

<i>Description</i>	<i>Page</i>
Power Xpert Gateways	V3-T9-259
Power Xpert Ethernet Switches	V3-T9-272
Power Xpert Gateway	
Series 1000 Card—Power Distribution Unit	V3-T9-276
Power Xpert Gateway	
Series 2000 Card—Uninterruptible Power Supplies	
mMINT	V3-T9-282
MINTII RS-232 Converter.	V3-T9-284
IPONI	V3-T9-285
DPONI	V3-T9-286
MPONI	
I/O Devices Digital Input Module (DIM)	V3-T9-288
Addressable Relay II.	V3-T9-290
Breaker Interface Module II (BIM II)	V3-T9-293
Sub-Network Master Local Display (SMLD).	V3-T9-297
IMPCABLE	V3-T9-299

MPONI

Product Description

The MPONI Product Operated Network Interface card, or MPONI card, enables Modbus communication capability to various Eaton products. Each MPONI contains two rotary address switches to uniquely identify each device on the network and a baud rate DIP switch. A 5-pin connector is provided for wiring to the RS-485 network. Various baud rates are available for networking flexibility, and onboard LEDs indicate operation, error and communication status. The MPONI is applied where a device network exists connected by a dedicated shielded twisted pair conductor. Modbus RS-485 allows a single device or multiple units in a daisy-chain configuration to communicate with another local or remote device and may extend up to 4000 feet (1219m) without a repeater. The MPONI comes with mounting hardware and attaches to the back of its associated device.

Note: Please see IL for detailed register support information for each supported product. Not all device functionality is supported with the RS-485 PONI over the Modbus Protocol.

Features

MPONI

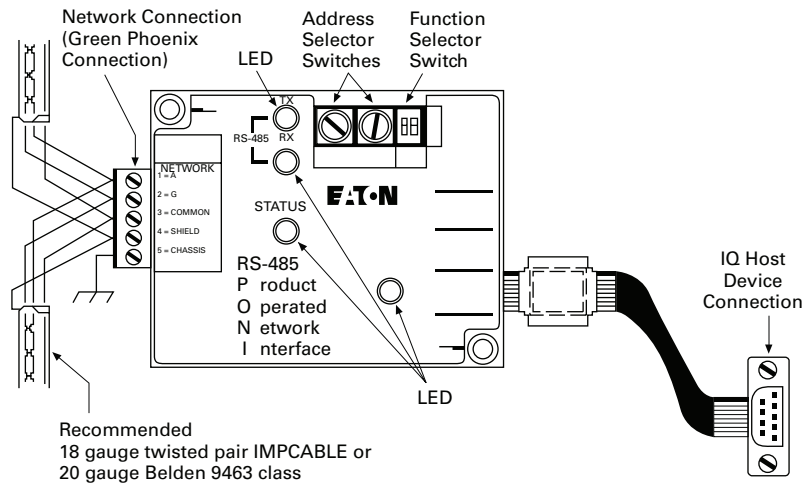

Recommended
18 gauge twisted pair IMPCABLE or
20 gauge Belden 9463 class

Product Selection

MPONI

Description	Catalog Number
Modbus Product Operated Network Interface Card	MPONI

Digital Input Module (DIM)



9

Contents

<i>Description</i>	<i>Page</i>
Power Xpert Gateways	V3-T9-259
Power Xpert Ethernet Switches	V3-T9-272
Power Xpert Gateway	
Series 1000 Card—Power Distribution Unit	V3-T9-276
Power Xpert Gateway	
Series 2000 Card—Uninterruptible Power Supplies	V3-T9-279
mMINT	V3-T9-282
MINTII RS-232 Converter	V3-T9-284
IPONI	V3-T9-285
DPONI	V3-T9-286
MPONI	V3-T9-287
I/O Devices Digital Input Module (DIM)	
Product Selection	V3-T9-289
Technical Data and Specifications	V3-T9-289
Dimensions	V3-T9-289
Addressable Relay II	V3-T9-290
Breaker Interface Module II (BIM II)	V3-T9-293
Sub-Network Master Local Display (SMLD)	V3-T9-297
IMPCABLE	V3-T9-299

I/O Devices Digital Input Module (DIM)

Product Description

Eaton's Digital Input Module is a device that interfaces with up to four standard utility (electric, gas, water) meters or monitors eight digital inputs. It translates KYZ pulses from meters into a register count that is maintained and compiled within the DIM module in non-volatile memory. The pulse count can be accessed from the DIM module remotely using Eaton Power Management Software, including the Energy Billing application.

The DIM can also be used to monitor eight digital inputs from switch closures.

Features, Benefits and Functions

- Reads four separate KYZ equipped utility meters
- Pulse counts stored in non-volatile memory
- Each channel independently monitors KYZ counts, pulse counts, or digital indications
- Monitors a maximum of eight individual digital inputs
- Input channels are isolated
- Isolated 24 Vdc power is provided on the I/O connector
- LED indicators on the input channels indicate when the unit is counting
- 10 LED status indicators, 100 ohm termination DIP switch, address selector switches
- DIN rail mounting

Standards and Certifications

- UL 873
- CE mark (48 Vdc operation)
- FCC Part 15, Class A
- IEC 1000-4-x
- CISPR 22, Class A
- IEC 1000-4-2; 1995, Electro Static Discharge
- IEC 1000-4-3; 1995, Radiated RF Immunity
- IEC 1000-4-6; 1996, Conducted RF Immunity
- FCC Part 15 Class A (10 meters) Radiated Emissions
- CISPR 22, Class A (30 meters); 1991, Radiated Emissions
- CISPR 22, Class A; 1991, Conducted Emissions (PowerPort)



Product Selection

DIM



Ordering Information

Description	Catalog Number
Digital Input Module	DIM

Technical Data and Specifications

Specifications

Description	Rating
Operating temperature	-20°C to 60°C
Storage temperature	-20°C to 70°C
Operating Humidity	5 to 90% maximum noncondensing
Altitude	10,000 ft. (3048m)
Environment	Indoor use only
Transient overvoltage	Category 2
Pollution	1°
Equipment	Class 1

Frequency Range

- 50/60 Hz

Power

- 85 to 138 Vac (120 Vac nominal) 50/60 Hz; 100 mA
- 48–128 Vdc (48 Vdc nominal); 100 mA
- Brownout operation at 50% and 80% of nominal AC and DC ratings
- Power input is provided from a limited source, isolated from the mains by double isolation
- Power for all inputs is supplied from an internal, isolated 24 Vdc power source

Mounting Information

The DIM module is designed to be DIN rail mountable. DIN rail must be 1/3 inches H x 1-3/8 inches W (8.5 mm H x 34.9 mm W).

Communications

The DIM is a fully compatible Power Management Software communicating device with built-in INCOM communications. The DIM comes complete with a 3-pin connector to receive the shielded twisted pair conductor.

All wiring must be complete as per Instruction Leaflet TD17513, Wiring Specification Base Rules.

Dimensions

Approximate Dimensions in Inches (mm)

KYZ Input Module

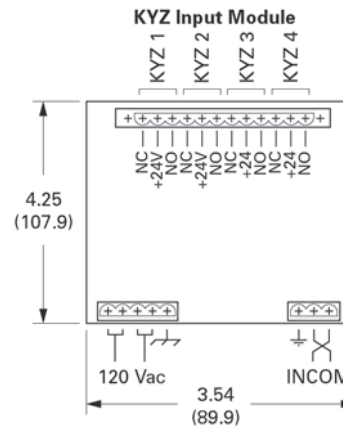

KYZ Input Module

Width	Height	Depth
3.54 (89.9)	4.25 (107.9)	3.50 (88.9) ①

Note

- ① Does include DIN rail.

Addressable Relay II



Addressable Relay II

Product Description

The Addressable Relay II is designed for use where information or control of non-communicating devices is required remotely. The relays communicate at 9600/1200 baud on the INCOM network. Devices are assigned a three-digit address to uniquely identify them on the daisy-chained twisted shielded pair network.

The Addressable Relay II is a Form C relay on terminals 1, 2 and 3, with output contact ratings as shown in the Contact Ratings table. The Addressable Relay II may be powered by 48–120 Vac or 48–125 Vdc through terminals 11 and 12 of the terminal block. DC polarity is not significant.

Application Description

- Enables remote control of non-communication capable devices on Eaton's PowerNet system
- Monitors two digital status inputs on the PowerNet system

Features, Benefits and Functions

Each Addressable Relay II includes two status indicating circuits (IN1 and IN2) that can be used to transmit the contact status of devices external to the Addressable Relay II. Each input is isolated with its own return. A typical installation using these report-back inputs to the Eaton PowerNet system is shown in the wiring example. Terminals 4 and 5 connect to the status input 1 circuit (IN1) and terminals 6 and 7 connect to the status input 2 circuit (IN2). These status indicating circuits operate with input voltages of 48–120 Vac or 48–125 Vdc circuits.

Contents

Description

	<i>Page</i>
Power Xpert Gateways	V3-T9-259
Power Xpert Ethernet Switches	V3-T9-272
Power Xpert Gateway	
Series 1000 Card—Power Distribution Unit	V3-T9-276
Power Xpert Gateway	
Series 2000 Card—Uninterruptible Power Supplies	V3-T9-279
mMINT	V3-T9-282
MINTII RS-232 Converter	V3-T9-284
IPONI	V3-T9-285
DPONI	V3-T9-286
MPONI	V3-T9-287
I/O Devices Digital Input Module (DIM)	V3-T9-288
Addressable Relay II	
Product Selection	V3-T9-291
Technical Data and Specifications	V3-T9-291
Dimensions	V3-T9-292
Breaker Interface Module II (BIM II)	V3-T9-293
Sub-Network Master Local Display (SMLD)	V3-T9-297
IMPCABLE	V3-T9-299

The Addressable Relay II includes a feature called the “communications watchdog.” The communications watchdog monitors communications between the Addressable Relay II and the computer control station. If communications are lost, the communications watchdog will reset the relay to the de-energized (OFF) state. The Addressable Relay II must be updated every 10 seconds when the communications watchdog is enabled or else communications are assumed to be lost. The communications watchdog is enabled when DIP switch 3 is set to the ON position. When the communications watchdog is not enabled, the relay will remain in the state set by the last command issued. **See V3-T9-296** for DIP switch configuration.

Monitored Parameters

- Output relay energized/de-energized
- Input 1 status
- Input 2 status
- Breaker status open/closed
- Protective relay status normal/tripped

Communications

- Built-in INCOM communications for monitoring in Eaton's PowerNet system

The Addressable Relay II also includes a feature called “relay pulse.” The relay pulse feature sets the Addressable Relay II to a pulse mode where the relay is energized (ON) for 10 seconds and then is de-energized (OFF). The relay pulse is enabled when DIP switch 2 is set to the ON position and disabled when DIP switch 2 is set to the OFF position. If this feature is not enabled, the relay will remain in the state set by the last command.

Product Selection

Addressable Relay II

Addressable Relay



Description	Catalog Number
Addressable Relay II	ARII

Technical Data and Specifications

- Power: 48–120 Vac; 48–125 Vdc
- Operating temperature range: 32°–158°F (0°–70°C)

Contact Ratings

Contact Ratings	Make	Break
120–240 Vac	4960 VA	828 VA
24–120 Vac	43A	7.2A
30 Vdc	10A	10A

Wiring Diagram

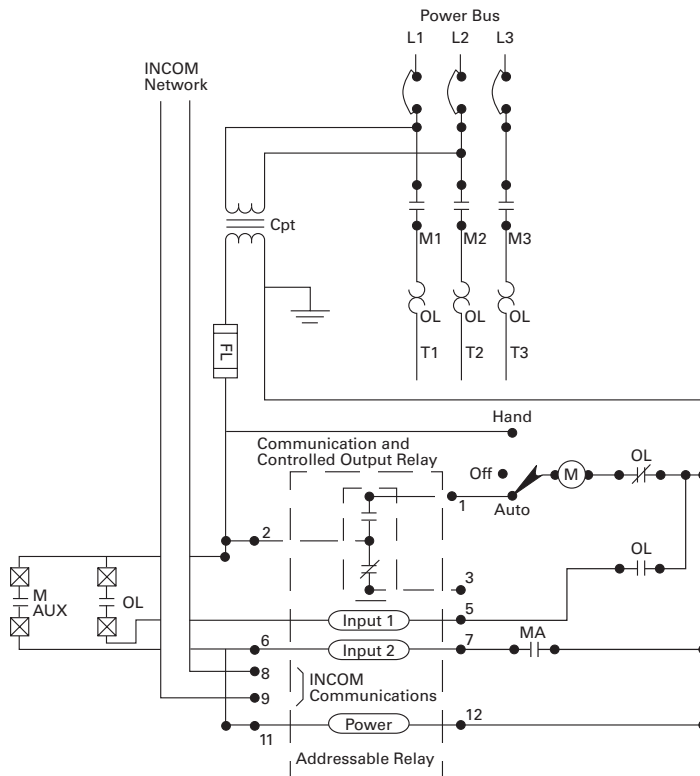

DIP Switch Functions

	OFF	ON
Baud Rate	9600	1200
Relay Pulse	Disabled	Enabled
Communications Watchdog	Disabled	Enabled

Dimensions

Approximate Dimensions in Inches (mm)

Mounting

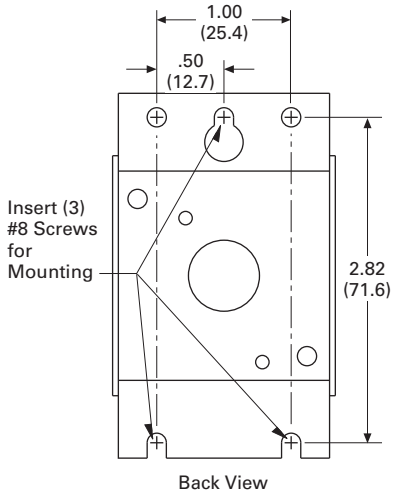

Addressable Relay

Width	Height	Depth
1.75 (44.5)	3.00 (76.2)	4.00 (101.6)

Breaker Interface Module II (BIM II)



Contents

<i>Description</i>	<i>Page</i>
Power Xpert Gateways	V3-T9-259
Power Xpert Ethernet Switches	V3-T9-272
Power Xpert Gateway	
Series 1000 Card—Power Distribution Unit	V3-T9-276
Power Xpert Gateway	
Series 2000 Card—Uninterruptible Power Supplies	V3-T9-279
mMINT	V3-T9-282
MINTII RS-232 Converter	V3-T9-284
IPONI	V3-T9-285
DPONI	V3-T9-286
MPONI	V3-T9-287
I/O Devices Digital Input Module (DIM)	V3-T9-288
Addressable Relay II	V3-T9-290
Breaker Interface Module II (BIM II)	
Features, Benefits and Functions	V3-T9-294
Product Selection	V3-T9-295
Technical Data and Specifications	V3-T9-295
Sub-Network Master Local Display (SMLD)	V3-T9-297
IMPCABLE	V3-T9-299

Breaker Interface Module II (BIM II)

Product Description

Eaton’s Breaker Interface Module is a panel-mounted device that displays the following parameters.

- Phase current
- Energy
- Present demand watts
- Peak demand watts
- Average demand current
- Cause and magnitude of trip
- Trip history
- % Total Harmonic Distortion (THD) for each phase
- % Harmonic Content for each phase (1st–27th harmonic)
- Custom circuit description

Note: The Breaker Interface Module displays only a portion of the information it receives from the Digitrip RMS 910, 1150 and Power Sentinels. The balance of the information (such as Waveform Analysis and Power Factor) can be passed through the unit to a master computer, where it can be viewed.

Application Description

- 810, 910, 750, 1050, 550, 1150, 520MC, IQ Energy Sentinels and Power Sentinels
- Event logging
- Alarming
- High load indication
- Peak exceeded alarm
- Grouping of meters

An operator can use the Breaker Interface Module to:

- Complete Initial System Setup:
 - Select system frequency (50/60 Hz)
 - Set password
- Configure OPTIM Protective Settings:
 - Select protection options
 - Select alarm levels
- Display Information:
 - Metered values
 - Trip event information
 - Breaker information
 - Time-current set points

- Test OPTIM Trip Unit Performance:
 - Phase and ground
 - Trip/no trip
- Expanded Energy Monitoring:
 - Set addresses for group energy monitoring
 - Group energy readings
- Local and Remote Indication:
 - Remote indication/alarming
 - Breaker status LED indication
- Expanded Communications:
 - Communicate with:
 - OPTIM Trip Units
 - Digitrip RMS 810, 910 and 1150 Trip Units
 - IQ Energy Sentinels and Universal IQ Energy Sentinels
 - A total of 50 devices

Features, Benefits and Functions

- Monitors and displays parameters from any combination of Digitrip RMS 810, 910, 1150 and Digitrip OPTIM Trip Units, F-/J-/K-Frame Energy Sentinels, and Universal Energy Sentinels, supporting as many as 50 of these devices up to 10,000 feet (3048 m) away
- Communicates the information from these protective and energy monitoring devices over Eaton INCOM network to a computer or PLC
- Continuously monitors breakers recording and time-stamping trip events along with approximate fault currents. Events are logged into non-volatile RAM

Physical Characteristics

- Graphical, glass plasma display
- Up to seven lines of information
- Membrane faceplate NEMA 3R and 12 rated

Communications

Depending upon the type of communication protocol used by the main network, an appropriate PON1 module can be easily field-mounted to the back of the Breaker Interface Module, enabling the unit to pass the information from its subnetwork to a remote master control unit up to 10,000 feet (3048 m) away. No reprogramming of the unit is required when the PON1 is added.

The Breaker Interface Module can be mounted directly on the assembly or at a remote location and can be used to access and configure and display information from OPTIM Trip Units.

Password Protection

A user-defined password is included for added security when changing settings or performing breaker tests.

Non-Volatile Memory

The programmed functions, addresses and circuit descriptions are stored in non-volatile memory.

External Power

A 24 Vdc supply is required for the BIM II. (No external power supply is required for the PON1 Card.) A 120 or 240 Vac supply is required for the BIMPS.

Rear Access Area

All wiring connections to the Breaker Interface Module are made at the chassis' rear and include:

- Relay connection for "alarm" condition, "high load" condition, "peak exceed" for device or group, and watthour pulse
- Initiator
- 24 Vdc input—BIM II
- 120 or 240 Vac input—BIMPS
- DIP switches for selecting an operating mode
- Three-contact connector with subnetwork
- Connector for PON1 card for remote communications Local Display Units

Product Selection

Breaker Interface Module II (BIM II)



Breaker Interface Module

Description	Catalog Number
Breaker Interface Module	BIMII
	BIMPSII

Technical Data and Specifications

Power Requirement

- 15 VA maximum

Input Voltage

- 24 Vdc $\pm 5\%$ —BIM II
- 120 or 240 Vac $\pm 10\%$ —BIMPS

Operating Temperature

- 0°C to 70°C (32°C to 158°F)

Humidity

- 5% to 95% R.H. (noncondensing)

Alarm Contact Ratings

- 10A at 277 Vac (resistive)
- 10A at 30 Vdc (resistive)
- 1/3 hp at 125, 250 Vac

Dimensions

Approximate Dimensions in Inches (mm)

Connections and DIP Switch Rear Label Diagram

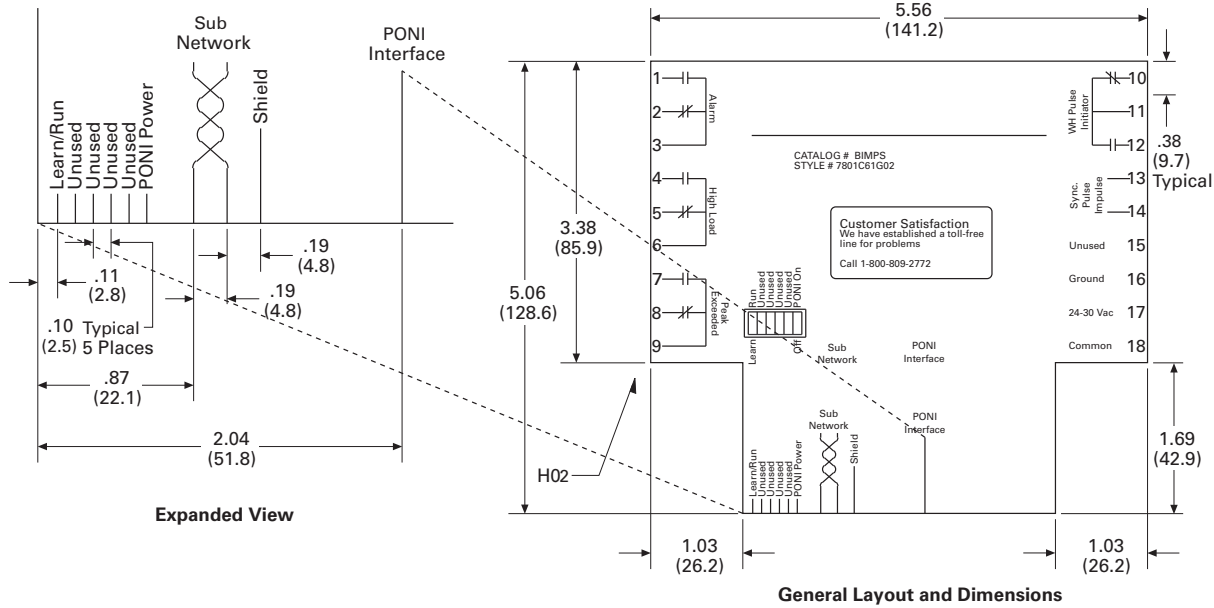

Breaker Interface Module

Height	Width	Depth
Without Communications Card		
6.72 (170.7)	10.25 (260.4)	2.60 (66.0)
With Communications Card		
6.72 (170.7)	10.25 (260.4)	3.85 (97.8)

Drilling Pattern

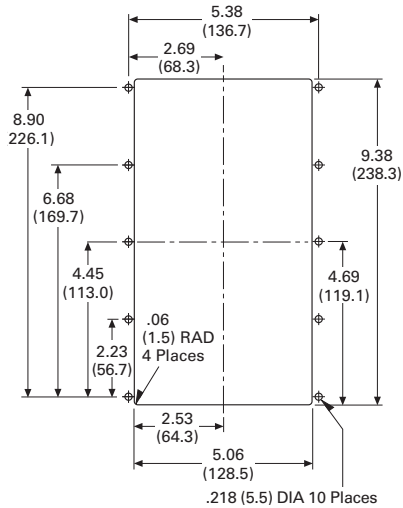

Sub-Network Master Local Display)



Contents

<i>Description</i>	<i>Page</i>
Power Xpert Gateways	V3-T9-259
Power Xpert Ethernet Switches	V3-T9-272
Power Xpert Gateway	
Series 1000 Card—Power Distribution Unit	V3-T9-276
Power Xpert Gateway	
Series 2000 Card—Uninterruptible Power Supplies	V3-T9-279
mMINT	V3-T9-282
MINTII RS-232 Converter.	V3-T9-284
IPONI	V3-T9-285
DPONI	V3-T9-286
MPONI	V3-T9-287
I/O Devices Digital Input Module (DIM)	V3-T9-288
Addressable Relay II.	V3-T9-290
Breaker Interface Module II (BIM II)	V3-T9-293
Sub-Network Master Local Display (SMLD)	
Product Selection	V3-T9-298
Technical Data and Specifications	V3-T9-298
Dimensions	V3-T9-298
IMPCABLE	V3-T9-299

Sub-Network Master Local Display (SMLD)

Product Description

Eaton’s Sub-Network Master Local Display (SMLD) is an electronic submetering device that provides users the ability to view information from sub-network connected devices locally at switchgear, switchboards, panelboards, motor control centers and control panels, nearby or thousands of feet away. The SMLD has a built-in LCD display with navigations for configuring, as well as monitoring. Auto-learn capabilities complete the configuration requirements, enabling customization by use of user-defined descriptions, as well as adding and deleting meters.

The SMLD can be operated standalone or in parallel with the new FetchIT™ software application or the Power Xpert complete energy monitoring system solution software.

Application Description

- Acquire and display data (no control) from up to 100 devices that can communicate on Eaton’s INCOM network, used in the PowerNet monitoring system

Features, Benefits and Functions

- Auto-learn connected devices
- Configuration stored in non-volatile memory
- Host communications arbitration algorithm enables seamless integration into existing communication networks
- Functions standalone or networked

- Following devices are supported:
 - IQ 200
 - IQ Multipoint Energy Submeter II
 - IQ Energy Sentinel (F, J, K Frames)
 - Universal Internal Energy Sentinel
 - Universal External Energy Sentinel
 - IQ Power Sentinel
 - Digitrip OPTIM 1050L

Standards and Certifications

- Safety Standards—UL 61010B-1
- EMC Susceptibility Standards—IEC 1000-4-3, 1995 Radiated RF Immunity
- EMC Emissions Standards—FCC Part 15, Class B Radiated Emissions



Physical Characteristics

- Keypad functions:
 - Menu
 - Scroll up
 - Scroll down
 - Enter
- Backlit LCD, 4-line x 20 character

Product Selection

Sub-Network Master Local Display



Ordering Information

Description	Catalog Number
Local Display (120 Vac)	LDISP120
Local Display (24 Vac or Vdc)	LDISP24

Technical Data and Specifications

Frequency Range

- 50/60 Hz

Power

- Power consumption: 200 mA (maximum) at 24 Vac, 24 Vdc
- Power connector rating: 24 Vac or 24 Vdc at 1 ampere
- Power source: 120 Vac or 24 Vdc, UL Class 2 or CSA Class III SELV transformer in accordance with C22.2 No. 1010-1. The voltage range is 18 to 24 Vac or Vdc, 200 mA (maximum)

Ratings

- Operating temperature: 0°C to 60°C
- Storage temperature: -20°C to 70°C
- Operating humidity: 5 to 90% maximum non-condensing
- Altitude: 10,000 feet (3048m)
- Environment: indoor use only

Mounting Information

- 4.37 H x 4.37 W x 1.50 D inches (111.0 H x 111.0 W x 38.1 D mm)
- Door mount or panel mount

Communications

- INCOM Frequency Shift Key (FSK) network compatible 9600 baud
- Non-intrusive arbitration algorithm
- Passive monitoring automatically enabled by arbitration algorithm while host PC is communicating
- Master on INCOM network upon data request from front panel if host PC is not communicating
- Addresses for sub-network devices can be 001-044 hex (1-255 decimals)

Typical Use Diagram of SMLD

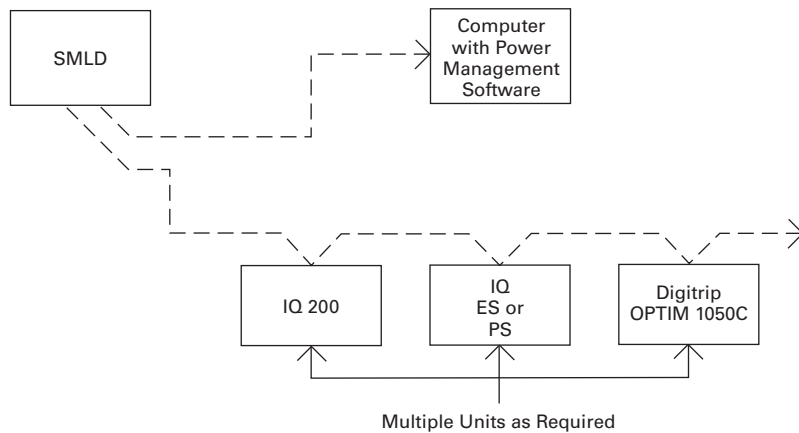

Dimensions

Approximate Dimensions in Inches (mm)

Meter Base Unit

Width	Height	Depth
4.37 (111.0)	4.37 (111.0)	1.50 (38.1)

Note

DIN (92 mm x 92 mm) access cutout.

IMPCABLE

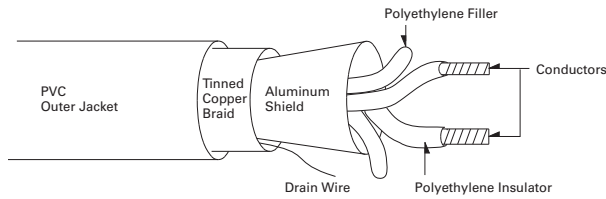

Contents

<i>Description</i>	<i>Page</i>
Power Xpert Gateways	V3-T9-259
Power Xpert Ethernet Switches	V3-T9-272
Power Xpert Gateway Series 1000 Card—Power Distribution Unit	V3-T9-276
Power Xpert Gateway Series 2000 Card—Uninterruptible Power Supplies mMINT	V3-T9-279
MINTII RS-232 Converter	V3-T9-282
IPONI	V3-T9-285
DPONI	V3-T9-286
MPONI	
I/O Devices Digital Input Module (DIM)	V3-T9-288
Addressable Relay II	V3-T9-290
Breaker Interface Module II (BIM II)	V3-T9-293
Sub-Network Master Local Display (SMLD)	V3-T9-297
IMPCABLE	

IMPCABLE

Product Description

The IMPCABLE is an 18 AWG cable with a 100 ohm impedance at 100 kHz tuned to work optimally with the FSK signal from Eaton’s devices. The cable has been designed with characteristics that allow up to 1000 devices or distances up to 10,000 feet (3048m) from the master.

Please refer to Eaton’s wiring specification for instructions on cable runs and calculating maximum distances and devices on a given network.

Application Description

Eaton’s IMPCABLE was designed to be run in switchgear where codes require a 600 volt insulation rating. Typical “blue hose” cables are rated at 300 volts.

Features

Physical Characteristics

- Twisted shielded pair with drain wire
- 600 volt at 80°C
- 18 AWG, 20 AWG drain UL AWM 20253

Standards and Certifications

- UL AWM 20253
- NEC XCM
- CSA
- PCC-FT1
- P-MSHA



Product Selection

IMPCABLE

Description	Catalog Number
IMPCABLE	IMPCABLE

Technical Data and Specifications

- INCOM signal: attenuation 1.6 db/1000 feet (305m)
- Long communication runs
- 600 volt required ratings

Power System Studies, Field Services and Conversions

Full Service Providers



10.1 Overview of Services	
Overview	V3-T10-2
Asset Optimization, Knowledge Management and Product Life Extension	V3-T10-5
Power Systems Automation Group	V3-T10-8
Instant Response Center Services	V3-T10-10
Customized High Resistance Grounding Units	V3-T10-11
10.2 Power System Studies	
Arc Flash, Short-Circuit and Coordination Studies	V3-T10-12
Load Flow/Power Factor Correction Study	V3-T10-15
Harmonic Analysis Study	V3-T10-17
Advanced Analysis and Design Services	V3-T10-19
10.3 Field Engineering Services	
Selection Guide	V3-T10-23
10.4 Predictive Diagnostic	
Partial Discharge Testing	V3-T10-29
Medium and High Voltage Predictive Diagnostics Online Monitoring and Partial Discharge Analysis	V3-T10-32
10.5 Retrofit Services	
Medium Voltage Vacuum Replacement Circuit Breakers	V3-T10-34
AR Series Low Voltage Replacement Breakers	V3-T10-39
Low Voltage Power Circuit Breaker Reconditioning	V3-T10-41
Arcflash Reduction Maintenance System™ Conversions	V3-T10-45
Digitrip Microprocessor Trip Unit Retrofit Kits	V3-T10-46
Low Voltage Breaker Drawout Vacuum Starter Replacement	V3-T10-50
MCC Replacement Units	V3-T10-52
10.6 Performance-Based Maintenance Services	
General Description	V3-T10-55

10.1

Power System Studies, Field Services and Conversions

Overview of Services

Experienced Professional Engineers



10

Overview

Eaton's Electrical Services & Systems (EESS) provides intelligent PowerChain™ solutions for existing, evolving, unexpected service needs. The solutions can improve electrical system reliability, reduce downtime, extend the useful life of the power distribution system, and minimize electrical operating and maintenance costs.

General Description

This organization supports consultants and end-users on new construction, integrated engineering solutions and facility expansion projects.

EESS can package a complete power distribution system with Eaton manufactured products, supplemented by other OEM components to best satisfy the end-user requirements. EESS can provide optimization of owner's electrical power assets with guarantees and savings.

Also provided is a full complement of services to maintain and modernize electrical power distribution, and process control systems.

End-users include industrials, commercial facilities, utilities, municipalities, institutions, government and military locations.

Service capabilities include:

- Turnkey project management
- System integration
- Training
- Startup and commissioning
- Predictive and preventive maintenance
- Electrical system modernization
- Circuit breaker specialized services

Division-wide capabilities support regional service centers located throughout the U.S. and Canada. Service centers are equipped with the most technologically advanced test and diagnostic equipment. The Power Systems Engineering Group uses industry standard software with advanced system modeling and analysis capabilities.

Contents

Description

Page

Overview of Services	
Overview	
Asset Optimization, Knowledge Management and Product Life Extension	V3-T10-5
Power Systems Automation Group	V3-T10-8
Instant Response Center Services	V3-T10-10
Customized High Resistance Grounding Units	V3-T10-11

In addition to the local service centers, aftermarket centers of excellence can furnish the full complement of circuit breaker specialized services.

Division-wide safety and quality programs ensure customer satisfaction, while maintaining safety as a first priority.

Experienced professional engineers, graduate engineers, field engineers and technicians are trained on both Eaton products and competitive electrical power distribution products. This cross-OEM experience allows for the application of new products and services to all manufacturer's electrical equipment.

Turnkey Project Management



Project Team

The following is a detailed listing of engineering service offerings.

- Substation design, management and construction
- Electrical, mechanical and instrumentation services
- Power system studies:
 - Short-circuit
 - Coordination
 - Arc flash
 - Load flow, etc.
- Power quality and harmonic studies
- Renewable energy design and interconnection analysis
- Failure/root-cause analysis
- CAD services
- Equipment relocation
- Turnkey transformer and capacitor replacements

System Integration and Training



Computer Diagnostics

- Plant monitoring, protection and control:
 - Digitrip™/Advantage™
 - PowerNet™/Power Xpert®
 - DeviceNet/PLC interface
- Energy management/load shedding
- Distributed generation
- Generator/emergency power systems
- PLC/PC control and open automation systems
- Drive and MCC systems training (scheduled and on-site):
 - Distribution systems analysis
 - Power quality and grounding
 - Electrical equipment maintenance
 - PLCs and drive systems
 - Customized training programs

Predictive Diagnostics



Field Data Collection

Eaton's predictive diagnostics leads the industry in predictive diagnostic tools and services. With the growing demand for reduced outages and increased uptime, online monitoring of electrical insulation systems is becoming an integral part of efficient plant maintenance in the utility, industrial and commercial markets. Eaton predictive diagnostics provides online monitoring services of insulation systems via the effective measurement and analysis of partial discharges. This allows for detection of traditional corona damage, or surface tracking, prior to equipment failure. This advanced technology is applied to medium voltage systems such as: generators, motors, switchgear, transformers and cable systems.

Services are implemented through the network of EESS field locations.

- Medium voltage generator and medium voltage motor partial discharge (PD) detection using existing RTDs with temporary or permanent sensors
- Medium voltage switchgear PD detection using temporary or permanent sensors. Permanent sensors differentiate cable-related PD to switchgear PD
- Transformers (34.5 kV primary and above) PD detection using permanent sensors connected to bushing capacitive taps
- Transformer (34.5 kV primary and above) bushing monitoring, with permanent sensors, of any change in power factor and bushing capacitance

Startup, Commissioning and Maintenance



Field Startup

- Installation support and supervision
- Acceptance testing
- Commissioning and energizing
- Startup, training and warranty support
- Exclusive Eaton products 2-year warranty
- Ground fault certifications
- Ground grid testing
- Cable testing and fault identification
- Relay testing and calibration
- PM program design and implementation
- Thermograph surveys
- Predictive, preventive maintenance and troubleshooting
 - Transformers and tap changers
 - High voltage systems
 - Substations medium and low voltage
 - Relay systems
 - Automatic transfer schemes
 - Battery systems
 - Low/medium voltage breakers
 - Motors
 - SF6, OCB, WLI components
 - Network protectors
 - Motor control centers and molded case breakers
- Drive systems
- PLC/control and open automation systems
- Nuclear Class 1E safety-related field service

Electrical System Modernization**Equipment Inspection**

- Switchgear bus MVA upgrading
- Bus insulation systems
- Medium voltage vacuum breaker roll-in replacements
- Low voltage breaker replacement
- Low and medium voltage motor starting upgrades
- Low voltage breaker (all OEMs) trip system upgrades—Digitrip
- Low and medium voltage cell retrofits
- Molded case breaker upgrades
- Motor control center buckets upgrades
- Protection, metering, and communications:
 - Low voltage breakers: Digitrip/PowerNet
 - Overload protection
 - Metering systems: IQ family
 - PowerNet implementation
 - Harmonic measurements
- Distribution and substation automation systems
- Power factor control and correction (filtered)
- Ground fault detection systems
- Surge/lightning protection systems
- Automatic transfer scheme upgrades
- Network protector service/relaying systems
- High resistance grounding and detection
- Generator voltage regulation
- Generator static excitation systems
- Cogeneration switchgear interface relaying
- Reduced voltage/soft starters
- Drive/PLC system upgrades
- Synchronous field application upgrades

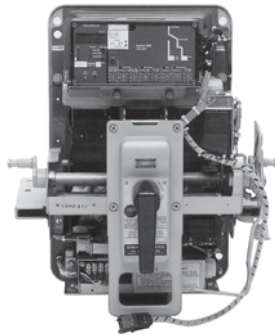
**Trip Unit Upgrade****Circuit Breaker Specialized Services**

- Low and medium voltage replacement breakers
- Low voltage retrofits (all OEMs: Digitrip RMS kits)
- Medium voltage vacuum roll-in breakers (all OEMs)
- Low and medium voltage recondition and remanufacture
- MCC recondition and remanufacture
- Network protector service
- Navy shipboard breakers
- Nuclear Class 1E safety-related circuit breakers

Manufacturer's Brand Equipment Serviced

- Cutler-Hammer®
- Westinghouse®
- Square D®
- General Electric®
- ITE®/BBC/ABB®
- Allis Chalmers/Siemens®
- Federal Pacific®
- Challenger®
- Obsolete equipment

References

Electrical System Modernization uses advanced Eaton products.

Eaton's Electrical Services & Systems (EESS)



Contents

<i>Description</i>	<i>Page</i>
Overview	V3-T10-2
Asset Optimization, Knowledge Management and Product Life Extension	
Elements of a Performance-Based Maintenance Program	V3-T10-6
Asset Optimization Services	V3-T10-6
Knowledge Management	V3-T10-7
Power Systems Engineering Solutions	V3-T10-7
Power Systems Automation Group	V3-T10-8
Instant Response Center Services	V3-T10-10
Customized High Resistance Grounding Units ...	V3-T10-11

Asset Optimization, Knowledge Management and Product Life Extension

General Description

A company's facilities exist for a single purpose: to support the mission and objectives of the company's business. It is essential that the power distribution equipment and energy assets that sustain production and services are working as efficiently and effectively as possible.

The core business of Eaton's Electrical Services & Systems (EESS) centers on power distribution and energy management.

1. We offer Powerchain Management solutions and we take care of your systems so you can take care of your business.
2. One area of the PowerChain™ is maintenance solutions.

Eaton knows that a successful maintenance program has the following characteristics:

- Enables you to schedule maintenance based on actual device operation history
- Eliminates unnecessary maintenance work and related production outages
- Reduction of spare parts requirements due to increased accuracy of equipment history
- Reduction of overall maintenance costs

Performance-Based Maintenance (PBM) Program

Eaton offers centrally coordinated management of all procurement, installation, startup and systems required to implement powerful solutions. Whether you have a single site or multiple sites, Eaton has the solutions that fit various project needs.

The PBM Program offers a definitive result and at a guaranteed price. We integrate four proven maintenance programs to positively impact your key business drivers and give you high returns on investment.

1. Planned Maintenance Module: addressing operational performance, as-left conditions, environmental considerations, and testing and calibration results.
2. Predictive Diagnostic Module: focusing on visual observations, environmental and thermal conditions, and predictive indicator results.
3. Reliability-Centered Maintenance Module: concentrating on the potential for injuries, environmental hazards and product losses or process interruptions.
4. Periodic Observations Module: centering on equipment loading, and visual and environmental observations.

10.1

Power System Studies, Field Services and Conversions

Overview of Services

Getting a Performance-Based Maintenance Program Started

Getting started with a PBM Program is easy. Highly qualified EESS engineers visit your facility and perform a comprehensive site audit and needs assessment. While implementing electrical system testing and maintenance, EESS engineers review both the “condition” and the “criticality” of each component with plant personnel.

The condition is determined via traditional preventive maintenance procedures (industry-standard, time-based) combined with predictive diagnostic technologies. The criticality rating of each component is established through application of a reliability-centered maintenance approach, taking into account its potential impact on critical processes, safety and the environment.

Then, EESS recommends a maintenance interval (short-, mid- or long-term) for each component, as well as work scopes and periodic observation frequency.

Cost savings are realized when the long-term maintenance interval is lengthened or by the scope of maintenance work during scheduled outages is reduced. Uptime and reliability improve when preventive maintenance is performed more frequently on components with the short-term designation. Additional reliability improvements can result from redirecting some of the savings to performing additional predictive diagnostics and equipment modernization.

EESS delivers a periodic scorecard to plant personnel, summarizing the recommendations, performance and results of the program.

Elements of a Performance-Based Maintenance Program

- Site audit and maintenance needs assessment
- Condition-based maintenance
- Reliability centered maintenance (RCM)
- Predictive diagnostics
- Efficient algorithms to integrate equipment condition results, RCM input, predictive diagnostics and periodic observations
- Recommendations for immediate action, automation, remote monitoring, life extension, spare parts or upgrading
- Periodic observations while energized and operating
- Maintenance implemented based on equipment condition and criticality
- Root-cause failure analysis
- Periodic scorecard and customized reporting of results
- Continuous improvement
- Optional ensured performance improvements and ensured savings—typically, 15% savings over two performance cycles

Asset Optimization Services

The Electrical Distribution System (EDS) not only represents a significant capital investment, it is essential to maintaining production and critical processes. In order to ensure the maximum possible return on this investment and ensure that power to critical processes is maintained, EESS offers a suite of asset optimization services. This is not just a maintenance program—we combine years of EDS experience, as well as power system engineering and power quality expertise, with the latest in predictive diagnostic and remote monitoring, and knowledge management technology, to deliver a comprehensive program designed to optimize EDS assets. This means lower operating and maintenance costs and improved system reliability and uptime. By outsourcing responsibility for the electrical distribution system assets to EESS, owners can focus on their core business while we deliver maximum return on your investment via increased uptime and decreased operation and maintenance costs. Energy management services and performance contracts are also available by which we will guarantee specific measurable results related to energy savings, system uptime, equipment reliability, and operation and maintenance cost reductions.

With a reputation as the best-in-class power solution strategists, it is obvious why more and more industry leaders are turning to Eaton for uncompromising safe and reliable electrical power distribution systems, in the PowerChain.

By providing the right technology and intellectual resources through outsourcing the ownership, operation and maintenance of the plant electrical distribution system, value can be realized in three areas:

1. Capital funds previously spent on non-core assets are made available to invest in core processes and/or increase shareholder value.
2. Operation and maintenance costs (salary/benefits; risk and insurance related to NFPA and OSHA; training; engineering and purchasing/procurement; test equipment; tools; safety equipment; and parts inventory) are significantly reduced or eliminated completely.
3. Performance guarantees and service level agreements related to uptime, energy, and operating and maintenance costs are realized.

10

PBM Program Flowchart

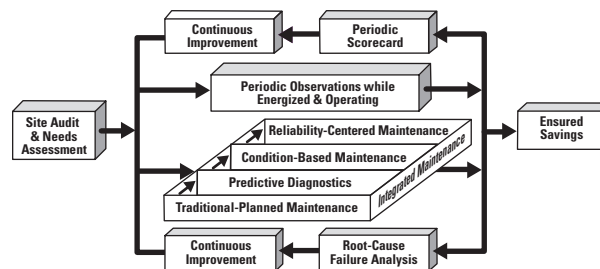

Knowledge Management

Eaton has the expertise for electrical distribution systems with a variety of technologies and expert analytical services through our Instant Response CenterSM. We aggregate data gathered from your system and use the information to predict equipment failure and identify energy cost reduction opportunities.

Our practices can help you:

- Increase uptime:
 - Avoid outages by predicting equipment failure or system problems
 - Decrease duration of outages (remote troubleshooting 24/7)
- Reduce operating and maintenance costs:
 - Service equipment based on real-time information rather than traditional time-based maintenance
 - Better maintenance with less man-hours
- Reduce energy costs:
 - Optimize utility rate structure
 - Automated demand management
 - Energy usage accountability

Power Systems Engineering Solutions

Not only do we have one of the largest teams of power systems engineers strategically located throughout the world, but many of these professionals have influenced industry standards and are sought after because of their expertise. With an emphasis on precision and accuracy, Eaton's highly trained engineers provide the most focused and systematic approach available to enhance your system's performance. Your system can save you money and increase productivity while meeting the growing and changing demands of your business.

Through surveys, studies, predictive maintenance solutions, energy management, monitoring and evaluation Eaton will help you:

- Maintain IEEE recommended power quality levels, including proper operating voltages
- Reduce costly system disturbances
- Minimize harmonic disturbances created by nonlinear loads
- Provide arc flash levels and personal protective equipment to develop customer safety programs
- With virtually all types of software packages

We offer more than 15 standard and specialized power system studies to precisely target and help correct your specific power issues, utilizing a variety of measurement instruments and specialized software packages.

PSA Group



Contents

<i>Description</i>	<i>Page</i>
Overview	V3-T10-2
Asset Optimization, Knowledge Management and Product Life Extension	V3-T10-5
Power Systems Automation Group	
General Capabilities	V3-T10-9
Instant Response Center Services	V3-T10-10
Customized High Resistance Grounding Units ...	V3-T10-11

Power Systems Automation Group

General Description

The Power Systems Automation (PSA) group is a full-service systems integrator. Eaton ensures your hardware, software and communication networks perform as a seamless system. PSA provides a unique alternative to conventional manufacturer-integrator-contractor teams by:

- Offering project management and single-point responsibility direct from a major manufacturer of power management and control systems
- Providing unsurpassed expertise in power management and power system control applications across a broad range of industries and end users
- Focusing on applying new products effectively and appropriately, and integrating seamlessly with all major manufacturers' equipment, new or existing

- Bringing a wide range of Eaton resources into a project to address geographic and technical challenges, and managing subcontractors and manufacturers to handle products and services not provided directly by Eaton's Electrical Services & Systems

PSA provides turnkey systems integration projects including system design, programming, panel building, installation, project management, startup, customer training and complete documentation—integrating Eaton's and all major OEM's hardware, software and systems. The following is a summary of services.

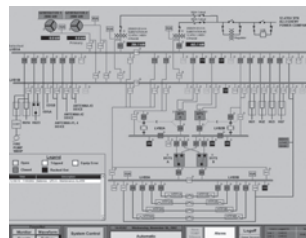

Example of a Fully Automated Generator Paralleling and Emergency Power Transfer Scheme for a Mission-Critical Application

Power Systems Automation

- Power monitoring, management and control systems
- Eaton's Power Xpert, Foreseer and PowerNet Systems including Power Xpert Reporting
- Energy cost allocation
- Lighting management systems (Eaton Pow-R-Command™)
- Load management systems
- Load shed and load transfer schemes
- Generator paralleling systems
- Backup and emergency generation systems
- Demand management systems
- Generator and ATS system monitoring control and remote testing
- Utility rate plan optimization
- Health care emergency power supply systems monitoring
- Web-based monitoring services

General Capabilities

- Power Xpert
- Foreseer
- System design—functional specification
- System network architecture
- CAD drawings
- PC control and open automation
- DeviceNet™ applications
- Open protocol systems
- PLC design and programming:
 - Eaton
 - Allen-Bradley®
 - Modicon®
 - GE Fanuc®
 - Siemens
- Human machine interface/graphical user interface design and configuration:
 - Eaton PanelMate® and PanelMate PC
 - ICONICS GENESIS® and WebHMI®
 - Wonderware®
 - Intellution
 - PanelView™ and RSVIEW™
 - Citect
 - CIMPLICITY
- Full service custom panel shop:
 - UL® listing for industrial control panels
 - Motor starter panels
 - PLC enclosures and operator consoles
 - Design and testing
 - Turnkey capabilities
- Project management—contractors, systems integrators, other OEMs, etc.
 - Installation
 - Startup and commissioning
 - Instruction manuals
 - Customized training
 - Complete documentation
 - Service contracts and maintenance agreements
 - Single-point responsibility

Eaton's Instant Response Center



Contents

<i>Description</i>	<i>Page</i>
Overview	V3-T10-2
Asset Optimization, Knowledge Management and Product Life Extension	V3-T10-5
Power Systems Automation Group	V3-T10-8
Instant Response Center Services	
Customized High Resistance Grounding Units . . .	V3-T10-11

Instant Response Center Services

General Description

Eaton's Instant Response CenterSM (IRC) is staffed by power systems engineering and power quality experts, monitoring your electrical distribution system in real-time. The IRC continuously monitors power distribution equipment for changes in performance or other conditions that could signal an impending power failure. When changes exceed predetermined thresholds, the IRC issues alerts to service personnel via Internet e-mail or wireless page.

Eaton power systems experts can then remotely and securely access real-time data from the subscriber's system, often correcting a problem before electrical service is impacted, delivering to customers a quantifiable return on investment based on maximum uptime, extended equipment lifetime, and reduced energy costs.

System outages can be prevented or mitigated, equipment life extended, and operating, maintenance and energy costs reduced by monitoring key system wellness parameters such as:

- Current, voltage and energy
- Power quality and harmonic content
- Partial discharge
- Vibration
- Temperature
- Environmental (such as presence of water)
- Power factor (transformer bushings)
- Key events (oscilligraphy)
- Energy monitoring
- Inverter monitoring
- Environmental condition monitoring

The Instant Response Center is the vanguard of Eaton's Knowledge Management Services. Knowledge management is a broad term that describes the application of a variety of related technologies and expert analytical services that transform data into information, and information into knowledge. Data is collected by remotely monitoring customers' electrical distribution and related systems via the Internet, and trending key parameters related to energy and utilities, power quality, predictive diagnostics, environment and key events. This data is converted to information through expert analysis by power systems engineering, power quality and energy management experts. This information is then transformed into knowledge using data mining techniques and the application of predictive algorithms to extract trends and patterns that will predict equipment failure and identify energy cost reduction opportunities.

Using the latest communications technologies, such as wireless videography, it is also possible to extend this high-end expertise to field technicians or customer personnel to guide them through sophisticated problem diagnosis, troubleshooting or repairs.

Benefits of IRC:

- Experts are readily available
- Eliminates the cost of bringing experts on site
- Event analysis
- No employee turnover

Oil Field HRG-3



Contents

<i>Description</i>	<i>Page</i>
Overview	V3-T10-2
Asset Optimization, Knowledge Management and Product Life Extension	V3-T10-5
Power Systems Automation Group	V3-T10-8
Instant Response Center Services	V3-T10-10
Customized High Resistance Grounding Units	

Customized High Resistance Grounding Units

Eaton’s Electrical Services & Systems builds custom medium voltage High Resistance Grounding Units (HRGUs). They eliminate the possibility of excessive transient overvoltages due to arcing ground faults on ungrounded systems. There are three categories:

- General industry—these HRGUs typically are freestanding and come with a pulsing contactor design to aid in finding the ground fault
- Medium voltage generators—new IEEE research has proven high risk for low resistance grounded generators with internal ground faults. These systems require low resistance grounding for the system, but when an internal generator ground fault occurs, massive damage can result. Eaton’s Electrical Services & Systems has developed a hybrid high resistance grounding unit (HHRG) that allows the system to be low resistance grounded for external ground faults but quickly reverts to high resistance grounded only for internal ground faults
- Oil field wells—electrical submersible pumps used in oil well applications traditionally have been designed to operate ungrounded with the expected history of insulation type failures due to arcing ground faults on ungrounded systems. These HRGU versions are custom designed to match the unique voltages, size and locations (land or platforms) for the oil field industry and supply the proven service continuity and safety high resistance grounding provides

Arc Flash, Short-Circuit and Coordination Studies



Arc Flash, Short-Circuit and Coordination Studies

General Description

Eaton's Electrical Services & Systems (EESS) can perform short-circuit and coordination studies per the following standards, and others.

- Institute of Electrical and Electronics Engineers, Inc. (IEEE):
 - IEEE 141, Recommended Practice for Electric Power Distribution for Industrial Plants
 - IEEE 242, Recommended Practice for Protection and Coordination of Industrial and Commercial Power Systems
 - IEEE 399, Recommended Practice for Industrial and Commercial Power System Analysis
 - IEEE 241, Recommended Practice for Electric Power Systems in Commercial Buildings
 - IEEE 1015, Recommended Practice for Applying Low Voltage Circuit Breakers Used in Industrial and Commercial Power Systems
- IEEE 1584, Methods for calculating flash protection boundary distance and incident energy values. Determine hazard risk category. Select protective clothing and PPE (Personal Protective Equipment)
- American National Standards Institute (ANSI):
 - ANSI C57.12.00: Standard General Requirements for Liquid-Immersed Distribution, Power, and Regulating Transformers
 - ANSI C37.13: Standard for Low Voltage AC Power Circuit Breakers Used in Enclosures
 - ANSI C37.010: Standard Application Guide for AC High Voltage Circuit Breakers Rated on a Symmetrical Current Basis
 - ANSI C37.41: Standard Design Tests for High Voltage Fuses, Distribution Enclosed Single-Pole Air Switches, Fuse Disconnecting Switches and Accessories

Contents

<i>Description</i>	<i>Page</i>
Arc Flash, Short-Circuit and Coordination Studies	
Arc Flash Analysis Details	V3-T10-14
Protective Device Coordination Study	V3-T10-13
Load Flow/Power Factor Correction Study	V3-T10-15
Harmonic Analysis Study	V3-T10-17
Advanced Analysis and Design Services	V3-T10-19

- The National Fire Protection Association 70E, National Electrical Code®, latest edition. Use methods to calculate flash protection boundary distance and incident energy values

Eaton Quality Assurance

The short-circuit and coordination studies will be conducted under the supervision and approval of a registered professional electrical engineer skilled in performing and interpreting the power system studies. The registered professional electrical engineer will be a full-time employee of EESS.

The field engineering service division can administer the power system studies, including acceptance and startup testing. Equipment and component titles used in the studies shall be identical to the equipment and component titles shown on the customer's one-line drawings. The power system studies will be performed with the aid of a digital computer program and will be in accordance with the latest applicable IEEE and ANSI standards.

Following the completion of all studies, acceptance testing and startup by EESS, a 2-year warranty will be provided on all components manufactured by Eaton.

Sequencing and Scheduling

The short-circuit and protective device coordination studies will be submitted to the design engineer prior to receiving final approval of the distribution equipment shop drawings and/or prior to release of equipment drawings for manufacturing. If formal completion of the studies may cause delay in equipment manufacturing, approval from the engineer may be requested for preliminary submittal of sufficient study data to ensure that the selection of device ratings and characteristics will be satisfactory.

Data Collection

The owner's contractor, under the direction of the equipment manufacturer, shall furnish all data as required by the power system studies. The engineer performing the short-circuit and coordination studies will furnish the equipment manufacturer and contractor with a listing of required data after award of the contract. The contractor should expedite collection of the data to ensure completion of the studies as required for final approval of the distribution equipment shop drawings and/or prior to the release of the equipment for manufacturing. Provisions shall be included by the contractor to obtain the services of the equipment manufacturer to support the proper data collection.

Fault contribution of existing motors is included in the study, with motors <100 horsepower typically grouped together. The contractor shall obtain required existing equipment data, if necessary, to satisfy the study requirements.

Short-Circuit and Protective Device Evaluation Study Details

Typical conductor impedances based on IEEE Std. 141-1993 are utilized.

Transformer design impedances are used when test impedances are not available.

The following is included as part of the study:

- Calculation methods and assumptions
- Selected base per unit quantities
- One-line diagram of the system being evaluated
- Source impedance data, including electric utility system and motor fault contribution characteristics
- Tabulations of calculated quantities
- Results, conclusions and recommendations

A calculation of short-circuit momentary and interrupting duties for a three-phase bolted fault is made for the following locations:

- Electric utility's supply termination point
- Incoming switchgear
- Unit substation primary and secondary terminals
- Low voltage switchgear
- Motor control centers
- Standby generators and automatic transfer switches
- Branch circuit panelboards
- Other significant locations throughout the system

For grounded systems, a bolted line-to-ground fault current study for areas as defined for the three-phase bolted fault short-circuit study will be provided.

Protective Device Evaluation

The protective device evaluation portion of the study will:

- Evaluate equipment and protective devices short-circuit ratings and compare to calculated available fault current
- Determine the adequacy of switchgear, motor control centers, and panelboard bus bars to withstand short-circuit stresses
- Determine the adequacy of transformer windings to withstand short-circuit stresses
- Determine the adequacy of cable and busway sizes to withstand short-circuit heating
- Notify owner in writing, of existing circuit protective devices improperly rated for the calculated available fault current

Protective Device Coordination Study

- Proposed protective device coordination time-current curves will be displayed on log-log
- Included on each curve sheet will be a complete title and one-line diagram with legend identifying the specific portion of the system covered
- The device characteristic curves will be terminated at a point reflecting maximum symmetrical or asymmetrical fault current to which device is exposed
- Identification of the device associated with each curve by manufacturer type and function, and generated using a commercially available software program

The following characteristics will be plotted on the curves, where applicable:

- Electric utility's protective device
- Medium voltage equipment relays
- Medium and low voltage fuses, including manufacturer's minimum melt, total clearing, tolerance and damage bands
- Low voltage equipment circuit breaker trip devices, including manufacturer's tolerance bands
- Transformer full-load current, magnetizing inrush current and ANSI transformer withstand parameters
- Conductor damage curves
- Ground fault protective devices, as applicable
- Pertinent motor starting characteristics and motor damage points
- Pertinent generator short-circuit decrement curve and generator damage point
- Other system load protective devices for the largest branch circuit and the largest feeder circuit breaker in each motor control center

Where possible, adequate time margins will be provided between device characteristics such that selective operation is provided, *while providing proper protection.*

Arc Flash Analysis Details

Background

NFPA 70E Standard, Article 110.7 (F), states that an electrical safety program shall identify a hazard/risk evaluation procedure to be used before work is started on or near live parts. Article 130.7 (A) states that employees working in areas where electrical hazards are present shall be provided with, and shall use, protective equipment that is designed and constructed for the specific part of the body to be protected and for the work to be performed.

Procedure

In accordance with NFPA 70E and IEEE 1584, commercially available software packages provide the calculation of incident energy and flash protection boundary. The equations used in these calculations are based on actual test values. These tests measured the calories per square centimeter (cal/cm^2) radiating from a simulated arcing fault. The measurements were performed at a theorized working distance of 18.00 inches (457.2 mm).

The intent of the NFPA 70E and IEEE 1584 guidelines is to establish standard calculations to determine an Approach Boundary and an associated PPE Hazard Level that will limit the injury to the onset of a second-degree burn to the face and the torso of the worker. An incident energy of $1.2 \text{ cal}/\text{cm}^2$ represents the onset of a second-degree burn. The various PPE Hazard Levels are described in the NFPA 70E standard on a scale of 0 to 4. An incident energy greater than $40 \text{ cal}/\text{cm}^2$ will be described in this study as "Dangerous" and no Hazard Level can be applied. Thus, no PPE is approved to protect

the worker from a potential arc flash hazard and the equipment enclosure should not be opened unless the equipment is de-energized, tagged-out and locked-out.

The arc flash analysis considers each medium and low voltage system location within the scope of the work. IEEE Std. 1584™-2002 states that equipment below 240V need not be considered unless it involves at least one 125 kVA or larger low-impedance transformer in its immediate power supply. Therefore, no detailed calculations will be performed for 120/208V locations supplied by a transformer smaller than 125 kVA, however, labels will be provided for these locations and will be labeled as hazard risk category zero. For the detailed calculations, the software determines the available fault currents for each location and the clearing time of the device protecting the same location. From these determinations, the potential incident energy is calculated for each location. Arc flash computations shall include both line and load side of main breaker calculations, where necessary.

Tabulations

The following tabulations will be provided as part of the study:

Input Data

- Short-circuit reactance of rotating machines
- Cable and conduit materials
- Bus ducts
- Transformers
- Reactors
- Aerial lines
- Circuit resistance and reactance values

Short-Circuit Data

- Source fault impedance and generator contributions
- X to R ratios
- Asymmetry factors
- Motor contributions
- Short-circuit kVA
- Symmetrical and asymmetrical fault currents

Recommended Protective Device Settings

- Phase and ground relays:
 - Current transformer ratio
 - Current setting
 - Time setting
 - Instantaneous setting
 - Specialty non-overcurrent device settings
 - Recommendations on improved relaying systems, if applicable
- Circuit breakers:
 - Adjustable pickups and time delays (long time, short time, ground)
 - Adjustable time-current characteristic
 - Adjustable instantaneous pickup

Arc Flash Results

- Arcing fault magnitude
- Device clearing time
- Duration of arc
- Arc flash boundary
- Working distance
- Incident energy
- Recommendations for new equipment and/or system changes to reduce the calculated arc flash energy level below $40 \text{ cal}/\text{cm}^2$ where possible

Submittals

The results of the short-circuit, coordination and arc flash study will be summarized in a final report.

The report will include the following sections:

- One-line diagram
- Descriptions, purpose, basis and scope of the study

- Tabulations of circuit breaker, fuse and other protective device ratings versus calculated short-circuit duties
- Protective device time versus current coordination curves, tabulations of relay and circuit breaker trip unit settings, fuse selection
- Fault current calculations including a definition of terms and guide for interpretation of the computer printout
- Arc flash analysis calculations including a definition of terms and guide for interpretation of calculated values
- Recommendations for system improvements, where needed
- Executive summary

In addition to the report, EESS can provide field services (at additional cost) to:

- Adjust relay and protective device settings according to the recommended settings table provided by the coordination study. Field adjustments to be completed by the engineering service division of the equipment manufacturer under the startup and acceptance testing contract portion
- Make minor modifications to equipment as required to accomplish conformance with the short-circuit and protective device coordination studies
- Notify owner in writing of any required major equipment modifications
- Provide arc flash solution engineering and recommendations to lower the incident energy at specific locations where the hazard is unacceptable

Contents

<i>Description</i>	<i>Page</i>
Arc Flash, Short-Circuit and Coordination Studies . . .	V3-T10-12
Load Flow/Power Factor Correction Study	
Harmonic Analysis Study	V3-T10-17
Advanced Analysis and Design Services	V3-T10-19

Load Flow/Power Factor Correction Study

General Description

Background

The primary function of the electrical power distribution system is to provide real and reactive powers demanded by the various loads connected to the system. Simultaneously, the frequency and various bus voltages must be kept within specified tolerances, even though the load demands may undergo large and unpredictable changes.

The Load Flow Study is an analysis of the system capability to supply the connected load under steady-state conditions. Optimal management of the power system can be achieved through the use of this analytical tool. Necessary in the planning or expansion of electrical power systems, a load flow study demonstrates the distribution of power and voltage levels throughout the system for selected operating scenarios. These scenarios may include normal and emergency operating modes, present and future circuit arrangements, and alternative designs and equipment components.

Study results include real (kW) and reactive (kVAR) power flow through transformers and cables, voltage levels at system buses, power factor and system losses. These values allow the power system engineer to identify overloaded transformers and cables, provide recommendations for proper transformer tap settings, and determine the need for power factor correction capacitors.

The Load Flow Study is a prerequisite to developing optimum generating strategies and systems controls.

Study Procedure

Investigate the system loading conditions for the normal and contingent operating conditions. All system loads (kW and kVAR components) and power sources are included in the analysis.

The study is processed using state-of-the-art software, which utilizes an iterative technique to calculate real and reactive power flows, and bus voltage levels throughout the system.

The data base for the load flow analysis is established from existing design or nameplate load data or by monitoring the existing feeders with a digital power monitor. Each feeder is monitored for a minimum of two hours, during typical operating periods. The following system data is utilized as input to the load flow program:

- Current and voltage
- kW, kVAR and kVA
- Power factor

The study for the electrical system is based on both present and future loading considerations and switching configurations. A maximum of three load flow study cases are performed to analyze power flow, voltage regulation, power factor, transformer tap settings and other load considerations.

An evaluation of the existing utility billing contract will determine whether power factor correction should be incorporated in the power system. If power factor correction is needed, the appropriate hardware is recommended and located to maintain desired power factor at the metering point. The study also indicates any switching of power factor correction equipment that may be necessary to maintain proper voltage levels.

If the study results indicate that power factor correction equipment is necessary, the approximate payback period will be calculated for equipment purchase and installation.

Results

The Load Flow Study includes the following for each circuit condition analyzed:

- Bus voltages, line currents, power factor and transformer loading in actual quantities and in percent of the device base values
- Recommended transformer tap settings
- Recommended generator dispatch schedules
- Complete set of capacitor recommendations, including calculated payback period based upon energy savings, if additional shunt compensation is required for power factor improvement or voltage support
- Recommended equipment upgrades or circuit reconfigurations to optimize the power flow from the source to the loads

Data Requirements

In addition to the data required for the short-circuit study, the following data is required to complete the load flow study:

- Design, nameplate or measured load data
- Ratings and connections of all power factor correction capacitors
- Reactor impedance and ratings
- Power flow measurements (when available) at utilization transformers

Harmonic Analysis Study



Contents

<i>Description</i>	<i>Page</i>
Arc Flash, Short-Circuit and Coordination Studies	V3-T10-12
Load Flow/Power Factor Correction Study	V3-T10-15
Harmonic Analysis Study	
Advanced Analysis and Design Services	V3-T10-19

Harmonic Analysis Study

General Description

Background

The operation of nonlinear loads and in particular variable frequency drives (VFDs) in a power distribution system creates harmonic currents that flow throughout the power system. When considering VFDs, the frequencies and magnitudes of the harmonic currents are functions of the number of drive rectifier pulses, as well as the AC system impedances. Harmonic voltages result from the harmonic current flowing back into the harmonic impedances of the distribution system. The order of the harmonic currents generated is $np \pm 1$, where n is any integer and p is the number of drive pulses. Therefore, for 6-pulse drive, the order of harmonics is 5th, 7th, 11th, 13th, 17th, 19th, etc. For 12-pulse drive, the order of harmonics is 11th, 13th, 23rd, 25th, 35th, 37th, etc.

Harmonic studies can provide calculation of the current and voltage harmonics throughout the electrical distribution system when the generated harmonic current magnitudes and the system 60 Hz impedances are known.

Significant harmonic current and voltage magnitudes can have adverse effects on system components and overall system operation. Harmonic currents cause increased power losses in transformers, motors and cables. The higher power losses increase equipment-operating temperatures, increasing the possibility of overload, increasing thermal stress on insulation, and reducing overall system efficiency.

Power factor correction capacitor banks are particularly vulnerable to the detrimental effects of power system harmonics. Most capacitors are designed to operate at a maximum of 110% of rated voltage and 135% of rated kVAR. Large magnitudes of voltage and current harmonics can exceed these design limits, and cause severe capacitor bank damage. Since capacitive reactance is inversely proportional to frequency, capacitor banks act as sinks for current harmonics in the system. This often causes capacitor fuses to open or capacitor damage when fuses are not present or improperly sized.

A serious condition, with potential for substantial damage, occurs as a result of harmonic parallel resonance. As frequency increases, capacitive reactance decreases and inductive reactance increases. Harmonic resonance occurs at the frequency when the inductive reactance of the source-side circuit equals the capacitive reactance of the power factor correction capacitor. Looking back into the circuit from the harmonic source, the capacitor is in parallel with the substation transformer. The circuit total impedance (including the capacitor) is very high at the resonance frequency. If the VFDs generate harmonic current at the resonance frequency, large harmonic voltages will be developed at the capacitor and transformer bus, and serious equipment damage can occur.

IEEE Std. 519-1992 establishes recommended limits for harmonic voltages and currents in power systems.

Study Procedure

Harmonic analysis of the electrical distribution system for the circuit conditions listed below.

- Existing system configuration
- System with new VFDs or other nonlinear harmonic creating loads in operation

The power system is modeled for the fundamental frequency and appropriate harmonic frequencies.

System impedances are calculated for the fundamental frequency as well as for each appropriate harmonic frequency.

The following is calculated for each study:

- System harmonic voltages in rms and % THD
- System harmonic currents in rms and % THD
- An IEEE 519 analysis at the point of common coupling with incoming utility
- Capacitor bank evaluations on the basis of voltage, current and kVA
- The payback period of the total cost (filter equipment, installation and/or relocation) for the three most feasible filter options

In addition, the drive's harmonic generation based upon the drive's loading and characteristics is calculated. If specified, field measurement of the VFD current harmonic generation during the process operation can be made. Each harmonic component is then successively injected into the simulated system, and the resulting harmonic currents and voltages are computed throughout the system.

If the calculated magnitudes of harmonic voltages and/or currents are excessive, the optimal corrective solution will be determined to reduce the harmonic quantities to within acceptable limits.

When a harmonic filter is recommended, a complete equipment specification will be provided. A final study case is conducted to verify that the harmonic filtering equipment will reduce harmonic levels to within acceptable standards.

Results

At the conclusion of the Harmonic Analysis, the following will be submitted for each circuit condition analyzed:

- Description, purpose, basis and scope of the harmonic study and a single-line diagram of the portion of the power system that is included within the scope of the study
- Tables listing the individual harmonic voltages and currents and total harmonic distortions (THDs) for all major buses within the electrical distribution system. Waveforms for all of the calculated harmonic voltages and currents will be displayed
- Plots of frequency versus impedance (harmonic resonance scans) for all shunt capacitor locations
- Complete recommendations for harmonic filters, shunt capacitors and series reactors, required for harmonic suppression
- All computer output and an interpretation guide

Data Requirements

In addition to the data required for a load flow analysis, the following data is also required:

- Complete text report of each measurement location sorted by voltage and current, and listing the individual harmonic component and the total harmonic distortion (THD)
- Waveforms of each measurement sample
- Detailed harmonic spectrums of the harmonic generating loads

Contents

<i>Description</i>	<i>Page</i>
Arc Flash, Short-Circuit and Coordination Studies	V3-T10-12
Load Flow/Power Factor Correction Study	V3-T10-15
Harmonic Analysis Study	V3-T10-17
Advanced Analysis and Design Services	
Transient Stability	V3-T10-19
Switching Transient Analysis	V3-T10-20
Transient Motor Starting Analysis	V3-T10-21
Ground Grid Analysis	V3-T10-21
Electrical Design Services	V3-T10-22

Advanced Analysis and Design Services

Transient Stability

Background

Power system stability is a condition where the various synchronous machines of a system remain in synchronism, or in step, with one another. Instability is the condition when one or more of the machines fall out of step.

With a sudden increment in load, there is a definite upper limit to the load that a machine will carry without pulling out of step. This is defined as the transient stability limit of the system for the given condition.

The transient stability limit may have different values for the same system, depending upon the nature and magnitude of the disturbance. Disturbance types include a sudden increase in load, by the disconnection of a parallel line or disconnection of the utility source. The most severe disturbance subjected to the electrical distribution system is a short circuit.

All transient stability studies should include computer simulations that determine the effects of short circuits upon the system transient stability.

Study Procedure

The Transient Stability Study provides an analysis of the transient response of the system and rotating machines following system disturbances, and the behavior of the system in relation to the power company tie.

Data from the study can be used to determine the effect of generator and/or motor performance, system voltage and frequency, all as a function of time. Generator and motor performance are affected by:

- Abrupt changes in load and including the starting and accelerating effect of large motors
- Short Circuits, from which effect the critical operating time for protective relays can be determined
- Partial loss of generation or loss of power company tie, and the corrective effect of a load shedding scheme

Study engineers will analyze system disturbance scenarios using state-of-the-art software. Protective device fault clearing times will be included in the computer simulations and the generator, motor, and tie-line protection and coordination will be evaluated from a system stability perspective.

Load-shedding schemes will be evaluated or developed, based upon the operating requirements of the customer facility.

Results

At the conclusion of the Transient Stability Analysis, Eaton will submit the following:

- Machine variables, including turbine input and generator output power, accelerating power, frequency deviation, rotor angle, field voltage and current, terminal voltage magnitude and angle, and generator current

and angle. These are summarized for each machine in time increments over the nominal transient time interval of one or two seconds. For the load shedding study analysis, the time interval would be extended to five seconds or longer

- Plotted swing curves of power angle over the transient time period for each machine
- The magnitude and angle of voltage and frequency deviation for any bus in the system
- Summary of line currents, power flows and apparent impedance on any line
- If required, details of the load shedding scheme, including the sequence of load separation, critical clearing time and type of relay

Switching Transient Analysis

Background

A transient is initiated whenever there is a sudden change of circuit conditions. This most often occurs when a switching operation occurs, such as capacitor switching, transformer energizing and fault current interruption. Some of the most severe and damaging transients are produced by lightning strikes. Voltage transients will result when loads on an electrical distribution system are switched. Industrial and commercial power systems comprise capacitive and inductive components. The transient disturbance occurs because the currents and voltages do not reach their final value instantaneously.

The severity of a voltage transient is a function of the relative power level of the load being switched, and the available fault current magnitude in the supply circuit where the switching takes place. Some circuit components such as motors and transformers are adversely affected by the speed (frequency) of the voltage transient as well as its magnitude. Voltage transient magnitudes should not exceed twice the system voltage when they occur from normal switching operations. Properly rated equipment BIL provides adequate transient or surge protection for these instances.

Complex voltage transients result from abnormal switching operations and current chopping, prestrikes and restrikes cause these disturbances. Voltage magnitudes may approach ten times the system voltage and must be controlled by surge arresters, surge capacitors and/or resistors. These surges can damage the most rugged system components.

Study Procedure

Eaton engineers will discuss with customer personnel all aspects of the disturbance that is being investigated. The circuit configuration and system loading prior to the disturbance and any subsequent equipment damage incurred will be examined.

Engineers will develop a computer model of the electrical circuit with EMTP, Electromagnetic Transients Program. All circuit components, including surge capacitors, equipment capacitance, bushing capacitance, CT and PT capacitance, and transformer saturation characteristics will be modeled in detail.

The suspect switching operations, including all reasonable perturbations such as current chopping, circuit breaker restrike and prestrike, will be simulated with the computer. Voltage and current transient magnitudes will be calculated, and the waveforms will be displayed for all of the transients caused by the switching operation.

If excessive transient voltages or currents are observed, the study engineer will propose corrective measures, which may include surge protection, damping resistors or modified switching procedures. These measures will be analyzed with additional simulations to ensure that excessive switching transients are avoided or reduced to acceptable levels.

Finally, an insulation coordination study, which compares surge arrester ratings with equipment BIL, will be completed to confirm the recommended surge protection system for the circuit being investigated.

Results

At the conclusion of the Switching Transient Analysis, Eaton will submit the following:

- Detailed description of the sequence of events that preceded the switching transient that disrupted the electrical system operation and caused equipment damage
- Magnitudes and waveforms of transient voltages and currents calculated by the computer simulations
- Recommendations for surge protection, such as surge arresters, surge capacitors, RC suppression, damping resistors or TVSSs, for all affected equipment
- Results of the insulation coordination study to evaluate the degree of protection afforded by the recommended surge protection system
- Appendix, including one-line diagrams, computer program output sheets and all other pertinent supporting documentation

Transient Motor Starting Analysis

Background

A motor starting study is conducted to evaluate the motor's impact on the power system and the power system's impact on the motor. Motor starting studies are usually performed for new motor installations to ensure system reliability, provide data for motor protection, and to identify any system modifications that may be necessary to avoid starting problems.

Starting a large motor on a distribution grid with limited capacity may cause severe voltage reduction and not produce enough motor torque to accelerate the motor. One of the most noticeable effects is light flicker during motor starting. Voltage dips may cause problems with voltage sensitive electronic equipment to such as computers and microprocessors.

The study will recommend solutions to any problem discovered. One possible solution may be to install a reduced voltage starter to decrease the motor inrush current and minimize the voltage drop. A system balance must be maintained to minimize impact on the system and allow sufficient motor torque to perform its function.

Eaton will investigate various methods for minimizing system disturbances when starting of motors. These methods include:

- Reduced voltage starting methods such as: auto-transformer, reactor, wye-delta, primary resistor, part winding and solid state
- System modifications, including paralleling circuits, addition of shunt capacitors, adjusting transformer taps and relocating loads

Study Procedure

A Motor Starting Study will determine the system effects of starting and accelerating the motor and associated load from time zero to full speed. The study will calculate the terminal voltages of the motor and other buses when the motor and load is started.

Eaton will develop the circuit model on the digital computer. The procedure requires a Load Flow analysis to be completed initially to determine system conditions prior to motor starting.

Computer simulations of various motor starting methods, motor starting sequences and circuit configurations will follow. From these results, Eaton will recommend the best means of starting motors at that circuit location.

Results

At the conclusion of the Motor Starting Study, Eaton will submit the following for each method analyzed:

- Tables listing voltages at the motor terminals and at other significant locations within the electrical distribution system
- Plots of motor speed, motor torque, load torque, accelerating torque, accelerating time, power factor, and voltages at the motor terminals and other significant locations in the system
- Recommendations of various options to correct any problems found in starting and accelerating the motor and load

Ground Grid Analysis

Background

A Ground Grid Analysis ensures that the ground grid design provides adequate safety for personnel during ground fault conditions. When fault current flows through the earth from the ground grid of the plant substation, the potential of the plant substation ground is elevated. Voltage potentials along the ground surface may be severe enough to endanger a person walking on the surface, and dangerous potential differences may exist between grounded apparatus, structures, fences and nearby earth.

Study Procedure

Eaton engineers will evaluate your switchyard or substation ground grid to ensure that the performance of the grid adheres to IEEE Standard 80, "Guide for Safety in AC Substation Grounding."

This will involve utilizing a computer software program that models the ground grid under fault conditions. All voltages at the surface are calculated, allowing evaluation of Step and Touch potentials, to ensure the safety of plant personnel. The Ground Potential Rise is also calculated to evaluate the potential of damage to interconnected equipment. The following services are available and are an integral part of doing a complete evaluation:

- Inspection and evaluation of existing grid conductors and connectors and continuity
- Soil resistive measurements and interpretation
- Measurement of ground grid impedance
- Safety assessments—step and touch voltage criteria

- Substation ground grid layout design, ground grid equipment specifications, bills-of-materials, requirements to meet IEEE Std. 80
- Recommendations for improving existing grids

Results

At the conclusion of the Ground Grid Analysis, Eaton will submit the following:

- Executive summary, including findings and recommendations
- Study procedures
- Calculation results, including GPR and Step and Touch Potentials
- Data summary, including computer report output
- Appendix, including one-line diagrams, computer program output sheets, and all other pertinent supporting documentation

Electrical Design Services

Eaton's electrical design services can extend from the point of utility connect to the equipment. Design services are integrated with analysis services, resulting in a complete engineered solution. The level of design detail can be customized from minimal design consultation and advice to a complete design package with specifications and drawings.

Typical design services include:

- Distribution System Design—Design and specification of the electrical distribution system from the point of utility interconnection to the downstream utilization equipment
- Substation Design—Complete substation design service is available, including ground grid analysis and design, substation layout, equipment specification, protection and control
- Protection and Control—Design of advanced electrical protection and control, including transmission line protection, system automation and advanced metering
- Renewable energy design, including the AC and DC distribution systems, collector substation and utility interconnection design

Typical construction drawings and documentation for design projects include:

- Demolition plans for the existing equipment and building (if applicable)
- New proposed switchgear arrangement plans and elevation views
- Specifications for all new AC and DC distribution equipment
- All necessary engineering calculations (load flow, short-circuit, etc.)
- Single line diagrams for the AC and DC distribution and auxiliary equipment
- Arrangement plans and details for new structures, bus systems, auxiliary and DC equipment
- Conduit raceway drawings and schedules
- Control panel and terminal board panel design drawings
- Lighting and grounding modifications for the new installation
- Building modification for garage doors, air ventilation, etc.

Field Engineering Services



Contents

Description

Field Engineering Services

Selection Guide

The following tables present the relationship between Eaton’s Electrical Sector capabilities and the user’s needs:

Consulting and Turnkey Project Management

Engineering Services Capabilities	New Construction and Facility Growth	Improved Reliability and Reduced Downtime	Life Extension and Cost Reductions
New substation design, management and construction	Support consultant or end-user by offering one-stop shopping and an exclusive 2-year warranty on all Eaton products supplied.	—	Design and construction costs are reduced by a single-source contract. In addition, end-user internal engineering resources can be applied to core-business process improvements, rather than the electrical distribution system.
Electrical, mechanical and instrumentation services	Through networking the experiences of our many service locations, we can add mechanical and instrumentation services to our construction capabilities.	—	
Power system studies Short circuit Device evaluation Coordination Load flow Power factor Harmonics Power quality Grounding Reliability Switching transient Others	New construction requires the proper set of power system studies. We can review your current and future power needs: reliability, loading profiles, emergency power requirements, etc., and determine the necessary studies.	A short-circuit study is required for protection of personnel and equipment. In addition, coordination studies reduce downtime by limiting the power loss to only the faulted feeder. Power quality studies are necessary due to the many new nonlinear loads and their potential effect on critical equipment.	Extending the life of an electrical distribution system should include an updated single-line diagram and the proper complement of Power System Studies to address your current and future needs.
Failure/root-cause analysis	—	Electrical outages can result in extensive downtime and loss production. Critical systems should be investigated to determine the cause of such outages, and corrective actions planned and implemented.	An investigation of critical outages can result in long-range cost reductions by preventing the repeat of such occurrences, and allowing system improvements while funding is available.
Equipment relocation	Changing production needs can be satisfied by the relocation of power distribution components, either by use of internal or sister-plant equipment.	—	Costs can be reduced for new production projects by the allocation of existing equipment, thereby eliminating the need for new purchases.

System Integration

Engineering Services Capabilities	New Construction and Facility Growth	Improved Reliability and Reduced Downtime	Life Extension and Cost Reductions
Plant monitoring, protection and control Digitrip PowerNet Advantage starters DeviceNet PLC interface	Plant-wide electrical power distribution system monitoring and control can be cost-effectively implemented during new construction. New Eaton electrical products allow for communications through all levels of the power distribution network. Eaton's PowerNet system allows for plant-wide monitoring and control from a single workstation or from any number of workstations connected to a plant LAN, company, intranet or Internet.	Real-time monitoring, and remote control of circuit breakers can greatly improve reliability by providing immediate indication of a problem, allowing for a quick resolution; and if necessary, remote control of power distribution equipment.	Plant electrical distribution systems are being subjected to higher loads, and greater harmonics. Plant-wide monitoring can help identify these areas of rapid deterioration, and implement corrective actions to extend the life of the electrical system. Taking such action will also prevent costly outages and the resultant downtime. In addition, with the advent of utility deregulation, having accurate power usage values will allow for improved negotiating on power purchases.
PLC/PC control and open automation systems	New process and discrete control systems currently employ PLCs for control and monitoring. Eaton PC control and open automation products can be applied for many of these systems with full integration into plant-wide control and information management systems. Integration to other OEM's equipment is also available.	The real-time, self-diagnostic information available with a PC control/open automation system significantly reduces system downtime by allowing the operator to proactively respond to system problems before a shutdown occurs.	PC control/open automation systems provide the greatest level of flexibility when implementing a control system. The open automation concept allows the user to select the "best in class" components without being tied to a single OEM. PC control systems can provide a wealth of information that can be easily integrated into manufacturing and enterprise systems allowing the user to optimize process efficiency.
Drive systems motor control	Eaton drive systems, as well as modernized motor control, provide critical hardware for new efficient process system construction.	Modern drive systems and motor control will greatly improve system reliability by the application of new technology, and allowing for plant-wide communications and control.	The electrical portion of the process-line can have extended life, and develop a lower cost of production. This can be combined with the life extension of the mechanical components.
Energy management load shedding	Eaton maintains application expertise and a full line of products to support energy management systems. Our energy management experts can design and implement an energy management program including financial analysis and justification.	—	With the advent of utility deregulation, in-house power generation and load shedding capabilities can aid your negotiations for reduced electric rates. In-house generation voltage regulation and excitation systems can also add to system life.
Generator/emergency power systems	New power reliability needs may require modern emergency power systems.	Reliability can be improved for critical processes with improved standby power systems.	

10

Training

Engineering Services Capabilities	New Construction and Facility Growth	Improved Reliability and Reduced Downtime	Life Extension and Cost Reductions
New product training Electrical power equipment Drive systems PLC systems	Training is offered on all new products supplied by Eaton's Electrical Sector. The construction phase is a beneficial time to incorporate training, from equipment and a funding standpoint.	—	—
Distribution systems analysis training	—	Plant engineers require an understanding of the dynamics of electrical power distribution systems. This training addresses topics to improve existing electrical systems, as well as plan for future expansions.	Life extension of the power distribution system requires a proper analysis by the plant electrical engineer. Appropriate investigations can be completed and recommendations planned for implementation.
Power quality and grounding training	—	Power quality and grounding issues are affecting new sensitive process equipment. This training can provide short- and long-term solutions, as well as recommending methods to accurately measure power quality.	—
Electrical equipment maintenance training	—	Completing proper and timely maintenance on electrical equipment will improve reliability and reduce downtime. This training shall identify simple, yet effective, maintenance tasks, which can be completed by plant personnel.	Proper equipment maintenance will result in system life extension, indirectly by reducing failures. In addition, training in-house personnel to complete several maintenance duties can reduce costs.
Customized training Scheduled On-site	In conjunction with new construction, training can also be integrated to include existing electrical components, regardless of manufacturer. This allows for effective one-time training, on-site if desired, and incorporated into the construction project. A site review would be conducted to identify the training needs, and associated equipment.	A plant-wide custom training program can address specific reliability needs, as well as goals for reduced downtime.	Cost reductions can be achieved by providing maintenance training to operation personnel, thereby possibly combining operating and maintenance duties. This training will also provide operators with a better understanding of the needs of electrical equipment, thereby resulting in life extension through reduced fatigue.

Startup and Commissioning

Engineering Services Capabilities	New Construction and Facility Growth	Improved Reliability and Reduced Downtime	Life Extension and Cost Reductions
Installation support and supervision	Electrical construction of sophisticated power distribution equipment requires support and/or supervision by factory trained personnel.	Proper installation techniques have been proven to reduce short-term operation problems and the resultant downtime.	Proper installation will result in an extended life, through the proper application of stress and tensions on various electrical components.
Acceptance testing Electrical power equipment: Switchgear Outdoor units Circuit breakers PowerNet, etc. Starters Motor control Transformers Tap changers Network protection Drive systems PLC systems Nuclear safety related 1E	Startup testing should be completed by an independent division of a major electrical equipment manufacturer. Eaton provides an exclusive 2-year warranty on all Cutler-Hammer brand products supplied, when EESS completes engineering studies, startup and acceptance testing.	Proper acceptance testing provides baseline data for future maintenance. This allows the development of predictive maintenance programs, thereby anticipating outages, and identifying correction actions. EESS offers comprehensive ongoing predictive and preventive maintenance programs.	Proper acceptance testing will identify any areas requiring corrective action, thereby resulting in a system with the longest life expectancy.
Startup, training and warranty support	Trained individuals should complete equipment startup. Voltage levels, phasing and proper grounding requires attention to ensure a safe startup. Specific equipment testing and adjustments are also necessary to ensure all electrical safety interlocks are operational and ready for long-term service. Training can be provided immediately following, or during the startup process. Warranty issues can be quickly identified and corrected by factory trained personnel.	Long-term reliability is ensured by the proper startup, training and warranty support, all of which are provided by EESS.	Allowing the training cycle to commence immediately following, or during, the startup of the equipment can reduce training costs. Travel and setup costs are minimized, and plant personnel witness the operation of all associated electrical equipment, as part of the training session.
Exclusive 2-year warranty	Eaton has identified that warranty-related costs may be associated with improper startup and acceptance testing by groups that are not factory trained. This results in construction delays, as well as possible long-term reliability issues. Eaton offers an exclusive 2-year warranty on Cutler-Hammer brand products, when all engineering studies, startup and acceptance testing is completed by EESS.		Startup costs are reduced by allowing EESS to complete all functions since the required OEM presence for equipment installation support can be incorporated into the acceptance testing.

Predictive and Preventive Maintenance

Engineering Services Capabilities	New Construction and Facility Growth	Improved Reliability and Reduced Downtime	Life Extension and Cost Reductions
PM program design and implementation Electrical power equipment: Switchgear Outdoor units Circuit breakers PowerNet, etc. Starters Motor control Transformers Tap changers Network protection Medium voltage generators Medium voltage motors Drive systems PLC systems Nuclear safety related 1E equipment	Following construction, EESS can develop a long-term predictive/preventive maintenance program. This allows for recording of the necessary baseline data required for effective predictive maintenance programs. Partial discharge sensors installed in new medium voltage switchgear provide years of predictive diagnostics.	Predictive maintenance involves identifying measurable parameters, which when trended, provide an indication of the reliability and the life expectancy of the subject equipment. Preventive maintenance includes specific maintenance tasks that extend the useful life of the subject equipment. A comprehensive program can be developed, whereby plant personnel complete portions, supplemented by EESS personnel. Plant personnel would perform observations, minor maintenance and data recording. Tasks would be developed to complement plant personnel's existing daily duties. Periodic reports would be issued addressing all trends. Immediate corrective actions would be identified, as well as long-term predictive maintenance requirements. Reliability is improved and downtime reduced by the proper and regular implementation of predictive and preventive maintenance programs.	A properly designed program will take advantage of in-house personnel, thereby providing a cost-effective plan. Program implementation and required corrective actions will result in the longest life expectancy possible. EESS can provide a complete short- and long-range PM program to satisfy your life extension and cost reduction needs. Partial discharge detection identifies insulation deterioration prior to permanent damage and ultimate failure. Efficient outage correction actions can be implemented.

Electrical System Modernization

Engineering Services Capabilities	New Construction and Facility Growth	Improved Reliability and Reduced Downtime	Life Extension and Cost Reductions
Switchgear bus MVA upgrading	Existing switchgear and bus duct can be retrofitted with partial discharge sensors, therefore allowing for online predictive diagnostics.	With possibly greater utility fault currents, new in-house cogeneration and additional motor loads available, existing bus MVA ratings may be exceeded. Engineering inspection, testing and analysis are employed by experienced engineers to determine corrective measures to improve bus MVA ratings. Life extension is achieved for the entire switchgear lineup when combined with breaker MVA upgrading by vacuum replacements.	
Bus insulation systems	Existing switchgear and bus duct can be retrofitted with partial discharge sensors, therefore allowing for online predictive diagnostics.	Replacement fluidized insulated bus systems are supplied to improve the reliability and extend the life expectancy of the switchgear bus system. During the preliminary inspection, the sources of bus contamination, or environmental factors, are reviewed and long-term system corrections are also implemented.	
Medium voltage vacuum retrofit and low voltage Digitrip RMS retrofits	—	As presented in <i>Circuit Breaker Specialized Services</i> , medium voltage vacuum replacements improve the reliability and life expectancy of medium voltage breakers; as well as low voltage Digitrip RMS retrofits do the same for low voltage breakers.	
Low and medium voltage motor starting upgrades	—	Eaton's Cutler-Hammer aftermarket products include AMPGARD® retrofit kits with air to vacuum replacements. In addition, for low voltage motor control and DS switchgear, replacement units are manufactured as direct replacements for Westinghouse and other OEM's MCC buckets. Reliability is improved by the replacement of the operating coils and associated contact assemblies.	Life extension is achieved for medium and low voltage motor control centers by replacing the worn components with new production units. In addition, improved motor protection and communications can be incorporated into the upgrade package.
Low and medium voltage cell retrofit	—	To assist in improving reliability of individual feeder cubicles, Eaton can supply a complete circuit breaker and supporting cell for installation into existing switchgear. The result is a new production unit, custom installed into an existing older vintage switchgear lineup. A site inspection is required to determine the best breaker/cell combination to satisfy the system requirement.	Costs are reduced in comparison to modernizing the entire switchgear lineup. Life extension is achieved for a single cubicle feeder only.
Molded case circuit breaker upgrades	—	Older style molded case breakers can be replaced with new Eaton standard or the high interrupting Series C® class of molded case breakers. Long-term reliability is improved.	Life extension is achieved for the entire lineup by application of new production units into the existing switchboard lineup.
Plant monitoring, protection and control Digitrip PowerNet Advantage starters DeviceNet PLC interface	—	Real-time monitoring and remote control of circuit breakers can greatly improve reliability by providing immediate indication of a problem, allowing for a quick resolution; and if necessary, remote control of power distribution equipment.	Plant electrical system life extension can be achieved by improving the monitoring, protection and control of the individual components in a planned and unified manner. Plant electrical distribution systems are being subjected to higher loads and greater harmonics. Plantwide monitoring can help identify these areas of rapid deterioration, and implement corrective actions to extend the life of the electrical system. In addition, with the advent of utility deregulation, having accurate power usage values will allow for improved negotiating on power purchases.
Power factor control and correction	—	—	Utility rates, as well as internal electrical system losses, are related to power factor. Cost reductions are achieved through proper power factor control and correction. For systems with harmonics, filtered power factor capacitor banks should be designed and installed.
Ground fault detection systems	—	Improved system reliability and personnel safety are achieved by a properly applied ground fault detection system. Systems can be applied at MV, or low voltage levels by the use of Eaton products.	Costly outages, and faults related to repeated arcing grounds, can be eliminated, as well as providing an improved environment for personnel safety.
High resistance grounding and detection	—	High resistance grounding systems can be installed on ungrounded systems. These systems will limit the ground fault current, thereby reducing ground fault damage. The advantages of an ungrounded system are maintained with the added feature of ground detection and correction while maintaining system operation.	Costs are reduced by limiting the damaging effects of ground fault current and reducing the troubleshooting time to locate grounds. Ground fault pulsing allows for locating the ground, with portable hand-held sensing devices, during online operation.
Surge/lightning protection systems	—	Outages can be prevented, related to surges or lightning by the proper application of protective devices.	Costly equipment damage can be eliminated.
Automatic transfer scheme upgrades	—	Older automatic transfer schemes employ old relay systems. The relay coils may be at the end of their useful life, and operation can not be assured for the next required automatic transfer. Unfortunately, most defective transfer schemes are not detected until a failed operation has occurred.	Cost reductions related to downtime are eliminated, by a review and upgrade of older transfer schemes, before the first failed automatic transfer operation occurs.

Electrical System Modernization, continued

Engineering Services Capabilities	New Construction and Facility Growth	Improved Reliability and Reduced Downtime	Life Extension and Cost Reductions
Network protector service/relaying systems	—	Network protector relaying systems require service and testing to ensure continued proper operation. Older relaying systems can be upgraded, and complete network protector service is available to improve reliability.	Life extension is achieved by proper servicing, and/or upgrading of network protector components. Complete network protector reconditioning is also available from Eaton.
Generator voltage regulation and static excitation systems	—	Many older in-house cogeneration units have antiquated voltage regulation and excitation systems. These older systems can not function with the precision of modern replacements, and often require extensive maintenance. Eaton offers a complete range of products to apply to these older systems, thereby improving overall system reliability and reducing downtime.	With the advent of utility deregulation, in-house cogeneration has become a critical source of supplemental electrical power, for peak-shaving and negotiating competitive power usage rates. With the associated maintenance of the mechanical and rotating components, the life expectancy can be extended with the inclusion of a modern electrical control system.
Reduced voltage and soft starters	—	Application of current production starters will improve reliability due to the new components installed.	Starter retrofits can be easily justified based on energy cost savings, and reduced wear-and-tear on the process line during starting.
Synchronous motor field application	—	Many older synchronous motors employ field application panels that are obsolete, with parts support no longer available. Applying a new Eaton field application package will improve reliability and reduce future downtime.	Life extension can be achieved for the synchronous motor field application system by applying new Eaton products.
Drive systems PLC process systems	—	Retrofitting older drive and relay-logic process systems with new drives and PLCs provides for greater reliability and reduced downtime. Older devices are eliminated, thereby eliminating nuisance control problems.	Process cost reductions will be realized by drive system PLC improvements due to greater control of production parameters. Eaton sensors, in conjunction with drive and PLCs, can provide a complete modernized production system.
All OEMs upgraded Westinghouse/GE/ITE BBC/ABB/Square D Allis Chalmers/Siemens/ Federal Pacific/Roller Smith	—	Field personnel are experienced in Eaton equipment, as well as other manufacturer's equipment. This cross-OEM experience allows the application of singular new products to satisfy many OEM upgrading needs and provide uniformity across the various OEM's equipment.	

Circuit Breaker Specialized Services

Engineering Services Capabilities	New Construction and Facility Growth	Improved Reliability and Reduced Downtime	Life Extension and Cost Reductions
Low and medium voltage replacement circuit breakers	Spare cubicles, part of new construction with a planned expansion, can be equipped with low voltage and medium voltage replacement breakers. Eaton circuit breakers and other OEM circuit breakers can be supplied.	Downtime can be substantially reduced by allowing our Aftermarket Centers of Excellence to provide spare replacement breakers.	Aging circuit breakers can be replaced with direct roll-in replacements, thereby extending the life of the entire switchgear assembly.
AR-Series low voltage replacement breakers Westinghouse Allis-Chalmers Federal Pacific and others	—	Eaton's AR-Series low voltage replacement breakers provide a solution tailored to meet safety and reliability concerns while eliminating the need for new switchgear. AR-Series breakers are 100% new and are designed to be electrical and mechanical equivalents of the vintage breakers they replace. They are not "retrofits" and do not reuse any parts from the original breaker. The same safety, reliability and maintainability of new switchgear are obtained for a fraction of the total installed cost.	Life extension is achieved by upgrading existing breakers to the most current breaker technology. The AR-Series solution will result in a number of reduced costs associated with maintaining or replacing vintage equipment. These cost reductions include: reduced maintenance time, decreased outages due to readily available parts, elimination of field engineering costs, reduced spare parts investment increase safety.
Low voltage retrofits Digitrip RMS kits Westinghouse Cutler-Hammer GE ITE/BBC/ABB Allis-Chalmers Siemens Federal Pacific Square D Roller Smith	—	Eaton Digitrip RMS kits have been widely used to modernized low voltage circuit breakers. They offer advanced RMS sensing, digital display of current, improved protection, fault indication, self-testing and communications to Eaton's PowerNet system. Retrofits greatly improve reliability by applying the latest technology to existing circuit breakers.	Life extension is achieved by upgrading the critical trip system on low voltage circuit breakers. In addition, future testing costs are reduced, and in-house testing can be applied by the purchase of a portable test set.
Medium voltage vacuum roll-in circuit breakers Eaton new production breaker element Full ANSI design testing Increased MVA ratings available Field installation and startup	—	Older air circuit breaker contacts, arc chutes, mechanisms, secondary disconnects, etc., are replaced with current production vacuum breakers, incorporating all of the above into a single, fully ANSI tested device. Long-term reliability is improved.	Life extension of medium voltage switchgear assemblies can be accomplished by the replacement of existing air circuit breakers with new vacuum breakers. Eaton's Electrical Sector manufactures widely used vacuum breaker elements for this purpose.
Low and medium voltage recondition Aftermarket centers of excellence (ACE)	—	All components are refurbished, or replaced, depending on the extent of service contracted. Spares are available for interchanging units during scheduled outages, resulting in long-term reliability gains without costly unexpected outages.	The low and medium voltage breaker life is substantially extended. In addition, the service can include the application of modernized rms sensing trip systems. Specialized Navy, or Nuclear Safety Related 1E units are also serviced.
MCC motor starter buckets	—	Replacements provide all new components and added reliability.	Spares are available to provide extended life, during schedule outages.
MCC replacement buckets for other manufacturers	Add buckets or increase starter sizes in existing equipment.	Replacement units are newly manufactured including stabs and all breaker and control components. They utilize state-of-the-art technology increasingly reliability and uptime.	Many designs of vintage MCC are no longer supported. Eaton's replacement units offer a cost-effective means to extend the life or modernize existing equipment without the need to replace the original MCC.

Partial Discharge Testing



Contents

<i>Description</i>	<i>Page</i>
Predictive Diagnostic	
Partial Discharge Testing	V3-T10-29
Medium and High Voltage Predictive Diagnostics Online Monitoring and Partial Discharge Analysis	V3-T10-32

Partial Discharge Testing

General Description

Application

Eaton’s Electrical Services & Systems has developed state-of-the-art technology to allow for the long-term predictive diagnostics of medium voltage equipment. New or existing medium voltage switchgear lineups are equipped with partial discharge (PD) sensors to measure PD within the cubicles. The sensing technology provides measurement of all discharges through noninvasive sensing of the electrical power signal. Measurements are performed online, while switchgear equipment is energized under normal operational conditions, using measurement equipment specifically designed for this purpose.

Functionality

PD sensors detect partial discharges, which are the initial indicators of corona or surface tracking. Corona and surface tracking are the primary root-causes of insulation deterioration in medium voltage electrical equipment. The sensitivity of PD sensors and measurement technology is sufficient to detect early stages of defect development by measuring PD of low levels (less than 50 pico-coulombs). PD occurring within the cubicles as well as PD emanated by external sources (cable terminations, cables, bus ducts, connected transformers, motors, etc.) within a limited distance is identified. Sensors allow for periodic partial discharge sensing from the front of each switchgear cubicle without the need to open cubicle doors, using measurement equipment specifically for this purpose.

Eaton provides a PD sensor for each cubicle within the switchgear lineup. Sensing for PD at the ends of the switchgear lineups only is not acceptable due to the signal attenuation of PD. The sensing must occur in each individual cubicle to ensure maximum sensitivity and predictive value of the measurements.

Calibration and Baseline Measurements

New switchgear can be monitored at the factory prior to shipment, and a baseline signature of PD is provided with the switchgear. Field startup service includes obtaining a post-installation signature of the PD. In-service medium voltage switchgear, which is retrofitted with PD sensors, will have an initial baseline measurement obtained, whereas our database of switchgear PD measurements does allow us to provide immediate results concerning the insulation condition.

PD Analysis Instrumentation (for use during periodic PD measurements)

Eaton measurement and analysis instrumentation is capable of periodically detecting partial discharges related to medium voltage switchgear, medium voltage motors and generators, medium voltage cables, transformers and other medium voltage electrical equipment. It completes concurrent sampling of a minimum of four channels, able to effectively suppress electrical noise, eliminate cross-coupling of measured PD signals, maintain a detection sensitivity of 50 pC or better, and disseminate the type of discharge measured. Immediate report documentation is incorporated within the instrumentation software, with analysis and recommendations included in the final report.

Transformer Predictive Diagnostics

(Bushing Power Factor, Partial Discharge and Vibro-Acoustics)

Transformers, with a primary voltage at or above 68 kV, and containing capacitive taps on the primary bushing, should be equipped with a continuous monitoring system to allow for pre- and post-shipment measurement of bushing power factor and internal PD. In addition, vibro-acoustics testing can be completed both prior to shipment and after final installation. Vibro-acoustics testing will indicate any initial internal winding or core looseness prior to shipment, and confirm that no additional internal stress has occurred during shipment and installation. This additional field-testing provides for immediate indication of any problem related to the manufacturer, transportation, installation and startup. Vibro-acoustics also provides indication of internal looseness related to over-drying out of insulation during oil processing, and can provide diagnostic information in preparation for a transformer internal inspection. In addition, these systems provide a method to complete future predictive diagnostics, online, without any equipment outage, therefore providing extended life and increased equipment uptime.

Transformer Bushing Monitoring System

Eaton's system monitors the changes in the bushing insulation, for the set of three bushings in a group, based on changes in bushing capacitance or bushing power factor.

The system detects changes of the power frequency current through the bushing insulation. If the transformer has 6 or 9 bushings (two or three windings), additional systems can be installed as required. The measured current through the bushing insulation can not be less than 2 mA. The system also provides provisions for the connection of instrumentation for periodical PD measurements using portable equipment without requiring a transformer outage, or any modifications to the sensing circuit.

Sensors

The power factor (PF) sensors are connected to the bushing capacitance taps. All sensors are designed for outdoor installation within the ambient temperature minus 50°C to plus 50°C. Insulation level (withstand 1 minute AC voltage) between primary and secondary circuits is: bushing sensor 1.5 kV plus overvoltage protection; neutral sensor 15 kV; tank, core or cable shield grounding 2.5 kV; and 5 sheath 1.5 kV. The sensor system also includes overvoltage protection to suppress all overvoltages, arising during transformer operation, below this level. Temperature sensor, if used with a digital device, is of a standard RTD type. Sensors also provide provisions for periodic PD measurements online, using separate instrumentation designed for this purpose.

Instrumentation

Eaton's predictive analysis instrumentation is capable of precise continuous measurement of the capacitive current through the bushing insulation while the transformer is energized. The minimum detectable change in current is 0.1% of the initial current. The temperature deviation of the signal is the same order. The display is available from the bushing monitoring instrumentation for one complex PF signal per bushing group, which will include the display of the current PF value. The following output signals can also be provided as required: Two alarm signals (dry contacts) for a local alarm system, and additionally 4–20 mA DC output for an analog re-transmitting or serial interface for digital re-transmitting. Instrumentation is completely isolated from high voltages and feature immunity to high voltage transients. Full field calibration procedures are supplied with the instrument's operation manual. All necessary connections for the selected options are supplied with startup and baseline calibration.

Software (Digital Option)

Eaton's monitoring software is compatible with Microsoft® Windows® 95 or high O/S based systems with the following features: display of the PF value for the group of three bushings (up to three groups), storage and trending of the PF value for all monitored groups (up to three), trending PF readings versus temperature, alarm threshold setting, alarming upon PF reaching the preset thresholds, printing and plotting of the historical data.

Calibration, Manuals and Baseline Measurements

Eaton provides full field calibration and startup. A separate independent PF test is performed of each bushing as part of the startup and calibration process. Transformer bushings are calibrated and baseline measurements obtained. Part of the field startup service includes obtaining a post-installation baseline measurements to ensure no detects have resulted during bushing installation and/or transformer transportation, installation and startup. A report with any recommendations is also provided. A complete manual is supplied for both the instrumentation and the software describing the operation of the instrumentation, calibration and troubleshooting.

Remote Monitoring

Eaton can monitor any asset using partial discharge equipment by several secure methods including cellular, Ethernet or dial-in. Eaton has a secure APN that enables the most secure connections available and can provide monthly reporting, alarms and product support.

Online Transformer Partial Discharge Monitoring

Eaton also installs PD sensors to allow for online PD measurements within a transformer. PD measurement can be periodically obtained while the transformer is online and in normal operation, using separate instrumentation designed for this purpose. The measurement system can assess the insulation condition based on PD measurement of the bushings and the transformer windings insulation. The system is also capable of detecting sparking in the core, sparking associated with connections, and sparking associated with the static electrical discharges.

Sensors and Instrumentation

Sensors are noninvasive and have no connection to the energized components. Sensors are designed for outdoor installation within the ambient installation within the ambient temperature -50°C to $+50^{\circ}\text{C}$. Sensors are connected, as required based on the field conditions, to the following locations: bushing capacitor taps, transformer neutral connection, tank grounding, core grounding, electrostatic shield grounding, surge arresters, isophase bus enclosure bonds and grounds. The sensor frequency range of operation is 500 kHz to 50 MHz. Insulation level (withstand 1 minute AC voltage) between primary and secondary circuits is: bushing sensor 1.5 kV plus overvoltage protection; neutral sensor 15 kV; tank, core or cable shield grounding 2.5 kV; and isophase sheath 1.5 kV. The sensor system also includes overvoltage protection to suppress all overvoltages, arising during transformer operation, below this level.

Part of the field startup service includes obtaining post-installation baseline measurements to ensure no defects have resulted during bushing installation and/or transformer transportation, installation and startup. A report with any recommendations is also provided.

Measurement Parameters

Eaton's instrumentation measures the following: apparent PD magnitude of each impulse, number of impulses per cycle, phase position of each discharge impulse, impulse repetition rate, impulse discharge power, and peak discharge magnitude of the impulses. The following quantities are plotted and displayed in a report format: apparent discharge magnitude of each impulse, number of impulses per cycle, phase position of each discharge impulse, impulse repletion rate, impulse discharge power, peak discharge magnitude of the impulses, impulse count and PD magnitude vs. phase position representation and impulse PD power. The above information is provided to support the findings and recommendations, which are contained in a field report.

Vibro-Acoustic Analysis of Transformers

Eaton can perform vibro-acoustics testing prior to shipment and after final installation. Vibro-acoustics testing indicates any initial internal winding or core looseness prior to shipment, and confirms that no additional internal stress has occurred during shipment and installation.

Periodic Partial Discharge Analysis Software

Eaton's expert monitoring system applies analysis software, during periodic measurements, with the following features: display of PD data, statistical processing of the PD data, data storage and editing, and instrumentation control. All data from the test is automatically saved to a hard disk in a database format. The stored data format is compatible with Microsoft Windows applications Word®, Excel®, Access® and others. All standard "Microsoft Windows" control functions such as printing, and cut and paste operations are available within the software. Upon initiation, the software performs self-diagnostic procedures to ensure all components are operating correctly.

Calibration, Manuals and Baseline Measurements

Part of the field startup service includes obtaining post-installation baseline measurements to ensure no defects have resulted during bushing installation and/or transformer transportation, installation and startup. A report with recommendations is also provided.

Measurements

Vibro-acoustics is based on collecting steady-state vibro-acoustic data from the outside of the transformer tank under two load conditions and subsequent automated analysis of the energy distribution among different frequencies in this vibration data. The first measurement at no-load will be obtained prior to shipment. A subsequent, post-installation, no-load, vibro-acoustic measurement is also completed on-site to verify no internal stresses resulted during shipment or installation.

After the unit is loaded to approximately 50%, or greater, a second set of measurements shall be obtained. Two subsequent measurements, at 6 and 12 months, following continuous online operation, are recommended. Further follow-up measurements will be on an as-determined basis. Measurements are made at 12 locations on the transformer tank, 6 on the HV side of the transformer tank and 6 on the LV side (the HV side indicates the side with HV bushings, and the LV side indicates the side with the LV bushings).

Traditional Transformer Startup and Acceptance Testing

The above transformer predictive diagnostic systems and field startup testing is completed by Eaton in addition to traditional transformer factory and field acceptance testing in accordance with ANSI, IEEE, and other applicable testing standards. For example, a separate independent power factor test is required of each bushing as part of the startup and calibration process. These additional tests provide for immediate indication of any problem related to manufacturer, transportation, installation and startup. In addition, Eaton's predictive diagnostics provides a method to complete future predictive diagnostics, online, without any equipment outage, therefore providing extended life and increased equipment uptime.

InsulGard Predictive Relay



Contents

Description

	<i>Page</i>
Partial Discharge Testing	V3-T10-29
Medium and High Voltage Predictive Diagnostics Online Monitoring and Partial Discharge Analysis Features, Benefits and Functions	V3-T10-33

Medium and High Voltage Predictive Diagnostics Online Monitoring and Partial Discharge Analysis

General Description

Eaton’s predictive diagnostics offers predictive diagnostic equipment and systems for medium and high voltage equipment. Much of Eaton’s technology is based on the measurement and analysis of partial discharges (PD). PD is a well-known and an industry-accepted indicator of insulation deterioration that leads to equipment failure.

Studies have shown that approximately 80 percent of all equipment failures occur on a random basis and are not age related. The statistic indicates that whatever we are doing today in terms of preventive maintenance is not overly effective and that there are opportunities for major improvements.

Certainly, a well-designed, time-based preventive maintenance program will have a profound positive effect on failure rates, but they are generally invasive in nature. This invasiveness has a tendency to increase failure rates due to the introduction of new defects, resulting in infant-mortality failure patterns.

With industry moving toward fewer and shorter outages, companies are looking for alternative and predictive technologies to protect their investment, lower maintenance costs and increase system reliability. Use of the technologies provided by Eaton will do just that.

Application Description

InsulGard Predictive Relay for Continuous Monitoring and Analysis of PD

Applications of the InsulGard system are available for equipment that are rated for 4000V to 38,000V and include:

- Motors/generators (RTDs are also used as sensors)
- Switchgear systems
- Bus ducts
- Power center transformers
- Gas insulated substations
- Splices and terminations of cables

Features, Benefits and Functions

InsulGard—Transformer Monitoring System

Data gathered from Doble conferences and other scientific papers indicate that bushing failures are responsible for up to 35 percent of all large power transformer failures. This data also states that 52 percent of bushing failures are violent in nature, which presents safety concerns, as well as concerns related to environmental damage.

Among Eaton's capabilities is the ability to continuously monitor the changes in the C1 capacitance, as well as any changes in the dielectric losses of the bushing (bushing power factor). It's like having a continuous online Doble test of the bushings under true electrical stress and temperature. We also have the ability to test the bushings and the power transformer windings for PD on a periodic basis, while the equipment is in operation.

Eaton's comprehensive transformer monitoring system incorporates permanent PD sensors to timely detect a wide range of electrical problems (PDs, surface tracking, arcing, sparking) in bushings, winding insulation, core, laminations, tap changer connections, ground connections, pressboard barriers, etc. Ideal system for critical transformers or to keep your troublesome unit out of trouble! Implementation of Eaton's predictive diagnostics provides an analysis of your critical equipment to reduce the risk of failure and increase uptime.

Benefits of Using the InsulGard System

- Saves money
- No labor is required to conduct test
- More efficient deployment of personnel. Labor can be reallocated to fix problems (instead of look for them) and take care of other important matters
- Tests are performed online
- No loss of asset productivity
- More accurate data as tests are conducted under actual operating conditions
- No infant-mortality patterns that are commonly introduced via invasive testing procedures
- Tests are continuous
- Finding a problem is not left to chance (like interval testing). You will know when a problem started and how rapidly it is progressing
- No surprises and no forced outages. Increased safety—you will always be aware of conditions/problems
- Allows trending of other variables that affect PD activity such as load, temperature and humidity
- Unnecessary maintenance is reduced because you are constantly testing and have more accurate data on which to base decisions
- You have achieved predictive/conditioned-based maintenance versus interval/chance maintenance
- You can prioritize which equipment receives service first—a true maintenance planning tool

Benefits of Remote Monitoring

- Relieves the burden of data analysis
- Experts are readily available
- Safe, secure and reliable data collection
- Cost-effective—eliminates cost of expert traveling to site
- Automatic, easy to understand reports

VR-Series Breakers

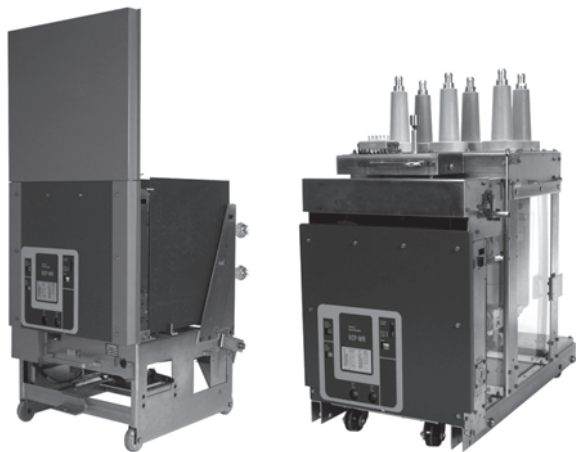

Contents

<i>Description</i>	<i>Page</i>
Retrofit Services	
Medium Voltage Vacuum Replacement Circuit Breakers	
AR Series Low Voltage Replacement Breakers . . .	V3-T10-39
Low Voltage Power Circuit Breaker Reconditioning.	V3-T10-41
Arcflash Reduction Maintenance System™ Conversions	V3-T10-45
Digitrip Microprocessor Trip Unit Retrofit Kits . . .	V3-T10-46
Low Voltage Breaker Drawout Vacuum Starter Replacement	V3-T10-50
MCC Replacement Units	V3-T10-52

Medium Voltage Vacuum Replacement Circuit Breakers

Product Description

History and Technology

Most medium voltage air magnetic power circuit breakers have been in service for 25 years and some for as long as 60 years. They were reliable and for many years maintainable. Increased short-circuit capabilities in utility and industrial power systems have created “over-duty” situations with many of these breakers. Parts availability has also increased the cost of maintaining the breakers in peak condition.

In the mid 1970s, circuit breaker manufacturers began introducing vacuum technology for medium voltage power circuit breakers. It was desirable and feasible to incorporate the advantages of vacuum technology into replacement breakers that would directly interchange with the existing medium voltage air magnetic power circuit breakers to extend the useful life of their existing switchgear. Most users wanted a replacement that was functionally interchangeable, both electrically and mechanically, with their existing medium voltage air magnetic power circuit breakers.

The market responded by offering “retrofits” that utilized the existing breaker trucks (frames) and vacuum circuit breaker modules. These alternatives provided extended life for electrical equipment, reduced maintenance, and allowed increased capabilities for many distribution systems. IEEE/ANSI established a standard for retrofits (IEEE/ANSI C37.59) in 1991 that put consistency in the retrofit process. However, retrofits were costly, caused inconvenience for users, required months to complete, and the lack of configuration control made it difficult to standardize designs.

Eaton now offers new VR circuit breakers that can be supplied in place of the old retrofit technology. Unlike retrofits, VR power circuit breakers are new from the ground up and offer improved performance, maintainability and convenience over retrofits. They can be supplied in large quantities to facilitate complete substation upgrades in a single outage. System upgrades to handle higher short-circuit levels are available.

Application Description

Eaton’s vacuum replacement (VR) circuit breakers are fully engineered and tested to provide the user with a means of modernizing electrical power distribution systems, and in most cases, extending the life of the equipment while improving performance and system reliability.

Medium voltage Type VR circuit breakers are available for 5 kV through 15 kV distribution systems.

Features, Benefits and Functions

Eaton is a world leader in circuit breaker technology. The same reliable vacuum technology is used in our VR circuit breakers. Eaton’s vacuum interrupter is used in many manufacturers’ switchgear breakers worldwide. Many of the components and sub-assemblies in Eaton medium voltage VacClad-W metal-clad switchgear are the same as those used to manufacture the VR product line. This helps reduce spare parts inventories and the amount of required maintenance training.

Eaton vacuum technology reduces maintenance since the contacts are sealed from contaminants in the environment, no adjustments or cleaning of the main contacts are required, and the main contacts require no special gauges or devices to measure wear or contact pressure. Annual lubrication and testing can be performed in a fraction of the time required for air magnetic circuit breakers.

Eaton’s non-sliding current transfer system eliminates the need to check and tighten connections between the vacuum interrupter stem and the main conductors or the circuit breaker. The connection is permanent and provides high conductivity without creating hotspots and Holm effect as found in half-clamp connections.

SURE CLOSE MOC operators are available to provide dependable MOC operation that is decoupled from the main closing function of the VR circuit breaker mechanism. This prevents the VR circuit breaker from stalling or failing to latch during the closing operation. *SURE CLOSE* mechanisms also have adjustable stop positions to control over-travel of MOC switch operators.

Service Life

Most medium voltage air magnetic circuit breakers have been in service for 25 to 60 years. As long as the bus structures, insulation systems and general mechanical condition of the switchgear cells/ structures are maintained in good condition, equipment life can easily be prolonged with the addition of VR circuit breakers.

Availability

VR breakers are available in a wide range of ratings and models to replace medium voltage, air magnetic circuit breakers originally manufactured by:

- Westinghouse
- General Electric
- Allis-Chalmers/Siemens
- Federal Pacific Electric
- ITE/ABB
- McGraw-Edison

Required Information

In order to obtain the correct VR circuit breaker, the following information should be provided to Eaton:

- Original switchgear manufacturer
- Original breaker manufacturer
- Breaker type or catalog number
- Maximum voltage rating continuous current rating and maximum short-circuit or MVA rating
- Control voltages
- List of options and/or modifications
- Copy of schematic and wiring diagram
- Year of manufacture of original breaker and switchgear
- MOC requirement

For site-specific specifications, contact your local General Field Sales Force office, or your local Engineering Services center.

Detailed Requirements

General

This section covers the design, testing and manufacturing requirements for new vacuum replacement (VR) circuit breakers for use in medium voltage metal-clad switchgear. The VR circuit breakers will be functional replacements (both mechanically and electrically) for the air magnetic circuit breakers they replace. The VR circuit breakers will be interchangeable (within the limits of the original switchgear) between different types of cells (structures) of the same voltage, MVA and ampere class without cell (structure) modifications.

Note: Retrofits, as defined by IEEE/ANSI C37.59-1996 6.1.4.2 are not covered and will not be considered as an alternative or substitute for new VR circuit breakers.

Scope of Work

Eaton’s Electrical Sector will provide all project management, factory and field engineering, short-circuit and coordination studies (if required and at an additional charge), supervision, labor, material, tools, rental, test equipment and transportation as defined for a complete VR circuit breaker replacement of the required existing medium voltage switchgear circuit breakers. The VR circuit breakers will be designed for maximum voltages of either 4.76 kV, 8.25 kV or 15 kV as required.

MVA Ratings

The available MVA rating of the VR circuit breakers are as follows:

All Eaton switchgear structures designated for VR circuit breakers with increased MVA levels will have the existing bus bracing analyzed. EESS will determine if bus bracing is capable of withstanding the maximum (peak) momentary ratings per ANSI C37.09 and ANSI C37.20.2 capabilities of the new VR circuit breakers. EESS will provide documentation to verify that the switchgear bus is sufficiently braced to handle the new ratings or supply the cost as a separate item to increase the bus bracing of all designated switchgear structures in the lineup to comply with the increased MVA ratings. Following the study and/or the bracing modifications, Eaton’s service engineer will affix a nameplate to each switchgear structure stating the new MVA rating, the manufacturer’s name and the date of verification or upgrade.

VR Ratings

Volts kV	Original MVA ^①	New MVA
4.76	100–250 ^②	250
4.77	100–250 ^②	350
8.25	150–500	500
15	150–500	500
	150–500	750
	150–500	1000
	750	1000
	150–1000	1500

Notes

- ① MVA is obsolete switchgear terminology and is used for reference only in this document.
- ② 26-inch (660.4 mm) wide cells only.

Cubicle Modifications

The VR circuit breakers are designed to be interchangeable with existing breakers of the same continuous current and MVA ratings without required modifications to the existing cubicles in most cases. Any required cell modifications are designed to be reversible. Existing cell coding systems are retained where possible.

VR circuit breakers with upgraded/increased MVA or continuous current ratings do require modifications to the cubicle coding system to prevent the insertion of breakers that do not have the same ratings as the upgraded VR circuit breakers.

Applicable Standards

All VR breakers will be designed, manufactured and tested in accordance with the applicable sections of:

- IEEE C37.59-2007 (cell interface and testing criteria)
- IEEE C37.04
- IEEE C37.06
- IEEE C37.09
- IEEE C37.20.2
- IEEE C37.100
- IEEE C37.100.1
- IEEE STD 4-1995

Materials

All materials used in the manufacturing of the new VR circuit breakers will be new and unused. No parts or materials from the original air-magnetic circuit breakers will be reconditioned and reused in the manufacture of the new VR circuit breakers. All components used in the manufacturing of the new VR circuit breakers including, mechanism, vacuum interrupters and frame components will all be manufactured by Eaton to ensure single-source reliability and responsibility.

Manufacturer's Qualifications

Eaton is currently engaged in the design and manufacturing of medium voltage vacuum circuit breakers and switchgear structures. Eaton has a minimum of 50 years experience in switchgear manufacturing, is a member of the National Electrical Manufacturers Association (NEMA), and has representation on IEEE C37 Switchgear Working and Balloting Groups, and owns and operates an engineering services organization.

Eaton's Electrical Services & Systems (EESS)

- Experienced, factory-trained field engineers and technicians familiar with the installation and startup of medium voltage VR circuit breakers
- A minimum of 30 field service locations staffed with engineers that are available on a 24-hour basis for emergency service
- Capabilities of on-site cell alignment, breaker levering system repairs and control system modifications
- Capabilities to perform computer-generated short-circuit, coordination and load flow studies for final breaker trip settings. All studies will be conducted under the supervision and approval of a registered professional electrical engineer skilled in interpreting studies and test results regarding medium voltage VR circuit breakers. The Registered Professional Electrical Engineer is a full-time employee of EESS

Vacuum Circuit Breaker Module Features

The VR circuit breakers will utilize vacuum circuit breaker modules manufactured by Eaton. Acceptable conversion modules are the VCP-18WR, VCP-20WR, VCP-29WR and the VCP-29WRSE.

Common Pole Shaft

The circuit breaker mechanism will open and close all three phases and any auxiliary devices via a common operating shaft to ensure consistent and simultaneous operation of the main contacts. The shaft will be supported at the ends and along its length with bearings. The main drive shaft will be connected to the individual vacuum interrupters via insulated drive links.

Insulated Drive Links

The mechanism drive shaft will be connected to each moving contact via an insulated drive link made of glass-reinforced polyester for element types VCP-18WR, VCP-20WR and VCP-29WR and cycloaliphatic epoxy for the VCP-29WRSE. The insulated link material is non-hydroscopic and meets the flame-retardant requirements as set forth in IEEE C37.20.2. The drive links are easily removable with single clevis pins at each end and spring retaining clips.

Shock Absorber System

The mechanism will contain a shock absorber system to dampen the opening force of the circuit breaker. The shock absorber has sufficient resilience to prevent contact bounce that could cause a restrike of the main contacts during the opening of the circuit breaker or during a spring discharge. The VCP-20WR, VCP-29WR and VCP-29WRSE vacuum conversion element's mechanism consists of a series of parallel steel plates with spring separators that spread the plates during breaker opening. The shock absorber has a design life of 10,000 breaker opening and closing cycles without the need for repair, replacement or adjustment. The VCP-18WR has a sealed replaceable shock absorber and is capable of being adjusted if replaced or during initial mechanism assembly.

Manual Trip and Close

The mechanism has front accessible manual close and trip operators that are directly connected to the breaker operating mechanism and are an integral part of the electrical close and trip coils.

Operations Counter

Each VR circuit breaker mechanism has a five digit non-resetting mechanical operations counter connected to the operating shaft.

Spring Charged Indicator

Each operating mechanism will be equipped with a visible indicator to show the state of the stored energy mechanism. The indicator will show when the spring is fully charged or discharged.

Auxiliary Contacts

The breaker will have a low inertia, rotary operated auxiliary switch connected to the main pole shaft assembly. Connections will be made via insulated ring-tongue terminals.

Vacuum Bottle Assembly

The vacuum bottle assembly will be constructed from virgin materials and manufactured by Eaton. The contacts will be principally composed of powdered metal, chromium-copper contact material. The powdered metal is fused under high pressure to form a consistent contact material. The contacts are machined to form spiral petal contacts to assist in the swirling of the arc during interruption.

The edges of the ceramic components will be "metallized" and fired prior to assembly. The components are inspected and assembled in a Class 1000 clean room prior to sealing the components. The components are inserted into a vacuum heat chamber and sealed under vacuum. No "pinch tubes" are used.

A stainless steel corrugated bellow achieves isolation of the ambient air and the vacuum. The moving contact stem of the vacuum interrupter has a machined groove to prevent rotation of the contact within the vacuum chamber.

The vacuum interrupter has a visual method of identifying contact wear without the use of gauges or other devices. In addition, a separate visual “T-cutout” is used to verify that the mechanism is applying adequate spring pressure to the contacts when the breaker is in the closed position.

The contacts are self-aligning and do not require adjustments for the life of the vacuum interrupter assembly. The contacts also have a spring system to apply proper contact pressure. The operation of the contacts cause a wiping action to clean the contact surfaces.

Insulated Pole Assemblies

Pole assemblies are insulated from ground with non-hygroscopic insulating materials manufactured from glass-reinforced polyester.

Current Transfer System

The current transfer from the conductor stem to the primary bushing assemblies is via a non-sliding current transfer system consisting of a fused stem assembly and a V-Flex™ silver-plated copper leaf conductor or folded leaf copper shunts. The stems have the adjoining conductors mechanically fused with the stem material. This junction forms a solid current transfer.

Trip-Free Operation

The new VR circuit breaker operation mechanism is a “true Trip-Free” design. When the trip function is mechanically engaged and held, and the close function is initiated either electrically or mechanically, the contacts do not close. The contacts are restricted to 10% of the total travel.

Mechanical Status Indicator

Each new VR circuit breaker has a mechanical status indicator with the word “CLOSED” on a red background when the breakers are closed and the word “OPEN” on a green background when the breakers are open.

Breaker Truck/Frame Assembly

Frame Materials and Plating

The frame is constructed from steel, utilizing a combination of bolting and welding to assemble the frames. All frames are zinc-plated with a yellow dichromate finish (commonly referred to as yellow-zinc dichromate).

Wheels and Casters for Transport

VR circuit breakers are supplied with a transport system that is a functional replacement of the transport system of the original design. The transport system conforms to the requirements of the original design.

Hardware

All hardware is a minimum grade five, zinc-plated with a yellow dichromate finish or black oxide.

Bushing and Interface Conductor Material

Primary and power frequency interface conductors are constructed of 100% IACS electrical grade conductive copper. Conductors are either silver- or tin-plated to a thickness of 0.0001–0.0002 for non-sliding surfaces and 0.001–0.002 for sliding surfaces. The power frequency conductors are sized to carry the full load ampacity of the circuit breaker without exceeding the temperature rise established in IEEE C37.09.

Insulation Systems

All bushings utilize either glass-reinforced polyester or molded cycloaliphatic epoxy insulation systems or engineer approved equal. Fluidized epoxy coatings are used to insulate interface conductors when necessary.

Phase barriers are manufactured from GPO-3 glass-reinforced polyester or equivalent and designed to isolate individual phase conductors. Openings are minimized to reduce the possibility of ionized gas propagation between phases.

Corona Shields

All 8.25 kV and 15 kV class breakers have internal corona shields when bushings are mounted on metallic back planes. The corona shields are permanently grounded. Bushings mounted on nonmetallic back planes do not have internal corona shields.

Primary Connections

Primary connections (finger clusters) are new and designed to carry the full nameplate rating of the replacement breaker without exceeding the allowable temperature rise as stated in ANSI C37.04.5.4.2-1979. In addition, the primary connections are capable of withstanding the full momentary/close and latch rating as well as the K*I current rating for two seconds without melting, arcing or pitting the contact surface.

Ground Contacts

A metal-plated, self-coupling, separable grounding contact shall be supplied.

Control Circuit Wiring

Control wiring is SIS cross-linked polyethylene, #14 AWG minimum except for short runs such as coil and motor leads. Insulated ring tongue terminals are used. Solder or “fast-on” type connections are not used. Upfront, easy access terminal blocks are provided for maintenance and troubleshooting.

Stored Energy Discharge

The replacement breaker incorporates a manual and an automatic system to completely discharge all stored energy before the circuit breaker is fully withdrawn from the switchgear housing. The system will never intentionally discharge the stored energy while in the connected position.

Passive Interlocks

The mechanism will have a passive interlock to block the insertion or removal of a closed breaker. The system also prevents the insertion of the levering tool at any time the breaker is in the closed position.

Active Interlocks

Each breaker has an active interlock system. The system is operated by the insertion or removal of the VR circuit breaker. In the event the passive interlock is defeated, active interlock system will trip and open a connected, closed breaker if an attempt is made to remove it from the connected position. The system also holds the breaker in the “trip-free” position at all times between the test and fully connected positions.

Locking Means

Locking means is provided to lock the circuit breaker while in the fully connected or disconnected positions. The lock prevents the insertion or removal of the breaker. The lock will not prevent the breaker from being operated while in the fully connected position.

Secondary Contact Block

Control wiring connections between stationary structure and the removable breaker are provided with automatic, self-coupling contacts. The secondary blocks will be mold cycloaliphatic epoxy insulation. The pins are drilled and tapped to accept standard 8-32 screws for ease of maintenance and wiring changes. The secondary contact block is made of cycloaliphatic epoxy.

MOC Operator

All breakers will be furnished with MOC operators unless specified. The MOC operator will have sufficient power to operate the largest MOC switch or combination of switches in the switchgear lineup without affecting the breaker's ability to completely close and latch. The MOC driver is completely "decoupled" from the main breaker operating shaft and shall be powered by separate operating springs. The system is *SURE CLOSE* as manufactured by Eaton's Electrical Sector.

Cell Coding System

Eaton will supply or interface with the cell coding system to prevent the accidental insertion of a breaker into a cell of a different voltage, current, interrupting capacity or physical arrangement than the type intended for the switchgear cell receiving the breaker.

Design and Certification (Type) Testing

Each new VR circuit breaker supplied will have type tests performed on its base design to certify it to IEEE/ANSI standards. All Certification (Type) shall be performed in a switchgear cell/structure when required or an equivalent structure where permitted by ANSI C37.09. Written test reports, data logs and digital reproductions of the pulse used to perform the BIL test will be on hand for review by the buyer.

BIL—60 kV for 4.76 kV applications, 95 kV for 8.25 and 15 kV applications as a minimum > crest with 1.2 μ sec x 50 μ sec x 50% wave shape per IEEE C37.09. The tests will be conducted per IEEE STD 4-1995. This test shall be performed in a breaker cell or cell equivalent with controlled humidity levels. Corrections for barometric pressure and ambient temperature will be applied to the test parameters. The breaker must pass a total of 54 shots.

Mechanical operations tests of each breaker design are performed in a switchgear cell designed to accommodate MOC switches. The maximum number of auxiliary MOC devices or their equivalent force will be applied during the test to ensure that the vacuum breaker has sufficient power to operate the auxiliary devices, successfully closes and latches during each operation, and that no fatigue or failure occurs. Consideration is given to designing a system that will not damage the MOC switch in the switchgear cell structure.

Momentary tests per IEEE C37.20.2 will be performed of the completed vacuum replacement breaker including the vacuum breaker element, bushings, primary disconnects (finger clusters), all bus in the breaker unit, and all insulators and braces per IEEE C37.09.

This test is to prove the mechanical strength and integrity of the conductor and frame assembly of the complete new vacuum replacement breaker. This test is performed in a switchgear cell designed to accommodate the circuit breaker being tested. Anti-rotation devices may be added to the cell if required to prevent rotation. If anti-rotation devices are used in the test breaker, then they will be installed in all the switchgear cells intended to accommodate the new breakers.

Short time current tests for three seconds at K^2I current will be performed to confirm the breakers I^2t capability. The test will be performed in a switchgear cell.

Continuous rated current testing per ANSI C37.04-1979 without exceeding 65°C hotspot rise with a maximum ambient not to exceed 40°C. This test is performed in a breaker cell or a cell structure of the same equivalent volume, dimensions and ventilation as the original switchgear structure.

Low Frequency Withstand—19 kV rms for 4.76 kV applications, 36 kV rms for 8.25 kV and 15 kV applications—per IEEE C37.09.

Interlock functional test per IEEE C37.20.2.

All production tests as stated in IEEE C37.09. Timing values per pole will be provided for the vacuum element in msec.

Execution

Eaton's factory trained and certified field service engineer(s) can perform the commissioning of each breaker at the customer's site. The field engineer will be familiar with the VR circuit breaker to the point that he/she can offer initial training to the owner's on-site operators and maintenance personnel while performing the commissioning.

Technical Data and Specifications**Ratings**

- Maximum voltages: 4.76 kV, 8.25 kV and 15 kV
- Interrupting ratings: 4.76 kV: 250 MVA (29 kA) 4.77 kV: 350 MVA (41 kA) 8.25 kV: 500 MVA (33 kA) 15 kV: 500 MVA (18 kA) 750 MVA (28 kA) 1000 MVA (37 kA) 1500 MVA (63 kA)
- Continuous current: 1200A, 2000A, 3000A (5–15 kV) 4000A forced cooled (5–15 kV)

AR Series Low Voltage Replacement Breakers

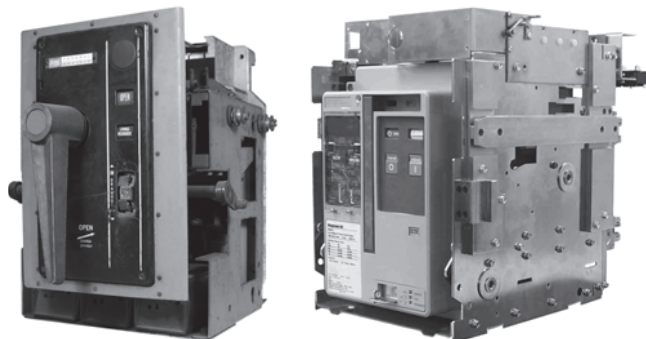

FP-25 Original Magnetic Circuit Breaker

FP25-AR Air Replacement Breaker

Contents

<i>Description</i>	<i>Page</i>
Medium Voltage Vacuum Replacement Circuit Breakers	V3-T10-34
AR Series Low Voltage Replacement Breakers	
Features	V3-T10-40
Standards and Certifications	V3-T10-40
Low Voltage Power Circuit Breaker	
Reconditioning	V3-T10-41
Arcflash Reduction Maintenance System™	
Conversions	V3-T10-45
Digitrip Microprocessor Trip Unit Retrofit Kits	V3-T10-46
Low Voltage Breaker Drawout Vacuum	
Starter Replacement	V3-T10-50
MCC Replacement Units	V3-T10-52

AR Series Low Voltage Replacement Breakers

Product Description

Application

Maximum life extension. All AR-Series breakers are brand new from the ground up. They are designed to be electrical and mechanical equivalents of the breakers they replace. Cell modifications, if required, are kept to a minimum. They are not “Retrofits” and no parts are reused from the original breakers. This reduces out-of-service time, yielding consistent product designs, while reducing initial installation costs. AR-Series breakers correctly interface with compartment cell switches, and safety interlocks are maintained or improved.

Solve Parts Availability Problems for Old Breakers

Replacement parts for old breakers are becoming harder and harder to find as technology continually advances. Parts availability issues are basically eliminated with AR-Series breakers. Mechanism parts and control components are current production items and are in stock. Additionally, AR-Series breakers use common components across the product line. This can save in future spare parts investment.

Reduce Maintenance Cost and Downtime with Reliable Magnum™ DS Breaker Technology

Maintenance procedures commonly associated with vintage air magnetic circuit breakers take 8–12 hours on average per breaker. Eaton’s Magnum DS breaker technology reduces normal maintenance to 2–6 hours per breaker. The arc chutes, contacts, mechanism and control components can be easily inspected and minor maintenance (such as lubricating the mechanism) can be easily accomplished. Arc chutes can easily be removed with two bolts and visually inspected or replaced. By removing the arc chutes, viewing the main contacts along with their contact wear indicator results in a quick and simple decision to replace if necessary. Spare parts inventory is considerably reduced because AR-Series breakers use common parts throughout the entire product line, including new Magnum DS Switchgear assemblies.

For more information on Magnum DS breaker elements, see **Volume 3, Tab 4.**

Increase Interruption Rating

Dynamic changes resulting from larger transformers, bus ties, parallel generation, and new sources of incoming power can drastically increase the level of available short-circuit current in low voltage power distribution systems. The bus system’s momentary capability can be increased and the entire switchgear structure can be re-certified to the new higher levels by Eaton’s factory qualified service engineers. Many of the AR-Series breakers are available to increase interrupting capabilities while still maintaining the original circuit breaker dimensions. This provides a savings versus the cost of replacing the switchgear. Cell-to-breaker coding systems are maintained or corrected to comply with IEEE/ANSI standards.

Increase Continuous Current Rating

Changes to industrial and commercial facilities, such as increased manufacturing operations, will typically increase the demand for electrical power within the facility. Often, an increase in electrical demand can cause the load on a circuit to exceed the circuit breaker’s continuous current rating. Eaton’s factory qualified service engineers can inspect existing low voltage metal-enclosed switchgear, including the existing breaker cubicles, line and load power stabs, load cables, and bus system to verify the application for a circuit breaker ampacity upgrade. Many of the AR-Series breakers are available with increased continuous current ratings.

Features

- AR replacement breakers are 100% rated, UL listed (check factory), and built and tested in an ISO 9001 and 14001 certified facility
- Safety: the cell door can remain closed with the breaker in connect, test or disconnect position. Simultaneously, the trip unit, open-close controls, and breaker nameplate data are all readily visible
- Designed for easy access, inspection and minimal maintenance. The stored energy mechanism, control devices, accessories and secondary contacts are easily accessible by removing the front cover. The contact wear indicator eliminates the need for elaborate testing to determine if the contact assembly needs replacing. The arc chutes can also be easily removed and inspected
- Installation savings and robust interface reduce installation and commissioning time with our unique design concept. No modifications required to the original line/load power stabs or secondary disconnect contacts. Modifications to the original cubicle are often eliminated with an easy-to-install cubicle adapter (cassette). The cassette includes new extension rails and levering-in adapters, resulting in a more robust breaker-to-cubicle interface. We also provide a new door to match the replacement breaker

Availability

Designs available for:

- Westinghouse
- General Electric
- Allis-Chalmers
- Federal Pacific
- ITE/ABB

Standards and Certifications

All AR-Series low voltage power air circuit breakers are designed and tested to meet or exceed IEEE/ANSI C37.59-2002 standards. This ensures compatibility with existing installations and IEEE/ANSI application guidelines. IEEE/ANSI certification and certified factory production test reports are available.

Low Voltage Power Circuit Breaker Reconditioning



Contents

<i>Description</i>	<i>Page</i>
Medium Voltage Vacuum Replacement Circuit Breakers	V3-T10-34
AR Series Low Voltage Replacement Breakers	V3-T10-39
Low Voltage Power Circuit Breaker Reconditioning	
Standards and Certifications	V3-T10-44
Arcflash Reduction Maintenance System™ Conversions	V3-T10-45
Digitrip Microprocessor Trip Unit Retrofit Kits	V3-T10-46
Low Voltage Breaker Drawout Vacuum Starter Replacement	V3-T10-50
MCC Replacement Units	V3-T10-52

Low Voltage Power Circuit Breaker Reconditioning

General Description

Low voltage power circuit breakers are designed to be serviceable devices over a long service life. These breakers and the associated switchgear have been available in the industry for over 50 years, and a large installed base of equipment by many manufacturers exists throughout the United States and Canada.

The low voltage switchgear is essentially static. It consists of structures, buswork, control wiring and metering components. If periodically cleaned, it will last almost indefinitely.

The low voltage power breakers are the essential elements of the switchgear. They are required to properly conduct the normal load current for the vast majority of time, and still provide the means of interrupting an overload or fault current whenever it may occur.

These breakers contain insulation systems (600 Vac normal three-phase voltage or less), conductors (from 225 to over 5000A continuous), a mechanism to open and close the breaker, a trip system to provide protection of the circuit and the circuit breaker, and an interruption system (arc chutes and contact structures) that can handle fault currents as high as 100,000A.

While some breakers are fixed mounted (bolted into the switchgear), the vast majority are drawout for ease of inspection and maintenance of the breaker, as well as to provide maximum isolation of the load. These drawout breakers include primary disconnects (for the three-phase conductors), secondary disconnects (for breaker control wiring), a levering-in mechanism (to assist in the insertion and withdrawal of the breaker) and an interlock system (to ensure that a closed breaker cannot be inserted or withdrawn from the connected position).

Additional common options to low voltage power circuit breakers include electric operation of the mechanism, shunt trip and close coils for remote operation of the breaker, undervoltage trip systems, and additional auxiliary switches for annunciation and control schemes.

Factors that affect the life of these circuit breaker subsystems include time, ambient temperature, humidity, cleanliness of the environment (contamination and corrosive elements), number of normal load operations, number of fault current interruptions, load current magnitude, and maintenance cycle.

While periodic maintenance, cleaning, lubrication and testing of the circuit breaker can and will prolong its life, at some point, the circuit breaker must either be completely reconditioned or replaced. Failure or mis-operation of any of the breaker's subsystems will render it to be ineffective for its intended purpose and dangerous for personnel or downstream equipment.

Class 1 reconditioning of the low voltage power circuit breaker is a cost-effective method to restore all of the breaker's subsystems to full functionality and prolong the life of the breaker for many additional years.

Manufacturers

Class 1 reconditioning is available for all major manufacturers' low voltage power circuit breakers that have been produced over the last 50 years. These breakers are rated at 600 Vac, 225 to 5000A continuous, 15,000 to 100,000A interrupting. The manufacturers include, but are not limited to:

- Westinghouse
- Cutler-Hammer
- General Electric
- ITE
- ABB
- Allis-Chalmers
- Siemens
- Square D
- Federal Pacific
- Federal Pioneer

Advantages

Eaton's Electrical Sector is the world leader in low voltage power circuit breaker and trip systems technology. EESS is uniquely positioned to provide Class 1 reconditioning of low voltage power circuit breakers.

All Class 1 reconditioning is done at facilities dedicated to the purpose. These are known as Aftermarket Centers of Excellence (ACEs). These facilities utilize state-of-the-art equipment in cleaning, plating, assembly and testing of the breakers. Each facility utilizes identical standards and procedures in the reconditioning process. The reconditioned breakers are tested to the same standards as new production breakers. The breaker test results are stored in a North American database (Pow-R Test), facilitating predictive maintenance and trending. All manufacturers' breaker information is stored in our Pow-R Master Database and available to every ACE performing the work. Breaker trip systems are upgraded to the latest Digitrip technology, the same trip system used in new production DS and SPB breakers. Original OEM replacement parts are exclusively used to replace broken, out of specification or missing components.

Quality Control and National Standards

All reconditioning will be conducted under the direction of a quality control and reconditioning standard, pursuant to ISO® 9001 certification. A quality certificate will document the progress of each breaker through the reconditioning process. Eaton has multiple locations (minimum of five) strategically located throughout North America that share best practices of reconditioning and work to a consistent national standard. They utilize the same task-specific equipment for cleaning and testing at all locations to ensure the quality of the product.

Receiving and Data Collection

Upon receipt at the reconditioning center, the following process will be performed on each breaker.

- Assign a unique job and breaker identification number
- Record all nameplate data, customer identification, existing trip settings, and all numbers unique to each breaker by direct entry into a national computer database archive for future use and retrieval
- If electrically operated, record all accessories included on the circuit breaker, as well as the close, trip and charge volts. The latest copy of the customer's control schematic will be obtained prior to disassembly and/or test. Eaton will have the capability of retrieving control schematics for the breakers it manufactured
- The circuit breaker will be inspected for physical damage. Parts that need to be replaced will be recorded. A quotation will be issued to the customer for replacement of the defective part(s)

Preliminary Testing and Inspection

The breaker will be manually and/or electrically operated. The following tests will be performed.

- All breakers:
 - Each primary pole insulator will be tested for dielectric integrity by applying 1000 Vdc between each conductor and ground and between line and load
 - With the breaker closed, the contact resistance using a 10 ampere conductor will be measured
 - Measure the trip bar force using a force gauge
 - Measure the trip button/ actuator device force using a force gauge
 - Verify continuity of current limiting fuses (if equipped) and measure the resistance using a 10 ampere conductor; check blown fuse indicators' integrity
 - Verify overcurrent trip device operation via primary injection (not required if a trip unit retrofit is to be installed)
- Additional tests for Electrically Operated Breakers:
 - Charge the breaker; close and trip electrically
 - Verify undervoltage, pickup and dropout (if equipped)
 - Check auxiliary switch operation and condition

Centralized Database

The results of all the above tests and measurements shall be entered into the Eaton centralized database.

Breaker Disassembly, Cleaning and Preparation

- The circuit breaker will be completely disassembled to its component parts. All parts will be inspected for wear and physical damage
- All heavily carbonized components will be cleaned and degreased in a Vaque® Wet Blast System to produce a smooth finish without degrading the component's surface
- All current carrying parts, main/arcing contacts, ground contacts and primary disconnects will be cleaned, burnished and polished in a TOREX® vibratory system loaded with a medium specifically designed to clean silver plating. Dry blasting or other abrasive cleaning systems that can remove silver plating or distort the contacts' surfaces will not be used
- All pole piece moldings and insulating components will be cleaned in a Giant™ ceramic polisher that cleans and polishes the components surface without scratching

- After cleaning, each component shall be dried to obtain 1000 megohms when megger tested at 1000 Vdc. They will be sealed with a dielectric grade sealant
 - All heavily soiled and/or greasy items including mechanisms will be initially cleaned in a non-abrasive agitator filled with a biodegradable cleaning solution capable of degreasing, de-scaling and de-burring without degrading the components surface and without the introduction or embedding of grit or other abrasive materials
 - All frames will be stripped to bare metal in preparation for plating
 - After cleaning, all ferrous metal frames, mechanism parts and linkages will be yellow zinc dichromate plated to provide superior rust resistance to exposed and hidden surfaces. Painting of covers, handles and indicators will be done
 - A detailed inspection will be performed of all mechanism components and linkages to detect stress fractures and excessive wear that can cause premature failure. Magnification will be used on small components if necessary
 - Arc chutes will be hand-wiped and cleaned with a clean dry cloth. They will be megger tested at 1000 Vdc. If the megger value is less than 1000 megohms, the arc chute assembly will be dried and retested. If the retest value is greater than 1000 megohms, then arc chute surface will be sealed with the manufacturer's recommended dielectric grade clear sealant. If the retest value is still less than 1000 megohms, then the arc chute will be replaced
 - Charging motor (if so equipped) will be removed. The drive shaft bushings will be inspected and replaced if worn. The motor will be cleaned and reconditioned. All ratchet pawls and springs will be inspected and replaced or repaired if necessary.
 - Gearbox (if equipped) will be removed, disassembled and fully inspected. Any defective or leaking components will be repaired and cleaned
- Circuit Breaker Reassembly and Adjustment will Include:**
- The circuit breaker frame will be reassembled using new yellow zinc dichromate plated hardware
 - A database of instruction books that list the original manufacturer's information on recommended lubricants. When the recommended lubricants are no longer available or have been changed, the reconditioner's new breaker design group may analyze and recommend newer, high technology lubricants as a substitute
 - The operating mechanism will be reassembled, lubricated and reinstalled on the circuit breaker frame
 - Reassemble and install the main and arcing contact components, and lubricate as recommended by the original manufacturer's information
 - Reassemble, lubricate, install and align the racking mechanism and the electrical and/or mechanical charging mechanism (if applicable)
 - Install all electrical components and secure wiring harness (if applicable)
 - Align the contacts for proper surface wipe and mating. Perform a contact wipe test. Verify that the percent contact wipe and the wipe width are per the original manufacturer's information
 - Adjust the main contacts for proper gap, pressure and contact resistance, and adjust arcing contacts for proper gap per the original manufacturer's information
 - Install new Eaton Digitrip microprocessor trip system where specified
 - When a new trip device is added to the breaker or when changes are made to the original mechanism or arc interruption system, an additional nameplate shall be installed in accordance with IEEE/ANSI C37.59-1996 Section 8.3 and shall include the unique serial/identification number

Standards and Certifications

The retrofitted breaker will be designed, manufactured, applied, installed and certification tested in accordance with the latest applicable sections of:

- IEEE/ANSI C37.13
- IEEE/ANSI C37.16
- IEEE/ANSI C37.17
- IEEE/ANSI C37.50
- IEEE/ANSI C37.59-1996
- IEEE/ANSI C37.100
- UL 1066 (For originally UL listed and labeled designs)

Test Procedures

General Production Testing

Each reconditioned low voltage power circuit breaker will be tested to the applicable sections of IEEE/ANSI C37.50 Section 6 and UL 1066 if the breaker was originally UL labeled. The testing will include, but not be limited to:

- Measuring and recording trip bar force
- Setting of the microprocessor trip
- Performing control and secondary wiring and device check tests
- Performing dielectric withstand tests
- Performing no-load operations tests
- Verifying interlock and cell interface
- Test position dielectric withstand (original UL labeled breakers only)

Trip Bar Force Measurement

Measure and record the circuit breaker's trip bar force.

Microprocessor Trip Device Setting

Direct-acting trip devices will be tested/calibrated to determine their conformance to published trip characteristic curves. Each breaker will be primary injection tested using a sinusoidal-wave-shape, single-phase 60 Hz current at a convenient voltage. The primary injection test device will be computer controlled to ensure accuracy in the applied currents. The primary injection test device will be capable of

direct output of the test results to a printer or storage device. The applicable tests will be performed.

- Long-time-delay-element pickup
- Short-time-delay-element pickup
- Instantaneous-element pickup
- Time delay of long-time-delay-element
- Time delay of short-time-delay-element
- Ground-element pickup
- Time delay of the ground element

Control, Secondary Wiring and Devices Check Test

Perform control, secondary wiring and devices checks per IEEE/ANSI C37.50.6.3 to verify that all connections are correct per the wiring diagram. Those circuits for which operation or testing is not feasible will be checked for continuity.

Dielectric Withstand Tests

Perform dielectric withstand tests per IEEE/ANSI C37.50.6.4. The applied test voltages will be essentially sinusoidal (within 20% of the rated frequency of the circuit breaker being tested) and will have a minimum crest value equal to 1.414 times the specified test voltage potentials. The potential will be increased gradually from zero so as to reach the required test value in 5 to 10 seconds, and will be held at that value for 1 minute, except for the momentary control voltages (listed in number 4 below). The following test values are applied to Class 1 reconditioned low voltage power circuit breakers.

1. 2200 Vac for the primary circuit of a completely assembled circuit breaker.
2. 1500 Vac for secondary control wiring and control devices, including current sensors and magnetic latch, except (3), (4) and (5).

3. 1000 Vac for new or reconditioned motors.
4. 500 Vac momentary for control devices and circuitry operating at 80 Vac rms (110 Vdc) or less that are not connected directly to the primary circuit or external, secondary control circuits.
5. Twice rated voltage plus 1000 Vac for undervoltage trip devices operating at a voltage above 250 Vac.

No-Load Operation Test

Perform no-load operation test per IEEE/ANSI C37.50.6.5.1 (for electrically operated breakers).

- Five closing and five opening operations at minimum control voltage
- Five closing, five opening and five trip-free operations at maximum control voltage
- Two operations to check antipumping, which will be performed in the following manner:
 - Apply uninterrupted control power to the closing circuit of the open circuit breaker as the closing signal
 - Trip the circuit breaker; the circuit to remain open until closing circuit power has been interrupted and then restored
- Check all other devices, both electrical and mechanical, for proper operation

Perform no-load operation tests per IEEE/ANSI C37.50.6.5.2 (for manually operated breakers):

- Five closing and five opening operations
- When shunt trip is used, a minimum of five openings using the shunt trip at the minimum control voltage specified for the coil
- Five trip-free operations
- Check all other devices for proper mechanical operation

Interlock and Cell Interface

Verify the functional operation of all circuit breaker interlocks and cell interfaces in a cell structure, preferably a cell in the reconditioner's facility.

Test Position Dielectric Withstand (UL Listed Breakers Only)

Original UL listed breakers will have their dielectric withstand verified by placing the breaker in the test position, closing the breaker, and applying 2200 Vac across the cell's primary conductors for 1 minute. No dielectric breakdown shall occur.

Open-Fuse Trip Device (If Included)

Test the trip device mechanically or by application of proper voltage to the device to establish positive tripping of the fused circuit breaker.

Undervoltage Test

The undervoltage device will be tested for pickup and dropout voltages.

Breaker Data History

All breaker information, unique identification number, and Eaton test results shall be recorded on the reconditioner test form and in the Eaton centralized database to track each breaker for predictive maintenance. A copy of the test form, with the test results and a quality certificate, shall be delivered with each circuit breaker.

Warranty

Each Class 1 reconditioned low voltage power circuit breaker will include Eaton's 2-year warranty.



ARMS Conversions



Contents

<i>Description</i>	<i>Page</i>
Medium Voltage Vacuum Replacement Circuit Breakers	V3-T10-34
AR Series Low Voltage Replacement Breakers . . .	V3-T10-39
Low Voltage Power Circuit Breaker Reconditioning	V3-T10-41
Arcflash Reduction Maintenance System™ Conversions	
Digitrip Microprocessor Trip Unit Retrofit Kits	V3-T10-46
Low Voltage Breaker Drawout Vacuum Starter Replacement	V3-T10-50
MCC Replacement Units	V3-T10-52

Arcflash Reduction Maintenance System™ Conversions

Product Description

A circuit breaker equipped with an Arcflash Reduction Maintenance System retrofit can improve safety by providing the worker with a simple and reliable method to reduce fault clearing time. A lockable switch that can be incorporated into a Lock Out Tag Out (LOTO) procedure controls the Arcflash Reduction Maintenance System. Workers can easily create and control fast tripping time at the work location by using this new solution. Work locations downstream of a circuit breaker with this retrofit can have a significantly lower incident energy level. The Arcflash Reduction Maintenance System can be applied to any retrofitted low voltage power breaker by modifying an existing Digitrip trip unit or retrofitting a breaker with a Digitrip retrofit kit.

Features, Benefits and Functions

- Increases worker safety by limiting exposure to arc flash energy
- Extremely easy to use
- Enabled with the circuit breaker door closed by a door-mounted lockable switch (no special PPE required)
- Used only for the time required to perform the work and is not enabled continuously
- Preserves overcurrent coordination under normal conditions
- Reduces the arc flash hazard level for the time to perform the work task
- Improves worker comfort and mobility via reduction in incident energy levels that may permit reduced levels of PPE

Retrofit Kits



Contents

<i>Description</i>	<i>Page</i>
Medium Voltage Vacuum Replacement Circuit Breakers	V3-T10-34
AR Series Low Voltage Replacement Breakers	V3-T10-39
Low Voltage Power Circuit Breaker Reconditioning	V3-T10-41
Arcflash Reduction Maintenance System™ Conversions	V3-T10-45
Digitrip Microprocessor Trip Unit Retrofit Kits	
Features	V3-T10-47
Reference Information	V3-T10-49
Product Selection	V3-T10-49
Low Voltage Breaker Drawout Vacuum Starter Replacement	V3-T10-50
MCC Replacement Units	V3-T10-52

Digitrip Microprocessor Trip Unit Retrofit Kits

Product Description

Application

Eaton's Digitrip RMS retrofit kits are fully engineered, field installable retrofit kits that enable the user to completely replace an existing tripping system. They are applicable to (600 Vac) low voltage power breakers and are designed for application on both Eaton power breakers and non-Eaton power breakers.

Digitrip RMS retrofit kits provide true rms sensing, the most accurate and current state-of-the-art technology for measuring amperage loads. True rms sensing removes the possibility of false tripping due to harmonic distortion of the power waveform and enables greater accuracy in selective coordination of the power distribution system. The microprocessor-based Digitrip trip unit also allows communications for remote monitoring to a host computer or local AEM via the PowerNet communication system.

Ratings

Digitrip RMS retrofit kits are available for a wide variety of both Eaton and non-Eaton low voltage power breaker frames. Ratings range from 100 to 4000A. Digitrip retrofit kits provide the user with adaptive flexibility due to multi-tapped current sensors and interchangeable rating plugs and programmable pickup and time delay settings.

History and Technology

In the past, there have been three types of automatic control for low voltage power breakers. Electromechanical (EM) trip units, solid-state peak sensing trip units, and state-of-the-art true rms sensing trip units.

EM trip units were initially used in the early 1950s and phased out by all manufacturers in the mid-1970s. EM trip units were composed of a solenoid, springs, a diaphragm, seals and air venting apertures. Three trip units were required per breaker. Due to age or harsh environments, these devices would fail or lose calibration. They required a great deal of preventive maintenance.

Peak sensing trip units were an improvement and provided improved reliability and accuracy. Only one trip unit was required per breaker; however, peak sensing trip units were not able to handle harmonic

conditions. They caused nuisance tripping and unnecessary downtime.

True rms trip units enable the measuring of current rather than the sensing of current. Since they are microprocessor-based digital devices, they are capable of taking discrete samples of the current waveform in each phase. By applying a mathematical algorithm, the current is accurately mapped out and measured. This method of measurement provides the ability to adapt to a changing harmonic content while providing repeatable and reliable protection.



Kit Components

Features

Digitrip retrofit kits come in several different model types. Among these types, they provide a variety of accommodating features (see Kit Type table on **Page V3-T10-48**).

True rms measurement and protection. Extremely accurate and able to accommodate harmonic content and disturbances.

Ground fault protection may be added to an existing power breaker. Ground fault protection is offered in a three-wire and a four-wire version.

Zone interlocking is available on the short time and ground fault modes of protection. This enables enhanced selectivity for high fault and ground fault coordination between the main and feeder breakers.

Local monitoring via a display. A red LED display enables the user to step through and read currents and energy readings for each phase and ground.

Communications via the PowerNet system. This allows all pertinent information, regarding static and dynamic operation of the breaker, to be remotely monitored either by a host computer or local display monitor. This facilitates energy management and power management. Remember: "If you can't measure it, you can't manage it."

Trip Functions

All Digitrip RMS retrofit kit types are available with the necessary combinations of long, short, instantaneous and ground fault (LSIG) modes of protection as depicted and deemed necessary by industry standards.

The combinations of modes of protection are:

- LI
- LS
- LSI
- LIG
- LSG
- LSIG

The Packaged Kit

Each Digitrip RMS retrofit kit includes a Digitrip trip unit, an auxiliary CT module, a Direct Trip Actuator (DTA), quantity (three or four) current sensors, a rating plug, interconnecting wiring harnesses, mounting brackets, copper connectors (when required), hardware and installation instructions. Digitrip RMS retrofit kits are complete tripping systems specifically engineered for each breaker type and frame rating. All kits are designed for field installation.

Application and Service Condition

In order to ensure that Digitrip RMS retrofit kits are successfully applied, installation must only be done by a qualified individual. Appropriate testing must be performed to qualify the retrofitted breaker prior to placing the breaker in service. Digitrip RMS retrofit kits will provide protection in accordance with their published time-current characteristic curves and in accordance with the original breaker manufacturers specifications on breakers that have been properly maintained and operate in accordance with the original manufacturer's operating instructions.

Service Life

The physical structure, the bus assemblies and control wiring of switchgear are normally in good condition. The replacement of the trip system coupled along with either refurbishment or reconditioning of the breaker will prolong the life of the switchgear and provide modern state-of-the-art protection.

Availability

Digitrip retrofit kits are currently available for select breaker frames for the following manufacturers:

- Eaton
- Westinghouse
- General Electric
- ITE
- Allis-Chalmers
- Federal Pacific
- Roller Smith
- Siemens-Allis

Additional Offerings

- Retrofit kits using OPTIM™ 750 and 1050 trip units are available for use on DS breakers

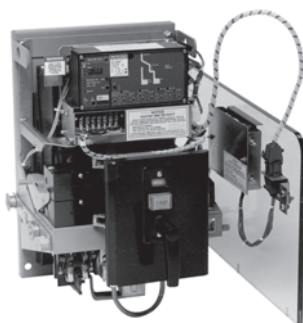

Retrofit Breaker

10.5

Power System Studies, Field Services and Conversions

Retrofit Services

Kit Type

Digitrip Kit Features	RMS 510	RMS 510 Zone	RMS 610	RMS 810	RMS 910
Cause of trip LED indicators	■	■	■	■	■
Integral self test	■	■	■	■	■
Trip reset button	■	■	■	■	■
Thermal memory hardware driven	—	—	—	—	—
Thermal memory software driven selectable (on/off)	■	■	■	■	■
Discriminator circuit on LS and LSG protection modes	—	—	—	—	—
Discriminator circuit on LS and LSG protection modes selectable (on/off)	■	■	■	■	■
Zone protective interlocking for short-time and ground fault modes of protection	—	■	■	■	■
Auxiliary contact for long time, short-circuit and ground fault functions	—	■	■	■	■
Local display of phase currents	—	—	■	■	■
Local display of ground currents	—	—	■	■	■
Local display of cause of trip	—	—	■	■	■
Local display of energy (MWh)	—	—	—	■	■
Local display of peak demand (MW)	—	—	—	■	■
Local display of present demand (MW)	—	—	—	■	■
Communication with PowerNet communicated data includes:	—	—	—	■	■
All display values					
Trip unit status					
High load alarm					
Cause of trip					
Rating plug status					
Breaker status					
Reason for breaker status					
Trip settings	—	—	—	■	■
Power factor	—	—	—	■	■
Control via the PowerNet system (open/close)	—	—	—	■	■
Voltage phase-to-phase, displayed on trip unit and communicated via PowerNet communication	—	—	—	—	■
Total current harmonic distortion (THD); phase A, B, C. Displayed on trip unit and communicated via PowerNet communication	—	—	—	—	■
Total current harmonic distortion per harmonic from the 2nd through the 27th harmonic displayed on trip unit and communicated via PowerNet communication	—	—	—	—	■
System power factor. Displayed on trip unit and communicated via PowerNet communication	—	—	—	—	■
Waveform analysis data to PowerNet computer	—	—	—	—	■

Reference Information

Sales Brochure for
Digitrip RMS Retrofit
Kits: B.22D.01.S.E

Instructions for the
Application of Digitrip RMS
Retrofit Kits on Power Circuit
Breakers: AD 33-855- 4

Digitrip RMS 510
Trip Unit: IL 29-885-B

Digitrip RMS 610
Trip Unit: IL 29-886-A

Digitrip RMS 810
Trip Unit: IL 29-888-A

Digitrip RMS 910
Trip Unit: IL 29-889-A

Time Current Curves
for DS and DSL Circuit
Breakers: AD 32-870

Retrofit Kit Product Guide
call 1-800-937-5487:
Doc. #9375487

Illustrates catalog number
system for each engineered
kit: YES Catalog Tab 17

Product Selection**Customer Required Information**

In order to obtain the proper
kit, the following information
should be provided to Eaton:

- Breaker nameplate information:
 - Manufacturer
 - Breaker type
 - Ampere frame size
 - Manually or electrically operated
- Drawout or fixed mounting
- Fused or non-fused
- Digitrip trip unit type required: 510, 610, 810, 910
- Protective functions required: LI, LSI, LS, LIG, LSG, LSIG
- Continuous current rating required (trip rating of breaker)
- Three-wire or four-wire system (determines number of sensors required)

To properly select options,
the following questions need
to be answered:

- Will customer supply 120 Vac control power or is breaker-mounted CPT needed? **Applies only to Digitrip 610, 810 and 910**
- Are zone interlocks required?
- Does the application require relay outputs from the Digitrip 610, 810 or 910 for remote indication?
- Does the breaker have an existing Amptector or Digitrip trip unit installed? If so, what is it?

DB-25 LV-VSR



Contents

<i>Description</i>	<i>Page</i>
Medium Voltage Vacuum Replacement Circuit Breakers	V3-T10-34
AR Series Low Voltage Replacement Breakers	V3-T10-39
Low Voltage Power Circuit Breaker Reconditioning	V3-T10-41
Arcflash Reduction Maintenance System™ Conversions	V3-T10-45
Digitrip Microprocessor Trip Unit Retrofit Kits	V3-T10-46
Low Voltage Breaker Drawout Vacuum Starter Replacement	
Technical Data and Specifications	V3-T10-51
MCC Replacement Units	V3-T10-52

Low Voltage Breaker Drawout Vacuum Starter Replacement

General Description

Eaton's low voltage VSR is a self-contained vacuum starter replacement for a low voltage drawout air circuit breaker used for motor starting applications.

In some cases, LV air circuit breakers are used for motor starting applications. Air circuit breakers are not designed to withstand the frequent switching service and mechanical stresses associated with repetitive motor starting duty. This is due to the breaker mechanism that must be designed to close and latch against a fault. In order to meet these requirements, the mechanism must close at high speeds with a great deal of force. Frequent closing operations stress and deteriorate the breaker mechanisms.

Eaton's LV-VSR is a self-contained replacement vacuum starter for an LV drawout air circuit breaker. The LV-VSR is interchangeable with the drawout breaker element and requires no cell modifications.

Features

Advantages

The use of an LV-VSR vacuum starter can prolong device life and significantly reduce maintenance repair and downtime.

A low voltage air circuit breaker has an effective life of 4000 operations while an LV-VSR vacuum starter has an effective life of 1,000,000 operations. For example, a motor starting application that required two starts per hour on continuous duty would require a major rebuild of the LV breaker within three months. The expected life of an LV-VSR vacuum starter would be over 50 years.

The LV-VSR vacuum starter uses state-of-the-art Eaton vacuum interrupters. The interrupters employ the latest vacuum technology with long life, resistance to environmental contaminants, and positive contact wear indicators.

The integral, solid-state, trip units used on the air circuit breakers are designed primarily for cable and transformer protection. Motors require more precisely set overcurrent devices that prevent motor damage as well as avoiding nuisance tripping. A solid-state relay, Eaton Type C440, provides overload protection and phase unbalance protection. This relay was exclusively designed for motor protection.

Motor Starter

The LV-VSR consists of an Eaton V201 vacuum contactor, Class J current limiting fuses, multi-function motor protective relay, three current transformers and an integral control power transformer.

Vacuum Contactor

Eaton's V201 vacuum contactor is designed for starting and controlling three-phase, 50/60 Hz AC motors. Current interruption is contained within the vacuum bottles and no arc byproducts are vented to the outside environment. Contact condition is given by wear indicators.

Series Current Limiting Fuses

Class J current limiting fuses provide short-circuit protection and allow a combination rating of 100 kA at 480 or 600V.

C440 Electronic Overload Relay

Eaton's C440 multi-function electronic, motor protection relay provides the following features:

- Overload protection, Class 10A, 10, 20 or 30
- Phase unbalance protection, selectable (ON/OFF)
- Ground fault selectable (ON/OFF)
- Remote reset
- Alarm relay output contact
- LED status indication
- Communication modules
 - Modbus RTU RS-485
 - DeviceNet with IO
 - PROFIBUS with IO

VSR Designs

- Westinghouse DS
- GE
- ITE
- and others

Contact EESS at 877-276-9379 for more details.

Life

Exceptional electrical and mechanical life is offered by the V201 contactor—up to 1,000,000 electrical operations and 2,500,000 mechanical operations, even under harsh conditions.

Drawout Capability

The LV-VSR is mounted on a drawout frame and maintains the safety interlocking system of the LV switchgear.

Ease of Installation

The LV-VSR may be inserted into a standard breaker compartment without modification to the compartment. The primary and secondary contact structures and drawout mechanism are identical. The LV-VSR control scheme will interface with standard switchgear wiring with no cell modifications and remote control schemes, if existing, are maintained.

Safety Features

The LV-VSR vacuum starter retains all the safety features of the LV switchgear including:

- Racking the LV-VSR vacuum starter is prevented while the contactor is in the closed position. Closing the LV-VSR vacuum starter is prevented while racking
- Breaker position indication is provided (connected, test, disconnect, remove)
- The LV-VSR vacuum starter is padlockable (optional) in either the connect, test or disconnect positions
- Positive ground connection is maintained
- Closed door tripping
- Closed-door control, if existing, can be maintained

LV-VSR Control Features

LV-VSR vacuum starter offers the following standard control features. Other devices can be supplied on request.

- Start-stop pushbuttons and run pilot light
- Eaton C440 electronic overload relay
- 2A/2B auxiliary contact
- 1A/1B trip contact (overload or short circuit)
- Provision for remote control operation
- Integral control power transformer
- Custom designed wiring schemes

Ease of Maintenance

The LV-VSR control components are front mounted for easy access.

The LV-VSR uses the same line and load finger clusters, secondary contact assemblies and drawout mechanism as the original circuit breaker. Renewal parts are readily available.

Technical Data and Specifications**Ratings**

The LV-VSR vacuum starter is rated as follows:

- Maximum continuous current—425A
- Maximum voltage rating—600V
- Short-circuit rating at 240–600V 200 kA
- Maximum motor hp at 480V 235 hp
- Maximum motor hp at 240V 117 hp
- Maximum motor hp at 600V 294 hp

ITE 5600 Series Motor Control Center Replacement Unit

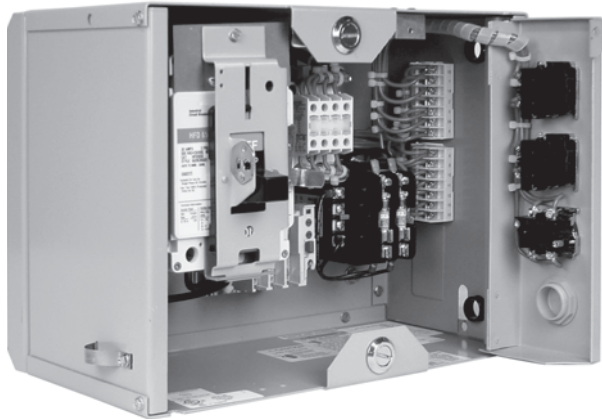

Contents

<i>Description</i>	<i>Page</i>
Medium Voltage Vacuum Replacement Circuit Breakers	V3-T10-34
AR Series Low Voltage Replacement Breakers . . .	V3-T10-39
Low Voltage Power Circuit Breaker Reconditioning	V3-T10-41
Arcflash Reduction Maintenance System™ Conversions	V3-T10-45
Digitrip Microprocessor Trip Unit Retrofit Kits	V3-T10-46
Low Voltage Breaker Drawout Vacuum Starter Replacement	V3-T10-50
MCC Replacement Units	
Standards and Certifications	V3-T10-54
Product Selection	V3-T10-54

MCC Replacement Units

General Description

Eaton's motor control center (MCC) replacement units are newly manufactured, UL labeled units designed for easy installation into existing MCCs. We manufacture units to fit into Westinghouse, Cutler-Hammer and other manufacturers such as GE, Square D and ITE.

Replacement units allow new starters and feeders to be added to existing motor control centers to replace defective units or to upgrade units.

Advantages

Motor starters are used in applications where continuous operation and frequent opening and closing are required. These conditions lead to eventual mechanical failure of contactors despite best maintenance efforts.

Replacement MCC units are the most time-efficient and cost-effective way to restore the original assembly to operational condition.

Complete replacement of the MCC involves costly demolition, removal and re-installation. Downtime is extensive. The MCC assembly often is in good condition since there is very little deterioration of the enclosure, the bus or the control wiring with normal maintenance and proper installation.

Replacement units are newly manufactured and have no used or fatigued parts. Because they can be manufactured to existing wiring diagrams, the installation time is minimal. Only the power connections and those wiring terminations external to the MCC are required to be disconnected and reconnected. The replacement unit interchanges with the existing unit without field modifications. Downtime is significantly reduced.

Features

Brand New Replacement Unit—Not a Retrofit

All motor control units, removable or fixed mounted, are assembled with Eaton components of proven safety, quality and reliability. All components are wired in accordance with NEMA and UL 845 standards.

Eaton has specifically designed bus stabs to form a standardization plug-in cell that meets the highest safety standards. These units fit into the existing space of the customer's original MCC.

Solve Parts Availability Problems for Old Unsupported Products

We can also provide additional inventory reduction for the customer by using components, such as starters, which are currently being used in other Eaton MCCs. Unit starter types include many options including: Freedom, A200 and Soft Start. Additional modifications include solid-state overloads, communication possibilities and several cover control options.

HMCP, HFD, HJD, HKD breakers and 10250T series pilot devices will provide the customer with standard features and current product to adequately maintain their MCCs for many years to come.

For additional information, contact 1-800-OLD-UNIT or your local Eaton Service Center.

New Stab Design

- Tin-plated clip surface
- Spring clip for extra pressure
- Sufficient insulating surface



Eaton Designed Stabs

Unit Features

- Holes for top and bottom incoming line
- Self-aligning stab to bus
- Door device panel
- Knockout for terminal blocks



Side Item Stab

Door Features

- Door latch—1/4 turn
- Door hinge opens farther



Door Latch Closed

Unit Features

- Easy lock-out handle mechanism
- Easy lock-in bucket tabs
- HMCP/HFD breakers 65k rated
- Additional ground clip
- 10250T series cover controls

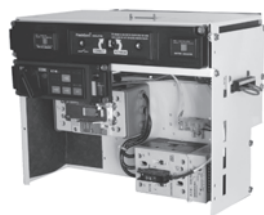

**Eaton FlashGard®
(2008 to Present)**

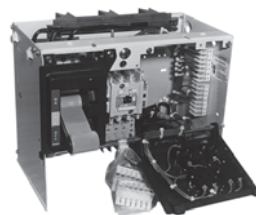

**F2100 Replacement Starter Unit
(1995 to Present)**

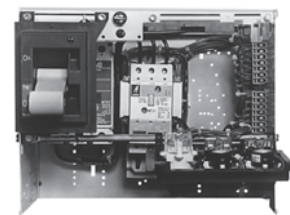

**Advantage Replacement Starter Unit
(1992 to Present)**

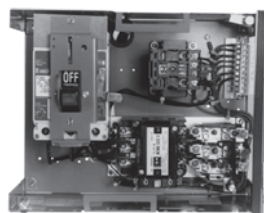

**F-10 Unitrol Replacement Starter Unit
(1972 to 1989)**

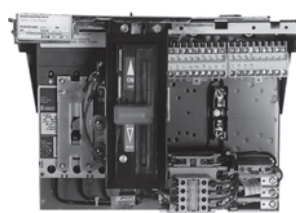

**Freedom Unitrol Replacement Starter Unit
(1988 to 1994)**

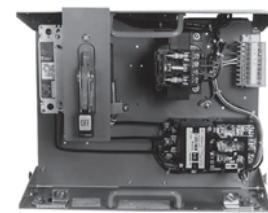

**9800 Unitrol Replacement Starter Unit
(1956 to 1974)**



**11-300 Replacement Starter Unit
(1935 to 1965)**

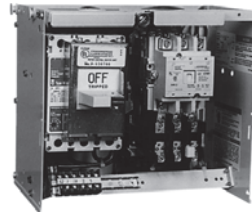

**Type W Replacement Starter Unit
(1965 to 1975)**



**5-Star/2100 Replacement Starter Unit
(1975 to 1995)**

UL 845 Eaton MCC Aftermarket Units

Name Brand	MCC	Vintage Type
Westinghouse	11-300	1935 to 1965
Cutler-Hammer	9800 Unitrol	1956 to 1974
ITE	5600 Series	1957 to 1976
Gould	5600 Series	1957 to 1976
Telemecanique	5600 Series	1957 to 1976
Westinghouse	Type W	1965 to 1975
Cutler-Hammer	F10 Unitrol	1972 to 1989
Westinghouse	5 Star	1975 to 1986
Cutler-Hammer	Freedom Unitrol	1989 to 1994
Westinghouse	2100 Series ①	1986 to 1995
Westinghouse	Advantage™ ①	1991 to present
Cutler-Hammer	Freedom 2100 ①	1995 to present
Cutler-Hammer	IT MCC	2002 to present
GE	7700/8000	1975 to present
Allen-Bradley	Centerline	1971 to present
Square D	Model 6	1992 to present
Siemens/Furnas 89	Series 89	1979 to 2001
Eaton	IT FlashGard	2006 to present
Eaton	Freedom FlashGard	2007 to present

Note

① FlashGard replacement units available.

Standards and Certifications

Designed and Tested to NEMA/UL Standards

Eaton MCC replacement units have passed all UL required short-circuit and heat tests. This high standard of testing is important to provide confidence to our customers that UL 845 units mean something for the upkeep of their equipment.



Product Selection

10

Availability

Replacement units are available for all MCCs manufactured by Eaton, Cutler-Hammer or Westinghouse. Units are available as follows:

Eaton:

- F2100: 1995 to present
- Freedom Unitro: 1988 to 1994
- F-10 Unitrol: 1972 to 1989
- 9800 Unitrol: 1956 to 1974

Westinghouse:

- Advantage: 1992 to present
- Series 2100: 1987 to 1995
- 5 Star: 1975 to 1987
- Type W: 1965 to 1975
- 11-300: 1935 to 1965

All replacement units utilize Eaton HMCP motor circuit protectors allowing the units to be UL 508 combination rated 65 kA. The units can be supplied with either Freedom, Advantage, A200 or Citation starters.

Communication Capability

Eaton's MCC communication solutions include DeviceNet, EtherNet/IP, Modbus RTU, Modbus TCP, PROFIBUS, and Web interface using Eaton's Power Xpert[®] Architecture.

Information Required

In order to obtain the proper replacement unit, the following information should be provided to Eaton:

- MCC manufacturer
- MCC type
- Required starter hp rating
- Type of starter (i.e., FVNR, FVR, 2S2W, etc.)
- Desired protective features
- Desired control devices
- Desired control scheme

Contents**Description**

Performance-Based Maintenance Services

Performance-Based Maintenance Services**General Description**

Approximately 80 percent of all equipment failures occur on a random basis and are not age-related. Certainly, a well-designed, time-based preventive maintenance program can reduce failure rates, but what about these 80 percent of equipment failures that occur on no timetable? You could increase the rate of preventive maintenance activities, but that is no panacea. These maintenance activities tend to be invasive, introducing new defects that can actually increase failure rates.

Under pressure to deliver ever higher levels of availability, facilities managers are looking for a better way. An optimal maintenance program would:

- Enable you to schedule maintenance based on actual device operation history, rather than arbitrary calendar dates
- Eliminate unnecessary maintenance work and related production outages
- Reduce spare parts requirements due to increased accuracy of equipment history
- Reduce overall maintenance costs

You can achieve these results by having Eaton apply predictive analytic technologies to the maintenance program. The result is a strategy that Eaton calls "Performance-Based Maintenance." Services are scheduled and performed based on actual device operating history, not on arbitrary calendar dates. This knowledge-based approach reduces maintenance time, cost and spare parts requirements.

Performance-Based Maintenance (PBM) Program

Eaton offers Performance-Based Maintenance (PBM) solutions that fit various project needs, for single sites or multiple sites, and a full range of equipment types. This maintenance strategy actually integrates four proven maintenance programs to deliver quantifiable results at a guaranteed price:

- **The Planned Maintenance Module** addresses operational performance, as-left conditions, environmental considerations, and testing and calibration results
- **The Predictive Diagnostic Module** focuses on visual observations, environmental and thermal conditions, and predictive indicator results
- **The Reliability-Centered Maintenance Module** concentrates on the potential for injuries, environmental hazards and product losses or process interruptions
- **The Periodic Observations Module** centers on equipment loading, and visual and environmental observations

It is easy to get started on Performance-Based Maintenance program. EESS engineers visit your facility and perform a comprehensive site audit and needs assessment. While implementing electrical system testing and maintenance, EESS engineers review both the "condition" and "criticality" of each component with plant personnel. The condition is determined via traditional preventive maintenance procedures (industry-standard, time-based) combined with predictive diagnostic technologies. The criticality rating of each component is established through application of a reliability-centered maintenance approach, taking into account its potential impact on critical processes, safety and the environment. Then, EESS engineers recommend a maintenance interval (short-, mid- or long-term) for each component, as well as work scopes and periodic observation frequency.

You save money when this analysis reveals an opportunity to lengthen maintenance interviews or reduce the scope of maintenance work performed during scheduled outages. You improve uptime and reliability when this analysis reveals components on which preventive maintenance should be performed more frequently. You can increase reliability even more by redirecting some of your cost savings into additional predictive diagnostics and equipment modernization. EESS delivers a periodic scorecard to plant personnel, summarizing the recommendations, performance and results of the program.

Elements of a Performance-Based Maintenance Program

- Site audit and maintenance needs assessment
- Condition-based maintenance
- Reliability-centered maintenance (RCM)
- Predictive diagnostics
- Efficient algorithms to integrate equipment condition results, RCM input, predictive diagnostics and periodic observations
- Recommendations for immediate action, automation, remote monitoring, life extension, spare parts or upgrading
- Periodic observations while energized and operating
- Maintenance implemented based on equipment condition and criticality
- Root-cause failure analysis
- Periodic scorecard and customized reporting of results
- Continuous improvement
- Optional ensured performance improvements and ensured savings—typically, 15 percent savings over two performance cycles

Our knowledge management practices—when applied to optimize the maintenance program—reduce the potential for outages by predicting equipment failure or system problems, decrease the duration of outages by providing 24/7 remote troubleshooting, and reduce operating and maintenance costs by basing service on real-time equipment information rather than arbitrary timelines. The bottom-line is more effective maintenance service at lower cost.

Eaton Terms & Conditions



Terms & Conditions



Contents

<i>Description</i>	<i>Page</i>
Terms and Conditions of Sale	V3-A1-1
Terms of Payment	V3-A1-2
Freight	V3-A1-3
Warranty	V3-A1-3

Selling Policy (Supersedes Selling Policy 25-000, dated February 20, 2006)

Terms and Conditions of Sale

The Terms and Conditions of Sale set forth herein, and any supplements which may be attached hereto, constitute the full and final expression of the contract for the sale of products or services (hereinafter referred to as Product(s) or Services by Eaton Corporation (hereinafter referred to as Seller) to the Buyer, and supersedes all prior quotations, purchase orders, correspondence or communications whether written or oral between the Seller and the Buyer. Notwithstanding any contrary language in the Buyer's purchase order, correspondence or other form of acknowledgment, Buyer shall be bound by these Terms and Conditions of Sale when it sends a purchase order or otherwise indicates acceptance of this contract, or when it accepts delivery from Seller of the Products or Services.

THE CONTRACT FOR SALE OF THE PRODUCTS OR SERVICES IS EXPRESSLY LIMITED TO THE TERMS AND CONDITIONS OF SALE STATED HEREIN. ANY ADDITIONAL OR DIFFERENT TERMS PROPOSED BY BUYER ARE REJECTED UNLESS EXPRESSLY AGREED TO IN WRITING BY SELLER. No contract shall exist except as herein provided.

Complete Agreement

No amendment or modification hereto nor any statement, representation or warranty not contained herein shall be binding on the Seller unless made in writing by an authorized representative of the Seller. Prior dealings, usage of the trade or a course of performance shall not be relevant to determine the meaning of this contract even though the accepting or acquiescing party had knowledge of the nature of the performance and opportunity for objection.

Quotations

Written quotations are valid for 30 days from its date unless otherwise stated in the quotation or terminated sooner by notice.

Verbal quotations, unless accepted, expire the same day they are made.

A complete signed order must be received by Seller within 20 calendar days of notification of award, otherwise the price and shipment will be subject to re-negotiation.

Termination and Cancellation

Any order may be terminated by the Buyer only by written notice and upon payment of reasonable termination charges, including all costs plus profit.

Seller shall have the right to cancel any order at any time by written notice if Buyer breaches any of the terms hereof, becomes the subject of any proceeding under state or federal law for the relief of debtors, or otherwise becomes insolvent or bankrupt, generally does not pay its debts as they become due or makes an assignment for the benefit of creditors.

Appendix 1—Eaton Terms & Conditions

Effective Date: November 1, 2008

Prices

All prices are subject to change without notice. In the event of a price change, the effective date of the change will be the date of the new price or discount sheet, letter or telegram. All quotations made or orders accepted after the effective date will be on the new basis. For existing orders, the price of the unshipped portion of an order will be the price in effect at time of shipment.

Price Policy—Products and Services

When prices are quoted as firm for quoted shipment, they are firm provided the following conditions are met:

1. The order is released with complete engineering details.
2. Shipment of Products are made, and Services purchased are provided within the quoted lead time.
3. When drawings for approval are required for any Products, the drawings applicable to those Products must be returned within 30* calendar days from the date of the original mailing of the drawings by Seller. The return drawings must be released for manufacture and shipment and must be marked "APPROVED" or "APPROVED AS NOTED." Drawing re-submittals which are required for any other reason than to correct Seller errors will not extend the 30-day period.

* 60 days for orders through contractors to allow time for their review and approval before and after transmitting them to their customers.

If the Buyer initiates or in any way causes delays in shipment, provision of Services or return of approval drawings beyond the periods stated above, the price of the Products or Services will be increased 1% per month or fraction thereof up to a maximum of 18 months from the date of the Buyer's order. For delays resulting in shipment or provision of Services beyond 18 months from the date of the Buyer's order, the price must be renegotiated.

Price Policy—BLS

Refer to Price Policy 25-050.

Minimum Billing

Orders less than \$1,000 will be assessed a shipping and handling charge of 5% of the price of the order, with a minimum charge of \$25.00 unless noted differently on Product discount sheets.

Taxes

The price does not include any taxes. Buyer shall be responsible for the payment of all taxes applicable to, or arising from the transaction, the Products, its sale, value, or use, or any Services performed in connection therewith regardless of the person or entity actually taxed.

Terms of Payment

Products

Acceptance of all orders is subject to the Buyer meeting Seller's credit requirements. Terms of payment are subject to change for failure to meet such requirements. Seller reserves the right at any time to demand full or partial payment before proceeding with a contract of sale as a result of changes in the financial condition of the Buyer. Terms of Payment are either Net 30 days from the date of invoice of each shipment or carry a cash discount based on Product type. Specific payment terms for Products are outlined in the applicable Product discount schedules.

Services

Terms of payment are net within 30 days from date of invoice for orders amounting to less than \$50,000.00.

Terms of payment for orders exceeding \$50,000.00 shall be made according to the following:

1. Twenty percent (20%) of order value with the purchase order payable 30 days from date of invoice.
2. Eighty percent (80%) of order value in equal monthly payments over the performance period payable 30 days from date of invoice.

Except for work performed (i) under a firm fixed price basis or (ii) pursuant to terms of a previously priced existing contract between Seller and Buyer, invoices for work performed by Seller shall have added and noted on each invoice a charge of 3% (over and above the price of the work) which is related to Seller compliance with present and proposed environmental, health, and safety regulations associated with prescribed requirements covering hazardous materials management and employee training, communications, personal protective equipment, documentation and record keeping associated therewith.

Adequate Assurances

If, in the judgment of Seller, the financial condition of the Buyer, at any time during the period of the contract, does not justify the terms of payment specified, Seller may require full or partial payment in advance.

Delayed Payment

If payments are not made in accordance with these terms, a service charge will, without prejudice to the right of Seller to immediate payment, be added in an amount equal to the lower of 1.5% per month or fraction thereof or the highest legal rate on the unpaid balance.

Freight

Freight policy will be listed on the Product discount sheets, or at option of Seller one of the following freight terms will be quoted.

F.O.B.—P/S—Frt./Ppd. and Invoiced

Products are sold F.O.B. point of shipment freight prepaid and invoiced to the Buyer.

F.O.B.—P/S—Frt./Ppd. and Allowed

Products sold are delivered F.O.B. point of shipment, freight prepaid and included in the price.

F.O.B. Destination—Frt./Ppd. and Allowed

At Buyer's option, Seller will deliver the Products F.O.B. destination freight prepaid and 2% will be added to the net price.

The term "freight prepaid" means that freight charges will be prepaid to the accessible common carrier delivery point nearest the destination for shipments within the United States and Puerto Rico unless noted differently on the Product discount sheets. For any other destination contact Seller's representative.

Shipment and Routing

Seller shall select the point of origin of shipment, the method of transportation, the type of carrier equipment and the routing of the shipment.

If the Buyer specifies a special method of transportation, type of carrier equipment, routing, or delivery requirement, Buyer shall pay all special freight and handling charges.

When freight is included in the price, no allowance will be made in lieu of transportation if the Buyer accepts shipment at factory, warehouse, or freight station or otherwise supplies its own transportation.

Risk of Loss

Risk of loss or damage to the Products shall pass to Buyer at the F.O.B. point.

Concealed Damage

Except in the event of F.O.B. destination shipments, Seller will not participate in any settlement of claims for concealed damage.

When shipment has been made on an F.O.B. destination basis, the Buyer must unpack immediately and, if damage is discovered must:

1. Not move the Products from the point of examination.
2. Retain shipping container and packing material.
3. Notify the carrier in writing of any apparent damage.
4. Notify Seller representative within 72 hours of delivery.
5. Send Seller a copy of the carrier's inspection report.

Witness Tests/Customer Inspection

Standard factory tests may be witnessed by the Buyer at Seller's factory for an additional charge calculated at the rate of \$2,500 per day (not to exceed eight (8) hours) per Product type. Buyer may final inspect Products at the Seller's factory for \$500 per day per Product type.

Witness tests will add one (1) week to the scheduled shipping date. Seller will notify Buyer fourteen (14) calendar days prior to scheduled witness testing or inspection. In the event Buyer is unable to attend, the Parties shall mutually agree on a rescheduled date. However, Seller reserves the right to deem the witness tests waived with the right to ship and invoice Products.

Held Orders

For any order held, delayed or rescheduled at the request of the Buyer, Seller may, at its sole option (1) require payment to be based on any reasonable basis, including but not limited to the contract price, and any additional expenses, or cost resulting from such a delay; (2) store Products at the sole cost and risk of loss of the Buyer; and/ or (3) charge to the Buyer those prices under the applicable price policy. Payment for such price, expenses and costs, in any such event, shall be due by Buyer within thirty (30) days from date of Seller's invoice. Any order so held delayed or rescheduled beyond six (6) months will be treated as a Buyer termination.

Drawing Approval

Seller will design the Products in line with, in Seller's judgment, good commercial practice. If at drawing approval Buyer makes changes outside of the design as covered in their specifications, Seller will then be paid reasonable charges and allowed a commensurate delay in shipping date based on the changes made.

Drawing Re-Submittal

When Seller agrees to do so in its quotation, Seller shall provide Buyer with the first set of factory customer approval drawing(s) at Seller's expense. The customer approval drawing(s) will be delivered at the quoted delivery date. If Buyer requests drawing changes or additions after the initial factory customer approval drawing(s) have been submitted by Seller, the Seller, at its option, may assess Buyer drawing charges. Factory customer approval drawing changes required due to misinterpretation by Seller will be at Seller's expense. Approval drawings generated by Bid Manager are excluded from this provision.

Warranty**Warranty for Products**

Seller warrants that the Products manufactured by it will conform to Seller's applicable specifications and be free from failure due to defects in workmanship and material for one (1) year from the date of installation of the Product or eighteen (18) months from the date of shipment of the Product, whichever occurs first.

In the event any Product fails to comply with the foregoing warranty Seller will, at its option, either (a) repair or replace the defective Product, or defective part or component thereof, F.O.B. Seller's facility freight prepaid, or (b) credit Buyer for the purchase price of the Product. All warranty claims shall be made in writing.

Seller requires all non-conforming Products be returned at Seller's expense for evaluation unless specifically stated otherwise in writing by Seller.

This warranty does not cover failure or damage due to storage, installation, operation or maintenance not in conformance with Seller's recommendations and industry standard practice or due to accident, misuse, abuse or negligence. This warranty does not cover reimbursement for labor, gaining access, removal, installation, temporary power or any other expenses, which may be incurred in connection with repair or replacement.

This warranty does not apply to equipment not manufactured by Seller. Seller limits itself to extending the same warranty it receives from the supplier.

Appendix 1—Eaton Terms & Conditions

Effective Date: November 1, 2008

Extended Warranty for Products

If requested by the Buyer and specifically accepted in writing by Seller, the foregoing standard warranty for Products will be extended from the date of shipment for the period and price indicated below:

- 24 months—2% of Contract Price
- 30 months—3% of Contract Price
- 36 months—4% of Contract Price

Special Warranty (In and Out) for Products

If requested by the Buyer and specifically accepted in writing by Seller, Seller will, during the warranty period for Products, at an additional cost of 2% of the contract price, be responsible for the direct cost of:

1. Removing the Product from the installed location.
2. Transportation to the repair facility and return to the site.
3. Reinstallation on site.

The total liability of Seller for this Special Warranty for Products is limited to 50% of the contract price of the particular Product being repaired and excludes expenses for removing adjacent apparatus, walls, piping, structures, temporary service, etc.

Warranty for Services

Seller warrants that the Services performed by it hereunder will be performed in accordance with generally accepted professional standards.

The Services, which do not so conform, shall be corrected by Seller upon notification in writing by the Buyer within one (1) year after completion of the Services.

Unless otherwise agreed to in writing by Seller, Seller assumes no responsibility with respect to the suitability of the Buyer's, or its customer's, equipment or with respect to any latent defects in equipment not supplied by Seller. This warranty does not cover damage to Buyer's, or its customer's, equipment, components or parts resulting in whole or in part from improper maintenance or operation or from their deteriorated condition. Buyer will, at its cost, provide Seller with unobstructed access to the defective Services, as well as adequate free working space in the immediate vicinity of the defective Services and such facilities and systems, including, without limitation, docks, cranes and utility disconnects and connects, as may be necessary in order that Seller may perform its warranty obligations. The conducting of any tests shall be mutually agreed upon and Seller shall be notified of, and may be present at, all tests that may be made.

Warranty for Power Systems Studies

Seller warrants that any power systems studies performed by it will conform to generally accepted professional standards. Any portion of the study, which does not so conform, shall be corrected by Seller upon notification in writing by the Buyer within six (6) months after completion of the study. All warranty work shall be performed in a single shift straight time basis Monday through Friday. In the event that the study requires correction of warranty items on an overtime schedule, the premium portion of such overtime shall be for the Buyer's account.

Limitation on Warranties for Products, Services and Power Systems Studies

THE FOREGOING WARRANTIES ARE EXCLUSIVE EXCEPT FOR WARRANTY OF TITLE. SELLER DISCLAIMS ALL OTHER WARRANTIES INCLUDING ANY IMPLIED WARRANTIES OF MERCHANTABILITY AND FITNESS FOR A PARTICULAR PURPOSE.

CORRECTION OF NON-CONFORMITIES IN THE MANNER AND FOR THE PERIOD OF TIME PROVIDED ABOVE SHALL CONSTITUTE SELLER'S SOLE LIABILITY AND BUYER'S EXCLUSIVE REMEDY FOR FAILURE OF SELLER TO MEET ITS WARRANTY OBLIGATIONS, WHETHER CLAIMS OF THE BUYER ARE BASED IN CONTRACT, IN TORT (INCLUDING NEGLIGENCE OR STRICT LIABILITY), OR OTHERWISE.

Asbestos

Federal Law requires that building or facility owners identify the presence, location and quantity of asbestos containing material (hereinafter "ACM") at work sites. Seller is not licensed to abate ACM. Accordingly, for any contract which includes the provision of Services, prior to (i) commencement of work at any site under a specific Purchase Order, (ii) a change in the work scope of any Purchase Order, the Buyer will certify that the work area associated with the Seller's scope of work includes the handling of Class II ACM, including but not limited to generator wedges and high temperature gaskets which include asbestos materials. The Buyer shall, at its expense, conduct abatement should the removal, handling, modification or reinstallation, or some or all of them, of said Class II ACM be likely to generate airborne asbestos fibers; and should such abatement affect the cost of or time of performance of the work then Seller shall be entitled to an equitable adjustment in the schedule, price and other pertinent affected provisions of the contract.

Compliance with Nuclear Regulation

Seller's Products are sold as commercial grade Products not intended for application in facilities or activities licensed by the United States Nuclear Regulatory Commission for atomic purposes. Further certification will be required for use of the Products in any safety-related application in any nuclear facility licensed by the U.S. Nuclear Regulatory Commission.

Returning Products

Authorization and shipping instructions for the return of any Products must be obtained from Seller before returning the Products.

When return is occasioned due to Seller error, full credit including all transportation charges will be allowed.

Product Notices

Buyer shall provide the user (including its employees) of the Products with all Seller supplied Product notices, warnings, instructions, recommendations, and similar materials.

Force Majeure

Seller shall not be liable for failure to perform or delay in performance due to fire, flood, strike or other labor difficulty, act of God, act of any governmental authority or of the Buyer, riot, embargo, fuel or energy shortage, car shortage, wrecks or delays in transportation, or due to any other cause beyond Seller's reasonable control. In the event of delay in performance due to any such cause, the date of delivery or time for completion will be extended by a period of time reasonably necessary to overcome the effect of such delay.

Liquidated Damages

Contracts which include liquidated damage clauses for failure to meet shipping or job completion promises are not acceptable or binding on Seller, unless such clauses are specifically accepted in writing by an authorized representative of the Seller at its headquarters office.

Patent Infringement

Seller will defend or, at its option, settle any suit or proceeding brought against Buyer, or Buyer's customers, to the extent it is based upon a claim that any Product or part thereof, manufactured by Seller or its subsidiaries and furnished hereunder, infringes any United States patent, other than a claim of infringement based upon use of a Product or part thereof in a process, provided Seller is notified in reasonable time and given authority, information and assistance (at Seller's expense) for the defense of same. Seller shall pay all legal and court costs and expenses and court-assessed damages awarded therein against Buyer resulting from or incident to such suit or proceeding. In addition to the foregoing, if at any time Seller determines there is a substantial question of infringement of any United States patent, and the use of such Product is or may be enjoined, Seller may, at its option and expense: either (a) procure for Buyer the right to continue using and selling the Product; (b) replace the Product with non-infringing apparatus; (c) modify the Product so it becomes non-infringing; or (d) as a last resort, remove the Product and refund the purchase price, equitably adjusted for use and obsolescence. In no case does Seller agree to pay any recovery based upon its Buyer's savings or profit through use of Seller's Products whether the use be special or ordinary. The foregoing states the entire liability of Seller for patent infringement.

The preceding paragraph does not apply to any claim of infringement based upon: (a) any modification made to a Product other than by Seller; (b) any design and/or specifications of Buyer to which a Product was manufactured; or (c) the use or combination of Product with other products where the Product does not itself infringe. As to the above-identified claim situations where the preceding paragraph does not apply, Buyer shall defend and hold Seller harmless in the same manner and to the extent as Seller's obligations described in the preceding paragraph. Buyer shall be responsible for obtaining (at Buyer's expense) all license rights required for Seller to be able to use software products in the possession of Buyer where such use is required in order to perform any Service for Buyer.

With respect to a Product or part thereof not manufactured by Seller or its subsidiaries, Seller will attempt to obtain for Buyer, from the supplier(s), the patent indemnification protection normally provided by the supplier(s) to customers.

Limitation of Liability

THE REMEDIES OF THE BUYER SET FORTH IN THIS CONTRACT ARE EXCLUSIVE AND ARE ITS SOLE REMEDIES FOR ANY FAILURE OF SELLER TO COMPLY WITH ITS OBLIGATIONS HEREUNDER.

NOTWITHSTANDING ANY PROVISION IN THIS CONTRACT TO THE CONTRARY, IN NO EVENT SHALL SELLER BE LIABLE IN CONTRACT, IN TORT (INCLUDING NEGLIGENCE OR STRICT LIABILITY) OR OTHERWISE FOR DAMAGE TO PROPERTY OR EQUIPMENT OTHER THAN PRODUCTS SOLD HEREUNDER, LOSS OF PROFITS OR REVENUE, LOSS OF USE OF PRODUCTS, COST OF

CAPITAL, CLAIMS OF CUSTOMERS OF THE BUYER OR ANY SPECIAL, INDIRECT, INCIDENTAL OR CONSEQUENTIAL DAMAGES WHATSOEVER, REGARDLESS OF WHETHER SUCH POTENTIAL DAMAGES ARE FORESEEABLE OR IF SELLER HAS BEEN ADVISED OF THE POSSIBILITY OF SUCH DAMAGES.

THE TOTAL CUMULATIVE LIABILITY OF SELLER ARISING FROM OR RELATED TO THIS CONTRACT WHETHER THE CLAIMS ARE BASED IN CONTRACT, IN TORT (INCLUDING NEGLIGENCE OR STRICT LIABILITY) OR OTHERWISE, SHALL NOT EXCEED THE PRICE OF THE PRODUCT OR SERVICES ON WHICH SUCH LIABILITY IS BASED.

A		M05	V3-T9-124
ARII	V3-T9-291	M06	V3-T9-125
		M08	V3-T9-125
B		P	
BIM	V3-T9-295	PCRMA	V3-T2-39
BLR	V3-T5-5	PCSR231	V3-T2-60
		PHRMA	V3-T2-39
D		PMURF	V3-T2-46–V3-T2-49
DIM	V3-T9-289	PX	V3-T9-19
DPONI	V3-T9-286	PXD	V3-T9-43
DP4	V3-T9-89	PXE	V3-T9-273
DT3	V3-T9-210	PXGA	V3-T9-267
		PXGX 2	V3-T9-281
E		PXGX1	V3-T9-278
ELC-P	V3-T9-267, V3-T9-273	PXG4	V3-T9-267
		PXG6	V3-T9-267
F		PXM	V3-T9-43
FP6	V3-T9-165	PXM2	V3-T9-55, V3-T9-62
FTA	V3-T2-70	PX-P	V3-T9-43
FTE	V3-T2-70	PXR	V3-T9-19
		PXS	V3-T9-19
G		Q	
GFR	V3-T9-251, V3-T9-252	Q250	V3-T9-135
		S	
H		SP1	V3-T2-22, V3-T5-5
HMURF	V3-T2-51	SP2	V3-T2-24
HURF	V3-T2-50	SRT	V3-T2-34, V3-T2-35
		S02	V3-T9-123
I		S05	V3-T9-123
IMPC	V3-T9-299	S06	V3-T9-123
IPONI	V3-T9-83, V3-T9-89, V3-T9-285	S08	V3-T9-123
IQA	V3-T9-83, V3-T9-89, V3-T9-132	S09	V3-T9-123
IQD	V3-T9-89	S21	V3-T5-5
IQDC	V3-T9-258	S61	V3-T5-5
IQES	V3-T9-116	U	
IQF	V3-T9-83, V3-T9-89, V3-T9-134	URTD	V3-T9-255
IQM	V3-T9-83, V3-T9-89	Numerics	
IQ2	V3-T9-95	100M	V3-T2-56
IQ25	V3-T9-55, V3-T9-62, V3-T9-67	100T	V3-T2-60
IQ3	V3-T9-77	1000T	V3-T2-60, V3-T2-61
		1100T	V3-T2-60, V3-T2-61
J		1200T	V3-T2-60, V3-T2-61
JMR	V3-T2-42	1234	V3-T9-252
		125M	V3-T2-56
L		125T	V3-T2-60
LDIS	V3-T9-298	1255	V3-T9-251
		1256	V3-T9-251
M		1257	V3-T9-251
MD3	V3-T9-204	1283	V3-T9-251
MINTII	V3-T9-284	150M	V3-T2-56
MP	V3-T9-83, V3-T9-89	150T	V3-T2-60, V3-T2-61
MPONI	V3-T9-83, V3-T9-89, V3-T9-287	175M	V3-T2-56
MP3	V3-T9-190	179C	V3-T9-251
MP4	V3-T9-201		
M00	V3-T9-124		
M03	V3-T9-125		
M04	V3-T9-125		

Appendix 2—Catalog Parent Number Index

200M.....	V3-T2-56	500T.....	V3-T2-60, V3-T2-61, V3-T2-65
200T.....	V3-T2-60, V3-T2-61, V3-T2-65	550T.....	V3-T2-60, V3-T2-61, V3-T2-65
225M.....	V3-T2-56	600T.....	V3-T2-60, V3-T2-61, V3-T2-65
25M.....	V3-T2-56	660T.....	V3-T2-60, V3-T2-61
250M.....	V3-T2-56	700T.....	V3-T2-60, V3-T2-61
250T.....	V3-T2-60, V3-T2-61, V3-T2-65	720T.....	V3-T2-60, V3-T2-61
300M.....	V3-T2-56	75M.....	V3-T2-56
300T.....	V3-T2-60, V3-T2-61, V3-T2-65	75T.....	V3-T2-60
350T.....	V3-T2-60, V3-T2-61, V3-T2-65	752B.....	V3-T9-252
400T.....	V3-T2-60, V3-T2-61, V3-T2-65	800T.....	V3-T2-60, V3-T2-61
450T.....	V3-T2-60, V3-T2-61, V3-T2-65	840T.....	V3-T2-60, V3-T2-61
50M.....	V3-T2-56	900T.....	V3-T2-60, V3-T2-61

A

Accessories	V3-T3-5
Automatic Insulation Tester (Motorguard)	V3-T3-5
Connectivity Options, Power Xpert Ethernet Switches	
DIN Rail Mounting Bracket	V3-T9-273
Power Supply	V3-T9-273
Rack Mount Tray, 19-inch	V3-T9-273
Control and Distribution Equipment Packaging	V3-T3-5
FlashGard Locking Accessory	V3-T3-5
FlashGard Remote Racking Accessory	V3-T3-5
Metal-Clad Vacuum Switchgear	
Ground and Test Device	V3-T7-6
Optional	V3-T7-6
Standard	V3-T7-6
Supplemental Devices	V3-T7-6
Metering Devices, IQ 130/140/150 Series	
Panel Mounting Adapter	V3-T9-67
Metering Devices, IQ 250/260 Meter	
Panel Mounting Adapter	V3-T9-62
PXM 2000 Gateway Upgrade Kit	V3-T9-62
Metering Devices, IQ Analyzer 6400/6600 Series	
IQ Auxiliary Power Supply	V3-T9-83
Metering Devices, IQ DP-4000 Series	
I/O Module	V3-T9-89
Metering Devices, Power Xpert Meter 2000 Series	
Panel Mounting Bracket	V3-T9-55
PXM 2000 Gateway Upgrade Kit	V3-T9-55
Metering Devices, Power Xpert Meter 4000/6000/8000	
Communication Expansion Card	V3-T9-43
Digital I/O Card	V3-T9-43
Graphic Display Module	V3-T9-43
Panel Mounting Bracket	V3-T9-43
Power Xpert Meter 4000 to 6000 License	
Upgrade Key	V3-T9-43
Protective Relays, Digitrip 3000	
Drawout Case	V3-T9-210
Dual-Source Power Supply	V3-T9-210
Protective Relays, Ground Fault Relay	
Ammeter Kit	V3-T9-252
Face Place	V3-T9-252
Ground Fault Warning Indicator	V3-T9-252
Shunt Trip	V3-T9-252
Test Panel (120 Vac)	V3-T9-252
Protective Relays, MP-3000 Motor Protection	V3-T9-190
Protective Relays, MP-4000 Motor Protection	V3-T9-201
Protective Relays, Universal RTD Module	V3-T9-255
Voltage Presence Indicator (VoltageVision)	V3-T3-5
Active-Harmonic Filter-Harmonic Correction Unit—	
NEMA 1 Enclosure	
Power Factor Correction Capacitors	V3-T2-71
Addressable Relay II	
Connectivity Options, Software and Connectivity	V3-T9-290
Advanced Analysis and Design Services	
Power System Studies	V3-T10-19
Advantage	
Aftermarket Products	V3-T3-3
AEGIS Powerline Filters	
Surge Protective Devices	V3-T2-25

Aftermarket Products

11-300	V3-T3-3
9800 Unitrol	V3-T3-3
Advantage	V3-T3-3
F10 Unitrol	V3-T3-3
F2100	V3-T3-3
Freedom Unitrol	V3-T3-3
IT	V3-T3-3
Series 2100/5 Star	V3-T3-3
Type W	V3-T3-3
XT and XT FlashGard	V3-T3-3

Ammeter Kit

Protective Relays, Ground Fault Relay	
Accessories	V3-T9-252

AMPGARD Motor Control

Medium Voltage Motor Control Assemblies	V3-T5-2–V3-T5-6
---	-----------------

AR Series Low Voltage Replacement Breakers

Retrofit Services	V3-T10-39
-----------------------------	-----------

Arc Flash, Short-Circuit and Coordination Studies

Power System Studies	V3-T10-12
--------------------------------	-----------

Arcflash Reduction Maintenance System Conversions

Retrofit Services	V3-T10-45
-----------------------------	-----------

Arc-Resistant AMPGARD

AMPGARD Motor Control	
Medium Voltage Motor Control Assemblies	V3-T5-3

Asset Optimization, Knowledge Management and Product Life Extension

Power System Studies, Field Services and	
Conversions	V3-T10-5

Automatic Insulation Tester (Motorguard)

.	V3-T3-5
-----------	---------

AUTOVAR 300

Power Factor Correction Capacitors	V3-T2-55
--	----------

AUTOVAR 600

Power Factor Correction Capacitors	V3-T2-58
--	----------

AUTOVAR Filter

Power Factor Correction Capacitors	V3-T2-63
--	----------

B

Bid Manager V3-T3-2

Breaker Interface Module II (BIM II)

Connectivity Options, Software and Connectivity	V3-T9-293
---	-----------

Busway Products V3-T1-1–V3-T1-7

Medium Voltage	V3-T1-2–V3-T1-7
--------------------------	-----------------

Medium Voltage Busway—Nonsegregated

Phase Bus	V3-T1-2–V3-T1-7
---------------------	-----------------

C

C-HRG Free-Standing NEMA 1 Unit

High Resistance Grounding System	V3-T7-18
--	----------

Circuit Breaker Specialized Services

Field Engineering Services	V3-T10-28
--------------------------------------	-----------

Clamp-On Current Transformers

Metering Devices	V3-T9-131
----------------------------	-----------

CM52

Network Protectors	V3-T8-2
------------------------------	---------

Appendix 3—Alphabetical Product Index

Commercial and Light Industrial Surge Protection	
PF Capacitors and Harmonic Filters	V3-T2-2
Communication Expansion Card	
Metering Devices, Power Xpert Meter 4000/6000/8000	
Accessories	V3-T9-43
Connectivity Options	V3-T9-259–V3-T9-299
Connectivity Options, Software and Connectivity	
Addressable Relay II	V3-T9-290
Breaker Interface Module II (BIM II)	V3-T9-293
DPONI	V3-T9-286
I/O Devices Digital Input Module (DIM)	V3-T9-288
IMPCABLE	V3-T9-299
IPONI	V3-T9-285
MINTII RS-232 Converter	V3-T9-284
mMINT	V3-T9-282
MPONI	V3-T9-287
Power Xpert Ethernet Switches	V3-T9-272
Power Xpert Gateway Series 1000 Card—	
Power Distribution Unit	V3-T9-276
Power Xpert Gateway Series 2000 Card—	
Uninterruptible Power Supplies	V3-T9-279
Power Xpert Gateways	V3-T9-259
Sub-Network Master Local Display (SMLD)	V3-T9-297
Consulting and Turnkey Project Management	
Field Engineering Services	V3-T10-23
Control and Distribution Equipment Packaging	V3-T3-5
Critical Load Protection	
PF Capacitors and Harmonic Filters	V3-T2-2
Current Transformers (CTs)	
Metering Devices	V3-T9-122
Customer Manufacturing and Solutions Centers	V3-T3-2
Customized High Resistance Grounding Units	
Power System Studies, Field Services and	
Conversions	V3-T10-11
CVL Surge Protective Device	
Surge Protective Devices	V3-T2-16
CVX050/100	
Surge Protective Devices	V3-T2-18
D	
Digital I/O Card	
Metering Devices, Power Xpert Meter 4000/6000/8000	
Accessories	V3-T9-43
Digitrip 3000	
Protective Relays	V3-T9-207
Digitrip Microprocessor Trip Unit Retrofit Kits	
Retrofit Services	V3-T10-46
DIN Rail Mounting Bracket	
Connectivity Options, Power Xpert Ethernet Switches	
Accessories	V3-T9-273
DP-300 Current Differential Protection Relay	
Protective Relays	V3-T9-221
DPONI	
Connectivity Options, Software and Connectivity. . .	V3-T9-286
Drawout Air Circuit Breaker Design	
Network Protectors	V3-T8-2, V3-T8-3

Drawout Case	
Protective Relays, Digitrip 3000	
Accessories	V3-T9-210
Dual-Source Power Supply	
Protective Relays, Digitrip 3000	
Accessories	V3-T9-210

E

Eaton Terms & Conditions	V3-T1-1
Freight	V3-T1-3
Limitation of Liability	V3-T1-5
Terms and Conditions of Sale	V3-T1-1
Terms of Payment	V3-T1-2
Warranty	V3-T1-3
EDR-3000 Feeder Protection	
Protective Relays	V3-T9-226
Electrical System Modernization	
Field Engineering Services	V3-T10-26
Electronic Self-Enclosed Meters	
IQ 150S/250S	V3-T9-71
Electronic Voltage Regulator	
Power Conditioning	V3-T2-36
Enclosed Meters	
Metering Devices	V3-T9-136
ETR-4000 Transformer Protection Relay	
Protective Relays	V3-T9-237

F

F10 Unitrol	
Aftermarket Products	V3-T3-3
F2100	
Aftermarket Products	V3-T3-3
Face Plate	
Protective Relays, Ground Fault Relay	
Accessories	V3-T9-252
Field Engineering Services	V3-T10-23–V3-T10-28
Circuit Breaker Specialized Services	V3-T10-28
Consulting and Turnkey Project Management	V3-T10-23
Electrical System Modernization	V3-T10-26
Predictive and Preventive Maintenance	V3-T10-25
Startup and Commissioning	V3-T10-25
System Integration	V3-T10-24
Training	V3-T10-24
FlashGuard Locking Accessory	V3-T3-5
FlashGuard Remote Racking Accessory	V3-T3-5
FP-4000 Feeder Protection	
Protective Relays	V3-T9-180
FP-5000 Feeder Protection	
Protective Relays	V3-T9-172
FP-6000 Feeder Protection	
Protective Relays	V3-T9-162
Freedom Unitrol	
Aftermarket Products	V3-T3-3

Appendix 3—Alphabetical Product Index

G

Graphic Display Module	
Metering Devices, Power Xpert Meter 4000/6000/8000	
Accessories	V3-T9-43
Ground and Test Device	
Metal-Clad Vacuum Switchgear	
Accessories	V3-T7-6
Ground Fault Relay	
Protective Relays	V3-T9-250
Ground Fault Warning Indicator	
Protective Relays, Ground Fault Relay	
Accessories	V3-T9-252

H

Harmonic Analysis Study	
Power System Studies	V3-T10-17
High Resistance Grounding System	
C-HRG Free-Standing NEMA 1 Unit	V3-T7-18
Medium Voltage Switchgear	V3-T7-18–V3-T7-26

I

I/O Devices Digital Input Module (DIM)	
Connectivity Options, Software and Connectivity. . .	V3-T9-288
I/O Module	
Metering Devices, IQ DP-4000 Series	
Accessories	V3-T9-89
IMPCABLE	
Connectivity Options, Software and Connectivity. . .	V3-T9-299
Industrial and Commercial Surge Protection	
PF Capacitors and Harmonic Filters	V3-T2-2
Instant Response Center Services	
Power System Studies, Field Services and	
Conversions	V3-T10-10
IPONI	
Connectivity Options, Software and Connectivity. . .	V3-T9-285
IQ 125 Volt DC Power Supply	
Protective Relays	V3-T9-258
IQ 130/140/150 Series Electronic Power Meters	
Metering Devices	V3-T9-66
IQ 210/220/230 Meters	
Metering Devices	V3-T9-93
IQ 250/260 Series Electronic Power Meters	
Metering Devices	V3-T9-60
IQ 35M	
Metering Devices	V3-T9-76
IQ Analyzer 6400/6600 Series	
Metering Devices	V3-T9-79
IQ Auxiliary Power Supply	
Metering Devices, IQ Analyzer	
Accessories	V3-T9-83
IQ DP-4000 Series	
Metering Devices	V3-T9-87
IQ Energy Sentinel	
Metering Devices	V3-T9-112

IQ Flange	
Metering Devices	V3-T9-134
IT.	
Aftermarket Products	V3-T3-3

L

Load Flow/Power Factor Correction Study	
Power System Studies	V3-T10-15
Low Voltage Breaker Drawout Vacuum Starter Replacement	
Retrofit Services	V3-T10-50
Low Voltage Power Circuit Breaker Reconditioning	
Retrofit Services	V3-T10-41
Low Voltage Switchgear	V3-T4-1–V3-T4-8
Magnum DS Metal-Enclosed	V3-T4-2–V3-T4-6
Primary Unit Substations	V3-T4-7, V3-T4-8
Secondary Unit Substations	V3-T4-7, V3-T4-8

M

Magnum DS Metal-Enclosed	
Low Voltage Switchgear	V3-T4-2–V3-T4-6
Main Breaker AMPGARD	
AMPGARD Motor Control	
Medium Voltage Motor Control Assemblies.	V3-T5-3
MCC Operation	V3-T3-2
MCC Replacement Units	
Retrofit Services	V3-T10-52
MD-3000 Motor/Generator Differential Relay	
Protective Relays	V3-T9-204
Medium and High Voltage Predictive Diagnostics	
Online Monitoring and Partial Discharge Analysis	
Predictive Diagnostic	V3-T10-32
Medium Voltage Busway.	V3-T1-1–V3-T1-7
Nonsegregated Phase Bus	V3-T1-2
Medium Voltage Busway—Nonsegregated Phase Bus	
Busway Products.	V3-T1-2–V3-T1-7
Medium Voltage Metal-Enclosed Switches.	V3-T6-1–V3-T6-11
Medium Voltage Switch and Breaker—MSB	V3-T6-4, V3-T6-5
Medium Voltage Switch—MVS	V3-T6-2, V3-T6-3
Metal-Enclosed Breaker—MEB	V3-T6-6, V3-T6-7
OEM Medium Voltage Switch	
Components—MVS-C.	V3-T6-10, V3-T6-11
Unitized Power Centers—UPC	V3-T6-8, V3-T6-9
Medium Voltage Motor Control Assemblies	V3-T5-1–V3-T5-6
AMPGARD Motor Control	V3-T5-2–V3-T5-6
Arc-Resistant AMPGARD	V3-T5-3
Main Breaker AMPGARD	V3-T5-3
Reduced Voltage Solid-State Starters.	V3-T5-3
SC 9000 Adjustable Frequency Drive	V3-T5-2
Medium Voltage Switch and Breaker—MSB	
Medium Voltage Metal-Enclosed Switches. . .	V3-T6-4, V3-T6-5
Medium Voltage Switchgear	V3-T7-1–V3-T7-26
High Resistance Grounding System	V3-T7-18–V3-T7-26
4200V Delta Systems	V3-T7-18
4200V Wye Systems	V3-T7-18
Metal-Clad Vacuum Switchgear	V3-T7-4–V3-T7-17
26-Inch Wide, 5 kV, 250 MVA, 1200A Switchgear . . .	V3-T7-7

Appendix 3—Alphabetical Product Index

38 kV Metal-Clad Switchgear	V3-T7-8
Accessories	V3-T7-6
Medium Voltage Switch—MVS	
Medium Voltage Metal-Enclosed Switches . . .	V3-T6-2, V3-T6-3
Medium Voltage Vacuum Replacement Circuit Breakers	
Retrofit Services	V3-T10-34
Metal-Clad Vacuum Switchgear	
Medium Voltage Switchgear	
26-Inch Wide, 5 kV, 250 MVA, 1200A Switchgear . . .	V3-T7-7
38 kV Metal-Clad Switchgear	V3-T7-8
Metal-Clad Vacuum Switchgear, VCP-W	
Accessories	
Ground and Test Device	V3-T7-6
Medium Voltage Switchgear	V3-T7-4–V3-T7-17
Metal-Enclosed Breaker—MEB	
Medium Voltage Metal-Enclosed Switches . . .	V3-T6-6, V3-T6-7
Metering Devices	V3-T9-21–V3-T9-78
Clamp-On Current Transformers	V3-T9-131
Current Transformers (CTs)	V3-T9-122
Enclosed Meters	V3-T9-136
IQ 130/140/150 Series Electronic Power Meters	V3-T9-66
IQ 150S/250S	V3-T9-71
IQ 210/220/230 Meters	V3-T9-93
IQ 250/260 Series Electronic Power Meters	V3-T9-60
IQ 35M	V3-T9-76
IQ Analyzer 6400/6600 Series	V3-T9-79
IQ DP-4000 Series	V3-T9-87
IQ Energy Sentinel	V3-T9-112
IQ Flange	V3-T9-134
Panel Mounting Adapter Kit for IQ 100/200 Series and PXM 2000 Meters	V3-T9-135
Power Xpert 4000/6000/8000 Series	V3-T9-30
Power Xpert Meter 2000 Series	V3-T9-49
Power Xpert Multi-Point Meter	V3-T9-100
Product Selection Guide	V3-T9-22
Metering Devices, Protective Relays, Software and Connectivity	V3-T9-1–V3-T9-299
Connectivity Options	V3-T9-259
Metering Devices	V3-T9-21
Monitoring Software and Reporting	V3-T9-14
Power Xpert Architecture	V3-T9-2
Protective Relays	V3-T9-158
MINTII RS-232 Converter	
Connectivity Options, Software and Connectivity . . .	V3-T9-284
mMINT	
Connectivity Options, Software and Connectivity . . .	V3-T9-282
Monitoring Software and Reporting	V3-T9-14–V3-T9-20
Power Xpert Software	V3-T9-14
Motor Control Centers	V3-T3-1–V3-T3-29
Aftermarket Products	V3-T3-3
MP-3000 Motor Protection	
Protective Relays	V3-T9-188
MP-4000 Motor Protection	
Protective Relays	V3-T9-198
MPCV	
Network Relay	V3-T8-4

MPONI	
Connectivity Options, Software and Connectivity . . .	V3-T9-287
N	
NEMA	V3-T7-18
Network Protector Aftermarket	
Rebuild and Parts Program	V3-T8-5
Network Protectors	V3-T8-1–V3-T8-5
CM52	V3-T8-2
Drawout Air Circuit Breaker Design	V3-T8-2, V3-T8-3
Network Protector Aftermarket	V3-T8-5
Network Relay	V3-T8-4
Network Relay	
MPCV	V3-T8-4
Network Protectors	V3-T8-4
Nonsegregated Phase Bus	
Medium Voltage Busway	V3-T1-2
O	
OEM Medium Voltage Switch Components—MVS-C	
Medium Voltage Metal-Enclosed Switches	V3-T6-10, V3-T6-11
P	
Panel Mounting Adapter	
Metering Devices, IQ 130/140/150 Series	
Accessories	V3-T9-67
Metering Devices, IQ 250/260 Meter	
Accessories	V3-T9-62
Panel Mounting Adapter Kit for IQ 100/200 Series and PXM 2000 Meters	
Metering Devices	V3-T9-135
Panel Mounting Bracket	
Metering Devices, Power Xpert Meter 2000 Series	
Accessories	V3-T9-55
Metering Devices, Power Xpert Meter 4000/6000/8000	
Accessories	V3-T9-43
Partial Discharge Testing	
Predictive Diagnostic	V3-T10-29
PF Capacitors and Harmonic Filters	
Commercial and Light Industrial Surge Protection	V3-T2-2
Critical Load Protection	V3-T2-2
Industrial and Commercial Surge Protection	V3-T2-2
Power Conditioning	V3-T2-3
PM3 Monitoring and Metering Module	V3-T9-121
Power Conditioning	
Electronic Voltage Regulator	V3-T2-36
PF Capacitors and Harmonic Filters	V3-T2-3
Sag Ride-Through	V3-T2-30
SPD, Power Conditioning, PF Capacitors and Harmonic Filters	V3-T2-2–V3-T2-37
Power Factor Correction Capacitors	
Active-Harmonic Filter-Harmonic Correction Unit— NEMA 1 Enclosure	V3-T2-71
AUTOVAR 300	V3-T2-55
AUTOVAR 600	V3-T2-58

Appendix 3—Alphabetical Product Index

- AUTOVAR Filter V3-T2-63
 - SPD, Power Conditioning, PF Capacitors and Harmonic Filters V3-T2-38–V3-T2-77
 - Transient-Free Static Switching Power Factor Correction Units V3-T2-67
 - UNIPAK V3-T2-44
 - UNIPUMP V3-T2-41
 - Power Supply
 - Connectivity Options, Power Xpert Ethernet Switches Accessories V3-T9-273
 - Power System Studies V3-T10-19–V3-T10-22
 - Advanced Analysis and Design Services V3-T10-19
 - Arc Flash, Short-Circuit and Coordination Studies. . . V3-T10-12
 - Harmonic Analysis Study V3-T10-17
 - Load Flow/Power Factor Correction Study V3-T10-15
 - Power System Studies, Field Services and Conversions V3-T10-1–V3-T10-54
 - Asset Optimization, Knowledge Management and Product Life Extension V3-T10-5
 - Customized High Resistance Grounding Units V3-T10-11
 - Instant Response Center Services V3-T10-10
 - Overview of Services V3-T10-10
 - Power Systems Automation Group V3-T10-8
 - Power Systems Automation Group
 - Power System Studies, Field Services and Conversions V3-T10-8
 - Power Xpert 4000/6000/8000 Series
 - Metering Devices V3-T9-30
 - Power Xpert Architecture V3-T9-2–V3-T9-13
 - Power Xpert Ethernet Switches
 - Connectivity Options, Software and Connectivity. . . V3-T9-272
 - Power Xpert Gateway Series 1000 Card—Power Distribution Unit
 - Connectivity Options, Software and Connectivity. . . V3-T9-276
 - Power Xpert Gateway Series 2000 Card—Uninterruptible Power Supplies
 - Connectivity Options, Software and Connectivity. . . V3-T9-279
 - Power Xpert Gateways
 - Connectivity Options, Software and Connectivity. . . V3-T9-259
 - Power Xpert Meter 2000 Series
 - Metering Devices V3-T9-49
 - Power Xpert Meter 4000 to 6000 License Upgrade Key
 - Metering Devices, Power Xpert Meter 4000/6000/8000 Accessories V3-T9-43
 - Power Xpert Multi-Point Meter
 - Metering Devices V3-T9-100
 - Power Xpert Software
 - Monitoring Software and Reporting V3-T9-14
 - Predictive and Preventive Maintenance
 - Field Engineering Services V3-T10-25
 - Predictive Diagnostic. V3-T10-32–V3-T10-33
 - Medium and High Voltage Predictive Diagnostics Online Monitoring and Partial Discharge Analysis . V3-T10-32
 - Partial Discharge Testing V3-T10-29
 - Primary Unit Substations
 - Low Voltage Switchgear. V3-T4-7, V3-T4-8
 - Protective Relays V3-T9-158–V3-T9-258
 - Digitrip 3000 V3-T9-207
 - DP-300 Current Differential Protection Relay V3-T9-221
 - EDR-3000 Feeder Protection. V3-T9-226
 - ETR-4000 Transformer Protection Relay V3-T9-237
 - FP-4000 Feeder Protection V3-T9-180
 - FP-5000 Feeder Protection V3-T9-172
 - FP-6000 Feeder Protection V3-T9-162
 - Ground Fault Relay V3-T9-250
 - IQ 125 Volt DC Power Supply V3-T9-258
 - MD-3000 Motor/Generator Differential Relay V3-T9-204
 - MP-3000 Motor Protection V3-T9-188
 - MP-4000 Motor Protection V3-T9-198
 - Product Selection Guide V3-T9-158
 - Universal RTD Module. V3-T9-254
 - VR-300 Multifunctional Voltage Relay V3-T9-217
 - PXM 2000 Gateway Upgrade Kit
 - Metering Devices, IQ 250/260 Meter Accessories. V3-T9-62
 - Metering Devices, Power Xpert Meter 2000 Series Accessories. V3-T9-55
- ## R
- Rack Mount Tray, 19-inch
 - Connectivity Options, Power Xpert Ethernet Switches Accessories. V3-T9-273
 - Rebuild and Parts Program
 - Network Protector Aftermarket. V3-T8-5
 - Reduced Voltage Solid-State Starters
 - AMPGARD Motor Control Medium Voltage Motor Control Assemblies. V3-T5-3
 - Renewal Parts V3-T3-3
 - Retrofit Services V3-T10-34–V3-T10-54
 - AR Series Low Voltage Replacement Breakers V3-T10-39
 - Arcflash Reduction Maintenance System Conversions V3-T10-45
 - Digitrip Microprocessor Trip Unit Retrofit Kits. V3-T10-46
 - Low Voltage Breaker Drawout Vacuum Starter Replacement. V3-T10-50
 - Low Voltage Power Circuit Breaker Reconditioning . V3-T10-41
 - MCC Replacement Units. V3-T10-52
 - Medium Voltage Vacuum Replacement Circuit Breakers. V3-T10-34
- ## S
- Sag Ride-Through
 - Power Conditioning V3-T2-30
 - SC 9000 Adjustable Frequency Drive
 - AMPGARD Motor Control Medium Voltage Motor Control Assemblies. V3-T5-2
 - Secondary Unit Substations
 - Low Voltage Switchgear V3-T4-7, V3-T4-8
 - Seismic Qualification V3-T3-2
 - Self-Enclosed Electronic Meters
 - IQ 150S/250S V3-T9-71
 - Series 2100/5 Star
 - Aftermarket Products V3-T3-3

Appendix 3—Alphabetical Product Index

Service Centers	V3-T3-3
Shunt Trip	
Protective Relays, Ground Fault Relay	
Accessories	V3-T9-252
SP1 Surge Protective Device	
Surge Protective Devices	V3-T2-21
SP2 Surge Protective Device	
Surge Protective Devices	V3-T2-23
SPD Series Integrated Units	
Surge Protective Devices	V3-T2-7
SPD Series Sidemount Units	
Surge Protective Devices	V3-T2-11
SPD, Power Conditioning, PF Capacitors and	
Harmonic Filters	V3-T2-1–V3-T2-77
Power Conditioning	V3-T2-2–V3-T2-37
Power Factor Correction Capacitors	V3-T2-38–V3-T2-77
Surge Protective Devices	V3-T2-5–V3-T2-22
Startup and Commissioning	
Field Engineering Services	V3-T10-25
Sub-Network Master Local Display (SMLD)	
Connectivity Options, Software and Connectivity. . .	V3-T9-297
Supplemental Devices	
Metal-Clad Vacuum Switchgear	
Accessories	V3-T7-6
Surge Protective Devices	
AEGIS Powerline Filters	V3-T2-25
CVL Surge Protective Device	V3-T2-16
CVX050/100	V3-T2-18
SP1 Surge Protective Device	V3-T2-21
SP2 Surge Protective Device	V3-T2-23
SPD Series Integrated Units	V3-T2-7
SPD Series Sidemount Units	V3-T2-11
SPD, Power Conditioning, PF Capacitors and	
Harmonic Filters	V3-T2-5–V3-T2-22
System Integration	
Field Engineering Services	V3-T10-24

T

Test Panel (120 Vac)	
Protective Relays, Ground Fault Relay	
Accessories	V3-T9-252
Training	
Field Engineering Services	V3-T10-24
Transient-Free Static Switching Power Factor Correction Units	
Power Factor Correction Capacitors	V3-T2-67
Type W	
Aftermarket Products	V3-T3-3

U

UNIPAK	
Power Factor Correction Capacitors	V3-T2-44–V3-T2-54
UNIPUMP	
Power Factor Correction Capacitors	V3-T2-41–V3-T2-43
Unitized Power Centers—UPC	
Medium Voltage Metal-Enclosed Switches . .	V3-T6-8, V3-T6-9

Universal RTD Module	
Protective Relays	V3-T9-254

V

VCP-W, Metal-Clad Vacuum Switchgear	
Medium Voltage Switchgear	V3-T7-4–V3-T7-17
Voltage	V3-T1-1
Voltage Presence Indicator (VoltageVision)	V3-T3-5
VR-300 Multifunctional Voltage Relay	
Protective Relays	V3-T9-217

X

XT

XT and XT FlashGard	
Aftermarket Products	V3-T3-3

Numerics

11-300	
Aftermarket Products	V3-T3-3
26-Inch Wide, 5 kV, 250 MVA, 1200A Switchgear	
Metal-Clad Vacuum Switchgear	
Medium Voltage Switchgear	V3-T7-7
38 kV Metal-Clad Switchgear	
Metal-Clad Vacuum Switchgear	
Medium Voltage Switchgear	V3-T7-8
4200V Delta Systems	
High Resistance Grounding System	
Medium Voltage Switchgear	V3-T7-18
4200V Wye Systems	
High Resistance Grounding System	
Medium Voltage Switchgear	V3-T7-18
9800 Unitrol	
Aftermarket Products	V3-T3-3