



Pre-Assembled
Sturdy Construction
Line Cords with NEMA5-15P

FEATURES

- Low-Noise versions available
- Promotes excellent air circulation
- Fully wired - ready to install

Ventilation Systems

Hubbell Premise Wiring offers a wide variety of ventilation systems for data communications applications. For full size cabinets such as HPW’s Premise Networking and Server Cabinets, roof- or rack-mounted versions can be easily installed to keep network equipment cool.

Our Premise Networking Cabinets have integral ventilation cut-outs in the doors and side covers promoting air circulation throughout. The Server Cabinet has a built-in honeycomb ventilation pattern, which covers the front and rear doors, and top. It provides a high degree of open ventilation accommodating front to rear and top to bottom cooling schemes. Both fan units occupy minimal space within the rack.

The wall mount cabinet fans for QUADCAB® and RE-BOX® enclosures increase air circulation for active equipment in confined spaces. A fan tray kit or single-units fans are available for mounting.

For All Racks/Cabinets and QUADCAB® Wall Mount Enclosures

Fan Kit

Order Information

Delivery: 1 fan tray assembly, wired, 1 kit mounting hardware.

Description Catalog No.

Fan kit, 114 CFM, 120 VAC, 60 Hz, 36 dBA **HWKF120**

Fan kit, 114 CFM, 230 VAC, 50 Hz, 36 dBA **HWKF230**

Blank plate with 4" fan/PVC conduit cut-out **H1KB**

Dimensions

HWKF120/HWK230

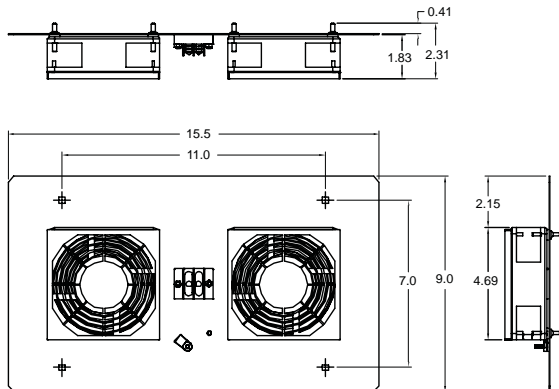

Fan Plate/Fan

Order Information

For use with Premise Networking and Server cabinets.

Delivery: 1 fan, 1 wire guard, 4 lock nuts, screws, washers, 1 cord with plug, 6’.

Description Catalog No.

Fan, 125V/7A **REKEF**

Blank plate with 4" fan/PVC conduit cut-out **H1KB**



For All Racks/Cabinets and QUADCAB® Wall Mount Enclosures

Reusable Dust Filter

Order Information

Dust filter for air intake when using fans. Recommended use with gasket kit.
 Delivery: A/R Brackets, gaskets, framed filters and 1 Kit assembly hardware.
 Catalog No. **HWKFF***
 * 2 kits are needed for 3' and 4' QUADCAB® cabinets.



For RE-BOX® Remote Equipment Cabinet

Fan Kit

Order Information

Delivery: 57-CFM fan, finger guard, disconnect power cord, 2 -prong plug, foam baffle, adhesive-backed baffle, #6-32 mounting screws, assembly bracket.
 Material: 16 ga. steel.
 Finish: black powder coat.
 NOTE: Order 1 per RE2; Order 2 per RE4, RE4X, IDF.
 Catalog No. **REKF**



Fan Filter Kit

Order Information

Cabinet dust filter for air intake when using fans (for RE4, RE4X, IDF only).
 Delivery: 1 mounting bracket, 2 foam filters, 1 assembly hardware kit.
 Catalog No. **REKFF**



Accessories for all Enclosures

Thermostat

Order Information

Delivery: 1 thermostat, 1 adhesive-backed mounting bracket, 1 wiring harness.
 Catalog No. **CTK**



Gasket Kit

Order Information

Use to enhance protection against dust and water, and performance of fan and filter.
 Delivery: 30' Padded grommet.
 Catalog No. **HWKGT**
 Delivery: One 10' adhesive-backed foam gasket.
 Catalog No. **REKG**



Hubbell Premise Wiring

HUBBELL INCORPORATED (Delaware)
 14 Lord's Hill Road • Stonington, CT 06378-0901 • (860) 535-8326 • 800-626-0005
 Fax: (860) 535-8328 • Internet site: <http://www.hubbell-premise.com>

Worldwide Locations

Hubbell Premise Wiring, Asia Pacific
 Hubbell Canada Inc.
 Hubbell Premise Wiring, Central America
 Hubbell Premise Wiring, China
 Hubbell Premise Wiring, Colombia
 Hubbell Premise Wiring, Europe
 Hubbell Int'l. Inc., Korea Branch

852-2836-7131 Fax: 852-2836-7132
 905-839-1138 Fax: 905-839-9108
 506-309-4158 Fax: 506-260-1616
 8621-6309-0119 Fax: 8621-6309-0122
 571-245-8940 Fax: 571-340-0925
 44-01283 500500 Fax: 44-01283 500400
 82-2-(0)2607-1363 Fax: 82-2-(0)2603-7386

Hubbell Premise Wiring, Latin America
 Hubbell de Mexico, S.A. de C.V.
 Hubbell Premise Wiring, Middle East
 Hubbell-Taian Co., Ltd., Taiwan
 Hubbell Premise Wiring, Turkey
 Hubbell Premise Wiring, Venezuela

305-408-4501 Fax: 305-408-8201
 (5255) 9151-9999 Fax: (5255) 9151-9989
 971-4-393-4192 Fax: 971-4-393-4194
 886-2-2522-1862 Fax: 886-2-2522-1872
 90-216-313-5016 Fax: 90-216-414-8148
 58-416-680-7453 Fax: 58-281-274-7900