

Splice Plates

Snap-In Splice Plate



Designed to lock into place for easy alignment and installation.

Packaged in pairs with zinc plated hardware.

Provided as standard with each straight and fitting.

Cat. No.	Material	Siderail Height
ABW-4-SSP	Aluminum	4
ABW-5-SSP		5
ABW-6-SSP		6
ABW-7-SSP		7

Snap-In Expansion Splice Plate

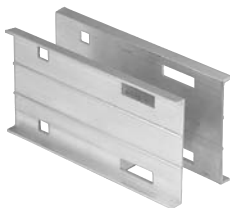

Allows for a 1 in. expansion or contraction of tray system.

Packaged in pairs with zinc plated hardware.

Cat. No.	Material	Siderail Height
ABW-4-ESP	Aluminum	4
ABW-5-ESP		5
ABW-6-ESP		6
ABW-7-ESP		7

Horizontal Adjustable Plate

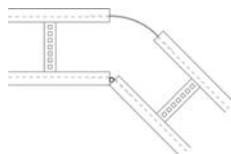
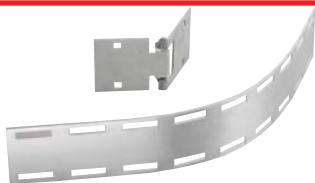

Adjustable hinge plates provide maximum horizontal installation flexibility. Furnished in pairs with hardware..

Cat. No.	Material	Siderail Height (in.)	For Tray Width
ABW(*)24HSP	Aluminum	4	6 in. to 24 in. inclusive
		5	
ABW(*)36HSP		6	30 in. to 36 in. inclusive
		7	

(*) Insert Siderail Height.

Vertical Adjustable Plate

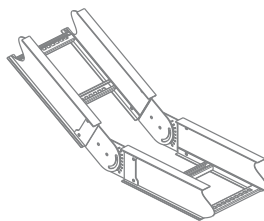
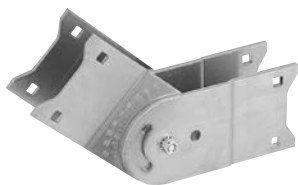

Hinged vertical plates provide maximum flexibility for changes in elevation.

Furnished in pairs with hardware.

Cat. No.	Material	Siderail Height in.
ABW-4-VSP	Aluminum	4
ABW-5-VSP		5
ABW-6-VSP		6
ABW-7-VSP		7

T&B aluminum cable tray is composed of two distinct systems H-Style and U-Style. These systems are interchangeable.

Splice Plates

Branch Pivot Connectors



Allows cables to run from one tray level to another.

Cat. No.	Material	Siderail Height (in.)
ABW-4-BPC	Aluminum	4
ABW-5-BPC		5
ABW-6-BPC		6
ABW-7-BPC		7

Box to Tray Plates



Designed to secure tray to electrical panels or boxes, walls or end supports. Furnished in pairs with hardware.

Cat. No.	Material	Siderail Height (in.)
ABW-4-BSP	Aluminum	4
ABW-5-BSP		5
ABW-6-BSP		6
ABW-7-BSP		7

Closure End Plate

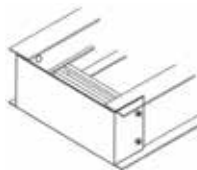

Provides closure for any tray end. Packaged with hardware.

Cat. No.	Material	Siderail Height (in.)	Widths of Tray (in.)
ABW-4-ESP	Aluminum	4	06
			09
ABW-5-ESP		5	12
			18
ABW-6-ESP	6	24	
		30	
ABW-7-ESP	7	36	

(*) Insert width of Tray.

Reducing Splice Plate

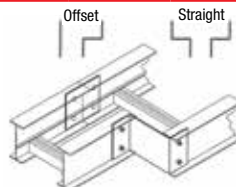
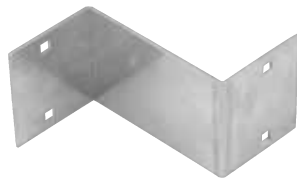

Used in pairs to provide a straight reduction or used with a standard splice plate for an offset reduction. Packaged with hardware.

Cat. No.	Material	Siderail Height (in.)
ABW-4(*)-RSP	Aluminum	4
ABW-5(*)-RSP		5
ABW-6(*)-RSP		6
ABW-7(*)-RSP		7

NOTE: (*) For offset reduction: insert width to be reduced. For straight reduction: insert 1/2 width to be reduced (2 required). Example: ABW-403-RSP = 3 in. offset reducer.

Step Down Splice Plate

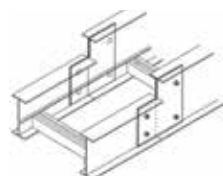
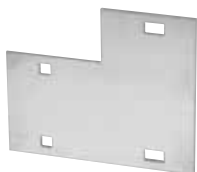

Connects siderails of different heights. Hardware included.

Cat. No.	Material	Siderail Height (in.)
ABW(*)(**)-SDS	Aluminum	4
(*) Siderail Height 1. (**) Siderail Height 2. NOTE: Siderail Height 1 is greater than Siderail Height 2.		5
		6
		7

T&B aluminum cable tray is composed of two distinct systems H-Style and U-Style. These systems are interchangeable.

Splice Plates

Mid-Span Splice Plate

Aluminum Mid-Span Splice Plate



Features

- Factory pre-drilled side rails for above series easy installation.
- Allows random connexion location.
- Tested loading 160 lb./ft., based on a 20 ft.. simple beam test with 1.5 safety factor (tested with AH66 series).
- Supplied with stainless steel type 316 hardware.
- Available on ladder, vented or solid tray style.
- Only available in the following series of aluminum tray: AH46, AH56, AH66 and AH76*.
*(20 ft.. Support Span only).

The Splice Plate

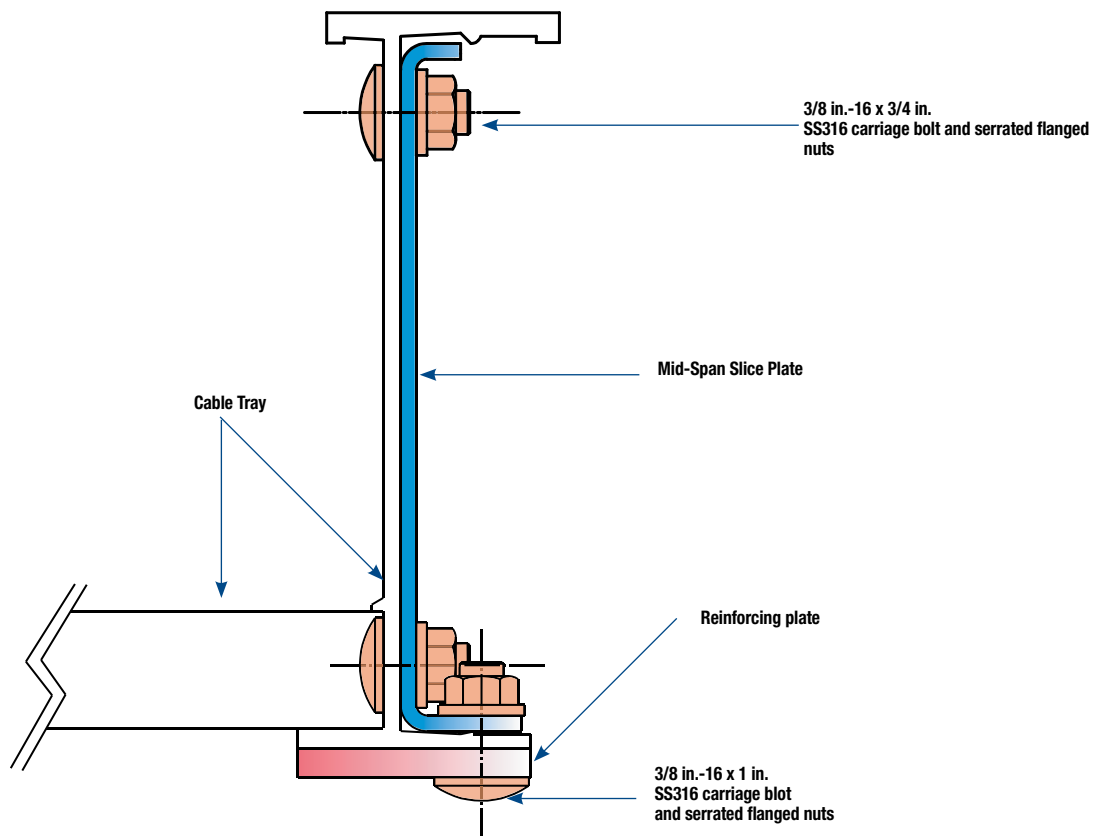

Part #: ABW6SSPMS

Splice Plates

Mid-Span Splice Plate

Typical Installation of Mid-Span Splice Plate



These heavy-duty splice plates are designed to allow random splice location, including the midspan for 20 ft.. support spans. These splices are available for all long-span, ladder, vented or solid tray style.

Straight Section Number Selection

(AMS4-6)-24-L09-6

Material	Series	Siderail Depth	Width	Bottom Type	Length
AMS • Mid-Span Splice	4 • Series 4 5 • Series 5 6 • Series 6 7 • Series 7	6 • (6 in.)	06 • (6 in.) 09 • (9 in.) 12 • (12 in.) 18 • (18 in.) 24 • (24 in.) 30 • (30 in.) 36 • (36 in.)	L06 • 6 in. rung spacing L09 • 9 in. rung spacing L12 • 12 in. rung spacing V • Ventilated S • Solid Trough	6 • (6 meters) 288 • (24 ft.)
Prefix					

To order straight sections with Mid-Span Splice Plate, replace "AH" in the standard part number with "AMS".

Example: **AH**6624L12-6
AMS6624L12-6

Splice Plates

Over Support Splice Adaptor

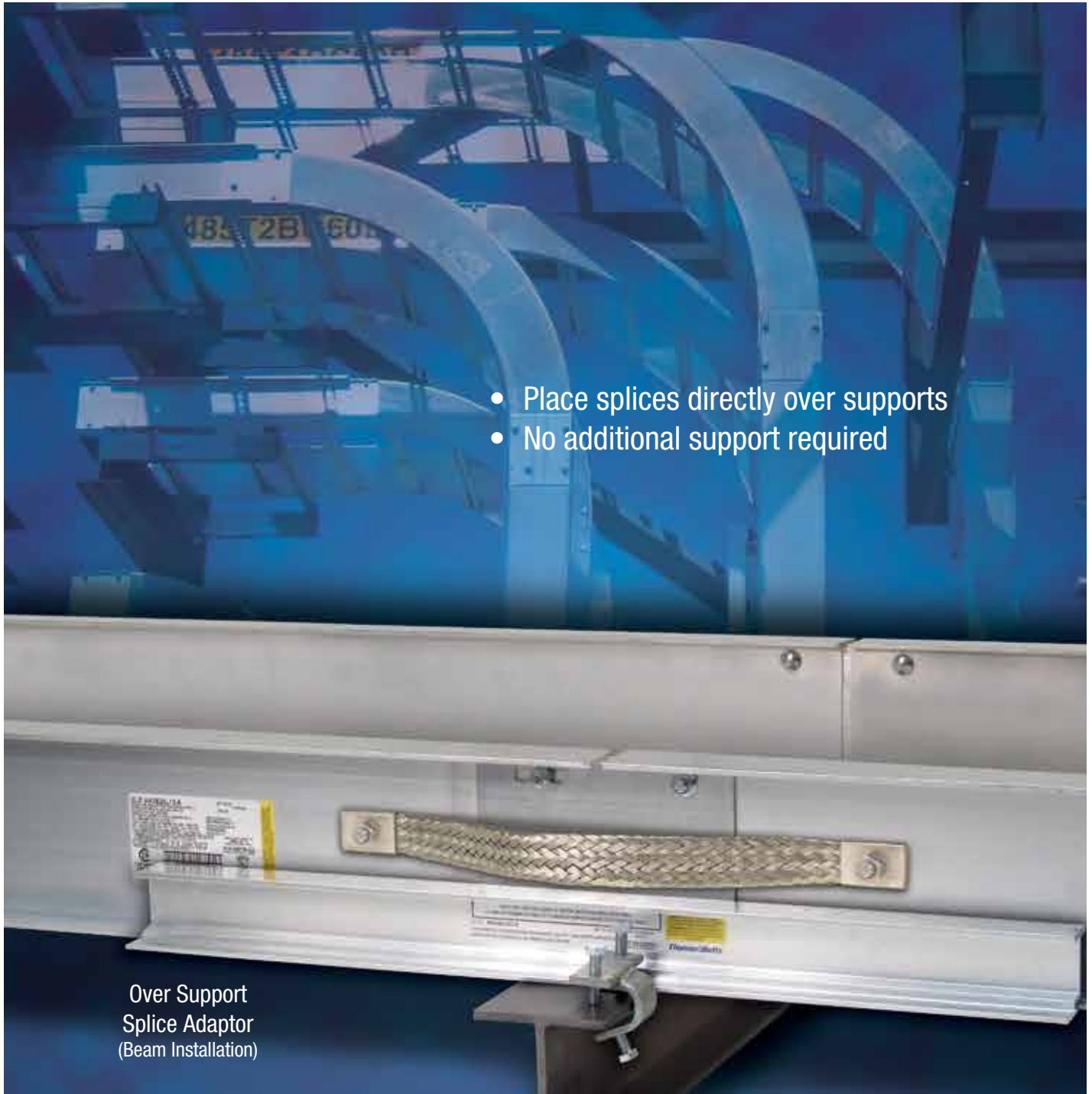

- Place splices directly over supports
- No additional support required

Over Support
Splice Adaptor
(Beam Installation)

Splice Plates

Over Support Splice Adaptor

Standard 1/4 Span Typical Installation

Supports are placed at 1/4 span (25%).

Expansion joints need extra support at 1/2 span to prevent excessive deformation of the tray under heavy loads.

New Over Support Typical Installation

Supports are placed right under the joints of the installation.

The splice adaptor allows a wider distribution of the support, therefore minimizing the stress and deflection of the assembly.

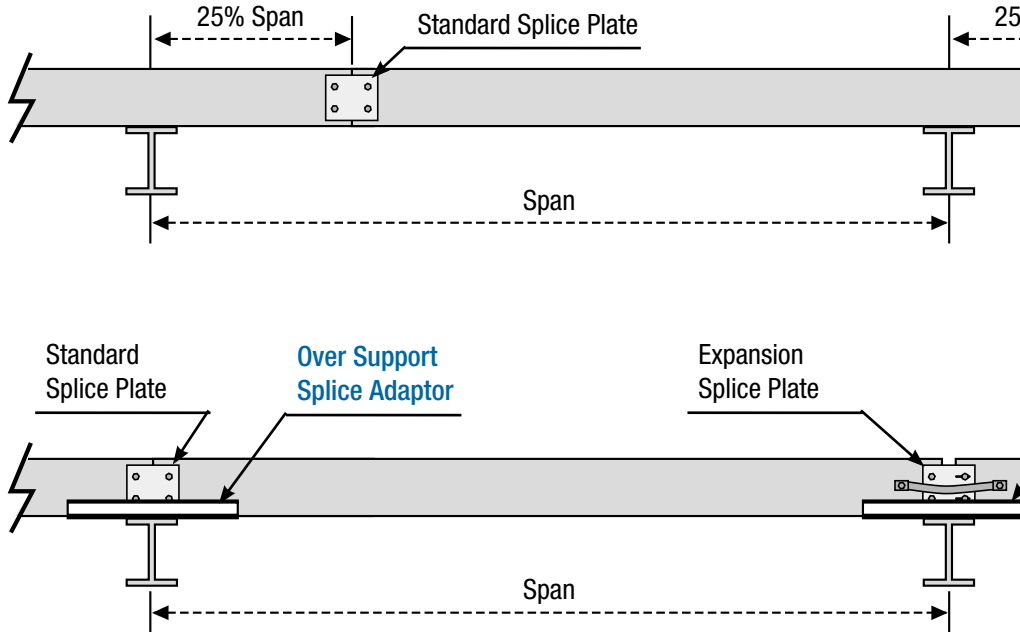

NOTE: Independent of the installation method chosen, AU/AH46 straight sections are CSA approved for Class E loading. (100%)

Over Support Splice Adaptor

Beam Installation – ABW46-OSS-B

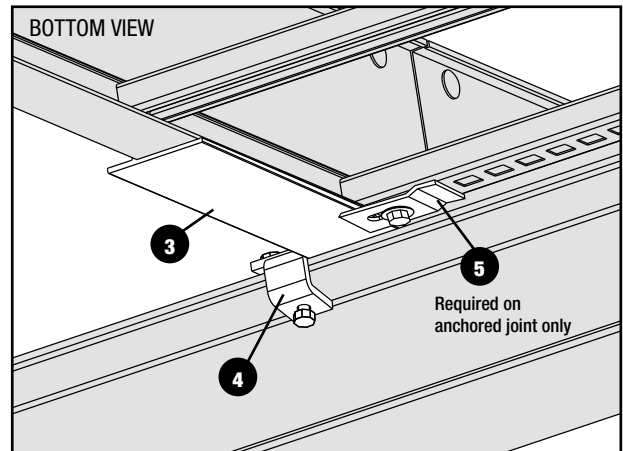
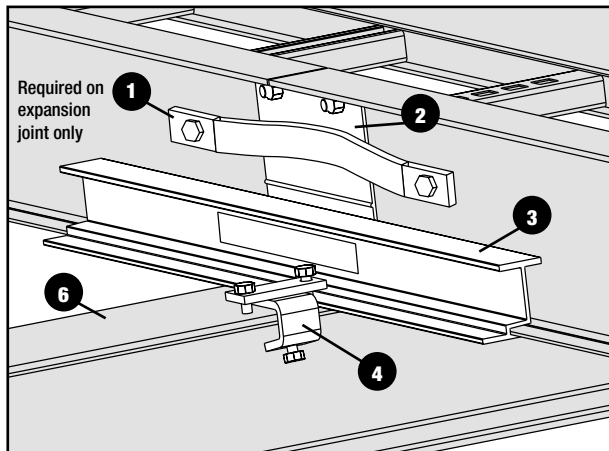

Installation Components

- | | |
|--------------------------------|---------------------------|
| 1. Bonding jumper | 5. Hold down clamp |
| 2. Splice plate | 6. Structural beam |
| 3. Over support splice adaptor | 7. Strut (see right page) |
| 4. Beam clamp | |

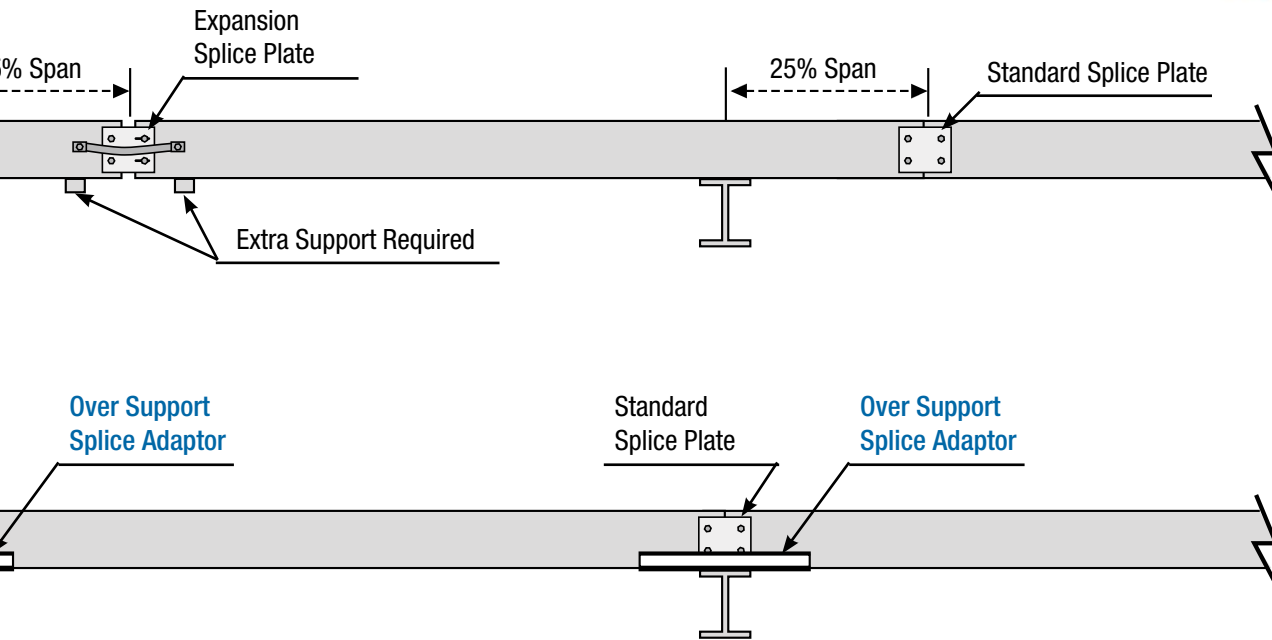

NEMA VE2: Splice joints should be designed and placed so as to maximize the rigidity of the cable tray over support. Splice plates and adaptors are part of a system specifically designed for placement directly over supports.

Over Support Splice Adaptor

Strut Installation – ABW46-OSS-S

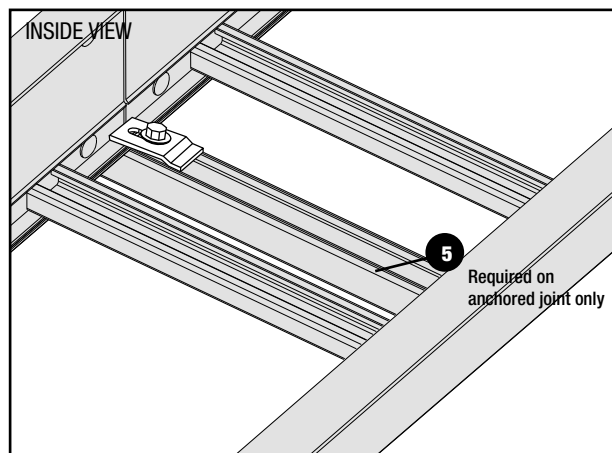
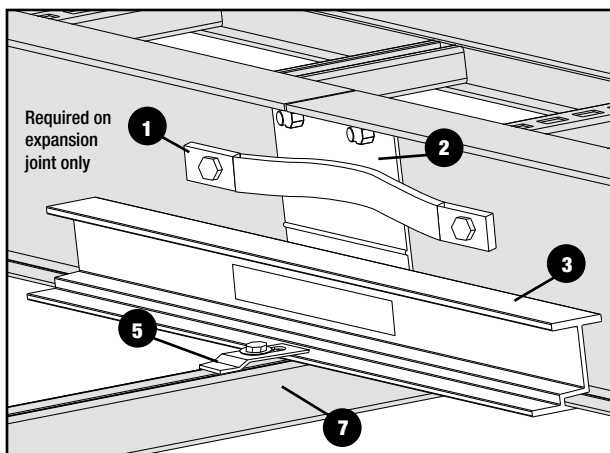

Cable Tray Installation

- Every second splice must be an expansion joint.
- For gap setting at expansion joint, refer to NEMA chart on next page.
- For use with T&B Cable Tray series AH46.
- Max. load of 80 lb/ft, 20 ft. span.
- Every joint must have a pair of over support splice adaptors (both standard splices and expansion splices)

Splice Plates

Over Support Splice Adaptor

ABW46-OSS-B

Over Support Splice Adaptor –
Beam Installation

Expansion over support beam 29 in.
SHW-CTC, Heavy-Duty hold down clamp (complete with mounting hardware)
SHW-HEC, Standard hold down clamp
E142-3/8x100EG, 3/8 in. - 16 x 1 in. hex cap screws
AC100-3/8EGC, 3/8 in. strut nut

NOTE: Every expansion joint requires the use of a bonding jumper such as FBD16-1 (16 in., 600 amps)

ABW46-OSS-S

Over Support Splice Adaptor –
Strut Installation

Expansion over support beam 29 in.
SHW-HEC, Standard hold down clamp
E142-3/8x100EG, 3/8 in. - 16 x 1 in. hex cap screws
AC100-3/8EGC, 3/8 in. strut nut

NOTE: Every expansion joint requires the use of a bonding jumper such as FBD16-1 (16 in., 600 amps)

Expansion Plate Gap Chart

