



Spectrum Research & Testing Lab., Inc.
No. 101-10, Ling 8,
Shan-Tong Li, Chung-Li
City, Taoyuan, Taiwan,
R.O.C.

TEST REPORT

Reference No.: A07012402
Report No.: EMCA06051501-01
Page: 1 of 38
Date: Jan. 24, 2007.

Product Name: ExpressCard /34
Model No.: EK-103, EK-104, EK-105, EK-108, EK-110, EK-202
Applicant: LyCOM Technology Inc.
4F-3, No. 48, BAU-CHIAU RD., HSIN-TIEN, TAIPEI HSIEN,
TAIWAN, R.O.C.
Date of Receipt: Apr. 20, 2006
Finished date of Test: May 17, 2006
Applicable Standards:

Emission

EN 55022:1998+A1:2000+A2:2003, Class B

Immunity

EN55024:1998+A1:2001+A2:2003

- IEC 61000-4-2:1995+A1:1998+A2:2001
- IEC 61000-4-3:1995+A1:1998+A2:2002
- IEC 61000-4-4:2004
- IEC 61000-4-6:2004
- IEC 61000-4-8:2001

We, **Spectrum Research & Testing Laboratory Inc.**, hereby certify that one sample of the above was tested in our laboratory with positive results according to the above-mentioned standards. The records in the report are an accurate account of the results. Details of the results are given in the subsequent pages of this report.

This report compared to original Report No.: EMCA06051501 issued on May 17, 2006 differs in Applicant. We regard it as a serial report and quote original all test data.

Checked By : Stanley Chung , Date: Jan. 24. 2007
(Stanley Chung)

Approved By : Johnson Ho , Date: 1/24/2007
(Johnson Ho, Director)

NVLAP

Lab Code: 200099-0



Table of Contents

1.	DOCUMENT POLICY AND TEST STATEMENT	4
1.1	DOCUMENT POLICY	4
1.2	TEST STATEMENT	4
1.3	EUT MODIFICATION	4
2.	DESCRIPTION OF EUT AND TEST MODE.....	5
2.1	GENERAL DESCRIPTION OF EUT	5
2.2	DESCRIPTION OF EUT INTERNAL DEVICE.....	5
2.3	DESCRIPTION OF TEST MODE.....	5
3.	DESCRIPTION OF APPLIED STANDARDS	6
4.	EMISSION TEST.....	7
4.1	CONDUCTED EMISSION TEST FOR MAIN PORT	7
4.1.1	CONDUCTED EMISSION LIMIT	7
4.1.2	TEST EQUIPMENT	7
4.1.3	TEST SETUP.....	8
4.1.4	TEST PROCEDURE.....	8
4.1.5	DESCRIPTION OF SUPPORT UNIT	9
4.1.6	EUT OPERATING CONDITION.....	9
4.1.7	TEST RESULT	10
4.2	RADIATED EMISSION TEST.....	11
4.2.1	RADIATED EMISSION LIMIT	11
4.2.2	TEST EQUIPMENT	11
4.2.3	TEST SET-UP.....	12
4.2.4	TEST PROCEDURE.....	12
4.2.5	DESCRIPTION OF SUPPORT UNIT.....	13
4.2.6	EUT OPERATING CONDITION.....	13
4.2.7	TEST RESULT	14
5.	ELECTROSTATIC DISCHARGE IMMUNITY TEST	15
5.1	TEST EQUIPMENT.....	15
5.2	TEST PROCEDURE	15
5.3	TEST SET-UP.....	16
5.4	DESCRIPTION OF SUPPORT UNIT	17
5.5	EUT OPERATING CONDITION.....	17
5.6	TEST CONDITION AND PERFORMANCE CRITERION	17
5.7	SUMMARY OF TEST RESULT	18
6.	RADIATED IMMUNITY TEST	19
6.1	TEST EQUIPMENT.....	19
6.2	TEST PROCEDURE	20
6.3	TEST SETUP	21
6.4	DESCRIPTION OF SUPPORT UNIT	22
6.5	EUT OPERATING CONDITION.....	22
6.6	TEST CONDITION / PERFORMANCE CRITERIA	22
6.7	TEST RESULT	23
7.	ELECTRICAL FAST TRANSIENT / BURST IMMUNITY TEST	24



7.1	TEST EQUIPMENT	24
7.2	TEST PROCEDURE	24
7.3	TEST SET-UP	25
7.4	DESCRIPTION OF SUPPORT UNIT	25
7.5	EUT OPERATING CONDITION	25
7.6	TEST CONDITION / PERFORMANCE CRITERIA	26
7.7	SUMMARY OF TEST RESULT	27
8.	INDUCED RF FIELDS (CONDUCTED SUSCEPTIBILITY) TEST	28
8.1	TEST EQUIPMENT	28
8.2	TEST PROCEDURE	29
8.3	TEST SET-UP	29
8.4	DESCRIPTION OF SUPPORT UNIT	29
8.5	EUT OPERATING CONDITION	29
8.6	TEST CONDITION / PERFORMANCE CRITERIA	30
8.7	SUMMARY OF TEST RESULT	30
9.	POWER FREQUENCY MAGNETIC-FIELD TEST	31
9.1	TEST EQUIPMENT	31
9.2	TEST PROCEDURE	31
9.3	TEST SET-UP	31
9.4	DESCRIPTION OF SUPPORT UNIT	31
9.5	EUT OPERATING CONDITION	32
9.6	TEST CONDITION / PERFORMANCE CRITERIA	32
9.7	SUMMARY OF TEST RESULT	32
10.1	PHOTOS OF TESTING	33
11.	TERMS OF ABBREVIATION	38



1. DOCUMENT POLICY AND TEST STATEMENT

1.1 DOCUMENT POLICY

- The report shall not be reproduced except in full, without the written approval of SRT Lab, Inc.
- The report must not be used by the applicant to claim that the product is endorsed by NVLAP, TÜV, NEMKO and SRT.
- The NVLAP logo applies only to the applicable standards specified in this report.

1.2 TEST STATEMENT

- The test results in the report apply only to the unit tested by SRT Lab.
- There was no deviation from the requirements of test standards during the test.
- AC power source, 230 VAC/50 Hz, was used during the test.
- The EN 61000-3-2 edition 2:2000(Harmonic test) and EN 61000-3-3:1995+A1:2001 (Flicker test) are not included in the scope of NVLAP logo usage.
- The EN 61000-3-2 edition 2:2000(Harmonic test) and EN 61000-3-3:1995+A1:2001 (Flicker test) are included in the scope of TÜV, NEMKO and SRT logo usage.

1.3 EUT MODIFICATION

- No modification in SRT Lab.



2. DESCRIPTION OF EUT AND TEST MODE

2.1 GENERAL DESCRIPTION OF EUT

PRODUCT	ExpressCard /34
MODEL NO.	EK-103,EK-104,EK-105,EK-108,EK-110,EK-202
POWER SUPPLY	DC from PC
CABLE	N/A
TYPE	Prototype

NOTE :

The EUT has eight model numbers as below on market. They are identical in all aspects except for the software.

For more detailed information, please refer to the EUT's specification or user's manual provided by manufacturer.

2.2 DESCRIPTION OF EUT INTERNAL DEVICE

DEVICE	BRAND / MAKER	MODEL #	REMARK
N/A			

NOTE :

1. The highest clock is 25MHz.
2. Frequency range to be measured.
Radiated emission is 30 MHz to 1 GHz.

2.3 DESCRIPTION OF TEST MODE

N/A (It is only applicable to more than one test mode.)



3. DESCRIPTION OF APPLIED STANDARDS

The EUT is a kind of ITE interface device and according to the specifications provided by the applicant, it must comply with the requirements of the following standards:

EN 55022:1998+A1:2000+A2:2003, Class B

EN 55024:1998+A1:2001+A2:2003

- IEC 61000-4-2:1995+A1:1998+A2:2001
- IEC 61000-4-3:1995+A1:1998+A2:2002
- IEC 61000-4-4:2004
- IEC 61000-4-6:2004
- IEC 61000-4-8:2001

But the standards of EN 61000-3-2, EN 61000-3-3, IEC 61000-4-5 and IEC 61000-4-11 were not measured, because the EUT's power source is DC from PC.

All tests have been performed and recorded as the above standards.



4. EMISSION TEST

4.1 CONDUCTED EMISSION TEST FOR MAIN PORT

4.1.1 CONDUCTED EMISSION LIMIT

FREQUENCY (MHz)	Class A (dB μ V)		Class B (dB μ V)	
	Quasi-peak	Average	Quasi-peak	Average
0.15 - 0.5	79	66	66 - 56	56 - 46
0.5 - 5.0	73	60	56	46
5.0 - 30.0	73	60	60	50

NOTE:

1. The lower limit shall apply at the transition frequencies.
2. The limit decreases in line with the logarithm of the frequency in the range of 0.15 to 0.50 MHz.

4.1.2 TEST EQUIPMENT

The following test equipment was used for the test:

EQUIPMENT/ FACILITIES	SPECIFICATIONS	MANUFACTURER	MODEL#/ SERIAL#	DUE DATE OF CAL. & CAL. CENTER
EMI TEST RECEIVER	9 kHz TO 30 MHz	ROHDE & SCHWARZ	ESHS30/ 826003/008	AUG. 2006 ETC
LISN (for EUT)	50 μ H, 50 ohm	FCC	FCC-LISN-50-25-2 / 01017	NOV. 2006 ETC
LISN (for Peripheral)	50 μ H, 50 ohm	FCC	FCC-LISN-50-25-2 / 01018	OCT. 2006 ETC
50 ohm TERMINATOR	50 ohm	HP	11593A/ 2	OCT. 2006 ETC
COAXIAL CABLE	5m	SUNCITY	CABLE/#5-5M	JUL. 2006 SRT
ISOLATION TRANSFORMER	N/A	APC	AFC-11015/ F102040016	N/A
FILTER	2 LINE, 30A	FIL.COIL	FC-943/ 771	N/A
GROUND PLANE	2.3M (H) x 2.4M (W)	SRT	N/A	N/A
GROUND PLANE	2.4M (H) x 2.4M (W)	SRT	N/A	N/A

NOTE: The calibration interval of the above test equipment is one year and the calibrations are traceable to NML/ROC and NIST/USA.



4.1.3 TEST SETUP

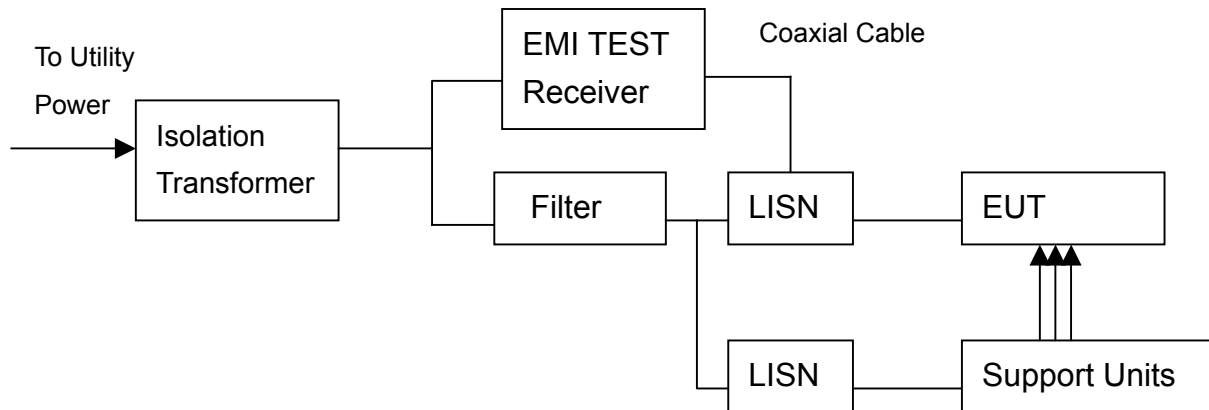

NOTE:

1. The EUT was put on a wooden table with 0.8m height above ground plane, and 0.4m away from reference ground plane (> 2mx2m).
2. For the actual test configuration, please refer to the photos of testing.
3. The serial no. of the LISN connected to EUT is 01017.
4. The serial no. of the LISN connected to support units is 01018.

4.1.4 TEST PROCEDURE

The EUT was tested according to the requirement of EN 55022:1998+A1:2000+A2:2003. The frequency spectrum from 0.15 MHz to 30 MHz was investigated. The LISN used was 50Ω/50μH as specified. All readings were quasi-peak and average values with 10 kHz resolution bandwidth of the test receiver. The EUT system was operated in all typical methods by users. Both lines of the power mains of EUT were measured and the cables connected to EUT and support units were moved to find the maximum emission levels for each frequency.

First, find the margin or higher points at least 6 points by software, then use manual to find the maximum data. The procedure is referred on the test procedure of SRT LAB.



4.1.5 DESCRIPTION OF SUPPORT UNIT

The EUT was configured by the requirement of EN 55022:1998+A1:2000+A2:2003. All interface ports were connected to the appropriate support units via specific cables. The support units and cables are listed below.

NO	DEVICE	BRAND	MODEL #	CABLE
1	PC	ACER	AS-T650-	1.8m unshielded power cord
2	MONITOR	SAMSUNG	PG17IS	1.5m unshielded power cord 1.2m shielded data cable
3	SATA HDD	VANTEC	NEXSTAR.3	3.0m unshielded power cord 1.0m unshielded data cable
4	PRINTER	EPSON	STYLUS C20SX	1.5m unshielded power cord 1.5m shielded data cable
5	MODEM	ACEEX	DM-1414	1.8m unshielded DC power cable 1.5m shielded data cable
6	KEYBOARD	IBM	SK-8820	1.5m unshielded data cable
7	MOUSE	IBM	MU29J	1.5m unshielded data cable

NOTE: For the actual test configuration, please refer to the photos of testing.

4.1.6 EUT OPERATING CONDITION

1. Under Windows XP ran "EMITEST" and "XCOPY" programs.
2. EUT sent "H" pattern or accessed the following peripherals directly:
 - Color Monitor
 - RS232
 - Keyboard
 - Mouse
 - Printer
 - FDD
 - HDD
3. XCOPY
:loop
XCOPY C:\test E:\Vs/y
Go to loop



4.1.7 TEST RESULT

Temperature:	25°C	Humidity:	87%RH
Ferquency Range:	0.15 – 30 MHz	Tested Mode:	N/A
Receiver Detector:	Q.P. and AV.	Tested By:	Sunyou Chen
		Tested Date:	May 15, 2006

Power Line Measured : Line

Freq. (MHz)	Correct. Factor (dB)	Reading Value (dB μ V)		Emission Level (dB μ V)		Limit (dB μ V)		Margin (dB)	
		Q.P.	AV.	Q.P.	AV.	Q.P.	AV.	Q.P.	AV.
0.477	0.25	41.20	40.89	41.45	41.14	56.39	46.39	-14.94	-5.25
0.480	0.25	41.02	40.47	41.27	40.72	56.34	46.34	-15.07	-5.62
0.682	0.22	35.72	32.18	35.94	32.40	56.00	46.00	-20.06	-13.60
1.230	0.14	32.92	31.65	33.06	31.79	56.00	46.00	-22.94	-14.21
2.804	0.18	31.20	26.68	31.38	26.86	56.00	46.00	-24.62	-19.14
9.628	0.23	33.46	29.93	33.69	30.16	60.00	50.00	-26.31	-19.84

Power Line Measured : Neutral

Freq. (MHz)	Correct. Factor (dB)	Reading Value (dB μ V)		Emission Level (dB μ V)		Limit (dB μ V)		Margin (dB)	
		Q.P.	AV.	Q.P.	AV.	Q.P.	AV.	Q.P.	AV.
0.477	0.25	45.26	45.21	45.51	45.46	56.39	46.39	-10.88	-0.93
0.480	0.25	45.04	44.91	45.29	45.16	56.34	46.34	-11.05	-1.18
0.682	0.22	38.52	35.26	38.74	35.48	56.00	46.00	-17.26	-10.52
1.438	0.15	37.44	35.15	37.59	35.30	56.00	46.00	-18.41	-10.70
2.734	0.17	37.68	32.11	37.85	32.28	56.00	46.00	-18.15	-13.72
8.126	0.23	36.70	33.78	36.93	34.01	60.00	50.00	-23.07	-15.99

NOTE :

1. Measurement uncertainty is +/-1.32dB
2. Emission level = Reading value + Correction factor
3. Correction Factor = Cable loss + Insertion loss of LISN
4. Margin value = Emission level - Limit
5. The emission of other frequencies were very low against the limit.
6. "-": The Quasi-peak reading value also meets average limit and measurement with the average detector is unnecessary.



4.2 RADIATED EMISSION TEST

4.2.1 RADIATED EMISSION LIMIT

EN 55022:1998+A1:2000+A2:2003 limits of radiated emission measurement for frequency below 1000 MHz

FREQUENCY (MHz)	Class A (at 10m)	Class B (at 10m)
	dB μ V/m	dB μ V/m
30 – 230	40	30
230 - 1000	47	37

NOTE:

1. The lower limit shall apply at the transition frequencies.
2. Emission level (dB μ V/m) = 20 log Emission level (μ V/m).

4.2.2 TEST EQUIPMENT

The following test equipment was used during the radiated emission test:

EQUIPMENT/ FACILITIES	SPECIFICATIONS	MANUFACTURER	MODEL#/ SERIAL#	DUE DATE OF CAL. & CAL. CENTER
EMI TEST RECEIVER	9 kHz TO 2.75 GHz	ROHDE & SCHWARZ	ESCS30/ 830245/012	OCT. 2006 ETC
BI-LOG ANTENNA	25 MHz TO 2 GHz	EMCO	3143/ 9509-1141	OCT. 2006 SRT
OATS	3 – 10 M MEASUREMENT	SRT	SRT-1	DEC. 2006 SRT
COAXIAL CABLE	25M	SUNCITY	J400-25M-2NP/ #153-25M	JUN. 2006 SRT
FILTER	2 LINE, 30A	FIL.COIL	FC-943/ 869	N/A
FREQUENCY CONVERTER	N/A	APC	AFC-2KBB/ F100030031	AUG. 2006 SRT

NOTE:

1. The calibration interval of the above test equipment is one year and the calibrations are traceable to NML/ROC and NIST/USA.
2. The Open Area Test Site (SRT-1) is registered by FCC with No. 90957 and VCCI with No. R-1081.
3. The Open Area Test Site (SRT-2) is registered by FCC with No. 98458 and VCCI with No. R-1168.



4.2.3 TEST SET-UP

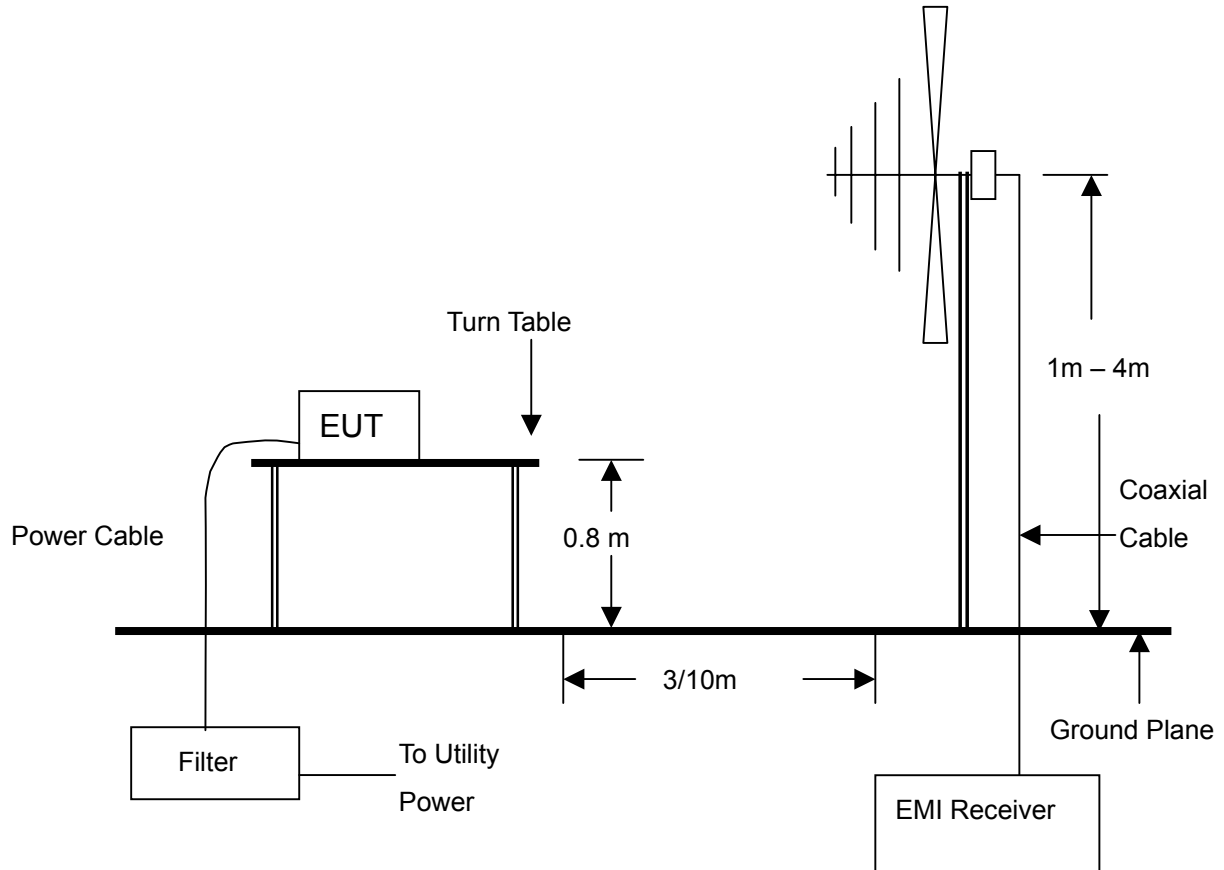

NOTE:

1. The EUT system was put on a wooden table with 0.8m heights above a ground plane.
2. For the actual test configuration, please refer to the photos of testing.

4.2.4 TEST PROCEDURE

The EUT was tested according to the requirement of EN 55022:1998+A1:2000+A2:2003. The measurements were made at an open area test site with 10 meter measurement distance. The frequency spectrum measured from 30 MHz to 1 GHz. All readings were quasi-peak values with 120 kHz resolution bandwidth of the test receiver. The EUT system was operated in all typical methods by users. The cables connected to EUT and support units were moved to find the maximum emission levels for each frequency. First, find the margin or higher points at least 6 points by software, then use manual to find the maximum data. The procedure is referred on the test procedure of SRT LAB.



**Spectrum Research &
Testing Lab., Inc.**
No. 101-10, Ling 8,
Shan-Tong Li, Chung-Li
City, Taoyuan, Taiwan,
R.O.C.

TEST REPORT

Reference No.: A07012402
Report No.:EMCA06051501-01
Page:13 of 38
Date: Jan. 24, 2007.

4.2.5 DESCRIPTION OF SUPPORT UNIT

Same as section 4.1.5 of this report.

4.2.6 EUT OPERATING CONDITION

Same as section 4.1.6 of this report.



4.2.7 TEST RESULT

Temperature:	25 °C	Humidity:	87 %RH
Ferquency Range:	0.15 – 30 MHz	Tested Mode:	N/A
Receiver Detector:	Q.P. and AV.	Tested By:	Sunyou Chen
		Tested Date:	May 05, 2006

Antenna Polarization: Horizontal

Frequency (MHz)	Cable Loss (dB)	Antenna Factor (dB)	Reading Data (dBμV)	Emission Level (dBμV/m)	Limit (dBμV/m)	Margin (dB)	AZ(°)	EL(m)
0.477	0.25	45.30	44.95	45.55	45.20	56.39	46.39	-10.84
0.480	0.25	45.02	44.49	45.27	44.74	56.34	46.34	-11.07
1.162	0.14	38.68	37.06	38.82	37.20	56.00	46.00	-17.18
2.665	0.17	39.56	36.90	39.73	37.07	56.00	46.00	-16.27
2.804	0.18	36.08	33.18	36.26	33.36	56.00	46.00	-19.74
11.268	0.23	35.94	30.25	36.17	30.48	60.00	50.00	-23.83

Antenna Polarization:Vertical

Frequency (MHz)	Cable Loss (dB)	Antenna Factor (dB)	Reading Data (dBμV)	Emission Level (dBμV/m)	Limit (dBμV/m)	Margin (dB)	AZ(°)	EL(m)
0.477	0.25	45.50	44.91	45.75	45.16	56.39	46.39	-10.64
0.480	0.25	45.30	44.49	45.55	44.74	56.34	46.34	-10.79
1.162	0.14	39.06	37.14	39.20	37.28	56.00	46.00	-16.80
2.665	0.17	39.72	36.74	39.89	36.91	56.00	46.00	-16.11
8.471	0.23	37.74	31.97	37.97	32.20	60.00	50.00	-22.03
9.222	0.23	38.54	34.89	38.77	35.12	60.00	50.00	-21.23

NOTE :

1. Measurement uncertainty is +/-2dB.
2. "": Measurement does not apply for this frequency.
3. Emission Level = Reading Value + Ant. Factor + Cable Loss.
4. The field strength of other emission frequencies were very low against the limit.



Spectrum Research & Testing Lab., Inc.
No. 101-10, Ling 8,
Shan-Tong Li, Chung-Li
City, Taoyuan, Taiwan,
R.O.C.

TEST REPORT

Reference No.: A07012402
Report No.:EMCA06051501-01
Page:15 of 38
Date: Jan. 24, 2007.

5. ELECTROSTATIC DISCHARGE IMMUNITY TEST

5.1 TEST EQUIPMENT

EQUIPMENT / FACILITIES	MANUFACTURER	MODEL # / SERIAL #	DUE DATE OF CAL. & CAL. CENTER
ESD SIMULATOR	NOISEKEN	ESS-100L(A)/TC-815P/ 8099C02238/7099C02	OCT. 2006 ETC
HCP (1.6M x 0.8M)	SRT	WITH TWO 470k OHM CABLE	N/A
VCP (0.5M x 0.5M)	SRT	WITH TWO 470k OHM CABLE	N/A
GROUND PLANE (3.4M x 2.4M)	SRT	N/A	N/A

NOTE: The calibration interval of the above test equipment is one year and the calibrations are traceable to NML/ROC and NIST/USA.

5.2 TEST PROCEDURE

According to IEC/EN 61000-4-2:1995+A1:1998+A2:2001

5.3 TEST SET-UP

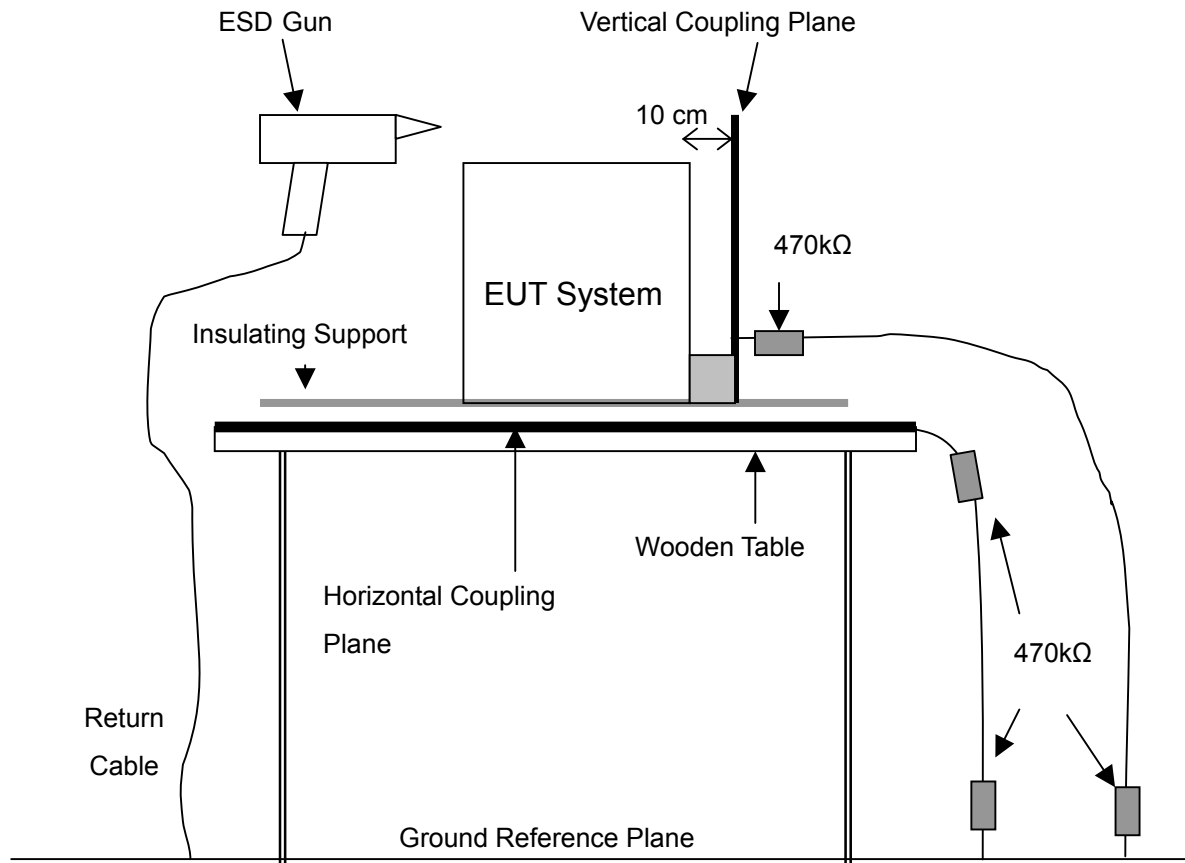

NOTE :

1. The wooden table should be 0.8m high for table top EUT and 0.1m for floor-standing EUT.
2. For the actual test configuration, please refer to the photos of testing.
3. A distance of 1m minimum was provided between EUT and walls / other metallic structure.



5.4 DESCRIPTION OF SUPPORT UNIT

Same as section 4.1.5 of this report.

5.5 EUT OPERATING CONDITION

Same as section 4.1.6 of this report.

5.6 TEST CONDITION AND PERFORMANCE CRITERION

1. Test condition

- (1) R-C Network : 330 Ω , 150 pF
- (2) Test level: Air Discharge : ± 2 kV, ± 4 kV, ± 8 kV
 - Contact discharge : ± 2 kV, ± 4 kV
 - HCP discharge : ± 2 kV, ± 4 kV
 - VCP discharge : ± 2 kV, ± 4 kV
- (3) Discharge mode : Single discharge
- (4) Discharge period : at least 1 s
- (5) Discharge polarity : Positive and Negative
- (6) Number of discharge : Minimum 50 times at each test point of contact discharge and at least 200 times of discharge to EUT in total. Minimum 10 times at each test area of air discharge selected.

- 2. Standard requirement : Criterion B

3. Performance criterion

- (1) Criterion A : Normal performance during test
- (2) Criterion B : Temporary degradation or loss of function or performance which is self-recoverable
- (3) Criterion C : Temporary degradation or loss of function or performance which requires operator intervention system reset



5.7 SUMMARY OF TEST RESULT

Temperature:	<u>23°C</u>	Humidity:	<u>50% RH</u>
Tested Mode:	<u>N/A</u>	Tested By:	<u>Sunyou Chen</u>
Atmospheric Air Pressure:	<u>101.2kPa</u>	Tested Date:	<u>May 15, 2006</u>

Test Result: Criterion B pass

SEVERITY LEVEL	COUPLING MODE & TEST OBSERVATION			
	AIR DISCHARGE	CONTACT DISCHARGE	HCP	VCP
±2kV	A	B	A	A
±4kV	A	B	A	A
±8kV	A	NR	NR	NR

NOTE:

Description of test observation:

A: There was no change compared with initial operation during the test.

B: EUT was delayed when copied data during the test.

NR: No requirement

Description of test points:

1. Connector
2. LED.
3. Enclosure of EUT.
4. HCP.
5. VCP.



6. RADIATED IMMUNITY TEST

6.1 TEST EQUIPMENT

EQUIPMENT / FACILITIES	MANUFACTURER	MODEL # / SERIAL #	DUE DATE OF CAL. & CAL. CENTER
SIGNAL GENERATOR	HP	8648D/ 3847M00637	MAY. 2006 AGLIENT
ANTENNA	SCHAFFNER CHASE	CBL6141A / 4181	OCT. 2006 SRT
FIELD SENSOR	AMPLIFIER RESEARCH	FP2000/ 28499	DEC. 2006 ETC
POWER AMPLIFIER	AMPLIFIER RESEARCH	100W1000M1/ 19509	MAY 2006 ETC
AMPLIFIER	A.R.	50S1G4A/ 308703	MAY 2006 A.R.
DUAL DIRECTIONAL COUPLER	A.R.	DC7420/ 308626	MAY. 2006 ETC
ISOTROPIC "E" FIELD PROBE	A.R.	FP4080 KIT/ 308105	MAY. 2006 A.R.
POWER SENSOR	BOONTON	51011 (SE) / 32966	DEC. 2006 ETC
POWER SENSOR	BOONTON	51011 (CE) / 32964	DEC. 2006 ETC
DUAL DIRECTIONAL COUPLER	A.R.	DC6080/ 310289	NOV. 2006 ETC.
ANECHOIC CHAMBER	SRT	A05/ SRT005	OCT. 2006 SRT
V/M MONITOR	A.R.	FM2000/ 15970	N/A
MONITOR	SHIN	SI-609/ 905130	N/A
CCD	TOPVIEW	N/A/ 95113762	N/A
ABSORBER	ETS	N/A	N/A
COAXIAL CABLE	SUNCITY	LMR400/ 0.5M	AUG. 2006 SRT
COAXIAL CABLE	SUNCITY	J400-12M-NP	MAY. 2006 SRT

NOTE: The calibration interval of the above test equipment is one year and the calibrations are traceable to NML/ROC and NIST/USA.



**Spectrum Research &
Testing Lab., Inc.**
No. 101-10, Ling 8,
Shan-Tong Li, Chung-Li
City, Taoyuan, Taiwan,
R.O.C.

TEST REPORT

Reference No.: A07012402
Report No.:EMCA06051501-01
Page:20 of 38
Date: Jan. 24, 2007.

6.2 TEST PROCEDURE

According to IEC/EN 61000-4-3:2002+A1:2002

6.3 TEST SETUP

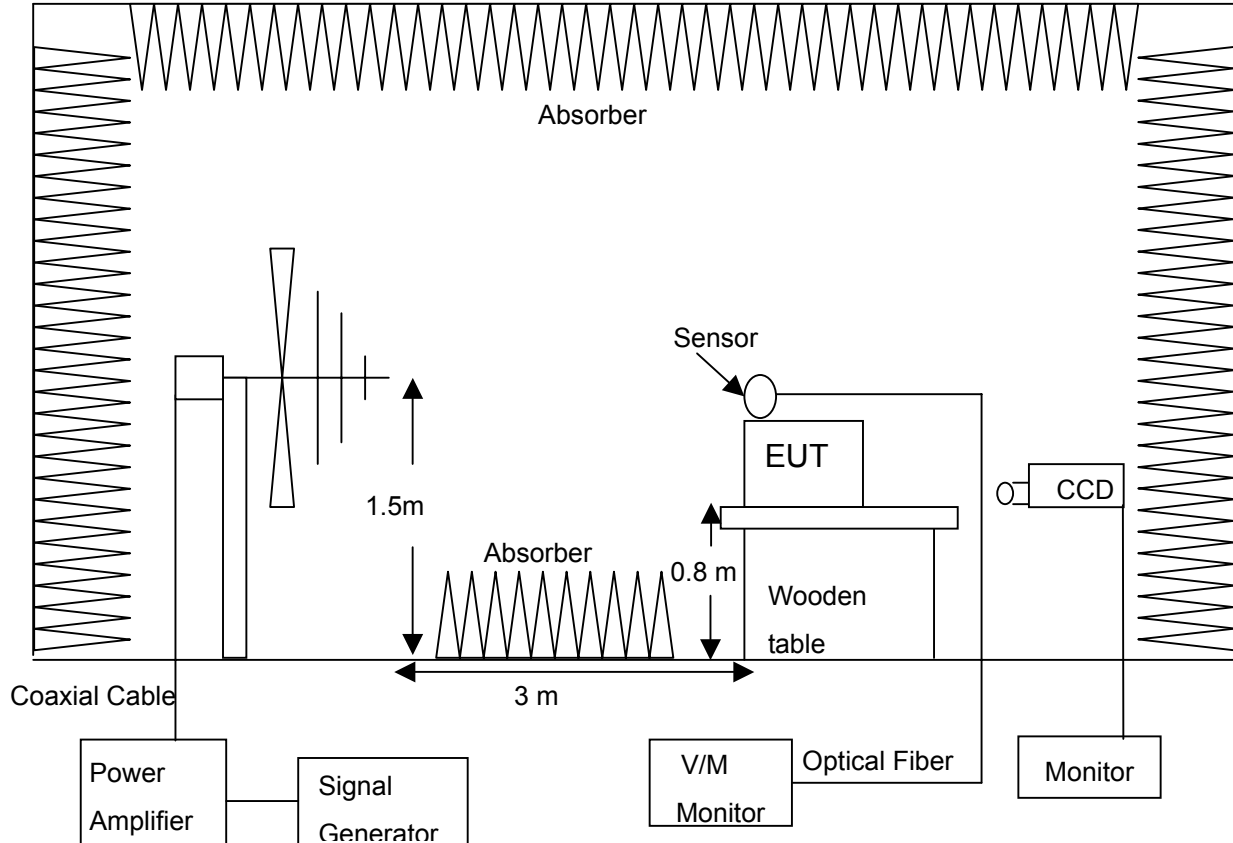

NOTE :

1. The wooden table should be 0.8m high for table top EUT and 0.1m for floor-standing EUT.
2. For the actual test configuration, please refer to the photos of testing.

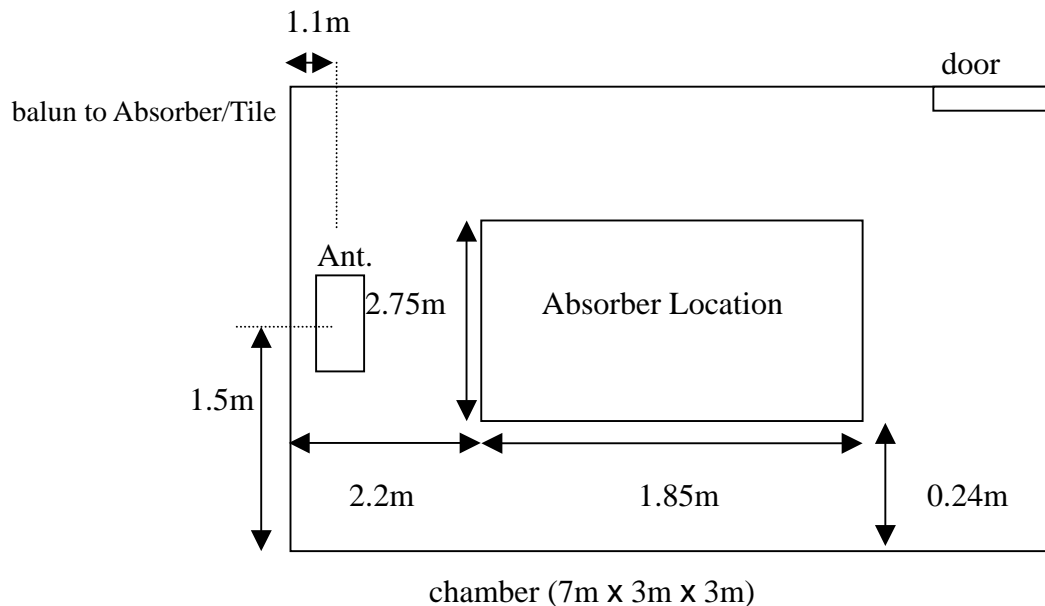



6.4 DESCRIPTION OF SUPPORT UNIT

Same as section 4.1.5 of this report.

6.5 EUT OPERATING CONDITION

Same as section 4.1.6 of this report.

6.6 TEST CONDITION / PERFORMANCE CRITERIA

1. Test condition

- (1) Source voltage and frequency : 230V/50Hz, single phase
- (2) Sweeping frequency : 80MHz – 1 GHz
- (3) Test level : 3V/m, the frequency step is 1%
- (4) The four sides of EUT are tested : front, rear, left, right
- (5) Modulation : 80%AM, 1kHz Dwell time for each frequency is 3 sec.
- (6) Antenna Polarization : Horizontal and Vertical
- (7) Standard requirement : Criterion A

2. Performance criterion

- (1) Criterion A : Normal performance during test
- (2) Criterion B : Temporary degradation or loss of function or performance which is self-recoverable.
- (3) Criterion C : Temporary degradation or loss of function or performance which requires operator intervention system reset.



Spectrum Research & Testing Lab., Inc.
No. 101-10, Ling 8,
Shan-Tong Li, Chung-Li
City, Taoyuan, Taiwan,
R.O.C.

TEST REPORT

Reference No.: A07012402
Report No.:EMCA06051501-01
Page:23 of 38
Date: Jan. 24, 2007.

6.7 TEST RESULT

Temperature: 23°C Humidity: 85% RH
Tested Mode: N/A Tested By: Sunyou Chen
Tested Date: May 15, 2006

Test Result : Criterion A pass

FREQUENCY	LEVEL	MODULATION	DIRECTION	TEST RESULT (CRITERION)	
				H	V
80MHz - 1GHz	3V/m	80%AM, 1kHz	FRONT	A	A
80MHz - 1GHz	3V/m	80%AM, 1kHz	REAR	A	A
80MHz - 1GHz	3V/m	80%AM, 1kHz	LEFT	A	A
80MHz - 1GHz	3V/m	80%AM, 1kHz	RIGHT	A	A

NOTE:

Description of test observation:

A: There was no change compared with initial operation during the test.



Spectrum Research & Testing Lab., Inc.
No. 101-10, Ling 8,
Shan-Tong Li, Chung-Li
City, Taoyuan, Taiwan,
R.O.C.

TEST REPORT

Reference No.: A07012402
Report No.:EMCA06051501-01
Page:24 of 38
Date: Jan. 24, 2007.

7. ELECTRICAL FAST TRANSIENT / BURST IMMUNITY TEST

7.1 TEST EQUIPMENT

EQUIPMENT / FACILITIES	MANUFACTURER	MODEL # / SERIAL #	DUE DATE OF CAL & CAL CENTER
EFT GENERATOR	HAEFELY	PEFT-JUNIOR / 583-333-122	MAY. 2006 ETC
CLAMP	HAEFELY	TRENCH / 080421-12	N/A
GROUND PLANE 2M x 3M	SRT	N/A	N/A

7.2 TEST PROCEDURE

According to IEC/EN 61000-4-4:1995+A1:2001+A2:2001



7.3 TEST SET-UP

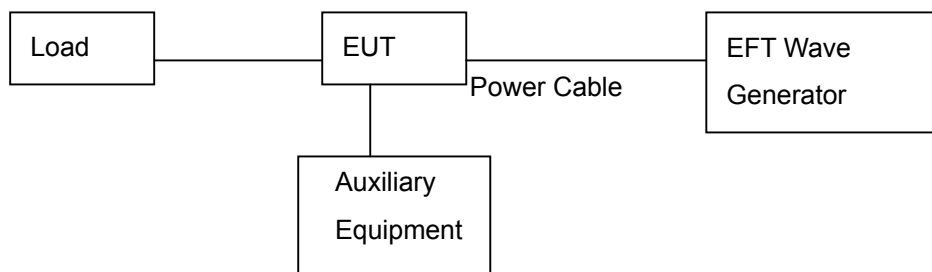
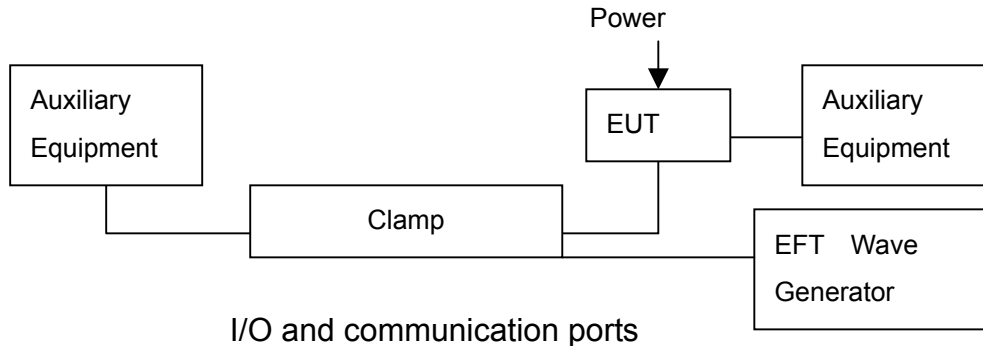

NOTE :

1. The EUT system was put on a wooden table with 0.8m height for table top EUT and 0.1m for floor-standing EUT above ground reference plane.
2. For the actual test configuration, please refer to the photos of testing.
3. The minimum distance between the EUT and all other conductive structure was more than 0.5m.
4. The minimum distance between the coupling plates of the coupling clamps (if used) and all over conductive structures, except the ground plane beneath the coupling clamp and beneath the EUT was more than 0.5m.
5. The power cable connecting EUT was controlled under 1m.

7.4 DESCRIPTION OF SUPPORT UNIT

Same as section 4.1.5 of this report.

7.5 EUT OPERATING CONDITION

Same as section 4.1.6 of this report.



7.6 TEST CONDITION / PERFORMANCE CRITERIA

1. Test condition

- (1) Source voltage and frequency : 230V/50Hz, single phase
- (2) Pulse risetime and duration : 5ns / 50ns
- (3) Pulse repetition : 5kHz
- (4) Polarity : Positive Polarization and Negative Polarization
- (5) Burst duration and period : 15ms / 300ms
- (6) Test duration : 61sec each line
- (7) Time between test : 10Sec
- (8) Severity levels : Power Line $\pm 1\text{kV}$
Signal/Control Line $\pm 0.5\text{kV}$
- (9) Standard requirement : Criterion B

2. Performance criterion

- (1) Criterion A : Normal performance during test
- (2) Criterion B : Temporary degradation or loss of function or performance which is self-recoverable.
- (3) Criterion C : Temporary degradation or loss of function or performance which requires operator intervention system reset.



Spectrum Research & Testing Lab., Inc.
No. 101-10, Ling 8,
Shan-Tong Li, Chung-Li
City, Taoyuan, Taiwan,
R.O.C.

TEST REPORT

Reference No.: A07012402
Report No.:EMCA06051501-01
Page:27 of 38
Date: Jan. 24, 2007.

7.7 SUMMARY OF TEST RESULT

Temperature:	<u>25 °C</u>	Humidity:	<u>87% RH</u>
Tested Mode:	<u>N/A</u>	Tested By:	<u>Sunyou Chen</u>
Atmospheric Air Pressure:	<u>101.2 kPa</u>	Tested Date:	<u>May 15, 2006</u>

Test Result : Criterion B pass

Voltage		1kV	
Polarity		+	-
Test Result	L1	B	B
	L2	B	B
	GND	B	B
	Signal/Control Line	N/A	N/A

NOTE:

Description of test observation:

A: There was no change compared with initial operation during the test.

B: EUT was delayed when copied data during the test.

N/A: Not applicable, as the signal/control line used in typical is less than 3 m.



8. INDUCED RF FIELDS (CONDUCTED SUSCEPTIBILITY) TEST

8.1 TEST EQUIPMENT

EQUIPMENT / FACILITIES	MANUFACTURER	MODEL # / SERIAL #	DUE DATE OF CAL. & CAL. CENTER	FINAL TEST BE USED
EM INJECTION CLAMP	FCC	F-203I-23mm/110	MAY 2006 ETC	
POWER LINE CDN	FCC	FCC-801-M5-32A/9812	MAY 2006 ETC	
POWER LINE CDN	FCC	FCC-801-M1-32A/9820	MAY 2006 ETC	
SIGNAL LINE CDN	FCC	FCC-801-T2/9830	MAY 2006 ETC	
SIGNAL LINE CDN	FCC	FCC-801-T6/9832	MAY 2006 ETC	
SIGNAL LINE CDN	FCC	FCC-801-T4/9831	AUG. 2006 ETC	
POWER LINE CDN	FCC	FCC-801-M2-32A/9840	OCT. 2006 ETC	
SIGNAL GENERATOR	R&S	SMY01/841104/019	MAY. 2006 ETC	X
POWER AMPLIFIER	A.R.	150A100A/19553	NOV. 2006 ETC	X
DUAL DIRECTION COULPER	A.R.	DC2600/25893	OCT. 2006 ETC	X
POWER METER	BOONON	4232A/105302	NOV. 2006 ETC	X
POWER SENSOR	BOONON	51011-EMC/31181	NOV. 2006 ETC	X
POWER SENSOR	BOONON	51011-EMC/31745	NOV. 2006 ETC	X
SIGNAL LINE CDN	FCC	FCC-801-S25/9845	MAY 2006 ETC	
POWER LINE CDN	FCC	FCC-801-M3-32A/9874	MAY 2006 ETC	X
T2	EM-TEST	ATT6/75/1001-40	N/A	X
COAXIAL CABLE	SUNCITY	CABLE14/#14-1M	AUG. 2006 SRT	X
COAXIAL CABLE	SUNCITY	CABLE05/#5-5M	AUG. 2006 SRT	X
COAXIAL CABLE	TIME	LMR-400/#2M	AUG. 2006 SRT	X



8.2 TEST PROCEDURE

According to IEC/EN 61000-4-6:2004

8.3 TEST SET-UP

(1) For CDN injection :

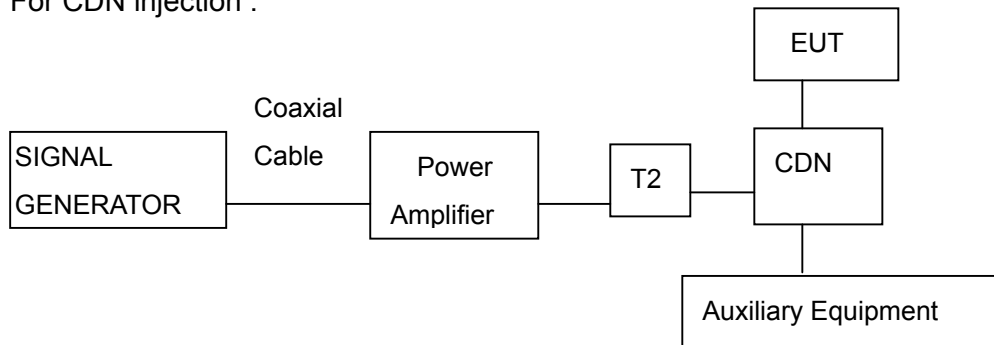

(2) For Clamp injection :

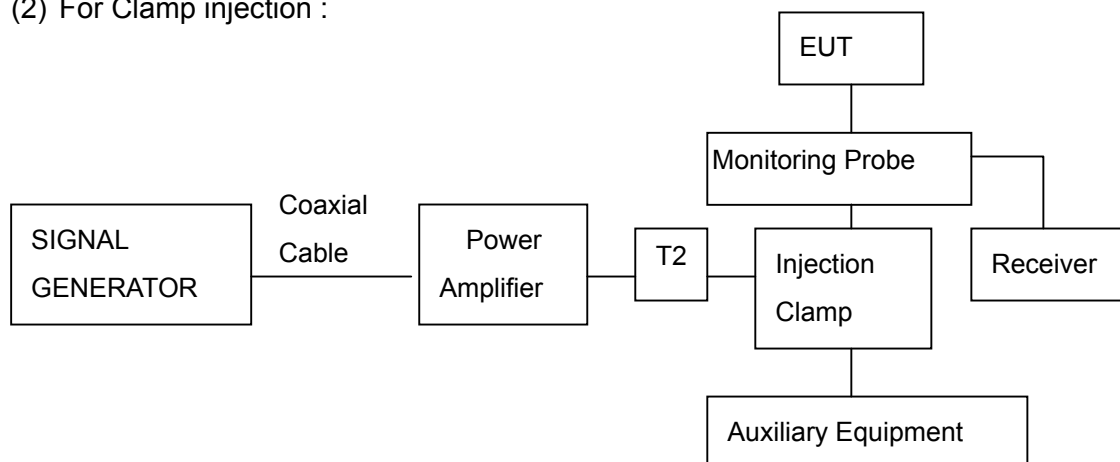

NOTE :

1. The EUT system was put on a wooden table with 0.1m height above ground.
2. For the actual test configuration, please refer to the photos of testing.
3. The distance between CDN(Clamp) and EUT was controlled between 0.1m and 0.3m.
4. The model no. of the CDN connected to EUT is FCC-801-M3-32A.

8.4 DESCRIPTION OF SUPPORT UNIT

Same as section 4.1.5 of this report.

8.5 EUT OPERATING CONDITION

Same as section 4.1.6 of this report.



8.6 TEST CONDITION / PERFORMANCE CRITERIA

1. Test condition

- (1) Source voltage and frequency : 230 V/ 50 Hz, single phase
- (2) Sweeping frequency : 150 kHz – 80 MHz
- (3) Test level : 3 V, the frequency step is 1%
- (4) Modulation : AM 80%, 1 kHz
- (5) Dwell time for each frequency : 3 sec
- (6) Standard requirement : Criterion A

2. Performance criterion

- (1) Criterion A : Normal performance during test
- (2) Criterion B : Temporary degradation or loss of function or performance which is self-recoverable
- (3) Criterion C : Temporary degradation or loss of function or performance which requires operator intervention system reset

8.7 SUMMARY OF TEST RESULT

Temperature: 25°C Humidity: 87% RH
 Tested Mode: N/A Tested By: Sunyou Chen
 Tested Date: May 15, 2006

Test Result : Criterion A pass

FREQUENCY	LEVEL	MODULATION	INJECTION METHOD	TEST RESULT (CRITERION)
150kHz - 80MHz	3V	80% AM, 1 kHz	M3	A

NOTE:

Description of test observation:

A: There was no change compared with initial operation during the test.



9. POWER FREQUENCY MAGNETIC-FIELD TEST

9.1 TEST EQUIPMENT

EQUIPMENT / FACILITIES	MANUFACTURER	MODEL # / SERIAL #	DUE DATE OF CAL. & CAL. CENTER
MAGNETIC FIELD TESTER	HAEFELY	MAG 100.1/ 080.015-04	DEC. 2006 SRT
MAGNETIC FIELD COIL	HAEFELY	MAG 100.1/ 080.015-04	DEC. 2006 SRT
MAGNETIC FIELD METER	F.W.BELL	4080/ 19990416	MAY. 2006 ITRI

9.2 TEST PROCEDURE

According to IEC/EN 61000-4-8:1993+A1:2001

9.3 TEST SET-UP

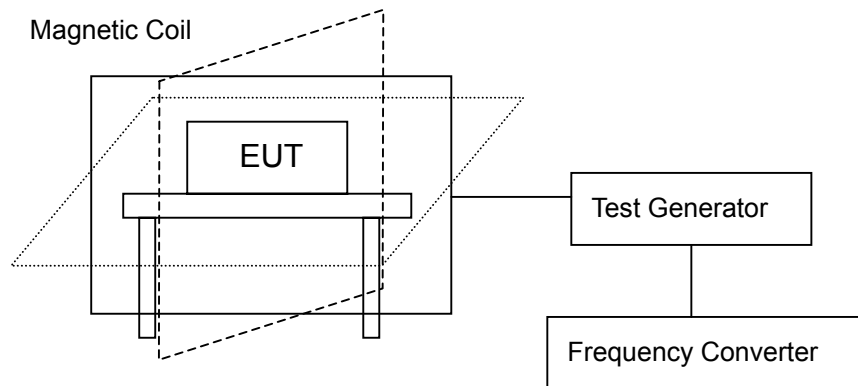

NOTE :

1. The EUT system was put on a wooden table with 0.8m height above ground.
2. For the actual test configuration, please refer to the photos of testing
3. $1A/m = 12.56mG$, $3A/m = 37.68mG$, $10A/m = 125.6mG$,

9.4 DESCRIPTION OF SUPPORT UNIT

Same as section 4.1.5 of this report.



9.5 EUT OPERATING CONDITION

Same as section 4.1.6 of this report.

9.6 TEST CONDITION / PERFORMANCE CRITERIA

1. Test condition

- (1) Test axis : X, Y and Z axes
- (2) Test time : 5 min / each axis
- (3) Field strength : 3 A/m
- (4) Standard requirement : Criterion A

2. Performance criterion

- (1) Criterion A : Normal performance during test
- (2) Criterion B : Temporary degradation or loss of function or performance which is self-recoverable
- (3) Criterion C : Temporary degradation or loss of function or performance which requires operator intervention system reset

9.7 SUMMARY OF TEST RESULT

Temperature: 25°C Humidity: 87% RH
 Tested Mode: N/A Tested By: Sunyou Chen
 Frequency of Magnetic Field: 50Hz, 60Hz Tested Date: May 15, 2006

Test Result : Criterion A pass

ORIENTATION	FIELD STRENGTH	TEST RESULT (CRITERION)
X	3 A/m	A
Y	3 A/m	A
Z	3 A/m	A

NOTE:

Description of test observation:

A: There was no change compared with initial operation during the test.



10.1 PHOTOS OF TESTING

-Conducted Emission test

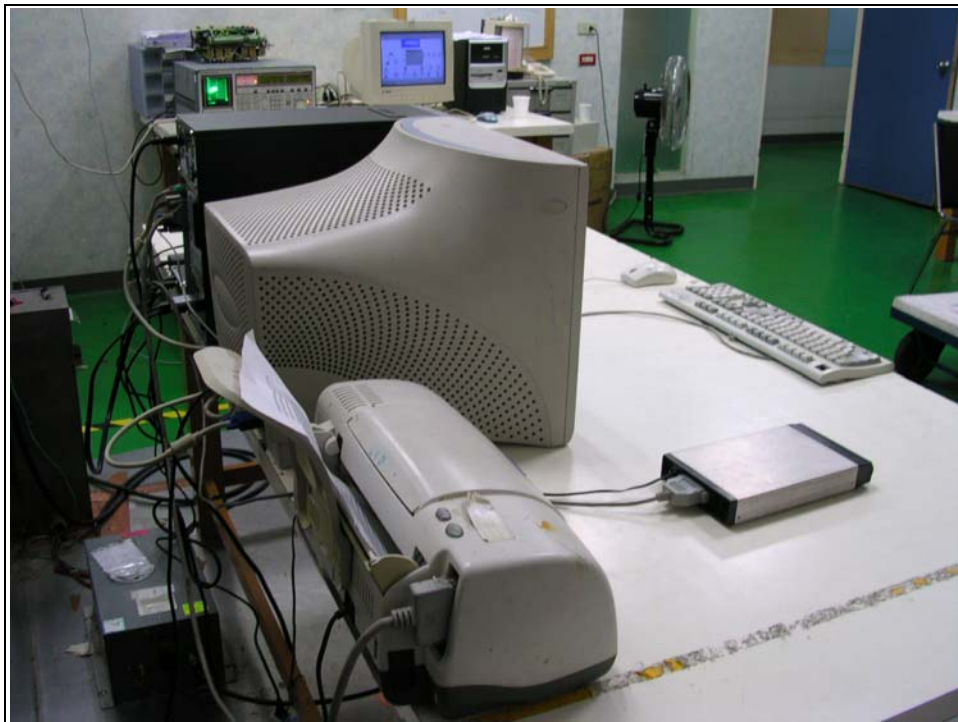



- Radiated Emission test





- Electrostatic discharge immunity test



- Electrical fast transient / burst immunity test

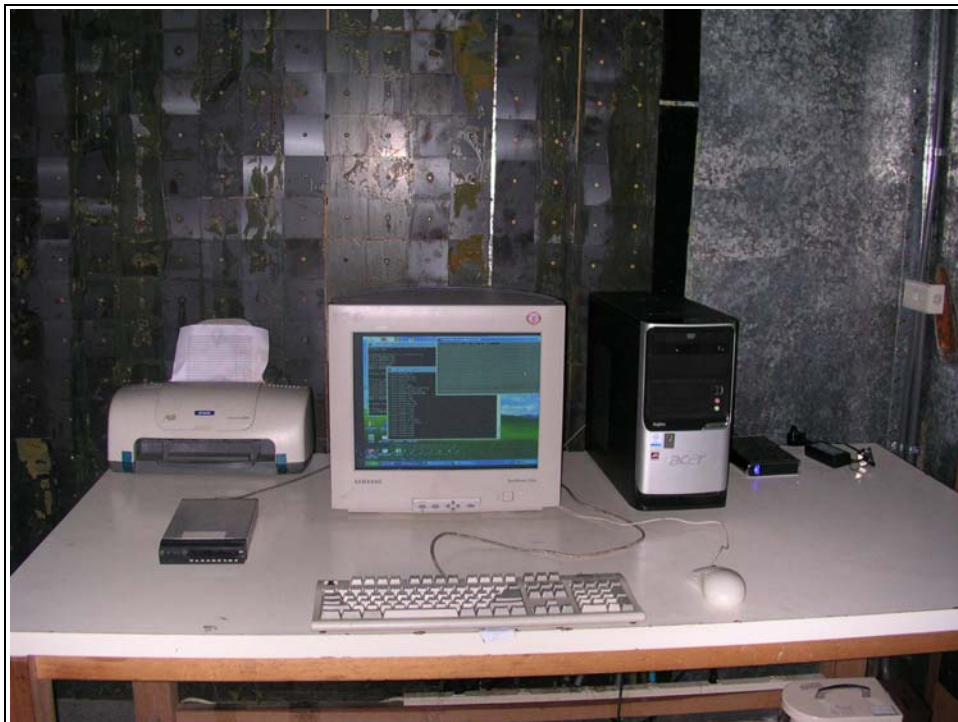



- Radiated immunity test

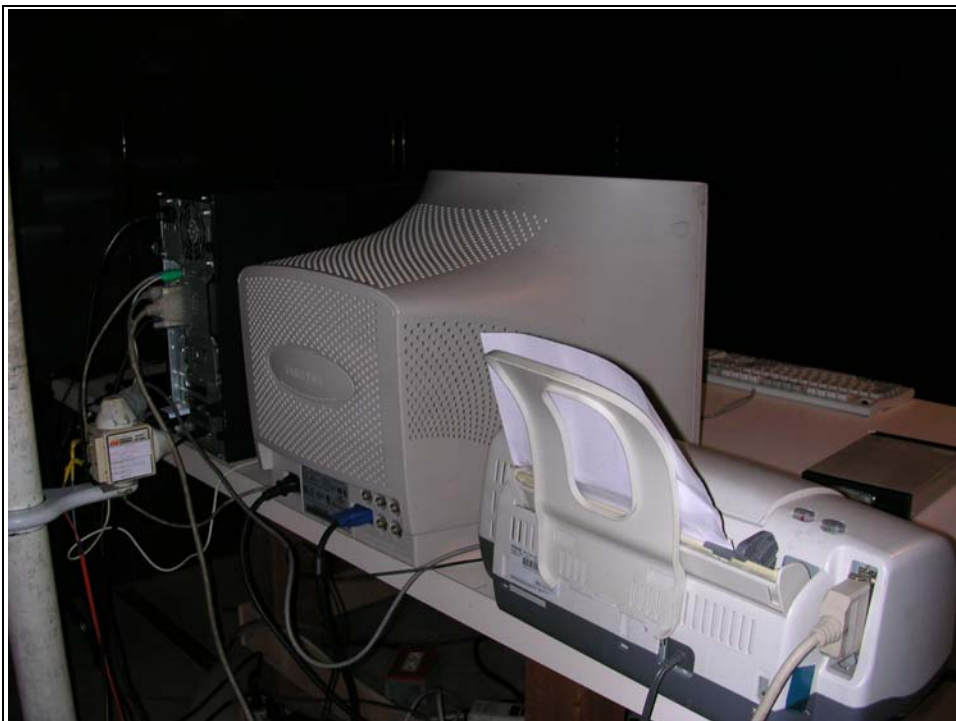



- Inducted RF fields (conducted susceptibility) test



- Power frequency magnetic-field test





Spectrum Research & Testing Lab., Inc.
No. 101-10, Ling 8,
Shan-Tong Li, Chung-Li
City, Taoyuan, Taiwan,
R.O.C.

TEST REPORT

Reference No.: A07012402
Report No.:EMCA06051501-01
Page:38 of 38
Date: Jan. 24, 2007.

11. TERMS OF ABBREVIATION

AV.	Average detection
AZ(°)	Turn table azimuth
Correct.	Correction
EL(m)	Antenna height (meter)
EUT	Equipment Under Test
Horiz.	Horizontal direction
LISN	Line Impedance Stabilization Network
NSA	Normalized Site Attenuation
Q.P.	Quasi-peak detection
SRT Lab	Spectrum Research & Testing Laboratory, Inc.
Vert.	Vertical direction