

Grounding Products and Systems



Facility Electrical Protection





Founded in 1903 as the Electric Railway Improvement Company, ERICO developed the CADWELD® exothermic welding process in 1938. CADWELD connections have found industry-wide acceptance as the ultimate electrical connection. During the 1970s, ERICO pioneered the development and standardization of the copperbonded steel grounding electrode. Since that time, ERICO's dominance as the world's leading supplier of grounding products has seen its expansion into many related industries.

Facility Electrical Protection Division

Lightning protection, grounding, equipotential bonding and surge protection are all interdependent disciplines, and the focus of our Facility Electrical Protection division. Reliable protection of structures, industrial and commercial operations and personnel, demands a systematic and comprehensive approach to minimizing threats caused by transients.

For instance, no air terminal can safely capture and arrest the lightning energy without a dependable route to ground.

Equally, even the most expensive Surge Protection Device (SPD) will not provide optimum protection if a low impedance electrical connection to the ground is not provided. The solution does not stop here - a low impedance ground system may create hazards to equipment and personnel alike if equipotential bonding practices are not followed. These interdependent disciplines are best applied when looking at a total facility rather than an individual piece of equipment or portion of the facility. Our team of qualified applications engineers is here to help you with such challenges.

Noting that there is no single technology that can eliminate the harmful effects of lightning or induced surge transients, ERICO Inc. has developed the Six Point Protection Plan. The concept behind this plan is to prompt the user to consider a holistic and coordinated approach to lightning protection, one embracing all aspects of potential damage. This ranges from the more obvious direct strike to the more subtle mechanisms of differential earth potential rises and voltage induction at service entry points. The six interdependent disciplines that form the protection plan are:

1. Capture the lightning strike to a known and preferred attachment point
2. Safely convey this energy to the ground
3. Dissipate energy into the grounding system
4. Bond all ground points together
5. Protect incoming AC power feeders
6. Protect low voltage data/telecommunications circuits

At ERICO, we offer more than just the best range of grounding and bonding products available. We offer engineering

experience and technical support that is second to none in the industry.

With this experience, ERICO is a world leading authority in the design and construction of permanent, low impedance, grounding systems.

ERICO's quality assurance program, ensures that detailed procedures required for every step of operation, including design, materials procurement, manufacturing, installation and testing, produce the best possible system for our clients.

Our research and development capabilities provide continuous design improvement with new and improved products that preempt the challenging

requirements of ever evolving industry applications. Engineering expertise is shared among the other ERICO operations worldwide, to provide the most comprehensive knowledge pool in the field.

Our commitment to providing cost-effective, permanent solutions for our customers is enhanced by on-site services, such as providing advice in choosing the right product for the job and comprehensive site surveys.



**FACILITY
ELECTRICAL
PROTECTION**



Table of Contents

Grounding Principles.....	2
Introduction.....	3
Grounding Principles.....	4 - 7
Ground System Components	
Ground Conductors.....	8
Grounding Clamps and Connectors.....	9 – 11
Ground Electrodes.....	12 – 17
Ground Electrodes and Accessories.....	18 – 30
Equipotential Bonding	
Introduction.....	31
Equipment Ground Bars.....	32 – 37
Perimeter Bus System.....	38
Equipment Ground Plates.....	39 – 40
Aircraft Receptacles.....	41
Transient Earth Clamp/Joint Protector.....	42
Signal Reference Grid (SRG).....	43 – 46
Signal Reference Grids & Grounding.....	47
Equipotential Mesh / Mats.....	48 – 52
Temporary Protective Grounding Jumpers.....	53
Bonding Devices.....	54 – 55
Temporary Protective Grounding Jumpers.....	56
Fence Post & Gate Grounding.....	57 – 59
Static Grounding and Bonding	
Static Grounding & Bonding Components.....	60
Static Grounding Conductors.....	61
Static Grounding Conductors & Clamps.....	62
Static Grounding Clamps.....	63 – 64
Static Grounding Components.....	65 – 66
Ground Testing	
Ground Test Equipment.....	67 – 68
Grounding Products and Systems	
Technical Section.....	69 – 80

Grounding Principles

Introduction

Grounding and bonding are an integral part of any modern electrical protection system design.

An effective, low-impedance ground system is a key element of this system. It is crucial in ensuring personnel safety, as well as providing reliable protection for vital equipment and to minimize interruptions of service and costly downtime.

With almost a century of experience in the design and manufacture of bonding and grounding products, ERICO®, a single source provider, offers what we believe is the best range of long lasting and cost-effective grounding products available.

The following pages of this catalog detail these products and their respective applications.



Definitions

Ground: A conducting connection, whether intentional or accidental, between an electrical circuit or equipment and the earth, or to some conducting body that serves in place of the earth.

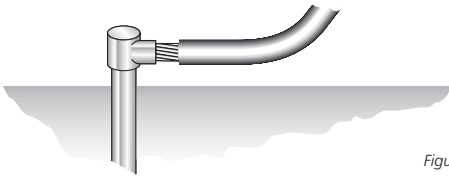

Figure 1.

Earth: The conductive mass of the earth, whose electric potential at any point is conventionally taken as equal to zero. (In some countries the term "ground" is used instead of "earth.")

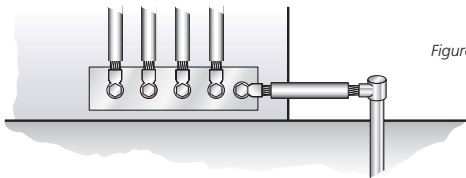

Figure 2.

Bonding: The permanent joining of metallic parts to form an electrically conductive path that will ensure electrical continuity and the capacity to conduct safely any current likely to be imposed.

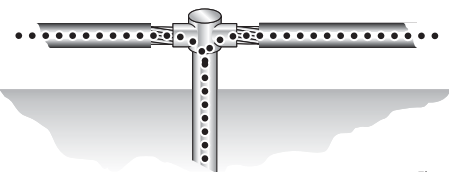

Figure 3.

The need to ground!

There are important reasons why a grounding system should be installed.

- 1 The most important reason is to protect people!
- 2 Protection of structures and equipment from unintentional contact with live conductors.
- 3 Ensure maximum safety from electrical system faults and lightning.

It is a fundamental fact that electricity **ALWAYS** flows to the point of lowest potential. The task is to ensure that electricity, including faults, lightning and electronic noise, flows to this point with maximum safety to people, while maintaining the reliability of equipment. Therefore we must ensure the safe, controlled flow of electricity with minimum voltage drop to earth in all cases.

Grounding Codes and Standards

Grounding needs vary according to function. The grounding requirements of a power system will vary from those of electrical equipment, lightning protection or for the proper function of electronic equipment.

Proper installation of appropriate grounding systems requires knowledge of the needs and layout of the facility. Soil characteristics, grounding conductor materials grounding connections and terminations, **are significant factors determining the design of a grounding system. Applicable standards and codes must be applied.**

While many codes and standards contain minimum grounding and bonding requirements, the design and installation of electrical grounding systems is one of the most important aspects of any electrical distribution system. However, codes and standards are often misunderstood and grounding systems subsequently installed improperly.



Introduction

The facility electrical ground system must:

- Efficiently dissipate lightning surge energy that may arrive via down-conductors of the lightning protection system;
- Efficiently dissipate electrical surges and faults to minimize the chances of injury from either "step potentials" or "touch potentials";
- Provide a stable reference for electrical and RF circuits at the facility to minimize noise during normal operation;
- Be properly bonded to provide an equipotential plane under fault conditions;
- Be electrically and mechanically robust to assure performance over the "life" of the facility (nominally 40 years from construction date).

Applicable Codes and Standards

European	American	Australian
IEC 10234-1	IEEE Std 80	AS3000--AS2307
IEC 61364-5	NFPA 70 (NEC)	AS 1768-
ENV 61024-1	UL 96A	
BS 1400	CSA C22.1-94	
BS 7430	NFPA 780	
BS6651	IEEE 837	
	IEEE 1100	
	IEEE 142	
	IEEE 81	

The primary functions of grounding can be defined as follows:

1. Personnel Safety

Avoid hazardous Step and Touch Potentials (shock) or even death by low impedance grounding and bonding between metallic equipment, chassis, piping, and other conductive objects so that currents, due to faults or lightning, do not result in hazardous voltage rise.

2. Equipment and Building Protection

A direct, low impedance path to ground and bonding between electrical services, protective devices, equipment and other conductive objects so that faults or lightning currents are quickly dissipated and do not result in hazardous voltages within the building. Proper grounding also facilitates the operation of over-current protective devices.

3. Electrical Noise Reduction

Proper grounding aids in electrical noise reduction and ensures:

1. Minimal impedance between the signal ground points throughout the building.
2. Minimal voltage potential between interconnected equipment.
3. Minimal effect of electrical and magnetic field coupling.

STEP POTENTIAL

Step Potential is the voltage difference between a person's feet caused by the dissipation gradient of a fault entering the earth.

TOUCH POTENTIAL

Touch Potential is similar to "Step Potential" except that the fault current passes through the person's arm and torso on the way to the ground.

Another function of the grounding system is to provide a reference for circuit conductors to stabilize their voltage to ground during normal operation. The earth itself is not essential to provide a reference function; another suitable inductive body may be used instead.

The function of a grounding electrode system and a ground terminal is to provide a system of conductors, which ensures electrical contact with the earth.

Figure 4. Typically, one meter from a fault entry point, voltage will be reduced by 50%. (e.g. A 1,000 Amp fault in a 5 Ohm grounding system will enter the earth at 5,000 volts. At a distance of less than one meter away, a fatal potential of 2,500 volts will exist).

STEP POTENTIAL

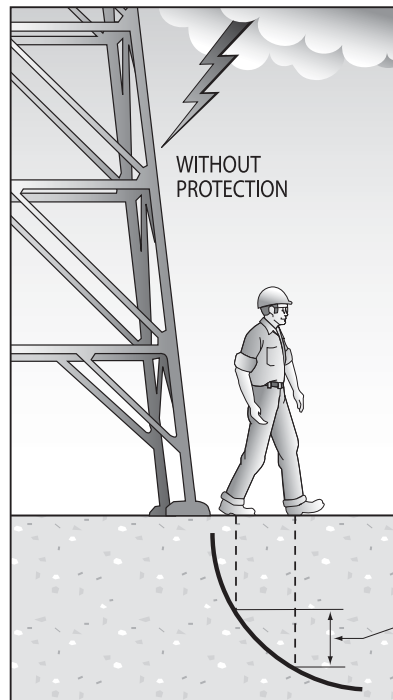

TOUCH POTENTIAL

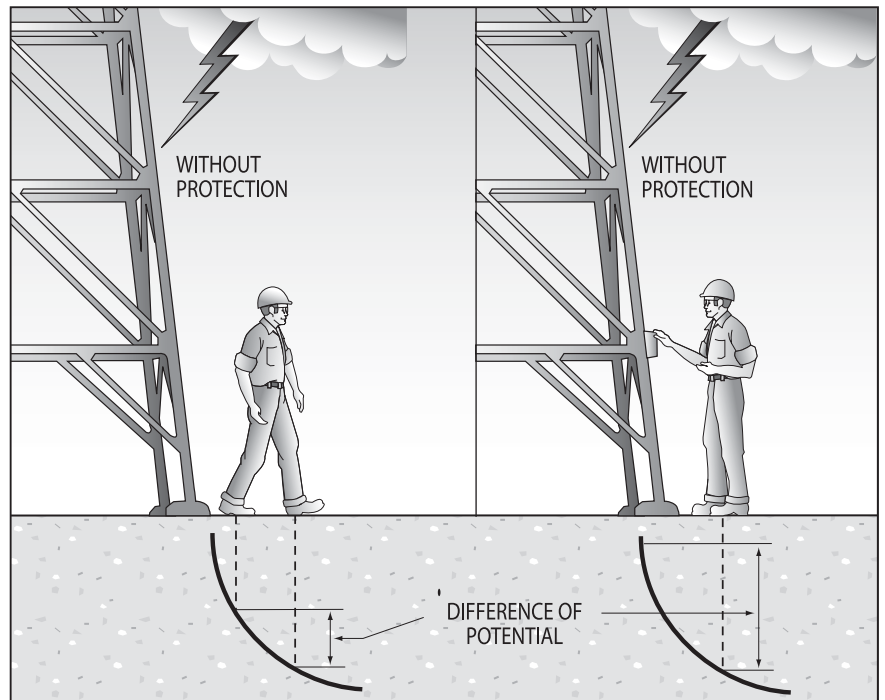

Grounding Principles

Ground Resistance

When current flows from a ground electrode into the surrounding soil, it is often described as flowing through a series of concentric shells of increasing diameter.

Each successive shell has a greater area for current flow and consequently, lower resistance. At some point distant from the earth conductor the current dissipation becomes so large and current density so small, that the resistance is negligible.

In theory, the ground resistance may be derived from the general formula:

$$R = \rho \frac{L}{A} \quad \text{Resistance} = \text{Resistivity} \times \frac{\text{Length}}{\text{Area}}$$

This formula illustrates why the shells of concentric earth decrease in resistance the farther they are from the ground rod:

$$R = \text{Resistivity of Soil} \times \frac{\text{Thickness of Shell}}{\text{Area}}$$

In the case of ground resistance, uniform earth (or soil) resistivity throughout the volume is assumed, although this is seldom the case in nature. The equations for systems of electrodes are very complex and often expressed only as

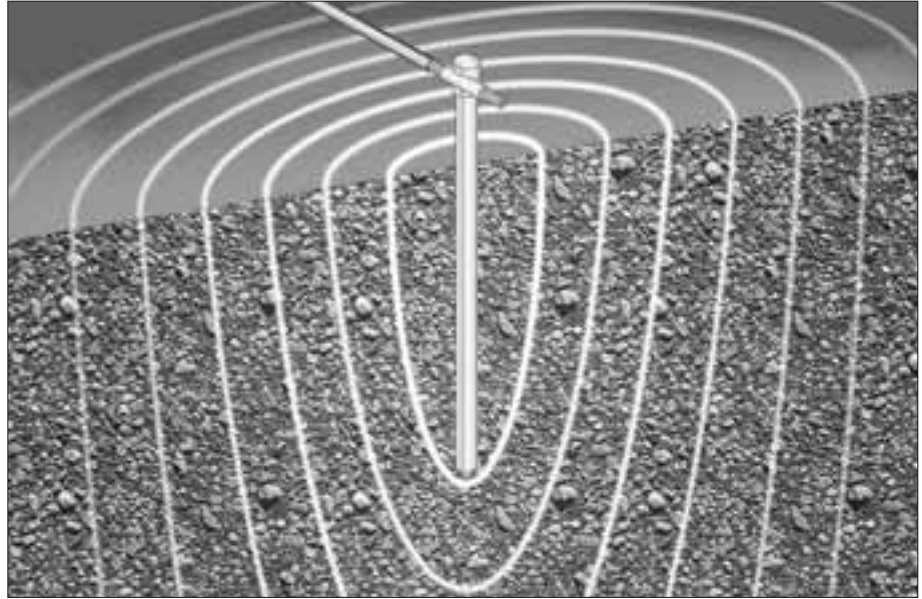

Figure 5. Sphere of Influence - electrical current flows from the ground rod into surrounding soil and progressively dissipates in waves of increasing diameter.

approximations. The most commonly used formula for single ground electrode systems, developed by Professor H. R. Dwight of the Massachusetts Institute of Technology, is the following:

$$R = \frac{\rho}{2\pi L} \{(\ln \frac{4L}{r}) - 1\}$$

R = resistance in ohms of the ground rod to the earth (or soil)

L = grounding electrode length

r = grounding electrode radius

ρ = average resistivity in ohms-cm.

Conditions Influencing Soil Resistivity

The resistance of the earth itself (soil resistivity) can significantly impact the overall impedance of the grounding system. Several factors, such as soil composition, moisture content, mineral content, contaminants, etc., determine the overall resistivity of the earth (refer Table 1).

SOIL TYPE	Resistivity ohm-cm		
	Average	Min.	Max.
Fills – ashes, cinders, brine wastes	2,370	590	7,000
Clay, shale, gumbo, loam	4,060	340	16,300
Clay, shale, gumbo, loam with varying proportions of sand and gravel	15,800	1,020	135,000
Gravel, sand, stones, with little clay or loam	94,000	59,000	458,000

U.S. Bureau of Standards Technical Report 108

Table 1. Soil Resistivity.

Soil Composition

Soil types vary in content and consistency. Black dirt or soils with high organic content, are usually good conductors because they retain higher moisture levels and have a higher electrolyte level. Sandy soils, which drain faster, have a much lower moisture content and electrolyte level. Therefore they have higher impedance. Solid rock and volcanic ash contain virtually no moisture or electrolytes and hence high levels of resistivity.

Soils have generally been deposited in layers or strata. These strata can have different values of soil resistivity. By measuring the resistivity of the soil at varying depths, it is possible to develop a profile, which can be used to identify the most appropriate ground electrode design.

Moisture Content

Moisture content has the largest influence on soil resistivity because it helps chemicals in the soil that surround ground conductors carry the electric current. In general, the higher the moisture content the lower the soil's resistivity.

Moisture retention can be influenced by local climate conditions and electrolytic mechanisms such as mineral content, soil ionization, consistent grain size, even distribution and packing density.

Systems designed for areas which typically have very dry soil and arid climates may need to use enhancement materials or other means to achieve lower soil resistivity.

Temperature

High temperatures and drought, or temperatures below freezing and deep frosts, can cause high resistivity in soils that have much lower values in the preceding months. When moisture turns to ice, resistivity increases sharply. Areas with regular rainfall and no ground frost are more likely to have low soil resistivity, in comparison to those regions that are arid or have permafrost.

In areas subject to freezing winters driving the ground rod below the frost line is necessary to maintain a low resistivity.



Grounding Principles

Soil Resistivity Testing

To properly design a grounding system, it is essential to test soil resistivity. Several methods can be used to measure earth resistivity: the four-point method, the variation in-depth method (three-point method) and the two-point method. The most accurate method and the one that ERICO® recommends is the four-point method.

The Four-Point Method

1. Four test stakes are positioned in a straight line an equal distance apart and are hammered into the ground to be surveyed to a depth of not more than 1/20 the distance between the adjacent stakes.
2. An earth resistance tester is connected to these four stakes as shown in Figure 6.
3. The DC test option on the tester is then selected and performed, and the resistance figure "R" recorded.
4. The soil resistivity level "r" (in ohms/cm) is then calculated using the formula: $r=2paR$ where:

R = the resistance figure, in ohms
a = the separation of the test stakes, in meters.

$$\rho = \frac{4\pi AR}{1 + \frac{2A}{\sqrt{(A^2 + 4B^2)}} - \frac{2A}{\sqrt{(A^2 + 4B^2)}}$$

Where:

A = distance between the electrodes in centimeters

B = electrode depth in centimeters

If $A > 20 B$, the formula becomes:

$$\rho = 2\pi AR \text{ (with A in cm)}$$

$$\rho = 191.5 AR \text{ (with A in feet)}$$

ρ = Soil resistivity (ohm-cm)

This value is average resistivity of the ground at a depth equivalent to the distance "A" between two electrodes.

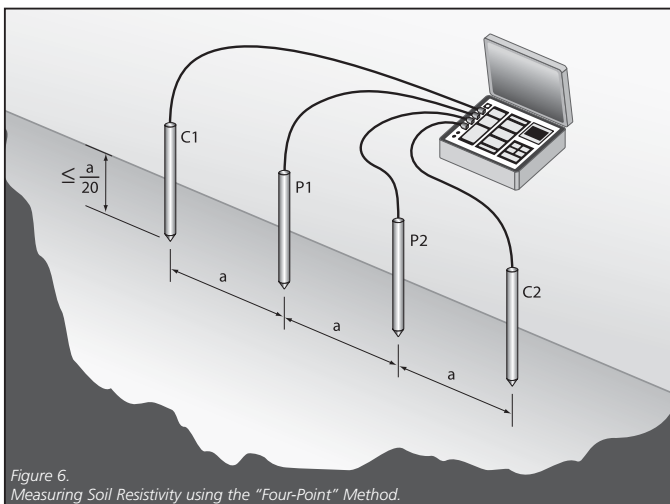

Figure 6.
Measuring Soil Resistivity using the "Four-Point" Method.

A Line Traverse Soil Resistivity Survey

Soil resistivity levels can vary significantly both with depth, and from one point to another on a site, and as such, a single soil resistivity measurement is usually not sufficient. To obtain a better picture of soil resistivity variations, it is advisable to conduct a detailed survey.

The Line Traverse technique is a commonly used method for performing soil resistivity surveys. In this method imaginary parallel lines are drawn across the area to be surveyed. Taking a number of measurements along each 'line' using different stake separations provide an indication of how the soil resistivity varies with depth, while measurements taken along different lines provide an indication of how the resistivity changes across the site.

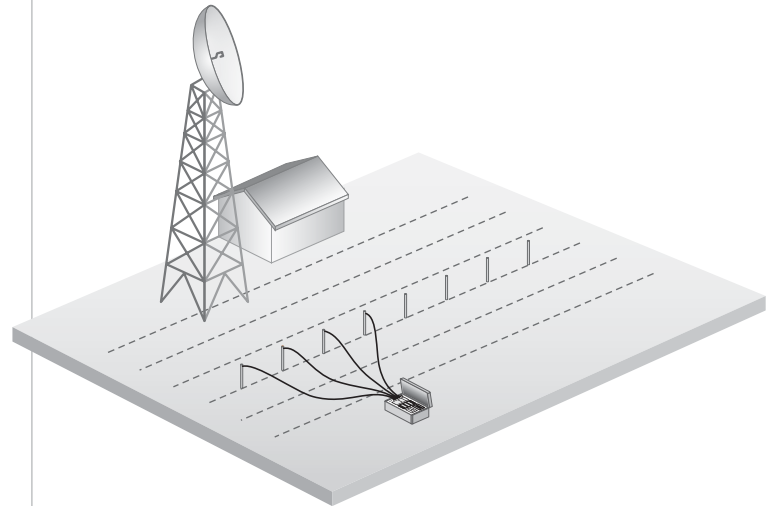

Figure 7. Performing a Line Traverse survey. A commonly used method for soil resistivity survey work.

Grounding Principles

Types of Grounding Systems

The basic philosophy of any ground electrode installation should be an attempt to maximize the surface area contact with the surrounding soil. Not only does this help to lower the resistance of the grounding system, but it also greatly improves the surge impedance of the

grounding system due to the large capacitive coupling which is achieved.

The actual layout of the grounding system, and the number, length and depth of ground rods will vary with the usages, type of soil and space availability. Some common designs include:

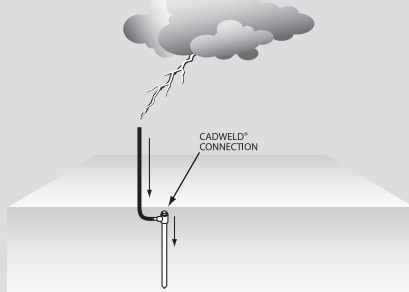

Single Ground Rod

One single ground electrode may be sufficient for an electrical installation in a built up area where the local supply authority utilizes a multiple or common multiple earth neutral (MEN or CMEN) system. However, it may not provide an adequately low impedance for lightning current injection.

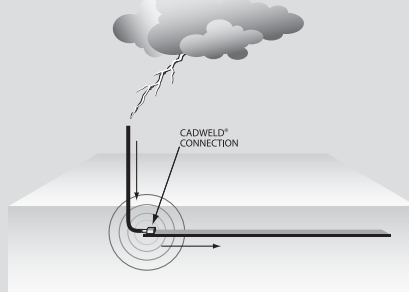

Single Strip End Connected

This is a common option for installations where, because of rock, driving an electrode is impractical. It is not recommended for lightning protection systems as there is only one path. Very high ground voltages will be experienced at the injection point.

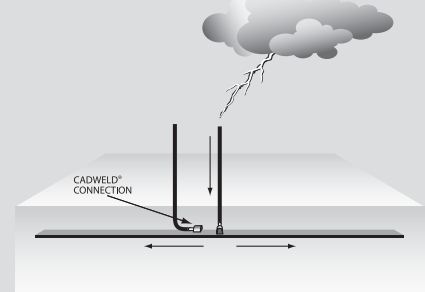

Single Strip Center Connected

Since the connection to the strip is at the center, any fault/injection current travels in two directions. This layout has lower impedance, but it is generally not adequate for lightning protection systems.

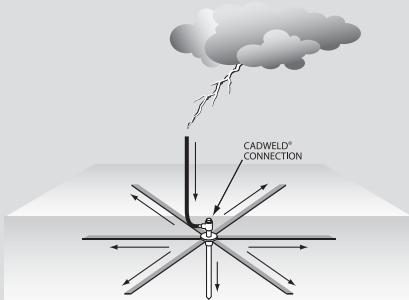

Radial Grounding, Single Radials

A design that is well suited to lightning protection in areas of medium resistivity. The radials can run to 100 feet in length.

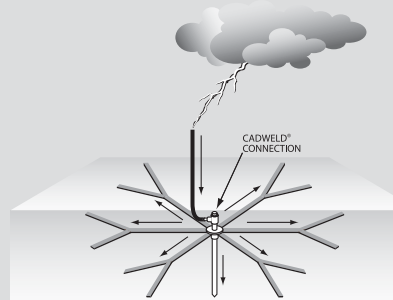

Radial Grounding, Multiple Radials

Crows foot design. Well suited to lightning as it allows energy to diverge as each conductor takes a share of the current, offering a lower impedance. Voltage gradients leading away from the injection point will be lower, reducing danger from step potentials.

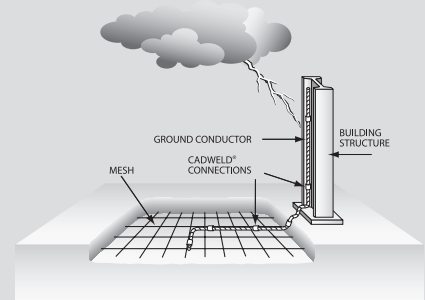

Equipotential Mesh Electrodes

Minimize the risk of step and touch potential hazard by positioning a mat and bonding it to the structure or operating handle at locations where personnel may be required to operate switchgear or stand in the course of their duties. Low ground impedance.

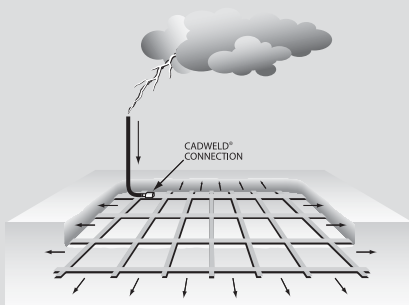

Grid Electrodes

Grounding for installations where there is concentration of electrical equipment, such as electrical substations, are often designed to meet a specific value of resistance (typically 1 ohm). Under fault conditions, a grid can dissipate currents over a large area.

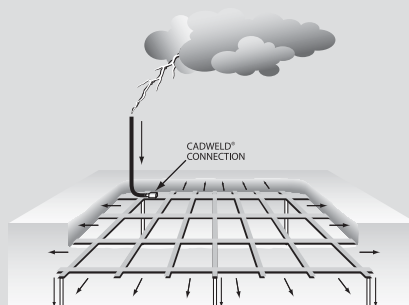

Grid with Ground Rods

It may be advantageous to add ground rods to the grid. In doing so, it may be possible to access a low resistivity soil layer. Care must be taken to ensure each ground rod is spaced at least twice the installation depth.

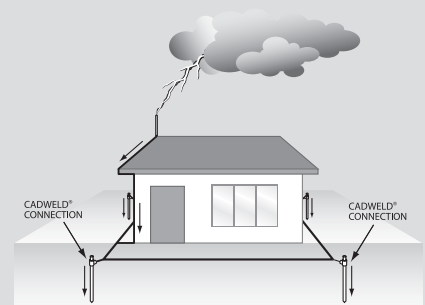

Ring Electrode

Installations, including communications huts, pad mount transformers and fences surrounding high voltage installations, are generally surrounded by a ground ring. This practice also reduces the hazard of step and touch potential.

Figure 8.



Grounding Principles

Ground / Earthing System Design

Grounding systems are important. It is not expensive to build an appropriate ground system during initial construction of a facility, but it can be very expensive to add to it, enhance it, or replace it after the facility is complete. Care should be taken to design a system that is appropriate both for clearing ground faults and dissipating lightning energy. The system must have a long performance life, meet applicable codes / standards for safety, and have sufficient bonding points to make it easy to add new equipment / facility grounding to it easily.

Design considerations include:

- Purpose of facility
- Design life of facility
- Soil resistivity at 3 depths
- Corrosive nature of soil
- Shape and available area of facility site
- Existing structures and their grounding systems
- Seasonal variations in moisture and temperature for facility site
- Public access & personnel use
- Adjacent facilities and electrical systems
- Future uses, additions, equipment for facility

For proper operation of overcurrent devices, it is important to have a low DC ohmic resistance to remote earth. In many instances, this is best achieved by installing a deep ground electrode on site. It should be driven deep enough to reach the permanent water table.

For dissipation of direct or indirect lightning currents, it is better to have many horizontal ground conductors in the soil, preferably in a radial array. This provides a low impedance path of dissipation to the high frequency component of the lightning energy.

For safety of personnel, particularly where people congregate or where equipment operators will be located, it is important to have a grid system or other equipotential plane to reduce "step potential" and have equipment and metal structures bonded to the ground system to reduce "touch potential".

A proper facility grounding system incorporates these necessities in the most cost-effective manner that will last for the design life of the facility.

ERICO® is a manufacturer and marketer of grounding, bonding, lightning protection and surge protection products and systems. ERICO has many knowledgeable and experienced engineers on staff with the training and the tools (including some of the latest design software) to design appropriate grounding systems. These engineers can assist facility owners, engineers and contractors in designing the most appropriate system for the facility in question.

Grounding Chain

- Grounding Electrode Conductor
- Grounding Connections
- Grounding Electrode
- Electrode to Soil Resistance
- Soil

The Grounding Chain

The performance of the grounding system is determined by the quality of the following five components all of which are of equal importance.

1. The Grounding Electrode Conductor. Typically made from copper or copper-clad steel, the grounding electrode conductor must be large enough to withstand the maximum available fault current over the maximum clearing time.
2. The Grounding Connections. Often overlooked, the grounding connections are used to tie the elements of the electrode system together. Exothermically welded connections provide a molecular bond that will never loosen or corrode. Mechanical connectors, such as crimp, bolted, and wedge type, rely on physical point-to-point surface contact to maintain the integrity of the electrical connection. IEEE Standard 837 provides detailed information on the application and testing of permanent grounding connections. ERICO can provide an independent, third-party test report evaluating the performance of these connectors in accordance with the testing procedures set forth in IEEE 837 Standard for Qualifying Permanent Substation Grounding Connections.
3. The Grounding Electrode. The grounding electrode provides the physical connection to the earth and is the instrument used to dissipate current into it. There are two main types of electrodes. "Natural" electrodes are intrinsic to the facility and include metal underground water pipe, the metal frame of the building (if effectively grounded), and reinforcing bar in concrete foundations. "Made" electrodes are installed specifically to improve the performance of the ground system and include wire meshes, metallic plates, buried copper conductor and rods or pipes driven into the ground. The ground rod is the most widely used electrode.
4. Electrode to Soil Resistance. Amount of rod surface and rod replacement are the controlling factors. Doubling diameter reduces resistance by only 10% and is not cost effective. Doubling rod length, however, theoretically reduces resistance by 40%. The most common solution is proper placement of multiple rods that are driven to the required depths.
5. The Soil. The soil resistivity, measured in ohm-centimeters or ohm-meters, plays a significant role in determining the overall performance of the grounding system and must be known before a proper grounding system can be engineered. Measuring soil resistivity allows the design engineer to locate an area with the most conductive soil and to determine the depth of the conductive soil so that electrodes can be placed accordingly.

The grounding system will carry little or no current for long periods of time until a fault occurs or a lightning strike or other transient requires dissipation. At that point, the grounding system components will be expected to perform like new while conducting large amounts of current. Most of the grounding system is concealed below grade, making inspection of the grounding components difficult or impossible. The underground environment is a harsh one. The initial selection of the components used in the grounding system is of critical importance to its long-term effectiveness.

Ground System Components

Ground Conductors

Conductors

There are two basic criteria for grounding conductor selection:

1. The physical characteristics of the conductor must be of a robust nature, sufficient for the environment.
2. The cross sectional area of the conductor must be of sufficient size, so that it shall successfully conduct the maximum fault (surge) current for a period, which allows the operation of protection equipment (or the dissipation of this energy).

Physical Characteristics

The most common ground conductor is a soft drawn, stranded copper conductor. Flat copper strip / tape is also popular because it offers a large surface area. When site conditions are corrosive towards copper (eg. sulphurous soil), a tinned copper conductor is often the first choice.

In some circumstances, the maximum fault current for the installation is small. While a conductor of correspondingly small size could be used, a minimum cross section, often set by the governing authority or applicable Standards body (to minimize potential damage likely to occur from any future excavation on the site), is applied.

Maximum Fault Current

Where higher fault conditions exist, the conductor size is determined by considering the circumstances required to avoid fusing (melting) the conductor. The accepted industry Standard is IEEE 80, Guide for Safety in Substation Grounding.

ERITECH® Flat Strip Ground Conductor

- Pure electrolytic copper
- Low impedance
- Lower impedance than equivalent sized round conductor

Part No.	Description	Dimensions		
		H (in.)	W (in.)	L (ft.)
A811A26F20	Copper Strip, roll	.0159	2	20
A811A26F50	Copper Strip, roll	.0159	2	50
A811A26F500	Copper Strip, roll	.0159	2	500
A811C20F100	Copper Strip, roll	.032	3	100
A811K26F100	Copper Strip, roll	.0159	6	100
A811K20F100	Copper Strip, roll	.032	6	100

Also available tin plated

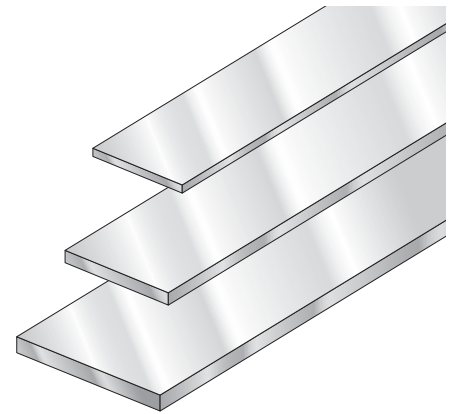

ERITECH Ground Conductor

- Pure electrolytic copper

Part No. (100 Ft. Reel)	Part Number (250 Ft. Reel)	Wire Size	Type	Description
A809A07F100	A809A07F250	#2	Solid	Bare
A809A06F100	A809A06F250	#4	Solid	Bare
A809A04F100	A809A04F250	#6	Solid	Bare
A809A07TF100	A809A07TF250	#2	Solid	Bare Tinned
A809A02F100	A809A02F250	#2	7 Strand	Bare
A809A01F100	A809A01F250	#4	7 Strand	Bare
A809A024F100	A809A024F250	#6	7 Strand	Bare
A819A02F100	A819A02F250	#2	7 Strand	THW insulation
A819A03F100	A819A03F250	#4	7 Strand	THW insulation
A819A04F100	A819A04F250	#6	7 Strand	THW insulation



Ground System Components

Grounding Clamps and Connectors

ERITECH® Ground Clamps

- For use with copperbonded ground rods.
- Suitable for direct burial.

Bronze Standard Duty

Part No.	Conductor Range	Rod Size
CP38	10 Sol.- 4 Str.	3/8
CP12	8 Sol.- 2 Str.	1/2
CP58	8 Sol.- 2 Str.	5/8
CP34	8 Sol.- 2 Str.	3/4

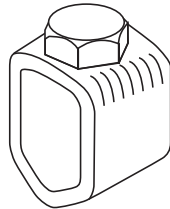

Bronze Heavy Duty

Part No.	Conductor Range	Rod Size
HDC12*	10 Sol.- 2 Str.	1/2
HDC58R*	8 Sol.- 1/0 Str.	5/8
HDC58*	8 Sol.- 1/0 Str.	5/8
HDC34*	8 Sol.- 1/0 Str.	3/4
HDC34SP	8 Sol.- 3/0 Str.	3/4
HDC1	1 Sol.- 4/0 Str.	1

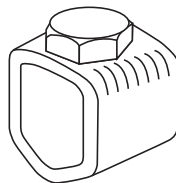

*UL Listed

Galvanized Steel Clamps

Part No.	Rod Size
S58	1/2" rod #8 - 3/0 wire 5/8" rod #14 - 1/0 wire
S68	5/8" rod #14 -16 wire 3/4" rod - 4/0 wire

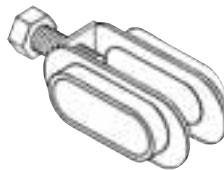

ERITECH Split Bolts - Silicon Bronze

Part No.	Wire Range
ESB8	10 sol - 8 str.
ESB6	8 sol - 6 sol.
ESB4	8 sol - 4 sol.
ESB3	6 sol - 3 str.
ESB2	6 sol - 2 str.
ESB1/0	4 sol - 1/0 str.
ESB2/0	2 sol - 2/0 str.
ESB4/0	2 sol - 4/0 str.
ESB250	#1 str - 250 KCM
ESB350	250 KCM - 350 KCM
ESB500	400 KCM - 500 KCM

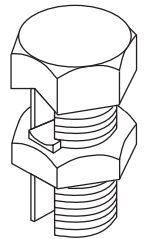

ERITECH Split Bolts - Tin Plated Silicon Bronze

Part No.	Wire Range
ESBP8	12 sol - 8 str.
ESBP6	10 sol - 6 sol.
ESBP4	10 sol - 4 sol.
ESBP2	6 sol - 1 sol.
ESBP1/0	2 sol - 1/0 str.
ESBP2/0	2 sol - 2/0 str.
ESBP4/0	2 sol - 4/0 str.
ESBP350	250 KCM - 350 KCM
ESBP500	400 KCM - 500 KCM

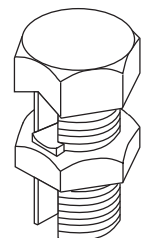

Ground System Components

Grounding Clamps and Connectors

ERITECH® Bronze Water Pipe Clamps

- High-strength silicone bronze clamps can be utilized for connecting copper conductors to metallic water pipe or ground rods.

Part No.	Water Pipe Size	Conductor Range	
		Min.	Max.
CWP1J**	1/2-1	10 Sol.	2 Str.
CWP1JJ	1/2-1	10 Sol.	4 Str.
CWP2J**	1-1/4-2	10 Sol.	2 Str.
CWP4J**	2-1/2-4	10 Sol.	4 Str.
CWP6J	4-1/4-6	10 Sol.	4 Str.
CWP1JU*	1/2-1	10 Sol.	2 Str.
CWP2JU*	1-1/4-2	10 Sol.	2 Str.

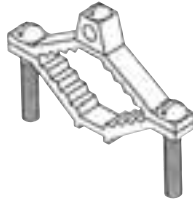

*With copper screw for use in direct burial applications.
**UL Listed

ERITECH Bronze Water Pipe Clamps

- For use in grounding armored cable to metallic pipe

Part No.	Water Pipe Size	Conductor Range	
		Min.	Max.
CWP1JA	1/2-1	10 Sol.	6 Sol.
CWP2JA	1-1/4 - 2	10 Sol.	6 Sol.
CWP4JA	2-1/2 - 4	10 Sol.	6 Sol.

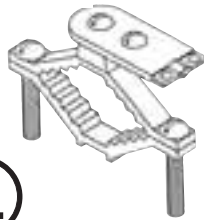

ERITECH Zinc Water Pipe Clamp

Part No.	Water Pipe Size	Conductor Range	
		Min.	Max.
ZWP1J	1/2-1	10 Sol.	6 Sol.

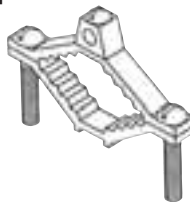

ERITECH Dual Rated Aluminum Water Pipe Clamps

- For use with copper or aluminum conductors.

Part No.	Conductor Range		Pipe Range
	Min.	Max.	
EGC1	14 Sol.	10 Sol.	1/2 - 1

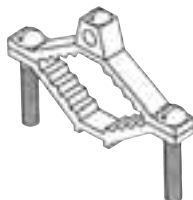

ERITECH Bronze Water Pipe Clamps

- For use in grounding rigid conduit systems to metallic water pipe.

Part No.	Water Pipe Size	Conduit Size	Conductor Range	
			Min.	Max.
CWP1JH12	1/2 - 1	1/2	10 Sol.	6 Sol.
CWP2JH12	1-1/4 - 2	1/2	10 Sol.	6 Sol.
CWP4JH12	2-1/2 - 4	1/2	10 Sol.	6 Sol.
CWP1JH34	1/2-1	3/4	10 Sol.	2/0 Str.
CWP2JH34	1-1/4 - 2	3/4	10 Sol.	2/0 Str.
CWP4JH34	2-1/2 - 4	3/4	10 Sol.	2/0 Str.
CWP1JH44	1/2 - 1	1	10 Sol.	3/0 Str.
CWP2JH44	1-1/4 - 2	1	10 Sol.	3/0 Str.
CWP4JH44	2-1/2 - 4	1	10 Sol.	3/0 Str.

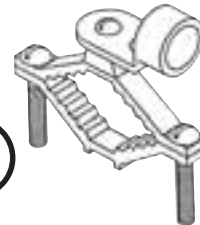

ERITECH Bronze Water Pipe Clamps

With Copper Strap - Heavy-Duty Hub

Part No.	Water Pipe Size	Conduit Size	Conductor Range	
			Min.	Max.
CWP12SH	1/2 - 1	1/2	10 Sol.	6 Sol.
CWP34SH	1/2 - 1	3/4	10 Sol.	2/0 Str.
CWP44SH	1/2 - 1	1	10 Sol.	3/0 Str.

With Copper Strap - Standard-Duty Hub

Part No.	Water Pipe Size	Conduit Size	Conductor Range	
			Min.	Max.
CWP12SH-E	1/2 - 1	1/2	10 Sol.	6 Sol.
CWP34SH-E	1/2 - 1	3/4	10 Sol.	2/0 Str.
CWP44SH-E	1/2 - 1	1	10 Sol.	3/0 Str.

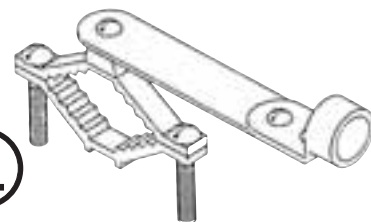

Ground System Components

Grounding Clamps and Connectors

ERITECH® Pipe Clamp

- 2" wide tinned copper strap draws tightly around pipe (all hardware is included)
- Conductor stub is easily spliced to ground conductor
- Adjusts to fit pipes from 3" NPS to 12" NPS
- CADWELD® connection of conductor to strap eliminates a mechanical interface

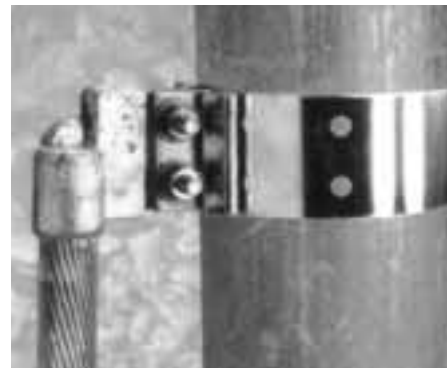
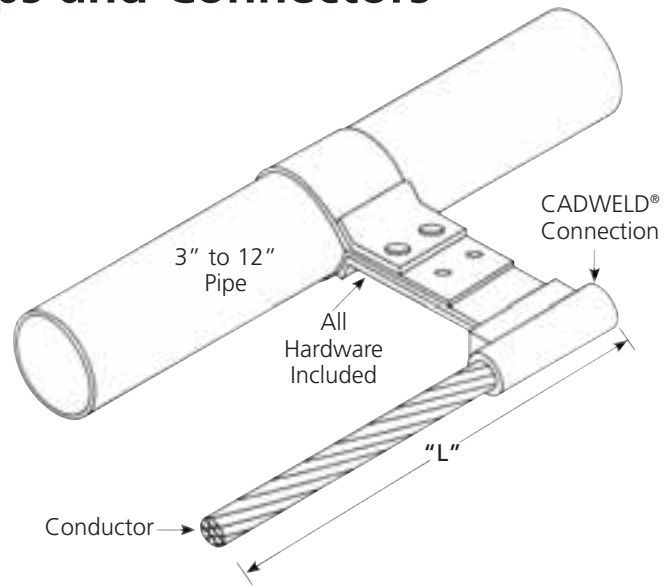

Figure 9. ERITECH Pipe clamp fitted to metal pipe with conductor stub CADWELD exothermically welded to copper conductor.

Ordering Information:

Part No. B852A12C

Conductor Code

Conductor Length, inches "L"

Example: 4/0 Bare, 12 Inches Long;
Part No. B852A12C2Q12

CONDUCTOR SIZE	CONDUCTOR CODE
1/0	2C
2/0	2G
4/0	2Q
250	2V
500	3Q
750	4L

ERITECH Transformer Tank Ground Connectors

- Cast of high conductivity bronze and 1/2"-13 stud. Fits all standard EEI-NEMA distribution transformers.
- Eyebolt rotates to accommodate cable in either vertical or horizontal direction and no special tools are required - use regular lineman's wrench.
- RUS Listed.

ERITECH Aluminum Mechanical Connectors

Part No.	Wire Range
4AT	14 sol - 4 str.
2AT	14 sol - 2 str.
10AT3	14 sol - 1/0 sol.
20AT	14 sol - 2/0 str.
300AT	6 sol - 300 KCM
350AT	6 sol - 350 KCM
10AT32	14 sol - 1/0 str.
20AT2	14 sol - 2/0 str.
300AT2	6 sol - 300 KCM
350AT2	6 sol - 350 KCM

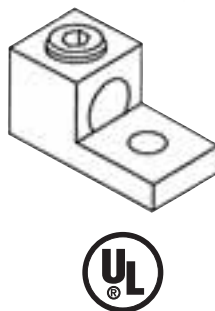

ERITECH Copper Mechanical Connectors

Part No.	Wire Range
ECM25	14 str - 10 str.
ECM35	14 str - 6 str.
ECM70	8 str - 2 str.
ECM125	8 str - 1/0 str.
ECM175	4 str - 3/0 str.

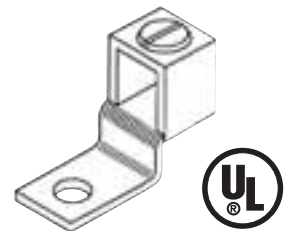

Part No.	Conductor Range		Stud Thread Size
	Max.	Min.	
TGC2/0	2/0 Str.	8 Sol.	1/2" - 13

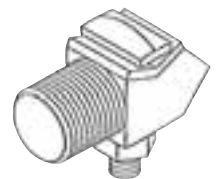

Ground System Components

Ground Electrodes

Ground Electrodes

The ground electrode is a critical component of the grounding system. Many different types of electrodes are available, some "natural" and some "made". The natural types include metal underground water pipe, the metal frame of a building (if effectively grounded), a copper wire or reinforcing bar in a concrete foundation or underground structures or systems. Consideration should be given to bonding of natural earths to ensure electrical continuity with a facilities' other "earths".

"Made" electrodes are specifically installed to improve the system grounding or earthing. These earth electrodes must ideally penetrate into the moisture level below the ground level to reduce resistance. They must also consist of metal conductors (or a combination of metal conductor types), which do not corrode excessively for the period of time they are expected to serve. Made electrodes include rods or pipes driven into the earth, metallic plates buried in the earth or a copper wire ring encircling the structure. Underground gas piping or aluminium electrodes are NOT permitted for use as ground electrodes.

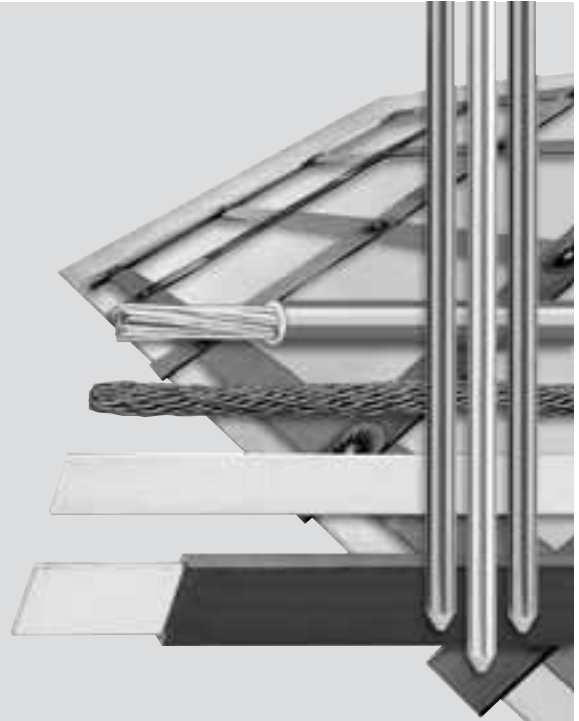

Ground Rods

Which ground rod should be used?

Ground rods are often selected on the basis of their resistance to corrosion. The other major factor is cost. All too often, the cost of a product is seen as the initial, up front price, but the real cost is determined by the serviceable life of the ground rod.

Galvanized steel rods are one of the cheapest electrodes available. However, they are not the most cost effective since they have a relatively short service life. Solid copper and stainless steel rods have a long service life. However, they are considerably more expensive than galvanized steel rods. In addition to this, solid copper rods are not suited to deep driving or even driving short lengths into hard ground, without bending.

As a compromise, steel cored ground rods, swaged in a copper or stainless steel sheath were developed. These ground rods are much less expensive than their solid counterparts. They are capable of being deep driven. However, the sheath of this rod type has been known to slip or tear, particularly the copper version. Once this sheath has been damaged, the integrity of the entire electrode is at risk.

Ask for the ERICO® White Paper on Ground Rods – Copperbonded vs. Galvanized.

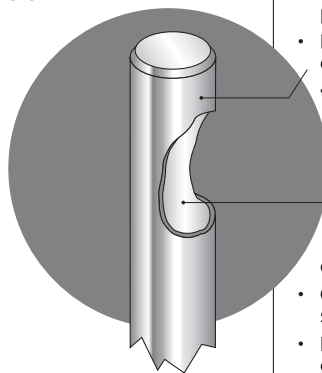

Figure 10.
Copperbonded ground rod
versus Galvanized ground rod.

COPPERBONDED GROUND ROD	GALVANIZED GROUND ROD
<ul style="list-style-type: none">• Cost effective - long service life <p>Copperbonded coating:</p> <ul style="list-style-type: none">• Permanent molecular bond• Low resistance performance• High fault current capacity (IEEE Std 80)• Will not slip or tear when driven• Will not crack if rod is bent <p>Carbon Steel core and tip:</p> <ul style="list-style-type: none">• Greater tensile strength• Deep driving capability	<ul style="list-style-type: none">• Lower purchase price - not as cost effective as Copperbonded <p>Galvanized coating:</p> <ul style="list-style-type: none">• Relatively short service life• May crack if rod is bent <p>Steel core and tip:</p> <ul style="list-style-type: none">• High tensile strength• Deep driving capability



Ground System Components

Ground Electrodes

The copperbonded ground rod has an electrolytic coating of copper deposited over a layer of nickel. This process ensures a long lasting, molecular bond between the copper layer and the steel core. ERICO® recommends copperbonded ground rods because the copper coating will not slip or tear when driven nor will it crack if the rod is bent. The tough, carbon steel core has good characteristics for deep driving. Copperbonded ground rods have a high resistance to corrosion and provide a low resistance path to ground.



Figure 11.
Photo shows two ground rods subjected to the same pressure load test. The ERITECH® copperbonded ground rod, shown on the left, will bend without tears, cracks or folds, to the outer sheath. The inferior copperclad rod shown on right, has developed cracks and creases to the outer sheath, which will significantly reduce its servicable life and put the integrity of the entire electrode at risk.

The Stainless Steel Option

It is important to note that certain soils and land fill areas may not be compatible with copper. In these situations, stainless steel is a better proposition. Stainless steel may also be an alternative, where structures or components, such as steel towers, poles or lead sheathed cables are in close proximity to an array of ground electrodes. In these circumstances, consideration must be given to the consequence of galvanic corrosion. The high cost of stainless steel rods prohibits their widespread use.

GROUND ROD LIFE EXPECTANCY

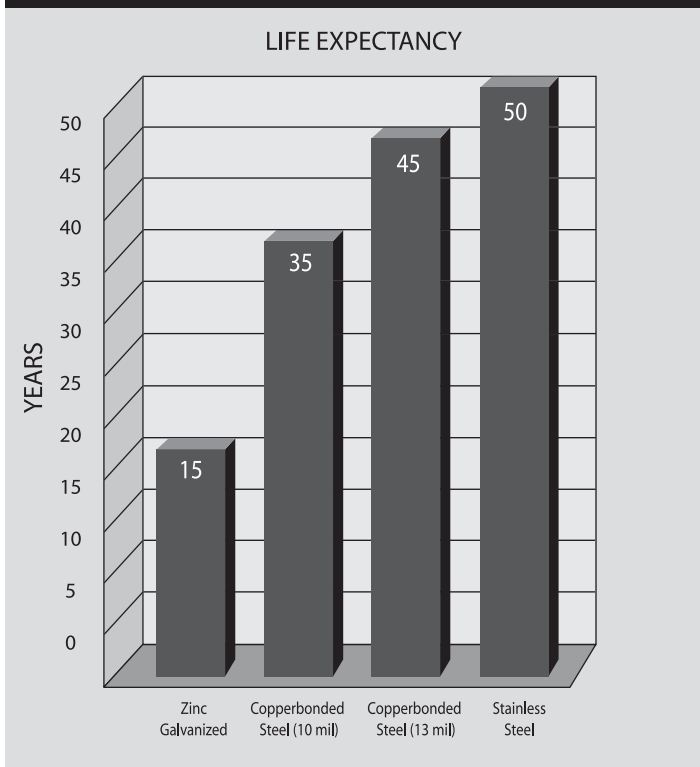

Figure 12.

GROUND ROD ANNUAL COST

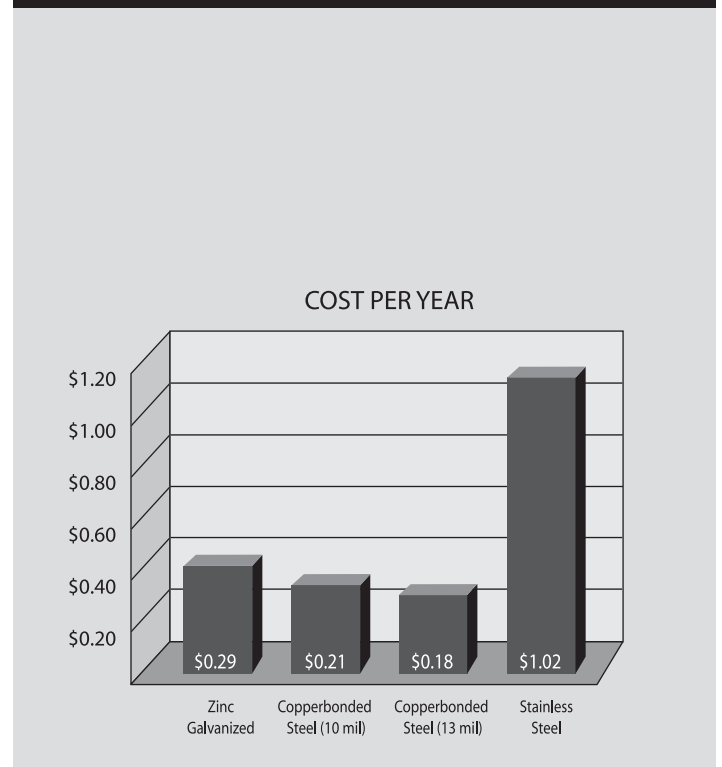

Figure 13.

Ground System Components

Ground Electrodes

Ground Rod Accessories and Application

ERICO® is the world's largest manufacturer of UL listed ground rods and accessories and offers a complete range of rods, driving heads, rod coupling methods and connections for reliable grounding in nearly any application.

Driving Sleeves

The driving head fits over the ground rod to protect the rod end from "mushrooming" as the ground rod is driven into earth.

Coupling

Couplings enable ground rods to be driven deep quickly and easily without the risk of rod separation. They are generally tapered so when the rod is driven into the coupling, the two parts compress to form a conductive connection.

Ground Rod

Ground Rod Diameter & Length

Ground rod diameter must also be considered. Although larger diameter rods are more rigid and less prone to whip or bending, they may have a greater drag than smaller diameter rods when being driven. It must also be noted that increasing the ground rod diameter has little impact on grounding system resistance. Standards nominate a minimum diameter or periphery and thickness if not cylindrical.

In general, lightning protection standards recommend copper bonded electrodes of specified diameter. Standard UL 467 requires a minimum rod length of 8' with a minimum diameter of 0.50" and 10 mils of copper.

Other Standards may nominate a specific resistance for the installation. If space is limited, the contractor may be required to install electrodes to a depth that achieves the required value.

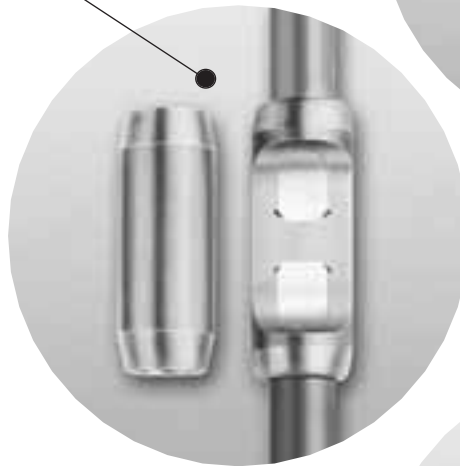
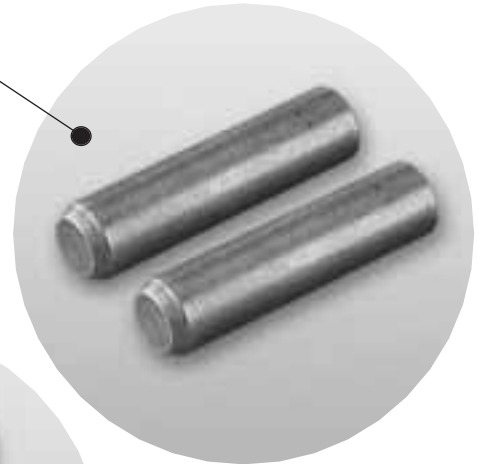

Ground System Components

Ground Electrodes

Ground Rod Installation

There are two main methods of installing ground rods.

- It is common for the ground rod to be driven into the earth using a hand held ground rod driver or mechanically operated driver.
- Where driving the rod is not possible due to ground conditions, a hole may be drilled to take the ground rod.

ERITECH® Ground Rod Driver

The ERITECH Ground Rod Driver from ERICO® is a safe, simple and effective way to install longer ground rods. This one tool enables driving of rods to ground level, without heavy sledge-hammers or ladders. This saves time and money and dramatically reduces risk of employee injury.

Features

- Suitable for use on all types of cylindrical ground rods: copper-bonded, galvanized, stainless steel.
- 5/8" and 3/4" inserts are interchangeable with standard driver body to enable easy driving of standard rods.
- Integral insert prevents driver from slipping off the rod near ground level.
- The driver will not deform the end of the rod – making the connection of the ground conductor quick and easy.
- Convenient retaining collar holds the insert in tool when not in use.
- Self-contained and easy to store.
- Heavy-duty steel construction provides robustness and excellent driving force.
- Soft rubber ergonomic grip provides user comfort.



Figure 14. The ERITECH Ground Rod Driver from ERICO, provides a safe, simple and affordable way to install ground rods.



Ground System Components

Ground Electrodes

Installation of Ground Rods

Using the ERITECH® Ground Rod Driver



Figure 15.

Step One

Remove the insert and slide driver body over ground rod.



Figure 16.

Step Two

Position rod in vertical position and drive rod by sliding driver body in an up-and-down motion over the ground rod.



Figure 17.

Step Three

When the end of the rod reaches approximately 900mm (30") above ground, slide the body off the rod and place insert on ground rod. Slide the driver body over the insert and drive rod to installed depth.

ERITECH Ground Rod Drivers

- Heavy-duty steel construction provides maximum driving forces, while the soft rubber ergonomic grip provides user comfort.
- 5/8" and 3/4" inserts are interchangeable with standard driver body.
- Use on all types of ground rods without deforming ends.
- No heavy tools or ladders required.

Part No.	Description
EGRD58	5' Driver body with insert for up to 5/8" ground rods
EGRD581*	Replacement insert for 5/8" ground rods
EGRD34	5' Driver body with insert for up to 3/4" ground rods
EGRD341*	Replacement insert for 3/4" ground rods

* Both 5/8" and 3/4" inserts fit standard body of EGRD58 or EGRD34.

The Mechanical Hammer

For adverse soil conditions where it is not suitable to hand drive rods or where a greater depth must be achieved, it may be necessary to use power operated aids. For normal applications we recommend the use of medium tools in the 15 to 25 lb. range, with a stroke of approximately 2" to 4" delivering 2200 blows per minute.

Drilling Options

Where driving is difficult or progress is inhibited, it is necessary to use purpose-designed drilling equipment, such as electric, pneumatic and petrol driven machinery capable of penetrating rock. Once the hole is drilled, you can use one of two methods to install the ground rod:

- Backfill the hole with Ground Enhancement Material, and add water to the hole as rod is driven to the required depth.
- Insert the rod into the drilled hole, then add Ground Enhancement Material which has been mixed with water to form a slurry. For more details, see page 30 (GEM installation).



Ground System Components

Ground Electrodes

ERITECH® Copperbonded Pointed Ground Rods

- Copper is molecularly bonded to nickel-sealed high-strength steel cores.
- ERITECH ground rods provide the company name, length, diameter, part number, roll-stamped within 12" of chamfered end and the UL logo and control number where applicable on each rod for easy inspection after installation.
- See specifications on page 69.

Part No.	Plating Thickness (ml.)	Dia. (in.)	Lgth (ft.)
613852	5	3/8	5
613862	5	3/8	6
613880	10	3/8	8
611255	5	Nom. 1/2	5
611265	5	Nom. 1/2	6
611285	5	Nom. 1/2	8
611380*	10	1/2	8
611205	5	Nom. 1/2	10
611300*	10	1/2	10
615850	10	5/8	5
615860	10	5/8	6
615880*	10	5/8	8
615883*	13 - RUS	5/8	8
615800*	10	5/8	10
615803*	13 - RUS	5/8	10
615812*	10	5/8	12
615815*	10	5/8	15
613460	10	3/4	6
613480*	10	3/4	8
613483*	13 - RUS	3/4	8
613400*	10	3/4	10
613412*	10	3/4	12
613415*	10	3/4	15
614400*	10	1	10

*UL Listed rods

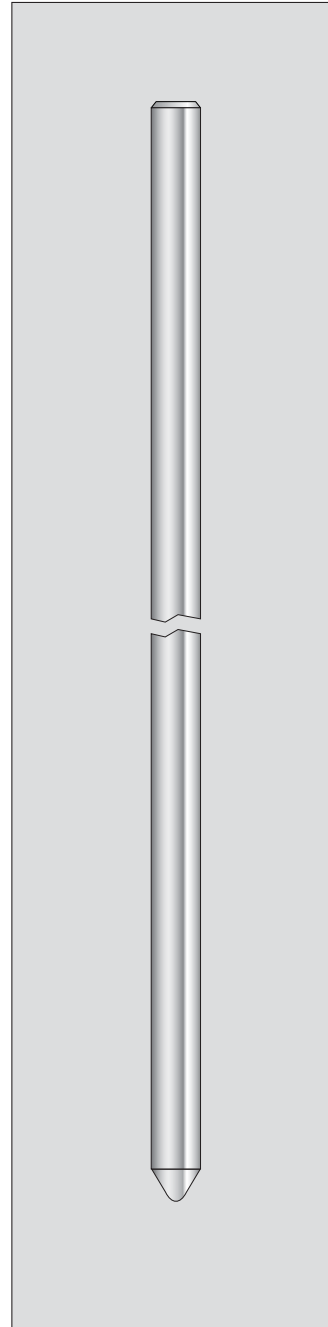

Ground System Components

Ground Electrodes and Accessories

ERITECH® Threadless Couplings for Copperbonded Pointed Rods

- Made of high-strength silicon bronze.
- Tapered so when the rod is driven into the coupling, the two parts compress to form a conductive connection.

Part No.	Nominal Diameter
CC12	1/2" Nominal
CC12F	1/2" Full
CC58	5/8"
CC34	3/4"

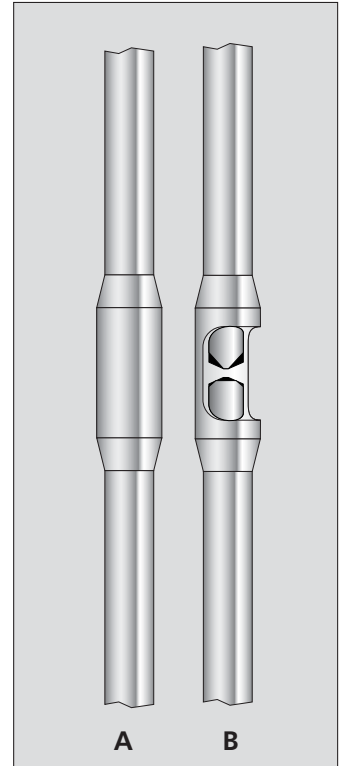
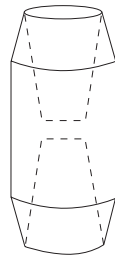
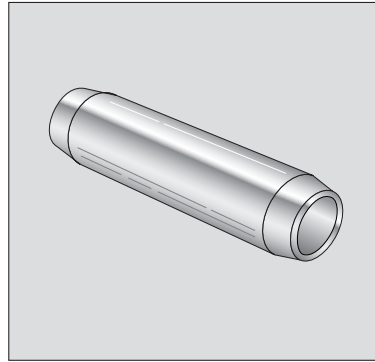

A Compression Coupling – Full View
B Compression Coupling – Cut Away

ERITECH Ground Rod Driving Sleeves*

- Slides on top of ground rod to prevent mushrooming while driving into ground.

Part No.	Ground Rod Size
B137-14	1/2" Copperbonded or Steel Rod
B137-16	5/8" Copperbonded (.563" dia.)
B137-31	5/8" Steel (.625" dia.)
B137-18	3/4" Copperbonded (.682" dia.)
B137-33	3/4" Steel (.750" dia.)
B137-22	1" Copperbonded (.914" dia.)
B137-37	1" Steel (1.00" dia.)

* For plain (unthreaded) ground rods only.

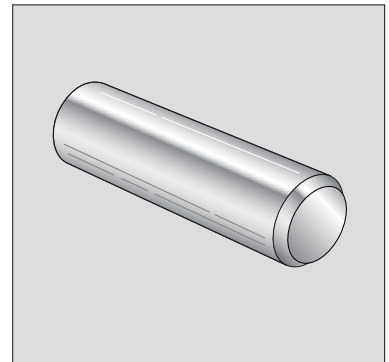
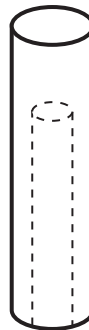

- Sleeves for use in power assisted ground rod drivers.

Part No.	Ground Rod Size (Unthreaded)
DH58	5/8" Copperbonded (.563" dia.)
DH34	3/4" Copperbonded (.682" dia.)

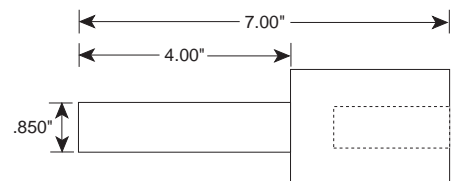

Ground System Components

Ground Electrodes and Accessories

ERITECH® Copperbonded Sectional Ground Rods, Couplings and Driving Studs

- The cold-rolled threads with their continuous unbroken grain flows are stronger than cut-threads.
- High-strength couplings are threaded bronze and chamfered at both ends for easy driving.
- High strength, corrosion-resistant couplings ensure permanent, low resistance copper-to-copper connections.

Part No.	Plating Thickness (ml)	Dia. (in.)	Length (ft.)
631380*	10	1/2	8
631300*	10	1/2	10
635830	10	5/8	3
635840	10	5/8	4
635850	10	5/8	5
635860	10	5/8	6
635880*	10	5/8	8
635883*	13 - RUS	5/8	8
635800*	10	5/8	10
633480*	10	3/4	8
633400*	10	3/4	10
634400*	10	1	10

*UL Listed rods

ERITECH Couplings for Sectional Rods

Part No.	Rod Size
CR-12	1/2" Nominal
CR-12S	1/2" Full Size
CR-58	5/8" Nominal
CR-34	3/4" Nominal
CR-100	1" Nominal

ERITECH Driving Studs for Sectional Rods

Part No.	Rod Size
DS12	1/2" Nominal
FDS12	1/2" Full Size
DS58	5/8" Nominal
DS34	3/4" Nominal
DS1	1" Nominal

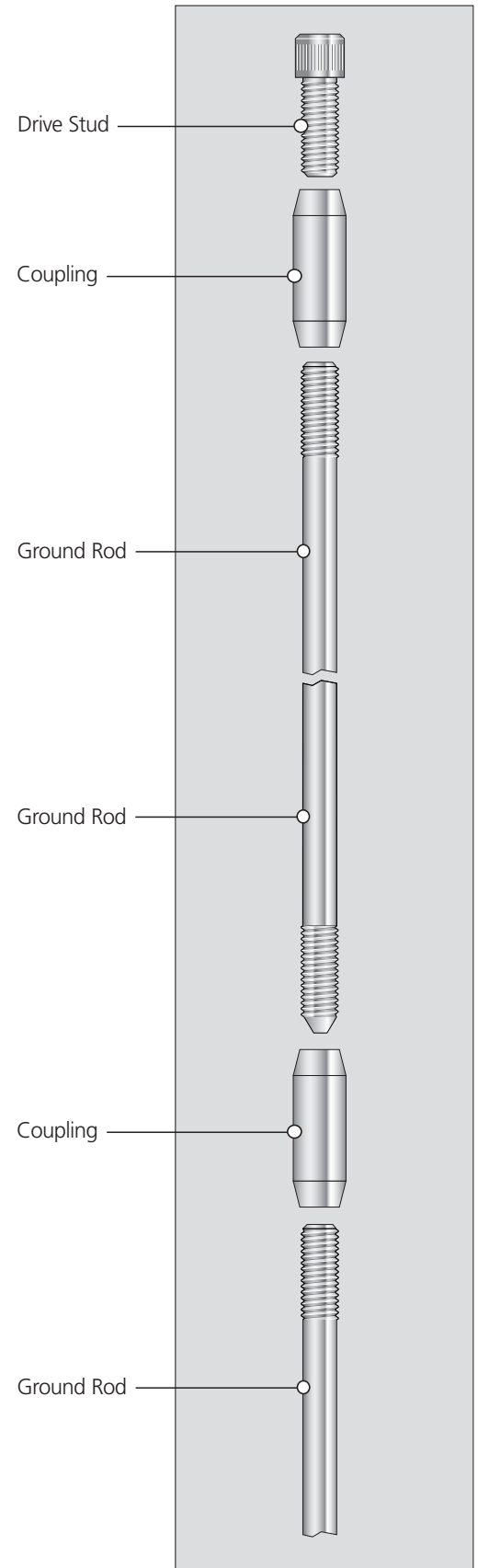

Ground System Components

Ground Electrodes and Accessories

ERITECH® Copperbonded Pigtail Ground Rods

- Pigtails are either Copperweld® or copper wire securely mig-welded to rod.
- Contact ERICO for specific requirement.

Part No.	Nominal Dia X Length	Cu Thickness (Mil.)	Wire
6138529	3/8" x 5'	5 Mil	#10CW x 18" Lg
6138629	3/8" x 6'	5 Mil	#10CW x 18" Lg
615889	5/8" x 8'	10 Mil	#6 AWG Cu x 48" Lg
615809	5/8" x 10'	10 Mil	#6 AWG Cu x 48" Lg
6158839	5/8" x 8'	13 Mil	#6 AWG Cu x 48" Lg
6158039	5/8" x 10'	13 Mil	#6 AWG Cu x 48" Lg

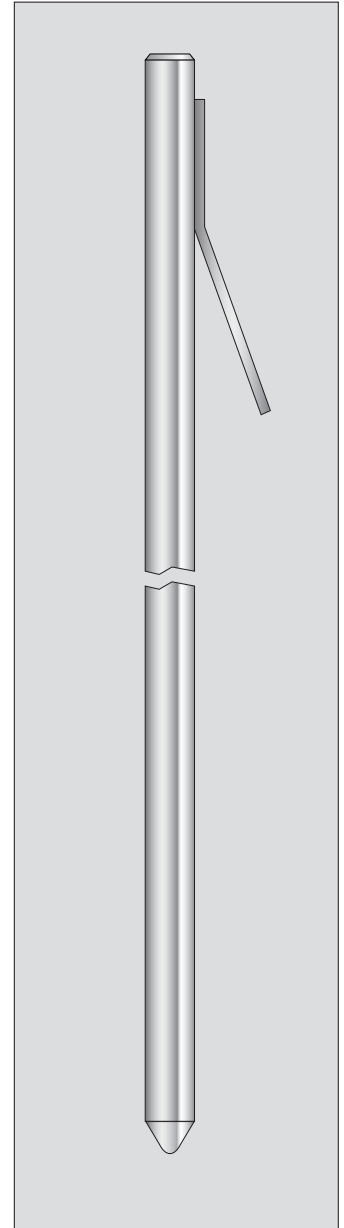

Ground System Components

Ground Electrodes and Accessories

ERITECH® Solid Stainless Steel Ground Rods

- Sectional rods utilize a cut thread for highly corrosive soil.
- Contact ERICO® for other available sizes.

Part No.	Description	Dia. (in.)	Length (ft.)
681300	304 Pointed	FS 1/2	10
683400	304 Pointed	3/4	10
683400S	304 Sectional	3/4	10
685880	304 Pointed	5/8	8
685800	304 Pointed	5/8	10
685880S	304 Sectional	5/8	8
681300S	304 Sectional	1/2	10

ERITECH Threaded Stainless Steel Coupling

Part No.	Description
CR13SS	1/2" Full Size
CR58SS	5/8"
CR34SS	3/4"

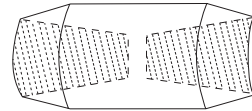

ERITECH Galvanized Pointed Ground Rods

- Meets NEMA, GR1 and is RUS Approved.
- Zinc-coated exteriors are hot-dip galvanized for solid protection against corrosion in accordance with ASTM specification A153-78.
- Surfaces are rigidly inspected to eliminate seams, slivers and other defects.

Part No.	Rod Size
811250	1/2" x 5'
811260	1/2" x 6'
811280	1/2" x 8'
815860	5/8" x 6'
815880*	5/8" x 8'
815800	5/8" x 10'
813480*	3/4" x 8'
813400	3/4" x 10'
814400	1" x 10'

*RUS Approved

ERITECH Galvanized Steel Coupling

Part No.	Rod Type	Rod Size
GCC58	Threadless	5/8"

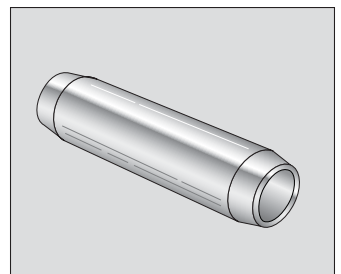
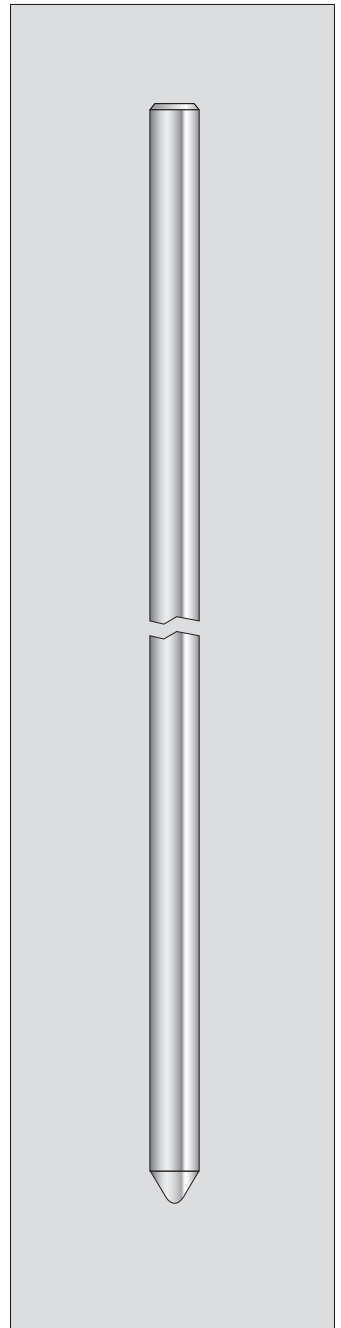
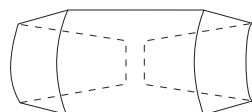

Ground System Components

Ground Electrodes and Accessories

ERITECH® Copper Ground Plate Electrode with Terminated 2 Foot Welded Pigtail Connection

Part No.	Dimensions
GPECEAH24 "xx" 24	12"x24"x20 Ga Cu
GPECEAJ18 "xx" 24	18"x18"x20 Ga Cu
GPECEAJ24 "xx" 24	18"x24"x20 Ga Cu
GPECEAJ36 "xx" 24	18"x36"x20 Ga Cu
GPECEAK24 "xx" 24	24"x24"x20 Ga Cu
GPECEAM36 "xx" 24	36"x36"x20 Ga Cu
GPECEBH12 "xx" 24	12"x12"x1/16" Cu
GPECEBH24 "xx" 24	12"x24"x1/16" Cu



ERITECH Copper Ground Plate Electrode with 2 Foot Welded Through Pigtail Connection

Part No.	Dimensions
GPECCA24 "xx" 24	12"x24"x20 Ga Cu
GPECCAJ18 "xx" 24	18"x18"x20 Ga Cu
GPECCAJ24 "xx" 24	18"x24"x20 Ga Cu
GPECCAJ36 "xx" 24	18"x36"x20 Ga Cu
GPECCA24 "xx" 24	24"x24"x20 Ga Cu
GPECCAM36 "xx" 24	36"x36"x20 Ga Cu
GPECCBH12 "xx" 24	12"x12"x1/16" Cu
GPECCBH24 "xx" 24	12"x24"x1/16" Cu



"xx" - Cable code for required conductor type and size

ERITECH Copper Ground Plates

- Made from 20 gauge thick, high conductivity copper sheet.
- Two cable attachments LPC535L securely fastened to plate.

Part No.	Dimensions
LPC750	12" wide by 24" long
LPC751	18" wide by 18" long
LPC752	36" wide by 36" long

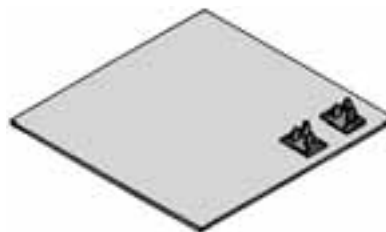

- Cable attachments LPC532L securely fastened to plate.

Part No.	Description
LPC753	12" wide by 24" long
LPC754	18" wide by 18" long
LPC755	36" wide by 36" long

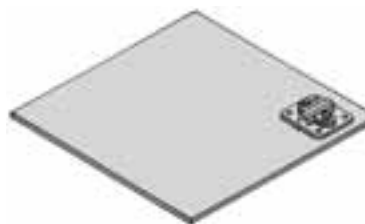

Ground System Components

Ground Electrodes and Accessories

ERITECH® Copper Utility Pole Butt Plate

Part No.	Conductor Range	Plate Diameter
EGP100	#14-#4 AWG	7.5"

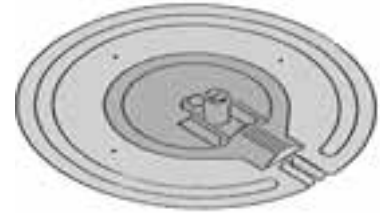

ERITECH Copper Utility Pole Ground Plate

Part No.	Description	Dimensions
GPECEHX1	Copper w/#6 solid ground wire 10' long exothermically welded to plate	1/16"x17"x17"

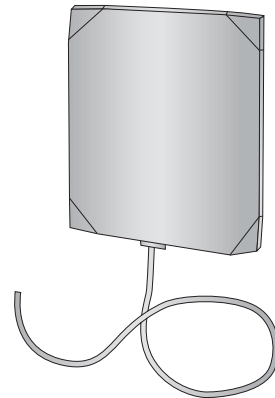

ERITECH Steel Ground Plate Electrode

Part No.	Description	Dimensions
EGGP*	Galvanized steel grounding plate	1/4"x10"x16" w/o connector
EGGPC*	Galvanized steel grounding plate	1/4"x10"x16" w/HDC58 connector
EBGP	Bare steel grounding plate	1/4"x10"x16" w/o connector
EBGPC	Bare steel grounding plate	1/4"x10"x16" w/HDC58 connector

*CSA Listed



Ground System Components

Ground Electrodes and Accessories

Chemical Ground Rod

ERITECH® chemical ground electrodes provide a low impedance ground in locations of high soil resistivity.

Used in conjunction with a bentonite backfill and ERICO's unique GEM material, the ERITECH chemical ground electrode system, provides a method to improve soil resistivity directly surrounding the electrode. It maintains a low ground resistance, maintenance-free installation that dissipates lightning energy and other dangerous electrical fault currents, even in sandy or rocky soil conditions. The Chemical Ground Electrode is useful for providing an effective earth in poor soil conditions where spacing for electrodes is limited.

Benefits and Features

- Contains natural electrolytic salts, which permeate into the surrounding soil to condition the soil and increase its conductivity.
- Low impedance to effectively dissipate lightning and electrical fault currents.
- Over 70 configurations available, other assemblies made to order.
- Easy connection to ground electrode conductor using the factory provided pigtail (up or down orientation)
- Provides decades of reliable services due to rugged construction, and high quality metals with a 30 year minimum service life
- 2-1/8" OD Type K copper pipe, 0.083" wall contains natural electrolytic salts that permeate into the surrounding soil, improving electrode to soil connection.
- Available up to 20 feet in length. Longer rods can be field assembled using 10 foot sections.
- Optional factory attached radial strips are available to reduce impedance to high-frequency lightning energy and to control the direction of the dissipation
- L-shaped rods are available for horizontal installation applications where it is impractical to auger deep vertical holes.

UL and CSA Listed

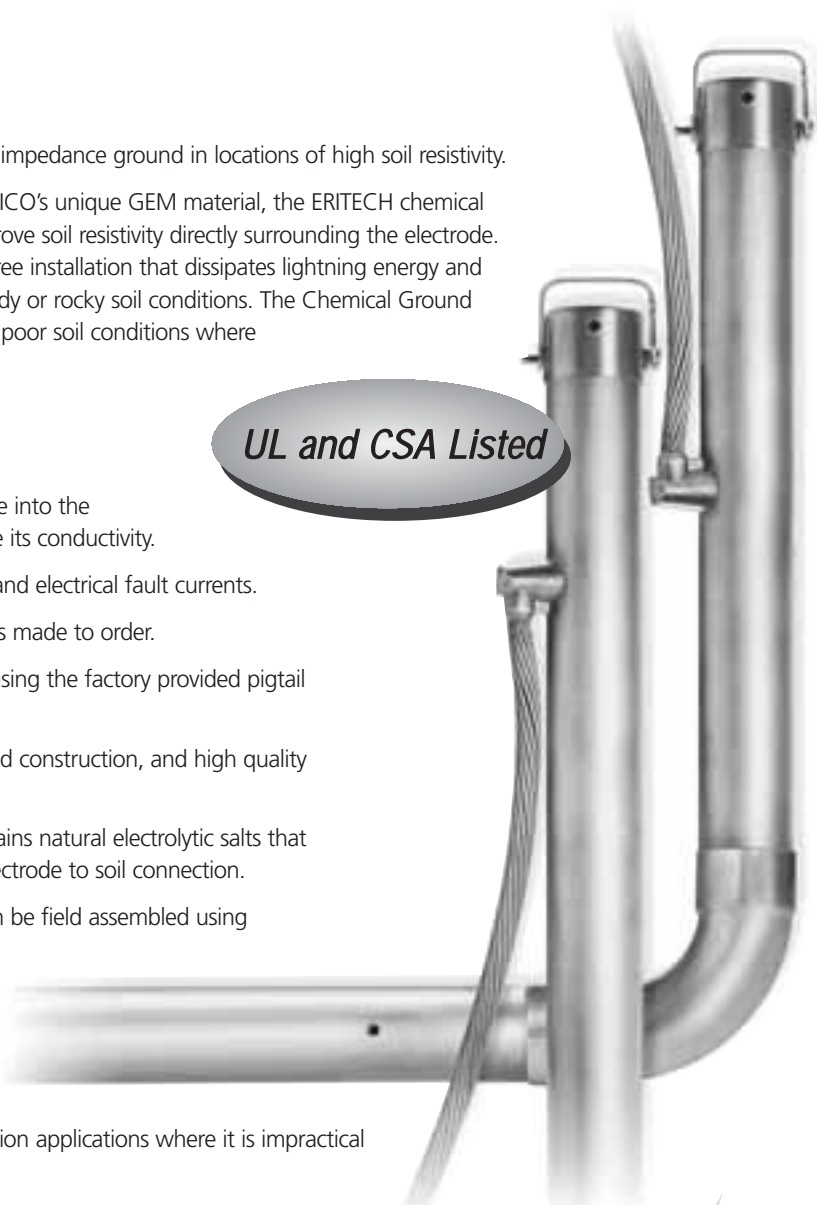

See specification on page 70.

The Chemical Ground Electrode is suitable for high soil resistivity, dry soil conditions, as it can replace multiple conventional ground rods, making the system ideal where space limitations apply. Where seasonal variations cause fluctuations in soil resistivity, the Chemical Ground Electrode ensures a constant and reliable low impedance ground.

Market Applications

- Telecommunications
- Power Generation & Distribution
- Commercial & Industrial
- Manufacturing
- Transport – Rail, Aviation
- Lightning Protection
- Recreational Facilities
- Defense



Ground System Components

Ground Electrodes and Accessories

Chemical Ground Rod

Chemical Ground Electrode System

ERICO® Chemical Ground Electrodes are most effective when installed as part of a total system that includes high conductivity backfill materials, access/inspection wells, and permanent, reliable CADWELD® connections. They may be installed either vertically or horizontally, as shown below in figure 18. ERICO recommends installing the complete system.

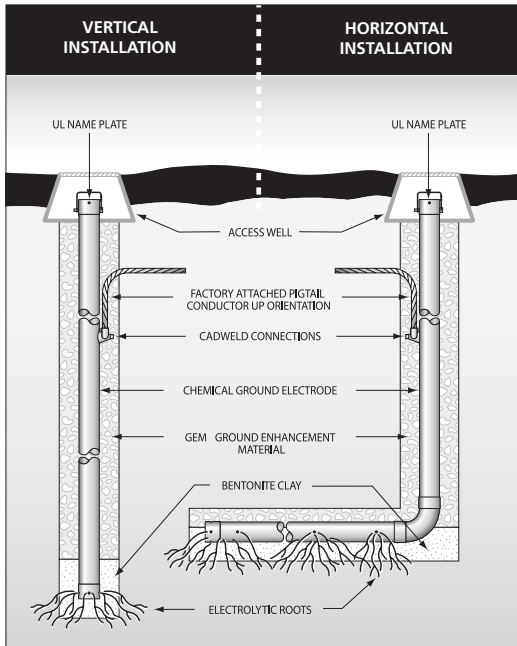

Figure 18. Chemical Ground Electrode can be installed either vertically or horizontally. Chemical electrodes are available in a range of standard and custom configurations and are available individually or as part of a complete kit.

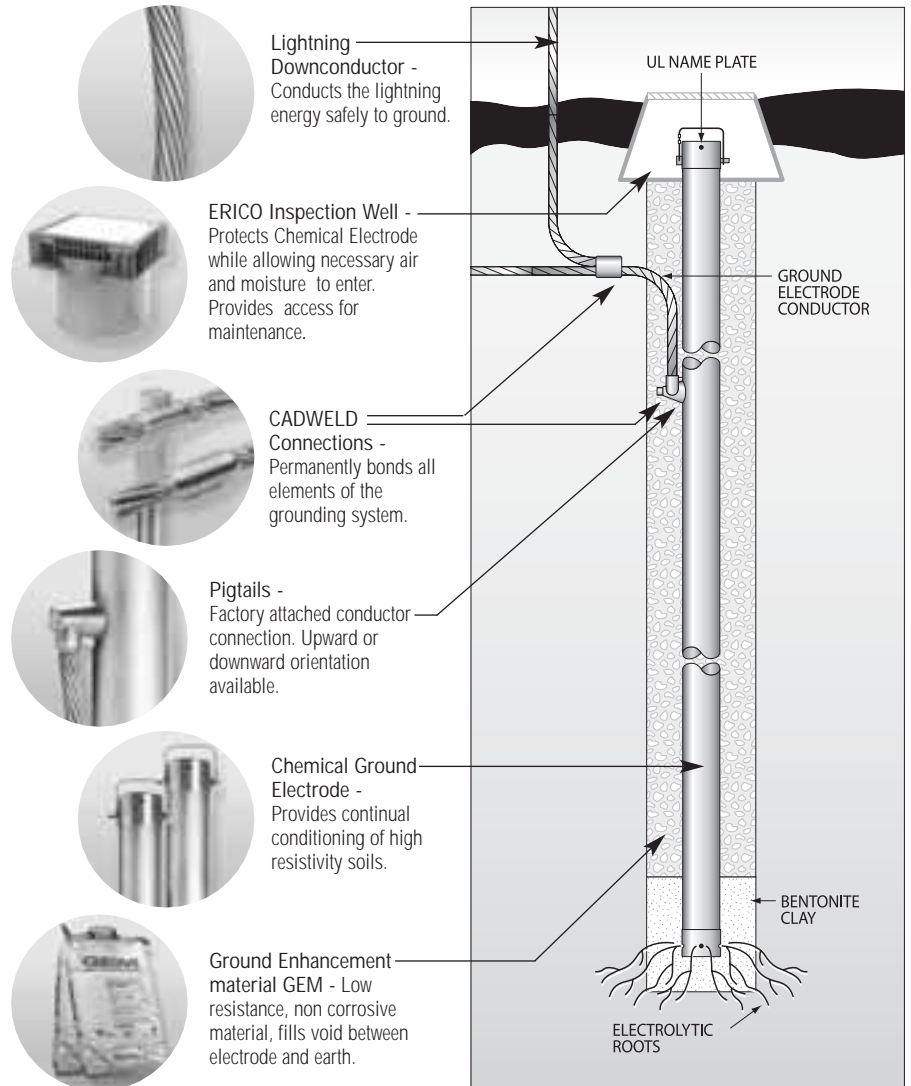
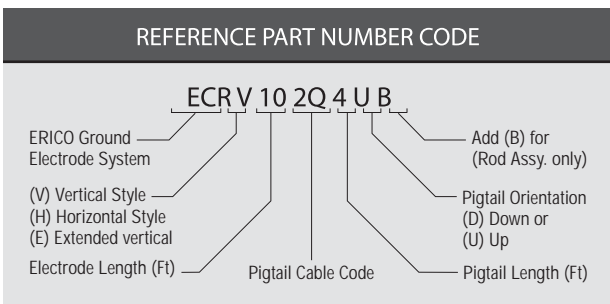

Figure 19. Typical vertical installation showing major components required to form an effective ground electrode.

How to Order

Chemical ground rods can be ordered as individual components or as a complete kit. Kits include the chemical electrode (pre-filled with electrolytic salts), bentonite, GEM backfill and an access well. To order the chemical electrode only, add "B" to the end of the part number.



COPPER CONDUCTOR CODES - Pigtail Conductor

Conductor Code	Size Description	Conductor Code	Size Description
1T	#2 Solid Tinned	2Q	4/0 Conc.
2C	1/0 Conc.	2V	250 Kcmil Conc.
2G	2/0 Conc.	3Q	500 Kcmil Conc.

INDIVIDUAL COMPONENTS

Part No.	Description
(see above)	Chemical ground rod electrode only
GEM25A	25 lg. (11.4 kg) bag of GEM Ground Enhancement Material
BENTFILL	50 lb. (22.7 kg) bag of bentonite
(see catalog #A1A)	CADWELD® material for cable-to-cable connections
T416BH	High-density polyethylene access pit for no traffic areas (type supplied with kits)
T416D	Concrete access well for traffic areas

Ground System Components

Ground Electrodes and Accessories

Ground Enhancement Material (Part# GEM25A)

Only rarely do grounding system designers and contractors get to work on a site with good grounding conditions. Even under ideal circumstances, soil structure can vary and make it difficult to achieve uniform, low levels of resistivity across a wide area. Under almost all soil conditions, the use of a ground enhancement material will improve grounding effectiveness. Some are permanent and require no maintenance. When selecting a ground enhancement material be sure it is compatible with the ground rod, conductor and connection material.

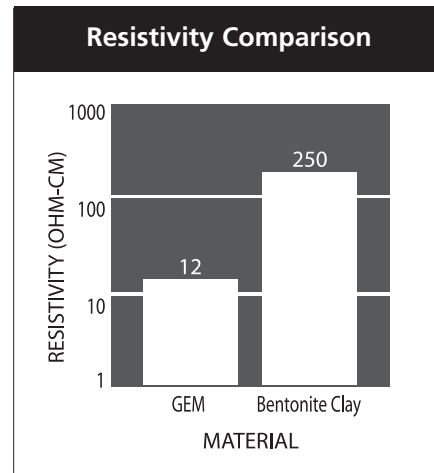

Figure 20. As the graph clearly shows, GEM has a resistivity factor more than 20 times lower than bentonite clay.

To improve the conductivity of a grounding system, ERICO® recommends using Ground Enhancement Material (GEM).

GEM is a low-resistance, non-corrosive, carbon dust based material that improves grounding effectiveness, especially in areas of poor conductivity. GEM contains cement, which hardens when set to provide a permanent, maintenance-free, low-resistant grounding system that never leaches or washes away.

Benefits and Features

No other material matches GEM for reducing earthing resistance and maintaining low resistance permanently. No other material equals GEM in providing conductivity for the life of the grounding system.

GEM is effective

- GEM can dramatically lower earth resistance and impedance measures
- GEM maintains constant resistances for the life of the system once in set form
- GEM performs in soil conditions even during dry spells
- Because it is chemically stable and very low in sulfate and chloride, it protects ground conductors from corrosion instead of attacking them like salts do.

GEM is Permanent

- Does not dissolve, decompose nor leach out with time
- Does not require periodic charging treatments nor replacement
- Does not require maintenance
- Does not require continuous presence of water to maintain effectiveness
- Freezing will increase resistivity by only 10-15 percent

GEM is Environmentally Friendly

- Does not adversely affect the soil
- Does not leach ions or contaminate ground water
- Meets (USA) Environmental Protection Authority requirements for landfill

Application

GEM improves grounding effectiveness regardless of soil conditions and provides excellent permanent conductivity:

- For areas with high resistance, such as rocky ground, mountain tops, and sandy soil
- As a backfill when you have to drill because the ground is too hard to drive, or where ground rods cannot be driven, or
- Where limited space makes adequate grounding difficult by conventional methods



Ground System Components

Ground Electrodes and Accessories

GEM INSTALLATION

GEM is supplied in easy-to-handle 25 lb. bags for one-man installation. GEM can be installed dry or wet (recommended). GEM quickly absorbs moisture from the soil when used dry, to reach its maximum conductivity in days. To accelerate curing time, water can be added after GEM is installed, or it can be pre-mixed with water.



Ask ERICO for a complimentary Six Point Plan CD that includes the GEM calculator to determine the amount of GEM required for your grounding application.

TRENCH INSTALLATION

1. Dig a trench at least 4 inches wide x 30 inches deep or below the frost line, whichever is deeper. Spread out enough GEM to uniformly cover bottom of trench-about 1 inch deep.
2. Place conductor on top of GEM.
3. Spread more GEM on top of conductor to completely cover conductor about 1 inch deep.
4. Carefully cover the GEM with soil to a depth of about 4 inches, making sure not to expose the conductor. Tamp down the soil, then fill in the trench. For various trench widths and GEM thicknesses, see the table on page 28.

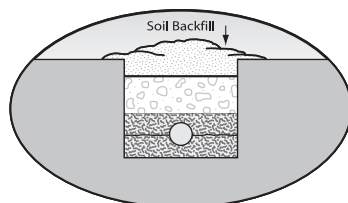
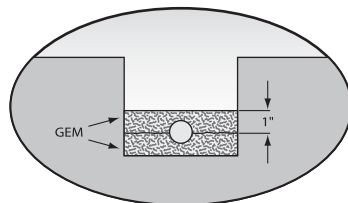
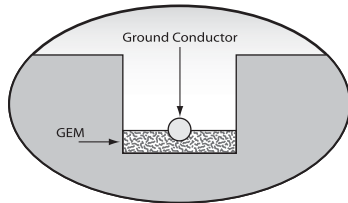
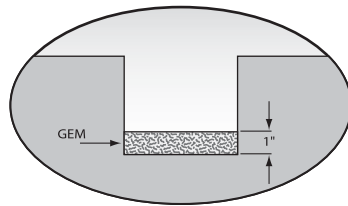

Figure 21.

GROUND ROD BACKFILL INSTALLATION

1. Auger a 3 inch or larger diameter hole to a depth of 6 inches less than the length of the ground rod.
2. Place ground rod into augered hole and drive one foot (if possible) into bottom of the hole. The top of the ground rod will be approximately 6 inches below grade. At this time, make any connections to ground rod using CADWELD connections.
3. Pour the appropriate amount of GEM around the ground rod. To ensure the GEM material completely fills the hole, tamp around the ground rod with a pole.
4. Fill remainder of augered hole with soil removed during augering. For various augered-hole diameters and depths, see the table on page 28.

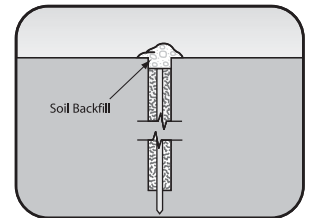
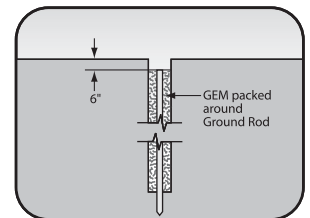
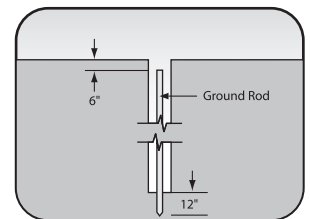
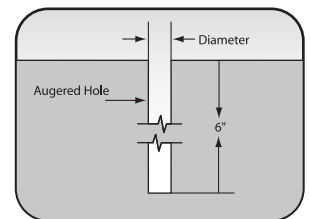

Figure 22.

Note: If premixing GEM into a slurry form, use a standard cement mixer or hard-mix in a mixing box, wheelbarrow, etc. Use 1-1/2 to 2 gallons of clean water per bag of GEM.

Note: Excess standing water must be removed from the hole.

Ground System Components

Ground Electrodes and Accessories

TRENCH INSTALLATION

Estimated linear feet of ground conductor covering with each bag of GEM

Trench Width	Total Thickness of GEM			
	1" (2.5cm)	2" (5.1cm)	3" (7.6cm)	4" (10.2cm)
4" (10.2cm)	14.0 (4.3m)	7.0 (2.1m)	4.7 (1.4m)	3.5 (1.1m)
6" (15.2cm)	9.3 (2.8m)	4.7 (1.4m)	3.1 (0.9m)	2.3 (0.7m)
8" (20.3cm)	7.0 (2.1m)	3.5 (1.1m)	2.3 (0.7m)	1.8 (0.5m)
10" (25.4cm)	5.6 (1.7m)	2.8 (0.9m)	1.9 (0.6m)	1.4 (0.4m)
12" (30.5cm)	4.7 (1.4m)	2.3 (0.7m)	1.6 (0.5m)	1.2 (0.4m)

A 25-pound bag of GEM will cover 7 linear feet (2.1m) of conductor length for a 4-inch-wide (10.2cm), 2-inch-thick (5.1cm) covering [1 inch (2.5cm) below and 1 inch (2.1cm) above conductor], based on 63.5 lb/cu ft (1017^{kg}/m³).

GROUND ROD BACKFILL INSTALLATION

Estimated bags of GEM for backfilling around ground rods to a density of 90 lb/cu ft (1442kg/m³)

Dia. of hole	Depth of hole (feet)*						
	6' (1.8m)	7' (2.1m)	8' (2.4m)	9' (2.7m)	17' (5.2m)	19' (5.8m)	20' (6.1m)
3" (7.6cm)	2	2	2	2	4	4	4
4" (10.2cm)	2	3	3	3	6	7	7
5" (12.7cm)	3	4	4	5	9	10	10
6" (15.2cm)	5	5	6	7	13	14	15
7" (17.8cm)	6	7	8	9	17	19	20
8" (20.3cm)	8	9	11	12	22	25	26
9" (22.9cm)	10	12	13	15	28	31	32
10" (25.4cm)	12	14	16	18	34	38	40

*8-foot (2.44m) minimum rod length required to be in contact with the soil (or GEM). Per NEC 250-52.

How to Specify GEM

- Ground enhancement material must be permanent and maintenance-free (no recharging with salts or chemicals which may be corrosive) and maintain its earth resistance with time.
- It must set up firmly and not dissolve or decompose or otherwise pollute the soil or the local water table.
- The ground enhancement material shall be suitable for installation in dry form, or in slurry form.
- The ground enhancement material shall not depend on the continuous presence of water to maintain its conductivity.
- Ground enhancement material in its set form shall have a resistivity of not more than 20 ohm-cm.



Figure 23. GEM permanent ground enhancement material, is ideal in areas of poor conductivity and is suitable for both backfilling around ground rods and trench installations.

Ground System Components

Ground Electrodes and Accessories

Ground Inspection Wells

For periodically measuring the electrical resistance of a buried ground system, inspection wells are used as a means of access to the ground conductor. To make electrical resistance measurements, remove the cover and attach a lead from a resistance measuring instrument to the ground conductor.

Inspection wells are available in various sizes and materials. Light-duty units are generally used. For areas of high vehicular traffic, you should use heavy-duty inspection wells.

Figure 24.

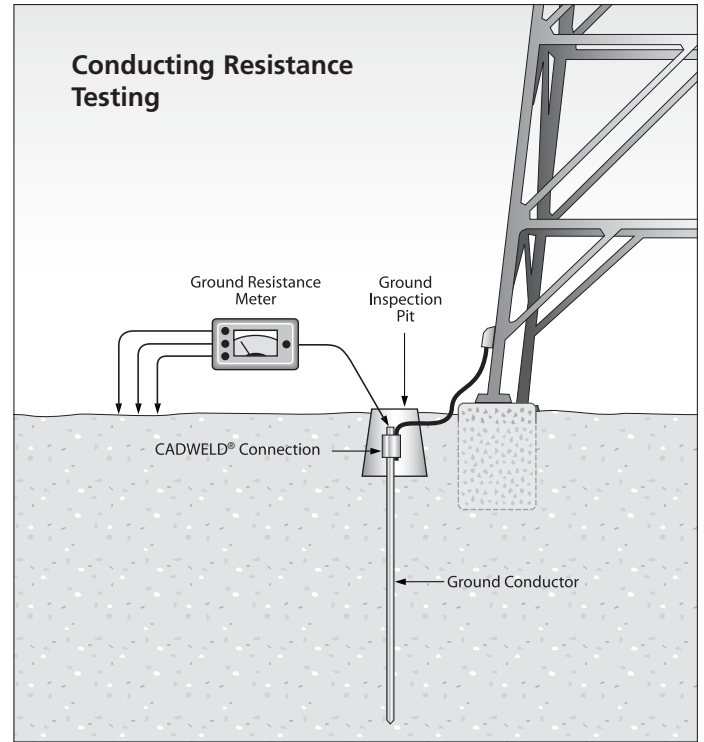
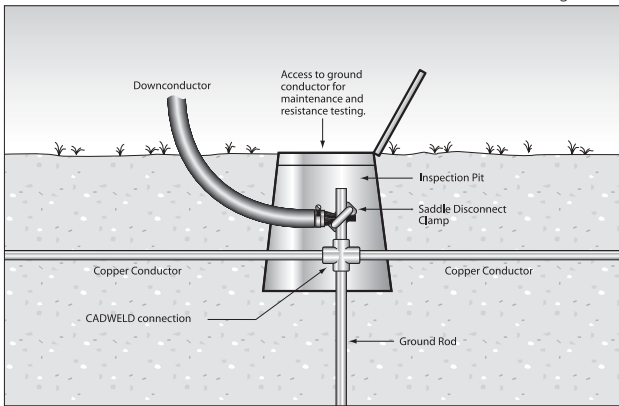
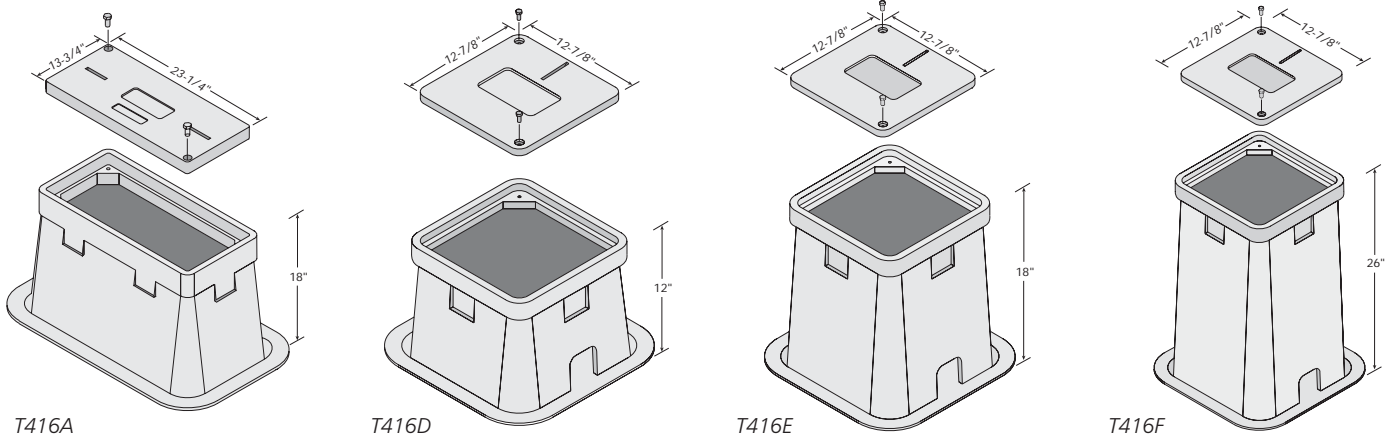

Figure 25. Resistance testing using a ground resistance meter, with access to the ground conductor provided by the ground inspection well.

ERITECH® Polymer Concrete Wells

Part No.	Material	Color	Dimensions	Cover Weight	Box Base with Inserts Weight	Features
T416A	Polymer Concrete*	Concrete Gray	14" x 23" x 18" deep	25 lbs.	50 lbs.	Bolt down cover; skid resistant surface
T416D	Polymer Concrete*	Concrete Gray	13" x 13" x 12" deep	25 lbs.	50 lbs.	Bolt down cover; skid resistant surface
T416E	Polymer Concrete*	Concrete Gray	13" x 13" x 18" deep	25 lbs.	50 lbs.	Bolt down cover; skid resistant surface
T416F	Polymer Concrete*	Concrete Gray	13" x 13" x 26" deep	25 lbs.	50 lbs.	Bolt down cover; skid resistant surface

*Polymer Concrete reinforced with heavy weave fiberglass resulting in high strength and minimal weight. Enclosures and covers rated for 10,000 lbs. maximum load.



Ground System Components

Ground Electrodes and Accessories

ERITECH® High Density Polyethylene Wells

Part No.	Material	Color	Dimensions	Cover Weight	Box Base with Inserts Weight	Features
T416B	High Density Polyethylene	Green	10" round x 10" deep	1-1/2 lbs.	3 lbs.	Stainless steel lock bolt (3/8"-16 x 1-3/4"); very resistant to acids and chemicals; boxes and covers nest in 3-1/4" increments; 2 knockouts per box (3-1/2" x 1-1/2")
T416C	High Density Polyethylene	Black	14" round x 18" deep	4-1/4 lbs.	13.4 lbs.	Resistant to acids and chemicals; pipe slot (2 places)

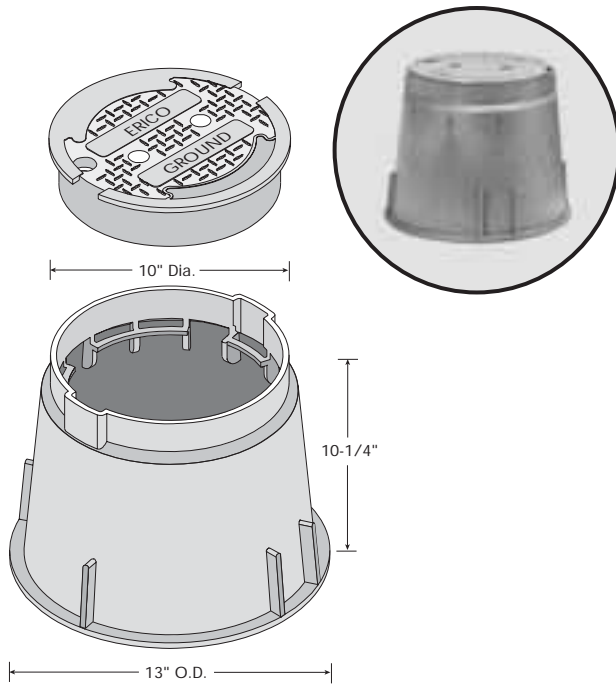

T416B

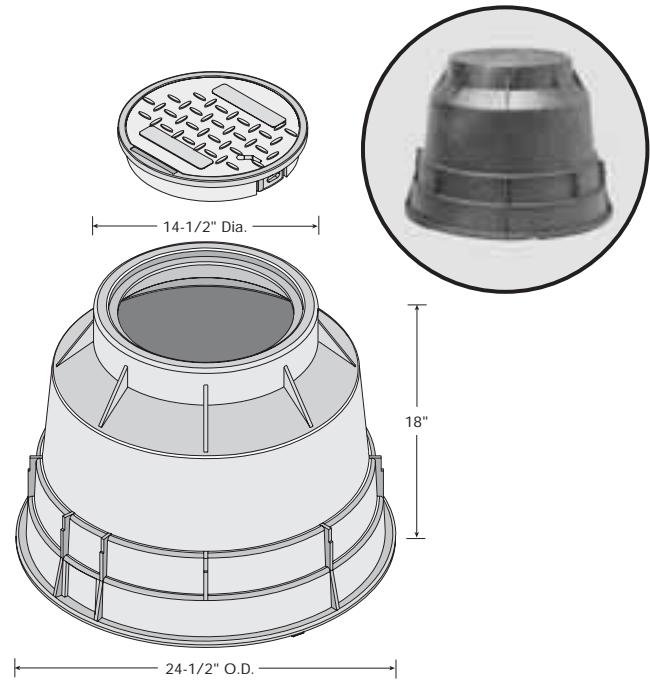

T416C



Equipotential Bonding

Introduction

Equipotential Bonding

Although closely related to grounding, bonding is a distinct discipline that is essential to the overall facility electrical protection scheme. Grounding provides the actual physical connection to earth used for establishing and maintaining its potential, theoretically 0 volts. Bonding is the practice of establishing an equipotential plane by permanently joining together metal parts of the wiring system as well as tying together all of the electrical service grounds. Proper bonding

establishes a low impedance fault return path that allows for the proper operation of over-current devices. Additionally, bonding of all ground electrode systems (main power, telecommunications, and lightning protection) eliminates dangerous potential differences that can arise during fault and transient voltage conditions jeopardizing people and equipment. Bonding of separate ground electrode systems is required by the NFPA (The NEC®) as well as other international electric codes.

The Importance of a Correctly Bonded Ground System

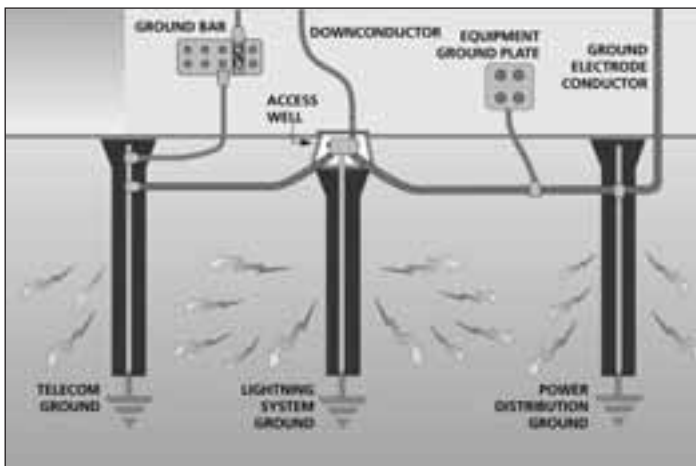

Figure 26.

Figure 26 shows an example of a well-designed grounding system with a "single point" connection of equipment power, lightning protection, and communication ground wires to the ground-ring.

If lightning hits the air terminal on the facility, the lightning protection earth would rise equipotentially with all other ground points as they are closely bonded together. Bonding provides little opportunity for potential differences between ground points creating ground loops or causing sparking or sideflashing.

A non-ideal system can include multiple connection points to the ground-ring and / or poor bonding connections. Figure 27 shows a case where an incoming power feed was effected by lightning. Adequate protection equipment on both power and communications interface was provided, however the separate electrical and communications earths are located some distance apart.

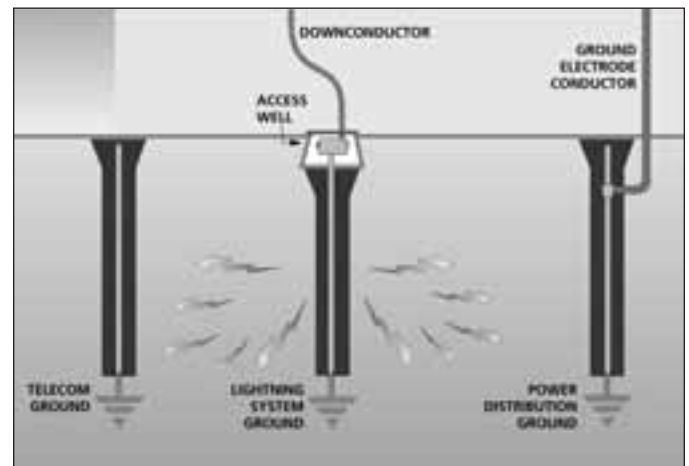

Figure 27.

Figure 27. A non-ideal grounding system uses multiple connection points.

Regardless of how good each individual ground is, for a very short period of time the potential of the electrical ground will be higher than the communications ground. As a result the excess energy has two paths to follow to reach the lower potential communications ground, thus creating a dangerous ground loop that will damage the sensitive electronic equipment in the equipment room. ERICO® provides a number of technologies to assist in the construction of effective "best practice" equipotential grounding systems including the Transient Earth Clamp and the Insulated Joint Protector.

Equipotential Bonding

Equipment Ground Bars

Proper bonding is essential to create an equipotential plane between service grounds and equipment during fault and transient conditions. This equipotential plane provides a near zero voltage differential and serves to protect people and equipment during these events. The most popular bonding product in use today is the ground bar or bonding bar. Ground bars provide a convenient, single-point grounding and bonding location. Conductors are welded to the bar using the CADWELD® process or are mechanically fastened by using lugs.

ERICO® can design and manufacture custom bars. In addition, the breadth of the product offering includes TMGB bars, which meet the requirements of TIA/EIA 607 and conform to BICSI recommendations. Our perimeter bus system allows for fast and easy field installation of halo and other perimeter grounding schemes.

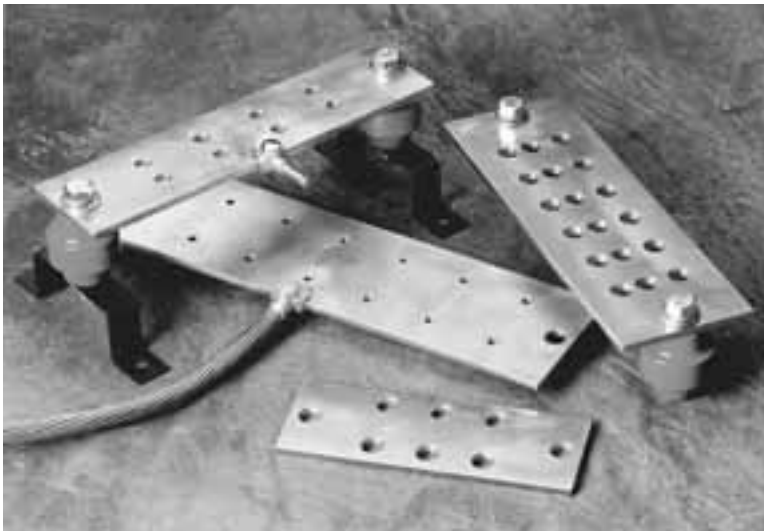

Figure 28.

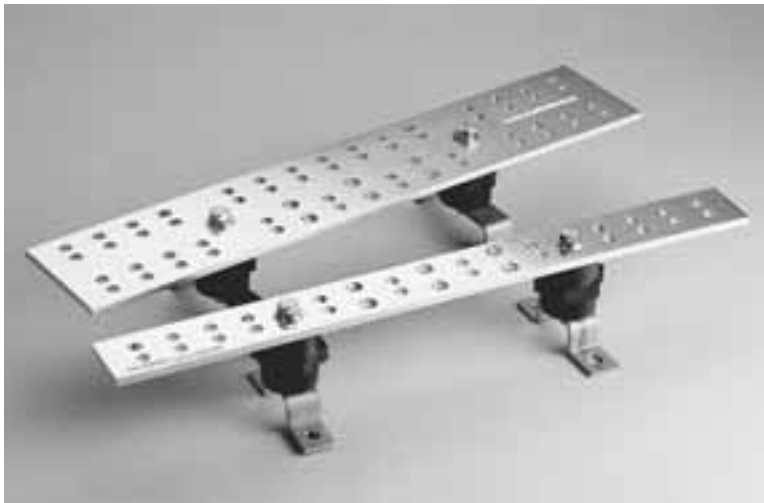

Figure 29.

ERITECH® EGB Series

Materials

Busbars

- 1/4" thick copper
- ASTM B187-C11000
- Electro-tin plated (if required)

Insulators:

- Material: flame resistant fiberglass reinforced thermoset polyester
- Color: red
- Indoor rating: 600 volts
- 1-1/2" height

Brackets:

- Type 304 stainless steel
- 1/8" thick

Fasteners:

- 3/8" Type 304 stainless steel fasteners and stainless steel brackets

ERITECH TGB & TMGB

Materials

Busbars:

- 1/4" thick copper
- ASTM B187-C11000
- Electro-tin plated

Insulators:

- Manufactured of rugged polyamide, an environmentally friendly, halogen-free nylon material which is reinforced with glass fiber
- 2" standoff height
- Meets the requirements of UL94 VO for self-extinguishing materials

Brackets:

- Type 304 stainless steel
- 1/8" thick

Fasteners:

- Type 304 stainless steel

Equipotential Bonding

Equipment Ground Bars

ERITECH® EGB Series
PART NUMBERING SYSTEM

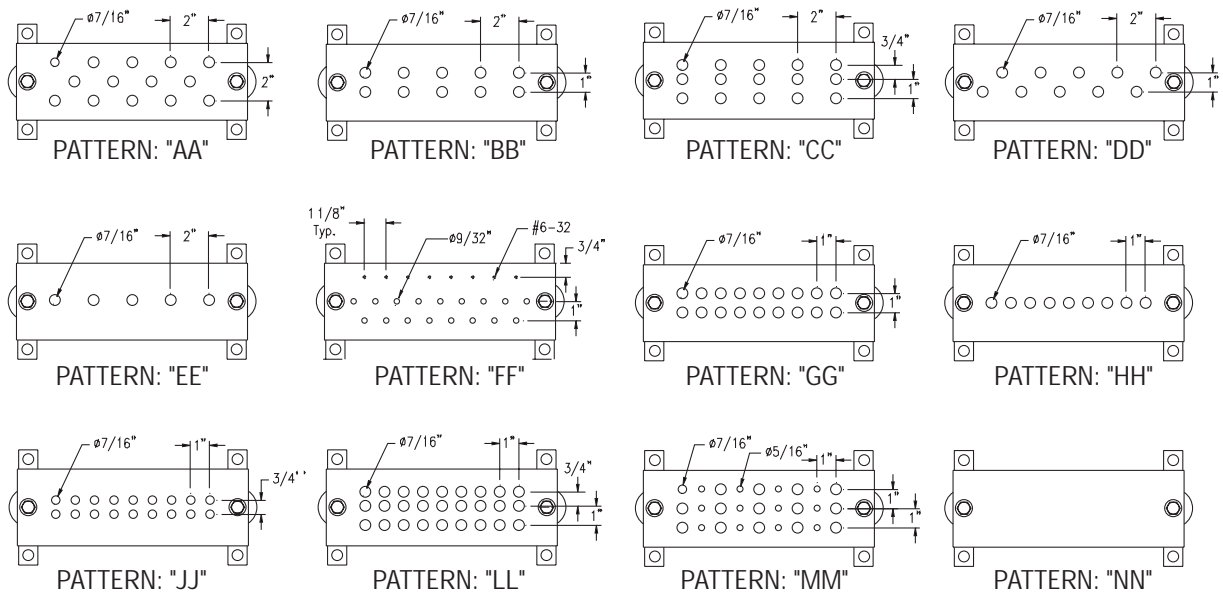
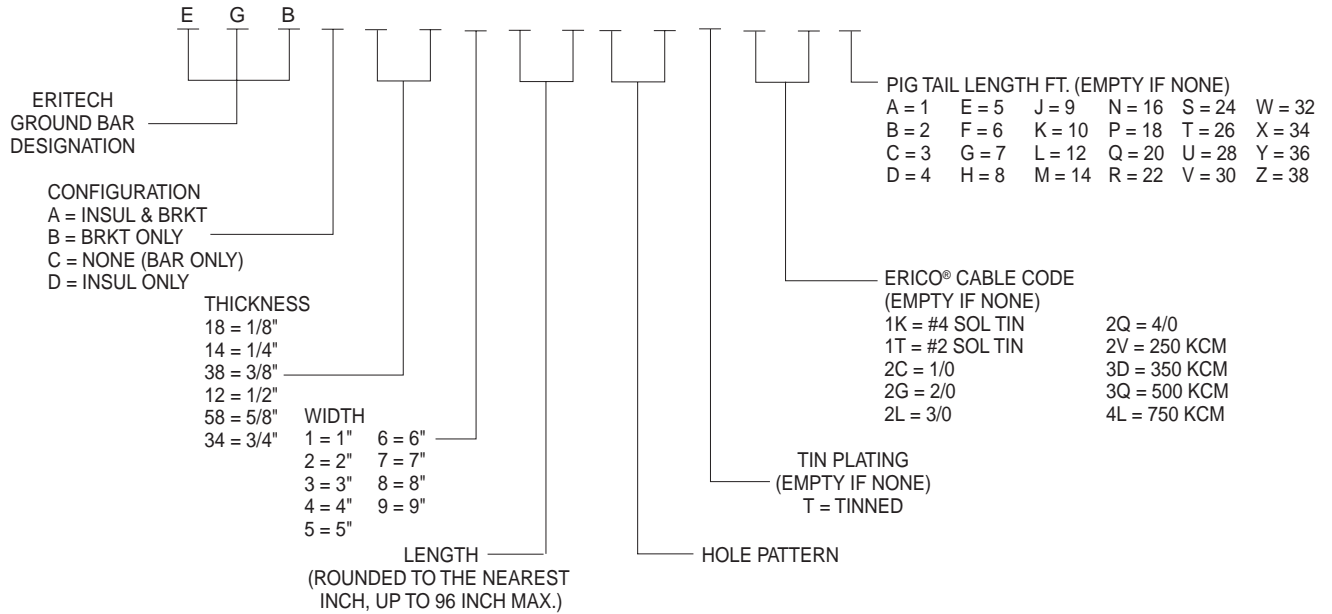
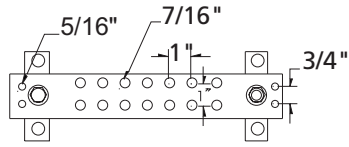

Figure 30.

Equipotential Bonding

Equipment Ground Bars

ERITECH® EGB Series



EGBA14212TES (1/4 x 2 x 12)

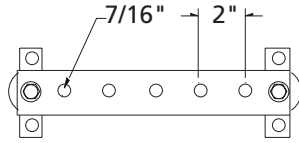

EGBA14212EE (1/4 x 2 x 12)

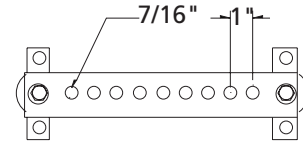

EGBA14212HH (1/4 x 2 x 12)

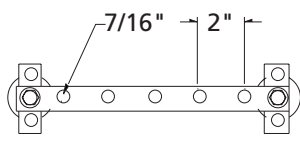

EGBA14112EE (1/4 x 1 x 12)

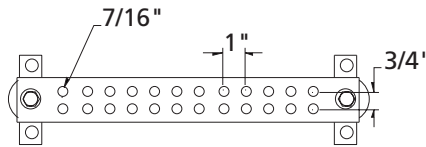

EGBA14215JJ (1/4 x 2 x 15)

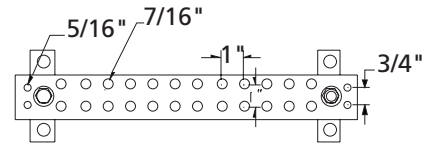

EGBA14215TES (1/4 x 2 x 15)

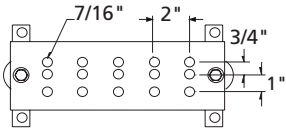

EGBA14412CC (1/4 x 4 x 12)

EGBA14412CCT (1/4 x 4 x 12 tinned)

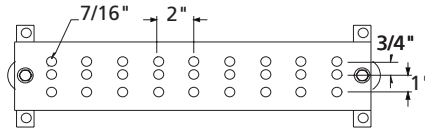

EGBA14420CC (1/4 x 4 x 12)

EGBA144120CCT (1/4 x 4 x 12 tinned)

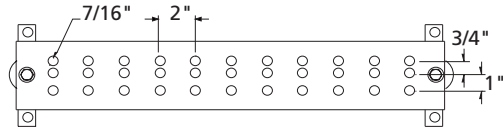

EGBA14424CC (1/4 x 4 x 12)

EGBA144124CCT (1/4 x 4 x 12 tinned)

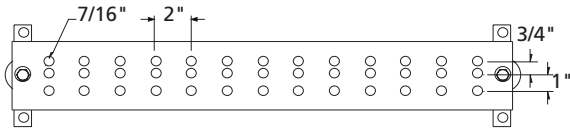

EGBA14428CC (1/4 x 4 x 28)

EGBA144128CCT (1/4 x 4 x 28 tinned)

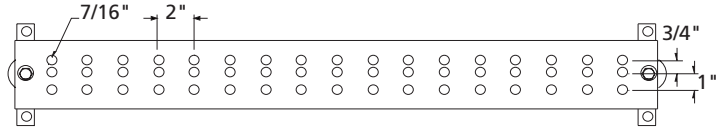

EGBA14436CC (1/4 x 4 x 36)

EGBA144136CCT (1/4 x 4 x 36 tinned)

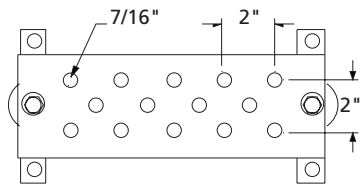

EGBA14412AA

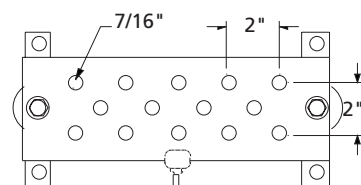

EGBA14412AA1TT (1/4 x 4 x 12 tinned)

(#2 tinned sol pigtail 25ft lg)

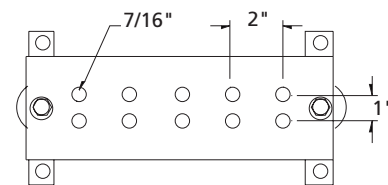

EGBA14412BB (1/4 x 4 x 12)

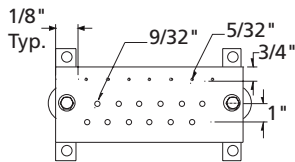

EGBA14410FF (1/4 x 4 x 10)

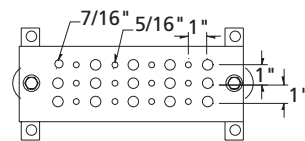

EGBA14412MM (1/4 x 4 x 12)

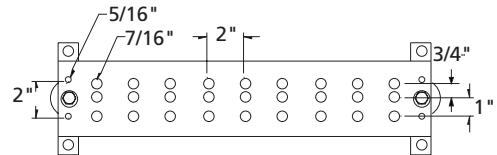

EGBA144120CCSKY (1/4 x 4 x 20)

Figure 31.



Equipotential Bonding

Equipment Ground Bars

ERITECH® EGB Series (cont.)

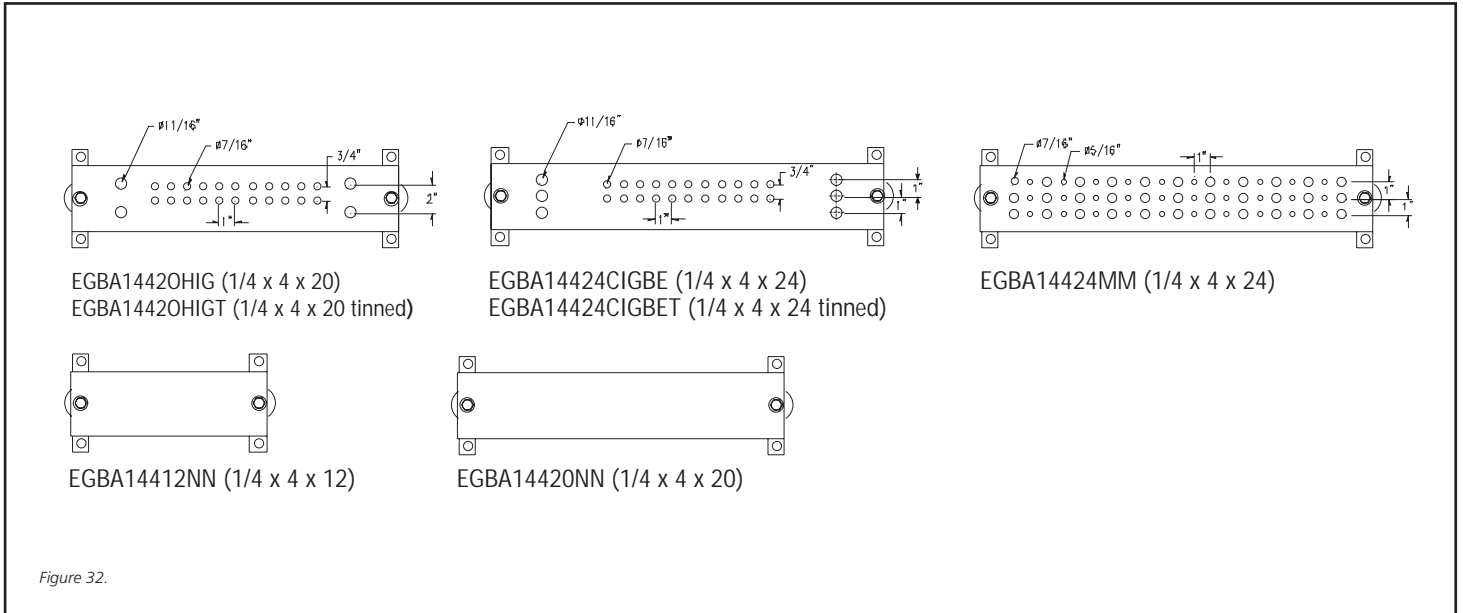

Figure 32.

ERITECH B540 Series

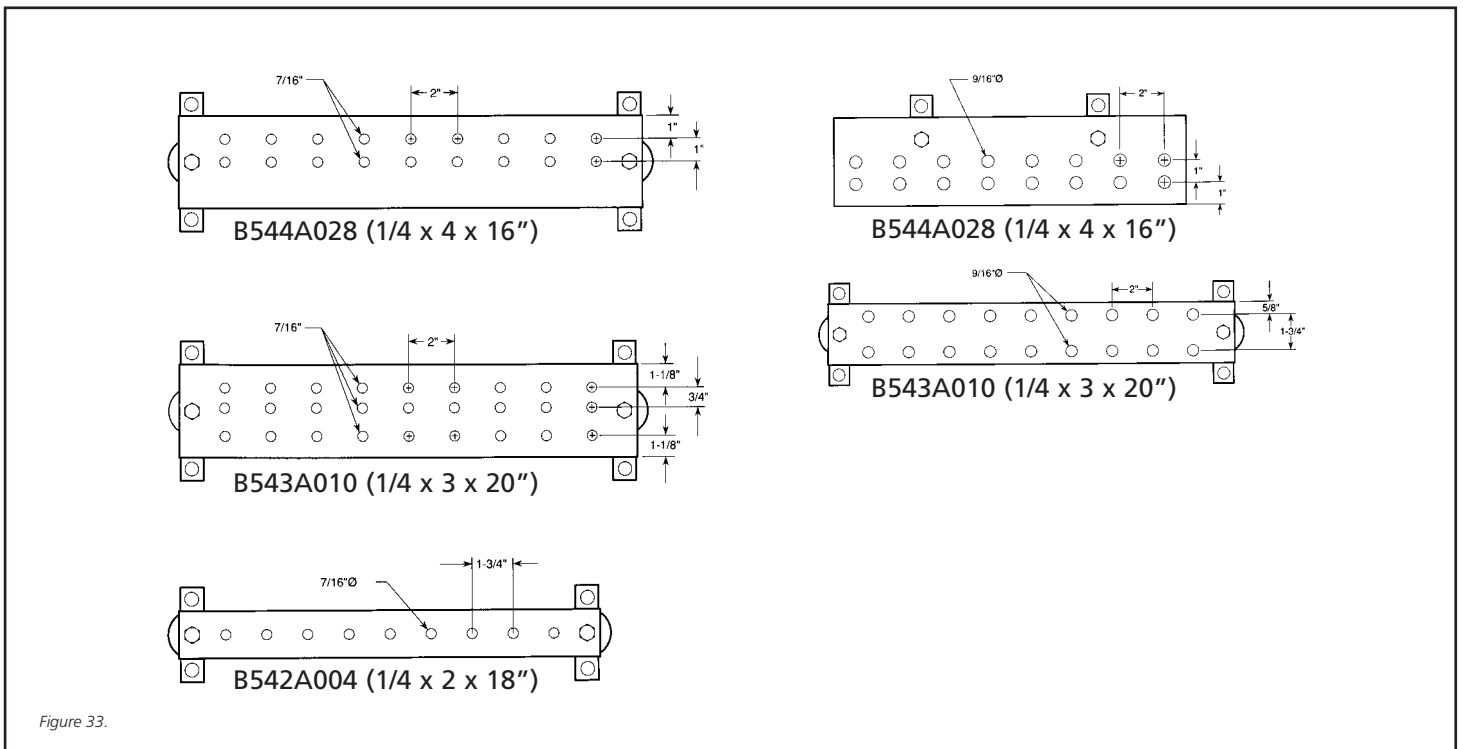

Figure 33.

Equipotential Bonding

Equipment Ground Bars

ERITECH® TGB & TMGB Series



PART NUMBERING SYSTEM

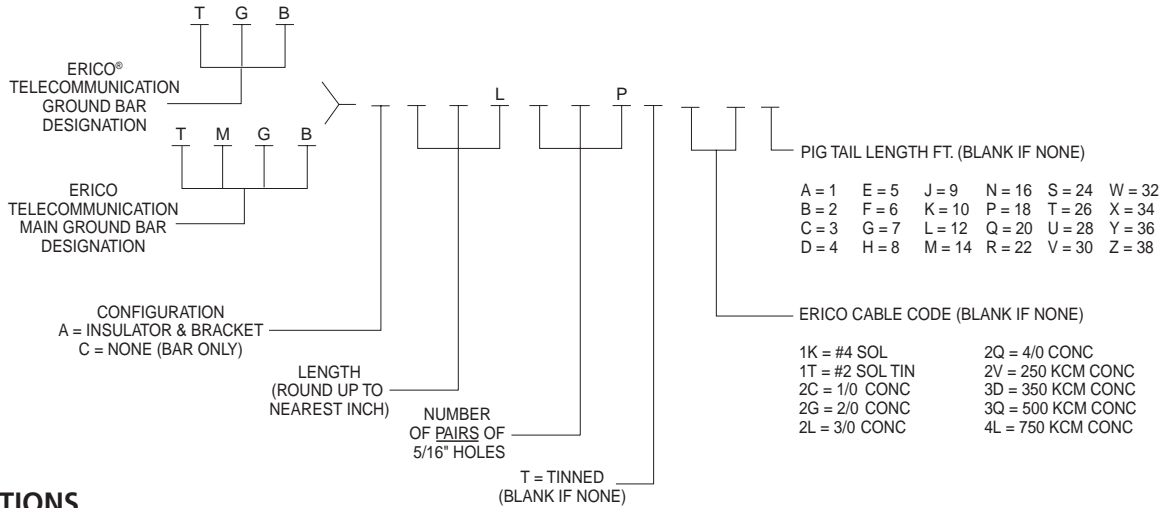

SPECIFICATIONS

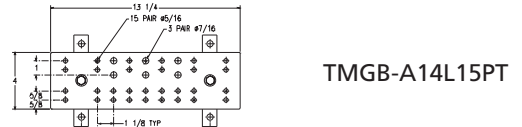
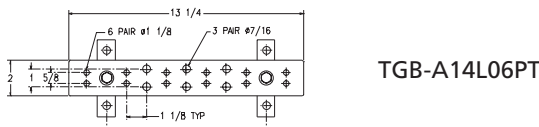
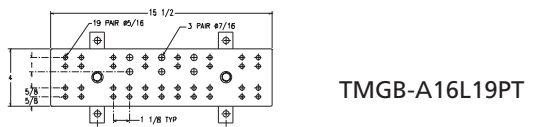
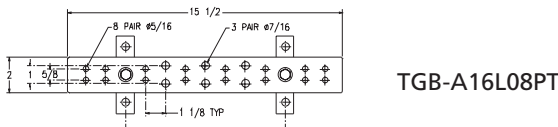
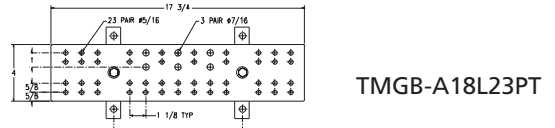
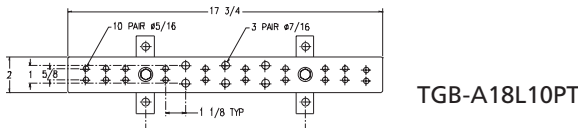
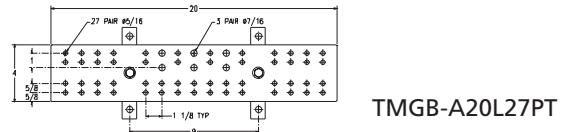
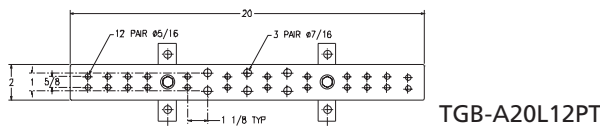
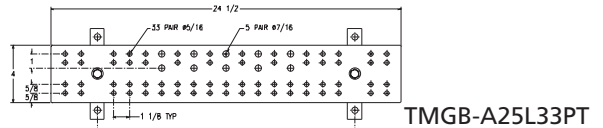
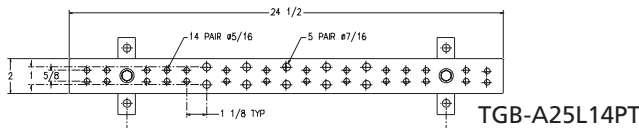
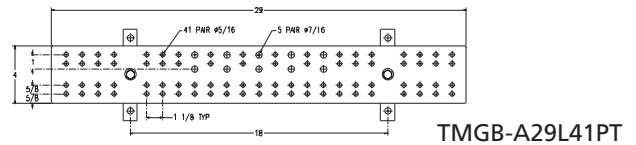
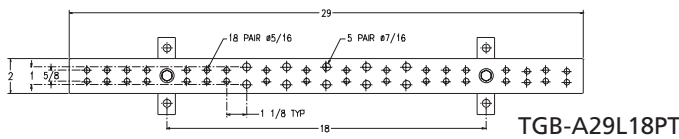

Figure 34.



Equipotential Bonding

Equipment Ground Bars

ERITECH® Splice Kits

Part No.	Description
TGB - SPLICEKIT	Includes plates and fasteners for splicing two TGB busbars
TMGB - SPLICEKIT	Includes plates and fasteners for splicing two TMGB busbars

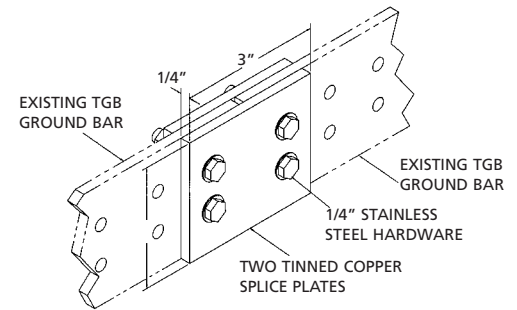

ERITECH Mounting Kits

Part No.	Description
B548A41	Mounting Kit for 1" & 2" Wide Bars, Stainless Steel Hdw & 3/8" Fasteners, Insulator and Bracket
B548A42	Mounting Kit for 3" & 4" Wide Bars, Stainless Steel Hdw & 3/8" Fasteners, Insulator and Bracket

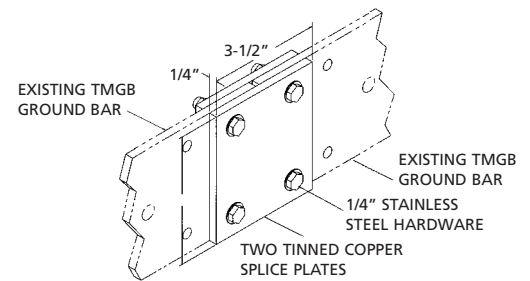

ERITECH Insulators

Part No.	Description
B546A07	Insulator, 1" Lg x 1.125" Dia, 1/4-20 x 5/16" Deep Insert, Fiberglass Reinforced Thermoset Polyester
B546A09	Insulator, 1.25" Lg x 1.125" Dia, 1/4-20 x 5/16" Deep Insert, Fiberglass Reinforced Thermoset Polyester
B546A06	Insulator, 1.375" Lg x 1.75" Dia, 1/4-20 x 5/16" Deep Insert, Fiberglass Reinforced Thermoset Polyester
B546A02	Insulator, 2.25" Lg x 2" Dia, 1/4-20 x 5/16" Deep Insert, Fiberglass Reinforced Thermoset Polyester
B546A01	Insulator, 2.25" Lg x 2" Dia, 1/4-20 x 5/16" Deep Insert, Fiberglass Reinforced Thermoset Polyester
B546A10	Insulator, 2.125" Lg x 2.5" Dia, 1/4-20 x 5/16" Deep Insert, Fiberglass Reinforced Thermoset Polyester



ERITECH FAA Ground Bar

Part No.	Size	Description
B540A130	1/4 x 4 x 12	Electronic Main Ground Bar
B540A131	1/4 x 4 x 8	Electronic Multi Point Ground Bar
B540A132	1/4 x 4 x 6	Electronic Single Point Ground Bar

ERITECH Plexiglass Protective Covers

Part No.	Size
B540C130C	1/4 x 6 x 14
B540C131C	1/4 x 6 x 10
B540C132C	1/4 x 6 x 10

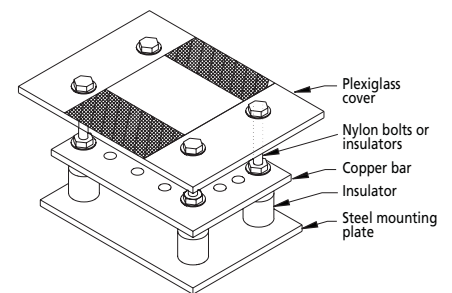

CUSTOM GROUND BAR (FAA STYLE)

Contact ERICO for specific requirements

Equipotential Bonding

Perimeter Bus System

ERITECH® Perimeter Bus System

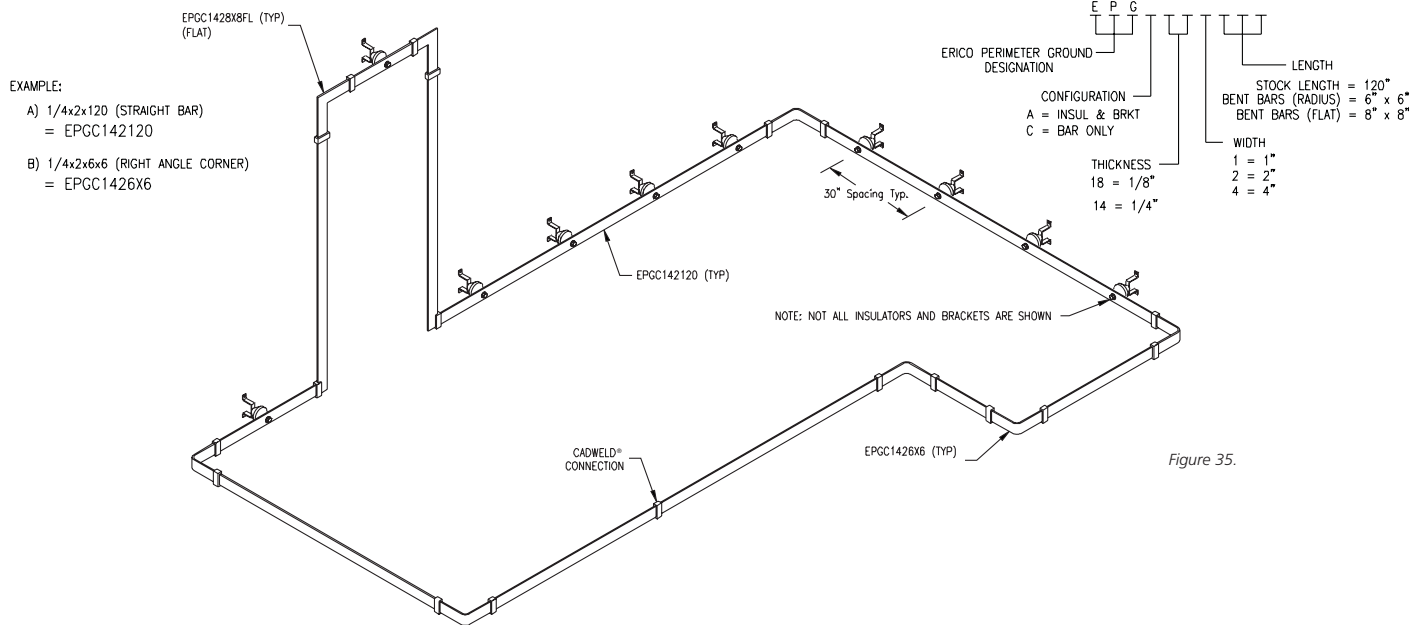
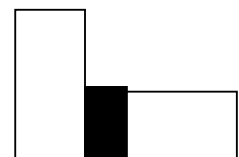
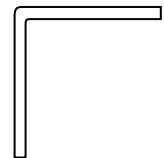
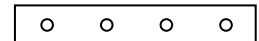

Figure 35.

Perimeter Bus

Part No.	T (in)	W (in)	L (in)	Description
Straight Bus				
EPGC181120	1/8	1	120	Perimeter Ground Bus, with 7/16" Holes on 30" Centers
EPGC182120	1/8	2	120	Perimeter Ground Bus, with 7/16" Holes on 30" Centers
EPGC184120	1/8	4	120	Perimeter Ground Bus, with 7/16" Holes on 30" Centers
EPGC141120	1/4	1	120	Perimeter Ground Bus, with 7/16" Holes on 30" Centers
EPGC142120	1/4	2	120	Perimeter Ground Bus, with 7/16" Holes on 30" Centers
EPGC144120	1/4	4	120	Perimeter Ground Bus, with 7/16" Holes on 30" Centers
90 degree Angle for Walls				
EPGC1816X6	1/8	1	6X6	90 degree angle for around walls
EPGC1826X6	1/8	2	6X6	90 degree angle for around walls
EPGC1846X6	1/8	4	6X6	90 degree angle for around walls
EPGC1416X6	1/4	1	6X6	90 degree angle for around walls
EPGC1426X6	1/4	2	6X6	90 degree angle for around walls
EPGC1446X6	1/4	4	6X6	90 degree angle for around walls
Flat 90 degree Angle for Doors				
EPGC1818X8FL	1/8	1	8X8	Flat 90 degree angle for around doorways
EPGC1828X8FL	1/8	2	8X8	Flat 90 degree angle for around doorways
EPGC1848X8FL	1/8	4	8X8	Flat 90 degree angle for around doorways
EPGC1418X8FL	1/4	1	8X8	Flat 90 degree angle for around doorways
EPGC1428X8FL	1/4	2	8X8	Flat 90 degree angle for around doorways
EPGC1448X8FL	1/4	4	8X8	Flat 90 degree angle for around doorways



Equipotential Bonding

Equipment Ground Plates

ERITECH® Cast Ground Plates

- Convenient ground system connection points in concrete structures
- Used for equipment, machinery and structure grounding
- Made from a copper alloy
- Result in current carrying capacity equal to that of the conductor or stud
- Will not loosen or corrode

B161-2Q With 4/0 Stud

B161-3Q With 500 kcmil Stud

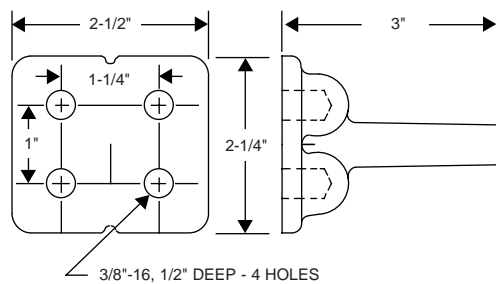

B164-2Q With 4/0 Stud

B164-3Q With 500 kcmil Stud

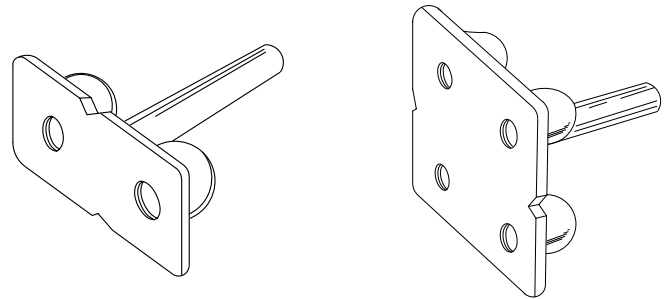
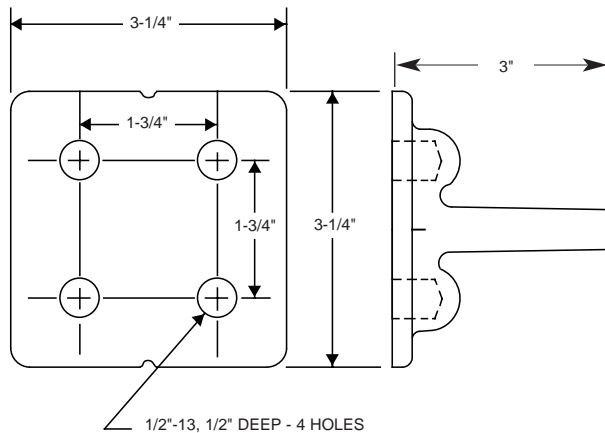

B162-2Q With 4/0 Stud

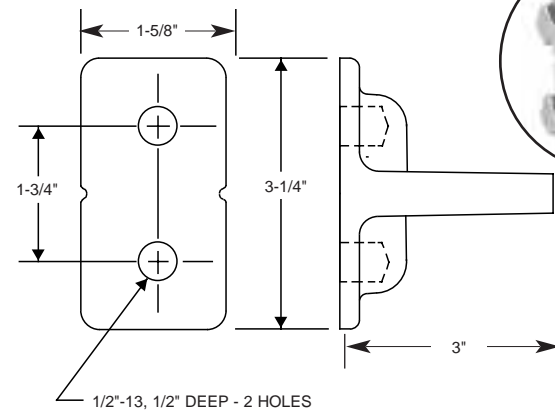

CAUTION: Use only ERITECH cast ground plates. Other similar plates may be available which do not meet the strength requirements necessary. They may crack or break during installation.

Use a CADWELD® Type TA or Type SS mold when connecting the ERITECH cast ground plate to the ground conductor. The cast ground plate stud size noted above fits the mold opening for a cable of the same size. Reference CADWELD catalog A1A for more information.

Example: Tee connection of 250 cable to B164-2Q (4/0 stud size), use mold TAC-2V2Q.

Splice connection of 250 cable to B164-2Q, use mold SSC-2Q2V.

ERITECH Clamp Style Ground Plate

- Cast bronze grounding plate
- Dimensions similar to B164 Series
- Cable connection under bolt tension

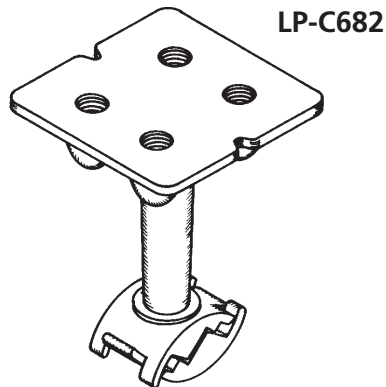

Equipotential Bonding

Equipment Ground Plates

ERITECH® Ground Plate Assemblies

Part No.	Style RA	Style RB	Style SS	Style TA
B1612Q	B530A"XL"	B531A"XL"	B532A"XL"	B533A"XL"
B1613Q	B530B"XL"	B531B"XL"	B532B"XL"	B533B"XL"
B1622Q	B530C"XL"	B531C"XL"	B532C"XL"	B533C"XL"
B1642Q	B530D"XL"	B531D"XL"	B532D"XL"	B533D"XL"
B1643Q	B530E"XL"	B531E"XL"	B532E"XL"	B533E"XL"

NOTE:	X (CONDUCTOR CODE)*	EXAMPLE:
Add appropriate suffix:	#4 = 1L 4/0 = 2Q	B164-2Q Ground Plate
For "XL":	#2 = 1V 250 = 2V 4/0 Pigtail 4 feet long	
X = Conductor Code	1/0 = 2C 350 = 3D	RA Style B530D2Q48
L = Length in inches	2/0 = 2G 500 = 3Q	

*Conductor codes are for concentric strand copper cable.

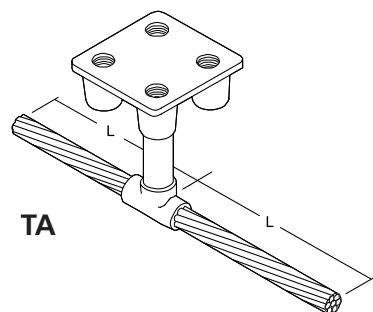
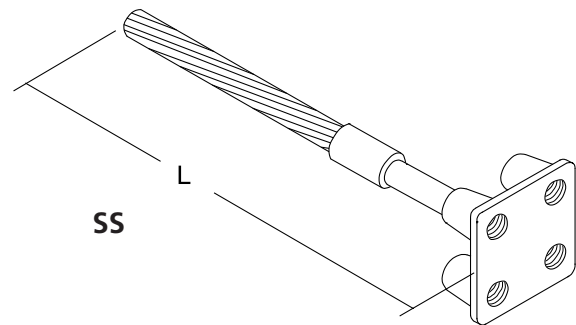
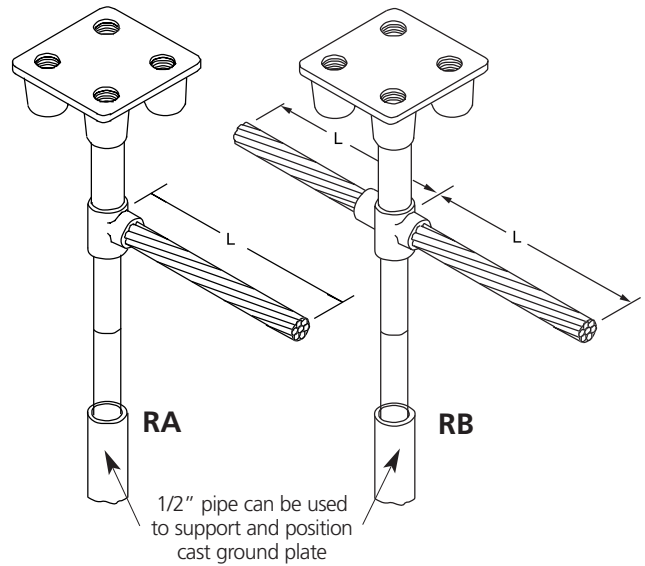

Equipotential Bonding

Aircraft Receptacles

ERITECH® Aircraft Grounding Receptacles for CADWELD® Process

- Copper alloy castings for use in static grounding systems of aircraft refueling areas
- Easily connected to grounding system conductor and/or ground rods
- Designed for simple installation with flush paved surfaces
- 3/4" cast ball, 3/4" removable ball, 3/4" cast bar or 1-1/2" bar attachment points available

B165	Depth A, from grade to level of support Diameter C at grade level Attachment Point	4-1/2" 2-3/4" Cast 3/4" ball
B165R	Depth A, from grade to level of support Diameter C at grade level Attachment Point	4-1/2" 2-3/4" Removable 3/4" ball
B166	Depth A, from grade to level of support Diameter B, maximum ring size Diameter C at grade level Attachment Bar	6-1/4" 4-3/4" 3-7/8" 3/4" diameter
B167	Depth A, from grade to level of support Diameter B, maximum ring size Diameter C at grade level Attachment Bar	7-1/4" 6-1/2" 4-3/4" 1-1/2" diameter
Notes:	1. Aircraft static grounding clamp B2617A can be used to connect to the B165, B165R and B166. 2. See Catalog A1A for CADWELD connections to aircraft grounding receptacles.	

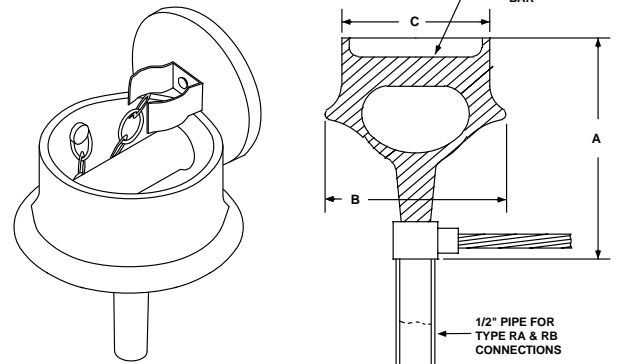
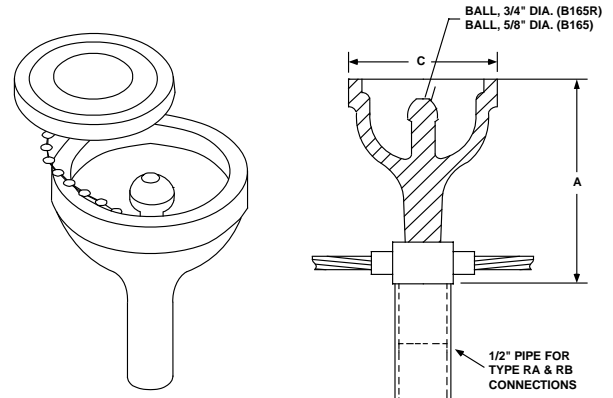

ERITECH Aircraft Grounding Receptacles for Sectional Ground Rods

LPC680

- Cast bronze aircraft receptacle
- Standard pin connection
- Chain retained cover plate
- Couple directly to 3/4" sectional rod or 3/4" extension rod
- Install flush with finish floor surface

LPC681

- Cast bronze aircraft receptacle
- Standard pin connection
- Chain retained cover plate
- Spring clip to secure cover plate
- Couple directly to 3/4" sectional rod or 3/4" extension rod
- Install flush with finish floor surface

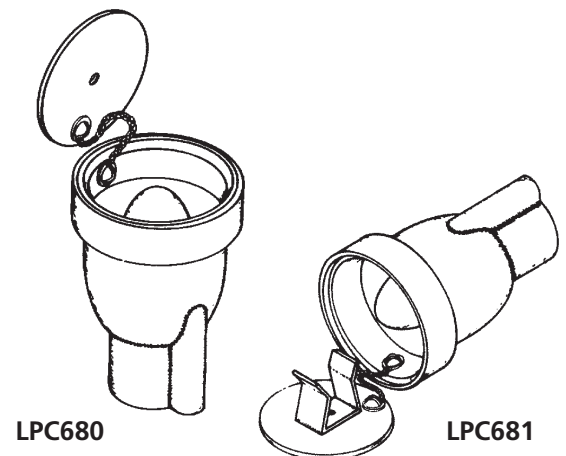

Equipotential Bonding

Transient Earth Clamp/Joint Protector

Transient Earth Clamp

The Transient Earth Clamp (TEC) acts to bond the separate ground points into an equipotential system, should the differential voltage between these two points exceed the TEC firing voltage.

Part# TEC100C

- Automatic reset after operation
- Robust housing for extended outdoor use
- 100kA 8/20 μ s surge rating
- Simple to install
- 350V "breakdown" voltage



Figure 36. CRITEC® Transient Earth Clamp.

Insulated Joint Protector

ERICO's Insulated Joint Protector (IJP) is designed to protect insulated joints in oil/gas pipelines by providing open circuit under "normal operations" but equipotential bonding under transient conditions with an automatic "re-set".

Part# IJP230 (230V)
IJP350 (330V)

- Automatic reset after operation
- Robust housing for extended outdoor use
- 100kA 8/20 μ s surge rating
- Simple to install
- 350V or 230V "breakdown" voltage



Figure 37. CRITEC Insulated Joint Protector

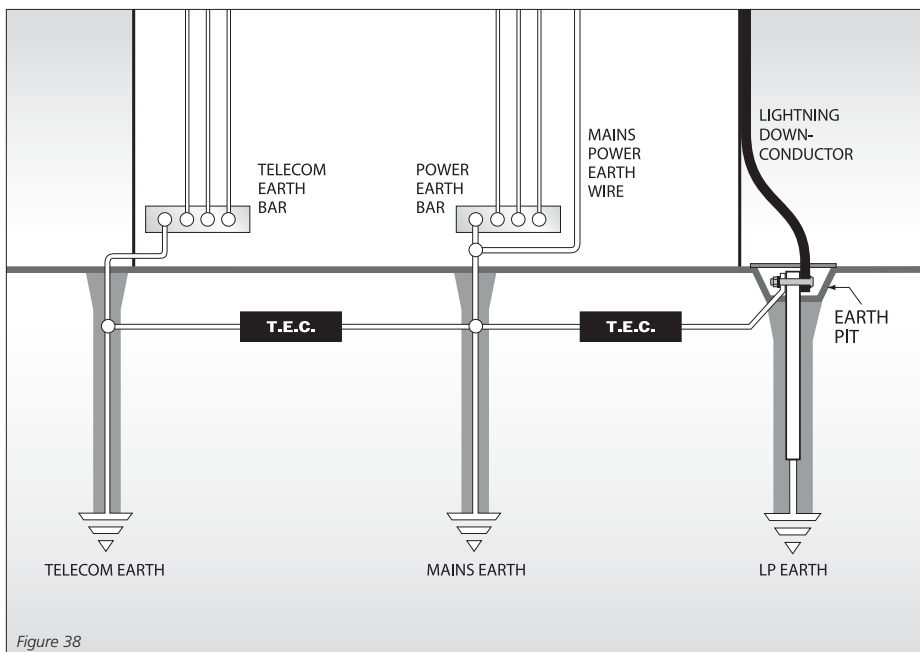

Figure 38

Figure 38. Diagram shows separate building ground systems bonded together with Transient Earth Clamps. This provides protection in the event of a lightning induced surge.



Equipotential Bonding

Signal Reference Grid (SRG)

Signal Reference Grid (SRG)

The Signal Reference Grid (SRG) is a pre-fabricated low impedance network of conductors established to create an equipotential plane for high frequency, low voltage digital signals in such applications as intensive computer, telemetry and telecommunications installations.

Digital signal line voltages are typically low. Their sensitivity to transient noise is very high (typically 1 volt for some digital systems). The SRG complies with IEEE Standard 1100-1992 for grounding practices in sensitive electronic environments.

Proper grounding and bonding of sensitive electronic systems, including computer installations, requires careful consideration of all frequencies from DC to over 100 megahertz. The local requirements for electrical fault current and lightning protection must also be met.

The safety grounding system required by Code does not address the special requirements of noise immunity. An additional "grounding" system called the Signal Reference Grid (SRG) is needed to assure trouble-free equipment performance.

(See Technical Section on page 73)

The importance of SRGs for Computer Applications

In order to minimize the effects of noise, many computer manufacturers, users and government agencies have detailed specifications regarding computer grounding. Computer installations are particularly sensitive to:

- Coupling between adjacent power, data circuits and ground, where noise can be introduced into cables – even nearby lightning strikes can be a real threat
- Noise levels from nearby transmitters may be a serious problem and require shielding

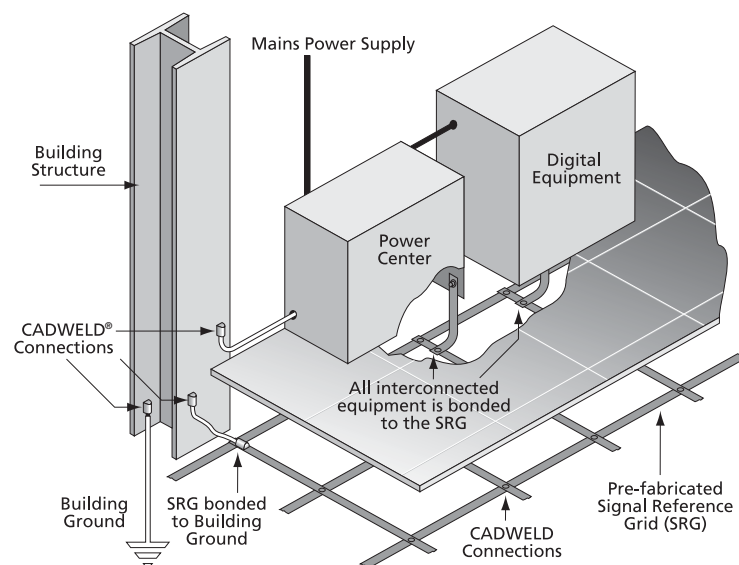

Figure 39. Signal Reference Grid with bonded connections to main building ground.

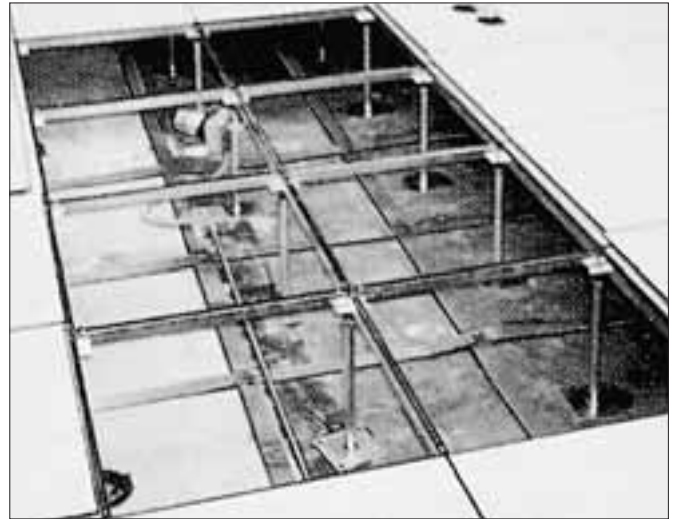

Figure 40. Pre-fabricated Signal reference Grid installed under computer room floor.

Components of the SRG

An effective SRG:

- Uses a multitude of conductors to create a very low impedance to noise at any frequency
- Typically uses two foot spacing between conductors
- Uses terminations that provide a constant impedance over the life of the facility
- Uses multiple paths within the SRG to allow the noise currents to divide at each crossover, which further reduces voltage drop
- Uses a mesh made of flat copper strips to provide the most functional low impedance and cost effective computer grounding system available.
- Uses welded connections to assure a noise-free bond

Welded Connections

Welded connections are often specified because they are the only connections proven to assure a "noise-free" bond. Normal shock and vibration jar mechanical connections, creating electronic noise. This causes relatively high Ldi/dt voltages due to a sudden change in connection impedance. This sudden change can result in pulses which can be coupled onto the signal circuits. These unwanted signals can create false data or even cause permanent circuit damage. Corrosion, dirt and cleaning fluids cannot interfere with the molecular bond of a welded joint.

Equipotential Bonding

Signal Reference Grid (SRG)

Signal Reference Grid Installation

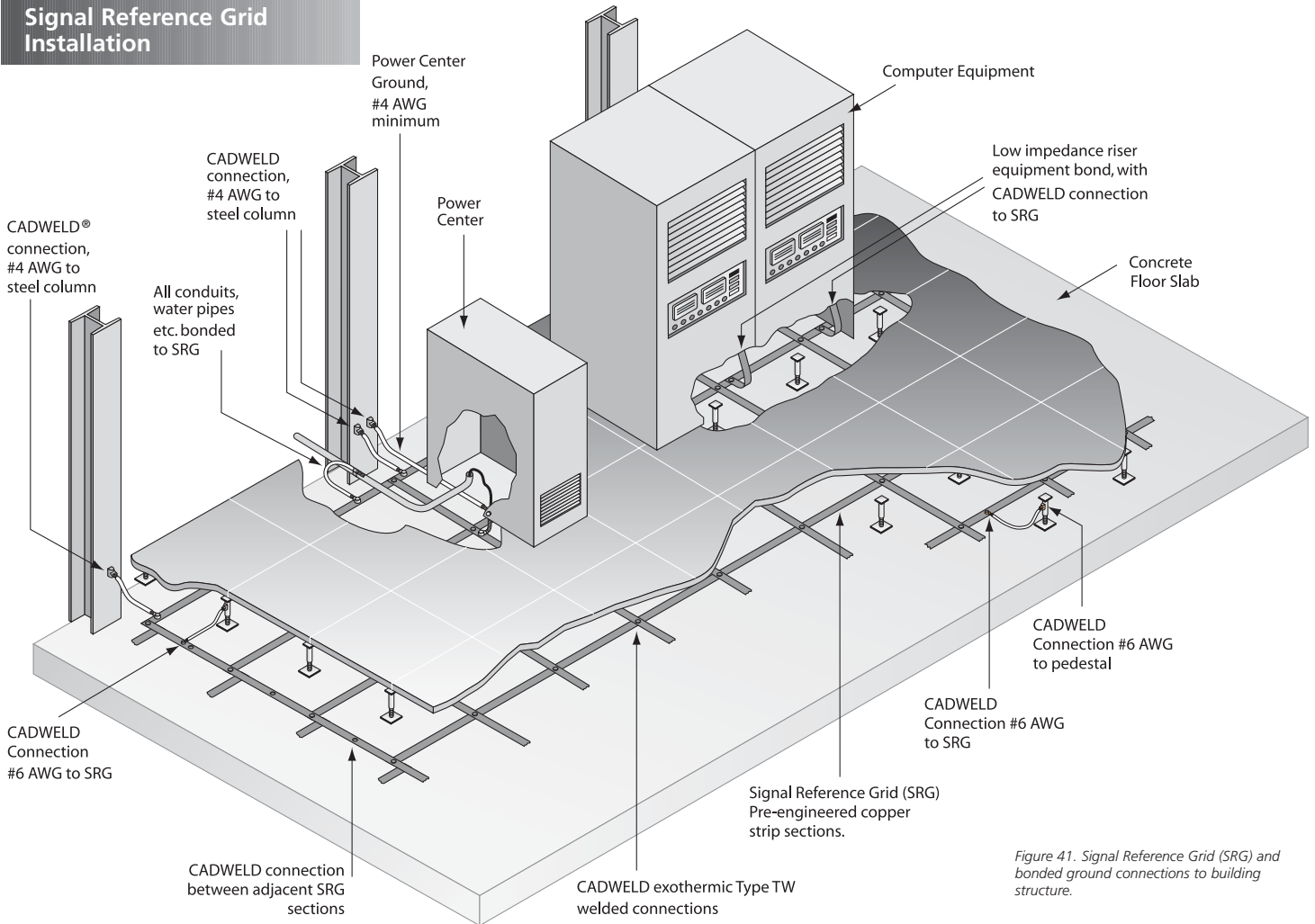

Figure 41. Signal Reference Grid (SRG) and bonded ground connections to building structure.

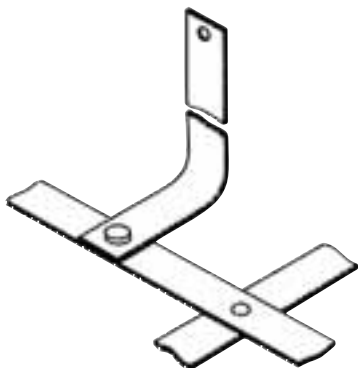

Figure 42. Low Impedance Riser (LIR), is welded to the SRG using the Type TW mold. For details, see page 49.

Installation

Important points to consider when installing an SRG:

- Local codes must be followed.
- All equipment shall be bonded to the ERICO SRG using low impedance risers. Never connect to strip closest to outside wall.
- All raised floors within the computer room should be bolted stringer type.
- Every 6th raised floor pedestal in each direction shall be connected to the SRG using a #6 AWG concentric copper conductor. The connection to both the pedestal and the SRG shall be CADWELD.
- All columns, conduits, water pipes, ducts, etc. entering the computer room shall be bonded to the SRG (at each end of the room if these are horizontal).
- Power distribution panels and power distribution center should be mounted directly to the building steel or bonded to it by a short length of grounding conductor equal to the "green wire ground" but at least #4 AWG copper. The grounding wire inside any panel or enclosure supplying AC power to the computer must be bonded to its enclosure.



Equipotential Bonding

Signal Reference Grid (SRG)

How to Specify

The Signal Reference Grid shall be manufactured from 2 inch wide by 26 gauge (0.0159 inch thick) copper strips on 2 foot, 600mm or 1200mm centers. All crossovers shall be joined by welding. The SRG shall be furnished 4 to 16 feet wide. The sections shall be rolled on tubes with the outside of the roll protected for shipment. These sections shall be bonded to each other in the field with CADWELD® connections.

Note:

1. Other strip sizes are available
2. Other spacing is available
3. Roll weight usually limited to about 200 pounds gross weight for convenience (1200 sq. ft.)

Figure 43. The pre-fabricated Signal Reference Grid sections are constructed with factory-made connections and then each section is connected on site with type TW field made connections.

Factory Made connection

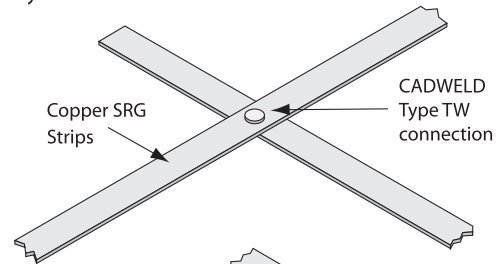

Type TW Field-made connection

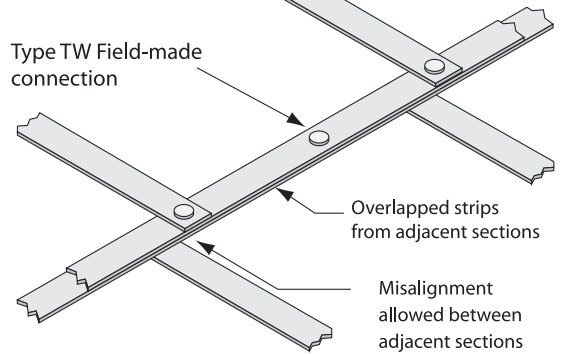

Signal Reference Grid Rolls

Part No.	Width (ft)	Length (ft)	Grid Spacing
SRGBC120	8	120	2' x 2'
SRGBD100	10	100	2' x 2'
SRGBE100	12	100	2' x 2'
SRGBF100	14	100	2' x 2'
SRGBG100	16	100	2' x 2'

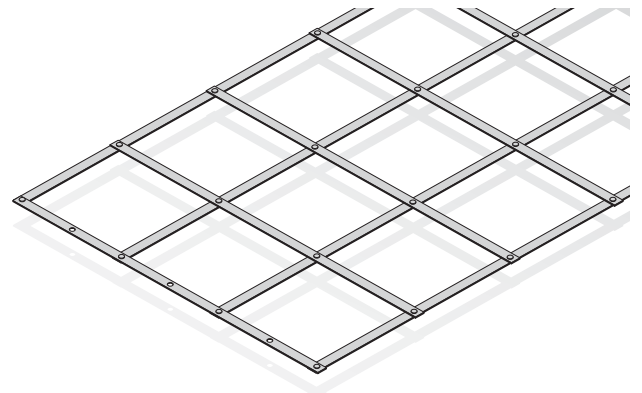

CADWELD Type TW connections			
Mold Style	Mold Part No.	Weld Metal	Handle Clamp
EXOLON	XLTWR107A3	XL32	XLL160
STANDARD	TWR107A3	32	L160

How to Order

Signal Reference Grids are custom-made to suit your needs. Each Grid is comprised on CADWELD Type TW connections, Pedestal connections and SRG support clip.



Equipotential Bonding

Signal Reference Grid (SRG)

CADWELD® Standard Connections to Steel Pedestal

Conductor Size	Pedestal Type	CADWELD Mold Part No.	Weld Metal	Handle Frame
#6 AWG-7 strand	1" round	VTP1H005M	#15	B399CS
#6 AWG-7 strand	7/8" square	VGT1H004M	#15	B399AS
#4 AWG-7 strand	1" round	VTP1L003M	#15	B399CS
#4 AWG-7 strand	7/8" square	VGT1L010M	#15	B399AS
#2 AWG-7 strand	1" round	VTP1V004M	#15	B399CS
#2 AWG-7 strand	7/8" square	VGT1V004M	#15	B399AS

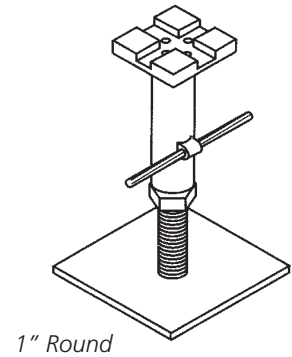

1" Round

CADWELD® EXOLON Low Emission Welding Process Connections¹

Conductor Size	Pedestal Type	CADWELD Mold Part No.	Weld Metal	Handle Frame
#6 AWG-7 strand	1" round	XLVTP1H005M	XL15XL	B399CS
#6 AWG-7 strand	7/8" square	XLVGP1H004M	XL15	XLB399BS
#4 AWG-7 strand	1" round	XLVTP1L003M	XL15	XLB399CS
#4 AWG-7 strand	7/8" square	XLVGP1L010M	XL15	XLB399BS
#2 AWG-7 strand	1" round	XLVTP1V004M	XL15	XLB399CS
#2 AWG-7 strand	7/8" square	XLVGP1V004M	XL15	XLB399BS

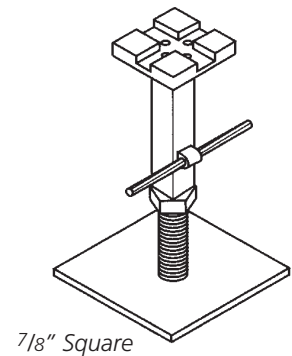

7/8" Square

¹See EXOLON Note below

SRG Support Clip

When retrofitting an existing computer room, the SRG can be supported above the power and data cables with the ERICO® SRG Support Clip.

Part No. B818A01 to fit both 1" round and 7/8" square raised floor pedestal.

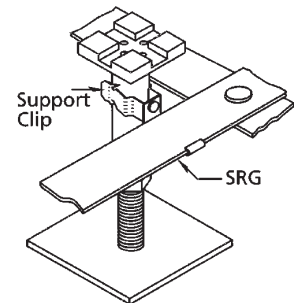
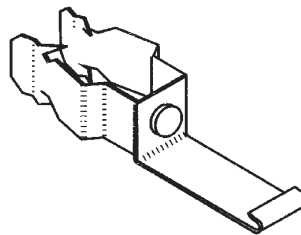

ERITECH® Low Impedance Riser (LIR)

- 26 gauge x 2" x 72" copper strip with 5/16" hole in one end for connecting to equipment (same material as used in the SRG)
- The LIR is welded to the SRG using the Type TW mold listed in chart above
- 40, 481 circular mils
- 23 ohms impedance for 12" length at 20 MHz
- Part No. B802D01A72

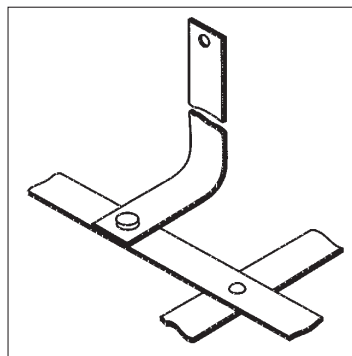

CADWELD EXOLON NOTE:

CADWELD EXOLON is a low emission welding process.

Required to start the CADWELD EXOLON reaction is the battery pack XLB971A1.

Welding Tray XLB974B2 can be used under the mold to protect cables and equipment from hot materials.

It is very useful on retrofit jobs.



Equipotential Bonding

Signal Reference Grids & Grounding

Other CADWELD® Connections for Computer Room Grounding

Bonding Conductor to 26 Gauge X 2" SRG

Conductor Size	Mold Style	Mold Part No.	Weld Metal	Handle Clamp
#6-7 Strand	CADWELD® EXOLON ¹	XLHAC1H013	XL25	XLL160
	STANDARD	HAC1H013	25	L160
#4-7 Strand	CADWELD EXOLON ¹	XLHAC1L020	XL32	XLL160
	STANDARD	HAC1L020	32	L160
#2-7 Strand	CADWELD EXOLON ¹	XLHAC1V012	XL32	XLL160
	STANDARD	HAC1V012	32	L160

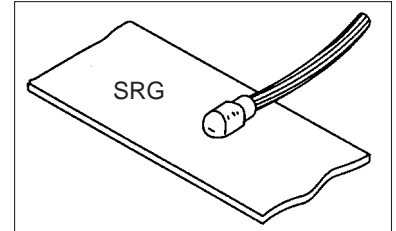

¹See CADWELD EXOLON Note, Page 46

CADWELD Type LA Lug

Conductor Size	Lug Part No. ¹	Mold Style	Mold Part No. ²	Weld Metal
#6-7 Strand	B101AA	CADWELD EXOLON ⁴	XLLAP1HAA ³	XL25
		STANDARD	LAT1HAA ³	25
#4-7 Strand	B101AA	CADWELD EXOLON ⁴	XLLAP1LAA	XL25
		STANDARD	LAT1LAA	25
#2-7 Strand	B101AA	CADWELD EXOLON ⁴	XLLAP1VAA	XL32
		STANDARD	LAT1VAA	32

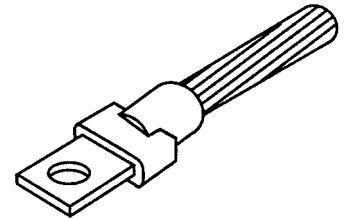

¹1/16 x 1/8 Copper lug with one hole for 1/4" screw

²Includes Handle Clamp

³Requires Sleeve B112

⁴See CADWELD EXOLON Note, Page 46

CADWELD Type VS to Steel Structure

Conductor Size	Mold Style	Mold Part No.	Weld Metal	Handle Clamp
#6-7 Strand	CADWELD EXOLON ²	XLVSP1H ¹	XL25	Included
	STANDARD	VST1H ¹	25	Included
#4-7 Strand	CADWELD EXOLON ²	XLVSC1L	XL45	XLL160
	STANDARD	VSC1L	45	L160
#2-7 Strand	CADWELD EXOLON ²	XLVSC1V	XL45	XLL160
	STANDARD	VSC1V	45	L160

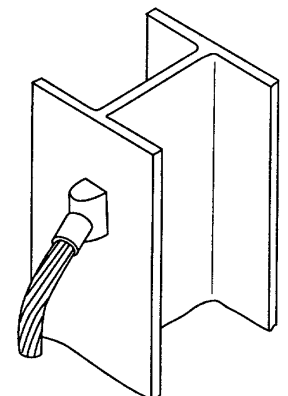

¹Requires Sleeve B112

²See CADWELD EXOLON Note, Page 46

Equipotential Bonding

Equipotential Mesh / Mats

Prefabricated Wire Mesh

ERICO® prefabricated wire mesh is a convenient, efficient and economical means of improving grounding systems at facilities with high-voltage installations and wherever large area grounds are required. Equipotential mesh reduces step potentials at power plants and substations and effectively minimizes ground plane fluctuations at communications antenna sites. Wire mesh is also an excellent ground screen, reflector and electronic shield for large facilities.

ERITECH® personnel safety mats, made of prefabricated wire mesh, are ideal for systems designed to protect operators against “touch potentials” at manually operated disconnect switches.

EQUIPOTENTIAL MESH FEATURES

- Silver brazed joints provide strength to resist separation during installation and bear the traffic of heavy vehicles
 - Furnished in rolls up to 20 feet wide
 - 500 pound maximum weight
 - Conductor spacing in many rectangular configurations up to 24" X 48" in 2" increments
 - Normally supplied in sections with standard overhang for interconnecting (1/2 conductor spacing + 2 inches)
- It can also be supplied with no overhang or other overhang configurations.
- See figures 46, 47 and 48 where M = conductor spacing, L = total length, W = total width

Wire Choices (Solid Wire)

- Pure copper (100% conductivity)
- Copper-clad steel (40% conductivity)
- Copper-clad steel (30% conductivity)

Available in Wire Sizes

#6 AWG, #8 AWG, #10 AWG and #12 AWG



Figure 44. Prefabricated wire mesh.

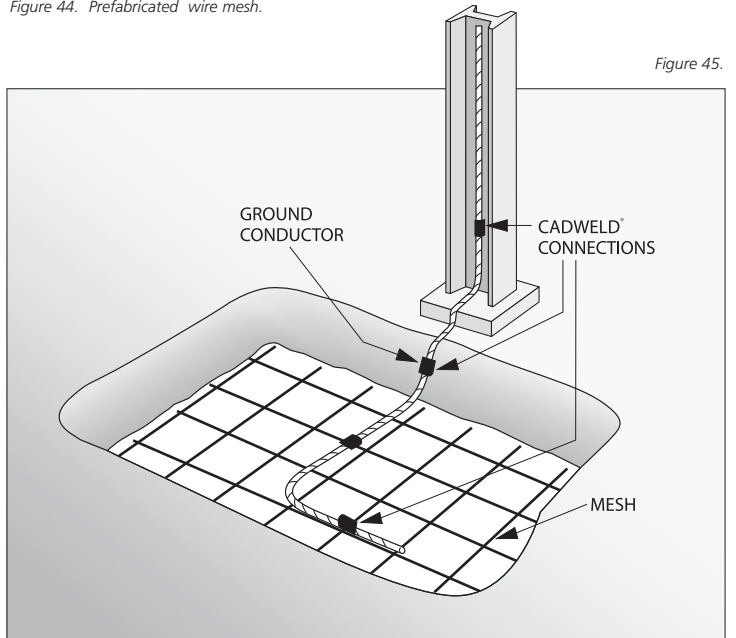

Figure 45.

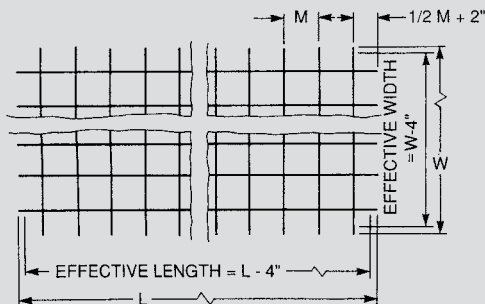

Figure 46. Standard overhang for interconnecting sections of mesh.

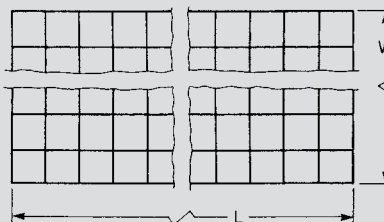

Figure 47. No overhang.

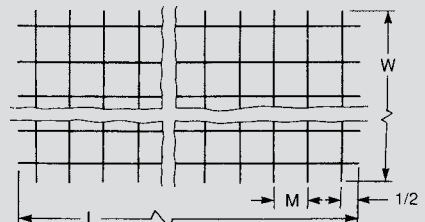

Figure 48. Half-spacing overhang.



Equipotential Bonding

Equipotential Mesh / Mats

Installation

Figure 49.

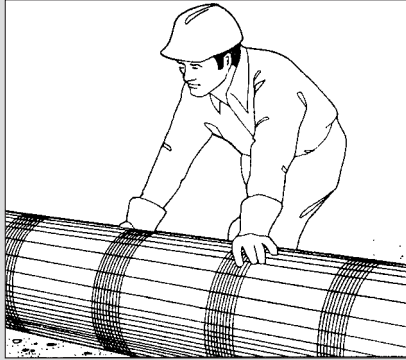

1. UNROLL MESH. No digging, trenching or special equipment required - the mesh is simply unrolled over the ground.

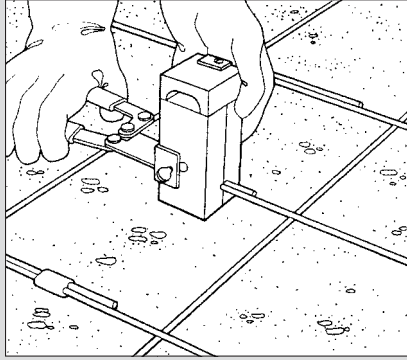

2. INTERCONNECT. Sections of mesh are interconnected using CADWELD® Type PG connections.

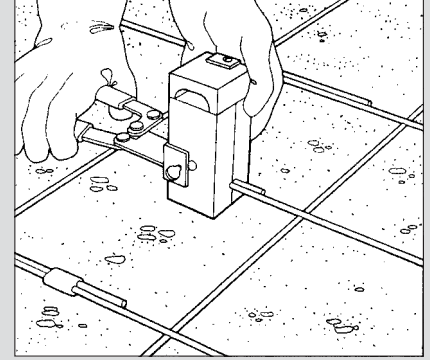

3. FINISHED JOB. Wire mesh cut and spliced to avoid contact with guy anchor. Wire mesh ready to be covered.

EASY TO INSTALL

- No digging or trenching required
- Unroll over the ground
- Interconnect by welding to adjacent sections of mesh using the CADWELD process
- Weld to the main ground grid in substations or welded to ground rods
- May be covered with a layer of earth or crushed stone depending on the application

INTERCONNECTING

- The CADWELD process provides a rapid and economical method of interconnecting mesh in the field
- Resulting weld is permanent and corrosion resistant
- Current carrying capacity equal to that of the conductor

NET WEIGHT (LBS) PER 1000 SQUARE FEET

Conductor Spacing (Inches)	Wire Size					
	#6 CS	#6 CU	#8 CS	#8 CU	#10 CS	#10 CU
2 x 2	888	974	558	609	351	383
4 x 4	443	487	279	305	175	192
6 x 6	295	325	186	203	117	128
8 x 8	222	243	139	153	88	96
12 x 12	148	163	93	102	59	64
24 x 24	74	91	47	51	29	32
48 x 24	56	62	35	38	23	24

NOTES: CS = Copper-clad Wire CU = Solid Copper Wire
Add 75 pounds per roll for approximate shipping weight.

SUGGESTED SPECIFICATIONS

Prefabricated Wire Mesh shall be manufactured using (a)* AWG bare, solid (b)* wire on a (c)* inch x (c)* inch conductor spacing with all cross connections silver brazed using a 35% silver alloy brazing material and a non-corrosive flux. It shall be (d)* feet, (d)* inches wide by (e)* feet, (e)* inches long with (f)* inches overhang on both sides and both ends, and shall be wound on a fiber tube with the outside of the roll protected by wood strips interconnected with steel wire.

- * (a) Wire size, #6, #8, #10, or #12 AWG.
- (b) 30% or 40% conductivity copper-clad or pure copper.
- (c) 2 inches x 2 inches minimum to 48 inches x 24 inches maximum (in 2 inch increments).
- (d) 20 feet, 4 inches maximum.
- (e) Maximum length determined by weight, with a 500 pound maximum net weight.
- (f) No overhang, an overhang equal to one-half conductor spacing or an overhang equal to one-half conductor spacing plus 2 inches (for interconnecting). See Figures 46, 47 and 48 on page 48.

Equipotential Bonding

Equipotential Mesh / Mats

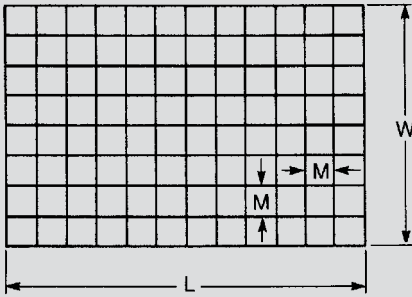

Figure 50. Standard safety mat.

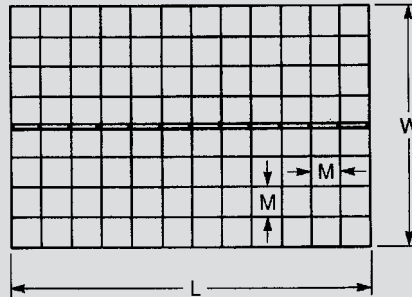

Figure 51. Safety mat with center wire.

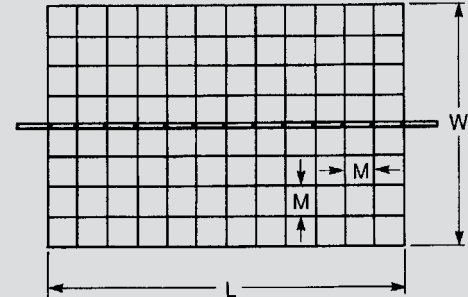

Figure 52. Safety mat with overhanging center wire.

MAT SIZES

4' X 4' 4' X 6' 4' X 6'
Contact ERICO® for other sizes

CONDUCTOR SPACING

2" X 2" to 12" X 12"
(in 2 inch increments)

CENTER WIRE OPTION

5/16 (approx. 1/0)
5/16 (approx. 1/0)
with or without 6" overhang

NET WEIGHT (LBS) EACH STANDARD MAT

	Conductor Spacing (Inches)									
	2 x 2		4 x 4		6 x 6		8 x 8		12 x 12	
	Standard Mat Size (square feet)									
Wire Size	4 x 4	4 x 6	4 x 4	4 x 6	4 x 4	4 x 6	4 x 4	4 x 6	4 x 4	4 x 6
#6	14.6	21.7	7.6	11.2	5.3	7.7	4.1	6.0	2.9	4.2
#8	9.2	13.7	4.8	7.1	3.3	4.9	2.6	3.8	1.9	2.7

NOTES: Weights are for copper-clad wire. Add 10% for approximate weight of solid copper wire. Safety mats are palletized for shipment. Add 50 pounds per pallet for gross weight. Maximum of 100 mats per pallet.

SUGGESTED SPECIFICATIONS

Standard Personnel Safety Mats:

Prefabricated personnel safety mats shall be manufactured using (a)* AWG bare, solid (b)* wire on (c)* inches x (c)* inches conductor spacing. All cross connections shall be silver brazed using a 35% silver brazing alloy and a non-corrosive flux. Overall mat size shall be (d)* feet x (d)* feet.

Mats With Center Wire:

Prefabricated personnel safety mats shall be manufactured using (a)* AWG bare, solid (b)* wire on (c)* inches x (c)* inches conductor spacing with (e)* diameter solid copper center wire through the (f)* length overhanging each end (g)* inches. All cross connections shall be silver brazed using a 35% silver brazing alloy and a non-corrosive flux. Overall mat size shall be (d)* feet x (d)* feet.

- * (a) #4, #6 or #8 AWG.
- (b) 30% or 40% conductivity copper-clad or pure copper (#4 available only in pure copper).
- (c) Minimum of 2 inches, maximum of 12 inches in 2 inch increments.
- (d) Standard sizes are 4 feet x 4 feet and 4 feet x 6 feet with maximum 6 feet x 8 feet.
- (e) 5/16 inch (1/0 solid) or 3/8 inch (2/0 solid). Stranded cable is also available.
- (f) Longest or shortest.
- (g) Center wire is either flush (0 inch overhang) or 6 inches overhang (see Figures 51 and 52). Other overhangs are also available.



Equipotential Bonding

Equipotential Mesh / Mats

Prefabricated Wire Mesh Signal Reference Grid Application

For applications of mesh used as signal reference grid (SRG) embedded in the concrete floor, a CADWELD® Cast Ground Plate is mounted flush with the finished floor and connected to the mesh. Future equipment is then connected to the ground plate.

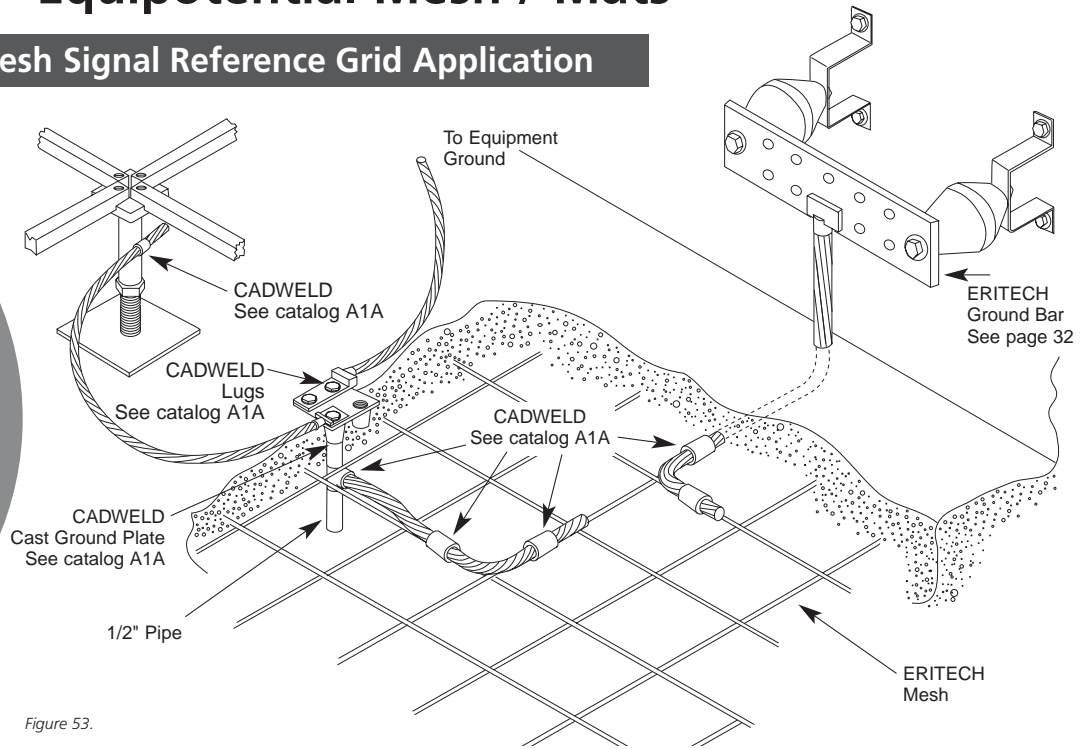

Figure 53.

ERITECH® Wire Mesh and Personnel Safety Mat Connections

Type PG - Joining Adjacent Sections of Wire Mesh

Solid Wire Sizes (AWG#)	Welder ¹	Weld Metal
6 Copper	PGT-06CU	#25
6 Copper-clad	PGT-06CS	15
8 Copper	PGT-08CU	15
8 Copper-clad	PGT-08CS	15
10 Copper	PGT-10CU	15
10 Copper-clad	PGT-10CS	15

¹Includes mold handles.

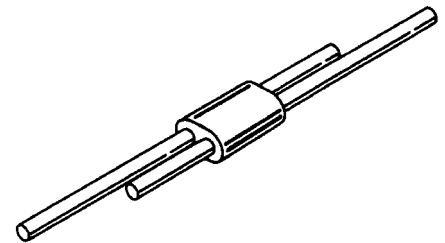

TYPE PG

Type PT - Cable to Wire Mesh or Safety Mat

Mat Wire	Cable	Mold ²	Weld Metal
#6 Solid	1/0	PTC-1G2C	#65
	2/0	PTC-1G2G	65
	4/0	PTC-1G2Q	90
#8 Solid	1/0	PTC-1D2C	65
	2/0	PTC-1D2G	65
	4/0	PTC-1D2Q	90
#10 Solid	1/0	PTC-1A2C	65
	2/0	PTC-1A2G	65
	4/0	PTC-1A2Q	90

²Molds require L-160 handle clamps - order separately

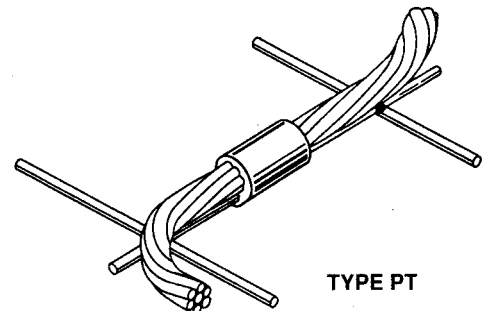

TYPE PT

Equipotential Bonding

Equipotential Mesh / Mats

Prefabricated Wire Mesh

Type SS and PT - Safety Mat Center-Wire Connections

Mat Pigtail Solid	Cable Size Stranded	Type SS		Type PT	
		Mold No. ¹	Weld Metal	Mold No.	Weld Metal
1/0	1/0	SSC-2C2B	#65	PTC-2B2C	#115
1/0	2/0	SSC-2G2B	65	PTC-2B2G	115
1/0	3/0	SSC-2L2B	90	PTC-2B2L	150
1/0	4/0	SSC-2Q2B	90	PTC-2B2Q	150

¹Molds require L-160 handle clamps - order separately

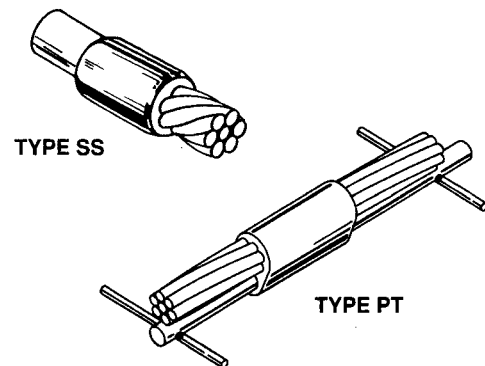

Equipotential Bonding

Temporary Protective Grounding Jumpers

ERITECH® Cable Connections to Clamps

Proper cable end preparation is of vital importance. The applied ends are called ferrules. There are two common preparation methods – both methods have limitations.

The soldered ferrules rely on a filler (solder) which melts at a low temperature. This, along with the forces associated with faults, could cause failure before the fault clears.

The crimp or compression ferrules, while somewhat better, rely on surface contacts. These are subject to damage from over-compression, loosening from under-compression, and corrosion, causing an increase in resistance.

CADWELD® offers a better alternative.

1. Some clamps require a plain solid stud. For these, a casting of CADWELD metal of the correct diameter is made directly to the flexible conductor end. The cable insulation is securely clamped for mechanical support (Figure 54).
2. Some clamps require a threaded stud. For this style, a threaded silicon bronze stud is welded to the conductor end with a CADWELD connection (Figure 55). These clamps do not provide a means of cable support. A heat shrink is therefore applied to the conductor over the insulation and CADWELD connection.

Plain Stud Style

Cable Size	Mold Part No.	Sleeve Part No.	Weld Metal	Stud Dia.
#2	PNC1W001	S429F1W12	#65	7/16"
1/0	PNC2E001	S429F2E	90	5/8"
2/0	PNC2J001	S429F2J	115	5/8"
4/0	PNC2S001	S429F2S	200	3/4"

Fixture B523 is recommended for all sizes listed. Clamp holds cable in position. Plate supports mold. Bolts to edge of bench. Heat shrink available in both A130C1 (black) and A130A3 (clear)

Threaded Stud Style

Cable Size	Stud Size	Stud Kit Part No.	Mold Part No.	Sleeve Part No.	Weld Metal
#2	1/2"-13	K-163*	SSC1W001	S429F1W12	#45
	5/8"-11	K-164*	SSC1W004	S429F1W12	65
1/0	1/2"-13	K-163*	SSC2E004	S429F2E16	65
	5/8"-11	K-164*	SSC2E007	S429F2E16	65
2/0	1/2"-13	K-163*	SSC2J004	S429F2J16	65
	5/8"-11	K-164*	SSC2J007	S429F2J16	65
4/0	1/2"-13	K-163*	SSC2S004	S429F2S16	90
	5/8"-11	K-164*	SSC2S005	S429F2S16	90

*Kit includes threaded silicon bronze stud, split lock washer and nut, plus black heat shrink tube. For kit with clear heat shrink, add suffix "C" to part number.

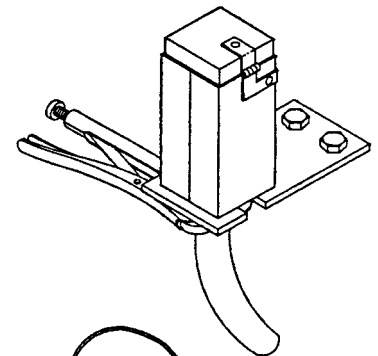

Figure 54

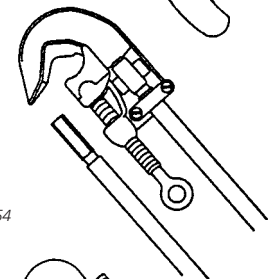

Figure 55

Ordering information:	
Mold	(average life of 50 connections)
Sleeve	(1 required per connection)
Weld Metal	(1 required per connection)
Heat Shrink	(1 required per connection)
L160 Handle Clamp	(includes flint ignitor)

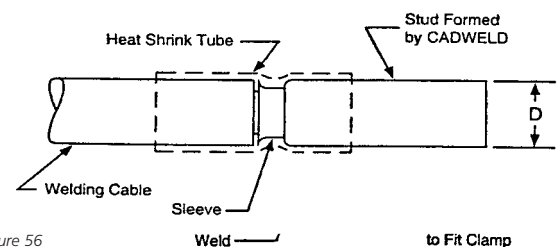

Figure 56

Equipotential Bonding

Bonding Devices

ERITECH® Prefabricated Lug bonds

Prefabricated lug bonds are custom made to specifications. Common usage includes cable tray bonding and grounding, structure bonds, surge arrester leads and power jumpers.

- Made with bare annealed copper cable
- Tinned copper lugs welded to the cable with CADWELD® connections

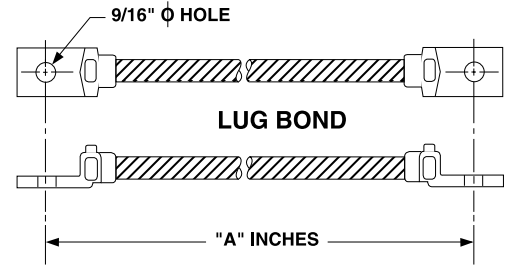

CABLE Size	Lug Str.	Lug Size (in.)	LUG BOND PART NO.*			
			One Hole	Two Hole	One Hole 45°	Two Hole 45°
4	7	1/8 x 1	B-212-1L-A	B-213-1L-A	B-214-1L-A	B-215-1L-A
2	7	1/8 x 1	B-212-1V-A	B-213-1V-A	B-214-1V-A	B-215-1V-A
1	7	1/8 x 1	B-212-1Y-A	B-213-1Y-A	B-214-1Y-A	B-215-1Y-A
1/0	7	1/8 x 1	B-212-2C-A	B-213-2C-A	B-214-2C-A	B-215-2C-A
2/0	7	1/8 x 1	B-212-2G-A	B-213-2G-A	B-214-2G-A	B-215-2G-A
4/0	7	3/16 x 1	B-212-2Q-A	B-213-2Q-A	B-214-2Q-A	B-215-2Q-A
250	19	3/16 x 1	B-212-2V-A	B-213-2V-A	B-214-2V-A	B-215-2V-A

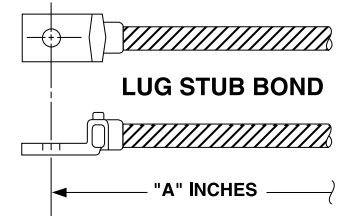

CABLE Size	Lug Str.	Lug Size (in.)	LUG BOND PART NO.*			
			One Hole	Two Hole	One Hole 45°	Two Hole 45°
4	7	1/8 x 1	B-216-1L-A	B-217-1L-A	B-218-1L-A	B-219-1L-A
2	7	1/8 x 1	B-216-1V-A	B-217-1V-A	B-218-1V-A	B-219-1V-A
1	7	1/8 x 1	B-216-1Y-A	B-217-1Y-A	B-218-1Y-A	B-219-1Y-A
1/0	7	1/8 x 1	B-216-2C-A	B-217-2C-A	B-218-2C-A	B-219-2C-A
2/0	7	1/8 x 1	B-216-2G-A	B-217-2G-A	B-218-2G-A	B-219-2G-A
4/0	7	3/16 x 1	B-216-2Q-A	B-217-2Q-A	B-218-2Q-A	B-219-2Q-A
250	19	3/16 x 1	B-216-2V-A	B-217-2V-A	B-218-2V-A	B-219-2V-A

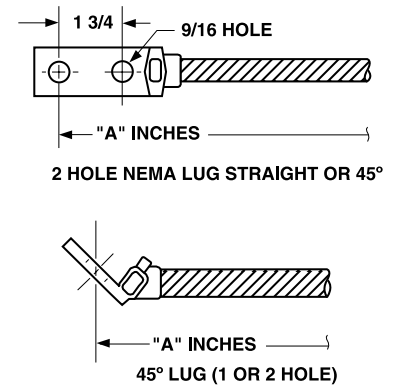

* "A" indicates bond length in inches

Equipotential Bonding

Bonding Devices

ERITECH® Bond Assemblies

Prefabricated cable to reinforcing bar bonding assemblies. Catalog numbered assembly includes 18" of #4 reinforcing bar with an exothermic weld to 5 ft. of copper cable. Wire tie or weld bar to construction steel before pouring concrete and route cable tail to down lead or ground lead location.

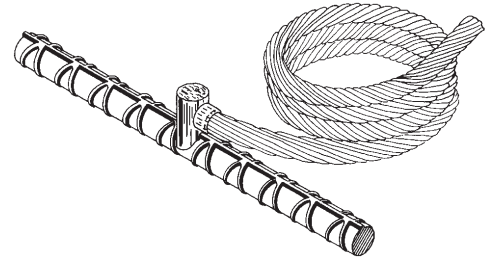

Part No.	Description
LP-P691	Bar with LP-C122 Copper Cable (For Class I Systems)
LP-P692	Bar with LP-C126 Copper Cable (For Class II Systems)
LP-P693	Bar with LP-C137 Copper Cable (4/0 conc)

ERITECH Arc Weldable Bonds

Flash welded (19 strand) concentric cable to steel rod for bonding connection to structural steel and to rebar. Arc weldable bonds are an economical alternative to exothermic welding when only a few connections need to be made and an arc welder is available on site. The rod is sized to match the ampacity of the cable for fault currents. Complete instructions are provided.



Part No.	Cable	Rod
EWB2G9164	2/0 x 4' long	.562" dia x 8" long
EWB2L584	3/0 x 4' long	.625" dia x 8" long
EWB2Q344	4/0 x 4' long	.750" dia x 8" long

All cable is 19 strand concentric

Welding To Rebar

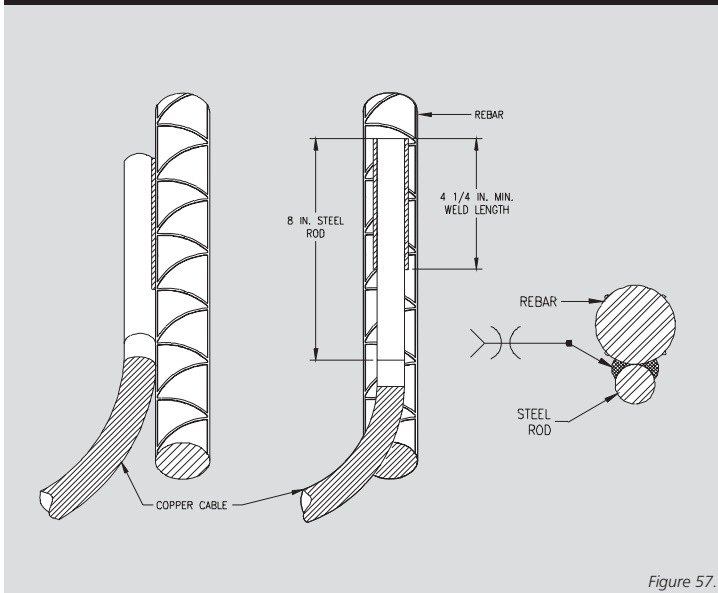

Figure 57.

Welding To Building Steel

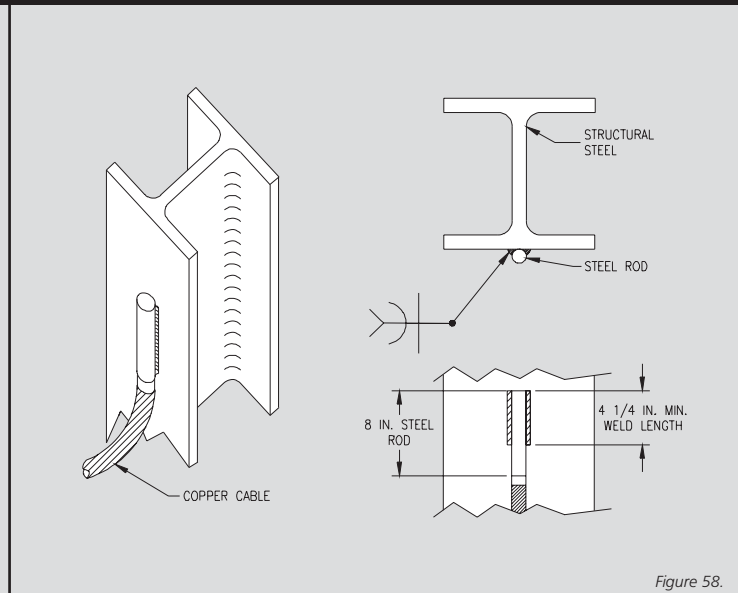

Figure 58.

Equipotential Bonding

Temporary Protective Grounding Jumpers

ERITECH® Copper Bonding Straps

Flexible Copper Bonding Straps with one lug hole at each end. Copper is tinned for bimetallic use. Extra flexible construction for use on hinged or sliding door bond and on vibrating machinery bond. Lug holes for 1/4" diameter bolt.

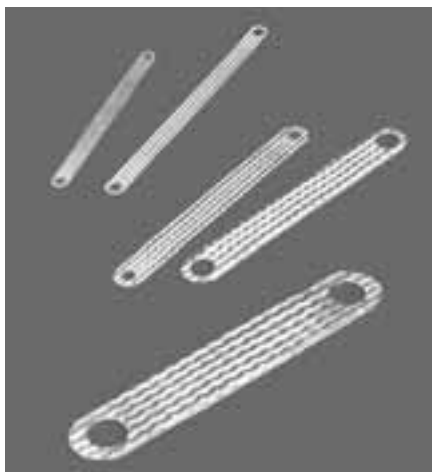

Description	Part Number	Ampacity A	Length Inches	Hole Size	Width Inches	Palm Length
MBJ 25-100-10	556670	150	4	3/8	1	1 1/4
MBJ 25-150-10	556680	150	6	3/8	1	1 1/4
MBJ 25-200-6	563340	150	8	1/4	1	1 1/4
MBJ 25-200-10	556690	150	8	3/8	1	1 1/4
MBJ 25-200-12	563430	150	8	1/2	1	1 1/4
MBJ 25-250-10	556700	150	10	3/8	1	1 1/4
MBJ 25-300-10	556710	150	12	3/8	1	1 1/4
MBJ 25-500-10	556950	150	20	3/8	1	1 1/4
MBJ 30-100-10	556720	180	4	3/8	1	1 1/4
MBJ 30-150-10	556730	180	6	3/8	1	1 1/4
MBJ 30-200-10	556740	180	8	3/8	1	1 1/4
MBJ 30-250-10	556750	180	10	3/8	1	1 1/4
MBJ 30-300-10	556760	180	12	3/8	1	1 1/4
MBJ 30-500-10	556960	180	20	3/8	1	1 1/4
MBJ 35-100-10	556770	197	4	3/8	1	1 1/4
MBJ 35-150-10	556780	197	6	3/8	1	1 1/4
MBJ 35-200-10	556790	197	8	3/8	1	1 1/4
MBJ 35-250-10	556800	197	10	3/8	1	1 1/4
MBJ 35-250-25	565000	197	10	1	1 1/2	2
MBJ 35-300-10	556810	197	12	3/8	1	1 1/4
MBJ 35-500-10	556970	197	20	3/8	1	1 1/4

Fence Post & Gate Grounding

ERITECH Flexible Jumpers - Factory Made

Flexible Jumpers are available in 2/0 and 4/0 AWG sizes.

Made from welding cable, both conductor flexibility and strand protection are provided. ERITECH Flexible Jumpers are used to bond gates, switch operating handles and any other item where movement or vibration requires a flexible grounding jumper.

The connections are made with CADWELD® exothermic connections using the same mold used for all your other fence post connections.

Conductor Size	Pedestal Type	Use Mold
2/0 AWG	FJ2Gxx	for 2/0 Concentric
4/0 AWG	FJ2Qxx	for 4/0 Concentric

xx is length in inches. 24" carried in stock.

Jumper or Conductor	Pipe Size	CADWELD Size Mold Part No	Weld Metal Size
2/0	*	VBC-2G-008-V*	#90
	1-1/4 to 3 1/2	VBC-2G-009	90
4/0	*	VBC-2Q-006-V*	115
	1-1/4 to 3 1/2	VBC-2Q-003	115

*Made to exact pipe size. Add nominal pipe size mold to part number.

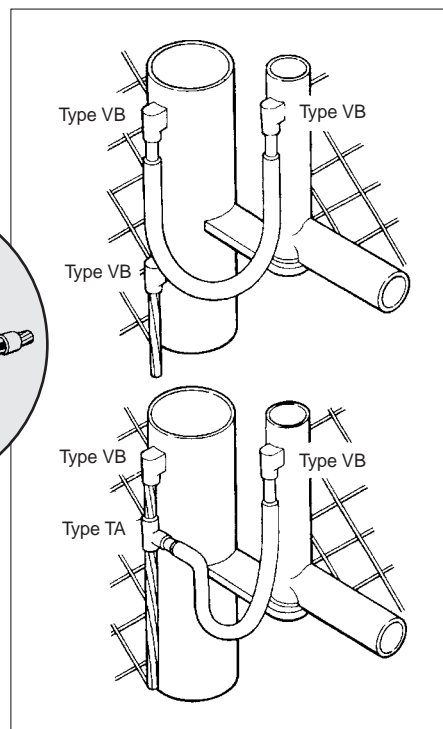
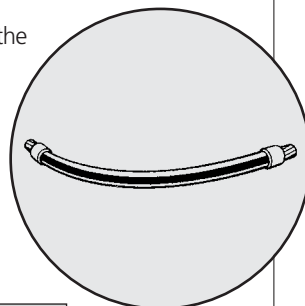

Equipotential Bonding

Fence Post & Gate Grounding

ERITECH® Flexible Jumpers - Field Made

Use your own inexpensive welding cable for grounding substation and other critical metal fence gates. The CADWELD® connection, giving you a permanent molecular bond, saves approximately 80% of the cost of braided cable and clamps. CADWELD connections can not loosen, are not subject to galvanic corrosion, and provide higher ampacity than the cable itself. Heat shrink tubing may be applied over the exposed ends.

How to order

1. Select welding cable size.
2. To base mold number, add appropriate data for round or square posts or frames.
3. Two corresponding sleeves are required for each welding cable jumper.
4. Two corresponding units of weld metal are required for each welding cable jumper.

Tooling

1. B-160-V combination E-Z Change Handle and Pipe Clamp fits pipe to 4 inches (ID).
2. B-158 extra chain is available in 20-inch lengths with one splice link.

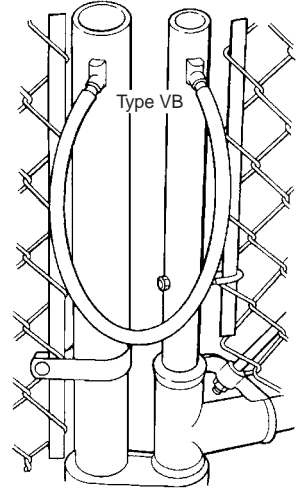

Gate Frame to Gate Post Bonds

Welding Cable (AWG#)	Mold Number Base Number	Sleeve Number	Weld Metal Size
4	VSC-1N*	S429F-1N12	45
2	VSC-1W*	S429F-1W12	45
1	VSC-2A*	S429F-2A12	65
1/0	VSC-2E*	S429F-2E16	90
2/0	VSC-2J*	S429F-2J16	90
3/0	VSC-2N*	S429F-2N16	115
4/0	VSC-2S*	S429F-2S16	115

* For round posts, add V followed by IPS size. Example: VSC-2E-V2.50.
For square posts, add VPS15 for 1.5", VPS20 for 2.0", VPS25 for 2.5", VPS30 for 3.0"**. Example: VSC-2E-VPS25.

**For "D" and "F" price key molds only.

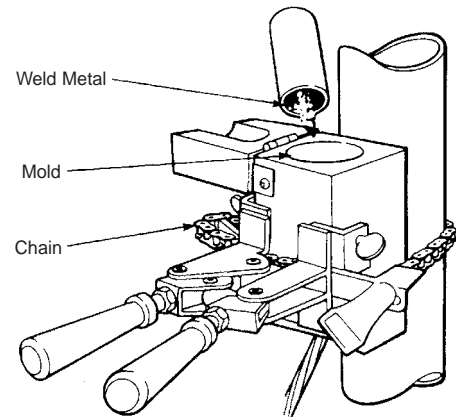

Equipotential Bonding

Fence Post & Gate Grounding

ERITECH® Clamps

When CADWELD® connections cannot be made to aluminum pipe or thin-wall steel tube, the CADWELD ground clamp solves your grounding problem.

- Made of tinned electrolytic copper
- Stainless-steel hardware
- Available for 1- to 4-inch nominal pipe sizes (Larger sizes on special order)
- Available for field welding or with factory-fabricated cable and/or flex leads

Factory-Fabricated Assemblies

Nominal Pipe Size	Single Lead Assembly ¹ Fig. 60	Double Lead Assembly ¹ Fig. 61*
1"	A235A- "XL"	A237A- "XL"
1-1/4"	A235B- "XL"	A237B- "XL"
1-1/2"	A235C- "XL"	A237C- "XL"
2"	A235D- "XL"	A237D- "XL"
2-1/2"	A235E- "XL"	A237E- "XL"
3"	A235F- "XL"	A237F- "XL"
3-1/2"	A235G- "XL"	A237G- "XL"
4"	A235H- "XL"	A237H- "XL"

¹Add "RH" or "LH" suffix to part number to indicate Right Hand or Left Hand
**XL" is code for cable size and length

Clamps Only - for Field-Welded Connections

Nominal Pipe Size	Clamp Part No. Fig. 59
1"	B522A
1-1/4"	B522B
1-1/2"	B522C
2"	B522D
2-1/2"	B522E
3"	B522F
3-1/2"	B522G
4"	B522H
5"	B522J
6"	B522K

Cable	Mold	W/M
1/0	LAC2C002	#65
2/0	LAC2G002	#65
4/0	LAC2Q002	#90

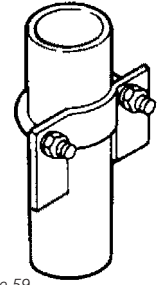

Figure 59.
Field-made Connections

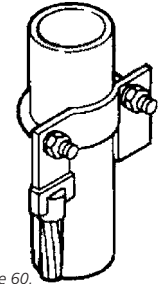

Figure 60.
With a Ground Lead
(Left Hand Shown)

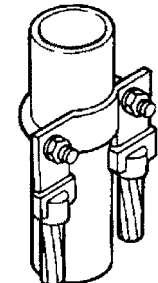

Figure 61.
With Two Ground Leads

Factory-Fabricated Assemblies

Gate Size Nominal	Post Frame Size Nominal	Gate Part No. ¹ Fig. 62	Assembly Part No. ¹ Fig. 63*
2-1/2"	1-1/4"	A238EB2S- "Y"	A239EB2S- "Y"- "XL"
	1-1/2"	A238EC2S- "Y"	A239EC2S- "Y"- "XL"
3"	1-1/4"	A238FB2S- "Y"	A239FB2S- "Y"- "XL"
	1-1/2"	A238FC2S- "Y"	A239FC2S- "Y"- "XL"
3-1/2"	1-1/4"	A238GB2S- "Y"	A239GB2S- "Y"- "XL"
	1-1/2"	A238GC2S- "Y"	A239GC2S- "Y"- "XL"
4"	1-1/4"	A238HB2S- "Y"	A239HB2S- "Y"- "XL"
	1-1/2"	A238HC2S- "Y"	A239HC2S- "Y"- "XL"

¹ Add "RH" or "LH" suffix to part number to indicate Right Hand or Left Hand
* "Y" is the length of the flexible cable jumper in inches.

All flexible cable sizes in the above listed part numbers are 4/0.

"XL" is the ground lead conductor size and length
"X" is the conductor size code as shown in the table.
"L" is the length in feet.

EXAMPLE: Figure 63. Assembly with a 4/0 24-inch flex and a 4/0 ground lead 4 feet long to a 3-1/2 inch gate post clamp, and a 1-1/2 inch gate frame clamp A239GC2S242Q4

"X" Conductor Coding	
Size	Code
1/0	2C
2/0	2G
4/0	2Q
7/#7	9C
7/#5	9E
19/#9	9F

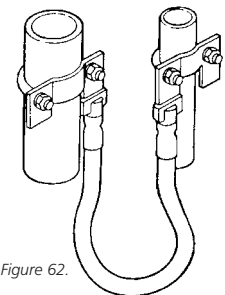

Figure 62.

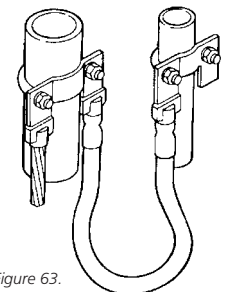

Figure 63.



Equipotential Bonding

Fence Post & Gate Grounding

Reference Data

Steel Pipe Sizes

Nominal	Standard Weight (Schedule 40)	
	O.D.	O.D.*
1"	1.315	1-5/16"
1-1/4"	1.660	1-5/8"
1-1/2"	1.900	1-7/8"
2"	2.375	2-3/8"
2-1/2"	2.875	2-7/8"
3"	3.500	3-1/2"
3-1/2"	4.000	4"
4"	4.500	4-1/2"

* To nearest fraction.

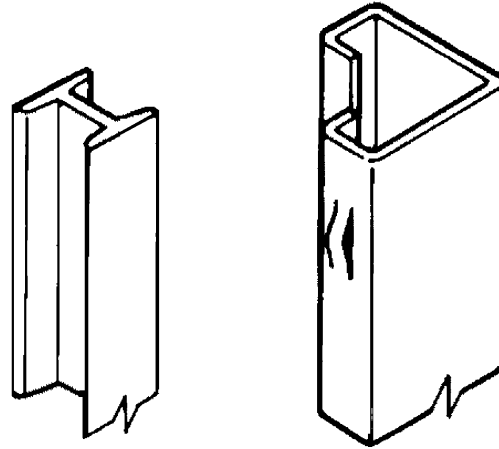

Other Standard Sections Used for Fence Posts

Section	CADWELD® Mold Code
1-1/2" Square	PS15
2" Square	PS20
2-1/2" Square	PS25
3" Square	PS30*
1.875 x 1.625 x 0.133 "H"	PH1
2.25 x 1.95 x 0.143 "H"	PH2

* For D or F Mold Price only.

Examples for CADWELD Molds:

1. A 4-inch outside-diameter pipe is a 3-1/2 inch nominal pipe size. The mold number for a 4/0 concentric conductor to this pipe would be:

VSC-2Q-V 3.50

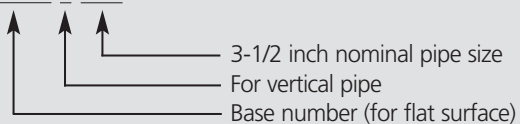

2. A nominal 2 x 2-1/4 inch H section uses mold code PH2. A 4/0 Type VB weld to this post would be VBC-2Q-PH2.

Static Grounding and Bonding

Static Grounding & Bonding Components

Conductors

A

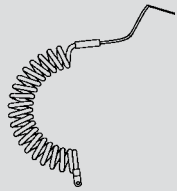

COILS

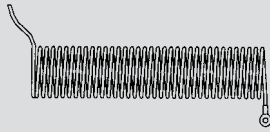

A822SB111C-20

A822SA111C-X

REELS

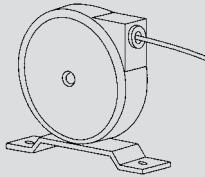

B2618A

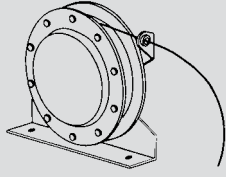

B2618B

CABLES

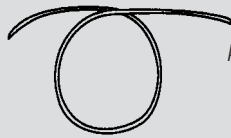

A805A01F-X

A806A3F-X

A822SAS-X

Conductor Terminations

B

GROUNDING CLAMPS

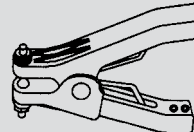

B2610A

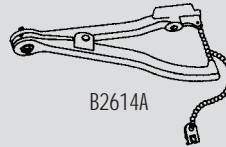

B2614A

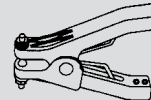

B2617A

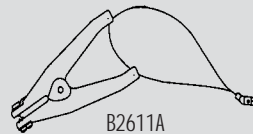

B2611A

"C" CLAMPS

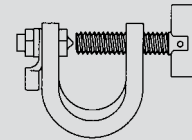

B2615B

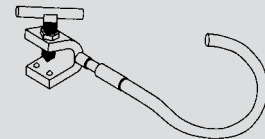

B2615C

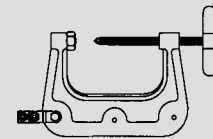

B2615A

Other Devices

DOOR & FRAME

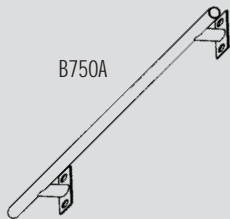

B750A

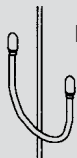

B570A

GROUND PLATES & TABS

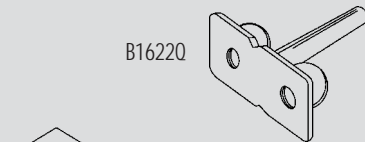

B1622Q

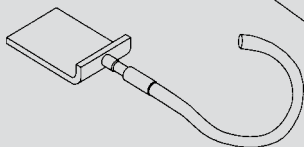

B2621A1

PIPE CLAMPS

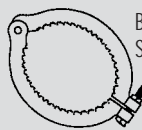

B2616A Series

CWPIJ

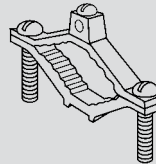

AIRCRAFT GROUNDING

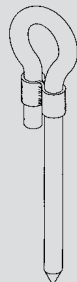

66 Series

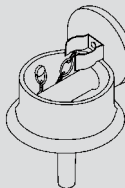

B166

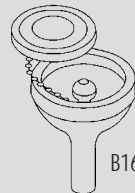

B165

GROUND BARS

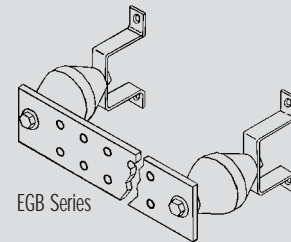

EGB Series

CONNECTORS & TOOLS

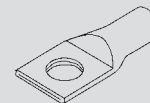

Lug

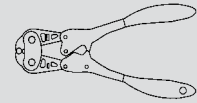

T031DJ

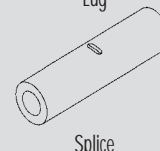

Splice

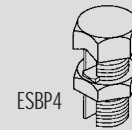

ESBP4

Specifications For Static Grounding

All materials such as conductors, clamps and connectors shall be sized properly and installed correctly to conduct and dissipate static charges in a harmless way. Non-inductive resistance may be added in some applications. Manufacturer's recommendations regarding component selection and installation shall be followed except where superseded by engineer's specifications.



Static Grounding and Bonding

Static Grounding Conductors

ERITECH® Cables

A805A01F Series

Bare Bronze Cable, Extra Flexible, 3/16" Diameter

Part No.	Length
A805A01F-5	5' Cable
A805A01F-10	10' Cable
A805A01F-20	20' Cable

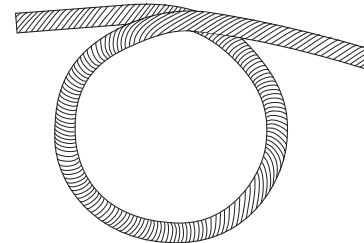

A806A3F Series

Orange Insulated Bronze Cable, Extra Flexible, 3/16" Diameter

Part No.	Length
A806A03F-5	5' Cable
A806A03F-10	10' Cable
A806A03F-20	20' Cable

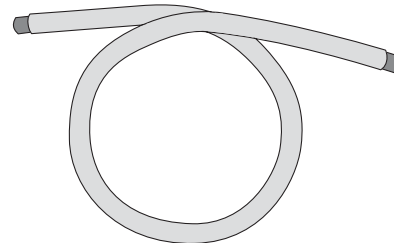

A822SAS Series

Bare Stainless Steel Cable, 1/8" Diameter

Part No.	Length
A822SAS-5	5' Cable
A822SAS-10	10' Cable
A822SAS-20	20' Cable

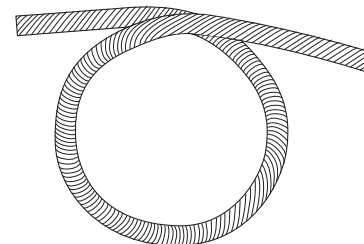

ERITECH Cable Reels and Coils

A822SA111C Series

Galvanized steel, 1/8" Orange Insulated Coiled Cable

Part No.	Length
A822SA111C-5	5' Cable
A822SA111C-10	10' Cable
A822SA111C-20	20' Cable

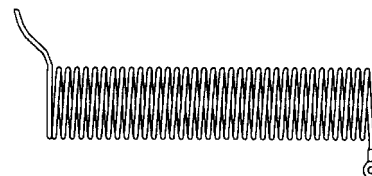

Static Grounding and Bonding

Static Grounding Conductors & Clamps

ERITECH® Cable Reels and Coils

A822SB11C

Galvanized steel, 3/16" Orange Insulated Coiled Cable

Part No.	Length
A822SB11C20	20' Cable

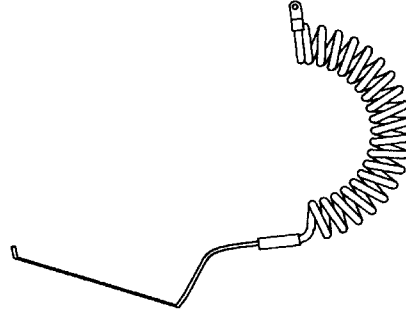

20' Cable Reel B2618A

Cable Length: 20', Cable Size: 3/32" Dia. Bare Stainless Steel, Bare Bronze Cable, Extra Flexible

Features

Two 1/4" bolt holes to affix
Uses only one cable terminator.
Other end of cable is grounded through metal reel case.
Plated bolting surfaces and base.

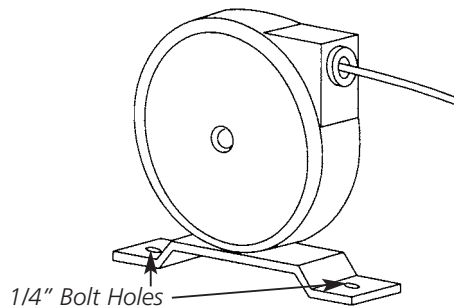

50' Cable Reel B2618B

Cable Length: 50', Cable Size: 3/32" Dia. Bare Stainless Steel

Features

Two 1/2" bolt holes to affix
Uses only one cable terminator.
Other end of cable is grounded through metal reel case.
Plated bolting surfaces and base.

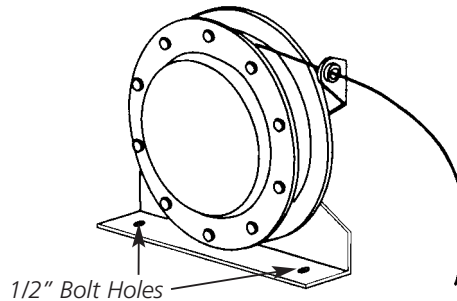

ERITECH Static Grounding Clamps

B2610A Spring Clamp (Fig. 64)

Bare Bronze Cable, Extra Flexible

- Die Cast Aluminum
- Max Jaw Opening: 1"
- Throat Depth: 1"
- Max Cable Size: 1/8"
- Contact Points: 2 ea., Stainless Steel
- Release Harness: Not Available

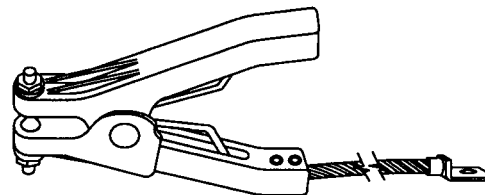

FM APPROVED

Figure 64.



Static Grounding and Bonding

Static Grounding Clamps

ERITECH® Static Grounding Clamps

B2611A Spring Clamp (Fig. 65)

- Die Cast Aluminum
- Max Jaw Opening: 1-1/2"
- Throat Depth: 2"
- Max Cable Size: 3/16"
- Contact Points: 3 ea., Stainless Steel
- Release Harness: Included

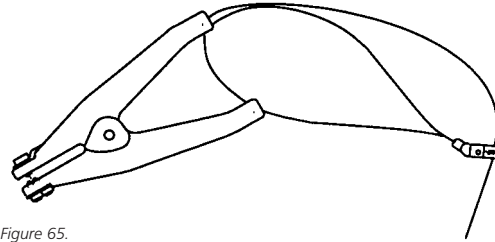

Figure 65.

B2614A Spring Clamp (Fig. 66)

- Bronze
- Max Jaw Opening: 1"
- Throat Depth: 2-1/2"
- Max Cable Size: 3/16"
- Length: 9-1/2"
- Contact Points: 3 ea., Stainless Steel
- Release Harness: Included

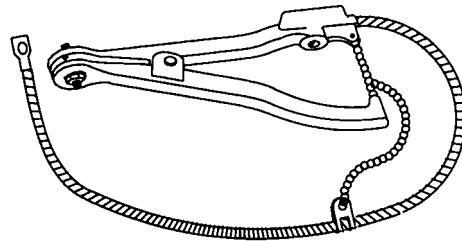

Figure 66.

B2617A Aircraft Grounding Clamp (Fig. 67)

- Die Cast Aluminum
- Max Jaw Opening: 3/4"
- Throat Depth: 5/32"
- Max Cable Size: 4-1/2"
- Contact Points: Plated Steel
- Release Harness: Not Available
- Fits rods up to 3/4" and CADWELD® Aircraft Grounding
- Receptacles B165 and B166

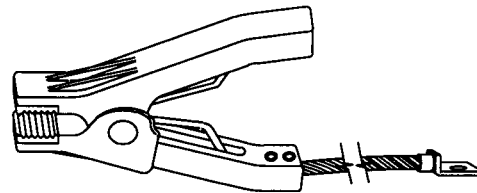

Figure 67.

ERITECH "C" Clamps

"C" Clamp B2615B (Fig. 68)

- Bronze
- Max Jaw Opening: 1-1/4"
- Throat Depth: 1-1/2"
- Max Cable Size: 3/16"
- Length: 2-1/2"
- Contact Point: Bronze, Includes Crimp Lug

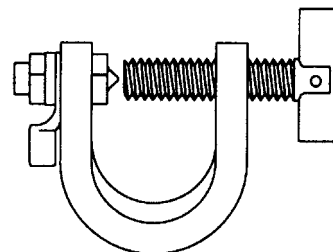

Figure 68.

Static Grounding and Bonding

Static Grounding Clamps

ERITECH® "C" Clamps

Heavy Duty "C" Clamps (Fig. 69)

- Painted Steel
- Max Jaw Opening: 3/8"
- Throat Depth: 1/2"
- Max Cable Size: 3/16"
- Length: 3"
- Contact Points: Hardened Steel
- Includes 5' of 3/16" orange insulated bronze cable welded to the clamp with heat shrink over weld area

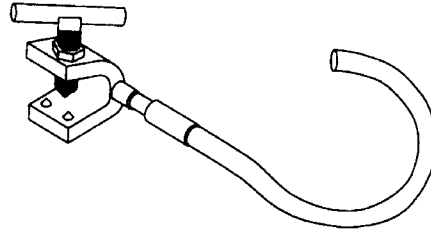

Figure 69.

"C" Clamp B2615A (Fig. 70)

- Bronze
- Max Jaw Opening: 2"
- Throat Depth: 2"
- Max Cable Size: 3/16"
- Length: 6"
- Contact Points: Carboloy
- Includes Cable Clamp

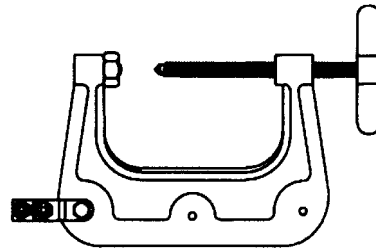

Figure 70.

ERITECH Pipe Clamps

B2616A Series Pipe Clamps

- Bronze
- Pipe Clamps: Individual Clamps to fit pipes from 1/2" to 6".
- Max Cable Size: 3/16"
- Use lug to connect to clamp.

Part No.	Pipe Size	Figure
CWP1J	1/2"-1"	71
B2616A-20	1-1/4"	72
B2616A-24	1-1/2"	72
B2616A-32	2"	72
B2616A-40	2-1/2"	72
B2616A-48	3"	72
B2616A-64	4"	72
B2616A-96	6"	72

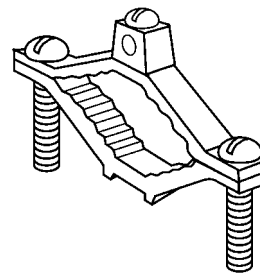

Figure 71.

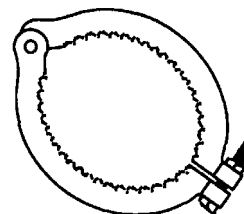

Figure 72.



Static Grounding and Bonding

Static Grounding Components

ERITECH® Copperbonded Aircraft Tie Down Rods

Specifications

663400 Nominal 3/4" diameter x 10' length

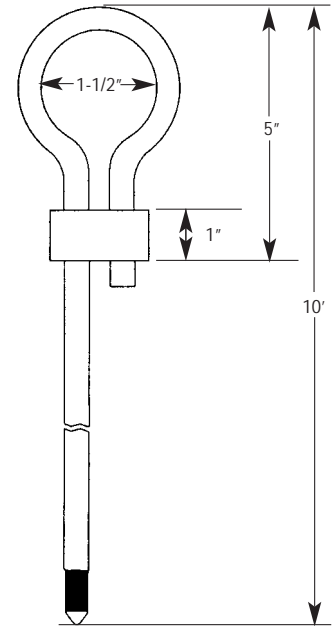

ERITECH Depression Mold DM5834

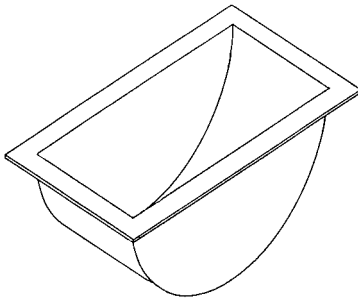

Plastic for making 3" x 6" x 2.5" deep depression in concrete pour around loop in aircraft tie-down.

ERITECH Aircraft Grounding receptacles for CADWELD® Process

- Copper alloy castings for use in static grounding systems of aircraft refueling areas
- Easily connected to grounding system conductor and/or ground rods
- Designed for simple installation with flush paved surfaces
- 3/4" cast ball, 3/4" removable ball, 3/4" cast bar or 1-1/2" bar attachment points available

B165	Depth A, from grade to level of support	4-1/2"
	Diameter C at grade level	2-3/4"
	Attachment Point	Cast 3/4" ball
B165R	Depth A, from grade to level of support	4-1/2"
	Diameter C at grade level	2-3/4"
	Attachment Point	Removable 3/4" ball
B166	Depth A, from grade to level of support	6-1/4"
	Diameter B, maximum ring size	4-3/4"
	Diameter C at grade level	3-7/8"
	Attachment Point	3/4" diameter
B167	Depth A, from grade to level of support	7-1/4"
	Diameter B, maximum ring size	6-1/2"
	Diameter C at grade level	4-3/4"
	Attachment Point	1-1/2" diameter

- Notes:
1. Aircraft static grounding clamp B2617A can be used to connect to the B165, B165R and B166.
 2. See Catalog A1A for CADWELD connections to aircraft grounding receptacles.

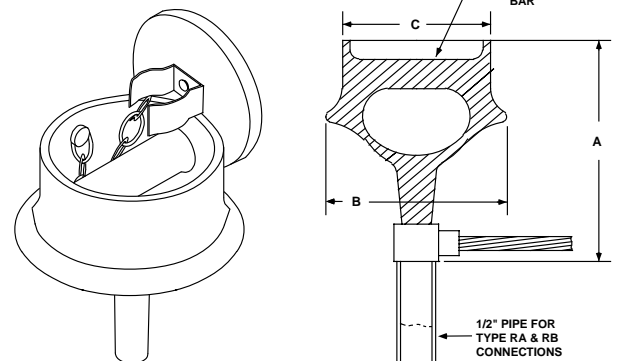
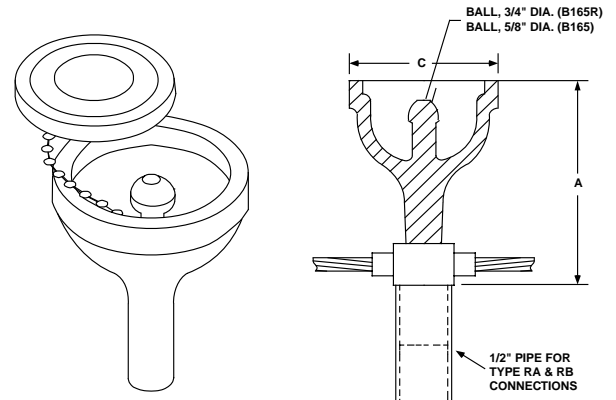

Static Grounding and Bonding

Static Grounding Components

ERITECH® Aircraft Grounding Receptacles for Sectional Ground Rods

LPC680

- Cast bronze aircraft receptacle
- Standard pin connection
- Chain retained cover plate
- Couple directly to 3/4" sectional rod or 3/4" extension rod
- Install flush with finish floor surface

LPC681

- Cast bronze aircraft receptacle
- Standard pin connection
- Chain retained cover plate
- Spring clip to secure cover plate
- Couple directly to 3/4" sectional rod or 3/4" extension rod
- Install flush with finish floor surface

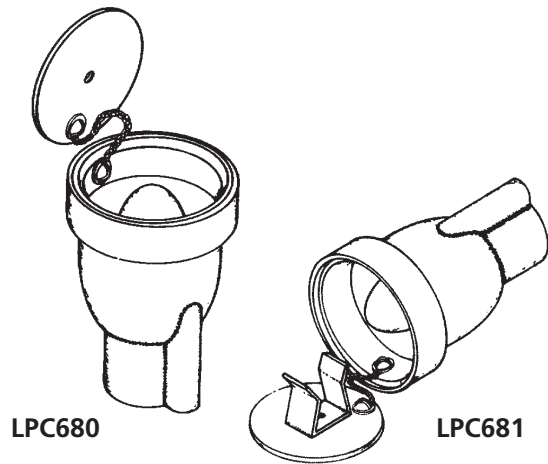

ERITECH B750A Static Grab Bar

- Stainless Steel
- Length: 18"
- Furnished with 6' of 1/0 AWG copper conductor with a tinned copper lug
- CADWELD® lug attached for connecting to the ground system.

Application - Touch before entry into static controlled assembly area.

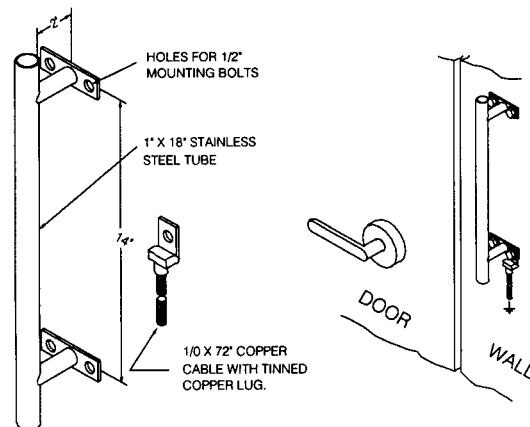

ERITECH B750A Metal Door Bond

- Bond Part Number B570A12 (12")
- CADWELD Mold with Frame and Flint Ignitor: VET012
- CADWELD Weld Metal: #25

Application - Industrial metal doors can be bonded to metal door frames with ERICO 3/16" bronze flexible cable. The connections are made to the door and door frame using the CADWELD process.

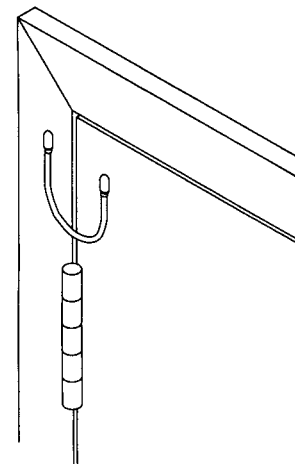

Ground Test Equipment

Applications

ERICO® Inc. offers a complete range of Ground/Earth Resistance Testers. The units are lightweight and portable for ease of use in the field. Their robust design and splash-proof construction help them withstand extreme conditions. The units' large LCD display shows required test connections and features a complete automatic test sequence for selected operations.

Three units are offered in the range. The Handy Earth Tester EST101 is a small handheld unit that can complete the 2-pole resistance measurement and the 3-pole earthing resistance measurement, as well as a ground to neutral impedance test.

The Earth System Tester EST201 is a slightly larger yet still portable unit and adds the capability to perform 4-pole resistance measurements for the determination of soil resistivity.

The Universal Earth System Tester EST301 provides the same measurement capabilities as the EST201 in addition to clamp-on selective and stakeless measurement capabilities. Clamp-on selective provides the ability to measure the resistance of interlinked ground/earth systems without the influence from parallel ground paths. This capability is ideal for systems which are permanently bonded using CADWELD® exothermically welded connections.

The ESTREELKIT500 is a set of two 500' long test leads on heavy-duty reels, ideal for three point fall-of-potential measurements at large sites.

No matter what the application, there is sure to be a Ground Tester suited to fit your many diverse ground/earth measuring needs.



EST101 – Handy Ground Tester

- 2 pole resistance and 3 pole ground/earth resistance measurements @128Hz
- GTN adapter cable provides Ground to Neutral impedance tests on live circuits per IEEE Std. 1100-1992
- Provided as a complete kit which includes required cables, leads, ground stakes, carrying case and carry belt
- Large high contrast liquid crystal display with easy to understand graphics and symbols
- Microprocessor controlled to automate the measuring process
- Lightweight and portable for ease of use in the field
- Automatic recognition of connection of measuring leads and its connections to earth



EST201 – Ground System Tester

- 2 pole resistance and 3 pole ground/earth resistance measurements @94/105/111/128Hz
- 4 pole resistance measurement for determining soil resistivity
- Provided as a complete kit which includes required cables, leads, ground stakes, carrying case and Grounding Tutorial book
- Large high contrast liquid crystal display with easy to understand graphics and symbols
- Microprocessor controlled to automate the measuring process
- Lightweight and portable for ease of use in the field
- Automatic recognition of connection of measuring leads and its connections to earth

Ground Test Equipment



EST301 – Universal Ground System Tester

- 2 pole resistance and 3 pole ground/earth resistance measurements @94/105/111/128Hz
- 4 pole resistance measurement for determining soil resistivity
- Clamp-on selective and stakeless measurement capabilities with clamp
- Large high contrast liquid crystal display with easy to understand graphics and symbols
- Microprocessor controlled to automate the measuring process
- Lightweight and portable for ease of use in the field
- Automatic recognition of connection of measuring leads and its connections to earth

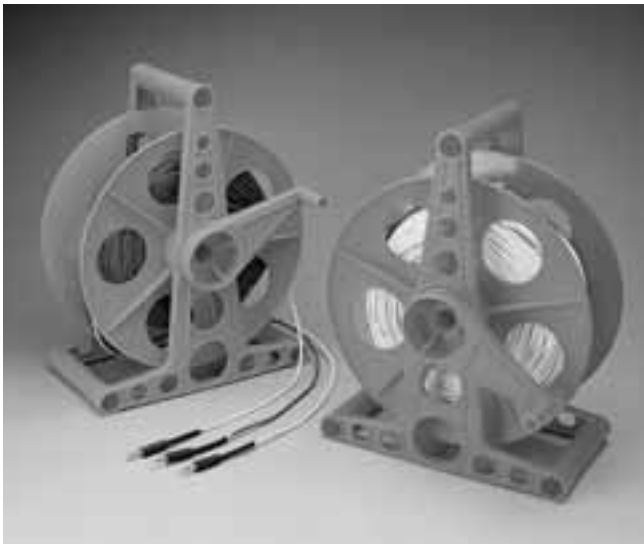

ESTREELKIT500 - Cable Reels

- 2 Heavy Duty insulated thermoplastic 11" diameter reels with integral carrying handle, rugged base, and cranks for fast test lead retrieval
- Test Leads are marked every 25 feet for easy auxiliary ground test stake positioning
- 500 feet of #18 Silicone Rubber Insulated Wire on each reel, two different colors for easy stake identification
- The far end of test lead remains attached to reel base, which eliminates tangling and speeds up the process of test stake deployment. A jack built into the reel base connects the test lead to the test stake with an included jumper

Grounding Products and Systems

Technical Section

ERITECH® Copper Bonded and Hot Dipped Galvanized Ground Rods

1.0 Copper Clad Ground Rods

ERITECH copper clad steel ground rods are manufactured in diameters of 1/2", 5/8", 3/4" and 1". They are available in pointed or sectional (threaded) finishes as well as different thickness of plating.

1.1 Steel

1035 Steel – cold drawn to ASTM A1080 and AISI C1017 standards, except for 3/4", which uses 1018 steel. Tensile strengths are as follows:

Rod Diameter	Average	Range
3/8"	86,500 psi	75-95,000 psi
1/2"	86,500 psi	75-95,000 psi
5/8"	MIN. 90,000 psi	90,000 +
3/4"	MIN. 90,000 psi	90,000 +
1"	MIN. 90,000 psi	90,000 +

1.2 Copper Plating

The copper is applied electrolytically, forming a metallurgical bond between the steel core and the copper. The copper is type DHP alloy #122CDA and is rated at 99.95% copper. The end result is a high quality bond between copper, nickel and steel. ERITECH plates to thickness of 0.005", 0.010", and 0.013". For rods plated over 0.010" there is a tolerance of +.002" and -.00".

1.3 Finishing

1.3.1 Diameter: measurements based on finished plated product.

Rod Size	Average Diameter
1/2"	.500"
5/8"	.561"
3/4"	.677"
1"	.910"

1.3.2 Plating Thickness: the copper plating can be controlled to the following thickness levels and is continuous over the rod with the exception of the pointed and chamfered ends.

Mil Thickness	Average Diameter
5 mil	.0050"
10 mil	.010"
13 mil	.013"

1.3.3 Machining:

Standard pointed rods are conical pointed to 60 degrees on one end and are cut square and chamfered at the other end. Sectional threaded rods are roll-threaded to provide American Standard course thread requirements with a class 2 fit. One end of a sectional rod is threaded with a "flat" point and the other end is a threaded chamfered end. Standard lengths are 6, 8, and 10 feet with a tolerance of +5/8" and -0".

1.4 Marking of Rods

Each rod is imprinted within 12" of the top of the rod with: part number indicating rod diameter and length, manufacturer logo and UL mark (when listed).

1.5 Packaging

Ground rods shall be packaged in bundles with reinforced tape or metal banding and then bound securely in steel strapped master bundle.

Rod Size	Bundle Quantity	Master Bundle Quantity
1/2"	10	100
5/8"	10	100
3/4"	5	50
1"	1	25

1.6 References

Underwriters Laboratories UL 467
National Electrical Manufacturers Association NEMA 8CC-5/GR-1
American National Standards Institute ANSI C33-8
ASTM A1080; AISI C1017 for steel
Naval Facility Engineering Command NAVFACENGCOM12.1
Military Handbook MILHANDBOOK419
RUS – 13 mil. Thick coating only

2.0 Hot Dipped Galvanized Ferrous Ground Rods

ERITECH hot dipped galvanized ground rods are manufactured in diameters of 1/2", 5/8", 3/4" and 1" and are only available with a pointed finish.

2.1 Steel

Hot rolled carbon 1018/1035 steel core shall be in accordance with ASTM A-36. Steel shall have a tensile range of 58,000 – 80,000 PSI.

Technical Section

2.2 Plating

The zinc coating will be hot dipped galvanized in accordance with ASTM A153-78.

2.3 Finishing – ground rods shall be free of seams, slivers and other injurious defects.

2.3.1 Diameter and Permissible Variations:

Rod Size Inch	Diameter Tolerance (Inch)
1/2"	+ .010-.020
5/8"	+ .010-.030
3/4"	+ .010-.030
1"	+ .010-.030

2.3.2 Length and Permissible Variations:

Rod Size Inch	Length (feet)	Length Tolerance (Inches)
1/2"	5, 6	+/- 1
5/8"	6, 8	+/- 3
3/4"	6, 8, 10	+/- 3
1"	8, 10	+/- 3

2.3.3 Machining:

Standard rods are conical pointed to 60 degrees on one end and are cut square and chamfered at the other end.

2.4 Marking of Rods

Each rod is imprinted within 12" of the top of the rod with: manufacturer logo, and part number indicating rod diameter and length.

2.5 Packaging

Ground rods shall be packaged in bundles with reinforced tape or metal banding and then bound securely in steel strapped master bundles.

Rod Size	Bundle Quantity	Master Bundle Quantity
1/2"	10	100
5/8"	10	100
3/4"	5	50
1"	1	25

3.0 References

National Electrical Manufacturers Association NEMA 8CC-5/GR-1
 ASTM A-36 for steel
 ASTM A153-78 for plating
 ANSI C135.30 – 1979
 RUS

ERITECH® Chemical Ground Rods

How to Specify a Chemical Ground Rod

The chemical ground rod shall be UL Listed to UL 467. It shall operate by hygroscopic extraction of moisture from the air to activate the electrolytic process to improve performance. The ground rod can be 100% self activated or initiated with the addition of water at time of installation. No additional water shall be required thereafter for the life of the system.

The ground electrode shall come in a kit, complete with all the components required to complete the installation. The electrode shall be constructed of copper tube with an internal diameter not less than 50.8 mm (2") and a wall thickness not less than 2.0 mm (0.08").

The tube shall be permanently capped on the bottom and have a removable cap on the top. The UL nameplate shall appear on the top cap. Air breather holes shall be provided in the top cap and drainage holes shall be provided along the length of the tube for drainage of electrolyte solution into the surrounding soil.

The ground electrode shall be a minimum of 10' long for vertical installations or for a horizontal (L shaped) installation be of no less than 10' on the horizontal with an access segment of 32" vertical

length. Where the requirement is for a length greater than 20', the sections shall be in segments of 10'.

There shall be a copper pigtail wire of not less than 4' in length permanently attached to the side of the tube via CADWELD®. The tube shall be pre-charged with salts of Calcium and Sodium in equal proportions. Bentonite clay shall be included in sufficient quantity to be placed around the bottom of vertically installed rods and around the horizontal section of L-shaped rods.

A permanent, stable, high conductivity, back-fill material that is hygroscopic in nature and will not shrink, contract or separate from the electrode due to loss of ambient soil moisture shall be provided in sufficient volume to fill the rest of the hole for the vertical installation and around the horizontal and vertical sections of the L-shaped rod. This material shall be a highly conductive compound composed of chemically stable materials including hydraulic cement, high quality calcined carbon and rheological additives.

An inspection well shall protect the chemical rod, while allowing necessary air and moisture to enter. It shall open easily for inspection and future recharging if required.



Technical Section

ERITECH® Fence Post and Gate Grounding Specifications

The IEEE Std 80-2000 discusses fence grounding in paragraph 17.3. Fence bonding and grounding are of major importance in substation grounding because:

1. Dangerous “touch” potentials are involved.
2. The outside of the fence is usually accessible to the public.
3. The fence is often at the edge of the ground grid, where the surface potentials are highest.

There are two methods used in designing the fence grounding system:

1. Tie the fence grounding system into the sub-station ground grid (Figure 73). This method must be used if the fence is within the ground grid area.
2. Use a separate fence ground if the fence is outside the ground grid area (Figure 74).

If the fence ground is tied to the grid, the grid size is increased, which reduces both the grid resistance and the ground grid voltage rise. However, the internal and perimeter gradients must be kept within safe limits because the fence is also at the full potential rise. This can

be accomplished by burying a perimeter conductor 3 to 4 feet outside the fence and bonding the fence and the conductor together at close intervals (Figure 75). The conductor could be buried under the fence line if one is unable to place it outside, but the touch potential for a person standing one meter outside the fence could exceed tolerable levels and be unsafe to touch. ⁽¹⁾

With the perimeter conductor one meter outside the fence, a worker standing inside the fence will have an increase in touch potential, but only about 10%.

If the fence is not connected to the main grid (Figure 74), one must consider:

1. Could an energized line fall on the fence?
2. Could other hazardous potentials exist during other types of faults?
3. Can the fence really be completely isolated from the main grid all the time, including future expansions?

⁽¹⁾ Based on IEEE Std. 80-2000 (17.3 case 2). Refer to paragraphs 17.3 and 17.4 to see effects of various grounding practices on fence touch potential.

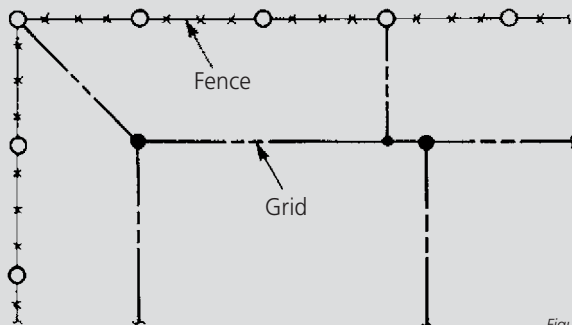

Figure 73.

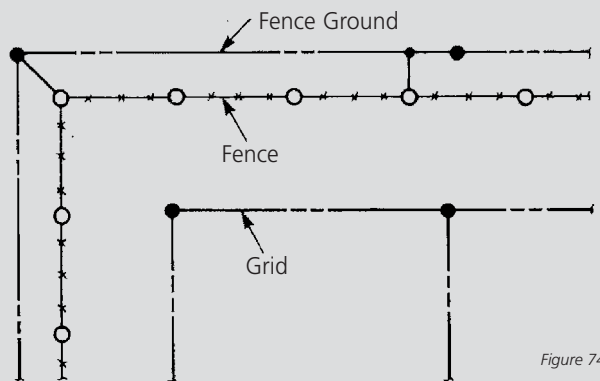

Figure 74.

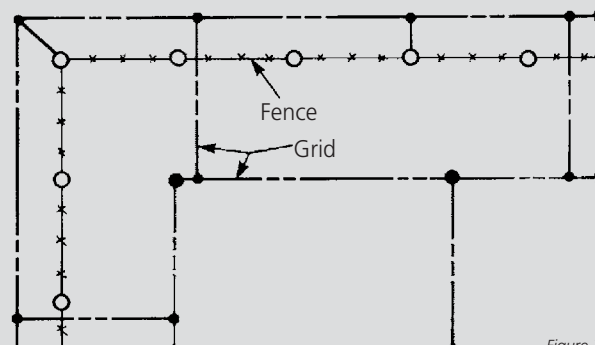

Figure 75.

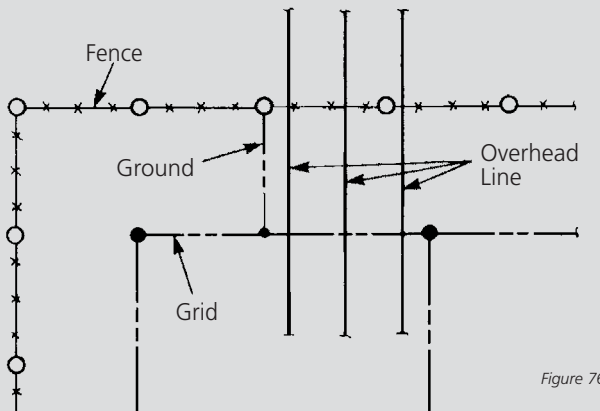

Figure 76.

Grounding Products and Systems

Technical Section

ERITECH® Fence Post and Gate Grounding Specifications

The **National Electrical Safety Code®** (NESC) and IEEE/ANSI C2-1997 contain several changes to the grounding requirements of fences from the previous editions. This edition requires per Rule 92E:

Fences that are required to be grounded by other parts of this code shall be designed to limit touch, step and transferred voltages in accordance with industry practices.

NOTE: IEEE Std 80-2000 is one source that may be utilized to provide guidance in meeting these requirements.

The grounding connections shall be made either to the grounding system of the enclosed equipment or to a separate ground. (See Figures 73, 74 & 75.)

1. Fences shall be grounded at each side of the gate or other opening. (See Figure 77.)
2. Gates shall be bonded to the grounding conductor, jumper of fence. (See Figure 77.)
3. A buried bonding jumper shall be used to bond across the gate or other opening in the fence, unless a nonconducting fence section is used. (See Figure 77.)
4. If barbed wire strands are used above the fence fabric, the barbed wire strands shall be bonded to the grounding conductor, jumper or fence. (See Figure 78.)
5. When fence posts are of conducting material, the grounding conductor shall be connected to the fence post or posts as required with suitable connecting means.
6. When fence posts are nonconducting material, a suitable bonding connection shall be made to the fence mesh strands and the barbed wire strands at each grounding conductor point. (See Figure 79.)

A second conductor, although not required by NESC, offers personnel protection if installed under the gate swing area as shown in Figure 77. It is also common practice to connect the ground to all fence corner posts and to the line posts every 50 feet.

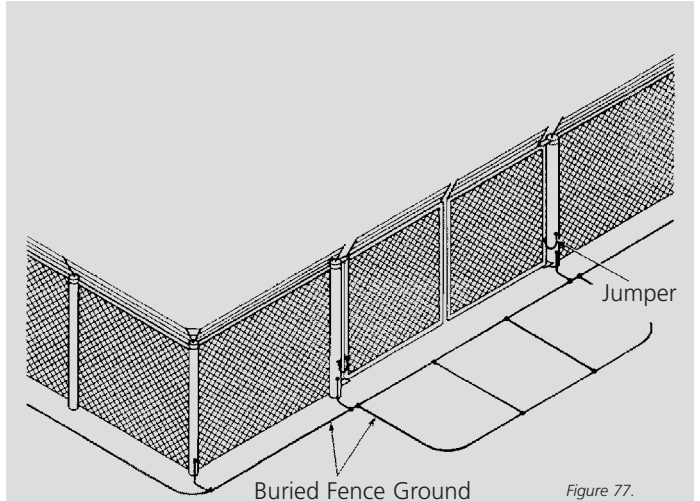

Figure 77.

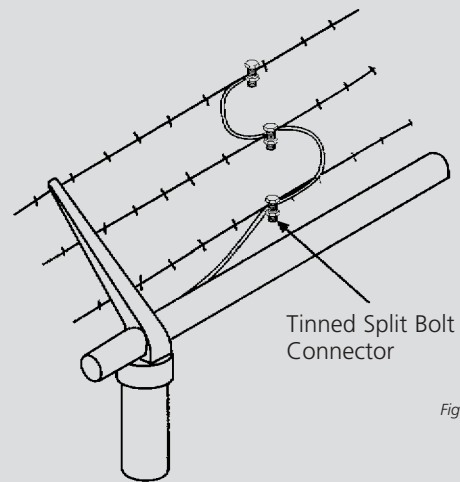

Figure 78.

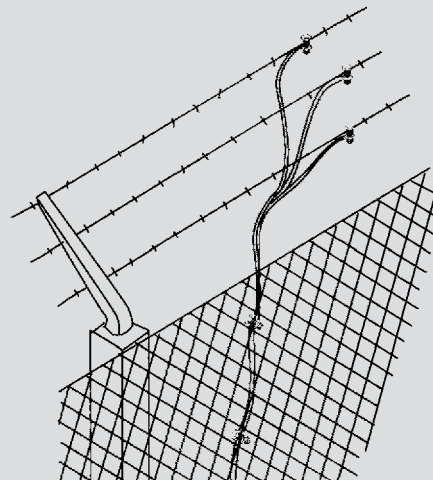

Figure 79.

® National Electronic Safety Code is a registered trademark of the National Fire Protection Association.



Technical Section

ERITECH® Signal Reference Grids (SRG) and Grounding for Computer Room Grounding

Introduction

Proper grounding and bonding of sensitive electronic systems, including computer installations, requires careful consideration of all frequencies from DC to over 100 megahertz. The National Electrical Code (NEC) requirements for fault current and NFPA lightning protection must also be met.

The safety grounding system ("green wire") required by Code does not address the special requirements of noise immunity. An additional "grounding" system called the Signal Reference Grid (SRG) is needed to assure trouble-free equipment performance. There is no conflict between NEC safety requirements and the need for an SRG to protect computer data.

The ERITECH Signal Reference Grid (SRG) is a low impedance network of conductors, which establish an equipotential plane for high frequency, low voltage digital signals. Since signal voltages are low, their sensitivity to transient noise is very high - typically 1 volt for digital systems. In order to minimize the effects of noise, many computer manufacturers, users and government agencies have detailed specifications regarding computer grounding. Welded connections are often specified because they are the only connections proven to ensure a "noise-free" bond. Normal shock and vibrations can jar mechanical connections, creating electronic noise. This causes relatively high $L di/dt$ voltages due to a sudden change in connection impedance. This sudden change can result in pulses that can be coupled into the signal circuits. These unwanted signals can create false data or even cause permanent circuit damage. Corrosion, dirt and cleaning fluids cannot interfere with the molecular bond of a welded joint.

Recommendations on ERITECH Signal Reference Grids are in full agreement with IEEE Std 1100-1999, IEEE Recommended Practice for Powering and Grounding Sensitive Electronic Equipment.

SRGs are required because computers are sensitive to noise voltages that have a broad frequency band. At these frequencies:

1. Distributed capacitance and mutual inductance cannot be ignored. Coupling between adjacent power and data circuits and ground may introduce noise into data cables. Even nearby lightning strikes can be a real threat to proper operation.
2. Radiated fields are usually not a threat with the exception of nearby transmitters, which may be a serious problem and require shielding.
3. An effective SRG has a multitude of conductors creating a very low impedance to noise at any frequency.
4. Termination must be a constant low impedance over the life of the facility. Welded connections are therefore needed so the ground path never changes.
5. The multiple paths within the SRG allow noise currents to divide at each crossover, which further reduces voltage drop.

Other means of creating a Signal Reference Grid exist. For example, brazed copper mesh made of round copper or copper clad wire has been used successfully. Mesh is commonly buried in the structural floor but it often costs more than flat strip SRGs. Raised floor stringers have been used but they have a tendency towards loose connections and low capacitance to computer cables. The result is higher impedance and less predictable performance.

The flat strip SRG is the most functional low-impedance and cost-effective computer grounding system available. Compared to the cost of equipment or the cost of corrupted information, an ERITECH SRG is the best data insurance you can buy.

Technical Section

ERITECH® Signal Reference Grids (SRG) and Computer Room Grounding

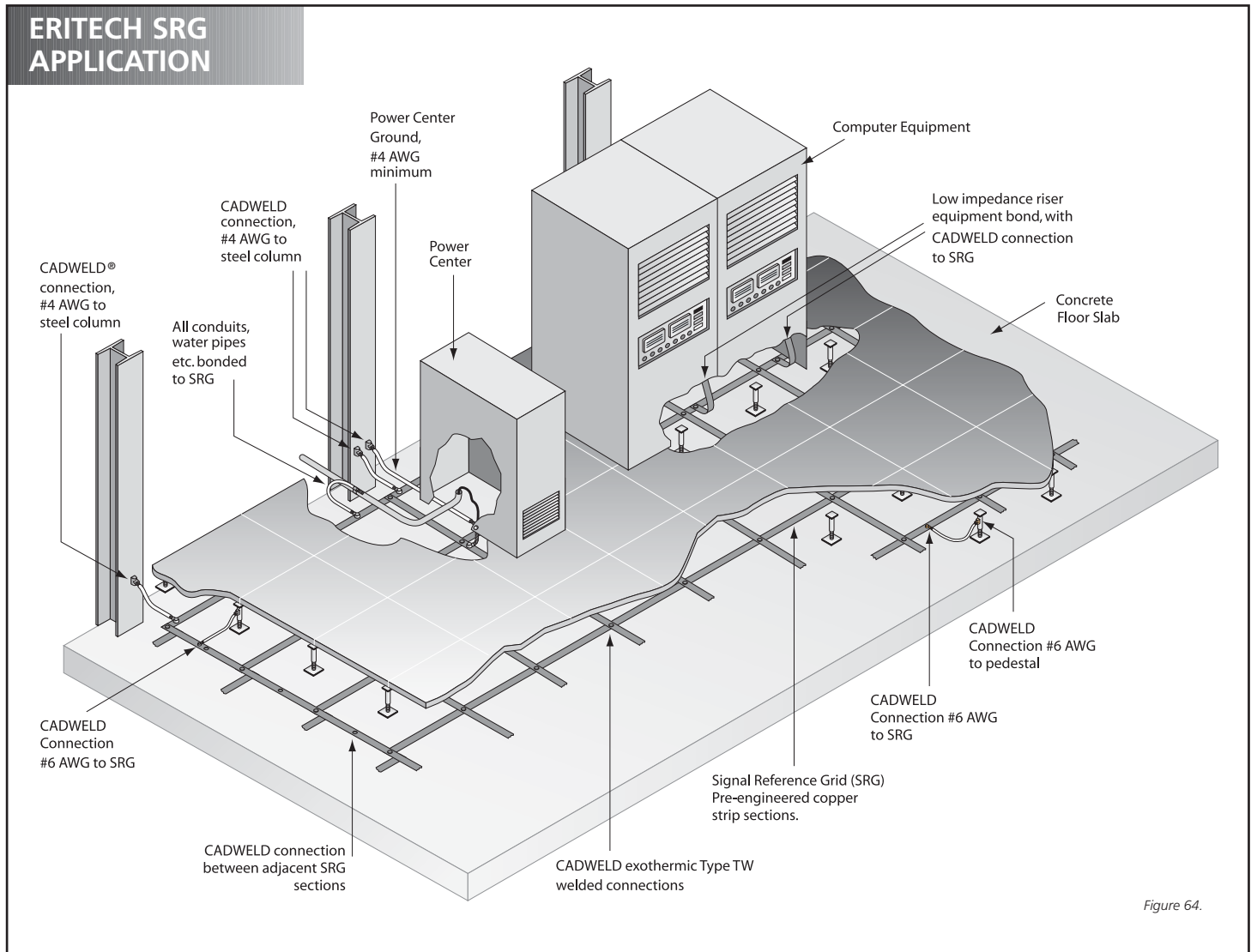

NOTES:

1. NEC and local codes must be followed.
2. All equipment shall be bonded to the ERITECH SRG using low impedance risers. Never connect to strip closest to outside wall.
3. All raised floors within the computer room should be bolted stringer type.
4. Every 6th raised floor pedestal in each direction shall be connected to the SRG using a #6 AWG concentric copper conductor. The connection to both the pedestal and the SRG shall be CADWELD.
5. All columns, conduits, water pipes, ducts, etc. entering the computer room shall be bonded to the SRG (at each end of the room if these are horizontal).
6. Power distribution panels and power distribution center should be mounted directly to the building steel or bonded to it by a short length of grounding conductor equal to the "green wire ground" but at least a #4 AWG copper. The grounding wire inside any panel or enclosure supplying AC power to the computer must be bonded to its enclosure.



Grounding Products and Systems

Technical Section

ERITECH® Signal Reference Grids (SRG) and Computer Room Grounding

Impedance

The following chart lists calculated impedances for various conductors at 20 MHz.

Note that 26 gauge x 2" strip has a lower impedance than a 4/0 conductor, even though it is only 1/5 the cross sectional area.

Conductor Size	Conductor Type	IMPEDANCE IN OHMS		
		12" Length	24" Length	36" Length
#6 AWG	7 STRAND	35 OHMS	81 OHMS	130 OHMS
#4 AWG	7 STRAND	33	77	125
1/0 AWG	7 STRAND	30	70	114
4/0 AWG	7 STRAND	27	64	106
16GA x 1.5"	STRIP	25	61	100
16GA x 2"	STRIP	23	56	94
26GA x 2"	STRIP	23	57	94

NOTE: Only 26 gauge is available prefabricated. All other thicknesses must be field fabricated.

REFERENCES

IEEE Std 1100-1999, "IEEE recommended Practice for Powering and Grounding Sensitive Electronic Equipment"

Grounding, Bonding and Shielding for Electronic Equipment and Facilities.

MIL-HDBK-419-A, Department of Defense, Washington, DC 20301. 29 December 1987.

Grounding, Bonding and Shielding for Long Haul/Tactical Communications Systems Including Ground Based Communications - Electronics Facilities and Equipment. MIL-STD-188-124A, Department of Defense, Washington, DC 20301. 02 February 1984.

ANSI/NFPA 70-1999, "National Electrical Code" (NEC), National Fire Protection Association, Boston, MA 02201.

Grounding Products and Systems

Technical Section

Grounding System - Conductors and Connectors

The grounding conductor size is based on the maximum magnitude and duration of available fault current and on the type of connections being used in the grounding system. IEEE Std. 80-2000, Guide for Safety in Substation Grounding, the accepted industry standard, uses a fusing formula as the basis for selecting minimum conductor size to avoid fusing (melting) under fault conditions.

This formula can be simplified to the following:

$$A = K \cdot I \sqrt{S}$$

- Where: A = Conductor size in circular mils
 K = Constant from the following table
 I = RMS fault current in amperes
 S = Fault time in seconds

Based on the standard ambient temperature of 40°C.

MAX TEMP	CONSTANT K FOR ABOVE FORMULA		
	COPPER S.D.	COPPERWELD DSA 40%	COPPERWELD DSA 30%
1083 C	7.01	10.46	12.04
450 C	9.18	13.74	15.87
350 C	10.10	15.13	17.46
250 C	11.65	17.47	20.17

The temperatures listed above for each material are specified in IEEE Std. 80-1986 to be used for different types of connecting means:

- Pressure type connectors 250° to 350°C*
- Brazed connections 450°C
- Exothermic welded connections 1083°C

*except those which have been tested to and passed the requirements of IEEE Std. 837-1989.

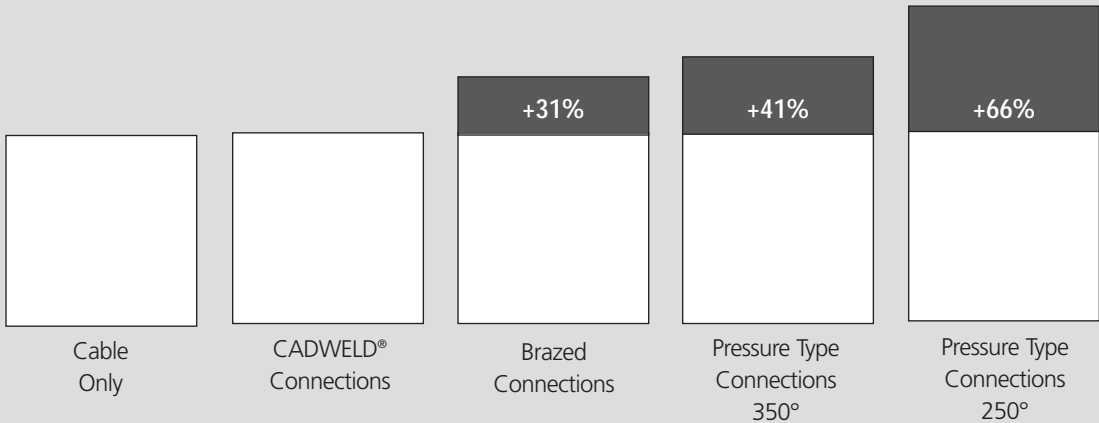

EXAMPLE – 25,000 Ampere, 2 second fault:

CONNECTION TYPE	CONDUCTOR SIZE
CADWELD	.246 kcmil – use 250 kcmil
Brazed	.322 kcmil – use 350 kcmil
Pressure Type (at 350°C)	.357 kcmil – use 350 kcmil
Pressure Type (at 250°C)	.408 kcmil – use 400 kcmil



Grounding Products and Systems

Technical Section

Bare Class A, B, and C Concentric Stranded Conductor (Based on A.S.T.M. Standard Specifications)

Size in Circular mils	Size A.W.G.	Conductor Dia. In.	NUMBER OF WIRES					CADWELD® Cable code
			7	19	37	61	91	
1,000,000		1.152			.1644*	.1280	.1048	4Y
800,000		1.031			.1470*	.1145	.0938	4Q
750,000		.998			.1424*	.1109	.0908	4L
700,000		.964			.1375*	.1071	.0877	4G
600,000		.893			.1273	.0992	.0812	3X
500,000		.813		.1622*	.1162	.0905		3Q
400,000		.728		.1451	.1040	.0810		3H
350,000		.681		.1357	.0973	.0757		3D
300,000		.630		.1257	.0900	.0701		3A
250,000		.575		.1147	.0822	.0640		2V
211,600	4/0	.528	.1739	.1055	.0756			2Q
167,800	3/0	.470	.1548	.0940	.0673			2L
133,100	2/0	.419	.1379	.0837	.0600			2G
105,500	1/0	.373	.1228	.0745	.0534			2C
83,690	1	.332	.1093	.0664	.0476			1Y
66,370	2	.292	.0974	.0591				1V
52,630	3	.260	.0867	.0526				1Q
41,740	4	.232	.0772	.0469				1L
26,240	6	.184	.0612	.0372				1H
16,510	8	.146	.0486	.0295				1E
10,380	10	.116	.0385	.0234				1B
6,530	12	.0915	.0305	.0185				
4,110	14	.0726	.0242	.0147				

*Class AA

Grounding Products and Systems

Technical Section

Bare Solid Copper Wire

(Based on A.S.T.M. Standard Specifications)

Size AWG	Cross Sectional Area Circular Mills	Wire Dia. In.	CADWELD® Cable code
4/0	211,600	.4600	2P
3/0	167,800	.4096	2K
2/0	133,100	.3648	2F
1/0	105,500	.3249	2B
1	83,690	.2893	1X
2	66,370	.2576	1T
3	52,630	.2294	1P
4	41,740	.2043	1K
6	26,250	.1620	1G
8	16,510	.1285	1D
10	10,380	.1019	1A
12	6,530	.0808	
14	4,110	.0664	

DSA Copperweld Conductor

Cable Stranding	Nominal Diameter	kcmil	Equivalent Copper Size*	CADWELD Cable code
7/#10	.306	72.7	3AWG	9A
7/#8	.385	115.6	1	9B
7/#7	.433	145.7	1/0	9C
7/#6	.486	183.8	2/0	9D
7/#5	.546	231.7	3/0	9E
19/#9	.572	248.8	3/0	9F
7/#4	.613	292.2	4/0	9L
19/#8	.642	313.7	4/0	9G
19/#7	.721	395.5	250 Kcmil	9H
37/#9	.801	484.4	300	7W
19/#6	.810	498.8	350	9J
37/#8	.899	610.9	400	7V
19/#5	.910	628.9	450	9K
37/#7	1.010	770.3	500	9M

*Approximate based on Fusing Current calculations and tests by Copperweld Co.

Bare Copperweld Conductor

Nominal Size	Material	Type	Thread Size	Body Dia.	CADWELD Ground Rod Code	
1/2"	Copperclad	Sectional	9/16"	.505	14	
	Steel*	Plain		.500	14	
	Copperclad	Plain		.475	15	
5/8"	Copperclad	Sectional	1/2"	.447	13	
	Copperclad	Sectional		5/8"	.563	16
	Steel*	Plain		.625	31	
3/4"	Copperclad	Plain	3/4"	.563	16	
	Copperclad	Sectional		.682	18	
	Steel*	Plain		.750	33	
1"	Copperclad	Plain	1"	.682	18	
	Copperclad	Sectional		.914	22	
	Steel*	Plain		1.000	37	
	Copperclad	Plain		.914	22	

* Plain steel, stainless steel, stainless clad rods or galvanized steel.



Grounding Products and Systems

Technical Section

Rectangular Copper Busbar

Thickness Inches	Width Inches	Circular Mil Size	Weight Lbs. per Foot	CADWELD® Busbar Code
1/8	1	159,200	.484	CE
	1-1/2	238,700	.726	CG
	2	318,300	.969	CH
3/16	1	238,700	.727	DE
	2	477,500	1.45	DH
1/4	1	318,300	.969	EE
	1-1/2	477,500	1.45	EG
	2	636,600	1.94	EH
	3	954,900	2.91	EK
	4	1,273,000	3.88	EM
3/8	1	477,500	1.45	GE
	1-1/2	716,200	2.18	GG
	2	954,900	2.91	GH
	3	1,432,000	4.36	GK
1/2	4	1,910,000	5.81	GM
	2	1,273,000	3.88	JH
	3	1,910,000	5.81	JK
	4	2,546,000	7.75	JM

Reinforcing Bars

Rebar Sizes	NOMINAL DIMENSIONS		Equivalent Copper Sizes*	CADWELD Rebar Code
	Dia. Inches	Cross-Sectional Area - Sq. Inches		
3	.375	.11	9AWG	51
4	.500	.20	7	52
5	.625	.31	5	53
6	.750	.44	3	54
7	.875	.60	2	55
8	1.000	.79	1	56
9	1.128	1.00	1/0	57
10	1.270	1.27	2/0	58
11	1.410	1.56	3/0	59
14	1.693	2.25	250 kcmil	60
18	2.257	4.00	450	61

* Based on 8% IACS, rounded to the next higher commercial copper size.

USEFUL CONVERSIONS

Area

Square Inches x 1273 = kcmil

Square Millimeters x 1.974 = kcmil

kcmil x 0.5067 = Square Millimeters

Density

Copper: 0.323 lb/in³

Steel: 0.283 lb/in³

Grounding Products and Systems

Technical Section

Standard Steel Wire Gauge

(WASHBURN MOEN GAUGE) SOLID

Gage No.	Dia. Inches	Gage No.	Dia. Inches
7/0	.490	6	.1920
6/0	.4615	7	.1770
5/0	.4305	8	.1620
4/0	.3938	9	.1483
3/0	.3625	10	.1350
2/0	.3310	11	.1205
1/0	.3065	12	.1055
1	.2830	13	.0915
2	.2625	14	.0800
3	.2437	15	.0720
4	.2253	16	.0625
5	.2070	17	.0540

Steel Pipe Sizes

STANDARD WEIGHT (SCHEDULE 40) ASTM A53-90-B
ANSI/ASME B36.10M-1985

Nominal Size In	O.D. Inches	Wall Thickness Inches	CADWELD® Mold Code
1	1.315	.133	1
1-1/4	1.660	.140	1.25
1-1/2	1.900	.145	1.50
2	2.375	.154	2
2-1/2	2.875	.203	2.50
3	3.500	.216	3
3-1/2	4.000	.226	3.50
4	4.500	.237	4
5	5.563	.258	5
6	6.625	.280	6
8	8.625	.322	8
10	10.750	.365	10

Cast Iron Pipe - Class A Thru D

AWWA Specification 1908, ASA A21.2 Class 100-250.

Nominal Size (Inches)	Actual O.D. (Inches)
4	4.80 to 5.00
6	6.90 to 7.10
8	9.05 to 9.30
10	11.10 to 11.40
12	13.20 to 13.50
14	15.30 to 15.70
16	17.40 to 17.80
18	19.50 to 19.90
20	21.60 to 22.10
24	25.80 to 26.30
30	31.70 to 32.70
36	38.00 to 39.20
42	44.20 to 45.60
48	50.50 to 52.00
54	56.70 to 58.40
60	62.80 to 64.80
72	75.30 to 76.90
84	87.50 to 88.50

Other Standard Sections used for Fence Posts

Section	CADWELD Mold Code
1-1/2" square	PS15
2" square	PS20
2-1/2" square	PS25
3" square	PS30*
1.875 x 1.625 x .133 "H"	PH1
2.25 x 1.95 x .143 "H"	PH2

* For D or F mold price only



ERICO® Facility Electrical Protection Literature

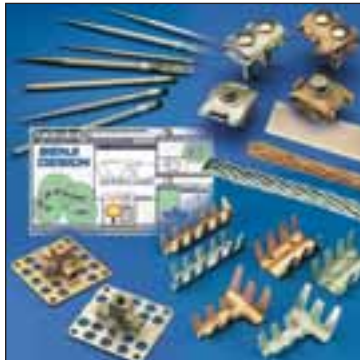

ERITECH® Lightning Protection Catalog

Features ERICO's System 2000 conventional lightning protection system as well as the System 3000 active lightning protection system. Air terminals, down conductors, fixing and fastening hardware and design consulting are covered.



ERITECH® Grounding Products Catalog

Details ERICO's extensive offering of ground rods and accessories, ground mesh and mats, signal reference grids, ground bars, ground receptacles, transient earth clamps, ground enhancement materials, and other grounding materials.



CADWELD® Welded Electrical Connections Catalog

Covers the range of hardware required to make a CADWELD connection as well as a comprehensive technical reference section on grounding principles. Detailed ordering information for molds, weld materials, fence and gate jumpers and the smokeless EXOLON process are detailed.



CRITEC® Surge Protection Catalog

Details the extensive range of CRITEC Surge Protection Devices for industries such as commercial & industrial, process control & automation and telecommunications. It also includes a comprehensive technical reference section on general aspects of surge protection as well as a guide on making the most appropriate product selection.

ERICO®



www.erico.com



AUSTRALIA

6 Chilvers Road
P.O. Box 148
Thornleigh (Sydney) NSW 2120
Australia
Phone 61-2-9479-8500
Fax 61-2-9484-9188



GERMANY

66851 Schwandenmühle
Germany
Phone 49-6307-918-10
Fax 49-6307-918-150



POLAND

ul. Krzemieniecka 17
54-613 Wrocław
Poland
Phone 48-71-374-40-22
Fax 48-71-374-40-43



BELGIUM

Postbus 33
3110 Rotselaar
Belgium
Phone 32-14-69-96-88
Fax 32-14-69-96-90



HONG KONG

Unit 1, 2nd Floor, Block A
Po Yip Building
62-70 Texaco Road
Tsuen Wan, New Territories
Hong Kong
Phone 852-2764-8808
Fax 852-2764-4486



SINGAPORE

Jurong Industrial Estate
16 Wan Lee Road
Singapore 627 946
Phone 65-6-268-3433
Fax 65-6-268-1389



BRAZIL

R. Dom Pedro Henrique de Orleans
E Braganca, 276
Vila Jaguara
São Paulo CEP 05117-000
Brazil
Phone 55-11-3621-4111
Fax 55-11-3621-4066



HUNGARY

P.f. 184
1476 Budapest
Hungary
Phone 31-13-58-34-547
Fax 31-13-58-35-499



SPAIN

C/Provenza 288, Pral.
08008 Barcelona
Spain
Phone 34-93-467-7726
Fax 34-93-467-7725



CANADA

P.O. Box 170
Mississauga, Ontario
Canada L5M 2B8
Phone 1-800-677-9089
Fax 1-800-677-8131



INDONESIA

Sampoerna Strategic Square,
Tower B 19th Fl.
Jalan Jend. Sudirman Kav. 45-46
Jakarta 12930
Indonesia
Phone 62-21-575-0941
Fax 62-21-575-0942



SWEDEN

Box 211
201 22 Malmö
Sweden
Phone 46-40-611-13-60
Fax 46-40-611-94-15



CHILE

Alcantara 200, piso 6 Of. 17
Las Condes, Santiago
Chile
Phone 56-2-370-2908
Fax 56-2-370-2914



ITALY

A&B Business Center
Via Valla 16, nr. 17
20141 Milano
Italy
Phone 39-02-8474-2250
Fax 39-02-8474-2251



SWITZERLAND

Postfach 54
3280 Murten
Switzerland
Phone 00-800-5000-1090
Fax 00-800-6000-1090



CHINA

Room 1204
Tomson Commercial Building
No. 710 Dongfang Road
Pudong, Shanghai
P.R. China 200122
Phone 86-21-5081-3900
Fax 86-21-5831-8177



MEXICO

Melchor Ocampo 193
Torre A piso 13
Col. Veronica Anzures
11300 Mexico D.F.
Mexico
Phone 52-55-5260-5991
Fax 52-55-5260-3310



THAILAND

163 Ocean Insurance Bldg.
16th Fl. Unit B
Surawongse Road
Bangrak Bangkok 10500
Thailand
Phone 66-2-634-1692
Fax 66-2-634-1694



DENMARK

Box 211
201 22 Malmö
Sweden
Phone 46-40-611-13-60
Fax 46-40-611-94-15



NETHERLANDS

Jules Verneweg 75
5015 BG Tilburg
Netherlands
Phone 31-13-58-35-400
Fax 31-13-58-35-499



UNITED KINGDOM

52 Milford Road
Reading, Berkshire RG1 8LJ
United Kingdom
Phone 44-118-955-0900
Fax 44-118-955-0925



FRANCE

rue Charles Dallière, BP 31
42161 Andrezieux Boutheon Cedex
France
Phone 33-4-77-36-54-32
Fax 33-4-77-55-20-10



NORWAY

Postboks 148
1366 Lysaker
Norway
Phone 47-67-53-12-00
Fax 47-67-12-42-68



UNITED STATES

34600 Solon Road
Solon, Ohio 44139
U.S.A.
Phone 1-440-248-0100
Fax 1-440-248-0723