



**Spectrum Research  
& Testing Lab., Inc.**

No. 101-10, Ling 8,  
Shan-Tong Li, Chung-Li  
City, Taoyuan, Taiwan,  
R.O.C.

# TEST REPORT

Reference No.: A06110803  
Report No.: FCBA05062302-02  
Page: 1 of 15  
Date: Nov. 08, 2006

Product Name: IDE  
Model No.: PE-111R, ST-135, UB-102DAi  
Applicant: LyCOM Technology Inc.  
4F-3, No. 48, BAU-CHIAU RD., HSIN-TIEN, TAIPEI HSIEN,  
TAIWAN, R.O.C.  
Date of Receipt: Nov. 08, 2006  
Finished date of Test: Not Available  
Applicable Standards: 47 CFR Part 15, Subpart B, Class B  
ANSI C63.4: 2003

We, **Spectrum Research & Testing Laboratory Inc.**, hereby certify that one sample of the above was tested in our laboratory with positive results according to the above-mentioned standards. The records in the report are an accurate account of the results. Details of the results are given in the subsequent pages of this report.

This report compared to original Report No.: FCBA05062302 issued on July 15, 2005 differs in Product Name and Model number. We regard it as a serial report.

Checked By : Stanley Chung, anth , Date: Nov. 8, 2006  
(Stanley Chung)

Approved By : J Ho , Date: 11/8/2006  
(Johnson Ho, Director)



Lab Code: 200099-0



## Table of Contents

1.	DOCUMENT POLICY AND TEST STATEMENT.....	3
1.1	DOCUMENT POLICY.....	3
1.2	TEST STATEMENT.....	3
1.3	EUT MODIFICATION.....	3
2.	DESCRIPTION OF EUT AND TEST MODE.....	4
2.1	GENERAL DESCRIPTION OF EUT.....	4
2.2	DESCRIPTION OF EUT INTERNAL DEVICE.....	4
2.3	DESCRIPTION OF TEST MODE.....	4
2.4	DESCRIPTION OF SUPPORT UNIT.....	5
3.	DESCRIPTION OF APPLIED STANDARDS.....	5
4.	CONDUCTED EMISSION TEST.....	6
4.1	CONDUCTED EMISSION LIMIT.....	6
4.2	TEST EQUIPMENT.....	6
4.3	TEST SETUP.....	7
4.4	TEST PROCEDURE.....	7
4.5	EUT OPERATING CONDITION.....	7
4.6	TEST RESULT.....	8
5.	RADIATED EMISSION TEST.....	9
5.1	RADIATED EMISSION LIMIT.....	9
5.2	TEST EQUIPMENT.....	9
5.3	TEST SET-UP.....	10
5.4	TEST PROCEDURE.....	11
5.5	EUT OPERATING CONDITION.....	11
5.6	RADIATED EMISSION TEST RESULT.....	12
6.	PHOTOS OF TESTING.....	13
7.	TERMS OF ABBREVIATION.....	15





## 1. DOCUMENT POLICY AND TEST STATEMENT

### 1.1 DOCUMENT POLICY

- The report shall not be reproduced except in full, without the written approval of SRT Lab, Inc.
- The report must not be used by the applicant to claim that the product is endorsed by NVLAP, TÜV, NEMKO and SRT.
- The NVLAP logo applies only to the applicable standards specified in this report.
- This Class [\*] digital apparatus complies with Canadian ICES-003.  
Cet appareil numérique de la classe [\*] est conforme à la norme NMB-003 du Canada.

### 1.2 TEST STATEMENT

- The test results in the report apply only to the unit tested by SRT Lab.
- There was no deviation from the requirements of test standards during the test.
- DC from PC : AC power source, 120 Vac/60 Hz, was used during the test.

### 1.3 EUT MODIFICATION

- No modification in SRT Lab.



## 2. DESCRIPTION OF EUT AND TEST MODE

### 2.1 GENERAL DESCRIPTION OF EUT

<b>PRODUCT</b>	IDE
<b>MODEL NO.</b>	PE-111R, ST-135, UB-102DAi
<b>POWER SUPPLY</b>	DC from PC
<b>CABLE</b>	N/A
<b>TYPE</b>	Prototype

**NOTE:**

The EUT has three model numbers as above on market. They are identical in all aspects except for different customers.

For more detailed information, please refer to the EUT's specification or user's manual provided by manufacturer.

### 2.2 DESCRIPTION OF EUT INTERNAL DEVICE

DEVICE	BRAND / MAKER	MODEL #	FCC ID/DOC	REMARK
POWER SUPPLY	SEVENTEAM	ST-402HCP	DOC	
CD-ROM	GIGABYTE	G0-C5200A	DOC	
MOTHERBOARD	ASUS	PSG01-VM-TAYOZ	--	
RAM	KINGSTON	KVR400X64C3A/256	--	
CPU	P4	3.0GHz	--	800MHz
HDD	WESTERN DIGITAL	WD400EB-42CPF0	--	--

**NOTE:**

1. The crystal clock is 25MHz.
2. Frequency range to be measured.  
Radiated emission is 30MHz to 1GHz.

### 2.3 DESCRIPTION OF TEST MODE

N/A (It is only applicable to more than one test mode.)



## 2.4 DESCRIPTION OF SUPPORT UNIT

The EUT was configured by the requirement of ANSI C63.4:2003 and CISPR 22:2003. All interface ports were connected to the appropriate support units via specific cables. The support units and cables are listed below.

NO	DEVICE	BRAND	MODEL #	FCC ID/DOC	CABLE
1	MONITOR	SAMSUNG	PG17IS	DOC	1.8m unshielded power cord 1.5m shielded data cable
2	PRINTER	EPSON	STYLUS C20SX	DOC	1.5m unshielded power cord 1.6m shielded data cable
3	MODEM	ACEEX	DM-1414	DOC	1.5m unshielded DC power cable 1.2m unshielded data cable
4	KEYBOARD	ACER	6312-TA4C/6	DOC	1.5m shielded data cable
5	MOUSE	COMPAQ	M-S34	DOC	1.5m shielded data cable

**NOTE:** For the actual test configuration, please refer to the photos of testing.

## 3. DESCRIPTION OF APPLIED STANDARDS

The EUT is a kind of ITE and according to the specifications provided by the applicant, it must comply with the requirements of the following standards:

47 CFR Part 15 Subpart B, Class B

All tests have been performed and recorded as per the above standards.



## 4. CONDUCTED EMISSION TEST

### 4.1 CONDUCTED EMISSION LIMIT

FREQUENCY (MHz)	Class A (dB $\mu$ V)		Class B (dB $\mu$ V)	
	Quasi-peak	Average	Quasi-peak	Average
0.15 - 0.5	79	66	66 - 56	56 - 46
0.5 - 5.0	73	60	56	46
5.0 - 30.0	73	60	60	50

**NOTE:**

1. The lower limit shall apply at the transition frequencies.
2. The limit decreases in line with the logarithm of the frequency in the range of 0.15 to 0.50 MHz.

### 4.2 TEST EQUIPMENT

The following test equipment was used for the test:

EQUIPMENT/ FACILITIES	SPECIFICATIONS	MANUFACTURER	MODEL#/ SERIAL#	DUE DATE OF CAL. & CAL. CENTER
EMI TEST RECEIVER	9 kHz TO 30 MHz	ROHDE & SCHWARZ	ESHS30/ 826003/008	AUG. 2005 ETC
LISN (for Peripheral)	50 $\mu$ H, 50 ohm	FCC	FCC-LISN-50-25-2/ 01018	NOV. 2005 ETC
LISN (for Peripheral)	50 $\mu$ H, 50 ohm	FCC	FCC-LISN-50-25-2/ 01018	NOV. 2005 ETC
50 ohm TERMINATOR	50 ohm	HP	11593A/ 2	OCT. 2005 ETC
COAXIAL CABLE	3m	SUNCITY	J400/ 3M	JUL. 2005 SRT
ISOLATION TRANSFORMER	N/A	APC	AFC-11015/ F102040016	N/A
FILTER	2 LINE, 30A	FIL.COIL	FC-943/ 771	N/A
GROUND PLANE	2.3M (H) x 2.4M (W)	SRT	N/A	N/A
GROUND PLANE	2.4M (H) x 2.4M (W)	SRT	N/A	N/A

**NOTE:** The calibration interval of the above test equipment is one year and the calibrations are traceable to NML/ROC and NIST/USA.



## 4.3 TEST SETUP

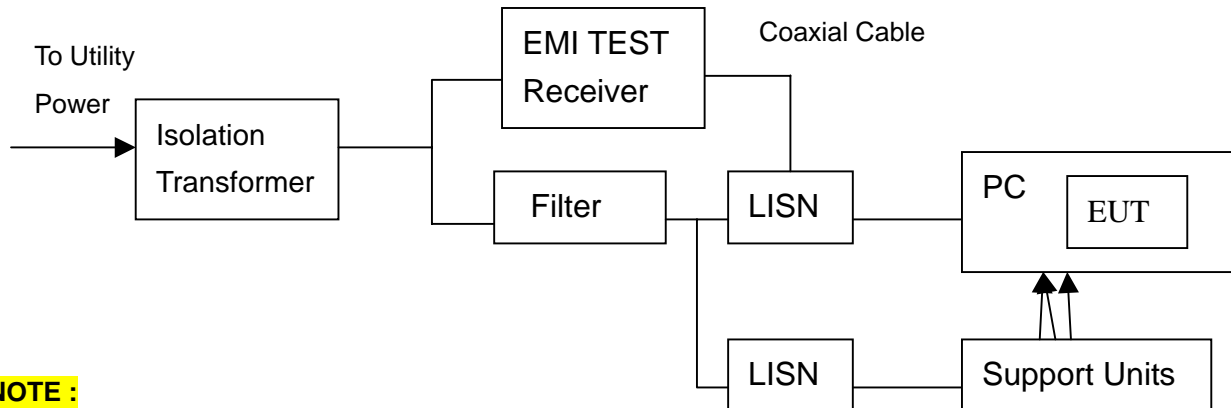

### NOTE :

1. The EUT was put on a wooden table with 0.8m height above ground plane, and 0.4m away from reference ground plane (> 2mx2m).
2. For the actual test configuration, please refer to the photos of testing.
3. The serial no. of the LISN connected to EUT is 01017.
4. The serial no. of the LISN connected to support units is 01018.

## 4.4 TEST PROCEDURE

The EUT was tested according to the requirement of ANSI C63.4:2003 and CISPR 22:2003. The frequency spectrum from 0.15 MHz to 30 MHz was investigated. The LISN used was 50 ohm/50 $\mu$ H as specified. All readings were quasi-peak and average values with 10 kHz resolution bandwidth of the test receiver. The EUT system was operated in all typical methods by users. Both lines of the power mains of EUT were measured and the cables connected to EUT and support units were moved to find the maximum emission levels for each frequency.

First, Find the margin or higher points at least 6 points by software, then use manual to find the maximum data. The procedure is referred on the test procedure of SRT LAB.

## 4.5 EUT OPERATING CONDITION

1. Under Windows XP ran "EMITEST", "Mediaplayer" and "XCOPY" programs.
2. EUT sent "H" pattern or accessed the following peripherals directly:
  - Color Monitor
  - RS232
  - Keyboard
  - Mouse
  - Printer
  - FDD
  - HDD
3. XCOPY  
:loop  
XCOPY C:\test E:\Vs/y  
Go to loop



## 4.6 TEST RESULT

Temperature:	27 °C	Humidity:	66 %RH
Ferquency Range:	0.15 – 30 MHz	Tested Mode:	N/A
Receiver Detector:	Q.P. and AV.	Tested By:	Oscar Lu
		Tested Date:	July 14, 2005

Power Line Measured : Line

Freq. (MHz)	Correct. Factor (dB)	Reading Value (dB $\mu$ V)		Emission Level (dB $\mu$ V)		Limit (dB $\mu$ V)		Margin (dB)	
		Q.P.	AV.	Q.P.	AV.	Q.P.	AV.	Q.P.	AV.
0.150	0.30	59.20	31.07	59.50	31.37	66.00	56.00	-6.50	-24.63
0.153	0.30	28.08	29.13	28.38	29.43	65.82	55.82	-37.44	-26.39
0.528	0.24	33.42	26.41	33.66	26.65	56.00	46.00	-22.34	-19.35
11.263	0.23	36.26	34.54	36.49	34.77	60.00	50.00	-23.51	-15.23
12.257	0.24	33.14	30.77	33.38	31.01	60.00	50.00	-26.62	-18.99
19.100	0.36	41.04	39.50	41.40	39.86	60.00	50.00	-18.60	-10.14

Power Line Measured : Neutral

Freq. (MHz)	Correct. Factor (dB)	Reading Value (dB $\mu$ V)		Emission Level (dB $\mu$ V)		Limit (dB $\mu$ V)		Margin (dB)	
		Q.P.	AV.	Q.P.	AV.	Q.P.	AV.	Q.P.	AV.
0.150	0.30	59.50	31.75	59.80	32.05	66.00	56.00	-6.20	-23.95
0.153	0.30	58.50	30.78	58.80	31.08	65.82	55.82	-7.02	-24.74
0.869	0.19	35.10	33.51	35.29	33.70	56.00	46.00	-20.71	-12.30
9.689	0.23	38.92	33.26	39.15	33.49	60.00	50.00	-20.85	-16.51
9.974	0.23	40.88	36.96	41.11	37.19	60.00	50.00	-18.89	-12.81
19.100	0.28	43.46	41.96	43.74	42.24	60.00	50.00	-16.26	-7.76

### NOTE :

1. Measurement uncertainty is +/-1.32dB
2. Emission level = Reading valus + Correction factor
3. Correction Factor = Cable loss + Insertion loss of LISN
4. Margin value = Emission level - Limit
5. The emission of other frequencies were very low against the limit.
6. "-": The Quasi-peak reading value also meets average limit and measurement with the average detector is unnecessary.





## 5. RADIATED EMISSION TEST

### 5.1 RADIATED EMISSION LIMIT

CISPR 22:2003 limits of radiated emission measurement for frequency below 1000 MHz

FREQUENCY (MHz)	Class A (at 10m)	Class B (at 10m)
	dB $\mu$ V/m	dB $\mu$ V/m
30 – 230	40	30
230 - 1000	47	37

**NOTE:**

1. The lower limit shall apply at the transition frequencies.
2. Emission level (dB $\mu$ V/m) = 20 log Emission level ( $\mu$ V/m).

### 5.2 TEST EQUIPMENT

The following test equipment was used during the radiated emission test:

EQUIPMENT/ FACILITIES	SPECIFICATIONS	MANUFACTURER	MODEL#/ SERIAL#	DUE DATE OF CAL. & CAL. CENTER
EMI TEST RECEIVER	20 kHz TO 1 GHz	ROHDE & SCHWARZ	ESCS30/ 830245/012	OCT. 2005 ETC
BI-LOG ANTENNA	25 MHz TO 2 GHz	EMCO	3143/ 9509-1141	SEP. 2005 SRT
OATS	3 – 10 M MEASUREMENT	SRT	SRT-1	DEC. 2005 SRT
COAXIAL CABLE	25M	SUNCITY	J400/ 25M	AUG. 2005 SRT
FILTER	2 LINE, 30A	FIL.COIL	FC-943/ 869	N/A
FREQUENCY CONVERTER	N/A	APC	AFC-2KBB/ F100030031	AUG. 2005 SRT

**NOTE:**

1. The calibration interval of the above test equipment is one year and the calibrations are traceable to NML/ROC and NIST/USA.
2. The Open Area Test Site (SRT-1) is registered by FCC with No. 90957 and VCCI with No. R-1081.
3. The Open Area Test Site (SRT-2) is registered by FCC with No. 98458 and VCCI with No. R-1168.



## 5.3 TEST SET-UP

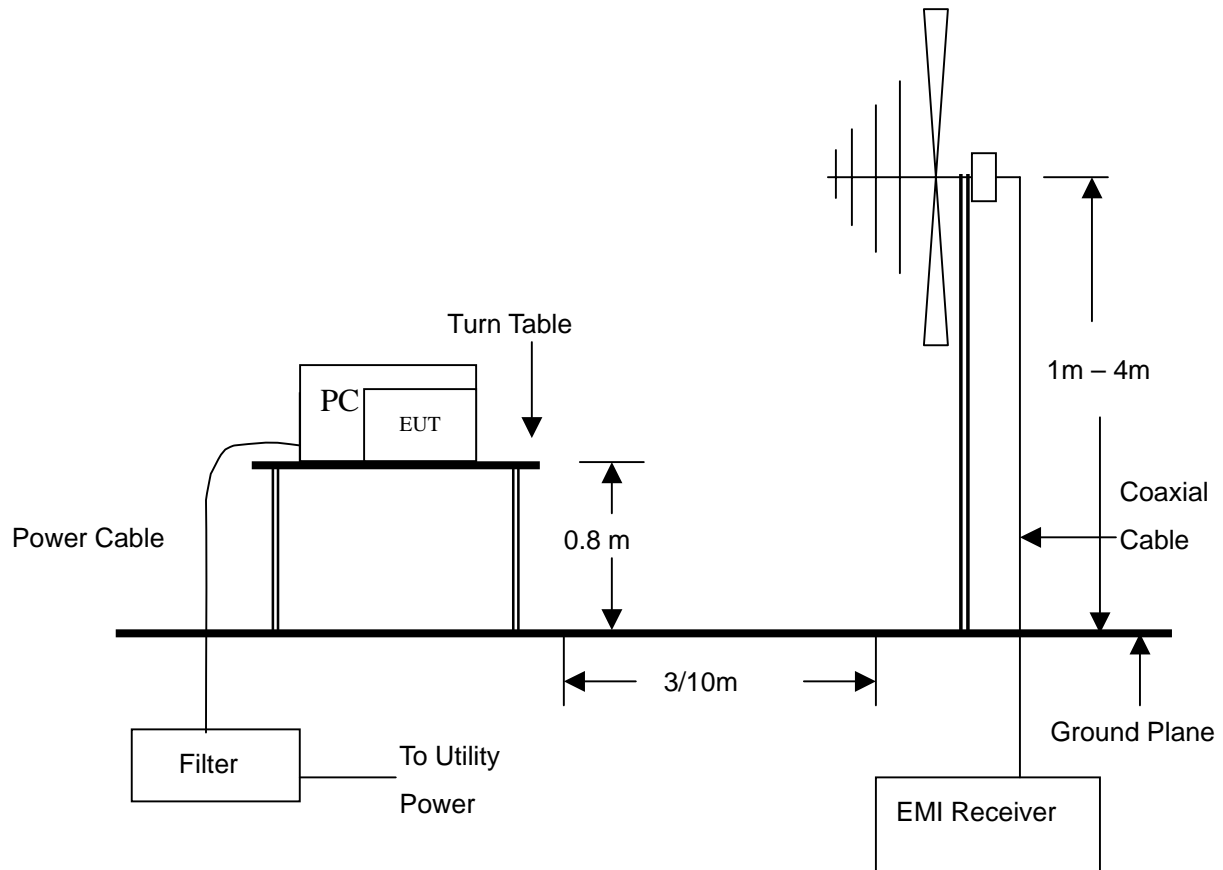

### NOTE :

1. The EUT system was put on a wooden table with 0.8m heights above a ground plane.
2. For the actual test configuration, please refer to the photos of testing.



## 5.4 TEST PROCEDURE

The EUT was tested according to the requirement of ANSI C63.4:2003 and CISPR 22:2003. The measurements were made at an open area test site with 10 meter measurement distance under 1 GHz and with 3m distance above 1GHz. The frequency spectrum measured started from 30 MHz. Under 1 GHz, all readings were quasi-peak values with 120 kHz resolution bandwidth of the test receiver. Above 1 GHz, the measurements were made at an open area test site with 3 meter measurement distance and all readings were peak or average values with 1 MHz resolution bandwidth of the test receiver. The EUT system was operated in all typical methods by users. The cables connected to EUT and support units were moved to find the maximum emission levels for each frequency.

First, Find the margin or higher points at least 6 points by software, then use manual to find the maximum data. The procedure is referred on the test procedure of SRT LAB.

## 5.5 EUT OPERATING CONDITION

Same as section 4.5 of this report.



## 5.6 RADIATED EMISSION TEST RESULT

Temperature:	26°C	Humidity:	66 %RH
Frequency Range:	30 – 1000 MHz	Measured Distance:	10m
Receiver Detector:	Q.P.	Tested Mode:	N/A
Tested By:	Oscar Lu	Tested Date:	July 13, 2005

Antenna Polarization:Horizontal

Frequency (MHz)	Cable Loss (dB)	Antenna Factor (dB/m)	Reading Data (dBμV)	Emission Level (dBμV/m)	Limit (dBμV/m)	Margin (dB)	AZ(°)	EL(m)
749.9760	5.19	21.35	8.4	34.9	37.0	-2.1	269.0	1.50
600.0000	4.60	19.60	9.6	33.8	37.0	-3.2	74.0	3.50
527.9860	4.26	18.65	9.7	32.6	37.0	-4.4	185.0	3.10
431.3980	3.77	16.85	12.4	33.0	37.0	-4.0	266.0	4.00
335.9920	3.20	14.58	17.0	34.8	37.0	-2.2	20.0	2.28
239.9900	2.71	11.67	14.1	28.5	37.0	-8.5	140.0	4.00

Antenna Polarization:Vertical

Frequency (MHz)	Cable Loss (dB)	Antenna Factor (dB/m)	Reading Data (dBμV)	Emission Level (dBμV/m)	Limit (dBμV/m)	Margin (dB)	AZ(°)	EL(m)
199.9400	2.48	9.79	12.3	24.6	30.0	-5.4	180.0	1.00
239.9920	2.71	11.67	13.5	27.9	37.0	-9.1	152.0	1.00
299.6600	3.02	13.67	11.9	28.6	37.0	-8.4	236.0	1.00
335.9900	3.20	14.58	16.2	34.0	37.0	-3.0	15.0	1.00
366.1740	3.38	15.35	10.0	28.7	37.0	-8.3	37.0	1.00
431.2722	3.77	16.85	11.4	32.0	37.0	-5.0	247.0	1.25

### NOTE :

1. Measurement uncertainty is +/-2dB.
2. "\*\*": Measurement does not apply for this frequency.
3. Emission Level = Reading Value + Ant. Factor + Cable Loss.
4. The field strength of other emission frequencies were very low against the limit.



## 6. PHOTOS OF TESTING

- Conducted emission test







**Spectrum Research  
& Testing Lab., Inc.**

No. 101-10, Ling 8,  
Shan-Tong Li, Chung-Li  
City, Taoyuan, Taiwan,  
R.O.C.

# TEST REPORT

Reference No.: A06110803

Report No.: FCBA05062302-02

Page:14 of 15

Date: Nov. 08, 2006

## - Radiated emission test



**Spectrum Research  
& Testing Lab., Inc.**

No. 101-10, Ling 8,  
Shan-Tong Li, Chung-Li  
City, Taoyuan, Taiwan,  
R.O.C.

# TEST REPORT

Reference No.: A06110803  
Report No.: FCBA05062302-02  
Page:15 of 15  
Date: Nov. 08, 2006

## 7. TERMS OF ABBREVIATION

EUT	Equipment Under Test
LISN	Line Impedance Stabilization Network
SRT Lab	Spectrum Research & Testing Laboratory, Inc.
Q.P.	Quasi-peak detection
AV.	Average detection
AZ(°)	Turn table azimuth
EL(m)	Antenna height (meter)
Horiz.	Horizontal direction
Vert.	Vertical direction
Correct.	Correction