



## EMC COMPLIANCE TEST REPORT

for

### KEYBOARD

**Trade Name** : Tai-Hao; Clicker  
**Model Number** : F21 XP SERIES  
F21XP2 / F21XP1 / F21XP3 / F21XP5 / F21XP10 / F21XP7  
**Serial Number** : N/A  
**Report Number** : 02E0683-E  
**Date** : December 5, 2002  
**Regulations** : See below

Standards	Results (Pass/Fail)
EN 55022: 1998	PASS
EN 61000-3-2: 1995+A1: 1998+A2: 1998+A14: 2000	PASS
EN 61000-3-3: 1995	PASS
EN 55024: 1998	PASS
- IEC 61000-4-2: 1995 +A2: 2001	PASS
- IEC 61000-4-3: 1995	PASS
- IEC 61000-4-4: 1995	PASS
- IEC 61000-4-5: 1995	PASS
- IEC 61000-4-6: 1996	PASS
- IEC 61000-4-8: 1993	N/A
- IEC 61000-4-11: 1994	PASS

Prepared for :

**TAIWAN TAI-HAO ENTERPRISE CO., LTD.**  
**6F-5, NO. 155, KEELUNG RD., SEC. 1,**  
**TAIPEI TAIWAN**

Prepared by :

**C&C LABORATORY CO., LTD.**  
#B1, 1st Fl., Universal Center,  
No. 183, Sec. 1, Tatung Rd., Hsi Chin,  
Taipei Hsien, Taiwan, R.O.C.  
TEL: (02)86422071  
FAX: (02)86422256



**This report shall not be reproduced, except in full, without the written approval of  
C&C Laboratory Co., Ltd.**



## EC-Declaration of Conformity

For the following equipment:

KEYBOARD

---

( Product Name )

F21 XP SERIES  
F21XP2 / F21XP1 / F21XP3 / F21XP5 / F21XP10 / F21XP7

---

( Model Designation / Trade name )

TAIWAN TAI-HAO ENTERPRISE CO., LTD.

---

( Manufacturer Name )

6F-5, NO. 155, KEELUNG RD., SEC. 1, TAIPEI TAIWAN

---

(Manufacturer Address)

is herewith confirmed to comply with the requirements set out in the Council Directive on the Approximation of the Laws of the Member States relating to Electromagnetic Compatibility Directive (89/336/EEC, Amended by 92/31/EEC, 93/68/EEC & 98/13/EC), For the evaluation regarding the Electromagnetic Compatibility (89/336/EEC, Amended by 92/31/EEC & 93/68/EEC & 98/13/EC ) the following standards are applied:

EN 55022: 1998

EN 61000-3-2: 1995+A1: 1998+A2: 1998+A14: 2000

EN 61000-3-3: 1995

EN55024: 1998

IEC 61000-4-2: 1995 +A2: 2001, IEC 61000-4-3: 1995, IEC 61000-4-4: 1995

IEC 61000-4-5: 1995, IEC 61000-4-6: 1996, IEC 61000-4-11: 1994

The following manufacturer / importer or authorized representative established within the EUT is responsible for this declaration:

---

( Company Name )

---

( Company Address )

Person responsible for making this declaration:

---

( Name, Surname )

---

( Position / Title )

---

( Place )

( Date )

( Legal Signature )

## TABLE OF CONTENTS

DESCRIPTION	PAGE
VERIFICATION OF COMPLIANCE	5
GENERAL INFORMATION	6
SYSTEM DESCRIPTION	7
PRODUCT INFORMATION	8
SUPPORT EQUIPMENT	9
TEST FACILITY	10
TEST EQUIPMENT	11
<b>SECTION 1 EN 55022(LINE CONDUCTED &amp; RADIATED EMISSION)</b>	14
MEASUREMENT PROCEDURE & LIMIT (LINE CONDUCTED EMISSION TEST)	14
MEASUREMENT PROCEDURE & LIMIT (COMMON MODE CONDUCTED EMISSION MEASUREMENT)	16
MEASUREMENT PROCEDURE & LIMIT (RADIATED EMISSION TEST)	17
BLOCK DIAGRAM OF TEST SETUP	19
SUMMARY DATA	20
<b>SECTION 2 EN61000-3-2 &amp; EN 61000-3-3 (POWER HARMONICS &amp; VOLTAGE FLUCTUATION/FLICKER)</b>	22
BLOCK DIAGRAM OF TEST SETUP	22
RESULT	22
<b>SECTION 3 IEC 61000-4-2 (ELECTROSTATIC DISCHARGE)</b>	33
BLOCK DIAGRAM OF TEST SETUP	33
TEST PROCEDURE	34
PERFORMANCE & RESULT	34
<b>SECTION 4 IEC 61000-4-3 (RADIATED ELECTROMAGNETIC FIELD)</b>	38
BLOCK DIAGRAM OF TEST SETUP	38
TEST PROCEDURE	39
PERFORMANCE & RESULT	40

DESCRIPTION	PAGE
<b>SECTION 5 IEC 61000-4-4 (FAST TRANSIENTS/BURST)</b>	41
BLOCK DIAGRAM OF TEST SETUP	41
TEST PROCEDURE	42
PERFORMANCE & RESULT	42
<b>SECTION 6 IEC 61000-4-5 (SURGE IMMUNITY)</b>	43
BLOCK DIAGRAM OF TEST SETUP	43
TEST PROCEDURE	44
PERFORMANCE & RESULT	44
<b>SECTION 7 IEC 61000-4-6 (CONDUCTED DISTURBANCE, INDUCED BY RADIO-FREQUENCY FIELDS)</b>	45
BLOCK DIAGRAM OF TEST SETUP	45
TEST PROCEDURE	47
PERFORMANCE & RESULT	47
<b>SECTION 8 IEC 61000-4-8 (Power Frequency Magnetic Field))</b>	48
BLOCK DIAGRAM OF TEST SETUP	48
TEST PROCEDURE	49
PERFORMANCE & RESULT	49
<b>SECTION 9 IEC 61000-4-11 (VOLTAGE DIP/INTERRUPTION)</b>	50
BLOCK DIAGRAM OF TEST SETUP	50
TEST PROCEDURE	51
PERFORMANCE & RESULT	51
<b>APPENDIX 1 PHOTOGRAPHS OF TEST SETUP</b>	52
EN 55022 TEST	
EN 61000-3-2 TEST	
EN 61000-3-3 TEST	
IEC 61000-4-2 TEST	
IEC 61000-4-3 TEST	
IEC 61000-4-4 TEST	
IEC 61000-4-5 TEST	
IEC 61000-4-6 TEST	
IEC 61000-4-11 TEST	
<b>APPENDIX 2 PHOTOGRAPHS OF EUT</b>	62
<b>APPENDIX 3 CONDUCTED EMISSION PLOT &amp; RADIATED EMISSION DATA</b>	64

## VERIFICATION OF COMPLIANCE

**Equipment Under Test:** KEYBOARD  
**Trade Name:** Tai-Hao; Clicker  
**Model Number:** F21 XP SERIES  
F21XP2 / F21XP1 / F21XP3 / F21XP5 / F21XP10 / F21XP7  
**Serial Number:** N/A  
**Applicant:** TAIWAN TAI-HAO ENTERPRISE CO., LTD.  
6F-5, NO. 155, KEELUNG RD., SEC. 1,  
TAIPEI TAIWAN  
**Manufacturer:** TAIWAN TAI-HAO ENTERPRISE CO., LTD.  
6F-5, NO. 155, KEELUNG RD., SEC. 1,  
TAIPEI TAIWAN  
**Type of Test:** EMC Directive 89/336/EEC for CE Marking  
**Technical Standards:** EN 55022: 1998  
EN 61000-3-2: 1995+A1: 1998+A2: 1998+A14: 2000  
EN 61000-3-3: 1995  
EN 55024: 1998  
(IEC 61000-4-2: 1995 +A2: 2001, IEC 61000-4-3: 1995  
IEC 61000-4-4: 1995, IEC 61000-4-5: 1995  
IEC 61000-4-6: 1996, IEC 61000-4-11: 1994)  
**File Number:** 02E0683-E  
**Date of test:** December 4, 2002  
**Deviation:** None  
**Condition of Test Sample:** Normal  
**Final Result:** Pass  
**Worst data:** See below

Test Item	Freq.	Measured data	Margin (Mî C)	Remark
Radiated Emission	180.350 (MHz)	26.13 (dBî V/m)	-3.87dB (± 3.3498 dB)	Vertical
Conducted Emission	0.258 (MHz)	50.97 (dBî V)	-10.54dB (± 2.8108 dB)	Neutral

- The negative sign in Margin cell means under the specific limit.
- This test result traceable to national or international standards

The above equipment was tested by C&C Laboratory Co., Ltd. for compliance with the requirements set forth in EMC Directive 89/336/EEC and the Technical Standards mentioned above. This said equipment in the configuration described in this report shows the maximum emission levels emanating from equipment and the level of the immunity endurance of the equipment are within the compliance requirements.

The test results of this report relate only to the tested sample identified in this report.

Approved by Authorized Signatory: \_\_\_\_\_

*Vince Chiang For.*

**James Chan / Manager**

## GENERAL INFORMATION

**Applicant:** TAIWAN TAI-HAO ENTERPRISE CO., LTD.  
6F-5, NO. 155, KEELUNG RD., SEC. 1,  
TAIPEI TAIWAN

**Contact Person:** Kelly Wang

**Manufacturer:** TAIWAN TAI-HAO ENTERPRISE CO., LTD.  
6F-5, NO. 155, KEELUNG RD., SEC. 1,  
TAIPEI TAIWAN

**File Number:** 02E0683-E

**Date of Test:** December 4, 2002

**Equipment Under Test:** KEYBOARD

**Trade Name:** Tai-Hao; Clicker

**Model Number:** F21 XP SERIES  
F21XP2 / F21XP1 / F21XP3 / F21XP5 / F21XP10 / F21XP7

**Serial Number:** N/A

**Type of Test:** EMC Directive 89/336/EEC for CE Marking

**Technical Standards:** EN 55022: 1998  
EN 61000-3-2: 1995+A1: 1998+A2: 1998+A14: 2000  
EN 61000-3-3: 1995  
EN 55024: 1998  
(IEC 61000-4-2: 1995 +A2: 2001, IEC 61000-4-3: 1995  
IEC 61000-4-4: 1995, IEC 61000-4-5: 1995  
IEC 61000-4-6: 1996, IEC 61000-4-11: 1994)

**Frequency Range  
(EN 55022):** 150kHz to 30MHz for Line Conducted Test  
30MHz to 1000MHz for Radiated Emission Test

**Test Site** C&C LABORATORY CO., LTD.  
No. 199, Chung Sheng Road, Hsin Tien City, Taipei  
Taiwan, R. O. C.

## **SYSTEM DESCRIPTION**

### **EUT Test Procedure:**

1. Windows 98 Boots System.
2. Run Emctest.exe & Emitest.exe To Activate All Peripherals And Display “H” Pattern On Monitor Screen.

## PRODUCT INFORMATION

**Housing Type:** Plastic

**EUT Power Rating:** DC 5V from Host PC

**AC power during Test:** 230VAC, 50Hz to Host PC Power Supply

**Power Supply Manufacturer:** Line-on

**Power Supply Model Number:** PS-5141-6G

**AC Power Cord Type:** Unshielded, 1.8m (Detachable)

**EUT I/O Cable Type:** Unshielded, 1.3m (Detachable, with a core)

**OSC/Clock Frequency :** N/A

**Model Differences:**

	Model Name	Differences	Tested (Checked)
<b>Original</b>	F21 XP SERIES	COLOR DIFFERENCE FOR KB KEY CAPS&CASING	<input checked="" type="checkbox"/>
<b>Additional</b>	F21XP2 / F21XP1 / F21XP3 / F21XP5 / F21XP10 / F21XP7		<input type="checkbox"/>

**I/O Port of EUT:**

I/O PORT TYPES	Q'TY	TESTED WITH
1). PS/2 KEYBOARD PORT	1	1

**Note:** N/A



## SUPPORT EQUIPMENT

### Peripherals Devices:

No	Equipment	Model #	Serial #	FCC/ BSMI ID	Trade Name	Data Cable	Power Cord
1.	PS/2 Mouse	M-S34	LZED1303050	DZL211029 BSMI ID:4862A011	LOGITECH	Shielded, 1.9m	N/A
2.	Modem	5JEG4033MKO	L0063CG2D0071 90	5RJTAI-35500-M5-E	TOP- SOLUTION	Shielded, 0.8 m	Unshielded, 1.8m
3.	Host PC	EVOD300	6K1BKF83F2ZD	DoC BSMI ID:3892Q094	COMPAQ	Unshielded, 1.3m with a core	Unshielded, 1.8m
4.	Monitor	RB17NS	N/A	DoC BSMI ID:3902B332	SAMSUNG	Shielded, 1.8m with two cores	Unshielded, 1.8m with a core
5.	Printer	EPSONSTYLU SC20SX	EW4E126644	BSMI ID:3902E004	EPSON	Shielded, 1.8 m	Unshielded, 1.8m

**Note:** All the above equipment/cables were placed in worse case positions to maximize emission signals.

**Grounding:** Grounding was in accordance with the manufacturer's requirements and conditions for the intended use.

## TEST FACILITY

- Location:** No. 199, Chung Sheng Road, Hsin Tien City,  
Taipei, Taiwan, R. O. C.
- Description:** There are two 3/10m open area test sites and one line conducted lab for final test.  
The Open Area Test Sites and the Line Conducted labs are constructed and calibrated to meet the FCC requirements in documents ANSI C63.4: 1992 and CISPR 22/EN 55022 requirements.
- Site Filing:** A site description is on file with the Federal Communications Commission, 7435 Oakland Mills Road, Columbia, MD 21046.  
  
Registration also was made with Voluntary Control Council for Interference (VCCI). Registration No. R-1434/ C-1511
- Site Accreditation:** Accredited by A2LA (Certificate #: 824.01) for EMC.  
  
Also accredited by BSMI for the product category of Information Technology Equipment.
- Instrument Tolerance:** All measuring equipment is in accord with ANSI C63.4 and CISPR 22 requirements that meet industry regulatory agency and accreditation agency requirement.
- Ground Plane:** Two conductive reference ground planes were used during the Line Conducted Emission, one in vertical and the other in horizontal. The dimensions of these ground planes are as below. The vertical ground plane was placed distancing 40 cm to the rear of the wooden test table on where the EUT and the support equipment were placed during test. The horizontal ground plane projected 50 cm beyond the footprint of the EUT system and distanced 80 cm to the wooden test table. For Radiated Emission Test, one horizontal conductive ground plane extended at least 1m beyond the periphery of the EUT and the largest measuring antenna, and covered the entire area between the EUT and the antenna. It has no holes or gaps having longitudinal dimensions larger than one-tenth of a wavelength at the highest frequency of measurement up to 1GHz.

## TEST EQUIPMENT LIST (EMISSION)

**Instrumentation:** The following list contains equipment used at C & C Laboratory Co., Ltd. for testing. The equipment conforms to the CISPR 16-1 / ANSI C63.2-1988 Specifications for Electromagnetic Interference and Field Strength Instrumentation from 9kHz to 1.0 / 2.0 GHz.

**Equipment used during the tests:**

**Open Area Test Site:** #D

EQUIPMENT TYPE	MFR	MODEL NUMBER	SERIAL NUMBER	LAST CAL.	CAL. DUE
EMC ANALYZER	HP	8595EM	3412A00104	03/01/02	02/28/03
AMPLIFIER	HP	8447DB	1644A02328	05/05/02	05/04/03
ANTENNA	SCHWARZBECK	VULB 9160	3104	05/12/02	05/11/03
CABLE	BELDEN	9913	N-TYPE08	04/17/02	04/16/03

**Conducted Area Test Site:** Conducted Room

EQUIPMENT TYPE	MFR	MODEL NUMBER	SERIAL NUMBER	LAST CAL.	CAL. DUE
TEST RECEIVER	R&S	ESHS20	840455/006	03/16/02	03/15/03
LISN	EMCO	3825/2	1842	01/11/02	01/10/03
LISN(EUT)	EMCO	3825/2	1435	01/16/02	01/15/03

The calibrations of the measuring instruments, including any accessories that may effect such calibration, are checked frequently to assure their accuracy. Adjustments are made and correction factors applied in accordance with instructions contained in the manual for the measuring instrument.

## TEST EQUIPMENT LIST

### For Power Harmonic & Voltage Fluctuation/Flicker Measurement:

Manufacturer/Type	Model No.	Serial No.	Last Cal.	Cal. Due
HP / Harmonic & Flicker Tester	6842A	3531A-000142	06/18/2002	06/17/2003

### For ESD test:

Manufacturer/Type	Model No.	Serial No.	Last Cal.	Cal. Due
Schaffner / ESD Simulator	NSG 432	2029	02/06/2002	02/05/2003

### For Radiated Electromagnetic Field immunity Measurement:

Manufacturer/Type	Model No.	Serial No.	Last Cal.	Cal. Due
R&S / Signal Generator	SMY 02	DE13751	01/10/2002	01/09/2003
IFI / "E" Field sensor/ Light Modulator Transmitter	EFS-5	713-0695	06/28/2002	06/27/2003
IFI / Combination Amplifier	SMX100	2067-1196	No Calibration Required	No Calibration Required
IFI / Leveling Pre-Amplifier	LPA-5B	714-0695	No Calibration Required	No Calibration Required
EMCO / Biconilog Antenna	3142	9609-1087	No Calibration Required	No Calibration Required

### For Fast Transients/Burst test:

Manufacturer/Type	Model No.	Serial No.	Last Cal.	Cal. Due
KeyTek Instruments / EFT Generator	E421	9502326	10/01/2002	09/30/2003
KeyTek Instruments / Capacitive Clamp	CCL-4	9503290	No Calibration Required	No Calibration Required

### For Surge Immunity test:

Manufacturer/Type	Model No.	Serial No.	Last Cal.	Cal. Due
KeyTek Instruments/ Surger Generator	E501	9502324	10/01/2002	09/30/2003
Telecom Lines Coupler DECOUPLER KeyTek Instruments	CM-TELCD	0104399	No Calibration Required	No Calibration Required
I/O Signal Line DECOUPLER KeyTek Instruments	CM-I/OCD	0103234	No Calibration Required	No Calibration Required

**For CS test:**

Manufacturer/Type	Model No.	Serial No.	Last Cal.	Cal. Due
R&S / Signal Generator	SMY 02	DE13751	01/10/2002	01/09/2003
IFI / Combination Amplifier	SMX100	2067-1196	No Calibration Required	No Calibration Required
IFI / Leveling Pre-Amplifier	LPA-5B	714-0695	No Calibration Required	No Calibration Required
FISCHER / Power Line Coupling Decoupling Network	FCC-801-M3-16A	99122	11/02/2002	11/01/2003
FISCHER / Bulk Current Injection Probe	F-120-9B	54	11/02/2002	11/01/2003
Narda / High Power Attenuator	769-6	02541	No Calibration Required	No Calibration Required

**For Power Frequency Magnetic Field test :**

Manufacturer/Type	Model No.	Serial No.	Last Cal.	Cal. Due
Haefely / Magic Field Tester	MAG 100.1	081436-02	No Calibration Required	No Calibration Required
Extech Electronics / Frequency Converter	CFC-105	810390	No Calibration Required	No Calibration Required
CHY/ AC/DC Clamp Meter	932C	2K0900285	10/24/2002	10/23/2003

**For Voltage Dips/Short Interruption and Voltage Variation Immunity test:**

Manufacturer/Type	Model No.	Serial No.	Last Cal.	Cal. Due
Haefely / Dips/Inerruption/Variations Tester	PLINE 1610	081568-06	04/25/2002	04/24/2003
FLUKE / 79 Series Ii Multimeter	79-II	66400868	07/02/2002	07/01/2003

## SECTION 1 EN 55022 (LINE CONDUCTED & RADIATED EMISSION)

### MEASUREMENT PROCEDURE (PRELIMINARY LINE CONDUCTED EMISSION TEST)

- 1) The equipment was set up as per the test configuration to simulate typical actual usage per the user's manual. When the EUT is a tabletop system, a wooden table with a height of 0.8 meters is used and is placed on the ground plane as per EN 55022 (see Test Facility for the dimensions of the ground plane used). When the EUT is a floor-standing equipment, it is placed on the ground plane which has a 3-12 mm non-conductive covering to insulate the EUT from the ground plane.
- 2) Support equipment, if needed, was placed as per EN 55022.
- 3) All I/O cables were positioned to simulate typical actual usage as per EN 55022.
- 4) The EUT received DC 5V power through Host PC and Line Impedance Stabilization Network (LISN) which supplied power source of 230VAC/ 50Hz and was grounded to the ground plane.
- 5) All support equipment received power from a second LISN supplying power of 110VAC/60Hz, if any.
- 6) The EUT test program was started. Emissions were measured on each current carrying line of the EUT using a spectrum analyzer / Receiver connected to the LISN powering the EUT. The LISN has two monitoring points: Line 1 (Hot Side) and Line 2 (Neutral Side). Two scans were taken: one with Line 1 connected to Analyzer / Receiver and Line 2 connected to a 50 ohm load; the second scan had Line 1 connected to a 50 ohm load and Line 2 connected to the Analyzer / Receiver.
- 7) Analyzer / Receiver scanned from 150kHz to 30MHz for emissions in each of the test modes.
- 8) During the above scans, the emissions were maximized by cable manipulation.
- 9) The following test mode were scanned during the preliminary test:

**Mode:**

**1        NORMAL MODE**

- 10) After the preliminary scan, we found the following test mode producing the highest emission level.

**Mode:    1.**

Then, the EUT configuration and cable configuration of the above highest emission level were recorded for reference of final testing.

## MEASUREMENT PROCEDURE (FINAL LINE CONDUCTED EMISSION TEST)

- 1) EUT and support equipment was set up on the test bench as per step 10 of the preliminary test.
- 2) A scan was taken on both power lines, Line 1 and Line 2, recording at least the six highest emissions. Emission frequency and amplitude were recorded into a computer in which correction factors were used to calculate the emission level and compare reading to the applicable limit. If EUT emission level was less -2dB to the A.V. limit in Q.P. mode, then the emission signal was re-checked using an A.V. detector.
- 3) The test data of the worst case condition(s) was reported on the Summary Data page.

### Data Sample:

Freq (MHz)	Meter Reading (dBuV)	C.F. (dB)	Corrected Reading (dBuV)	Limits (dBuV)	Margin (dB)	Reading Type (P/Q/A)	Line (L1/L2)
<b>x.xx</b>	<b>x.xx</b>	<b>x.xx</b>	<b>38.38</b>	<b>56.00</b>	<b>-17.62</b>	<b>P</b>	<b>L1</b>

C.F.(Correction Factor)=Insertion Loss + Cable Loss

Corrected Reading = Metering Reading + C.F.

Margin=Corrected Reading - Limits

P=Peak Reading

L1=Hot

Q=Quasi-peak

L2=Neutral

A=Average Reading

Comments: N/A

Calculation example:

$$\text{Margin (dB)} = \text{Corrected Reading (dBuV)} - \text{Limit (dBuV)}$$

## LINE CONDUCTED EMISSION LIMIT (EN 55022)

Frequency	Maximum RF Line Voltage	
	Q.P.	AVERAGE
150kHz-500kHz	66-56dBuV	56-46dBuV
500kHz-5MHz	56dBuV	46dBuV
5MHz-30MHz	60dBuV	50dBuV

**Note:** The lower limit shall apply at the transition frequency.

## MEASUREMENT PROCEDURE (COMMON MODE CONDUCTED EMISSION MEASUREMENT)

- 1) Selecting ISN for unscreened cable or a current probe for screened cable to take measurement.
- 2) The port of the EUT was connected to the remote side support equipment through the ISN/Current Probe and communication in normal condition.
- 3) Making a overall range scan by using the test receiver controlled by controller and record at least six highest emissions for showing in the test report.
- 4) Emission frequency and amplitude were recorded into a computer in which correction factors were used to calculate the emission level and compare reading to the applicable limit.
- 5) In case of measuring on the screened cable, the current limit shall be applied, otherwise the voltage limit should be applied.
- 6) The following test mode(s) were scanned during the preliminary test:  
Mode: N/A (EUT no any Telecommunicate Port)
- 7) After the preliminary scan, we found the following test mode(s) producing the highest emission level and test date of the worst case was reported on the summary data page.  
Mode: N/A

### Data Sample:

Freq (MHz)	Meter Reading (dBuV)	C.F. (dB)	Corrected Reading (dBuV/m)	Limits (dBuV/m)	Margin (dB)	Reading Type (P/Q/A)
<b>x.xx</b>	<b>x.xx</b>	<b>x.xx</b>	<b>59.26</b>	<b>74.00</b>	<b>-14.74</b>	<b>P</b>

C.F.(Correction Factor)=Insertion Loss (9.5dB) + Cable Loss

Corrected Reading = Metering Reading + C.F.

Margin=Corrected Reading - Limits

P=Peak Reading

Q=Quasi-peak

A=Average Reading

Comments: N/A

## COMMON MODE CONDUCTED EMISSION LIMIT AT TELECOMMUNICATION PORTS

<input type="checkbox"/> CE-Mark ( EN 55022:1998 )					
CLASS	Measuring Band	Voltage limit dB(uV)		Current limit dB(uA)	
		Q.P.	AV	Q.P.	AV
B	150kHz-500kHz	84-74	74-64	40-30	30-20
	500kHz-30MHz	74	64	30	20

**Note:** The lower limit shall apply at the transition frequency.



## MEASUREMENT PROCEDURE (PRELIMINARY RADIATED EMISSION TEST)

- 1) The equipment was set up as per the test configuration to simulate typical actual usage per the user's manual. When the EUT is a tabletop system, a wooden turntable with a height of 0.8 meters is used which is placed on the ground plane as per EN 55022 (see Test Facility for the dimensions of the ground plane used). When the EUT is a floor-standing equipment, it is placed on the ground plane which has a 3-12 mm non-conductive covering to insulate the EUT from the ground plane.
- 2) Support equipment, if needed, was placed as per EN 55022.
- 3) All I/O cables were positioned to simulate typical actual usage as per EN 55022.
- 4) The EUT received DC 5V power source from Host PC Power Supply (AC 230V/50Hz) to the outlet socket under the turntable. All support equipment received 110VAC/60Hz power from another socket under the turntable, if any.
- 5) The antenna was placed at 10 meter away from the EUT as stated in EN 55022. The antenna connected to the analyzer via a cable and at times a pre-amplifier would be used.
- 6) The Analyzer / Receiver quickly scanned from 30MHz to 1000MHz. The EUT test program was started. Emissions were scanned and measured rotating the EUT to 360 degrees and positioning the antenna 1 to 4 meters above the ground plane, in both the vertical and the horizontal polarization, to maximize the emission reading level.
- 7) The following test mode were scanned during the preliminary test:

**Mode:**

**1        NORMAL MODE**

- 8) After the preliminary scan, we found the following test mode producing the highest emission level.

**Mode:        1.**

Then, the EUT and cable configuration, antenna position, polarization and turntable position of the above highest emission level were recorded for final testing.

## MEASUREMENT PROCEDURE (FINAL RAIDATED EMISSION TEST)

- 1) EUT and support equipment were set up on the turntable as per step 8 of the preliminary test.
- 2) The Analyzer / Receiver scanned from 30MHz to 1000MHz. Emissions were scanned and measured rotating the EUT to 360 degrees, varying cable placement and positioning the antenna 1 to 4 meters above the ground plane, in both the vertical and the horizontal polarization, to maximize the emission reading level.
- 3) Recorded at least the six highest emissions. Emission frequency, amplitude, antenna position, polarization and turntable position were recorded into a computer in which correction factors were used to calculate the emission level and compare reading to the applicable limit and only Peak reading is presented. If EUT emission level was less-2dB to the limit, then the emission signal was re-checked using a Q.P. detector.
- 4) The test data of the worst case condition(s) was reported on the Summary Data page.

### Data Sample:

Freq (MHz)	Meter Reading (dBuV)	C.F. (dB/m)	Corrected Reading (dBuV/m)	Limits (dBuV/m)	Margin (dB)	Reading Type P/Q/A	Pol. H/V
x.xx	x.xx	x.xx	<b>30.82</b>	<b>37.00</b>	<b>-5.18</b>	<b>P</b>	<b>V</b>

C.F.(Correction Factor)=Antenna Factor + Cable Loss + Attenuator(3/6dB) - Amplifier Gain  
 Corrected Reading = Metering Reading + C.F.  
 Margin=Corrected Reading – Limits

P=Peak Reading                      H=Horizontal Polarization/Antenna  
 Q=Quasi-peak                      V=Vertical Polarization/Antenna  
 A=Average Reading

Comments: N/A

Calculation example:

$$\text{Margin (dB)} = \text{Corrected Reading (dBuV/m)} - \text{Limits (dBuV/m)}$$

$$\text{Corrected Reading (dBuV/m)} = \text{Metering Reading (dBuV)} + \text{Corr Factor (dB/m)}$$

## RADIATED EMISSION LIMIT

Frequency (MHz)	Distance (m)	Maximum Field Strength Limit (dBu V/m/ Q.P.)
30-230	10	30
230-1000	10	37

**Note:** The lower limit shall apply at the transition frequency.

## BLOCK DIAGRAM OF TEST SETUP

### System Diagram of Connections between EUT and Simulators

**EUT: KEYBOARD**

**Trade Name:** Tai-Hao; Clicker

**Model Number:** F21 XP SERIES

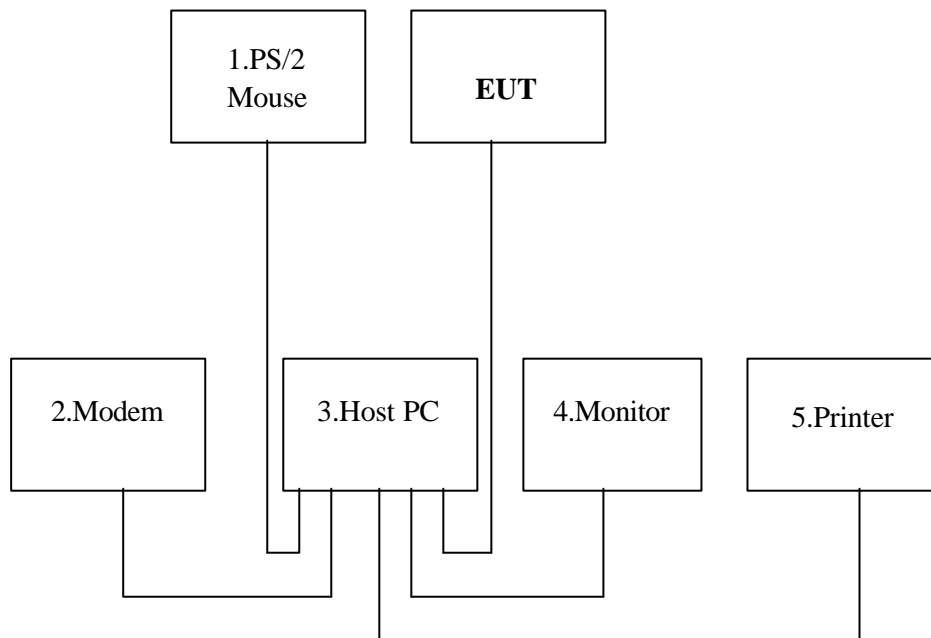

## SUMMARY DATA (LINE CONDUCTED TEST)

**Model Number:** F21 XP SERIES

**Location:** Conducted Room

**Tested by:** Jimmy Chen

**Test Mode:** Mode 1

**Test Results:** Passed

**Temperature:** 30

**Humidity:** 61%RH

(The chart below shows the highest readings taken from the final data)

Frequency Range Investigated (150 kHz TO 30 MHz)							
Freq (MHz)	Meter Reading (dBuV)	C.F. (dB)	Corrected Reading (dBuV)	Limits (dBuV)	Margin (dB)	Reading Type (P/Q/A)	Line (L1/L2)
0.258	46.72	0.04	46.76	61.51	-14.75	P	L1
0.555	40.80	0.07	40.87	56.00	-15.13	P	L1
0.994	41.13	0.10	41.23	56.00	-14.77	P	L2
0.258	50.93	0.04	50.97	61.51	-10.54	P	L2
0.555	42.24	0.07	42.31	56.00	-13.69	P	L2
0.994	42.01	0.10	42.11	56.00	-13.89	P	L2

C.F.(Correction Factor)=Insertion Loss + Cable Loss

Corrected Reading = Metering Reading + C.F.

Margin=Corrected Reading - Limits

P=Peak Reading

L1=Hot

Q=Quasi-peak

L2=Neutral

A=Average Reading

Comments: N/A

## SUMMARY DATA (RADIATED EMISSION TEST)

**Model Number:** F21 XP SERIES

**Location:** Site # D

**Tested by:** Jimmy Chen

**Polar:** Vertical / Horizontal- 10m

**Test Mode:** Mode 1

**Test Results:** Passed

**Temperature:** 25

**Humidity:** 61%RH

(The chart below shows the highest readings taken from the final data)

Frequency Range Investigated (30 MHz TO 1000 MHz)							
Freq (MHz)	Meter Reading (dBUV)	C.F. (dB/m)	Corrected Reading (dBUV/m)	Limits (dBUV/m)	Margin (dB)	Reading Type P/Q/A	Pol. H/V
39.180	34.45	-9.65	24.80	30.00	-5.20	P	V
48.030	34.20	-8.09	26.12	30.00	-3.89	P	V
120.050	32.88	-9.01	23.87	30.00	-6.13	P	V
180.350	34.32	-8.19	26.13	30.00	-3.87	P	V
498.880	31.19	0.89	32.08	37.00	-4.92	P	V
500.350	31.43	0.90	32.33	37.00	-4.67	Q	H

C.F.(Correction Factor)=Antenna Factor + Cable Loss - Amplifier Gain ( + Attenuator 6dB)

Corrected Reading = Metering Reading + C.F.

Margin=Corrected Reading - Limits

P=Peak Reading

H=Horizontal Polarization/Antenna

Q=Quasi-peak

V=Vertical Polarization/Antenna

A=Average Reading

Comments: N/A

## SECTION 2 EN 61000-3-2 & EN 61000-3-3 (POWER HARMONICS & VOLTAGE FLUCTUATION / FLICKER)

### POWER HARMONICS MEASUREMENT

**Port** : AC mains  
**Basic Standard** : EN 61000-3-2 (1995+A1: 1998+A2: 1998 + A14: 2000)  
**Limits** :  Class A,  Class D  
**Temperature** : 21<sup>0</sup>C  
**Humidity** : 58%  
**Test By** : Jimmy Chen

### VOLTAGE FLUCTUATION/FLICKER MEASUREMENT

**Port** : AC mains  
**Basic Standard** : EN 61000-3-3 (1995)  
**Limits** : § 5 of EN 61000-3-3  
**Temperature** : 21<sup>0</sup>C  
**Humidity** : 58%  
**Test By** : Jimmy Chen

### Block Diagram of Test Setup:

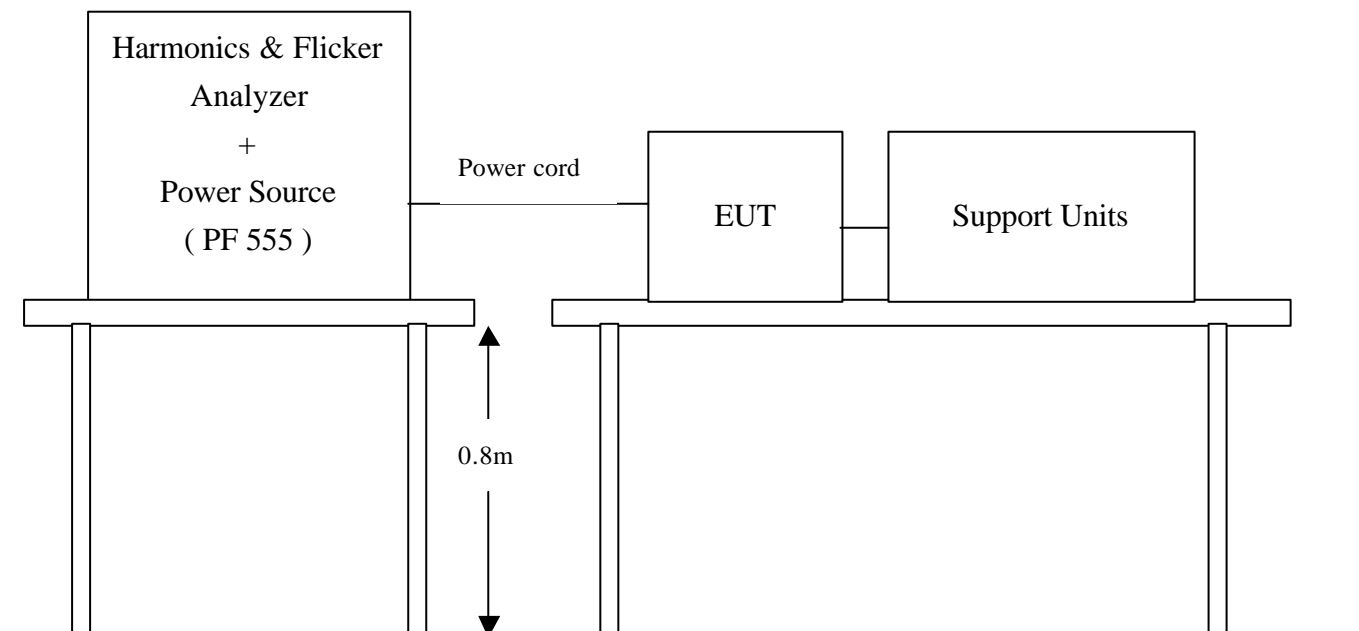

### Result:

Please see the attached test data.

Approved by: Bill Huang 12/5, 02

Signature: Jimmy Chen Date: 12-4-02

Final Test Result: PASS

Settings and Test Conditions Compliant to the Standard: Yes

Test Equipment Used:

Agilent 6842A Harmonic/Flicker Test System with serial number:  
HFTS Software Version: A.05.03  
Date Last Calibrated:

Test Equipment Settings:

-----  
Line Voltage: 230.00 V                      Current Measurement Range: High  
Line Frequency: 50 Hz                      Measurement Window Type: Rectangular  
Device Class: D                              Measurement Delay: 10 seconds  
RMS Current Limit: 13.1 A                      Quasi-stationary Test Duration: 30.00 minutes  
Peak Current Limit: 80.8 A                      Class Determination Pre-test Duration: 10.00 seconds  
Number of Records: 5625

Overrides:

-----  
Test Limit Source (Power Measurements/Statistics): Maximum  
Power Overrides: None  
Test Limit Overrides: None

Pre-test Results for Class Determination:

-----  
Percent in Envelope: 99.0%      Voltage THD Out-of-Specification?: No  
Class D Equipment?: Yes              Fundamental Current: 0.282 A  
  
RMS Voltage: 229.9 V                      RMS Current: 0.4 A                      Real Power: 65.6 W  
Frequency: 50.0 Hz                      Peak Current: 1.0 A                      Apparent Power: 89.2 VA  
Voltage THD: 0.02%                      Current THD: 66.17%                      Power Factor: 0.736  
Maximum Power: 65.6 W                      Mean Power: 62.4 W

Active Power Statistics:

-----  
100th Percentile: 65.6 W                      99th Percentile: 63.8 W                      95th Percentile: 63.8  
90th Percentile: 63.4 W                      50th Percentile: 62.3 W

Total Number of Failures:

-----  
None

Total Number of Errors:

-----  
None

Pre-Test Source Voltage Harmonics Data:

Harmonic Number	Limit (%)	Limit (Volts)	Max (%)	Max (Volts)
Fund.			100.0	229.864
2	0.20	0.460	0.006	0.013
3	0.90	2.069	0.010	0.023
4	0.20	0.460	0.005	0.011
5	0.40	0.919	0.001	0.002
6	0.20	0.460	0.003	0.006
7	0.30	0.690	0.006	0.014
8	0.20	0.460	0.001	0.002
9	0.20	0.460	0.004	0.010
10	0.20	0.460	0.003	0.008
11	0.10	0.230	0.001	0.003
12	0.10	0.230	0.003	0.007
13	0.10	0.230	0.003	0.007
14	0.10	0.230	0.001	0.003
15	0.10	0.230	0.004	0.008
16	0.10	0.230	0.002	0.005
17	0.10	0.230	0.003	0.008
18	0.10	0.230	0.003	0.006
19	0.10	0.230	0.005	0.011
20	0.10	0.230	0.002	0.004
21	0.10	0.230	0.002	0.004
22	0.10	0.230	0.003	0.007
23	0.10	0.230	0.003	0.007
24	0.10	0.230	0.002	0.005
25	0.10	0.230	0.002	0.004
26	0.10	0.230	0.003	0.007
27	0.10	0.230	0.004	0.008
28	0.10	0.230	0.001	0.003
29	0.10	0.230	0.003	0.006
30	0.10	0.230	0.002	0.005
31	0.10	0.230	0.002	0.005
32	0.10	0.230	0.002	0.004
33	0.10	0.230	0.002	0.004
34	0.10	0.230	0.002	0.005
35	0.10	0.230	0.001	0.003
36	0.10	0.230	0.002	0.004
37	0.10	0.230	0.003	0.006
38	0.10	0.230	0.002	0.005
39	0.10	0.230	0.002	0.005
40	0.10	0.230	0.001	0.002



Final Test Data:

Harmonic Number	Standard Limit (A rms)	Maximum Value (A rms)	Maximum Value (% Limit)	Mean Value (A rms)	Mean Value (% Limit)	Standard Deviation (A rms)	Standard Deviation (% Limit)	Pass (P) or Fail (F)
Fund.		0.3420		0.2790		0.0163		
2		0.0025		0.0007		0.0004		
3	2.3000	0.2510	10.9	0.2107	9.2	0.0105	0.5	P
4		0.0013		0.0004		0.0002		
5	1.1400	0.1228	10.8	0.1099	9.6	0.0034	0.3	P
6		0.0006		0.0002		0.0001		
7	0.7700	0.0414	5.4	0.0385	5.0	0.0007	0.1	P
8		0.0005		0.0002		0.0001		
9	0.4000	0.0285	7.1	0.0244	6.1	0.0011	0.3	P
10		0.0004		0.0001		0.0001		
11	0.3300	0.0155	4.7	0.0152	4.6	0.0001	0.0	P
12		0.0003		0.0001		0.0001		
13	0.2100	0.0113	5.4	0.0084	4.0	0.0007	0.3	P
14		0.0004		0.0001		0.0001		
15	0.1500	0.0091	6.1	0.0081	5.4	0.0003	0.2	P
16		0.0004		0.0001		0.0000		
17	0.1324	0.0057	4.3	0.0048	3.6	0.0002	0.1	P
18		0.0003		0.0001		0.0000		
19	0.1184	0.0055	4.6	0.0045	3.8	0.0003	0.2	P
20		0.0003		0.0001		0.0000		
21	0.1071	0.0038	3.5	0.0033	3.1	0.0001	0.1	P
22		0.0002		0.0001		0.0000		
23	0.0978	0.0038	3.9	0.0028	2.8	0.0003	0.3	P
24		0.0003		0.0001		0.0000		
25	0.0900	0.0028	3.1	0.0025	2.8	0.0001	0.1	P
26		0.0002		0.0001		0.0000		
27	0.0833	0.0025	3.0	0.0018	2.2	0.0002	0.2	P
28		0.0003		0.0001		0.0000		
29	0.0776	0.0022	2.8	0.0017	2.2	0.0001	0.1	P
30		0.0002		0.0001		0.0000		
31	0.0726	0.0019	2.6	0.0013	1.8	0.0001	0.2	P
32		0.0003		0.0001		0.0000		
33	0.0682	0.0017	2.6	0.0013	1.9	0.0001	0.2	P
34		0.0002		0.0001		0.0000		
35	0.0643	0.0015	2.3	0.0011	1.6	0.0001	0.1	P
36		0.0002		0.0001		0.0000		
37	0.0608	0.0015	2.5	0.0009	1.5	0.0001	0.2	P
38		0.0002		0.0001		0.0000		
39	0.0577	0.0013	2.3	0.0009	1.5	0.0001	0.2	P
40		0.0002		0.0001		0.0000		

Final Test Statistics:

Harmonic Number	Standard Limit (A rms)	Maximum Value (A rms)	Maximum Value (% Limit)	>50% of Limit (Count)	>75% of Limit (Count)	>90% of Limit (Count)	>95% of Limit (Count)	>100% of Limit (Count)	Pass(P) or Fail(F)
Fund.		0.3420							
2		0.0025		0	0	0	0	0	
3	2.3000	0.2510	10.9	0	0	0	0	0	P
4		0.0013		0	0	0	0	0	
5	1.1400	0.1228	10.8	0	0	0	0	0	P
6		0.0006		0	0	0	0	0	
7	0.7700	0.0414	5.4	0	0	0	0	0	P
8		0.0005		0	0	0	0	0	
9	0.4000	0.0285	7.1	0	0	0	0	0	P
10		0.0004		0	0	0	0	0	
11	0.3300	0.0155	4.7	0	0	0	0	0	P
12		0.0003		0	0	0	0	0	
13	0.2100	0.0113	5.4	0	0	0	0	0	P
14		0.0004		0	0	0	0	0	
15	0.1500	0.0091	6.1	0	0	0	0	0	P
16		0.0004		0	0	0	0	0	
17	0.1324	0.0057	4.3	0	0	0	0	0	P
18		0.0003		0	0	0	0	0	
19	0.1184	0.0055	4.6	0	0	0	0	0	P
20		0.0003		0	0	0	0	0	
21	0.1071	0.0038	3.5	0	0	0	0	0	P
22		0.0002		0	0	0	0	0	
23	0.0978	0.0038	3.9	0	0	0	0	0	P
24		0.0003		0	0	0	0	0	
25	0.0900	0.0028	3.1	0	0	0	0	0	P
26		0.0002		0	0	0	0	0	
27	0.0833	0.0025	3.0	0	0	0	0	0	P
28		0.0003		0	0	0	0	0	
29	0.0776	0.0022	2.8	0	0	0	0	0	P
30		0.0002		0	0	0	0	0	
31	0.0726	0.0019	2.6	0	0	0	0	0	P
32		0.0003		0	0	0	0	0	
33	0.0682	0.0017	2.6	0	0	0	0	0	P
34		0.0002		0	0	0	0	0	
35	0.0643	0.0015	2.3	0	0	0	0	0	P
36		0.0002		0	0	0	0	0	
37	0.0608	0.0015	2.5	0	0	0	0	0	P
38		0.0002		0	0	0	0	0	
39	0.0577	0.0013	2.3	0	0	0	0	0	P
40		0.0002		0	0	0	0	0	

Remarks

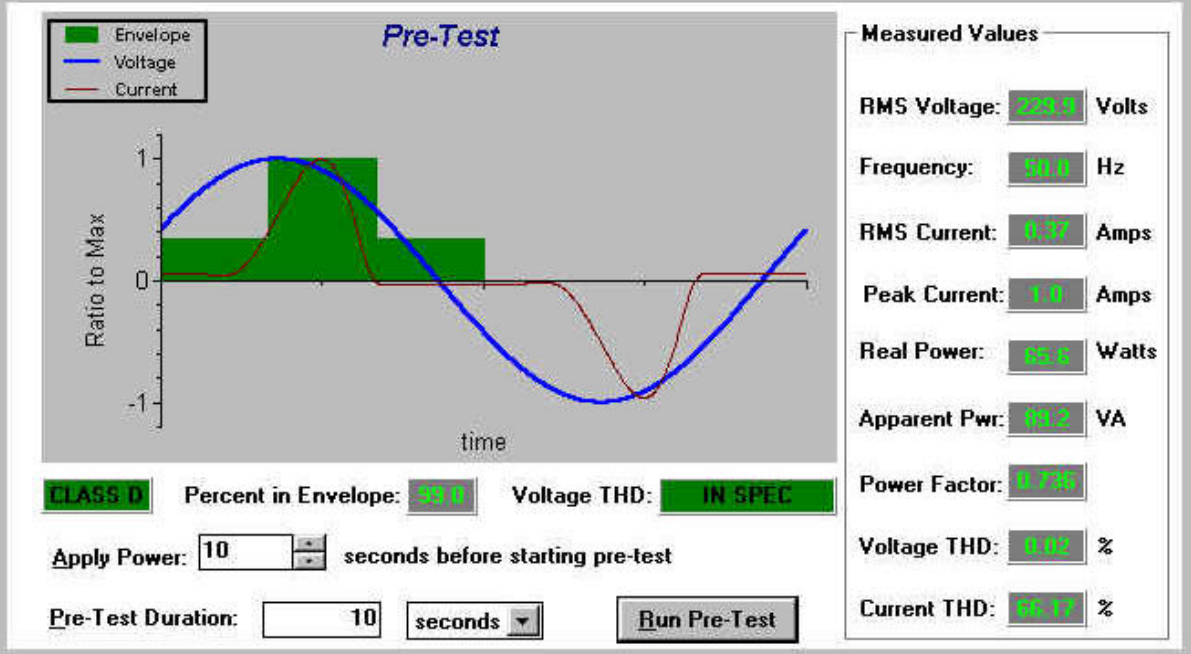

Fixed Span 0:00:30:00.00 Cursor: 0:00:30:00.00 Search Parameters... Reset Max.

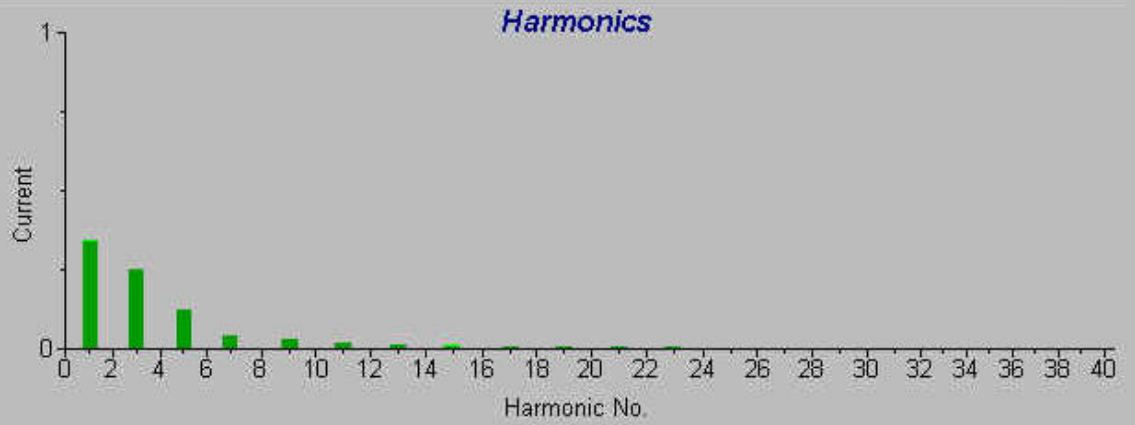

Approved by: Bill Huang 12/5, 02

Signature: Jimmy Chen Date: 12-4-02

Final Test Result: PASS

Settings and Test Conditions Compliant to the Standard: Yes

Test Equipment Used:

Agilent 6842A Harmonic/Flicker Test System with serial number:  
HFTS Software Version: A.05.03  
Date Last Calibrated:

Test Equipment Settings:

Line Voltage: 230.00 V	Pst Integration Time: 10 minutes
Line Frequency: 50 Hz	Pst Integration Periods: 3
Measurement Delay: 10.0 seconds	Test Duration: 00:30:00
RMS Current Limit: 13.1 A	Peak Current Limit: 80.8 A

Overrides:

Pst/Flt Test Limit Overrides: None  
RMS Test Limit Overrides: None

Equipment Under Test Pre-test Results:

RMS Voltage: 229.8 V	RMS Current: 0.4 A	Real Power: 62.6 W
Frequency: 50.0 Hz	Peak Current: 1.0 A	Apparent Power: 85.4 VA
Voltage THD: 0.02%	Current THD: 66.61%	Power Factor: 0.733

Total Number of Failures:

Pst: 0	Dc: 0
Flt: 0	Dmax: 0
	Dt: 0

Total Number of Errors:

None

Final Test Summary:

```

-----
Dmax: 0.0          Pst: 0.07          P_0.1: 0.01
Dc: 0.0           Plt: 0.07          P_1s: 0.01
Dt: 0.00          Flt Threshold: 0.65         P_3s: 0.01
                                          P_10s: 0.01
                                          P_50s: 0.01
  
```

Final Test Data by Integration Period:

Number of Integration Periods: 3

Integration Periods	Pst (P.U.)	P_0.1 (P.U.)	P_1.0s (P.U.)	P_3.0s (P.U.)	P_10s (P.U.)	P_50s (P.U.)	Dc (%)	Dmax (%)	Dt (seconds)	Pass (P) or Fail (F)
1	0.07	0.01	0.01	0.01	0.01	0.01	-----	-----	-----	N/A
2	0.07	0.01	0.01	0.01	0.01	0.01	-----	-----	-----	N/A
3	0.07	0.01	0.01	0.01	0.01	0.01	-----	-----	-----	N/A

Remarks

-----

Fixed Span 0:00:30:00.00 Cursor: 0:00:30:00.00 Search Parameters... Reset Max

*Pst Histogram*

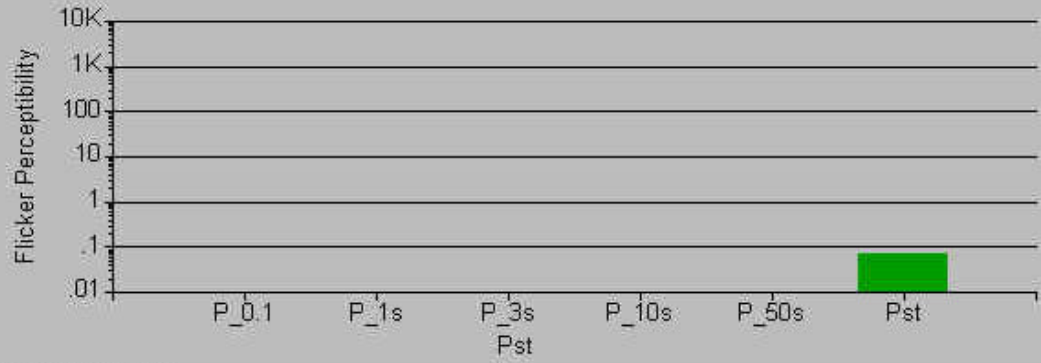

**RMS Measurements**

Dmax  %

Dc  %

Dt  seconds

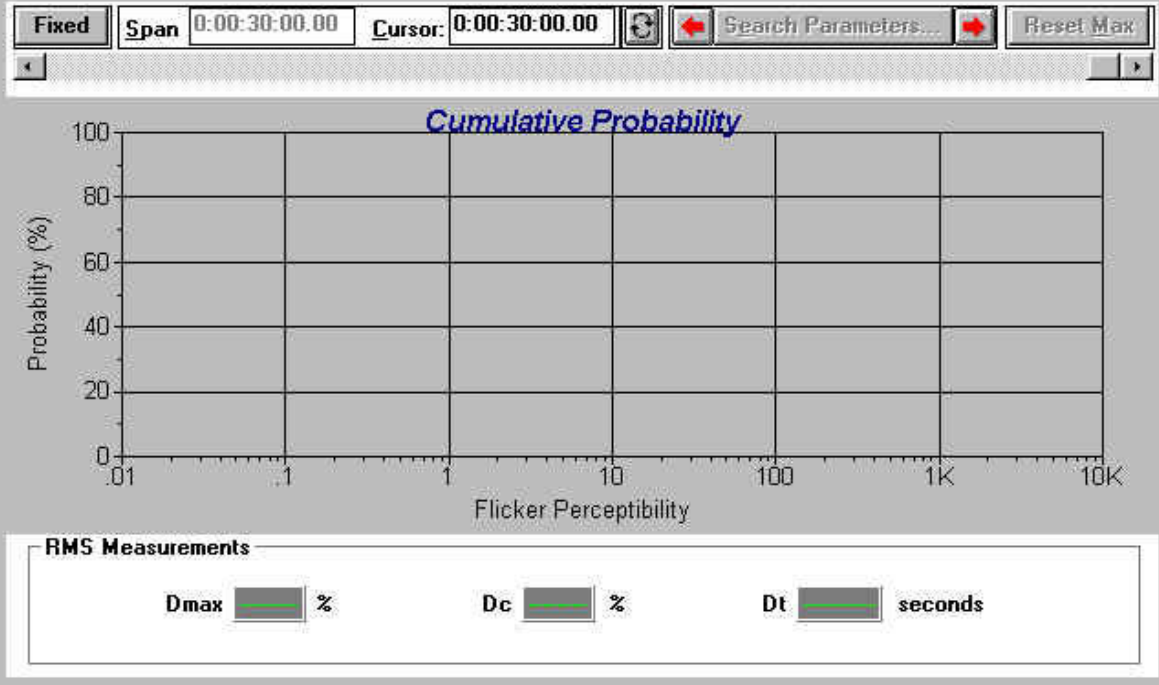



## SECTION 3 IEC 61000-4-2 (ELECTROSTATIC DISCHARGE)

### ELECTROSTATIC DISCHARGE (ESD) IMMUNITY TEST

**Port** : Enclosure  
**Basic Standard** : IEC 61000-4-2  
**Requirements** :  $\pm 8$  kV (Air Discharge)  
                  :  $\pm 4$  kV (Contact Discharge)  
                  :  $\pm 4$  kV (Indirect Discharge)  
**Performance Criteria** : B ( Standard require )  
**Temperature/Humidity** :  $19^{\circ}\text{C}$  /58%  
**Pressure** : 1015 mbar  
**Test By** : Jimmy Chen

#### Block Diagram of Test Setup:

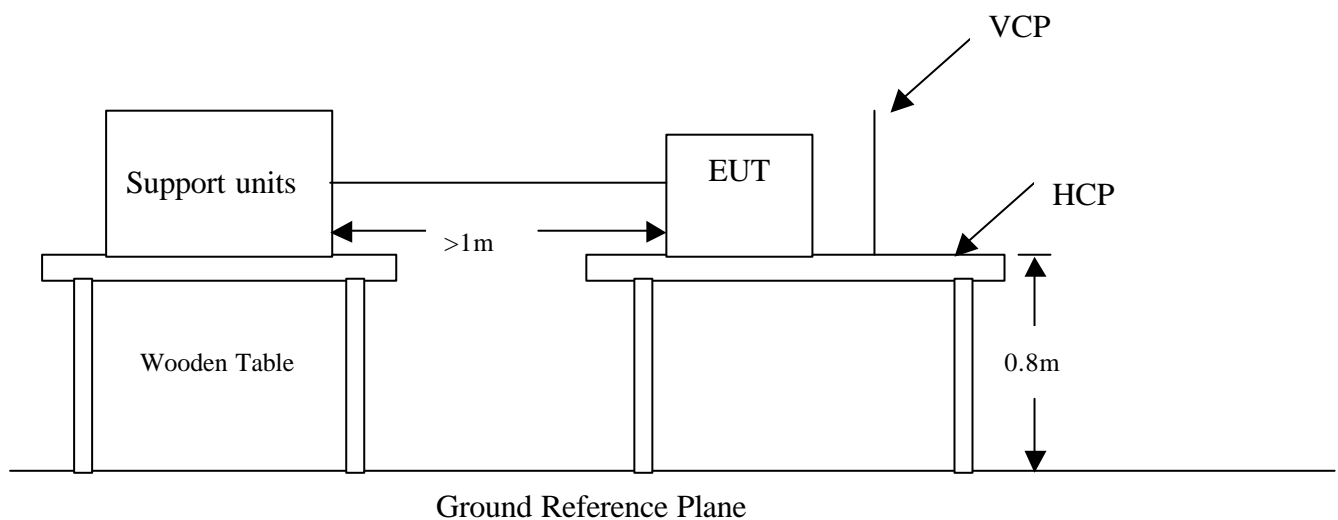

**Test Procedure:**

1. The EUT was located 0.1 m minimum from all side of the HCP.
2. The indirect support units were located 1 m minimum away from the EUT, but direct support unit was/were located at same location as EUT on the HCP and keep at a distance of 10 cm with EUT.
3. A communication test program was loaded and executed in Windows mode.
4. PC sent transmit data to remote side via EUT.
5. As per the requirement of EN 55024; applying direct contact discharge at the sides other than front of EUT at minimum 50 discharges (25 positive and 25 negative) if applicable, can't be applied direct contact discharge side of EUT then the indirect discharge shall be applied. One of the test points shall be subjected to at least 50 indirect discharge (contact) to the front edge of horizontal coupling plane.
6. Other parts of EUT where it is not possible to perform contact discharge then selecting appropriate points of EUT for air discharge, a minimum of 10 single air discharges shall be applied.
7. The application of ESD to the contact of open connectors is not required.
8. Putting a mark on EUT to show tested points. The following test condition was followed during the tests.

**Note:** As per IEC 61000-4-2:2001, with two 470k bleed resistors cable is connected between the EUT and HCP during the test applicable for power ungrounded or battery operating unit only.

The electrostatic discharges were applied as follows:

Amount of Discharges	Voltage	Coupling	Result (Pass/Fail)
Mini 25 /Point	±4kV	Contact Discharge	Pass
Mini 25 /Point	±4kV	Indirect Discharge HCP (Front)	Pass
Mini 25 /Point	±4kV	Indirect Discharge VCP (Back)	Pass
Mini 25 /Point	±4kV	Indirect Discharge VCP (Left)	Pass
Mini 25 /Point	±4kV	Indirect Discharge VCP (Right)	Pass
Mini 10 /Point	±8kV	Air Discharge	Pass

**\*\* The tested points to EUT, please refer to attached page.**

**(Blue arrow mark for contact discharge, red arrow mark for air discharge.)**

**Performance & Result:**

- Criteria A:** The apparatus continues to operate as intended. No degradation of performance or loss of function is allowed below a performance level specified by the manufacturer, when the apparatus is used as intended. In some cases the performance level may be replaced by a permissible loss of performance.
- Criteria B:** The apparatus continues to operate as intended after the test. No degradation of performance or loss of function is allowed below a performance level specified by the manufacturer, when the apparatus is used as intended. In some cases the performance level may be replaced by a permissible loss of performance. During the test, degradation of performance is however allowed.
- Criteria C:** Temporary loss of function is allowed, provided the functions self recoverable or can be restored by the operation of controls.

<input checked="" type="checkbox"/> <b>PASS</b>	<input type="checkbox"/> <b>FAILED</b>
<b>Observation: No any function degraded during the tests.</b>	

*The Tested Points of EUT*

*(Photo 1 of 6)*



*(Photo 2 of 6)*

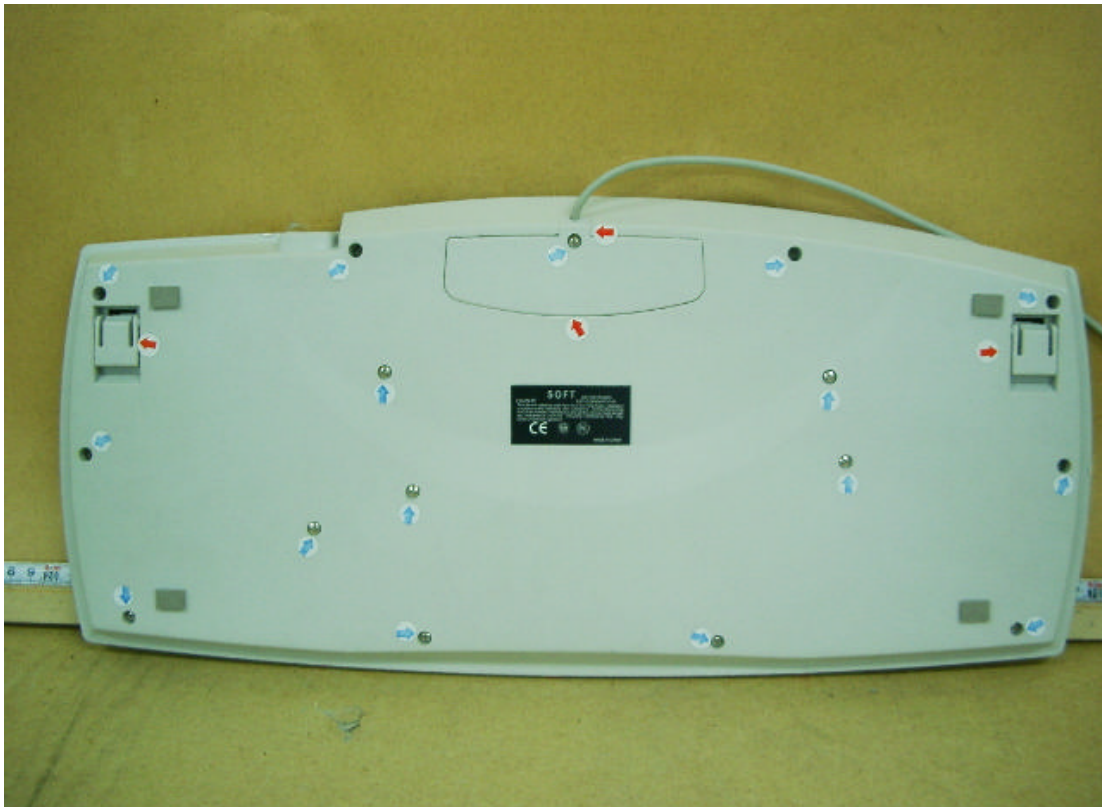

*(Photo 3 of 6)*



*(Photo 4 of 6)*

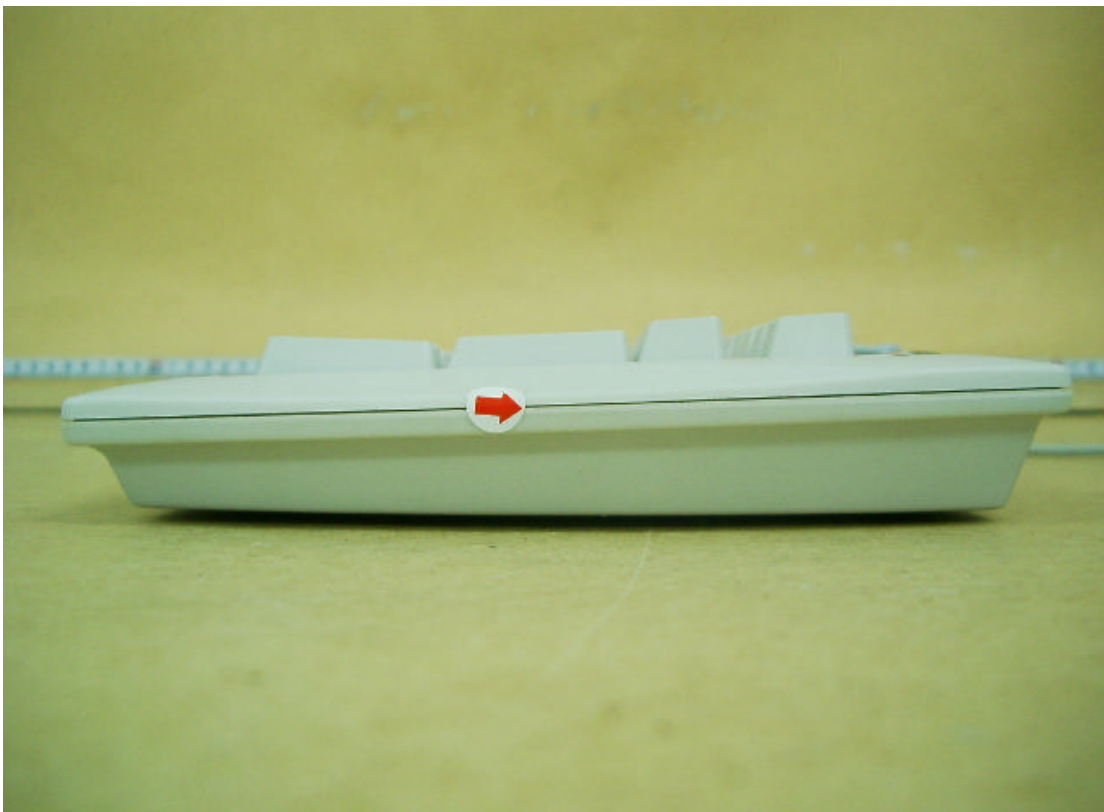



*(Photo 5 of 6)*

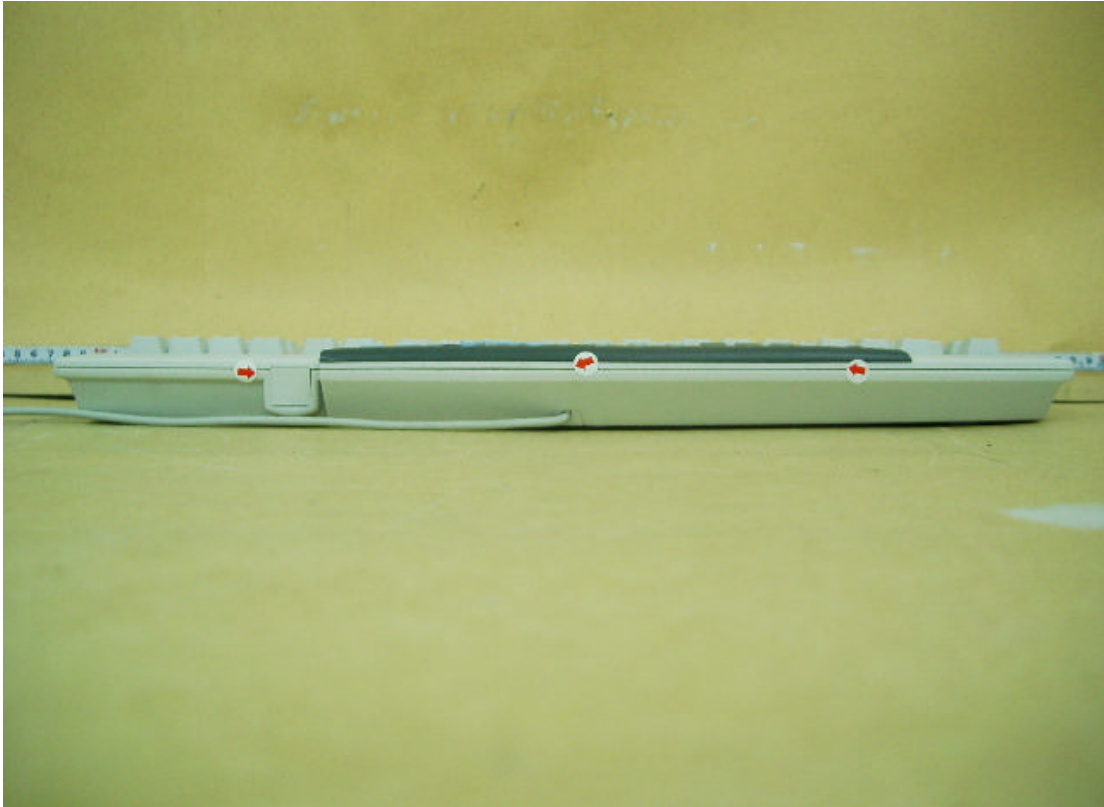

*(Photo 6 of 6)*

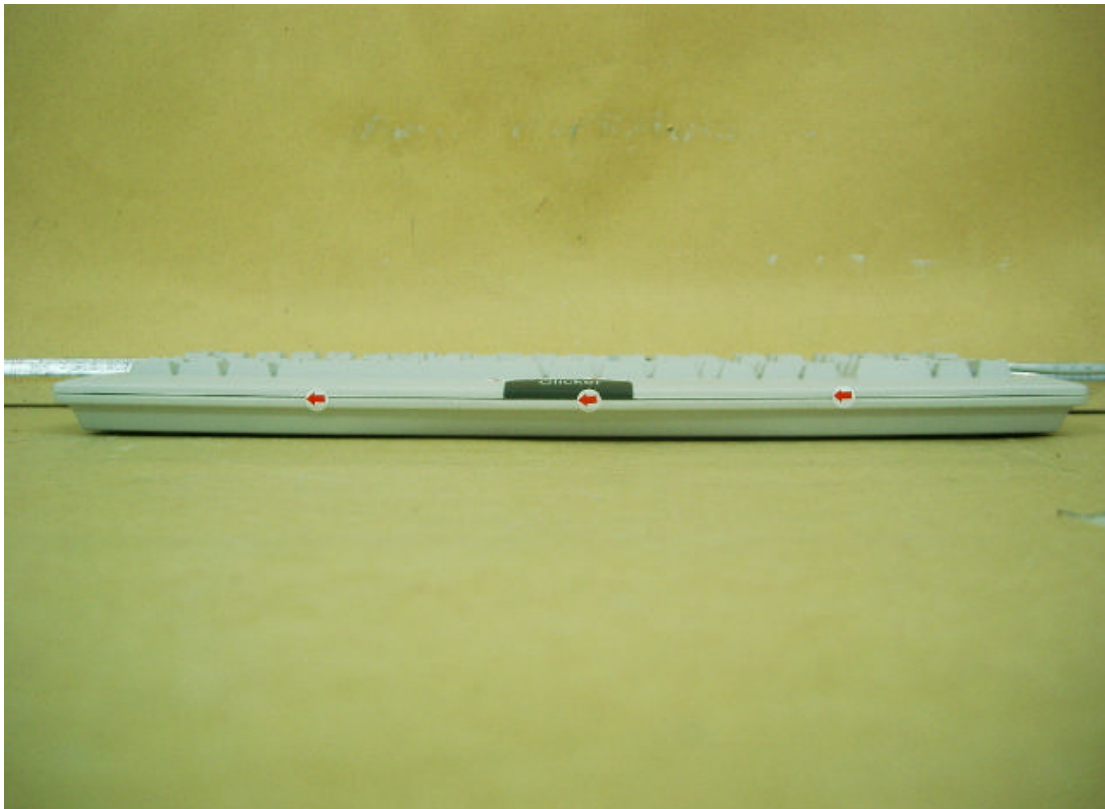

## SECTION 4 IEC 61000-4-3 (RADIATED ELECTROMAGNETIC FIELD )

### RADIATED ELECTROMAGNETIC FIELD IMMUNITY TEST

<b>Port</b>	: Enclosure
<b>Basic Standard</b>	: IEC 61000-4-3
<b>Requirements</b>	: 3 V/m / with 80% AM. 1kHz Modulation
<b>Performance Criteria</b>	: A (Standard require)
<b>Tester</b>	: Jimmy Chen
<b>Temperature</b>	: 23
<b>Humidity</b>	: 72%
<b>Pressure</b>	: 1015 mbar
<b>Note</b>	: The EUT not have acoustic interfaces, the annex A of EN 55024 should not be applied.

#### Block Diagram of Test Setup:

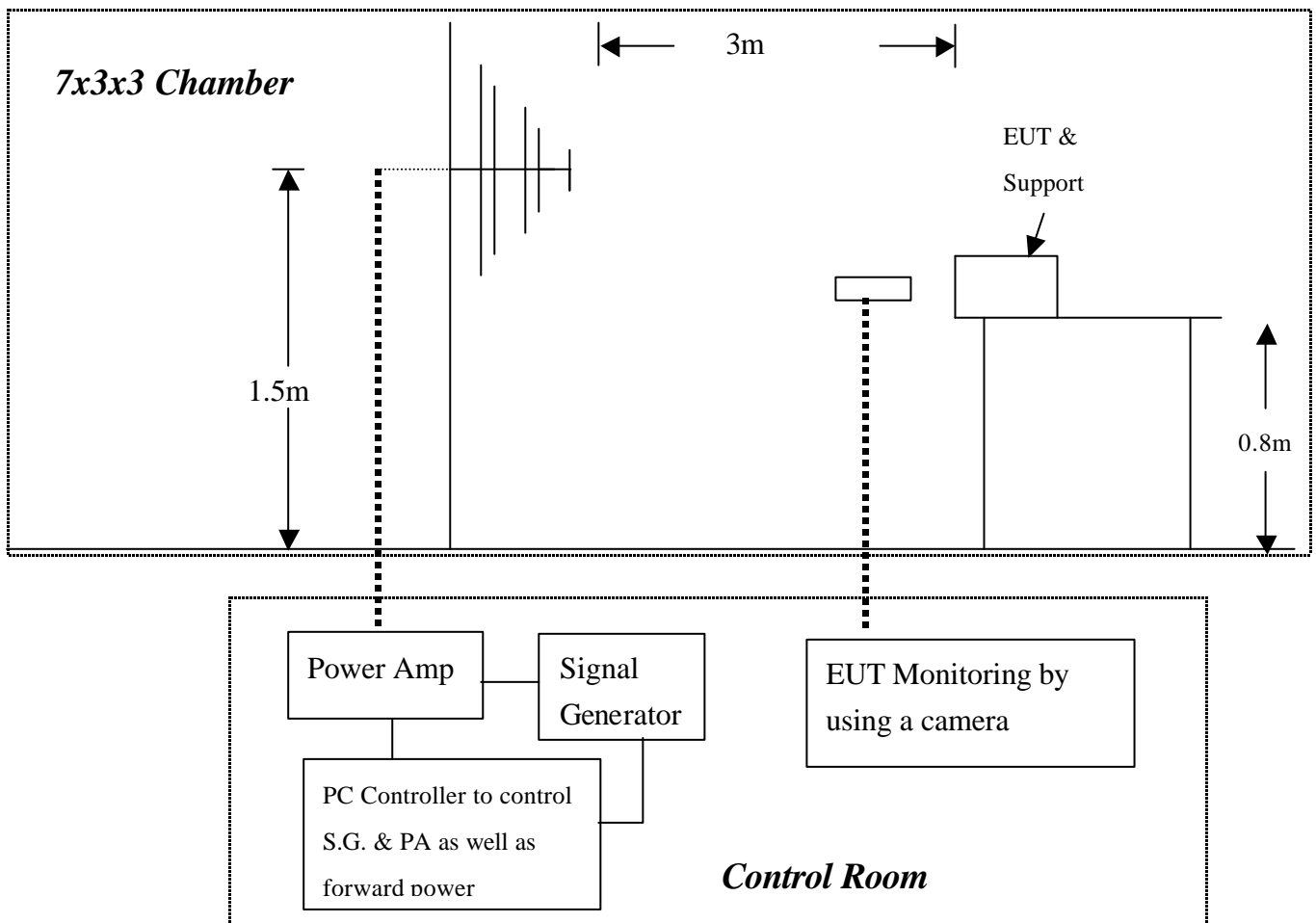

## **Test Procedure:**

1. The EUT and support units were located at the edge of supporting table keep 3 meter away from transmitting antenna, it just the calibrated square area of field uniformity.
2. Adjusting the cables to be exposed to the electromagnetic field as possible.
3. Performing a Radiated Emission Scan in range of 30 to 1000 MHz prior to do RS test and records the more higher emission frequencies for the reference of RS test, due to antenna effectiveness.
4. Adjusting the monitoring camera to monitor the “H” message as clear as possible.
5. Setting the testing parameters of RS test software per IEC 61000-4-3.
6. Referring to the tested data of step 3 to performing the RS test from 80 to 1000 MHz.
7. Recording the test result in following table.
8. Changing the EUT to the other side and repeat step 3 to 6, until 4 sides of EUT were verified.

### **IEC 61000-4-3 Final test conditions:**

Test level : 3V/m  
Steps : 1 % of fundamental  
Dwell Time : 3 sec

Range (MHz)	Field	Modulation	Polarity	Position (°)	Result (Pass/Fail)
80-1000	3V	Yes	H	Front	Pass
80-1000	3V	Yes	V	Front	Pass
80-1000	3V	Yes	H	Right	Pass
80-1000	3V	Yes	V	Right	Pass
80-1000	3V	Yes	H	Back	Pass
80-1000	3V	Yes	V	Back	Pass
80-1000	3V	Yes	H	Left	Pass
80-1000	3V	Yes	V	Left	Pass

**Performance & Result:**

- Criteria A:** The apparatus continues to operate as intended. No degradation of performance or loss of function is allowed below a performance level specified by the manufacturer, when the apparatus is used as intended. In some cases the performance level may be replaced by a permissible loss of performance.
- Criteria B:** The apparatus continues to operate as intended after the test. No degradation of performance or loss of function is allowed below a performance level specified by the manufacturer, when the apparatus is used as intended. In some cases the performance level may be replaced by a permissible loss of performance. During the test, degradation of performance is however allowed.
- Criteria C:** Temporary loss of function is allowed, provided the functions self recoverable or can be restored by the operation of controls.

**PASS**

**FAILED**

**Observation: No any function degraded during the tests.**



## SECTION 5 IEC 61000-4-4 (FAST TRANSIENTS/BURST)

### FAST TRANSIENTS/BURST IMMUNITY TEST

Port	: On Power Lines
Basic Standard	: IEC 61000-4-4
Requirements	: $\pm 1\text{kV}$ for Power Supply Lines
Performance Criteria	: B (Standard require)
Temperature	: $21^{\circ}\text{C}$
Humidity	: 58%
Pressure	: 1015 mbar
Test By	: Jimmy Chen

#### Block Diagram of Test Setup:

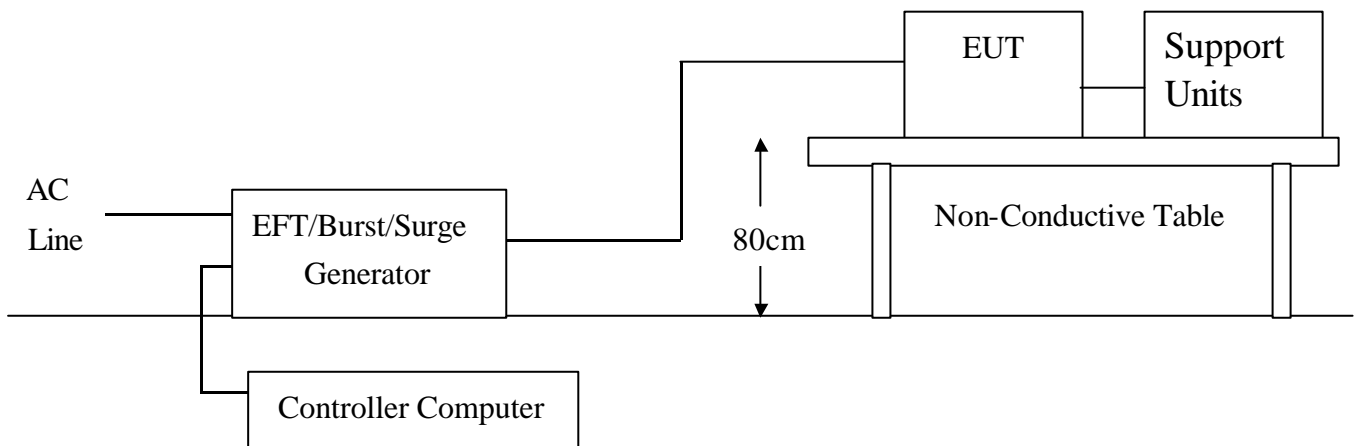

**Test Procedure:**

1. The EUT and support units were located on a wooden table 0.8 m away from ground reference plane.
2. A 1.0 meter long power cord was attached to EUT during the test.
3. The length of communication cable between communication port and clamp was keeping within 1 meter.
4. A test program was loaded and executed in Windows mode.
5. The data was display on the monitor and filling the screens.
6. The test program exercised related support units sequentially.
7. Repeating step 3 to 6 through the test.
8. Recording the test result as shown in following table.

**Test conditions :**

Impulse Frequency: 5kHz  
Tr/Th: 5/50ns  
Burst Duration: 15ms  
Burst Period: 300mS

Inject Line	Voltage kV	Inject Method	Result (Pass/Fail)
L1	+/- 1	Direct	Pass
N	+/- 1	Direct	Pass
PE	+/- 1	Direct	Pass
L1+N	+/- 1	Direct	Pass
L1+PE	+/- 1	Direct	Pass
N+PE	+/- 1	Direct	Pass
L1+N+PE	+/- 1	Direct	Pass

**Performance & Result:**

- Criteria A:** The apparatus continues to operate as intended. No degradation of performance or loss of function is allowed below a performance level specified by the manufacturer, when the apparatus is used as intended. In some cases the performance level may be replaced by a permissible loss of performance.
- Criteria B:** The apparatus continues to operate as intended after the test. No degradation of performance or loss of function is allowed below a performance level specified by the manufacturer, when the apparatus is used as intended. In some cases the performance level may be replaced by a permissible loss of performance. During the test, degradation of performance is however allowed.
- Criteria C:** Temporary loss of function is allowed, provided the functions self recoverable or can be restored by the operation of controls.

<input checked="" type="checkbox"/> <b>PASS</b> <input type="checkbox"/> <b>FAILED</b>
<b>Observation: No any function degraded during the tests.</b>

## SECTION 6 IEC 61000-4-5 ( SURGE IMMUNITY )

### SURGE IMMUNITY TEST

**Port** : Power Cord  
**Basic Standard** : IEC 61000-4-5  
**Requirements** :  $\pm 1\text{kV}$  (Line to Line of Power Port)  
 $\pm 2\text{kV}$  (Line to Earth of Power Port)  
**Performance Criteria** : B (Standard require)  
**Temperature** :  $21^{\circ}\text{C}$   
**Humidity** : 58%  
**Pressure** : 1015 mbar  
**Test By** : Jimmy Chen

### Block Diagram of Test Setup:

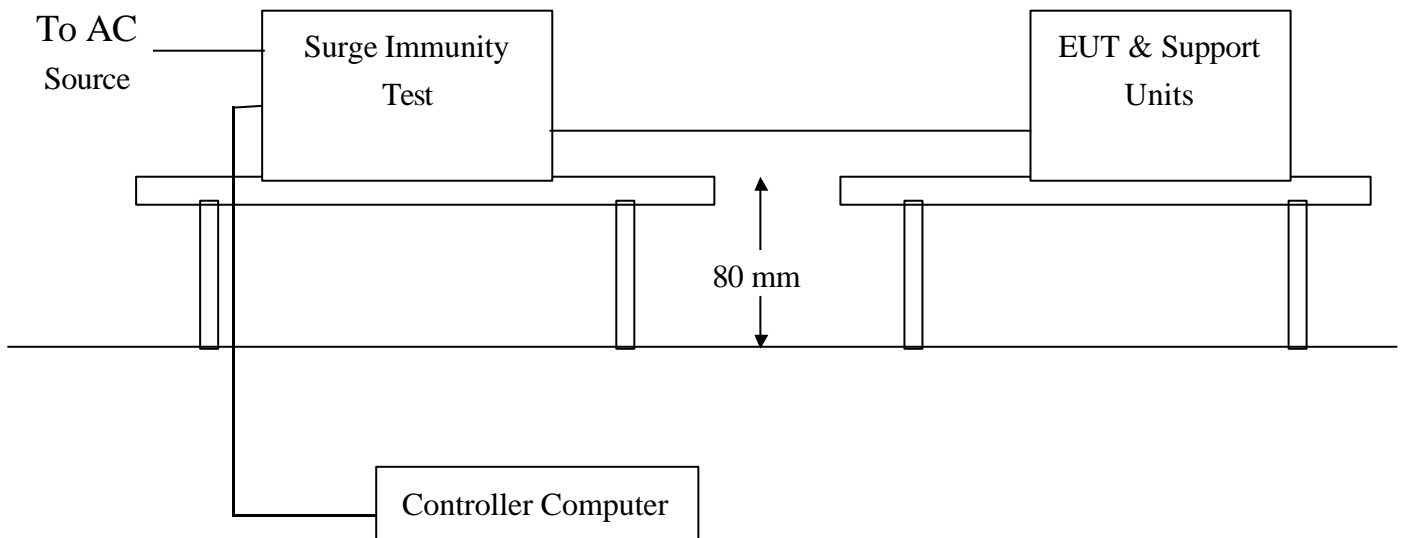

**Test Procedure:**

1. The EUT and support units were located on a wooden table 0.8 m away from ground floor.
2. A test program was loaded and executed in Windows mode.
3. The data was display on the monitor and filling the screens.
4. The test program exercised related support units sequentially.
5. Repeating step 3 to 4 through the test.
6. Recording the test result as shown in following table.

**Test conditions:**

Voltage Waveform : 1.2/50  $\mu$ s  
 Current Waveform : 8/20  $\mu$ s  
 Polarity : Positive/Negative  
 Phase angle : 0<sup>0</sup>, 90<sup>0</sup>, 270<sup>0</sup>  
 Number of Test : 5

Coupling Line	Voltage (kV)	Polarity	Coupling Method	Result (Pass/Fail)
L1-L2、 L1-PE、 L2-PE	1	Positive	Capacitive	Pass
L1-L2、 L1-PE、 L2-PE	1	Negative	Capacitive	Pass
L1-PE、 L2-PE	2	Positive	Capacitive	Pass
L1-PE、 L2-PE	2	Negative	Capacitive	Pass

**Performance & Result:**

- Criteria A:** The apparatus continues to operate as intended. No degradation of performance or loss of function is allowed below a performance level specified by the manufacturer, when the apparatus is used as intended. In some cases the performance level may be replaced by a permissible loss of performance.
- Criteria B:** The apparatus continues to operate as intended after the test. No degradation of performance or loss of function is allowed below a performance level specified by the manufacturer, when the apparatus is used as intended. In some cases the performance level may be replaced by a permissible loss of performance. During the test, degradation of performance is however allowed.
- Criteria C:** Temporary loss of function is allowed, provided the functions self recoverable or can be restored by the operation of controls.

<input checked="" type="checkbox"/> <b>PASS</b> <input type="checkbox"/> <b>FAILED</b>
<b>Observation: No any function degraded during the tests.</b>

## SECTION 7 IEC 61000-4-6 (CONDUCTED DISTURBANCE/INDUCED BY RADIO-FREQUENCY FIELD)

### CONDUCTED DISTURBANCE, INDUCED BY RADIO-FREQUENCY FIELDS

<b>Port</b>	: AC Port
<b>Basic Standard</b>	: IEC 61000-4-6
<b>Requirements</b>	: 3V with 80% AM. Modulation
<b>Injection Method</b>	: CDN-M3
<b>Performance Criteria</b>	: A (Standard require)
<b>Temperature</b>	: 24 <sup>0</sup> C
<b>Humidity</b>	: 72%
<b>Pressure</b>	: 1015 mbar
<b>Test By</b>	: Jimmy Chen

#### Block Diagram of Test Setup:

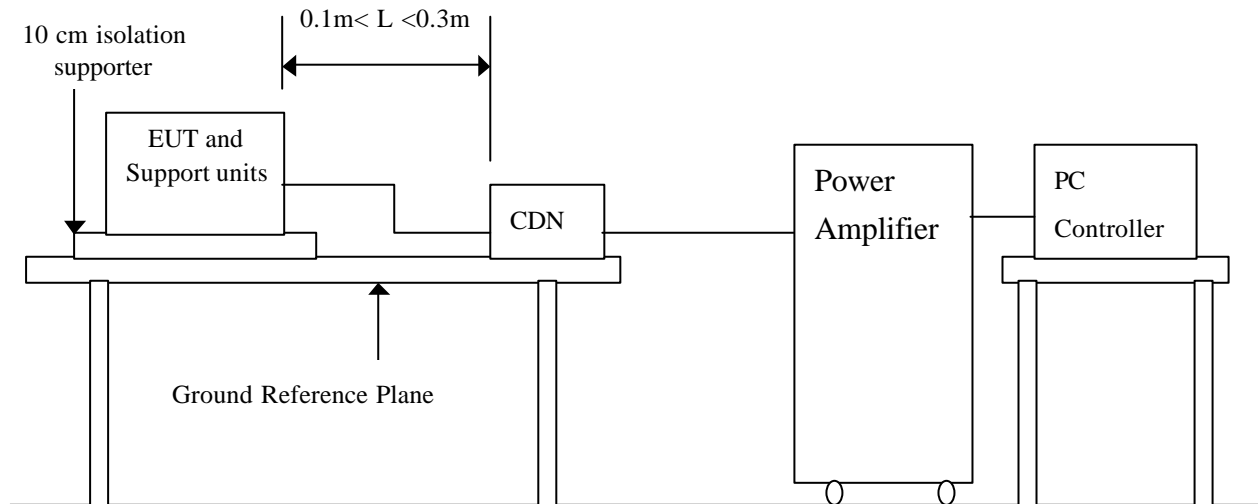

## Top view:

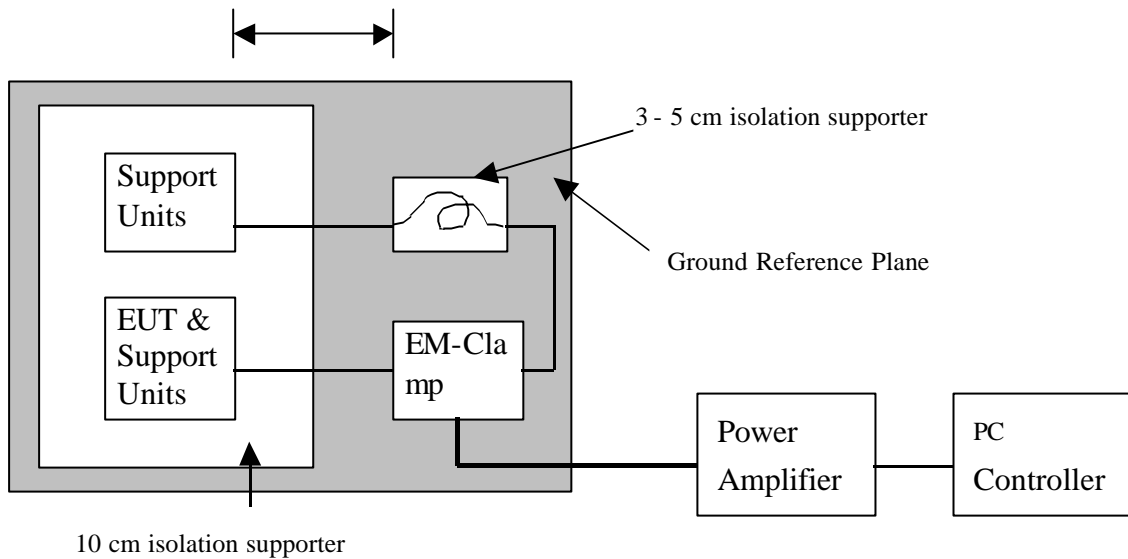

## Test Procedure:

1. The EUT and support units were located at a ground reference plane with the interposition of a 0.1 m thickness insulating support and the CDN was located on GRP directly.
2. Transmit data message were displayed on screen of Monitor.
3. Adjusting the monitoring camera to monitor the transmit data message as clear as possible.
4. Setting the testing parameters of CS test software per IEC 61000-4-6.
5. Recording the test result in following table.

**Test conditions:**

Frequency Range : 0.15MHz-80MHz  
Frequency Step : 1% of fundamental  
Dwell Time : 3 sec

Range (MHz)	Field	Modulation	Result (Pass/Fail)
0.15-80	3V	Yes	Pass

**Performance & Result:**

- Criteria A:** The apparatus continues to operate as intended. No degradation of performance or loss of function is allowed below a performance level specified by the manufacturer, when the apparatus is used as intended. In some cases the performance level may be replaced by a permissible loss of performance.
- Criteria B:** The apparatus continues to operate as intended after the test. No degradation of performance or loss of function is allowed below a performance level specified by the manufacturer, when the apparatus is used as intended. In some cases the performance level may be replaced by a permissible loss of performance. During the test, degradation of performance is however allowed.
- Criteria C:** Temporary loss of function is allowed, provided the functions self-recoverable or can be restored by the operation of controls.

**PASS**       **FAILED**

**Observation: No any function degraded during the tests.**

## SECTION 8 IEC 61000-4-8 (POWER FREQUENCY MAGNETIC FIELD IMMUNITY TEST)

### POWER FREQUENCY MAGNETIC FIELD IMMUNITY TEST

<b>Port</b>	: Enclosure
<b>Basic Standard</b>	: IEC 61000-4-8
<b>Requirements</b>	: 1 A/m
<b>Performance Criteria</b>	: A (Standard Required)
<b>Temperature</b>	: N/A
<b>Humidity</b>	: N/A
<b>Pressure</b>	: N/A
<b>Test By</b>	: N/A

#### Block Diagram of Test Setup:

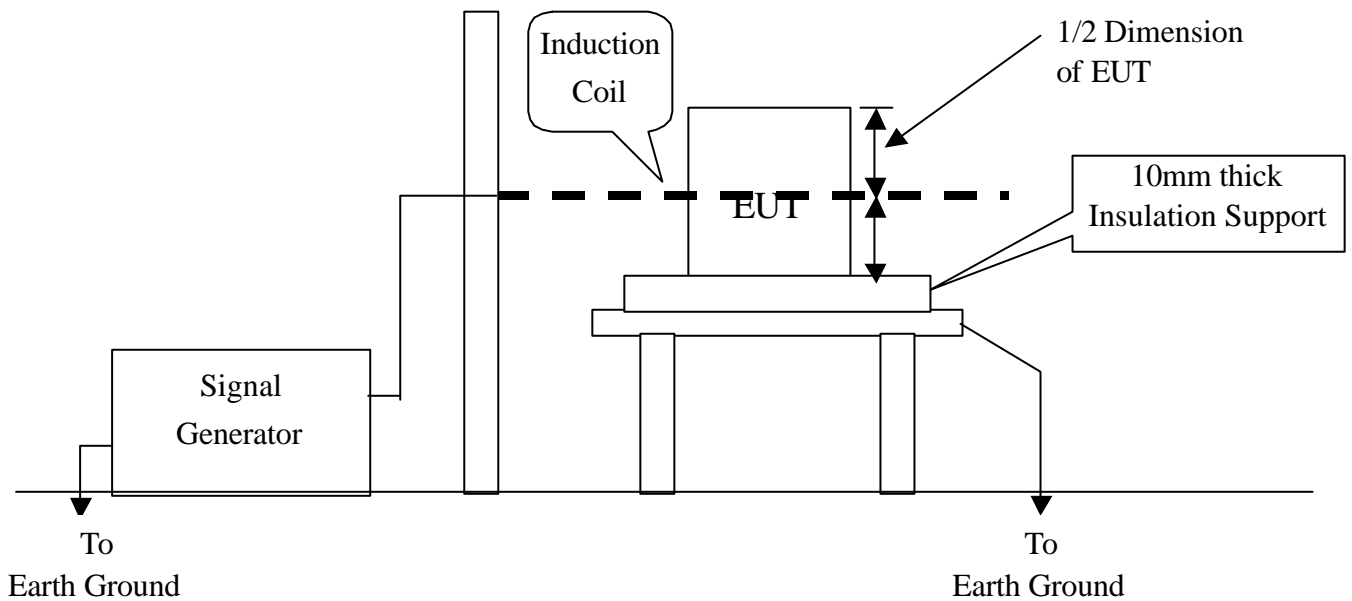



**Test Procedure:**

1. The EUT and support units were located on Ground Reference Plane with the interposition of a 0.1 m thickness insulation support.
2. Putting the induction coil on horizontal direction.( X direction )
3. A test program was loaded and executed in Windows mode.
4. The data was sent to the screen of EUT and filling the screen with upper case of “H” patterns.
5. The test program exercised related support units sequentially.
6. Repeating step 3 to 5 through the test.
7. Recording the test result as shown in following table.
8. Rotating the induction coil by 90<sup>0</sup> ( Y direction ) then repeat step 3 to 7.
9. Rotating the induction coil by 90<sup>0</sup> again ( Z direction ) then repeat step 3 to 7.

\*. Test conditions:

Field Strength: 1A/m  
Power Freq.: 50Hz  
Orientation: X, Y, Z

Orientation	Field	Result (Pass/Fail)	Remark

**\*\*Note:** Not applicable, because no any component can be influenced by power magnetic fields.

**Performance & Result:**

**Criteria A:** The apparatus continues to operate as intended. No degradation of performance or loss of function is allowed below a performance level specified by the manufacturer, when the apparatus is used as intended. In some cases the performance level may be replaced by a permissible loss of performance.

**Criteria B:** The apparatus continues to operate as intended after the test. No degradation of performance or loss of function is allowed below a performance level specified by the manufacturer, when the apparatus is used as intended. In some cases the performance level may be replaced by a permissible loss of performance. During the test, degradation of performance is however allowed.

**Criteria C:** Temporary loss of function is allowed, provided the functions self recoverable or can be restored by the operation of controls.

<input type="checkbox"/> <b>PASS</b> <input type="checkbox"/> <b>FAILED</b>
<b>Observation: N/A (EUT Without any magnetic component)</b>

**SECTION 9 IEC 61000-4-11  
(VOLTAGE DIPS, SHORT INTERRUPTIONS AND VOLTAGE VARIATIONS )**

**VOLTAGE DIPS / SHORT INTERRUPTIONS**

**Port** : AC mains  
**Basic Standard** : IEC 61000-4-11 (1994)  
**Requirement** : PHASE ANGLE 0, 45, 90, 135, 180, 225, 270, 315 degrees

Voltage Dips	Test Level	Reduction	Duration	Performance
	% $U_T$	(%)	( periods )	Criteria
	<5	>95	0.5	B
70	30	25	C	

Voltage Interceptions	Test Level	Reduction	Duration	Performance
	% $U_T$	(%)	( periods )	Criteria
<5	>95	250	C	

**Test Interval** : Min. 10 sec.  
**Temperature** : 21<sup>0</sup>C  
**Humidity** : 58%  
**Pressure** : 1015 mbar  
**Test By** : Jimmy Chen

**Block Diagram of Test Setup:**

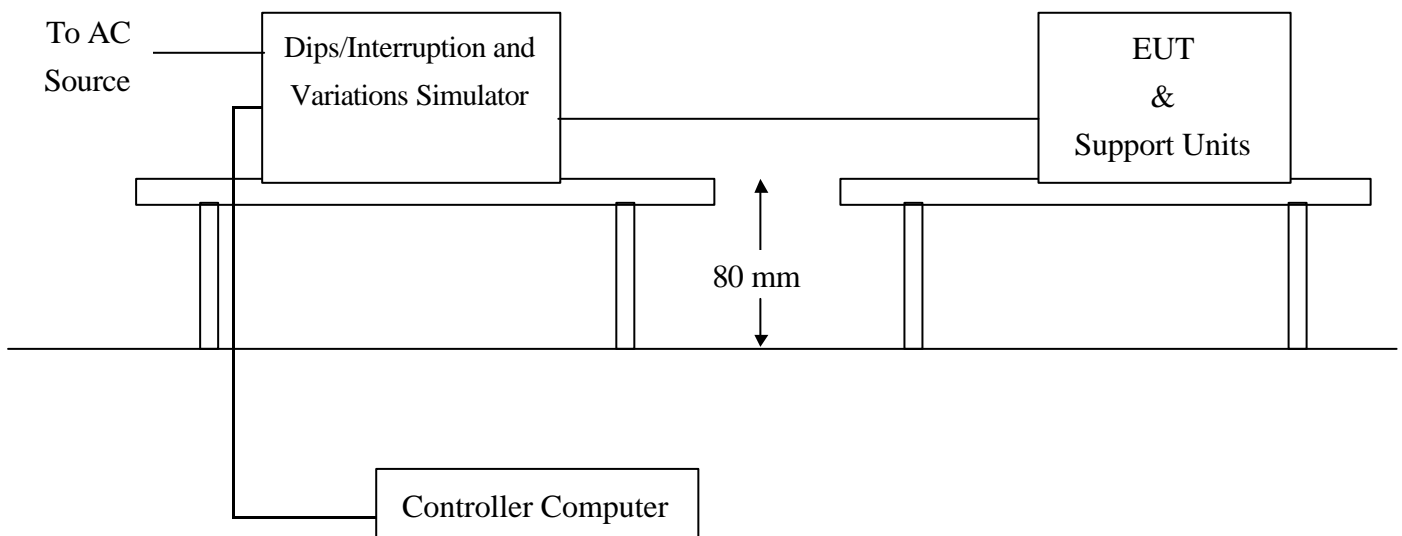

**Test Procedure:**

1. The EUT and support units were located on a wooden table, 0.8 m away from ground floor.
2. A test program was loaded and executed in Windows mode.
3. The data was displayed on the monitor and filling the screens.
4. The test program exercised related support units sequentially.
5. Setting the parameter of test and then Perform the test software of test simulator.
6. Conditions changes to occur at 0 degree crossover point of the voltage waveform.
7. Repeating step 3 to 4 through the test.
8. Recording the test result in the test record form.

**Test conditions:**

The duration with a sequence of three dips/interruptions with interval of 10 s minimum  
( Between each test event )

**Voltage Dips:**

Test Level % U <sub>T</sub>	Reduction (%)	Duration ( periods)	Observation	Meet Performance Criteria
0	100	0.5	Normal	A
70	30	25	Normal	A

**Voltage Interruptions:**

Test Level % U <sub>T</sub>	Reduction (%)	Duration ( periods)	Observation	Meet Performance Criteria
0	100	250	Host PC shut down, but EUT can be auto recovered after Host PC restart.	C

**Performance & Result:**

**Criteria A:** The apparatus continues to operate as intended. No degradation of performance or loss of function is allowed below a performance level specified by the manufacturer, when the apparatus is used as intended. In some cases the performance level may be replaced by a permissible loss of performance.

**Criteria B:** The apparatus continues to operate as intended after the test. No degradation of performance or loss of function is allowed below a performance level specified by the manufacturer, when the apparatus is used as intended. In some cases the performance level may be replaced by a permissible loss of performance. During the test, degradation of performance is however allowed.

**Criteria C:** Temporary loss of function is allowed, provided the functions self recoverable or can be restored by the operation of controls.

<input checked="" type="checkbox"/> <b>PASS</b>	<input type="checkbox"/> <b>FAILED</b>
---	--

## **APPENDIX 1**

### **PHOTOGRAPHS OF TEST SETUP**

### LINE CONDUCTED EMISSION TEST (EN 55022)

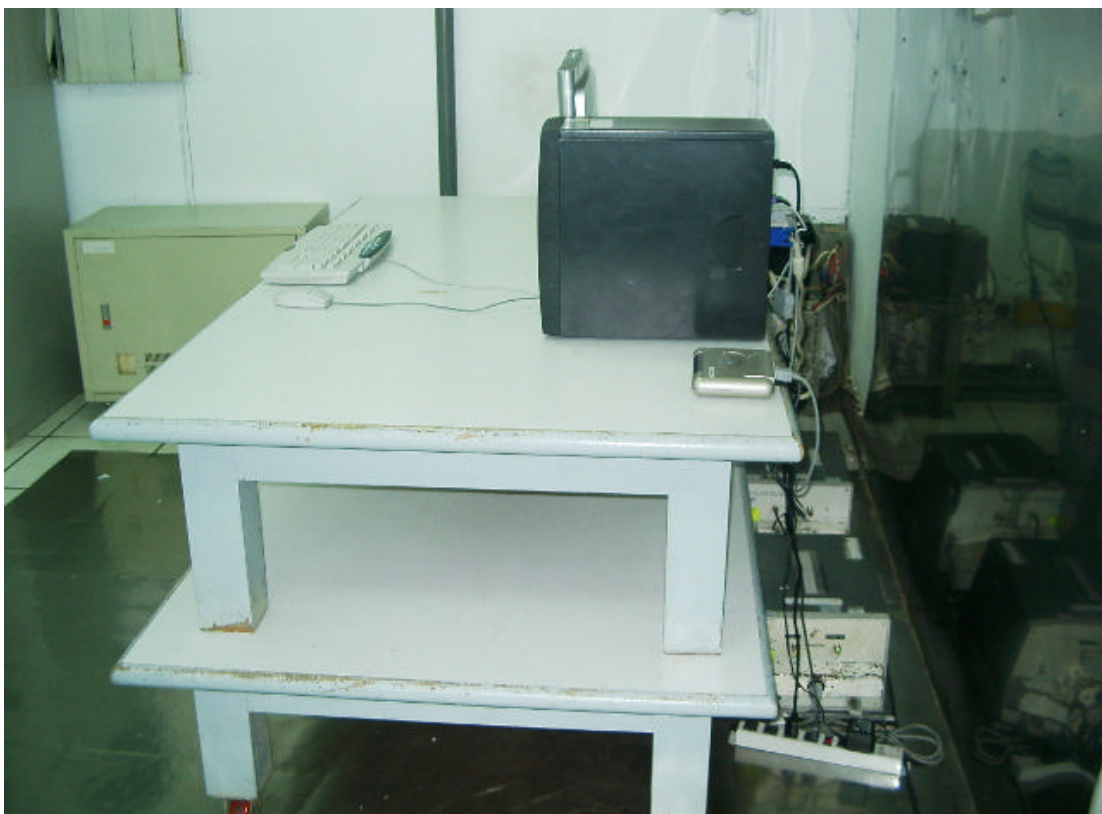

### RADIATED EMISSION TEST (EN 55022)

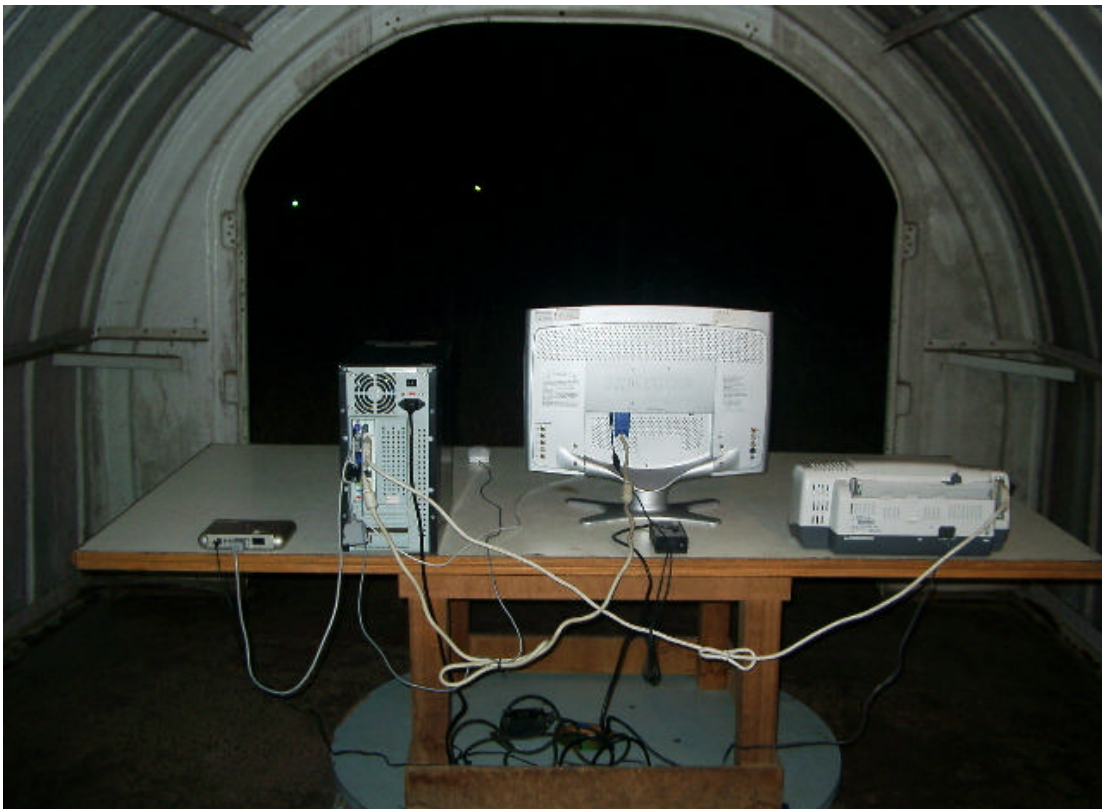



## POWER HARMONIC & VOLTAGE FLUCTUATION / FLICKER TEST (EN 61000-3-2, EN 61000-3-3)



## ELECTROSTATIC DISCHARGE TEST (IEC 61000-4-2)





## RADIATED ELECTROMAGNETIC FIELD (IEC 61000-4-3)

Front View

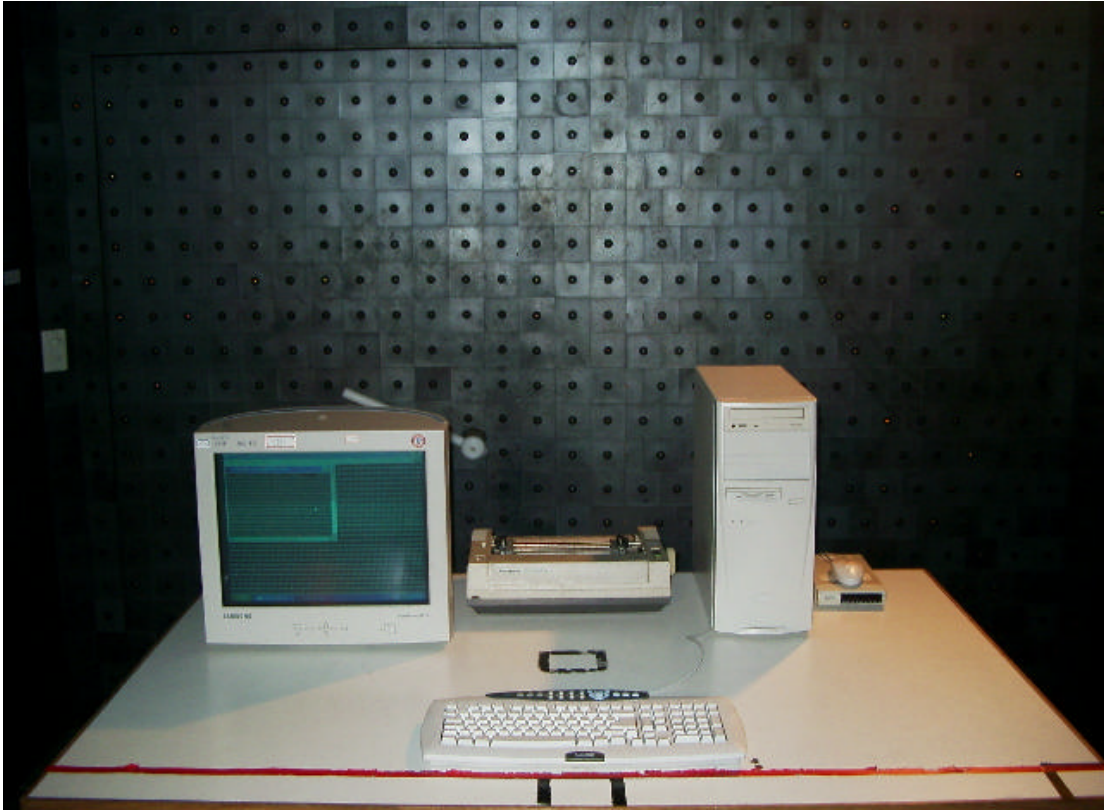

Back View

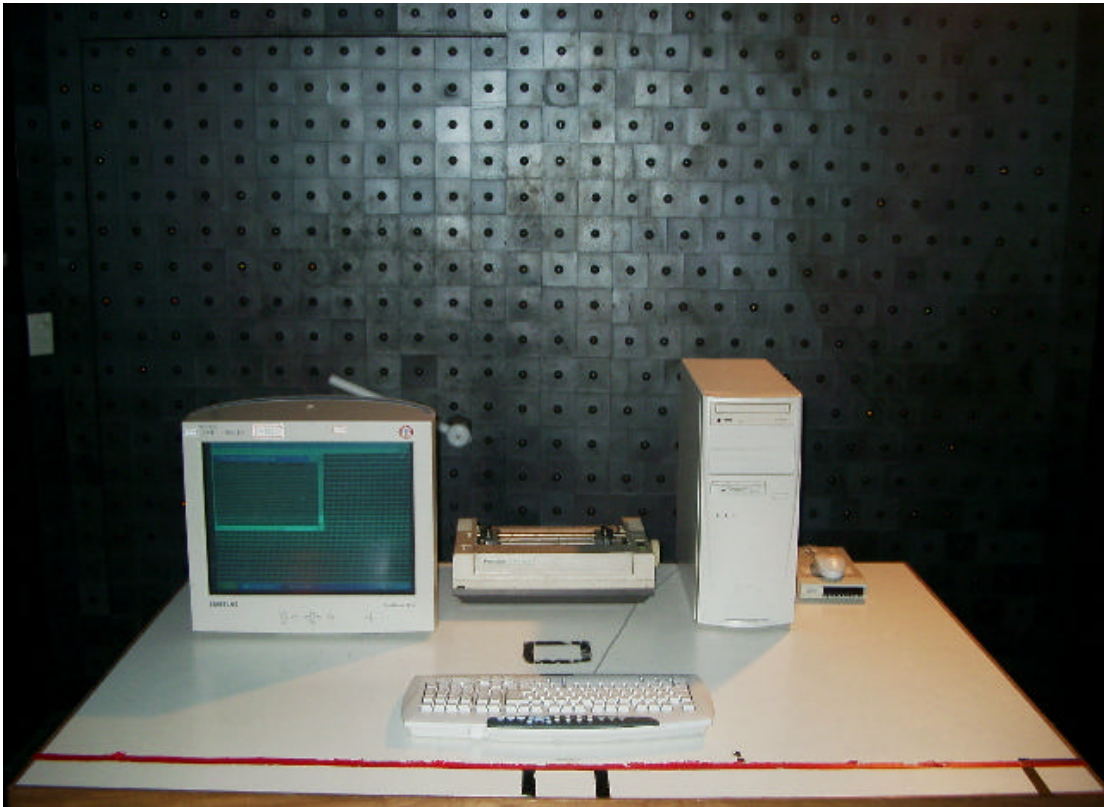

**Left View**

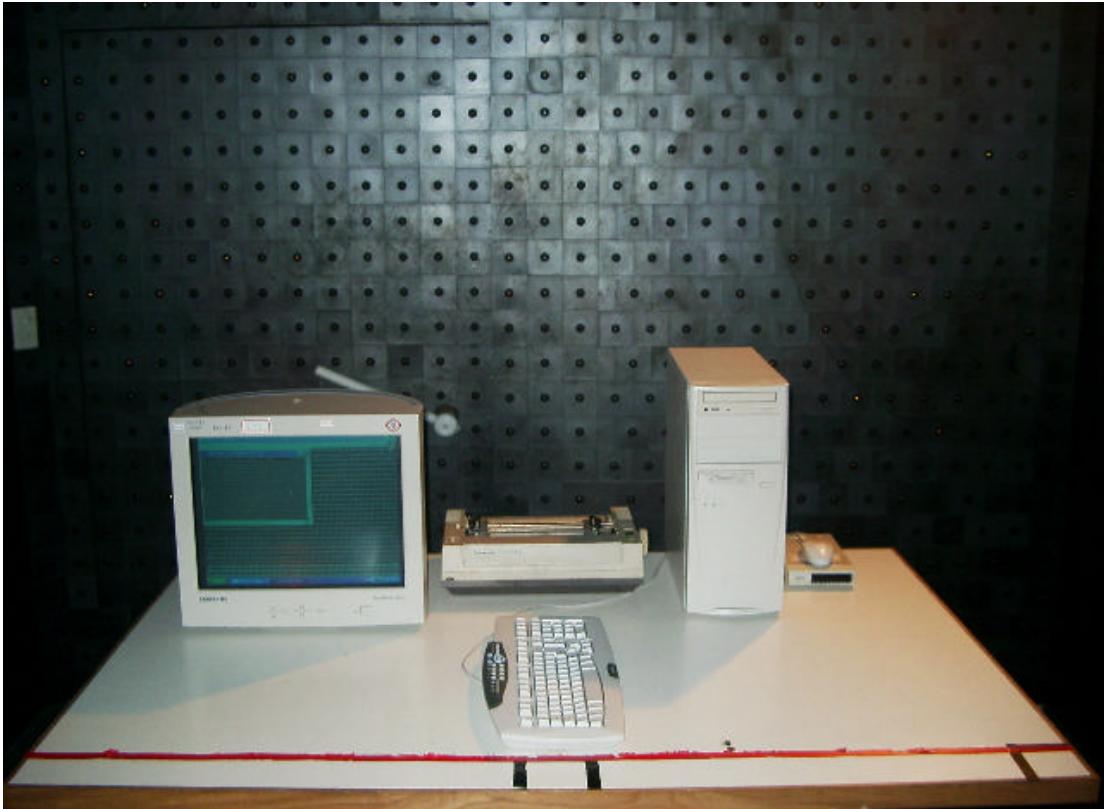

**Right View**

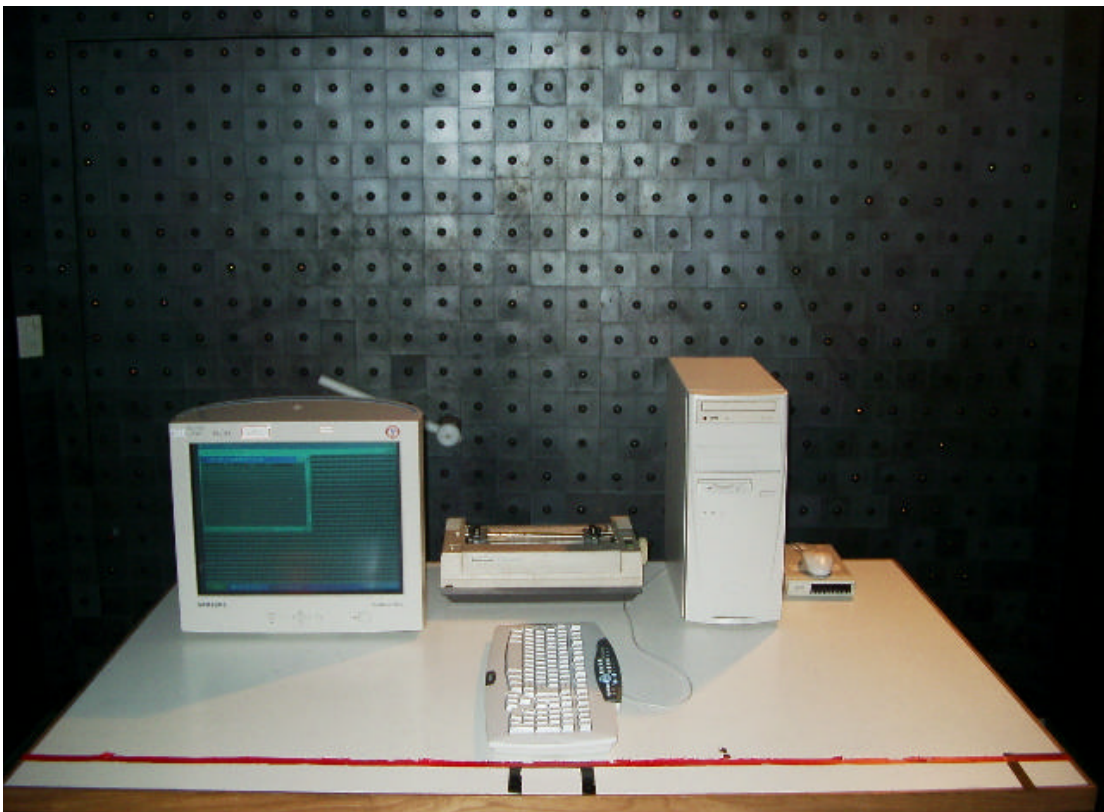



## FAST TRANSIENTS/BURST TEST & SURGE IMMUNITY TEST (IEC 61000-4-4/5)



## CONDUCTED DISTURBANCE, INDUCED BY RADIO-FREQUENCY FIELDS TEST (IEC 61000-4-6)



## VOLTAGE DIPS / INTERRUPTION TEST (IEC 61000-4-11)



## **APPENDIX 2**

### **PHOTOGRAPHS OF EUT**



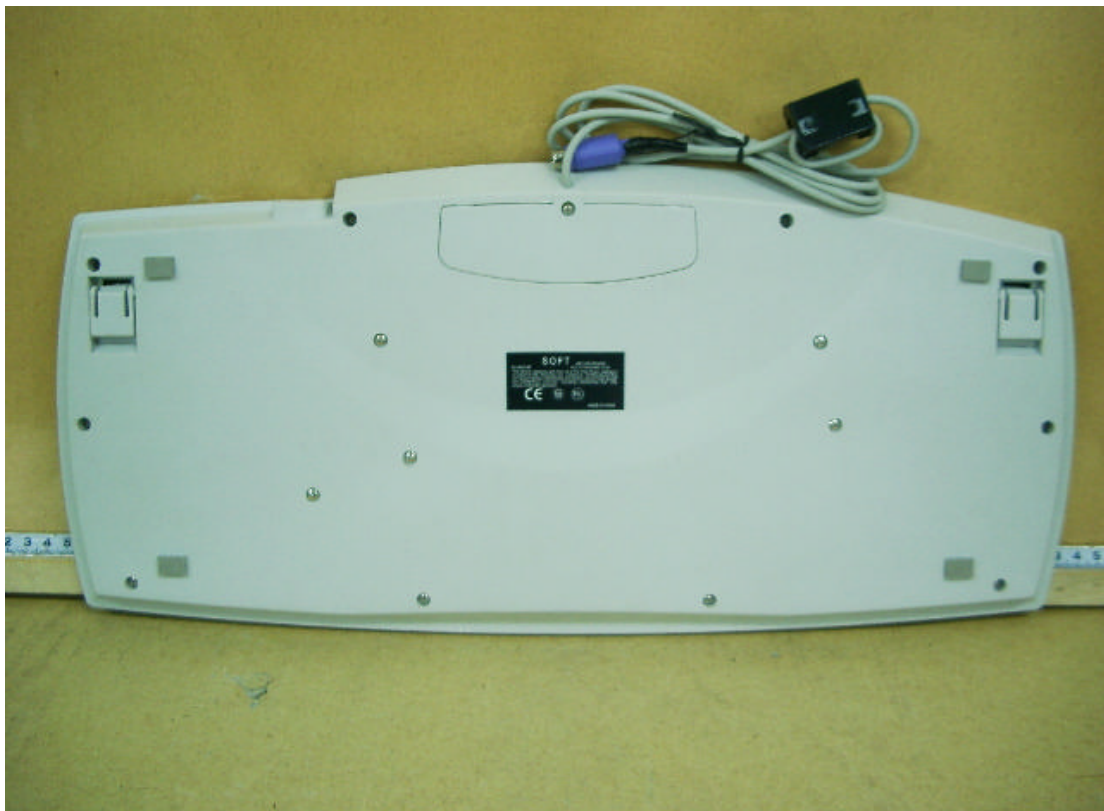

## **APPENDIX 3**

### **CONDUCTED EMISSION PLOT RADIATED EMISSION DATA**



Data#: 18 File#: 0683c.emi

Date: 2002-12-04 Time: 20:08:28

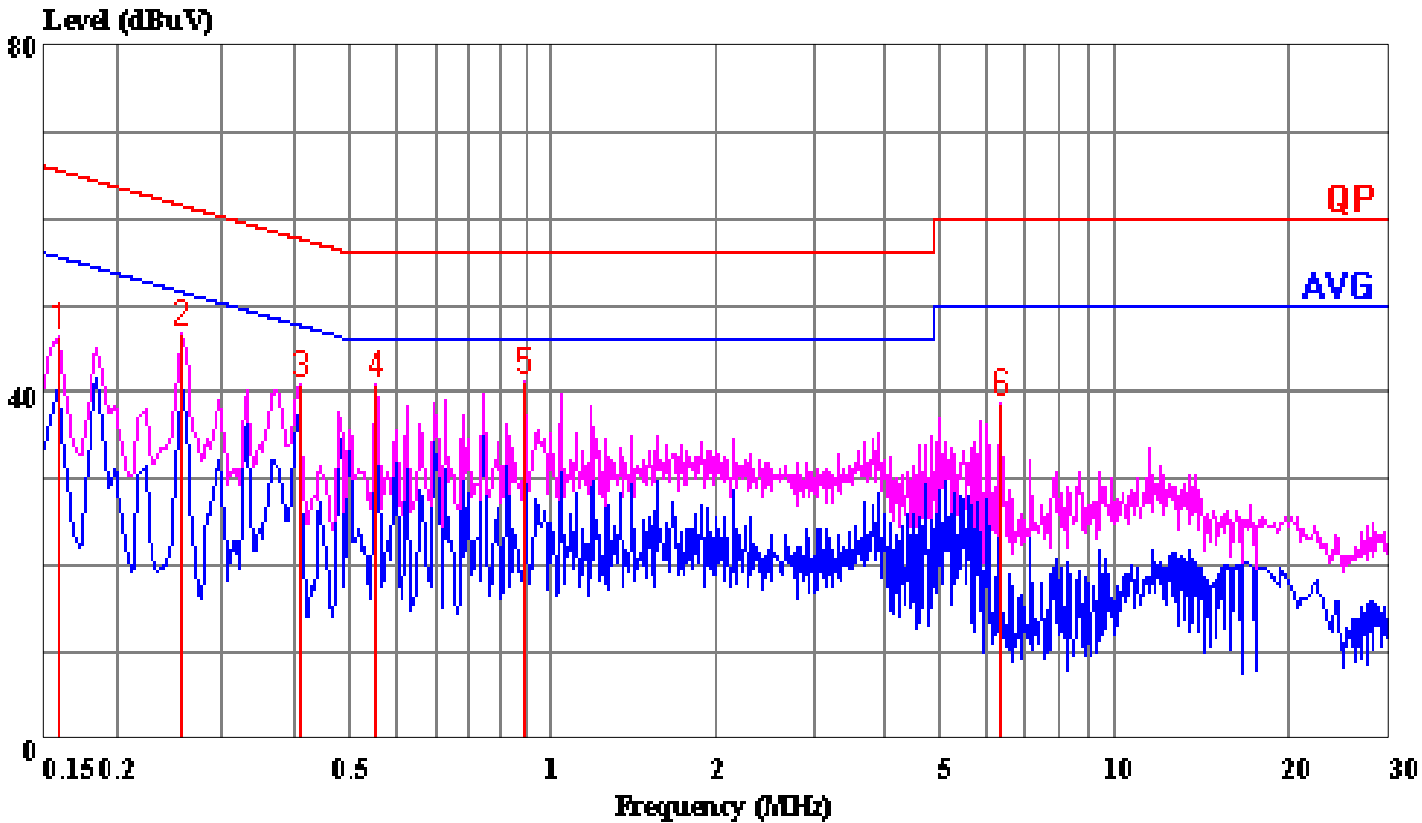

(Conducted)

Trace: 7 8

Ref Trace:

Condition: LINE  
Report No. : 02E0683  
Test Engr. : JIMMY CHEN  
Company : TAIWAN TAI-HAO ENTERPRISE CO., LTD.  
EUT : F21 XP SERIES  
Test Config : EUT / ALL PERIPHERALS  
Type of Test: EN55022 CLASS B  
Mode of Op. : NORMAL MODE

Page: 1

	Read Freq	Read Level	Factor	Level	Limit Line	Over Limit	Remark
	MHz	dBuV	dB	dBuV	dBuV	dB	
1	0.158	46.34	0.03	46.37	65.56	-19.19	Peak
2	0.258	46.72	0.04	46.76	61.51	-14.75	Peak
3	0.410	40.76	0.06	40.82	57.64	-16.82	Peak
4	0.555	40.80	0.07	40.87	56.00	-15.13	Peak
5	0.994	41.13	0.10	41.23	56.00	-14.77	Peak
6	6.488	38.42	0.29	38.71	60.00	-21.29	Peak

Data#: 17 File#: 0683c.emi

Date: 2002-12-04 Time: 20:07:59

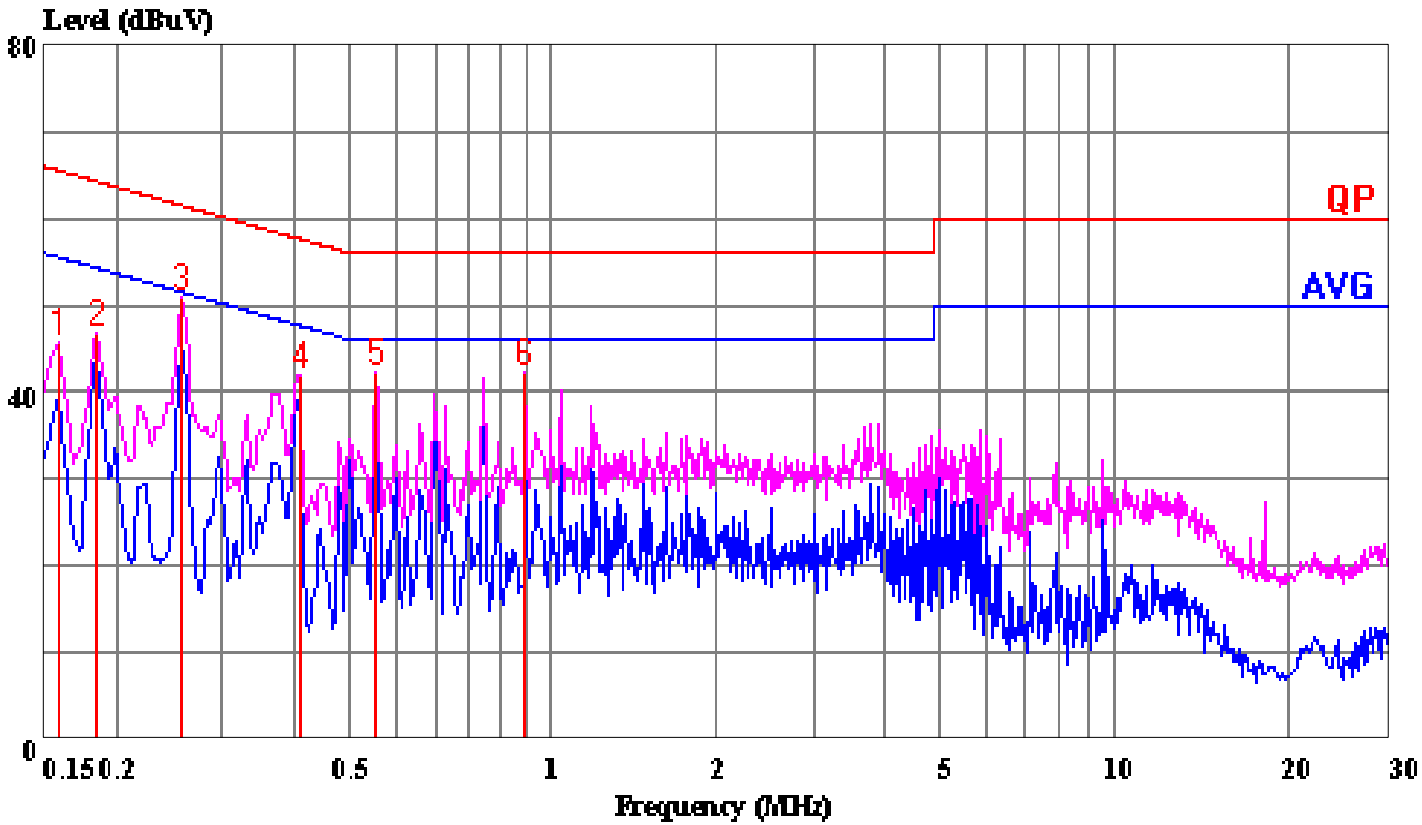

(Conducted)

Trace: 15 16

Ref Trace:

Condition: NEUTRAL  
Report No. : 02E0683  
Test Engr. : JIMMY CHEN  
Company : TAIWAN TAI-HAO ENTERPRISE CO., LTD.  
EUT : F21 XP SERIES  
Test Config : EUT / ALL PERIPHERALS  
Type of Test: EN55022 CLASS B  
Mode of Op. : NORMAL MODE

Page: 1

	Freq	Read Level	Factor	Level	Limit Line	Over Limit	Remark
	MHz	dBuV	dB	dBuV	dBuV	dB	
1	0.158	45.66	0.03	45.69	65.56	-19.87	Peak
2	0.183	46.74	0.03	46.77	64.33	-17.56	Peak
3	0.258	50.93	0.04	50.97	61.51	-10.54	Peak
4	0.410	41.92	0.06	41.98	57.64	-15.66	Peak
5	0.555	42.24	0.07	42.31	56.00	-13.69	Peak
6	0.994	42.01	0.10	42.11	56.00	-13.89	Peak

Data#: 1 File#: 0683d.emi  
D-Site

Date: 2002-12-04 Time: 22:30:58

Condition: VERTICAL / 10m  
Report No. : 02E0683  
Test Engr. : JIMMY CHEN  
Company : TAIWAN TAI-HAO ENTERPRISE CO., LTD.  
EUT : F21 XP SERIES  
Test Config : EUT / ALL PERIPHERALS  
Type of Test: EN55022 CLASS B  
Mode of Op. : NORMAL MODE

Page: 1

	Freq	Read Level	Factor	Level	Limit Line	Over Limit	Remark
	MHz	dBuV	dB	dBuV/m	dBuV/m	dB	
1	39.180	34.45	-9.65	24.80	30.00	-5.20	Peak
2	48.030	34.20	-8.09	26.12	30.00	-3.89	Peak
3	60.080	34.29	-10.71	23.58	30.00	-6.42	Peak
4	74.530	34.71	-12.59	22.12	30.00	-7.88	Peak
5	120.050	32.88	-9.01	23.87	30.00	-6.13	Peak
6	180.350	34.32	-8.19	26.13	30.00	-3.87	Peak
7	242.800	35.40	-8.56	26.84	37.00	-10.16	Peak
8	355.450	30.16	-2.82	27.34	37.00	-9.66	Peak
9	498.880	31.19	0.89	32.08	37.00	-4.92	Peak

Data#: 2 File#: 0683d.emi  
D-Site

Date: 2002-12-04 Time: 22:41:13

Condition: HORIZONTAL / 10m  
Report No. : 02E0683  
Test Engr. : JIMMY CHEN  
Company : TAIWAN TAI-HAO ENTERPRISE CO., LTD.  
EUT : F21 XP SERIES  
Test Config : EUT / ALL PERIPHERALS  
Type of Test: EN55022 CLASS B  
Mode of Op. : NORMAL MODE

Page: 1

	Freq	Read Level	Factor	Level	Limit Line	Over Limit	Remark
	MHz	dBuV	dB	dBuV/m	dBuV/m	dB	
1	40.400	32.15	-9.50	22.65	30.00	-7.35	Peak
2	59.800	31.82	-10.53	21.29	30.00	-8.71	Peak
3	73.730	31.12	-12.59	18.53	30.00	-11.47	Peak
4	119.950	32.44	-9.01	23.43	30.00	-6.57	Peak
5	179.930	31.80	-8.12	23.68	30.00	-6.32	Peak
6	240.000	31.78	-8.58	23.20	37.00	-13.80	Peak
7	355.330	31.78	-2.82	28.96	37.00	-8.04	Peak
8	500.350	31.43	0.90	32.33	37.00	-4.67	Peak