

Ultrasonic Ceiling Mounted Line Voltage Occupancy Sensor

California Title 20 Compliant

Cat. No. ODC05-UDW, ODC10-UDW, ODC20-UDW

No Minimum Load Required

Compatible with electronic and magnetic ballasts, electronic and magnetic low-voltage transformers, incandescent lamps, and fans

INSTALLATION INSTRUCTIONS



Operating Temperature: 32° to 104°F (0° to 40°C)

PK-93307-10-00-2A-X2

Rating: 6A-6AX 250V 720-1440 W/VA 120-240 50Hz

120V 60Hz	8A, Electronic Ballast	277V 60Hz	5A, Electronic Ballast
	800W/VA, Tungsten, Ballast		1200VA, Ballast
	1/4 hp		1/3 hp

CATALOG ITEMS

Cat. No.	Description	Voltage Range	Current Consumption	Coverage	Suggested Mounting Location
ODC05-UDW	1-Way Ultrasonic	120-277,50/60Hz	60-30ma	500 sq. ft.	Mount in corner/over doorway
ODC10-UDW	2-Way Ultrasonic	120-277,50/60Hz	60-30ma	1000 sq. ft.	Mount in corner/over doorway
ODC20-UDW	2-Way Ultrasonic	120-277,50/60Hz	60-30ma	2000 sq. ft.	Mount in corner/over doorway

WARNINGS AND CAUTIONS:

For Occupancy Sensors installed to control Emergency Lighting Equipment:

If this equipment is being used for Emergency Lighting and Power Equipment, please adhere to the following information. This equipment is rated for only 25C if used on Emergency Lighting Equipment. Apply the "Emergency Circuits" label (provided) to the front cover.

IMPORTANT SAFEGUARDS

When using electrical equipment, basic safety precautions should always be followed, including the following:

- READ AND FOLLOW ALL SAFETY INSTRUCTIONS.
- DO NOT use outdoors.
- DO NOT mount near gas or electric heaters.
- Equipment should be mounted in locations and at heights where it will not readily be subjected to tampering by unauthorized personnel.
- The use of accessory equipment not recommended by manufacturer may cause an unsafe condition.
- DO NOT use this equipment for other than the intended use.

SAVE THESE INSTRUCTIONS

All servicing shall be performed by qualified service personnel. If any Emergency Circuits are fed or controlled from this panel, it must be located electrically where fed from a UPS, generator, or other guaranteed source of power during emergencies and power outage situations.

WARNINGS AND CAUTIONS:

- TO AVOID FIRE, SHOCK, OR DEATH; **TURN OFF POWER AT CIRCUIT BREAKER OR FUSE AND TEST THAT POWER IS OFF BEFORE WIRING!**
- To be installed and/or used in accordance with appropriate electrical codes and regulations.
- If you are unsure about any part of these instructions, consult an electrician.
- Sensors must be mounted on a vibration free surface.
- Do not terminate using data type wire, such as Cat 5/5E.
- Do not mount sensors closer than 10 feet to each other.
- All sensors must be mounted at least 6 feet away from air vents, air handlers, and reflective surfaces (windows/mirrors).
- Do not touch the surface of the lens. Clean outer surface with a damp cloth only.

TOOLS NEEDED TO INSTALL YOUR SENSOR

Slotted/Phillips Screwdriver Small Slotted Screwdriver Cutters Wire stripper

PARTS INCLUDED LIST

Sensor (1) 4" x 4" Mounting Plate (1) #6-32 x 1-1/2" Screw (2)
Emergency Label (1) Angled Light Pipe (1) Tubing Barrier (1)
Low Voltage Connector (1)

DESCRIPTION

The Occupancy Sensor is a LINE-voltage ultrasonic sensor to automatically control lighting. The sensor turns the lights ON and keeps them ON whenever occupancy is detected and will turn them OFF after the "delayed-off time" has expired. The sensor continually analyzes and adjusts to changing conditions. The sensor uses the latest microprocessor-based technology which permits it to continually adjust and optimize its performance. Ultrasonic (doppler shift) motion detection gives maximum sensitivity that yields a sensor with excellent performance.

INSTALLING YOUR OCCUPANCY SENSOR

NOTE: Use check boxes when Steps are completed.

Step 1

WARNING: TO AVOID FIRE, SHOCK, OR DEATH; TURN OFF POWER at circuit breaker or fuse and **TEST** that power is off before wiring!

Step 2

Identifying your wiring:

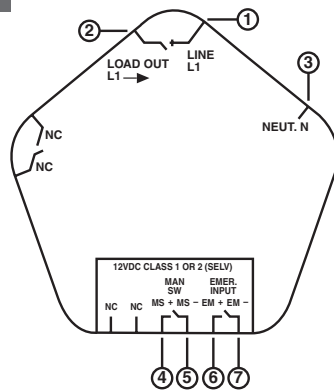

- Line (Hot) - L1
- Load - L1 →
- Neutral - N
- Manual Switch +
- Manual Switch -
- Emergency Interface +
- Emergency Interface -

Step 3

Preparing and connecting wires:

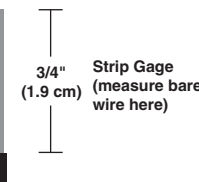
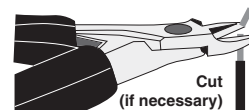

- Make sure that the ends of the wires from the electrical box are **straight (cut if necessary)**.
- Remove insulation from each wire in electrical box as shown.
- Wire per Specifications:
- Line, Neutral, Load Wires (Copper)**
Wire range: #12-18 AWG, 3.3 - 0.75 mm square - Torque rating: 20 lb-in, 23 kgf-cm.
- Control Wires (Manual Switch and Emergency Interface)**
Wire range: #16-26 AWG, 4.0 - 0.12 mm square - Torque rating: 2.5 lb-in, 2.88 kgf-cm.

Step 4 Installing your Sensor:

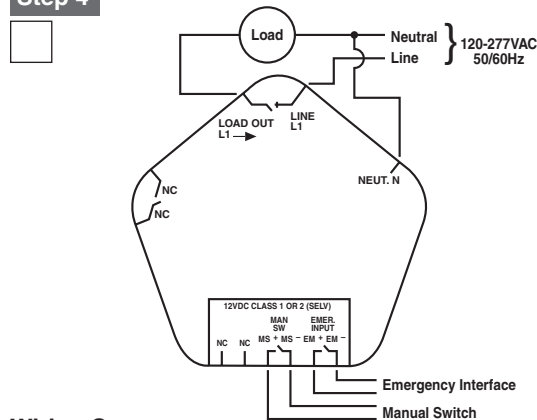

Wiring Sensor

Connect wires per WIRING DIAGRAM as follows:

- Insert wires into proper terminals. Use a screwdriver to turn terminal screws clockwise and secure wires.
 - Line wire to Line terminal.
 - Neutral wire to Neutral terminal.
 - Load wire to Load terminal.
 - Manual Switch and Emergency Interface to their respective marked terminals.
- NOTE: When wiring Manual Switch and Emergency Interface Class 2, use the provided tubing for insulation inside the junction box.

Mount Sensor in Electrical Box

- To mount inside 4" octagon 2.125" deep ceiling electrical box, refer to Figure 1.
- Dress line voltage wires to provide enough clearance in electrical box when device is installed.
 - Partially thread #8-32 screws (not included) into the mounting holes of the electrical box.
 - Pull out the two coasters that align with the two screws.
 - Align sensor so that it fits between the mounting holes of the electrical box and insert over mounting screws.
 - Push in the two coasters that align with the two screws.
 - Tighten mounting screws firmly.

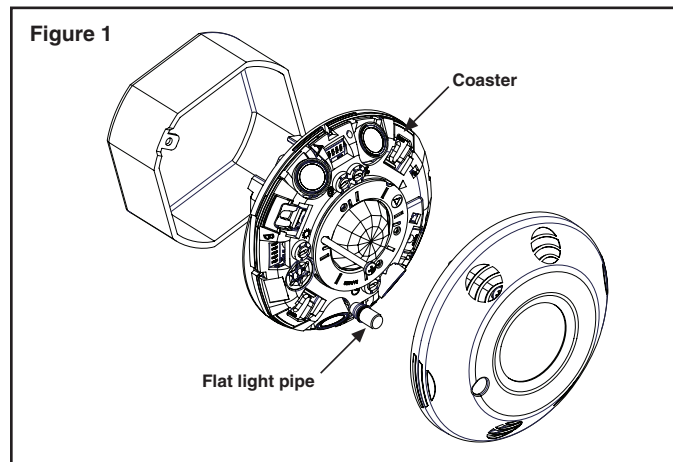

MOUNT SENSOR IN ELECTRICAL BOX WITH MUD RING

To mount inside 4" square 1.5" deep ceiling electrical box with mud ring, refer to Figure 2 below.

- Ensure that conduit/cable entry clamp is located in corner of electrical box.
- Dress line voltage wires to provide enough clearance in electrical box when device is installed.
- Install a two-gang mud ring (not included) on electrical box.
- Partially thread the two #6-32 screws provided into the mounting holes of the electrical box.
- Pull out the two coasters that align with the two screws.
- Align sensor so that it fits between the mounting holes of the electrical box and insert over mounting screws.
- Push in the two coasters that align with the two screws.
- Tighten mounting screws firmly.

Figure 2

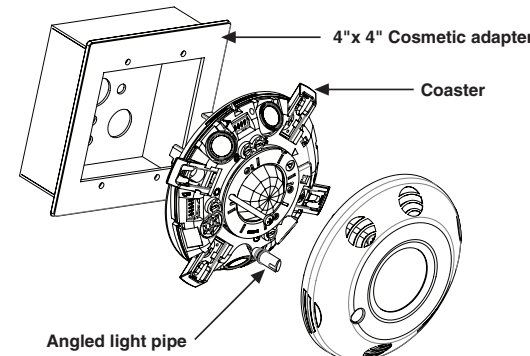

OCCUPANCY SENSOR OPERATION

Motion detection by the ultrasonic sensor will turn the lights ON as well as keep them ON. When motion is not detected, the lights will turn OFF after the delayed-off time.

- Delayed-Off time:** The sensor is designed to turn the lights OFF if no motion is detected after a specified time. This length of time is called the delayed-off time and is set using the timer (Black) knob on the sensor.
- Walk-through Mode:** The walk-through feature is useful when a room is momentarily occupied. The walk-through feature works as follows: When a person enters the room, the lights will turn ON. If the person leaves the room before the default walk-through timeout of 2.5 minutes, the sensor will turn the lights OFF 2.5 minutes later. If the person stays in the room for longer than 2.5 minutes, the sensor will proceed with the standard operation.
- Reset Device State:** To reset Auto adapting and photocell settings to factory default.
- Manual ON/OFF Switch:** Use to override occupancy and manually turn the lights ON or OFF by pressing the low voltage momentary/toggle switch. Pressing manual switch will reset the time delayed OFF timer and lights will turn OFF after the delayed-off timer expires.
- Emergency Interface:** This input is intended for use with BMS (Building Management System) or any contact closure to force the lights ON in case of emergency. Lights will stay ON until emergency signal is cleared.

Modes of Operation: Selectable using Bank C Dip Switches

The Auto ON/Auto OFF Occupancy Sensor can be turned ON and OFF automatically based on occupancy, a timer, panel or BMS input, and manually from an optional low voltage switch.

- MANUAL ON (Mode 1)**
Occupants must press the low voltage switch to turn the load ON. When the occupancy sensor is the only input keeping the load ON, the load turns OFF when the sensor time delay expires. If the sensor input re-triggers within 30 seconds after the load turns OFF, the load turns ON again. After the 30 seconds expire with no sensor input, press the momentary switch to turn the load ON.
- AUTO ON (Mode 2)**
The load can be turned ON based on occupancy detection or by using the optional switch input. When the load is turned OFF using the switch, the Occupancy Sensor does not turn it ON automatically until after the sensor time delay expires (e.g., presentation mode). When the sensor's time delay expires, the sensor reverts to Auto ON mode and turns the load ON with the next input from the sensor or switch input.

Test Mode: To set the delayed-off time to 4 seconds for performing a walk test. While the sensor is in test mode, the LED's will flash YELLOW once every second.

- ENSURE POWER IS ON.
- Remove front cover.
- Locate dip switch 3 in Bank B (B3) (refer to Table 2). B3 will be in the OFF position from the factory.
- To enter Test mode, move switch to ON. The Test mode has now been entered with a 4 second time-out. **NOTE:** If B3 is already in the ON position, then Test mode can be entered by just moving it to the OFF and then ON position.

NOTES:

- The timer will remain in the 4 second Test mode for 15 minutes, then automatically exit Test mode and reset to the delayed-off time setting as defined by the Black timer knob.
- To manually take the timer out of the 4 second Test mode, simply move switch B3 back to OFF.
- Entering Test mode will reset all adapted settings.

AUTO ADAPTING

The Sensor continually analyzes the parameters of the motion detection signal and adjusts its internal operation to maximize detection of motion while minimizing the effects of noise (electrical noise, air currents, temperature changes, etc...).

Operation

When the sensor is first installed, the delayed-off time for the occupied mode is based on the Time adjustment settings. While the sensor is in use, the delayed-off time will change, based on how the sensor adapts to the room conditions. The adapted settings can be reset by moving B3 from OFF to ON to OFF position.

Occupancy Pattern Learning For Delayed-Off Time

The sensor will automatically change the Delayed-Off Time in response to detected occupancy patterns. The Delayed-Off Time will be decreased if large periods of vacancy are detected, which will result in energy savings. The Delayed-Off Time will be increased if false-off conditions are detected.

Occupancy Pattern Learning for Ultrasonic Technology

The sensor learns the occupancy patterns of a space during the course of a day, for a seven day period. The sensor will adjust the sensitivity to make it less likely to turn ON during a historically vacant time period.

PHOTOCELL AND DAYLIGHTING OPERATIONS

Daylight harvesting is used for additional energy savings. The photocell holds the lights OFF when sufficient ambient light is present. Typical light levels are measured in foot-candles or lux, and average office areas are designed to utilize 50-60 foot candles/500-600 lux. The "Daylight Design Level" (DDL), when set per the calibration section, will be the set point which engages the hold-off feature for daylight harvesting.

CALIBRATION

After the sensor is installed, the photocell must be configured correctly to maintain the desired light level and gain additional energy savings. To achieve this, the installer first needs to understand Closed and Open Loop Daylighting, then decide which application best fits the customer's needs before configuring and calibrating the device.

- Open Loop:** When a photocell (light pipe) is focused on an area which is primarily illuminated by natural light from windows or skylights, along with a minimal amount of artificial light from the lights it is controlling. **NOTE:** Use the **angled light pipe** for Open Loop applications. Open Loop **MUST** be used only with Manual Calibration mode. The sensor will not enter Automatic Calibration mode if Open Loop Daylight Harvesting is selected.
- Closed Loop:** When a photocell (light pipe) is focused on an area which is primarily illuminated by the lights it is controlling. **NOTE:** Use the **flat light pipe** for Closed Loop applications.

Please allow a 30 second warm up period after applying power. For best calibration results, personnel should maintain at least a 6 foot distance from the device 2 minutes after the start of Auto and Manual Calibration. **NOTE:** to disable photocell or cancel calibration turn knob to SET/OFF for longer than 5 seconds (RED LED followed by YELLOW flash). When changing photocell modes or recalibrating, disable photocell and follow directions below:

Manual Mode: Available for both Open and Closed Loop applications to quickly configure the Daylight Design Level (DDL). Calibration should always be done when ambient light is at user's desired level.

Procedure - Open Loop /Closed Loop

1. Move dip switch C4 to ON (for Open Loop), or to OFF (for Closed Loop).
2. Install appropriate light pipe.
 - **Open Loop:** Install angled light pipe with the longest side facing toward the natural light source (window) - see Figure 4A.
 - **Closed Loop:** Install the flat light pipe (factory installed).
3. Turn the photocell knob (fully counterclockwise) to SET/OFF for 2 seconds (LED will be solid RED indicating the device has entered Manual Calibration mode). Then turn the knob to SETPOINT (1X) - see Figure 5.
4. Re-install sensor cover.
5. Lights are forced ON for 3 minutes, then OFF for 1 minute (Open Loop only).
6. LED blinks RED (3 minutes). **Optional** - During this time, the DDL can be adjusted by turning the knob up or down. **NOTE:** The LED blinks BLUE when the knob setting has changed.
7. When Manual Calibration is complete, the LED will resume normal operation. The device is now operating in Manual mode.

Auto Mode: Auto mode is available ONLY for Closed Loop applications to configure the DDL in 24 hours. The sensor will not enter Auto Calibration mode if Open Loop Daylight Harvesting is selected.

Procedure

1. Move dip switch C4 to OFF position.
2. Install the flat light pipe (factory installed).
3. Turn the photocell knob (fully clockwise) to AUTO (LED will be solid GREEN for 24 hours indicating the device has entered Auto Calibration mode).
4. Re-install sensor cover.
5. When Auto Calibration is complete, the LED will resume normal operation. The device is now operating in Auto mode.

PHOTOCELL OPERATION

- In order to keep the lights from needlessly cycling ON and OFF, the OFF trigger point is set at a higher light level than the ON trigger point. In addition, there is a delay time that must be met which requires the light level to be above or below the trigger point for a period of time before a light change occurs. For example, there may be a 10% hysteresis gap between the OFF and ON trigger points, along with a 5 minute delay time to turn OFF the lights and a 1 minute time delay to turn ON the lights.
- OFF and ON trigger point levels can be adjusted at any time using the Photocell knob. **NOTE:** In order to make quick adjustments to DDL, the delay time for lights ON/OFF will be reduced from 1 min/ON and 5 min/OFF, to 30sec/ON or OFF once Photocell knob change is recognized. The reduced delay time will expire 2 minutes after knob change occurs.
- **NOTE:** The LED blinks BLUE when the knob setting has changed.
- To disable photocell or cancel calibrations turn the knob to SET/OFF (RED LED, YELLOW flash).

Open Loop

1. In Open Loop application the longer side of the angled light pipe must be facing toward the natural light source (window). See Figure 4A.
2. The graph in Figure 4A tracks the value of a linear photocell throughout a day. It is assumed that it is a cloudless day so the increase of the daylight is relatively linear. The far left of the graph starts out at night and shows a very low level reading. At dawn, the level begins to increase. At some point, based on the setting of the trigger point, the lights will be turned OFF since there is enough contribution from the daylight. The photocell reading will begin to decrease around noon until the level matches the trigger point, then lights will be turned back ON.

Figure 4A

NOTE: Long side of angled light pipe must face toward natural light source (window).

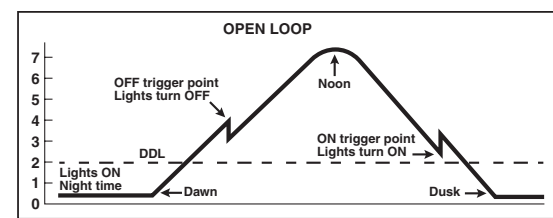
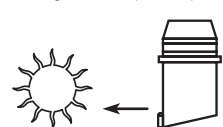

Closed Loop

The graph in Figure 4B tracks the value of a linear photocell throughout a day. It is assumed that it is a cloudless day and that the desired light level is the same level without external light influence and only by the fixture(s). At the far left, the lights are ON because the area is occupied and since it is still night, there is no contribution from daylighting. As dawn arrives, the photocell level begins to increase as the daylight increases. In order to keep the light level from dropping below the trigger point, and in this case below the desired light level in the area (DDL), the trigger point is set to 2.5 times the level read with only the fixture(s). That way, the light is still adequate to hold the lights OFF. This is shown in the graph at the point where the level suddenly drops. The photocell level then continues to increase until around noon. As the daylight decreases, the area light eventually drops to near the desired light level. Before reaching this point, the lights are turned back ON, indicated by the sudden increase in the photocell level.

Figure 4B

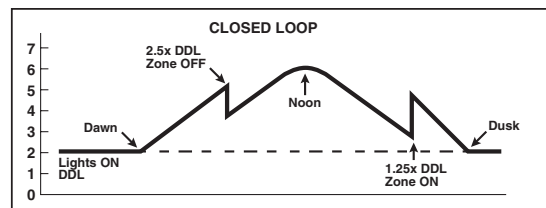

LED INDICATORS

- RED** - Solid for 3 minutes then blinks for 3 minutes during photocell manual calibration. Solid when device malfunctions.
- GREEN** - Blinks upon US detection. Can be disabled by moving B4 to ON (see table 2). Solid for 24 hours during photocell auto calibration.
- YELLOW** - Blinks in test mode. Solid with emergency interface/BMS input on.
- BLUE** - Blinks when the knob setting has changed.

SETTINGS

Default Settings:

Adjust knob settings as per "recommended manual settings," (refer to Figure 5 and Table 1). All switches in the OFF position, except A3, A4, C1, C2, C3 are set to ON (refer to Table 2).

Figure 5 - Knob Settings

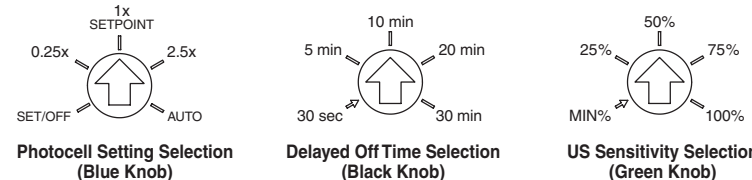

Knob Color	Symbol	Function	Knob Setting	Factory Default Setting
Green		Sets the ultrasonic range	Range Setting Full CCW = min. (OFF) Full CW = max.	50 %
Black		Delayed - Off Time	Full CCW = min. (30 sec) Full CW = max. (30 min.)	50 % (10 min)
Blue		Ambient Light Override (Photocell)	Full CCW - SET/OFF (NO ambient light override) Full CW - Auto Calibration Range - 3-16000 LUX	0 %

SWITCH	SWITCH FUNCTIONS	SWITCH SETTINGS	
		Bank A	Bank B
A3	Manual Mode	Auto Adapting Enabled	Auto Adapting Disabled
A4	Walk-Through	Walk-Through Enabled	Walk-Through Disabled
B1	Forced Mode	Normal	Override Enabled (B2)
B2	Forced State	Override OFF	Override ON
B3	Test Mode	Disabled	Enabled. OFF → ON
B4	LEDs State	LEDs Enabled	LEDs Disabled
B5	Reset Device State	OFF → ON → OFF	

Bank C	C1	C2	C3	Load
Mode 1	OFF	OFF	OFF	Manual ON *
Mode 2	ON	ON	ON	Auto ON *
C4	Daylight Harvesting - OFF Closed Loop / ON Open Loop			

* All modes are Auto OFF.

Figure 6 (Cat. No. ODC05) Field-of-View Ranges

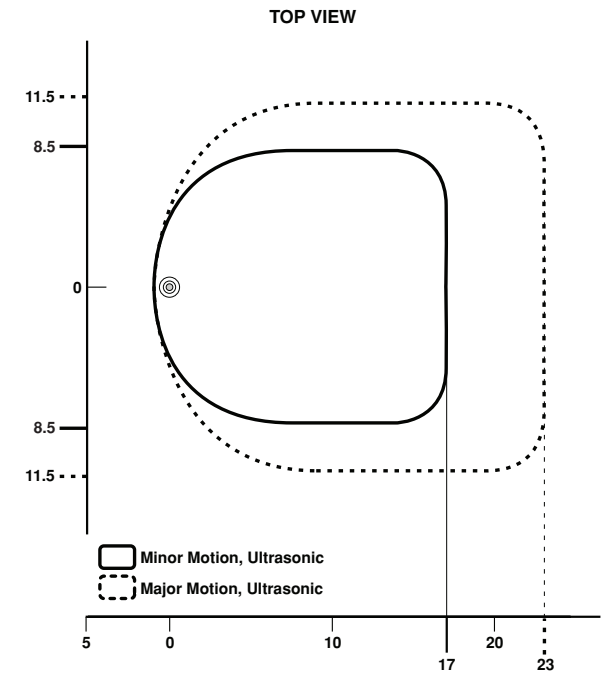

Figure 8 (Cat. No. ODC20) Field-of-View Ranges

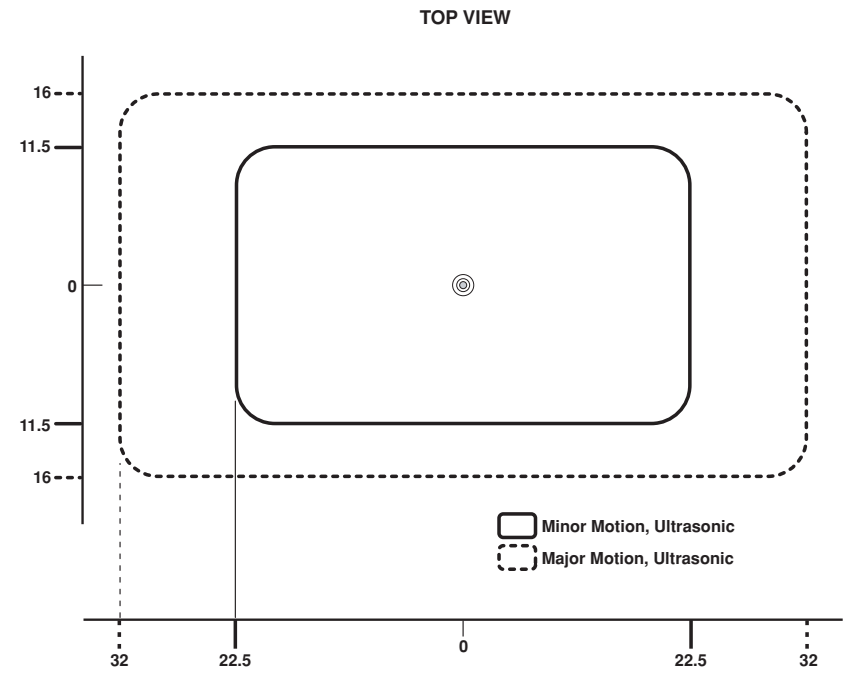
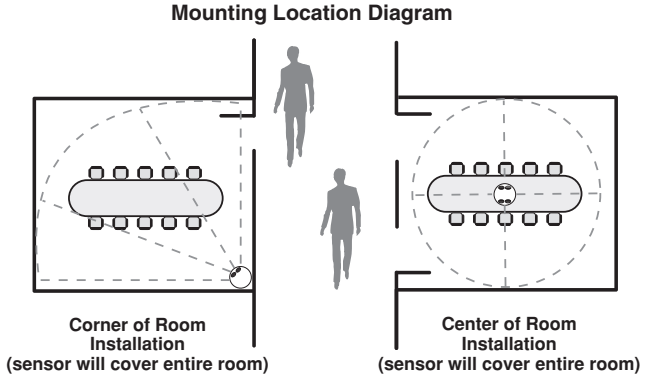
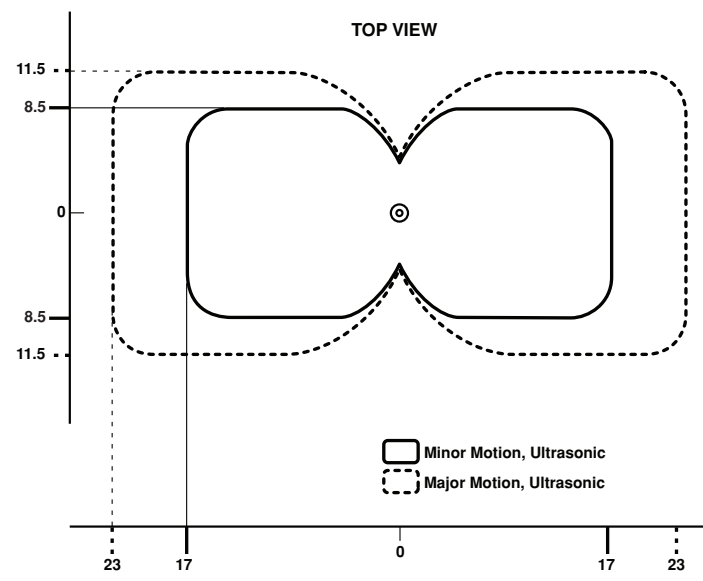

Figure 7 (Cat. No. ODC10) Field-of-View Ranges



NOTE: When mounting device, do not point sensor openings towards the opening of a door or strong air currents.

TROUBLESHOOTING

- **Lights do not turn ON**
 - Circuit breaker or fuse has tripped.
- **Lights stay ON**
 - Constant motion. **To Test:** Reduce GREEN knob by 25%; remove motion source. If unsatisfactory, move sensor.
- **Light turns ON too long**
 - Timer setting too high. **To Test:** Check switch settings. Typical setting is 10 minutes.
 - LED illuminates solid RED for longer than 5 minutes, device malfunction, contact technical assistance.

PRODUCT INFORMATION

- For technical assistance, contact us at 1-800-824-3005
- Visit our website at www.leviton.com

FCC COMPLIANCE STATEMENT

This device complies with part 15 of the FCC rules. Operation is subject to the following two conditions: (1) This device must not cause harmful interference, and (2) This device must accept any interference received, including interference that may cause undesired operation. Any changes or modifications not expressly approved by Leviton could void the user's authority to operate this equipment.

© 2013 Leviton Mfg. Co., Inc.

PK-93307-10-00-2A-X2

LIMITED 5 YEAR WARRANTY AND EXCLUSIONS

Leviton warrants to the original consumer purchaser and not for the benefit of anyone else that this product at the time of its sale by Leviton is free of defects in materials and workmanship under normal and proper use for five years from the purchase date. Leviton's only obligation is to correct such defects by repair or replacement, at its option, if within such five year period the product is returned prepaid, with proof of purchase date, and a description of the problem to Leviton Manufacturing Co., Inc., Att: Quality Assurance Department, 201 North Service Road, Melville, New York 11747. This warranty excludes and there is disclaimed liability for labor for removal of this product or reinstallation. This warranty is void if this product is installed improperly or in an improper environment, overloaded, misused, opened, abused, or altered in any manner, or is not used under normal operating conditions or not in accordance with any labels or instructions. There are no other or implied warranties of any kind, including merchantability and fitness for a particular purpose, but if any implied warranty is required by the applicable jurisdiction, the duration of any such implied warranty, including merchantability and fitness for a particular purpose, is limited to five years. Leviton is not liable for incidental, indirect, special, or consequential damages, including without limitation, damage to, or loss of use of, any equipment, lost sales or profits or delay or failure to perform this warranty obligation. The remedies provided herein are the exclusive remedies under this warranty, whether based on contract, tort or otherwise.