

Load Centers

1-Phase Indoor and 1-Phase & 3-Phase Outdoor Enclosures—Knockout Diagrams

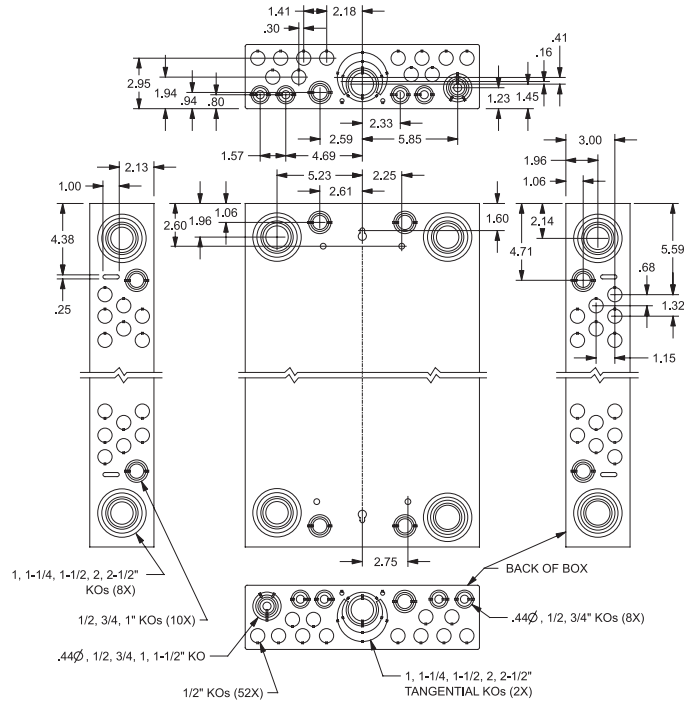

**ES, PL, and Generator Ready
1 Phase Load Centers
Indoor**

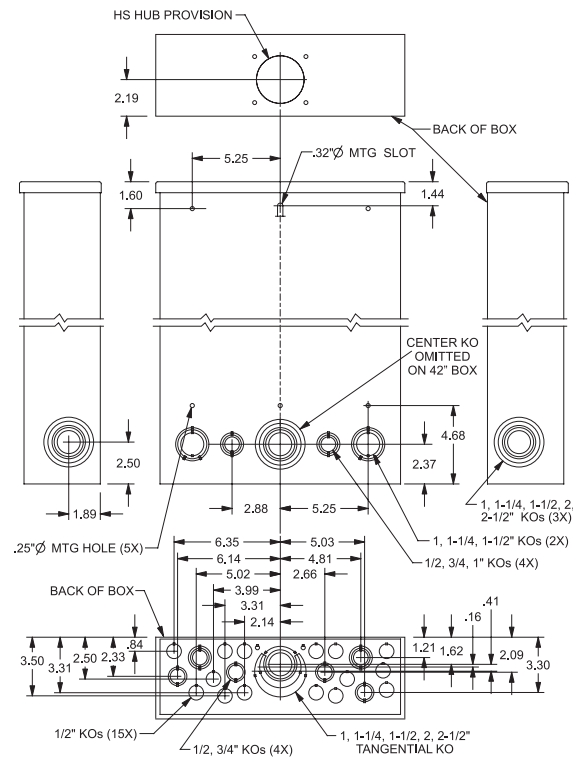

**ES, PL, and Generator Ready
1 and 3 Phase Load Centers
Outdoor**

Load Centers

Outdoor Enclosures—Knockout Diagrams

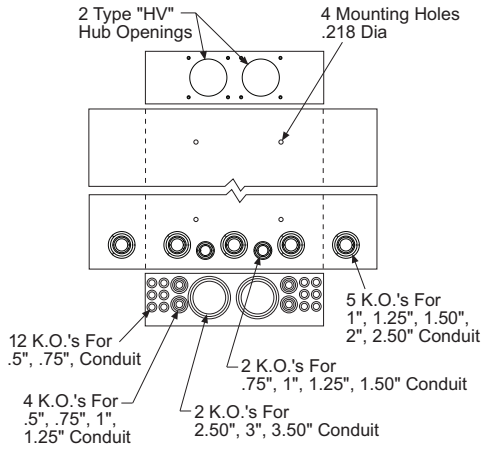

**Outdoor 400A
Load Center**

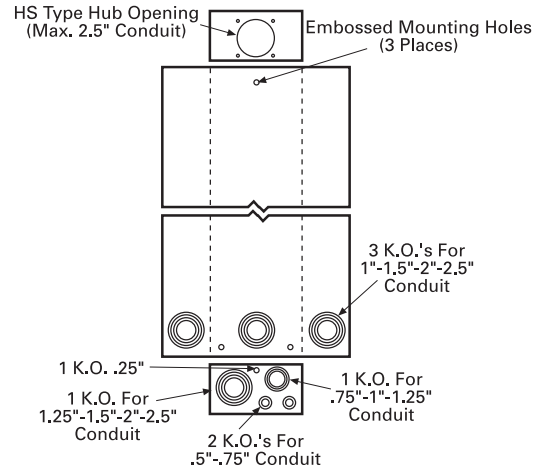

W0406ML1125CU

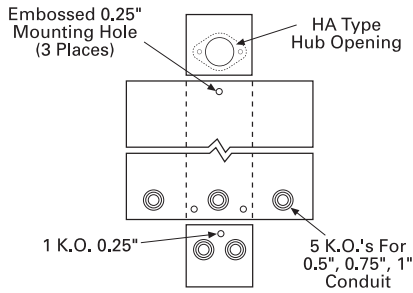

W0204ML1060

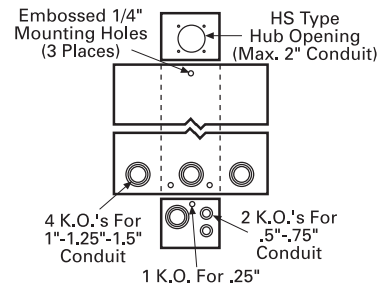

W0408ML1125

Load Centers

Outdoor Enclosures—Knockout Diagrams

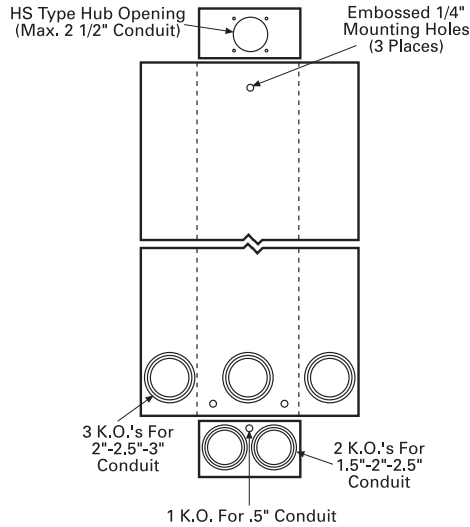

WB2225 and WB32225

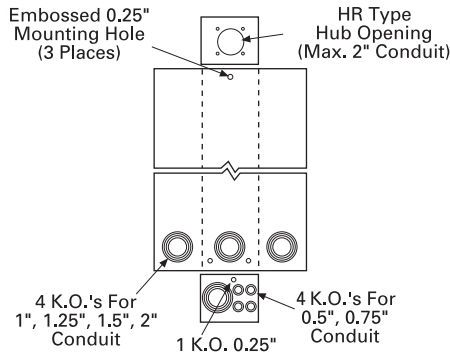

W0204ML1125

W0303ML3100

WB3100

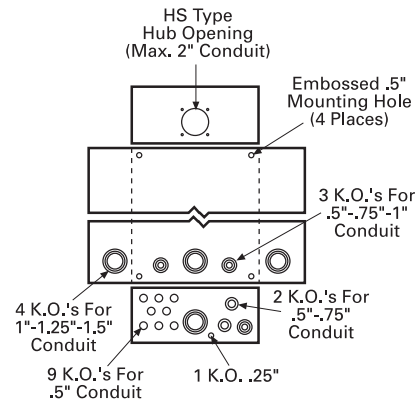

W0612ML1125

W0816ML1125

Load Centers

Indoor Enclosures—Knockout Diagrams

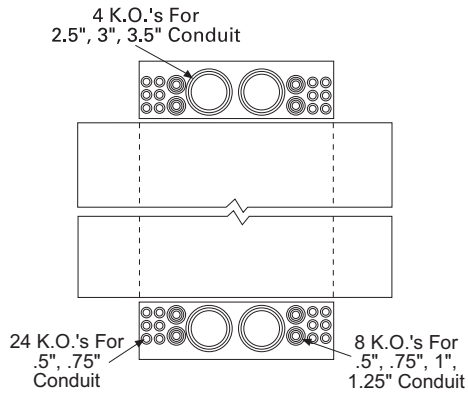

**Indoor 300-400A
Load Center**

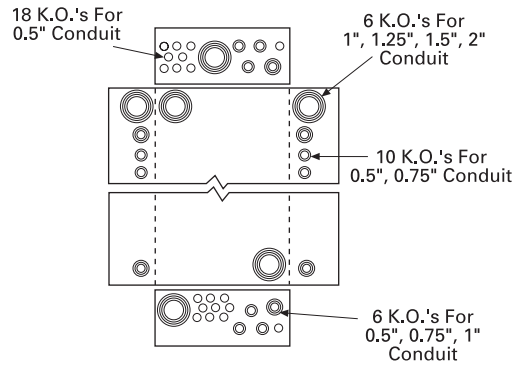

E0612ML1125

E0816ML1125

E1224ML1100F

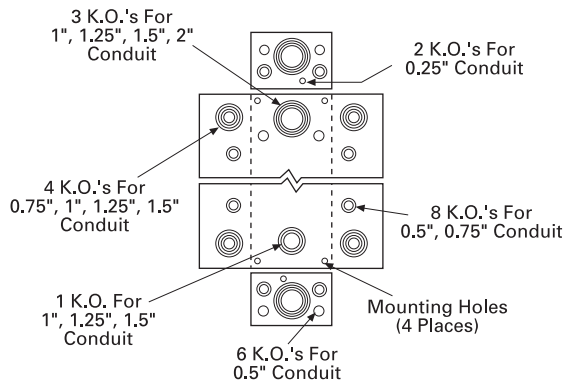

E0408ML1125

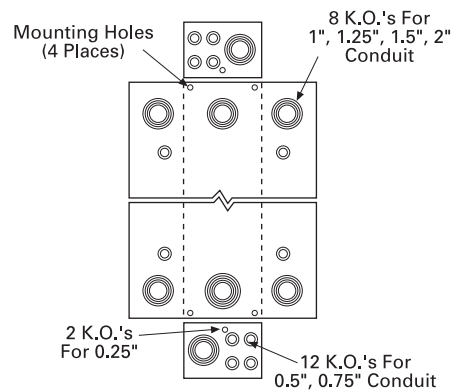

E0303ML3100SCU

EB3100

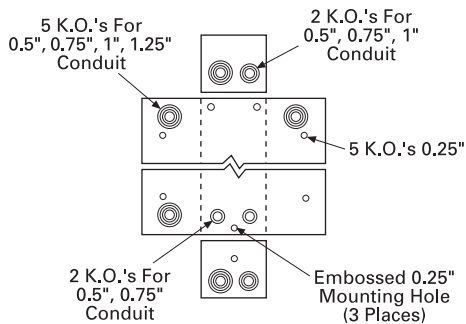

E0204ML1060

Load Centers

Cross Reference

Ultimate Load Center Cross Reference to ES Series and PL Series

Phase	Type	Current Sku	ES Series	PL Series
1 Phase	Indoor	New	—	P3040L1200SG
		New	—	P4040L1200SG
		New - Higher Circuits	—	P4260L1225CUSG
		New - Higher Circuits	S3054L1200	P3054L1200CU
		New - Higher Circuits	S5470B1225	P5470B1225CU
		New - Higher Circuits	S5470L1225	P5470L1225CU
		New - Higher Circuits	SW3054L1200	PW3054L1200CU
		G1212L1125	S1212L1125	-
		G1212L1125CU	—	P1212L1125CU
		G1224B1100	S1224B1100	-
		G1224B1100CU	—	P1224B1100CU
		G1224L1125	S1224L1125	-
		G1224L1125CU	—	P1224L1125CU
		G1224L1125CUSG	—	P1224L1125CUSG
		G1224L1200CU	S1224L1200	P1224L1200CU
		G1624B1100	S1624B1100	-
		G1624B1100CU	—	P1624B1100CU
		G1624B1100W	S1624B1100W	-
		G1624L1125	S1624L1125	-
		G1624L1125CU	—	P1624L1125CU
		G1624L1125CUSG	—	P1624L1125CUSG
		G1630B1150	S1630B1150	-
		G2020B1100	S2020B1100	-
		G2020B1100CP	S2020B1100P	-
		G2020B1100CU	—	P2020B1100CU
		G2020L1125	S2020L1125	-
		G2020L1125CU	—	P2020L1125CU
		G2020L1125CUW	S2020L1125W	—
		G2030B1150	S2030B1150	—
		G2030B1150CU	—	P2030B1150CU
		G2030L1125CUSG	—	P2030L1125CUSG
		G2030L1150	S2030L1150	—
		G2030L1150CU	—	P2030L1150CU
		G2030L1150CUSG	—	P2030L1150CUSG
		G2040B1200	S2040B1200	—
		G2040B1200CU	—	P2040B1200CU
		G2040L1200	S2040L1200	—
		G2040L1200CU	—	P2040L1200CU
		G2424B1100CU	—	P2424B1100CU
		G2424B1125	S2424B1125	—
		G2424L1125	S2424L1125	—
		G2424L1125W	S2424L1125W	—
		G2430B1150	S2430B1150	—
		G2430L1125CUSG	—	P2430L1125CUSG
		G2440B1200	S2440B1200	—
		G2440L1125CU	S2440L1125	P2440L1125CU
		G2440L1200	S2440L1200	—
		G2440L1200CU	—	P2440L1200CU
		G3030B1100CU	S3030B1100	P3030B1100CU
		G3030B1150	S3030B1150	—
		G3030B1150CU	—	P3030B1150CU
		G3030L1200	S3030L1200	—
		G3030L1200CU	—	P3030L1200CU
		G3030L1200W	S3030L1200W	—
		G3040B1200	S3040B1200	P3040B1200
		G3040B1200CP	S3040B1200P	—
		G3040B1200CU	—	P3040B1200CU
		G3040L1125CU	—	P3040L1125CU
		G3040L1125CUW	S3040L1125W	—
		G3040L1200	S3040L1200	P3040L1200
		G3040L1200CP	S3040L1200P	—
		G3040L1200CU	—	P3040L1200CU
		G3040L1200CUSG	—	P3040L1200CUSG
		G4040B1200	S4040B1200	P4040B1200
		G4040B1200CP	S4040B1200P	—
		G4040B1200CU	—	P4040B1200CU
		G4040B1200W	S4040B1200W	P4040B1200W
		G4040L1125CU	S4040L1125	P4040L1125CU
		G4040L1200	S4040L1200	P4040L1200
		G4040L1200CU	—	P4040L1200CU
		G4040L1200CUSG	—	P4040L1200CUSG
		G4242B1225CU	S4260B1225	P4260B1225CU
		G4242L1225CU	S4260L1225	P4260L1225CU
		G2020B1100SP	S2024B1100	P2024B1100CU
		G2020L1125SP	S2020L1125G	—
		G2024L1125SP	S2024L1125/S2024L1125G	P2024L1125CU
		G2424L1125SP	S2424L1125G	—
		G3030B1125CU	S3030B1125	P3030B1125CU
		G3040L1125	S3040L1125/S3040L1125G	—
		G4040B1200CUSG	—	P4040B1200CUSG

Load Centers

Cross Reference

Ultimate Load Center Cross Reference to ES Series and PL Series

Phase	Type	Current Sku	ES Series	PL Series
1 Phase	Outdoor	W0816B1200CT	SW0816B1200T	PW0816B1200TC
		W0816L1200CT	SW0816L1200T	PW0816L1200TC
		W1212L1125CU	SW1212L1125	PW1212L1125CU
		W1224B1100CU	SW1224B1100	PW1224B1100CU
		W1224L1125CU	SW1224L1125	PW1224L1125CU
		W1224L1200CU	SW1224L1200	PW1224L1200CU
		W1224L1225CU	SW1224L1225	PW1224L1225CU
		W1624B1100CU	SW1624B1100	PW1624B1100CU
		W1624L1125CU	SW1624L1125	PW1624L1125CU
		W2020B1100CU	SW2020B1100	PW2020B1100CU
		W2030L1150CU	SW2030L1150	PW2030L1150CU
		W2040B1200CU	SW2040B1200	PW2040B1200CU
		W2040L1200CU	SW2040L1200	PW2040L1200CU
		W2424L1125CU	SW2424L1125	—
		W3040B1200CU	SW3040B1200	PW3040B1200CU
		W3040L1125CU	SW3040L1125	PW3040L1125CU
		W3040L1200CU	SW3040L1200	PW3040L1200CU
		W4040B1200CU	SW4040B1200	PW4040B1200CU
		W4040L1200CU	SW4040L1200	PW4040L1200CU
		W4242B1225CU	SW4260B1225	PW4260B1225CU
W4242L1225CU	SW4260L1225	PW4260L1225CU		
3 Phase	Indoor	New	S4242B3150	—
		New – Higher Circuits	—	P5470B3225CU
		New – Higher Circuits	S5470L3225	P5470L3225CU
		G1224L3125CU	S1224L3125	P1224L3125CU
		G1224L3200CU	S1224L3200	—
		G1836L3150CU	S1836L3150	—
		G2442B3150CU	S2442B3150	P2442B3150CU
		G2442B3150CU22	—	P2442B3150CU
		G2442L3150CU	S2442L3150	—
		G2442L3200CU	S2442L3200	P2442L3200CU
		G3030B3100CU	S3030B3100	P3042B3100CU
		G3030B3100CU22	—	P3042B3100CU
		G3042B3200CU	S3054B3200	P3054B3200CU
		G3042L3200CU	S3054L3200	P3054L3200CU
		G4242B3200CU	S4260B3200	P4260B3200CU
		G4242B3225CU	S4242B3225	P4260B3225TCU/ P4260B3225CU
	G4242L3225CU	S4260L3225	P4260L3225CU	
	Outdoor	W1224L3125CU	SW1224L3125	PW1224L3125CU
		W1224L3200CU	SW1224L3200	—
		W1836L3150CU	SW1836L3150	—
		W2442B3150CU	SW2442B3150	—
		W2442L3150CU	SW2442L3150	—
		W2442L3200CU	SW2442L3200	PW2442L3200CU
		W3042B3200CU	SW3054B3200	PW3054B3200CU
		W3042B3200CU22	—	PW3054B3200CU
		W3042L3200CU	SW3054L3200	PW3054L3200CU
		W4242B3200CU	SW4260B3200	PW4260B3200CU
		W4242B3200CU22	—	PW4260B3200CU
W4242B3225CU		SW4242B3225	PW4260L3225CU	
W4242L3225CU	SW4260L3225	—		