



Thermo Scientific

TriPlus 100 Liquid Sampler

User Guide

P/N 31709702 Revision D December 2015

Thermo
SCIENTIFIC

© 2015 Thermo Fisher Scientific Inc. All rights reserved.

TriPlus 100 Liquid Sampler, TRACE 1300, TRACE 1310, TRACE GC Ultra, and FOCUS GC are trademarks of Thermo Fisher Scientific Inc., and its subsidiaries.

Published by Thermo Fisher Scientific S.p.A., Strada Rivoltana 20090 Rodano-Milan, Italy
Tel: +39 02 95059303; Fax: +39 02 95059388

Thermo Fisher Scientific Inc. provides this document to its customers with a product purchase to use in the product operation. This document is copyright protected and any reproduction of the whole or any part of this document is strictly prohibited, except with the written authorization of Thermo Fisher Scientific Inc.

The contents of this document are subject to change without notice. All technical information in this document is for reference purposes only. System configurations and specifications in this document supersede all previous information received by the purchaser.

Thermo Fisher Scientific Inc. makes no representations that this document is complete, accurate or error-free and assumes no responsibility and will not be liable for any errors, omissions, damage or loss that might result from any use of this document, even if the information in the document is followed properly.

This document is not part of any sales contract between Thermo Fisher Scientific Inc. and a purchaser. This document shall in no way govern or modify any Terms and Conditions of Sale, which Terms and Conditions of Sale shall govern all conflicting information between the two documents.

Release history:

First edition, released October 2013 "*Original Instructions*"

Second edition, June 2014; Third edition, March 2015; Fourth Edition, December 2015

For Research Use Only. Not for use in diagnostic procedures.



TriPlus 100 Liquid Sampler User Guide, PN 31709702, Fourth Edition

| | Strongly Agree | Agree | Neutral | Disagree | Strongly Disagree |
|---|-----------------------|--------------|----------------|-----------------|--------------------------|
| The manual is well organized. | 1 | 2 | 3 | 4 | 5 |
| The manual is clearly written. | 1 | 2 | 3 | 4 | 5 |
| The manual contains all the information I need. | 1 | 2 | 3 | 4 | 5 |
| The instructions are easy to follow. | 1 | 2 | 3 | 4 | 5 |
| The instructions are complete. | 1 | 2 | 3 | 4 | 5 |
| The technical information is easy to understand. | 1 | 2 | 3 | 4 | 5 |
| Examples of operation are clear and useful. | 1 | 2 | 3 | 4 | 5 |
| The figures are helpful. | 1 | 2 | 3 | 4 | 5 |
| I was able to operate the system using this manual. | 1 | 2 | 3 | 4 | 5 |

fold — — **If not, please comment below.** Attach additional sheets if necessary.

| | |
|-------|-------|
| _____ | _____ |
| _____ | _____ |
| _____ | _____ |
| _____ | _____ |
| _____ | _____ |
| _____ | _____ |
| _____ | _____ |
| _____ | _____ |

Customer Registration Card

Register now...and receive all the privileges associated with being a Thermo Fisher Scientific product user including customer support, application reports, and technical reports.

MY ORGANIZATION IS: (Check only one)

- Commercial (for profit) lab
- Government lab
- Hospital/Clinic
- Industrial lab
- Research Institute
- University/College
- Veterinary
- Other _____

MY PRIMARY APPLICATION IS: (Check only one)

- Analytical
- Biomedical
- Clinical/Toxicology
- Energy
- Environmental
- Food/Agricultural
- Forensic/Toxicology
- Pharmaceutical
- Research/Education
- Other _____

MY PRIMARY JOB FUNCTION IS: (Check only one)

- Administration
- Lab management
- Operator
- Other _____

fold — —

Name _____ Title _____
 Company _____
 Address _____
 City/State _____ Postal Code _____
 Country _____
 Telephone _____ Ext. _____
 Serial Number _____ Date purchased _____

Fold and mail or e-mail to:

Editor, Technical Publications
 Thermo Fisher Scientific S.p.A.
 Strada Rivoltana km 4
 20090 Rodano (MI)
 Italy

Editor, Technical Publications
 Thermo Fisher Scientific CMD GC-GC/MS
 2215 Grand Avenue Parkway
 Austin TX 78728-3812
 Unites States of America

Declaration

Manufacturer: **Thermo Fisher Scientific**

Thermo Fisher Scientific is the manufacturer of the instrument described in this manual and, as such, is responsible for the instrument safety, reliability and performance only if:

- installation
- re-calibration
- changes and repairs

have been carried out by authorized personnel and if:

- the local installation complies with local law regulations
- the instrument is used according to the instructions provided and if its operation is only entrusted to qualified trained personnel

Thermo Fisher Scientific is not liable for any damages derived from the non-compliance with the aforementioned recommendations.

Thermo Fisher Scientific S.p.A.

Strada Rivoltana, 20090 Rodano - Milan - Italy — Tel: +39 02 950591 - Fax: +39 02 9505276

Regulatory Compliance

Thermo Fisher Scientific performs complete testing and evaluation of its products to ensure full compliance with applicable domestic and international regulations.

Thermo Fisher Scientific declares, under sole responsibility, that the product as originally delivered complies with the requirements of the following applicable European Directives and carries the CE marking accordingly:

- Low Voltage Directive:2006/95/EC
- EMC Directive:2004/108/EC
- Machinery Directive: 2006/42/EC

... and conforms with the following product standards:

Safety

This device complies with>

- ANSI/UL 61010-1:2004 2nd Edition,
- CAN/CSA C22.2 No. 61010-1:2004 2nd Edition.
- EN 61010-2-010:2003 | EN 61010-2-051:2003 | EN 61010-2-081:2001+A1:2003 | IEC 61010-2-2101:2002

Electromagnetic Compatibility

This device complies with:

- IEC 61326-1:2nd Edition | IEC 61000-6-2:2nd Edition | IEC 61000-6-3:2nd Edition am1
- EN 55011:2009=A1:2010 | EN 61326-1:2003 | EN 61000-6-2:2005 | EN 61000-6-3:2007+ A1:2011
- CISPR 11:5th Edition am1

Laser Class 1

The selected Class 1 Laser for the module Barcode Reader of the TriPlus 100 Liquid Sampler system complies with the following regulations:

- 21 CFR1040.10 and 1040.11 except for deviations pursuant to Laser Notice No. 50, dated July 26, 2001
- EN60825-1:1994 + A1:2002 + A2:2001
- IEC60825-1:1993 + A1:1997 + A2:2001

FCC Compliance Statement

Thermo Fisher Scientific hereby declares that our product has been tested and complies with the requirements of FCC Part 15 Subpart B (Class B).

THIS DEVICE COMPLIES WITH PART 15 OF THE FCC RULES. OPERATION IS SUBJECT TO THE FOLLOWING TWO CONDITIONS: (1) THIS DEVICE MAY NOT CAUSE HARMFUL INTERFERENCE, AND (2) THIS DEVICE MUST ACCEPT ANY INTERFERENCE RECEIVED, INCLUDING INTERFERENCE THAT MAY CAUSE UNDESIRE OPERATION.



CAUTION Read and understand the various precautionary notes, signs, and symbols contained inside this manual pertaining to the safe use and operation of this product before using the device.

Notice on Lifting and Handling of Thermo Scientific Instruments

For your safety, and in compliance with international regulations, the physical handling of this Thermo Fisher Scientific instrument *requires a team effort* to lift and/or move the instrument. This instrument is too heavy and/or bulky for one person alone to handle safely.

Notice on the Proper Use of Thermo Scientific Instruments

In compliance with international regulations: Use of this instrument in a manner not specified by Thermo Fisher Scientific could impair any protection provided by the instrument.

Notice on the Susceptibility to Electromagnetic Transmissions

Do not use radio frequency transmitters, such as mobile phones, in close proximity to the instrument.

WEEE Compliance

This product is required to comply with the European Union's Waste Electrical & Electronic Equipment (WEEE) Directive 2012/19/EU. It is marked with the following symbol:



Thermo Fisher Scientific has contracted with one or more recycling or disposal companies in each European Union (EU) Member State, and these companies should dispose of or recycle this product. See www.thermoscientific.com/rohswcee for further information on Thermo Fisher Scientific's compliance with these Directives and the recyclers in your country.

WEEE Konformität

Dieses Produkt muss die EU Waste Electrical & Electronic Equipment (WEEE) Richtlinie 2012/19/EU. erfüllen. Das Produkt ist durch folgendes Symbol gekennzeichnet:



Thermo Fisher Scientific hat Vereinbarungen mit Verwertungs-/Entsorgungsfirmen in allen EU-Mitgliedsstaaten getroffen, damit dieses Produkt durch diese Firmen wiederverwertet oder entsorgt werden kann. Mehr Information über die Einhaltung dieser Anweisungen durch Thermo Fisher Scientific, über die Verwerter, und weitere Hinweise, die nützlich sind, um die Produkte zu identifizieren, die unter diese RoHS Anweisung fallen, finden sie unter www.thermoscientific.com/rohswcee.

Conformité DEEE

Ce produit doit être conforme à la directive européenne (2012/19/EU) des Déchets d'Equipements Electriques et Electroniques (DEEE). Il est marqué par le symbole suivant:



Thermo Fisher Scientific s'est associé avec une ou plusieurs compagnies de recyclage dans chaque état membre de l'union européenne et ce produit devrait être collecté ou recyclé par celles-ci. Davantage d'informations sur la conformité de Thermo Fisher Scientific à ces directives, les recycleurs dans votre pays et les informations sur les produits Thermo Fisher Scientific qui peuvent aider la détection des substances sujettes à la directive RoHS sont disponibles sur www.thermoscientific.com/rohswcee.

Conformità RAEE

Questo prodotto è marcato con il seguente simbolo in conformità alla direttiva europea 2012/19/EU (RAEE) sui rifiuti di apparecchiature elettriche ed elettroniche:



Thermo Fisher Scientific si è accordata con una o più società di riciclaggio in ciascun Stato Membro della Unione Europea (EU), e queste società dovranno smaltire o riciclare questo prodotto. Per maggiori informazioni vedere il sito www.thermoscientific.com/rohsweee.

Conformidad RAEE

Este producto es marcado con el siguiente símbolo en conformidad a la Directiva 2012/19/EU de la Unión Europea sobre los residuos de aparatos eléctricos y electrónicos:



Thermo Fisher Scientific ha contratado una o más empresas de reciclaje para tratar residuos en cada Estado Miembro de la Unión Europea, y estas empresas deberían reciclar o eliminar este producto. Referirse a www.thermoscientific.com/rohsweee para una mayor información sobre la conformidad de Thermo Fisher Scientific con estas Directivas y para las empresas de reciclaje en su país.



IMPORTANT

The symbol indicates the product must not be disposed of with the normal household wastes. Correct disposal of this product prevents any potentially negative impact on the environmental and human health that could arise from any inappropriate handling of the product itself.

WEEE and RoHS rules, while laid down at European level, are put into national law at national level. When exporting to Europe, it is essential to comply with national law in each relevant country. The EU law simply serves as a template for national laws, which may differ considerably.

Each EU Member State has own regulations regarding the application of these directives. Please refer to the regulations in force in your country.

| | |
|--|-------------|
| Preface | xiii |
| About Your System | xiv |
| Power Rating | xiv |
| Contacting Us | xiv |
| Related Documentation | xiv |
| Safety Alerts and Important Information | xv |
| Special Notices | xv |
| Safety Symbols and Signal Words | xv |
| Instrument Markings and Symbols | xvii |
| Safety Information and Warnings | xviii |
| General Considerations | xviii |
| Electrical Hazards | xix |
| Laser Safety Information | xx |
| Other Hazards | xxi |
| Working with Toxic or other Harmful Compounds | xxiii |
| Biological Hazards | xxiii |
| Maintenance | xxiv |
| Disposal | xxiv |
| | |
| Chapter 1 Getting Familiar with Your TriPlus 100 Liquid Sampler | 1 |
| Instrument Basics | 2 |
| Definition of Terms, Naming Conventions, and Start Screen Icons | 2 |
| Definition of Terms | 2 |
| Naming Conventions | 5 |
| Start Screen Icons | 6 |
| The TriPlus 100 Liquid Sampler System | 8 |
| Sampling Unit | 8 |
| Modules | 9 |
| Optional Modules | 10 |
| Power Module | 10 |
| User Interface | 10 |
| Crossrails | 10 |
| Crossrail X | 11 |
| Crossrail Y | 11 |
| Head | 12 |
| Syringe Adapter | 13 |
| Syringes | 13 |
| Control Interface | 14 |
| Definitions of Active and Passive Hardware Modules | 16 |
| Active Versus Passive Module | 16 |
| Active Versus Composite Module | 17 |
| Modules Description and Specifications | 18 |
| Standard Wash Station | 19 |
| Large Volume Wash Station | 20 |
| Large Solvent Station | 20 |

| | |
|--|-----------|
| Fast Wash Station | 21 |
| Agitator | 22 |
| Vortexer | 24 |
| Barcode Reader | 26 |
| Safety Information | 27 |
| Supported Types of Barcode Symbols | 27 |
| Approved Barcode Labels | 29 |
| Barcode Label Positioning | 29 |
| Reading the Barcode from a Vial or Well Plate | 29 |
| Multidimensional Barcodes | 30 |
| Barcode Label Size | 30 |
| Barcode Reader Specifications | 30 |
| Standard Tray Holder | 31 |
| Liquid Cooled Tray Holder | 32 |
| Temperature Controlled Drawer | 33 |
| Temperature Control | 34 |
| Temperature Alarm | 35 |
| Temperature Stability | 35 |
| Condensation Build-up | 35 |
| Safety Warning | 35 |
| Temperature Controlled Drawer Specifications | 36 |
| Handheld Controller (Terminal) | 38 |
| Menu Screen | 38 |
| Menu Screen Status Bar Symbols | 39 |
| Function Keys and Buttons | 40 |
| Scroll Wheel and Enter Button | 41 |
| Handheld Controller Versus the Virtual Handheld Controller | 41 |
| Chapter 2 TriPlus 100 Liquid Sampler Basic Information | 43 |
| Starting the TriPlus 100 Liquid Sampler System | 44 |
| How to Start the TriPlus 100 Liquid Sampler System | 44 |
| Short-cuts from Startup Screen | 46 |
| Access Levels | 47 |
| User Level | 47 |
| Extended User Level | 48 |
| Service Level | 49 |
| Changing Access Level | 49 |
| Example of Differences in Access Levels | 52 |
| Setup, Installation, and Maintenance Menu Item | 52 |
| Help Menu Item | 53 |
| About Menu Item | 53 |
| Shutdown Menu Item | 53 |
| Operation of the TriPlus System in Combination with Other Chromatography Data Systems | 54 |

| | | |
|------------------|---|------------|
| Chapter 3 | Setup Menu Item | 55 |
| | Starting Setup Menu Item | 56 |
| | Setup Menu Item Modules | 57 |
| | Agitator | 59 |
| | Vortexer | 63 |
| | Barcode Reader | 64 |
| | Chromatograph System | 66 |
| | Input/Output Interface | 67 |
| | Injectors | 70 |
| | Motors | 72 |
| | Obstacle | 74 |
| | Sample Drawers | 76 |
| | Signals | 80 |
| | Solvent Stations | 83 |
| | Syringe Types | 85 |
| | Tray Holders | 87 |
| | Tray Types | 90 |
| | Trays | 99 |
| | Vial Types | 102 |
| | Vials | 104 |
| | Wash Stations | 108 |
| | Tray Slots | 114 |
| | Unknown | 114 |
| | Setup Menu Item - Set Date and Time | 115 |
| | Setup Menu Item - Set TriPlus 100 Liquid Sampler Name | 116 |
| | Setup Menu Item - Setup Network | 116 |
| Chapter 4 | Maintenance Menu Items | 119 |
| | Maintenance Menu | 120 |
| | Check Teaching Module | 121 |
| | Check Configuration | 121 |
| | Reset Configuration | 122 |
| | Create Diagnostic Backup | 122 |
| | Create Configuration Backup | 123 |
| | Copy Backup | 124 |
| | Restore Backup | 124 |
| Chapter 5 | Service Menu Item | 127 |
| | Service Menu | 128 |
| | Prerequisites | 128 |

Contents

| | |
|--|------------|
| Installation Item | 129 |
| Set Regional Settings | 131 |
| Set Date and Time | 132 |
| Set TriPlus Name | 134 |
| Setup Network | 135 |
| Calibrate Motors | 138 |
| Teach Exchange Position | 139 |
| Setup Module | 140 |
| Teach Module | 141 |
| Check Teaching Modules | 145 |
| Exchange Syringe | 146 |
| Create a Configuration Backup File | 147 |
| Create New Tray System Item | 148 |
| Chapter 6 Analytical Troubleshooting | 151 |
| General Points Regarding Chromatographic Effects | 152 |

Preface

This manual describes the features and the components of the Thermo Scientific™ TriPlus™ 100 Liquid Sampler system. Inside, you will find all of the information necessary for the routine operations of your sampling system. These include operating procedures, sample injection techniques, diagrams, and the description of the major components.

This User Guide is intended for frequent or new TriPlus 100 Liquid Sampler system users who are experienced at using automated systems to run existing analytical methods.

Note The TriPlus 100 Liquid Sampler system must be installed and set up properly before the Operating Instructions can be used.

This manual is organized as follows:

- [Chapter 1, “Getting Familiar with Your TriPlus 100 Liquid Sampler,”](#) provides information to familiarize you with the TriPlus 100 Liquid Sampler system.
- [Chapter 2, “TriPlus 100 Liquid Sampler Basic Information,”](#) provides basic information for starting the TriPlus 100 Liquid Sampler system, and for using the Handheld Controller.
- [Chapter 3, “Setup Menu Item,”](#) describes the options of the **Setup Menu** operated either with the Virtual Handheld Controller, or directly using the installed Handheld Controller.
- [Chapter 4, “Maintenance Menu Items,”](#) describes the options of the **Maintenance Menu** operated either with the Virtual Handheld Controller, or directly using the installed Handheld Controller.
- [Chapter 5, “Service Menu Item,”](#) describes the options of the **Service Menu** operated either with the Virtual Handheld Controller or directly using the installed Handheld Controller.
- [Chapter 6, “Analytical Troubleshooting,”](#) gives a quick overview of possible causes and recommended actions which can be taken to eliminate an erratic behavior.

About Your System

Thermo Fisher Scientific systems operate safely and reliably under carefully controlled environmental conditions. If the equipment is used in a manner not specified by the manufacturer, the protections provided by the equipment might be impaired. If you maintain a system outside the specifications listed in this guide, failures of many types, including personal injury or death, might occur. The repair of instrument failures caused by operation in a manner not specified by the manufacturer is specifically excluded from the Standard Warranty and service contract coverage.

Power Rating

TriPlus 100 Liquid Sampler system:

100/240 Vac +/-10%; 50/60 Hz; 5 A max; 200 VA (400 VA when two Power Modules are required).

Detailed instrument specifications are in the Product Specification or Product Brochure.

Contacting Us

Thermo Fisher Scientific provides comprehensive technical assistance worldwide and is dedicated to the quality of our customer relationships and services.

Use <http://www.thermoscientific.com> address for products information.

Use <http://www.gc-gcms-customersupport.com/WebPage/Share/Default.aspx> address to contact your local Thermo Fisher Scientific office, or affiliate GC-GC/MS Customer Support.

Related Documentation

In addition to this guide, Thermo Scientific provides the following documents for the TriPlus 100 Liquid Sampler system.

- *TriPlus 100 Liquid Sampler Preinstallation Requirements Guide*, PN 31709701
- *TriPlus 100 Liquid Sampler Hardware Manual*, PN 31709703
- *TriPlus 100 Liquid Sampler Spare Parts Guide*, PN 31709704

To suggest ways we can improve the documentation, follow this link to complete our [documentation survey](#).

Safety Alerts and Important Information

Make sure you follow the precautionary notices presented in this manual. The safety and other special notices appear in boxes.

Special Notices

Notices includes the following:





IMPORTANT Highlights information necessary to prevent damage to software, loss of data, or invalid test results; or might contain information that is critical for optimal performance of the system.

Note Emphasizes important information about a task.

Tip Helpful information that can make a task easier.

Safety Symbols and Signal Words

All safety symbols are followed by **WARNING** or **CAUTION**, which indicates the degree of risk for personal injury, instrument damage, or both. Cautions and warnings are following by a descriptor, such as **BURN HAZARD**. A **WARNING** is intended to prevent improper actions that could cause personal injury. Whereas, a **CAUTION** is intended to prevent improper actions that might cause personal injury, instrument damage, or both. You can find the following safety symbols on your instrument, or in this guide:

| Symbol | Descriptor |
|---|--|
|  | BIOHAZARD: Indicates that a biohazard <i>will, could, or might</i> occur. |
|  | BURN HAZARD: Alerts you to the presence of a hot surface that <i>could or might</i> cause burn injuries. |
|  | ELECTRICAL SHOCK HAZARD: Indicates that an electrical shock <i>could or might</i> occur. |
|  | FIRE HAZARD: Indicates a risk of fire or flammability <i>could or might</i> occur. |
|  | EXPLOSION HAZARD. Indicates an explosion hazard. This symbol indicates this risk <i>could or might</i> cause physical injury. |

| | |
|---|---|
|  | <p>FLAMMABLE GAS HAZARD. Alerts you to gases that are compressed, liquefied or dissolved under pressure and can ignite on contact with an ignition source. This symbol indicates this risk <i>could</i> or <i>might</i> cause physical injury.</p> |
|  | <p>GLOVES REQUIRED: Indicates that you must wear gloves when performing a task or physical injury <i>could</i> or <i>might</i> occur.</p> |
|  | <p>CLOTHING REQUIRED. Indicates that you should wear a work clothing when performing a task or else physical injury <i>could</i> or <i>might</i> occur.</p> |
|  | <p>BOOTS REQUIRED. Indicates that you must wear boots when performing a task or else physical injury <i>could</i> or <i>might</i> occur.</p> |
|  | <p>MATERIAL AND EYE HAZARD. Indicates you must wear eye protection when performing a task.</p> |
|  | <p>HAND AND CHEMICAL HAZARD: Indicates that chemical damage or physical injury <i>could</i> or <i>might</i> occur.</p> |
|  | <p>HARMFUL. Indicates that the presence of harmful material <i>will, could, or might</i> occur.</p> |
|  | <p>INSTRUMENT DAMAGE: Indicates that damage to the instrument or component <i>might</i> occur. This damage might not be covered under the standard warranty.</p> |
|  | <p>LIFTING HAZARD. Indicates that a physical injury <i>could</i> or <i>might</i> occur if two or more people do not lift an object.</p> |
|  | <p>MATERIAL AND EYE HAZARD: Indicates that eye damage <i>could</i> or <i>might</i> occur.</p> |
|  | <p>READ MANUAL: Alerts you to carefully read your instrument's documentation to ensure your safety and the instrument's operational ability. Failing to carefully read the documentation <i>could</i> or <i>might</i> put you at risk for a physical injury.</p> |
|  | <p>TOXIC SUBSTANCES HAZARD: Indicates that exposure to a toxic substance could occur and that exposure <i>could</i> or <i>might</i> cause personal injury or death.</p> |
|  | <p>LASER HAZARD. Indicates that exposure to a laser beam <i>will, could, or might</i> cause personal injury.</p> |



RADIOACTIVE HAZARD. Indicates that the presence of radioactive material *could or might* occur.



For the prevention of personal injury, this general warning symbol precedes the **WARNING** safety alert word and meets the ISO 3864-2 standard. In the vocabulary of ANSI Z535 signs, this symbol indicates a possible personal injury hazard exists if the instrument is improperly used or if unsafe actions occur. This symbol and another appropriate safety symbol alerts you to an imminent or potential hazard that *could cause personal injury*.





Instrument Markings and Symbols

Table 1 explains the symbols used on Thermo Fisher Scientific instruments. Only a few of them are used on the TriPlus 100 Liquid Sampler system. See the asterisk.

Table 1. Instrument Marking and Symbols (Sheet 1 of 2)

| Symbol | Description |
|--------|--|
| | Direct Current |
| * | Alternating Current |
| | Both direct and alternating current |
| 3 | Three-phase alternating current |
| | Earth (ground) terminal |
| | Protective conductor terminal |
| | Frame or chassis terminal |
| | Equipotentiality |
| * | On (Supply) |
| * | Off (Supply) |
| | Equipment protected throughout by DOUBLE INSULATION or REINFORCED INSULATION (Equivalent to Class II of IEC 536) |
| | Fuse |
| * | Instruction manual symbol affixed to product. Indicates that the you must refer to the manual for specific WARNING or CAUTION information to avoid personal injury or damage to the product. |

Table 1. Instrument Marking and Symbols (Sheet 2 of 2)

| Symbol | Description |
|---|--|
|  | Caution, risk of electric shock |
| *  | Caution, hot surface |
| *  | Caution, biohazard |
| *  | Caution, Laser beam |
| *  | Symbol in compliance to the Directive 2012/19/EU on Waste Electrical and Electronic Equipment (WEEE) placed on the European market after August, 13, 2005. |

Safety Information and Warnings

This safety guide raises awareness of potential safety issues and general points for consideration for Thermo Fisher Scientific representatives during installation, and repair of the TriPlus 100 Liquid Sampler system, or parts of it (following the life cycle principle), as well as for the end user TriPlus 100 Liquid Sampler system in the lab during the learning phase, and in routine work.



IMPORTANT Read this section first before operating the TriPlus 100 Liquid Sampler system.

General Considerations

- Before a unit is put to use, consult the *TriPlus 100 Liquid Sampler User Guide* and related documents under all circumstances.
- Changes or modifications to this unit not expressly approved by the party responsible for compliance, could void your’s authority to operate the equipment.
- Be aware that if the equipment is used in a manner not specified by the manufacturer, the protective and safety features of the equipment might be impaired.
- The repair of instrument failures caused by operation in a manner not specified by the manufacturer is expressly excluded from the standard warranty and service contract coverage.
- When for technical reasons it is necessary to work on instrument parts which might involve a potential hazard (moving parts, components under voltage, and so on.) contact the Thermo Fisher Scientific authorized representative.

In general, this type of situation arises when access to the parts is only possible using a tool. When you perform a maintenance operation, you must have received proper training to carry out that specific task.

Electrical Hazards



Every analytical instrument has specific hazards. Be sure to read and comply with the following pre-cautions. They ensure the safe and long-term use of your TriPlus 100 Liquid Sampler system.

The installation over-voltage category is Level II. The Level II category pertains to equipment receiving its electrical power from the local level, such as an electrical wall outlet.

Connect the TriPlus 100 Liquid Sampler system only to instruments complying with IEC 61010 safety regulations.

The power line and the connections between the TriPlus 100 Liquid Sampler system and other instruments, used in the configuration setup of the total analytical system, must maintain good electrical grounding. Poor grounding represents a danger for the operator, and might seriously affect the performance of the instrument.

Do not connect the TriPlus 100 Liquid Sampler system to power lines that supply devices of a heavy duty nature, such as motors, refrigerators and other devices that can generate electrical disturbances.



Use only fuses of the type and current rating specified. Do not use repaired fuses, and do not short-circuit the fuse holder. The supplied power cord must be inserted into a power outlet with a protective earth (ground) contact. When using an extension cord, make sure that the cord also has an earth contact.

If the supplied power cord does not fit the local electrical socket and a replacement or adapter has to be purchased locally, make sure that only a certified power cord is used. Any power cord used must be certified by the appropriate local authorities.

Pay attention not to leave any cable connecting the TriPlus 100 Liquid Sampler system and the chromatographic system, or the power cord close to heated zone, such as the injector or detector heating blocks, or the GC hot air vents.

Always replace any cable showing signs of damage with another one provided by the manufacturer. Safety regulations must be respected.



Do not change the external or internal grounding connections. Tampering with or disconnecting these connections could endanger you and damage the TriPlus 100 Liquid Sampler system.

The instrument is properly grounded in accordance with these regulations when shipped. To ensure safe operation, you do not must make any changes to the electrical connections or the instrument's chassis.

Preface

Safety Information and Warnings



Do not turn the instrument on if you suspect that it has incurred any type of electrical damage. Instead, disconnect the power cord and contact a Thermo Fisher Scientific representative for a product evaluation. Do not attempt to use the instrument until it has been evaluated. Electrical damage might have occurred if the TriPlus 100 Liquid Sampler system shows visible signs of damage, exposure to any liquids or has been transported under severe stress.



Damage can also result if the instrument is stored for prolonged periods under unfavorable conditions: for example, subjected to heat, moisture, and so on. Ensure that the power supply/controller unit is always placed in a clean and dry position. Avoid any liquid spills in the vicinity.



Before attempting any type of maintenance work, always disconnect the power cords from the power supply if optional devices are installed. Capacitors inside the instrument might still be charged also if the instrument is turned off.

To avoid damaging electrical parts, do not disconnect an electrical assembly while power is applied to the TriPlus 100 Liquid Sampler system. After the power is turned off, wait approximately 30 seconds before you disconnect an assembly.



The instrument includes a number of integrated circuits. These circuits might be damaged if exposed to excessive line voltage fluctuations, power surges or electrostatic charges, or both.



Never try to repair or replace any components of the instrument without the assistance of a Thermo Fisher Scientific representative. There are no operator-serviceable or replaceable parts inside the power supply or in the TriPlus 100 Liquid Sampler system. If a power supply is not functioning, contact a Thermo Fisher Scientific representative.



The power supplies for the TriPlus 100 Liquid Sampler system, the Temperature Controlled Drawer have the symbols **I/O** on the label for the power switch to indicate ON/OFF. If a Temperature Controlled Drawer is installed in combination with a TriPlus 100 Liquid Sampler system, a second power supply is active in the complete system. Turning OFF the two power supplies, or pulling the two power cords in an emergency, stop the entire TriPlus 100 Liquid Sampler system.

It is important that the power supply is in a location where the power ON/OFF switch is accessible and easy to operate, and where it is possible to unplug the AC power cord from the power supply/wall outlet in case of emergency.

Laser Safety Information



Safety Warning for Laser Class 1 Product.

CLASS 1 LASER PRODUCT
LASER KLASSE 1
APPAREIL À LASER DE CLASSE 1



WARNING The installed Laser device is a Class 1 Laser Product. Class 1 Laser devices are not considered to be hazardous when used for their intended purpose. The following statement is required to comply with US and international regulations:

CAUTION Use of controls, adjustments or performance of procedures other than those specified herein might result in hazardous laser light exposures.

- The selected Class 1 Laser for the TriPlus 100 Liquid Sampler system module Barcode Reader complies with the following regulations:
- 21 CFR1040.10 and 1040.11 except for deviations pursuant to Laser Notice No. 50, dated July 26, 2001
- EN60825-1:1994 + A1:2002 + A2:2001
- IEC60825-1:1993 + A1:1997 + A2:2001

The software contains a built-in safety time limit such that the laser scanning mechanism cannot be operated in AIM mode for more than 5 continuous seconds.

Other Hazards



To avoid injury and possible infection through contamination during TriPlus 100 Liquid Sampler system operation, keep your hands away from the syringe.



Do not operate the TriPlus 100 Liquid Sampler system without the safety guard. The safety guard must be installed for safe operation. Do not place any objects inside the area of the safety guard. Keep away from the area around the safety guard during operation of the TriPlus 100 Liquid Sampler system.



Danger of crushing to fingers and hands. To avoid injury keep your hands away from moving parts during operation. Turn off the power to the TriPlus 100 Liquid Sampler system if you must reach inside a mechanically powered system with moving parts.



To avoid injury, observe safe laboratory practice when handling solvents, changing tubing, or operating the TriPlus 100 Liquid Sampler system. Know the physical and chemical properties of the solvents you use. See the MSDS (Material Safety Data Sheets) from the manufacturer of the solvents being used.

When using the TriPlus 100 Liquid Sampler system, follow the generally accepted procedures for quality control and method development.

When using the TriPlus 100 Liquid Sampler system in the field of chromatographic analysis, if a change is observed in the retention of a particular compound, in the resolution between two compounds, or in the peak shape, immediately determine the reasons for the changes. Do not rely on the separation results until you determine the cause of a change.

Do not operate on the instrument components that form part of the work area of the TriPlus 100 Liquid Sampler system when it is in motion.



Use caution when working with any polymer tubing under pressure:

- Always wear eye protection when near pressurized polymer tubing.
- Do not use polymer tubing that has been severely stressed or kinked.
- Do not use polymer tubing, in particular no PEEK or Tefzel tubing when using tetrahydrofuran (THF), dimethylsulfoxide (DMSO), chlorinated organic solvents, concentrated mineral acids such as nitric, phosphoric or sulfuric acids, or any related compounds.



In case of a single fault situation where the temperature control of the Agitator fails, there is the potential danger that the device will heat up in an uncontrolled manner until it reaches the cut-off temperature of the over temperature fuse, in this case, 240 °C. Based on this single fault scenario, when working with flammable solvents, ensure that the solvent used has a flash point which is 25 °C higher than the maximum potential temperature (240 °C) of the Agitator.



Do not use vials without a sealing cap, or microtiter or deepwell plates without a plate seal. Vapor phase from organic solvents can be hazardous and flammable. Acidic vapor phase can cause corrosion to critical mechanical parts.



When sample vials have to undergo heating and agitation, it is important to consider the glass quality. Use high quality glass only. Remember that depending on the application conditions, high pressure can build up in the vial. Whenever a temperature greater than 60 °C is applied, consider the vapor pressure of the solvent used to ensure that no excessive pressure builds up. This is important when using a temperature above 100 °C and especially at the maximum temperature of 200 °C. Be aware that solid materials can also contain volatile compounds such as water (humidity) which could cause build-up of excess vapor pressure.

Do not reuse the vials. During the process of washing the vial, micro-cracks can form which will weaken the glass wall and increase the chances of the vial breaking.



When filling-up a standard reservoir or replacing a solvent such as a washing solvent, remove the solvent reservoir bottle from the system to avoid a possible spill over the instrument. Depending on the physical, chemical or hazardous properties of the solvent, use the appropriate protective measures for handling.

Working with Toxic or other Harmful Compounds



WARNING Before using hazardous substances (toxic, harmful, and so on), please read the hazard indications and information reported in the applicable Material Safety Data Sheet (MSDS). Use personal protective equipment according to the safety requirements.

Before using dangerous substances (toxic, harmful, and so on) read the hazard indications and information reported in the Material Safety Data Sheet (MSDS) supplied by the manufacturer, referring to the relevant CAS (Chemical Abstract Service) number. The TriPlus 100 Liquid Sampler system requires the use of several chemical products with different hazard characteristics, which are present in vials and syringes. Before using these substances or replacing the syringe, please read the hazard indications and information reported in the MSDS supplied by the manufacturer referring to the relevant CAS number.

When preparing the samples, please refer to local regulations for the ventilation conditions of the work room.

All waste materials must be collected and eliminated in compliance with the local regulations and directives in the country where the instrument is used.

Biological Hazards



In laboratories where samples with potential biological hazards are handled, you must label any equipment or parts thereof which might become contaminated with biohazardous material. The appropriate warning labels are included with the shipment of the instrument. It is your responsibility to label the relevant parts of the instrument.

When working with biohazardous materials, it is your responsibility to fulfill the following mandatory requirements:

- Instructions on how to safely handle biohazardous material must be provided.
- Operators must be trained and made aware of the potential dangers.
- Personal protective equipment must be provided.
- Instructions must be provided on what to do in case operators are exposed to aerosols or vapors during normal operation (within the intended use of the equipment) or in case of single fault situations such as a broken vial.
The protective measures must consider potential contact with the skin, mouth, nose (respiratory organs), and eyes.
- Instructions for decontamination and safe disposal of the relevant parts must be provided.

It is your responsibility to handle hazardous chemicals or biological compounds (including, but not limited to, bacterial or viral samples and the associated waste), safely and in accordance with international and local regulations.

Maintenance

Any external cleaning or maintenance must be performed with the TriPlus 100 Liquid Sampler system turned off and the power cord disconnected. Avoid using solvents and spraying on electrical parts. For the removal of potentially dangerous substances (toxic, harmful, and so on) read the hazard indications and information reported in the MSDS (Material Safety Data Sheet) supplied by the manufacturer referring to the relevant CAS (Chemical Abstract Service) number. Use proper protective gloves.

When working with hazardous materials such as radioactive, biologically hazardous material, and so on, it is important to train all operators how to respond in case of spills or contamination.

Depending on the class of hazardous material, the appropriate measures have to be taken immediately. Therefore, the chemicals or solvents needed for decontamination have to be on hand.

Any parts of the equipment which can potentially be contaminated, such as the sample vial rack, syringe tool, wash module, and so on, must be cleaned regularly. The waste solvent from cleaning and any hardware which requires to be disposed of has to be properly eliminated with all the necessary precautions, abiding by national and international regulations.

When preparing for decontamination, ensure that the solvent or chemical to be used will not damage or react with the surface, dye (color) of the instrument, table or other nearby objects. If in doubt, please contact your Thermo Fisher Scientific representative to verify the compatibility of the type or composition of solvents with the TriPlus 100 Liquid Sampler system.

It is your responsibility to handle hazardous chemicals or biological compounds, including (but not limited to) bacterial or viral samples and the associated wastes, safely and in accordance with international and local regulations.

Disposal



Do not dispose of this equipment or parts thereof unsorted in municipal waste. Follow local municipal waste regulations for proper disposal provisions to reduce the environmental impact of waste electrical and electronic equipment (WEEE).

European Union customers: Call your local customer service representative responsible for the TriPlus 100 Liquid Sampler system for complimentary equipment pick-up and recycling.

WARNING The customer has to ensure that the TriPlus 100 Liquid Sampler system has not been contaminated by any hazardous chemical or biological compounds including (but not limited to) bacteria or viruses.



Any part which had direct contact with the analytical sample must be identified and must undergo an appropriate decontamination procedure prior to shipping for disposal.

Potentially dangerous components are: Syringes, Vials and Well Plates. Any critical parts sent for disposal must be handled according to national laws for hazardous compounds.

The customer and the service engineer are fully responsible for enforcing these requirements. Thermo Fisher Scientific will hold the representative, customer responsible, or both, if these regulations are not observed.

Preface

Safety Information and Warnings

Getting Familiar with Your TriPlus 100 Liquid Sampler

This chapter provides information to familiarize you with the TriPlus 100 Liquid Sampler system.

Contents

- Instrument Basics
- Definition of Terms, Naming Conventions, and Start Screen Icons
- The TriPlus 100 Liquid Sampler System
- Crossrails
- Head
- Syringe Adapter
- Syringes
- Control Interface
- Definitions of Active and Passive Hardware Modules
- Modules Description and Specifications
- Standard Wash Station
- Large Volume Wash Station
- Large Solvent Station
- Fast Wash Station
- Agitator
- Vortexer
- Barcode Reader
- Standard Tray Holder
- Liquid Cooled Tray Holder
- Temperature Controlled Drawer
- Handheld Controller (Terminal)

Instrument Basics

The TriPlus Liquid Sampler is dedicated to the single technique of injecting liquid samples. The instrument operates with Firmware version 2.0 or higher.

The basic configuration consists of the following parts:

- Base: X-,Y-Axis with built-in electronic and control, with basic Firmware loaded.
- Head: Entire unit with complete Z-Axis and Head Cover installed.
- Power Supply including power cable (AC) and DC cable.
- Wash Station: the type varies according to the instrument configuration.
- Tray Holder.
- Optional Terminal (Handheld Controller) including Terminal Holder.

Definition of Terms, Naming Conventions, and Start Screen Icons

This section details the definition of the terms, the naming conventions used in this manual, and the start screen icons visualized on the Handheld Controller.

See the related topics:

- [“Definition of Terms”](#) on page 2
- [“Naming Conventions”](#) on page 5
- [“Start Screen Icons”](#) on page 6

Definition of Terms

- **TriPlus 100 Liquid Sampler** — The brand name for the entire system product family. The product family includes not only the TriPlus 100 Liquid Sampler system but also the various optional modules.
- **Module** — A generic term used to refer to both active and passive modules.
- **Active Module** — A module that is controlled by the BUS connector via active control. An active module requires a device firmware. An active module is recognized when connected to the BUS, it can be de-activated but not deleted.
- **Passive Module** — A static module, e.g. a non-temperature programmable tray holder, does not require any control or checks through the BUS. A passive module requires an object template. A specific device firmware is not required. A passive module cannot be deactivated but it can be deleted.

- **Composite Module** — An active module consisting of one or more devices which also communicate with the BUS, but in slave functionality. A typical example is the Head (Z-axis).
- **Device** — A single active module communicating with the BUS but in slave functionality. Each device requires a device firmware.
- **Motor** — Generic term for the new generation of motors used for the axes. The motor uses the logic of a servo-motor with electronic and software control. The various motors are specified with the suffix of where the motor is applied, such as motor-X, or motor-Z.
- **Base** — The combination of the X- and Y-Axes, with or without the electronics installed.
- **Head** — Consist of Z-axis, the Needle Guide Motor, and the Plunger Motor. The cover is part of the entire unit as well.
- **Syringe Adapter** — Generic term for the holder of a syringe for liquid samples.
- **Firmware** — The entire software package of the operating system, application software, configuration, and various device firmware. The file extension is ***.pack**.
- **Device Firmware** — The software for an active module.
- **Activity** — The lowest level of command available with the Firmware. Activities depend on the Firmware (Application Software) version, and are downloaded to the program from the TriPlus 100 Liquid Sampler system when the initial connection is made, and updated during the run time on a regular basis.

Activities are grouped in classes:

- **Public:** Activities available to build a custom specific script.
- **Private:** Activities not available to build a script. They are necessary for internal control, and for the integration of the TriPlus 100 Liquid Sampler system into another Chromatography Data System (CDS).

A Script is built by linking **Activities** together in a sequence.

- **Script** — Created by building a sequence of the operations of the TriPlus 100 Liquid Sampler system, which are linked by a series of Activities. A Script can be a Method depending on the functionality built-into the script.
- **Cycle** — Consists of the specific operations necessary to process one sample. The cycle operations are repeated for each sample within a job (sequence). Cycles are designed for specific applications.
- **Method** — Defines how the samples are processed. The elements of a method are a cycle, a syringe, and a parameter list. Methods have names with up to eight characters and can be edited, copied, and deleted.

1 Getting Familiar with Your TriPlus 100 Liquid Sampler

Definition of Terms, Naming Conventions, and Start Screen Icons

- **Method Parameters** — Associated with the cycle operations. User-assigned parameter values define how a processing operation is performed. A zero parameter value will disable a cycle operation. Cycle parameters are application-specific.
- **Objects** — Data structures describing the properties of physical modules, such as Tray Holder, Agitator, Motors, and so on.
- **Module Type** — Unique identification of a module, defines the machine object description of the combining device.
- **Module ID** — Unique identification of a module.
- **Tray Holder** — Holds one or more trays. Each tray holder has a reference position (X-, Y-, Z-coordinates), that defines its location. A tray holder is a passive module.
- **Slot** — The physical place where a Tray can be positioned in the Tray Holder.
- **Sample Tray** — Generic term. A tray can be a **rack** for holding vials, or a well plate for deepwell plates, or microtiter plates. A tray holds multiple samples. Trays are defined by designating the tray type, and the Tray Holder. Tray names are used to identify the sample source within a Job.
- **Well Plate** — A generic term used for all types of well plates. The most common well Plates are deepwell plates, or microtiter plates. The well plates have a standardized footprint. The tray holder drawers are designed to accept well plates. Passive tray holders for the TriPlus 100 Liquid Sampler system have three slots, each one designed with the footprint dimensions of a Well Plate.
- **Tray Type** — Generic term. A Tray Type can be a Tray for vials or a plate for well plates. A Tray Type defines the pattern and sampling sequence of sample locations within a Tray.
- **Vial Type** — The physical dimensions of a Vial and parameters required for automation, such as Needle Penetration Depth or Penetration Speed, are described by the various item parameters of the Vial Type.
- **Cap Type** — Describes the material of the vial cap, which in turn determines whether or not a vial can be transported.
- **Needle Guide Type** — Selectable parameter in the software class **Tools**. Selects the required tool that is mounted to the Lower Needle Guide of the tool. For example, you can select the large magnetic ring for transporting 10/20 mL vials.
- **Stack** — A passive Tray Holder with a drawer system. It is not temperature controllable.
- **Temperature Controlled Drawer** — An active Tray Holder with drawer system. It is temperature controllable.
- **Liquid Cooled Tray Holder** — A passive module controlled through external liquid circulation bath.

Naming Conventions

This section provides the standard naming convention for the Trays and Tray Types of the TriPlus 100 Liquid Sampler system. Following these conventions will allow the instrument to be pre-configured for certain applications, will simplify software backups and application development, and will improve technical support and training.

An example of naming convention is detailed in [Table 1](#).

Table 1. Example of Tray Types Naming Convention

| Tray Type | Tray Description |
|----------------|--|
| Tray 15 (VT15) | Tray with same footprint as Well Plate; 15 positions (3 x 5). <i>Pattern:</i> Regular for 10 and 20 mL vials with OD 23 mm and height 47/78 mm. |
| Tray 54 (VT54) | Tray with same footprint as Well Plate; 54 positions (6 x 9). <i>Pattern:</i> Regular for 2 mL vials with OD 12 mm and height 34 mm. |
| Tray 70 (VT70) | Tray with same footprint as Well Plate; 70 positions (7 x 10). <i>Pattern:</i> Regular for 1 mL vials with OD 7.5 mm and height 45 mm. Viewing window in position 68 for needle penetration check. |
| Tray 32 (R32) | Tray with footprint for Liquid Cooled Tray Holder; 32 positions (4 x 8). <i>Pattern:</i> Regular for 20 mL vials with OD 23 and height 78 mm. |
| DWP96 | Well Plate Type. Deep Well Plate DW96. 96 positions (8 x 12). <i>Pattern:</i> Regular. <i>Plate Height:</i> 43.0 mm; Well Cavity Depth: 39.0 mm; Well Cavity Diameter: 7.0 mm. |
| MTP96 | Well Plate Type. Microtiter Plate MT96. 96 positions (8 x 12). <i>Pattern:</i> Regular. <i>Plate Height:</i> 14.6 mm; Well Cavity Depth: 10.9 mm; Well Cavity Diameter: 7.0 mm. |
| MTP384 | Well Plate Type. Microtiter Plate MT384. 384 positions (24 x 16). <i>Pattern:</i> Regular. <i>Plate Height:</i> 14.4 mm; Well Cavity Depth: 11.5 mm; Well Cavity Diameter: 3.7 mm. |

Start Screen Icons

The Start screen icons are listed in [Table 2](#).

Table 2. Start Screen Icons (Sheet 1 of 2)





















| Icon | Description |
|---|--|
| Tool and Tool Change Station | |
|  | Syringe Adapter for liquid injections |
| Active Module | |
|  | Agitator |
|  | Vortexer |
|  | Barcode Reader |
|  | Temperature Controller Drawer |
|  | Fast Wash Module |
| Passive Module | |
|  | Tray Holder (rectangular) |
|  | Liquid Cooled Tray Holder |
|  | Standard Wash Station (5 X 10 mL Vials) |
|  | Large Wash Station (2 X 100 mL bottles and 1 Waste Position) |
|  | Solvent Station (Solvent reservoir station for 3 X 100 mL bottles) |
|  | Tray, rectangular (Tray to hold vials with volume from 1 to 40 mL) |
|  | Vials, set of vials |
|  | Vial, single vial (Vial Type CV) |

Table 2. Start Screen Icons (Sheet 2 of 2)

| Icon | Description |
|---|--|
|  | Solvent Reservoir Bottle (Vial Type SR) |
|  | Injector (GC Injector) |
| Synchronization and Signals | |
| I/O | Input and Output Signals |
|  | Input Signal |
|  | Output Signal |
|  | Chromatographic System. Specifies synchronization of Input and Output Signals, Cryo Trap, and Delay Time for a Fake Injection for an analytical system. |
| General Icons | |
|  | TriPlus 100 Liquid Sampler system |
|  | Head (Injection unit) |

The TriPlus 100 Liquid Sampler System

The TriPlus 100 Liquid Sampler system is an integrated sampling system based on three axes: X, Y, and Z, constituted by a basic body on which a series of components are installed.

See [Figure 1](#).

Figure 1. TriPlus 100 Liquid Sampler System Schematic View

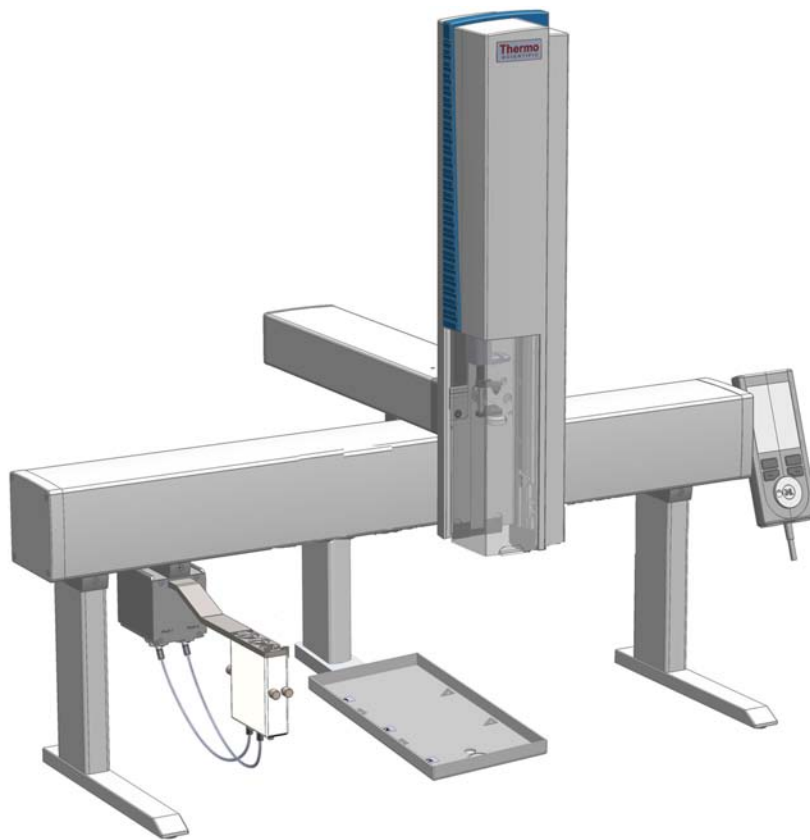

The TriPlus 100 Liquid Sampler system can be installed on the gas chromatographs for sample introduction into up to four injectors.

S/SL, PTV, PKD, and PPKD are the injectors into which the sample may be introduced.

The components of the system are chosen by the operator according to their own analytical demand.

Sampling Unit

The sampling unit consists of the following major components:

- **Sampler Support** — Constitutes the supporting base allowing the installation of the sampler on the gas chromatograph.
- **Crossrails (X and Y-axes)** — The sampler is provided with two sliding crossrails that constitute the basic body:

- **Longitudinal Crossrail (X-axis)**
Represents the X-axis of the system, and the structure bearing the sampling unit components.
- **Orthogonal Crossrail (Y-axis)**
Represents the Y-axis of the system. It slides on the longitudinal crossrail driving the movements of the Head fixed thereto.
- **Head (Z-axis)** — Couples and uncouples the Syringe Adapter for the liquid applications, and accomplishes the necessary movements to carry out the three main operating steps. The Head includes an integrated gas supply.

Modules

This version features the following modules:

- **Washing Station** — Accommodate the vials of solvents and a waste vial or a drain tube to collect the solvents in a waste container.

Three types of washing stations are available:

- Standard Wash Station (5 X10 mL vial)
- Large Volume Wash Station (2 X100 mL reservoir)
- Large Solvents Station (3 X100 mL reservoir)
- **Sample Tray** — It is placed on the dedicated tray holder hanging to the crossrail X. The following options are available according to the type of tray holder in use:
 - 15, 32, 54, 60, and 70 positions.
 - 96 positions Deep Well Plate DW96
 - 96 positions Microtiter Plate MT96
 - 384 positions Microtiter Plate MT384

- **Tray Holder** — Accommodates the sample tray.

Three types of tray holders are available:

- Standard (room temperature) tray holder
- Liquid Cooled Tray Holder
- Temperature Controlled Drawer (it requires a dedicated power supply).

Each type of tray holder accommodates the relevant type of sample tray.

- **Sample Vial**
 - 0.5, 0.7, 2.0, 2.5, 10, and 20 mL
 - 96/384 positions Microtiter or Deep Well plate
- **Syringe Types** — 1.0 µL, 5.0 µL, 10 µL (standard), 25 µL, and 100 µL.

- **Syringe Needle Length** — 57 mm (standard)
- **Agitator** (Incubation Oven) — Accurate thermostating of up to six sample vials is crucial to obtain reproducible results in head-space analysis. This condition is ensured by accurate temperature control of the vials located in the incubation oven.
- **Vortexer** — Used for intensive shaking (orbital interval shaking) at ambient temperature.

Optional Modules

- **Bar Code Reader** — Reads the bar codes located on the vials and sends the content during the report printout.
- **Handheld Controller** — Optional module for setting up and configure the instrument.

Power Module

The sampler is electrically supplied by the dedicated external power module. The TriPlus 100 Liquid Sampler system cannot work without this power module. A second power module is required to supply the Temperature Controlled Drawer.

User Interface

The functions of the TriPlus 100 Liquid Sampler system can be controlled through a data processing system for PC with dedicated software.

The TriPlus 100 Liquid Sampler system can be set up and configured using either the optional **Handheld Controller** or the **Virtual Handheld Controller** (PC software).

Crossrails

The Crossrails constitutes the primary structure up on which the sampling unit components are installed according to the configuration of the sampler.

The two sliding crossrails, shown in [Figure 2](#), constitute the X and Y axes of the sampler. They are connected to one another through a mechanism that manages the movements of the system by both a motorized truck and a tray located in every Crossrail.

Figure 2. Crossrails X and Y

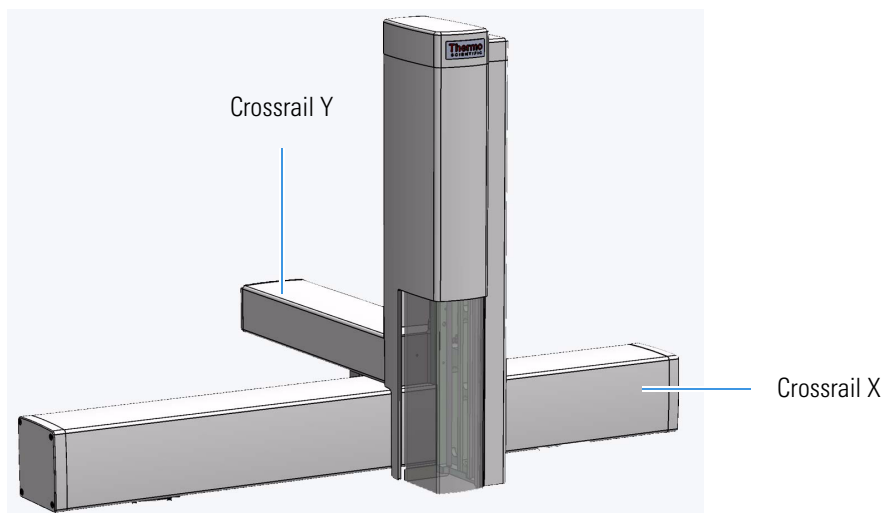

Crossrail X

It represents the X-axis of the system and is the structure bearing the sampling units components. It consists of the following sections:

- **Front-upper section** — The part of the crossrail on which the crossrail Y slides.
- **Lower section** — Includes the slots to connect the sampler support and the components.
- **Back section** — Includes the Control Interface for the connection of the sampling unit to the power module, the GC, and the components installed. Please refer to “[Control Interface](#)” on [page 14](#). It includes the inlet port for the connection of the syringe flushing gas.
- **Internal section** — Contains the main low voltage electronics boards. It also manages the movement along the crossrail X.

Crossrail Y

It represents the Y-axis of the system. It is connected to the crossrail X through the motorized truck. Crossrail Y motors carry out the movements of the Head (Z-axis).

It consists of the following sections.

- **Front section** — Includes the guides and the electric connections for the Head installation.
- **Lower section** — The part that slides along the crossrail X.

Head

It represents the Z-axis of the system. It consists of a vertical structure fixed on the crossrail Y which guides the movements along the X and Y axes. See [Figure 3](#).

Figure 3. Head

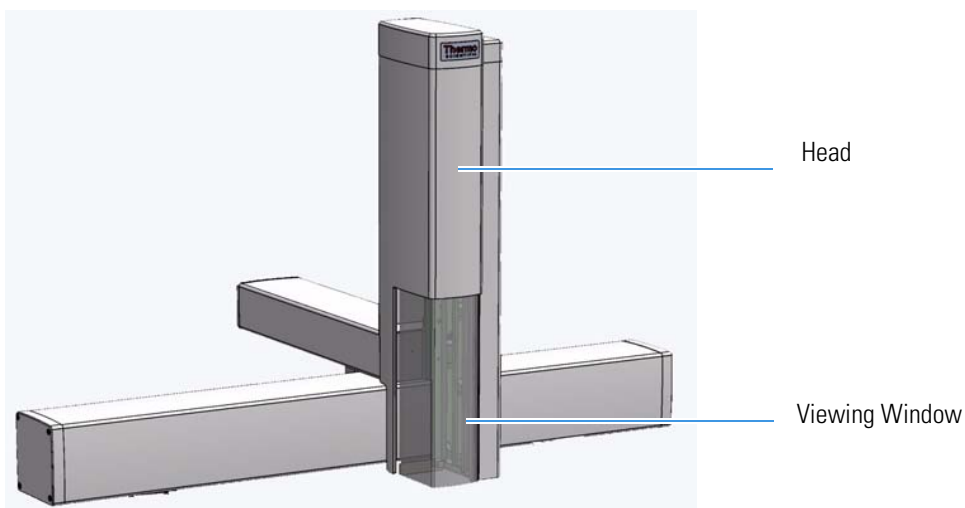

The front side is provided with a viewing window allowing access to the injection device. See [Figure 4](#).

Figure 4. Injection Device

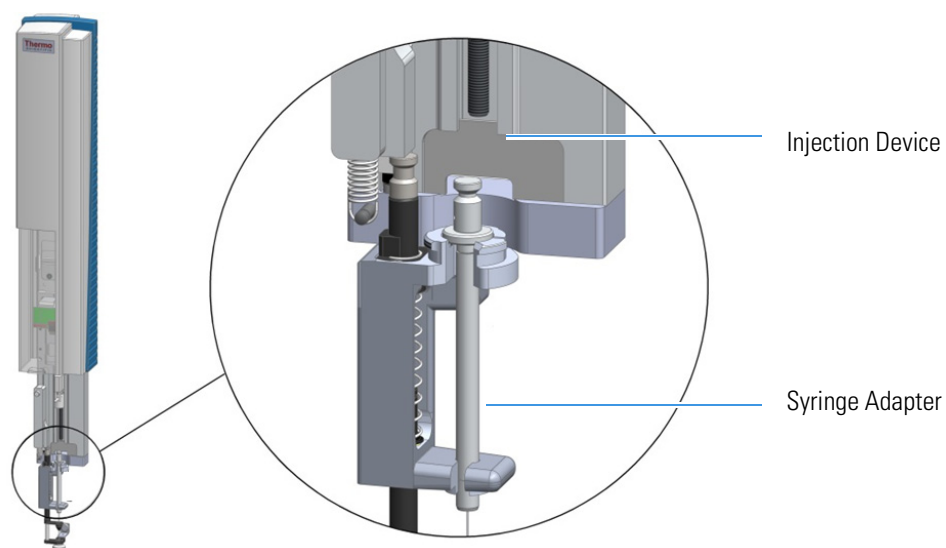

The injection device includes an active needle guide and a coupling plate to couple/uncouple the Syringe Adapter. See [“Syringe Adapter”](#) on [page 13](#).

The movements of the injection device are controlled by stepper motors housed in the Head.

Syringe Adapter

It is used for liquid injection with a metallic plunger typically used for GC technique or with a polymer plunger used for syringes with a larger volume than 10 µL. The syringe is in the holder, and the entire assembly is called Syringe Adapter. The syringe consists of the holder to insert and keep the syringe in position.

The Syringe Adapter is branded by the factory for the basic configuration, which means:

- Tool internal diameter to accept Syringe Glass Barrel with defined outer diameter, for example: 6.6 or 7.7 mm.
- Length of Needle or distance for Needle Guide.

Any syringe with the same characteristics can be inserted in the tool with the described preconditions. Labels for the various syringe types are provided. See the example in [Table 3](#).

Table 3. Some Examples of Labels Description

| Label | Description |
|----------------|--|
| LS 10 µL; NL57 | Syringe Volume: 10 µL; 57 mm Needle Length |

Syringes

The Syringe Adapter is fully compatibility with Thermo Injector technology. See [Table 4](#).

Table 4. LS Tool - Injector Compatibility

| Injector |
|---|
| <p>SSL injector hot needle</p> <ul style="list-style-type: none"> • Split injection — 57 mm needle length • Large Volume splitless — 57 mm needle length |
| <p>SSL injector cold needle</p> <ul style="list-style-type: none"> • SSL injector cold needle — 57 mm needle length |
| <p>PTV injector</p> <ul style="list-style-type: none"> • Conventional injection — 57 mm needle length • Large volume injection — 57 mm needle length |
| <p>PKD injector</p> <ul style="list-style-type: none"> • PKD injector — 57 mm needle length |

Control Interface

The back part of the crossrail X includes the following components as shown in [Figure 5](#).

Figure 5. Control Interface

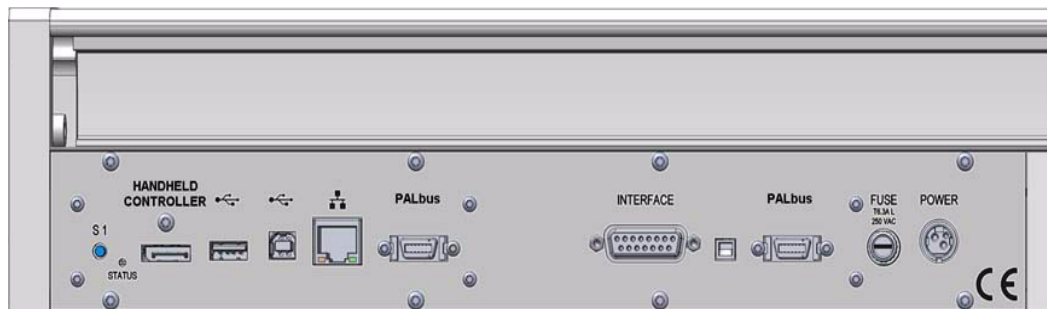

Status — This LED (*Light Emission Diode*) provides indications on the instrument operating conditions showing a solid or blinking light.

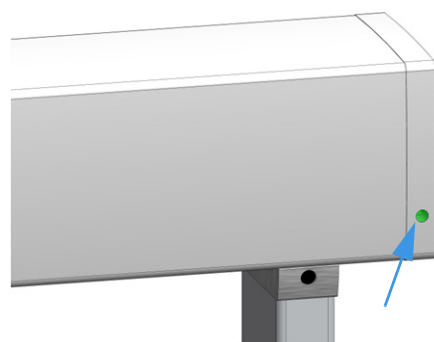

The LED light on the right side cover of the X-axis shows the identical status as the Status Light displayed on the Handheld Controller. See [Table 5](#).

See also the section “[Menu Screen Status Bar Symbols](#)” on [page 39](#), and the section **System Status LED at Status Bar or at X-Axis Side Cover** in the chapter **Troubleshooting** of the *TriPlus 100 Liquid Sampler Hardware Manual*.

Table 5. Status LED Lights (Sheet 1 of 2)



| Symbols | Description |
|---|---|
|  | <p>Green status light, blinking: TriPlus 100 Liquid Sampler system is working (moving). Execution mode. The Handheld Controller is partially blocked to specific actions.</p> <p>Green status light, steady on: TriPlus 100 Liquid Sampler system is ready in Standby. Idle Mode.</p> |
|  | <p>Yellow status light, blinking: The Firmware is booting.</p> <p>Yellow status light, steady on: A problem has been detected which cannot be resolved by the robotic system.</p> <p><i>Examples:</i> Bent needle (mechanical problem), and so on, detected at the moment of sample execution. A software run-time error can also cause a status light change to steady-on yellow.</p> |

Table 5. Status LED Lights (Sheet 2 of 2)

| Symbols | Description |
|---|--|
|  | <p>Blue status light, blinking: The TriPlus 100 Liquid Sampler system is in the process of software Update or Backup. (For the processes Copy Backup and Restore the Status light remains green.)</p> <p>Blue status light, permanent: TriPlus 100 Liquid Sampler system is in a safe state (power reduced to a minimum) and requires manually moving the Head to the Teach Point.</p> <p>Note: If an error is detected at the same time that an action is required according to the Blue Status Light, then by default the yellow status light will dominate.</p> |



- **S1** — Reset button to restore the factory default settings without knowing the IP Address.
- **HANDHELD CONTROLLER** — 20-pin port connector for the connection between the TriPlus 100 Liquid Sampler system and the Handheld Controller.
- **USB Host**  — USB Type A connector for the connection of the USB stick only for service purposes.
- **USB Device/Client**  — USB Type connector for the connection to an USB device or USB client.
- **Ethernet**  — RJ45 Ethernet cable connects the TriPlus 100 Liquid Sampler system directly to a computer, and a LAN (Local Area Network) for the network connection of the TriPlus LAN sampler.
- **BUS** — Two Mini Delta Ribbon 14-pin connectors for the connection to the CPU board and the components installed on the sampler.
- **INTERFACE** — DSB 15-pin female connector for the connection between the sampler and the GC.
- **FUSE** — Housing for the fuse T6.3; 250 VDC. See [Table 6](#).

Table 6. Fuses Parameters

| Parameter | Value |
|-----------------|-----------|
| Rated Current | 6.3 A |
| Rated Voltage | 250 VAC |
| Fuse Dimensions | 5 x 20 mm |

- **POWER** — KYon KPJX-3S-S connector receives 36 V from the Power Module.

Definitions of Active and Passive Hardware Modules

This section describes the hardware modules in more details.

Active Versus Passive Module

An **Active module** is defined as a module that sends or receives specific commands and checks. The control communication is done via the **BUS** serial protocol for all active devices.

A typical example is the motor for the X-Axis that has to be accelerated to a certain speed and stopped after a defined travel distance. The motor records the position at every point of its trajectory and is reported back to the processor via the BUS using the X-motor (Servo motor X-axis).

A **Passive** module is a static device. Typical examples are non-temperature programmable Tray Holders, or a GC Standard Wash Station.

You can easily distinguish the difference between **active** and **passive** devices by checking for any serial connectors at the device. Every active module has two connectors for daisy chaining to the next module. See [Figure 6](#).

Figure 6. Example of Passive and Active Modules

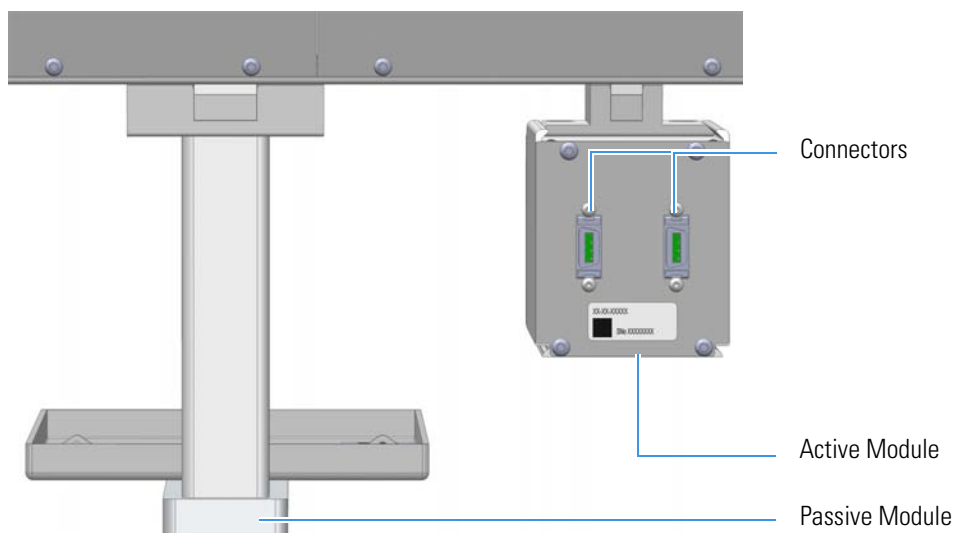

At the level of the Firmware, it is important to understand other differences between the two classes of modules:

- **Active module** — The device firmware is always included in (or is part of) the basic Firmware. When the module is connected to the BUS connector, the device is recognized and made available for use via serial control. A module ID# is automatically provided and stored. Loading or activating a specific firmware object is not necessary. An active device can be de-activated but not deleted. A deactivation is done by disconnecting the serial cable. The device ID# is stored and if the device is re-activated, the same device ID# will be re-assigned.

Note It is possible to delete an active device in the **Service** access level.

- **Passive module** — The template of a passive module is included in (or part of) the basic Firmware.

Using the Handheld Controller, add the module by selecting **Options | Setup | Modules**. A dialog guides you through the screens to define the various Attributes and Parameters. After the newly-defined module is stored, it is available for further setup definitions such as teaching the positions.

A module ID# is automatically provided and stored as long as the device is in operation. Loading or activating a specific device firmware is not possible for a passive module.

A passive module cannot be deactivated but it can be deleted. The module ID# will not be stored. If the same device is re-activated later, another module ID# will be randomly provided.

Note How to physically install, connect and activate an **active** or a **passive** module is explained in the next chapters.

Active Versus Composite Module

The term **Active module** is used for a module which communicates with the BUS. An active module can consist of one or more devices which also communicate with the **Active** versus **Composite module**.

The term **Active module** is used for a module which communicates with BUS. An Active module can consist of one or more devices which also communicate with the BUS but in slave functionality. A typical example is the **Head** (Z-axis) of the TriPlus 100 Liquid Sampler system which contains three different motors, each of them connected to the BUS.

A **Composite module**, such as the TriPlus 100 Liquid Sampler system, is composed of several devices.



Note This differentiation is unimportant for the routine use of the TriPlus 100 Liquid Sampler system. You must understand this difference when a device must be replaced, for example a motor-Z as part of the Head.

Modules Description and Specifications

This section covers the description and specifications of the following modules:

- “Standard Wash Station” on page 19
- “Large Volume Wash Station” on page 20
- “Large Solvent Station” on page 20
- “Fast Wash Station” on page 21
- “Agitator” on page 22
- “Vortexer” on page 24
- “Barcode Reader ” on page 26
- “Standard Tray Holder” on page 31
- “Liquid Cooled Tray Holder” on page 32
- “Temperature Controlled Drawer” on page 33

Standard Wash Station

The Standard Wash Station is shown in [Figure 7](#).

Figure 7. Standard Wash Station with Drainage Adapter

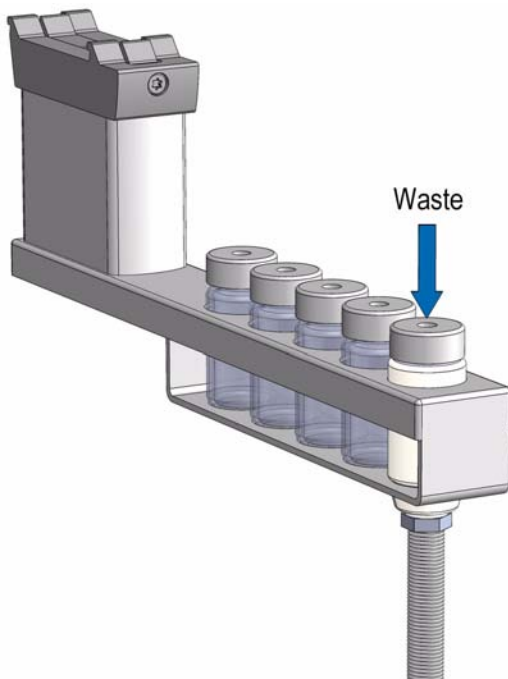

The Standard Wash Station is a passive module containing five 10 mL vials. The configuration within the Standard Wash Station can be flexible. Options include:

- 2 X Wash Vials and 2 X Waste Vials and a Vial dedicated for Internal Standard, Reagent, and so on.
- 4 X Wash Vials and 1 X Waste Vial. This configuration allows using four different Wash Solvents for critical applications

Note The single Waste Vial can be too small in size to accept 4 X 10 mL wash solvent (at worst case).

- When the size of the Waste Vial becomes a problem replace the Vial in the waste position with a drainage adapter.

Large Volume Wash Station

The Large Volume Wash Station is shown in [Figure 8](#).

Figure 8. Large Volume Wash Station

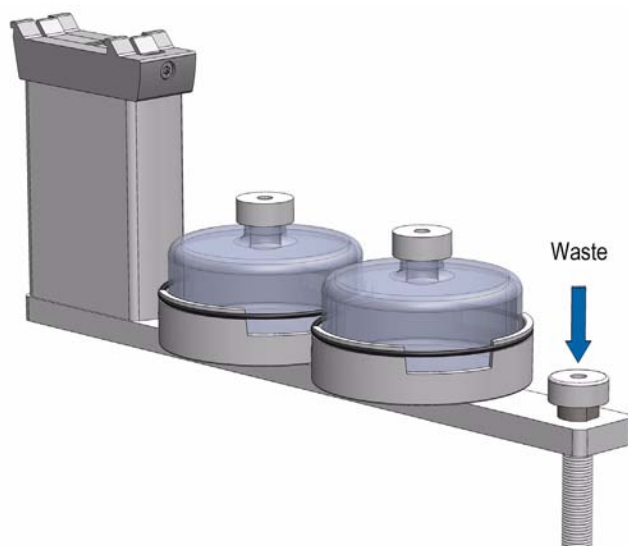

The Large Volume Wash Station is a passive module containing two 100 mL vials and one vial for waste port for diverting waste to large reservoir.

Large Solvent Station

The Large Solvent Station is shown in [Figure 9](#).

Figure 9. Solvents Station

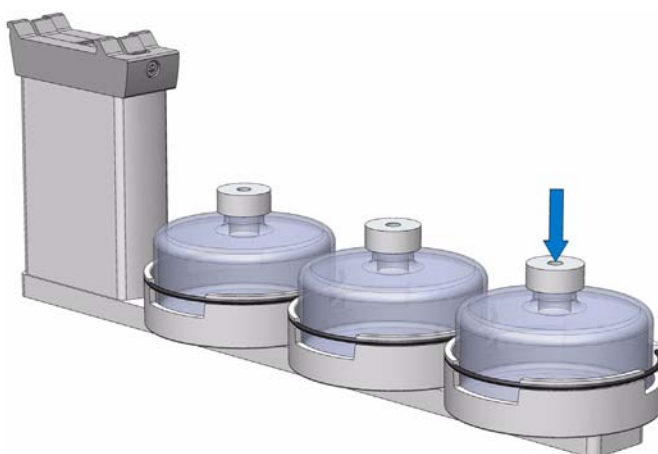

The Large Solvent Station is a passive module containing three 100 mL vials.

Fast Wash Station

The Fast Wash Station is shown in [Figure 10](#).

Figure 10. Fast Wash Station



The Fast Wash Station is an active module. Communication and control of the station is provided through the BUS from the system. Two Micro Pumps actively deliver the required flow of two different wash solvents. The syringe is washed by inserting the needle into a glass liner; the provided wash solution is aspirated and dispensed. The needle is washed outside during this process. The dispensed solvent passes from the overfilled liner into an internal flow channel to the waste outlet. This wash process can be repeated.

The wash solvent can also be changed by moving the syringe to the second wash port and starting the wash process over again. The advantage of this station is that the head does not need to move to the waste position to eject the wash solvent.

The Fast Wash Station dimensions, mass, operating, and environmental requirements are detailed in [Table 7](#) and [Table 8](#).

Table 7. Fast Wash Station - Dimensions and Mass

| Length | Dimension in mm (in.) |
|--------------------------------|---|
| Width | 60 (2.36) |
| Depth | 315 (16.73) Including cable connectors [380 (15.0)] |
| Height | 135 (5.3) Including cable connectors [185 (7.3)] |
| Associated Cables (two pieces) | 0.15 (0.33) |
| Solvent reservoir kit | 1.30 (2.87) Including two 1000 mL bottles |
| Mass | Dimension in kg (lbs) |
| Fast Wash Station | 0.750 (1.65) |

Table 8. Operating and Environmental Requirements

| Parameter | Requirements |
|-----------------------------|---|
| Operating temperature range | 4 to 40 °C |
| Maximum relative humidity | 80%, non-condensing |
| Bench space | Consider bench space for the two 1000 mL bottles, or by your request. |
| Altitude limitations | 3000 m above sea level |

Agitator

The Agitator is shown in [Figure 11](#).

Figure 11. Agitator Module

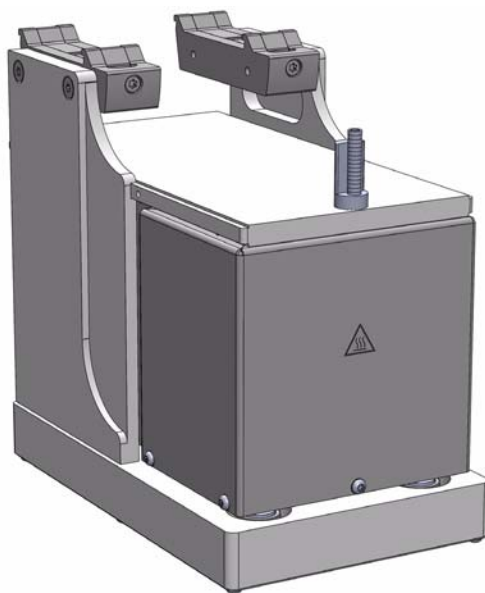

The Agitator is an active module used for heating and shaking the sample. Temperature and shaking parameters can be individually controlled.



WARNING The Agitator can be operated at a maximum temperature of 200 °C.

If operated at this temperature, its outer surface will reach approximately 70 °C. When the Agitator is heated, do not touch the outside surface, do not reach into it; do not try to remove vials manually from it. The vials will be at the selected operating temperature, and there is a danger of burns.



WARNING When sample vials have to undergo heating and agitation, it is important to consider the glass quality. Use high quality glass only. Remember that depending on the application conditions, high pressure can build up in the vial. Whenever a temperature greater than 60 °C is applied, consider the vapor pressure of the solvent used to ensure that no excessive pressure builds up. This is important when using a temperature above 100 °C and especially at the maximum temperature of 200 °C. Be aware that solid materials can also contain volatile compounds such as water (humidity) which could cause build-up of excess vapor pressure. Do not reuse the vials. During the process of washing the vial, micro-cracks can form which will weaken the glass wall and increase the chances of the vial breaking.

The Agitator specifications are:

- **Sample Capacity** — Six heated vial positions for 2 mL, 10 mL, and 20 mL vials.
 - Spacers for 10 mL vials are optionally available.
 - Spacers for 2 mL vials are optionally available.
- **Temperature Control** — From 40 °C to 200 °C in 1 °C increments.
- **Electrical Connectors** — Two BUS connectors for daisy chaining.

The Agitator dimensions, mass, operating and environmental requirements are detailed in [Table 9](#) and [Table 10](#).

Table 9. Agitator - Dimensions and Mass

| Length | Dimension in mm (inches) |
|--|--------------------------|
| Width | 114 (4.45) |
| Depth | 180 (7.09) |
| Height | 176 (6.93) |
| Mass | Dimension in kg (pounds) |
| Agitator (with cable and 6x10 mL vial spacers) | 2.38 (5.25) |

Table 10. Agitator - Operating and Environmental Requirements

| Parameter | Requirements |
|-----------------------------|---------------------|
| Operating temperature range | 40 to 200 °C |
| Maximum relative humidity | 75%, non-condensing |
| Vibration | Negligible |
| Static electricity | Negligible |

Vortexer

The Vortexer is shown in [Figure 12](#).

Figure 12. Vortexer Module

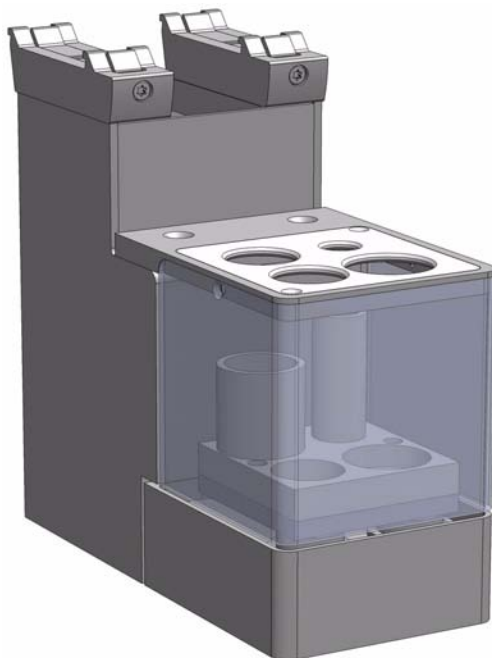

The Vortexer is an active module used for intensive shaking (orbital interval shaking) at ambient temperature. See [Figure 12](#).

Its main application is the automated liquid/liquid extraction of two immiscible solvent phases. An emulsion is temporarily formed which will break after the shaking stops. Only one vial at a time can be treated.

Shaking speed can be selected.

The temperature control of the module is not possible.

WARNING The Vortexer operates at a maximum speed of 2000 rpm. Operating at this speed places very high stress on the glass vials. Use quality glass vials from reliable suppliers only. Do not wash and recycle used vials; there is a danger of micro-cracks present in the glass.



It is mandatory using the mixer with the installed protective cover. During the mixing step it is important to keep the Head always above the vial to avoid an uplift of the vial caused by the spin. Use only one vial at a time for mixing.

The recommended application for the Vortexer is liquid/liquid extraction. If a solid material is mixed with a liquid at high speeds, this will likely cause cracking of the vial. When sample vials have to undergo vigorous agitation, it is important to consider the glass quality. Use high quality glass only.

The Vortexer specifications are:

- **Sample Vial Dimensions** — 2, 10, and 20 mL.
 - 2 mL Vial; diameter 11.5 ± 0.5 mm; height 34 mm (including magnetic cap)
 - 10 mL Vial; diameter 23 ± 0.5 mm, height 48 mm (including magnetic cap)
 - 20 mL Vial; diameter 23 ± 0.5 mm, height 78 mm (including magnetic cap)
- **Sample Capacity** — 1 vial treated at once
- **Electrical Connectors** — Two BUS connectors for daisy chaining
- **Agitation Speed** — Up to 2000 rpm

The Vortexer dimensions, mass, operating, and environmental requirements are detailed in [Table 11](#) and [Table 12](#).

Table 11. Vortexer - Dimensions and Mass

| Length | Dimension in mm (in.) |
|-----------------------|-----------------------|
| Width | 82 (3.23) |
| Depth | 180 (7.09) |
| Height | 177 (7.0) |
| Mass | Dimension in kg (lbs) |
| Vortexer (with cable) | 2.10 (4.63) |

Table 12. Operating and Environmental Requirements

| Parameter | Requirements |
|-----------------------------|---------------------|
| Operating temperature range | Ambient, no control |
| Maximum relative humidity | 75%, non-condensing |
| Vibration | To be tested |
| Static electricity | Negligible |

Barcode Reader

The Barcode Reader is shown in [Figure 13](#).

Figure 13. Barcode Reader



The Barcode Reader is an active module used to decode and read barcodes applied in horizontal bars on vials of 1 to 20 mL volume.

The Barcode Reader consists of two scanners. The vial with the barcode label is positioned in the middle. The distance between the two scanners is optimized by the scan angle. The two scanners are activated one after another.

- If the first scanner can read and decode the barcode symbols, the second scanner is not activated.
- If the first one fails, the second scanner is activated, and if the barcode is positively interpreted the process is ended.

When both scanners cannot read the barcode, an error exception is run. The error handling itself is part of the CDS software and in most cases you can select one of the following options:

- Continue with sample handling but stamp the field **Sample ID** with an error comment **BC not readable**.
- Stop the process of data handling, stop the entire **Sample List**.

This approach of using two scanners confers the advantage that the vial with the barcode label is not required to be oriented directly towards the scanner. Respecting the minimum length of 19 mm for the barcode allows the vial be positioned randomly in the and the barcode label will be successfully interpreted.

Safety Information

The installed Laser device is a Class 1 Laser Product.



WARNING Class 1 Laser devices are not considered to be hazardous when used for their intended purpose. The following statement is required to comply with international regulations:

Use of controls, adjustments or performance of procedures other than those specified herein might result in hazardous laser light exposures.

Figure 14 shows the laser warning label and the location of the laser aperture.

Figure 14. Laser Warning Label and Laser Aperture

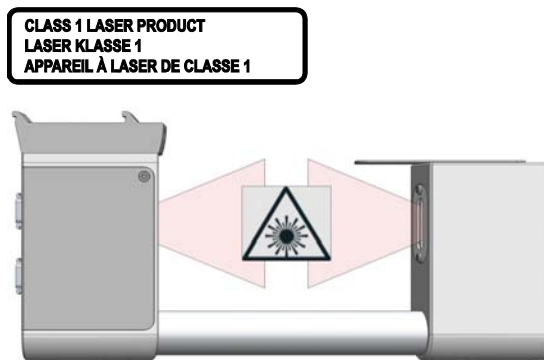

The selected Laser Class 1 for the module Barcode Reader complies with the following regulations:

- 21 CFR1040.10 and 1040.11 except for deviations pursuant to Laser Notice No. 50, dated July 26, 2001.
- EN60825-1:1994 + A1:2002 + A2:2001
- IEC60825-1:1993 + A1:1997 + A2:2001

The software contains a built-in safety time limit such that the laser scanning mechanism cannot be operated in AIM mode for more than 5 continuous seconds.

Supported Types of Barcode Symbols

The following barcode types can be decoded. See [Table 13](#).









Prerequisites are:

- Horizontal scan line
- 1D scanner

1 Getting Familiar with Your TriPlus 100 Liquid Sampler

Barcode Reader

Table 13. Barcode Symbology

| Barcode Type | Description | Min Length | Max Length | Barcode Symbology |
|------------------------------------|--|------------|------------|---|
| Key for Barcode Symbologies | | | |  |
| UPC-A | Universal Product Code, 12 numerical digits. 11 usable digits + 1 check digit. | 12 | 12 | <p>UPC Version A</p>  |
| UPC-E | Universal Product Code, Zero-compressed UPC code, 7 numerical digits. 6 usable digits + 1 check digit. | 6 | 6 | <p>UPC Version E</p>  |
| EAN-8 | Derived from the longer European Article Number (EAN-13), 8 numerical digits. 7 usable digits + 1 check digit. | 7 | 7 | <p>EAN8</p>  |
| EAN-13 | European (International) Article Number, 13 numerical digits. 12 usable digits + 1 check digit. | 12 | 12 | <p>EAN13</p>  |
| Code-128 | High density barcode for alphanumerical codes, supporting all 128 ASCII characters. | 1 | Unlimited | <p>Code 128</p>  |
| EAN-128/GS10128 | Alpha-numerical codes, supporting all 128 ASCII characters. | 1 | 48 | <p>EAN128 / GS1-128</p>  |
| Code 39 (3 of 9) | Alphanumeric code, consisting of uppercase letters (A-Z), numeric digits (0-9) and some special characters (-, ., \$, /, +, %, and space). | 1 | Unlimited | <p>3 of 9 (Code 39)</p>  |
| 2 of 5 Interleaved | Numerical characters. | 1 | Unlimited | <p>2 of 5 Interleaved</p>  |
| ISBT 128 | Used for labeling of human blood. | 1 | Unlimited | Application specific barcodes |

Approved Barcode Labels

The barcode labels should be made of polyester and not paper. Polyester can withstand high temperatures (Agitator 200 °C maximum) and the barcode lines will be printed clearly.

The minimum length of the barcode is 18 mm if used with a 20 mL vial.

This dimension refers to the actual barcode length and not the label itself. Adapt the label accordingly.

Please note that this is the minimum length; when possible use larger dimensions for reliable processing of the barcodes.

Barcode Label Positioning

Place the barcode label on the vial such that the barcode bars are horizontally positioned.

- **Maximum tilt of the barcode label:** +/- 20°.
- **Label Width:** The barcode label width (length of the bars/spaces) has to be at least 18 mm.
- **Minimal barcode density (minimal width of a bare or a space):**
5 mil (0.005") / 0.127mm

The allowed area for the placing of the label is given in [Figure 15](#).

Figure 15. Examples of Barcode Label Positioning and Label Size

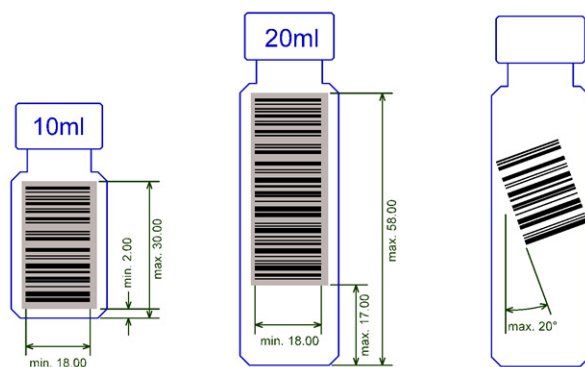

Reading the Barcode from a Vial or Well Plate

The Barcode Reader reads a barcode label from an individual vial, but it is not able to scan and treat multiple units of information, as would typically be received from a multiple well plate.

Multidimensional Barcodes

The scan engine used for the Barcode Reader is designed as a one-dimensional (1D) scanner. Two-dimensional barcodes (2D) cannot be decoded.

Barcode Label Size

The minimum length of the barcode is 19 mm if used with a 20 mL Vial. Please note that this refers to the actual barcode length and not the label itself.

Barcode Reader Specifications

The Barcode Reader Specifications are:

- **Vial Sizes** — 2 mL, 10 mL, and 20 mL
- **Electrical Connectors** — Two BUS connectors for daisy chaining.

The Barcode Reader dimensions, mass, operating and environmental requirements are detailed in [Table 14](#) and [Table 15](#).

Table 14. Barcode Reader - Dimensions and Mass

| Length | Dimension in mm (in.) |
|------------------------------------|------------------------------|
| Width | 30 (1.18) |
| Depth | 273 (10.75) |
| Height | 128 (5.04) |
| Mass | Dimension in kg (lbs) |
| Barcode Reader Module (with cable) | 0.83 (1.83) |

Table 15. Barcode Reader - Operating and Environmental Requirements

| Parameter | Requirements |
|---------------------------|---------------------|
| Maximum relative humidity | 75%, non-condensing |
| Vibration | Negligible |
| Static electricity | Negligible |

Standard Tray Holder

The Standard Tray Holder is shown in [Figure 16](#).

Figure 16. Standard Tray Holder

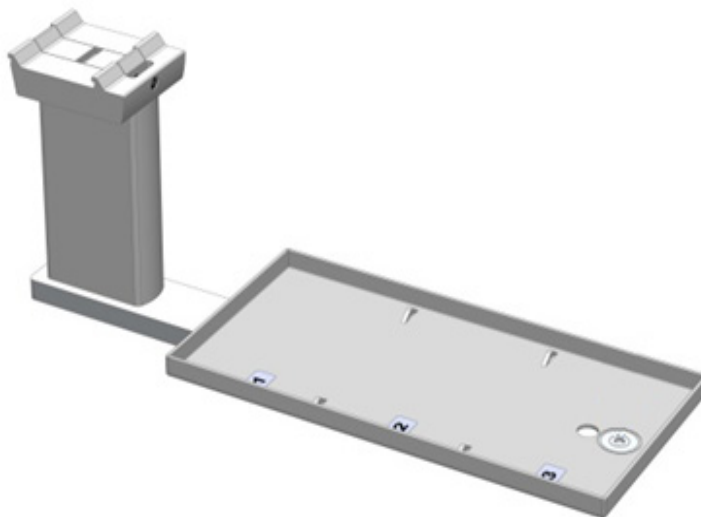

The Standard Tray Holder is a passive module where up to four different trays can be simultaneously installed, each compatible with:

- Three sample tray VT15, VT54, VT70

The Standard Tray Holder specifications are:

- **Sample Capacity** — 648 x 2 mL vial
- **Vial Size** — 0.3, 0.5, 0.7, 2.0, 2.5, 10, and 20 mL and micro volume non-standard vials
- **Electrical Connectors** — None

The Standard Tray Holder dimensions and mass are detailed in [Table 16](#).

Table 16. Standard Tray Holder - Dimensions and Mass

| Length | Dimension in mm (in.) |
|--------------------------------|-----------------------------|
| Width | 134 (5.28) |
| Depth | 375 (14.76) |
| Height | 103 (4.06) |
| Compartment Width/Depth/Height | 110/220/46 (4.33/8.66/1.81) |
| Mass | Dimension in kg (lbs) |
| Standard Tray Holder | 2.50 (5.51) |

Liquid Cooled Tray Holder

The Liquid Cooled Tray Holder is shown in [Figure 17](#).

Figure 17. Liquid Cooled Tray Holder

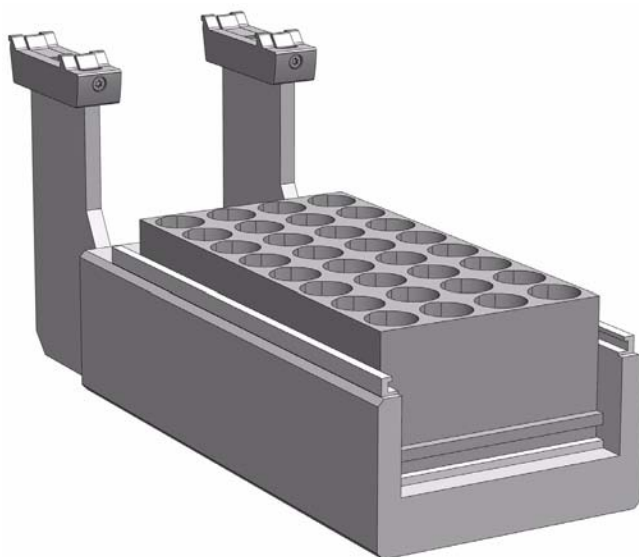

The Liquid Cooled Tray Holder is a passive module for an external re-circulating bath.



CAUTION The Liquid Cooled Tray Holder operates within a temperature range from +4 to 70 °C.

The Liquid Cooled Tray Holder specifications are:

- **Sample Capacity** — Holds one tray for 32 vials capacity of 10 mL and 20 mL vials.
- **Temperature Control** — From 4 °C to 70 °C controlled through external liquid circulation bath, not provided.
- **Connection Tube Dimensions** — Stainless steel tube, OD 8 mm (0.3 inch), ID 6 mm (0.24 inch) open tube, for hose connection).
- **Electrical Connectors** — None

The Liquid Cooled Tray Holder dimensions, mass, operating and environmental requirements are detailed in [Table 17](#) and [Table 18](#).

Table 17. Liquid Cooled Tray Holder - Dimensions and Mass (Sheet 1 of 2)

| Length | Dimension in mm (in.) |
|--------|-----------------------|
| Width | 134 (5.28) |
| Depth | 375 (14.76) |

Table 17. Liquid Cooled Tray Holder - Dimensions and Mass (Sheet 2 of 2)

| Length | Dimension in mm (in.) |
|--------------------------------|-----------------------------|
| Height | 103 (4.06) |
| Compartment Width/Depth/Height | 110/220/46 (4.33/8.66/1.81) |
| Mass | Dimension in kg (lbs) |
| Liquid Cooled Tray Holder | 2.50 (5.51) |

Table 18. Liquid Cooled Tray Holder - Operating and Environmental Requirements

| Parameter | Requirements |
|---------------------------|---------------------|
| Maximum relative humidity | 80%, non-condensing |
| Vibration | Negligible |
| Static electricity | Negligible |

Temperature Controlled Drawer

The Temperature Controlled Drawer is a temperature controlled sample tray that keeps the analytical sample below or above ambient temperature. See [Figure 18](#).

Figure 18. Temperature Controlled Drawer

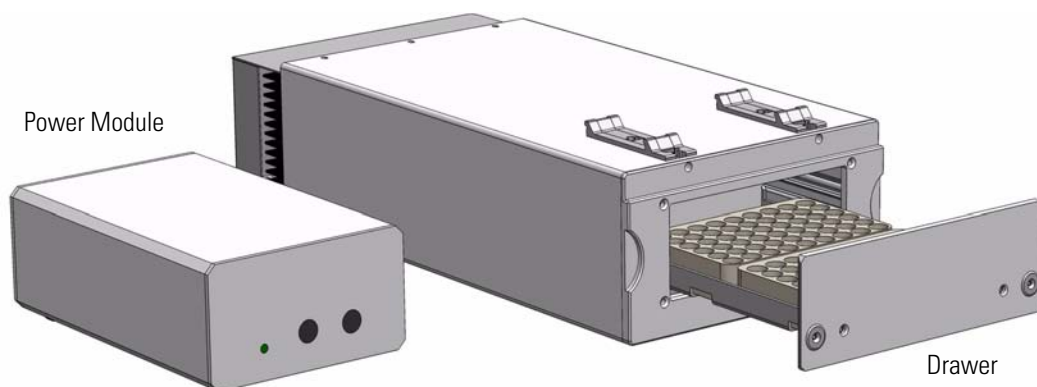

It is an active module with one drawer, two slots, and heated or cooled with a Peltier device. Includes a separated power supply.



WARNING It is mandatory to use a second Power Module. Do not use the same power supply as used for the TriPlus 100 Liquid Sampler system. See the chapter **Installation of the TriPlus 100 Liquid Sampler** in the *TriPlus 100 Liquid Sampler Hardware Manual* for details.

The position of the drawer is recognized by a sensor, and translated from the software in the following descriptions. See [Figure 19](#).

Figure 19. Two Positions of Temperature Controlled Drawer

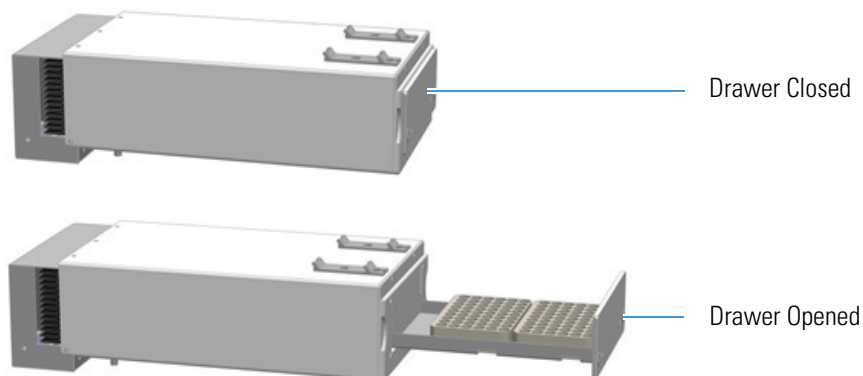

Note An **Opening** drawer status indicates an undefined status, or could also signal a defective PCB or sensor. Check whether the status changes after manually opening and closing the drawer.



CAUTION This module can adapt to Racks made for different vial sizes. When the different racks are used, consider the different vial heights and ensure that the Stack Drawer Magnet, attached to the lower needle guide, does not catch at the front row of vials from behind the rack.

Temperature Control

The cooling/heating capacity of a temperature control device based on the Peltier technique is always relative to room temperature. The maximum temperature difference that can be reached between the device and ambient temperature is limited. The Temperature Controlled Drawer can attain a minimum of 14 °C ($T\Delta$) below ambient temperature.

The controller allows the user to set a range of temperatures from +1 to 45 °C.

The actual temperature range selections are greater than the actual specified limits (+4 to 40 °C). This allows to reach the desired temperature to be reached more easily when the ambient temperature is too high or too low. For example, heating to a higher temperature could be important for metabolism or kinetics studies at the human body temperature of 37 °C.

The cooling option is usually necessary to protect the sample from higher ambient temperatures during the analytical run time. Temperature Controlled Drawer is rarely used to store a sample at a given temperature for prolonged periods.

The displayed temperature represents the temperature in the compartment and not in the sample liquid. To verify the temperature independently, insert a temperature probe at the front of the compartment by removing one plastic screw from the front cover.

Position the probe in the middle of the drawer where the Tray separator projects upwards. Tape the probe to the metal plate of the drawer.

To reach +4 °C in the analytical solution, program a set value lower than +4 °C. The material used to contain the sample may be glass, polypropylene, polyethylene, or similar polymer products. All of these have excellent insulating properties.

If the sample has to be cooled as low as +4 °C, it is advisable to cool the sample Tray first in a refrigerator before the Tray is placed into a Temperature Controlled Drawer. This shortens the cool-down time.

Temperature Alarm

A fuse to prevent overheating is built in for unattended automated runs. The Peltier element will turn off automatically at $+72 \pm 5$ °C.

A damaged over-temperature fuse must be replaced by an authorized Thermo Fisher Scientific service engineer.

Temperature Stability

The following guidelines are recommended:

- Switch on the Temperature Controlled Drawer at least 30 minutes before an analytical operation at +10 °C or 75 minutes before an operation at +4 °C.
- For high-throughput analyses – typical cycle time of 60 seconds or less per analysis – leave the drawers open between injections.
- For longer cycle times, it is recommended to use the **System** option to close the drawer after each sampling.
- Select the drawer-closing method from the **Cycle Activities** menu.

Condensation Build-up

Condensation build-up is directly related to the ambient temperature and humidity (dew point). Long-term tests have shown very little condensation build-up in an environment with relative humidity up to 60% and ambient temperatures of 22 ± 2 °C.

Condensation at the bottom of the compartments will be channeled to the drain outlet labeled **Condensation Drain**. The outlet is plugged with a paper filter. This helps to evaporate the collected water in the drain line using the excess heat from the Peltier element. A drain line from the outlet to a reservoir bottle is not necessary under normal conditions.

Safety Warning

If a purge gas is used, it is your responsibility to ensure that a two-stage safety pressure regulating device is installed between the gas supply and the Temperature Controlled Drawer.

Note Do not use any flammable or explosive gas such as hydrogen.

If the Temperature Controlled Drawer is operated under severe conditions, a flow of clean and dry (oil-free) air or nitrogen could be used to dry the compartments continually.

Connect the corresponding gas line to the Swagelok fitting (1/8") at the back of the **Temperature Controlled Drawer** labeled **Purge Gas**. A flow of approximately 300 to 400 mL/min is required to keep the compartments moisture-free.

If using an application that produces an acidic vapor phase, use the same gas line connection to flush a stream of inert gas, such as nitrogen or helium, into the compartments. A stream of a few mL/min can help to avoid corrosion of the rolls. Checking the lines regularly for condensation build-up is recommended.

It is good practice to clean the inside of the Temperature Controlled Drawer when changing analytical samples. Dry out the Temperature Controlled Drawer at ambient temperature at regular intervals. Open the drawers 1 to 5 cm to allow air circulation. The compartment drying frequency depends greatly on the ambient conditions.

Temperature Controlled Drawer Specifications

The specifications are:

- **Sample Capacity** — Accommodate two different sample trays.
Compatible VT70, VT54 and VT 15 (10 mL vials only).
- **Total vial height** — 47 mm (including cap)
- **Temperature Control** — From 4°C – 40°C in 0.1 °C increments.
Peltier element for the cooling device.
- **Temperature Cooling** — The specification for the Temperature Controlled Drawer temperature cooling is defined as:
 $T\Delta = \geq 14.0\text{ }^{\circ}\text{C}$ within 60 minutes.
 $T\Delta = T\text{ Room temperature} - T\text{ Temperature Controlled Drawer}$
- **Electrical Connectors** — Two BUS connectors for daisy chaining and a connector for external power supply.

The Temperature Controlled Drawer dimensions, mass, operating and environmental requirements are detailed in [Table 19](#) and [Table 20](#).

Table 19. Temperature Controlled Drawer - Dimensions and Mass

| Length | Dimension in mm (in.) |
|--------------------------------------|------------------------------|
| Temperature Controlled Drawer | |
| Width | 197 (7.78) |
| Depth | 425 (16.73) |
| Height | 103 (4.06) |
| Power Supply | |
| Width | 135 (5.31) |
| Depth | 215 (8.46) |
| Height | 75 (2.95) |
| Mass | Dimension in kg (lbs) |
| Temperature Controlled Drawer | 3.57 (7.87) |
| Power Supply | 1.30 (2.87) |
| Associated cables (3 pieces) | 0.50 (1.10) |

Table 20. Temperature Controlled Drawer - Operating and Environmental Requirements

| Parameter | Requirements |
|-----------------------------|---|
| Operating temperature range | 4 to 40 °C |
| Maximum relative humidity | 75%, non-condensing |
| Bench space | At least 50 mm (2 inches) at the back space for air circulation. Access to power switch(es) and power cords. |
| Vibration | Negligible |
| Static electricity | Negligible |
| Altitude limitations | 3000 meters above sea level |

Handheld Controller (Terminal)

This section provides a description of the Handheld Controller.

Menu Screen

Different menu screens are displayed, depending on the TriPlus 100 Liquid Sampler system operating state and the particular function being accessed by the operator. All menu screens have the same basic format. The uppermost line is the **Status bar** where the selected section, the status and time are displayed.

The **Content Area** shows the list of selected items. The **Function Keys** are located in the **Menu Bar**. See [Figure 20](#).

Figure 20. Main Screen

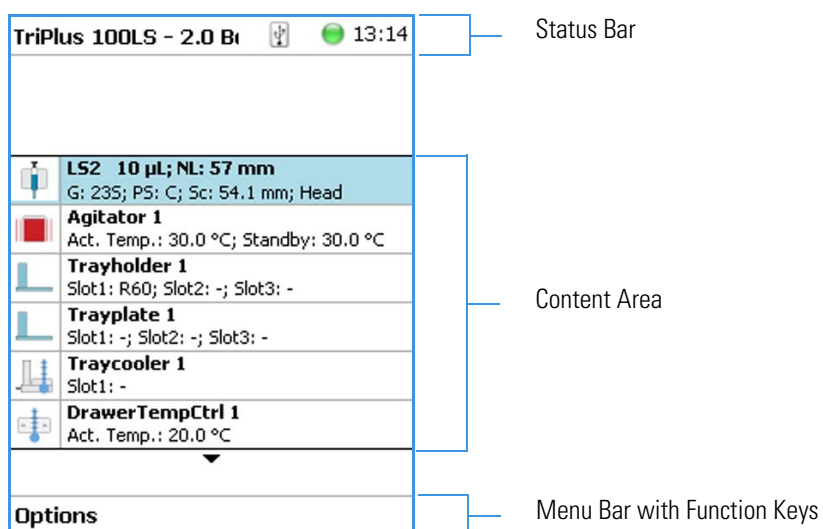







Note Start Screen displays the Active Modules which can be heated, cooled, or both, the Cooled Stack Single, and the Tray Holder(-s) as the only passive module.

Menu Screen Status Bar Symbols

The following symbols can be displayed in the Menu Screen Status Bar.

Table 21. Menu Screen Status Bar Symbols

| Symbols | Description |
|---|--|
|  | <p>Green status light, blinking: TriPlus 100 Liquid Sampler system is working (moving). Execution mode.</p> <p>The Handheld Controller (Terminal) is partially blocked to specific actions.</p> <p>Green status light, steady on: TriPlus 100 Liquid Sampler system is ready in Standby. Idle Mode.</p> |
|  | <p>Yellow status light, blinking: The Firmware is booting.</p> <p>Yellow status light, steady on: A problem has been detected which cannot be resolved by the robotic system.</p> <p><i>Examples:</i> Bent needle (mechanical problem), missing Tool, and so on. detected at the moment of sample execution. A software run-time error can also cause a status light change to steady-on yellow.</p> |
|  | <p>Blue status light, blinking: The TriPlus 100 Liquid Sampler system is in the process of software Update or Backup. (For the processes Copy Backup and Restore the Status light remains green.)</p> <p>Blue status light, permanent: TriPlus 100 Liquid Sampler system is in a safe state (power reduced to a minimum) and requires manually moving the Head to the Teach Point.</p> <p>Note: If an error is detected at the same time that an action is required according to the Blue Status Light, then by default the yellow status light will dominate.</p> |
|  | <p>USB Symbol: A USB device is connected to control.</p> |
|  | <p>Message (Envelope): A system message is pending.</p> <p><i>Example:</i> Error message after software upgrade or after a device has been disconnected. In User Access Level the message symbol is displayed only. To view and process the system message(-s) the operator has to change the access level to Extended User.</p> |
|  | <p>Key is the indicator for the access level Extended User.</p> |
|  | <p>Flat Wrench is the indicator for the access level ServiceUser.</p> |

Function Keys and Buttons

Options for a particular menu are assigned to the corresponding function key on the left side. See [Figure 21](#).

Figure 21. Handheld Controller Buttons

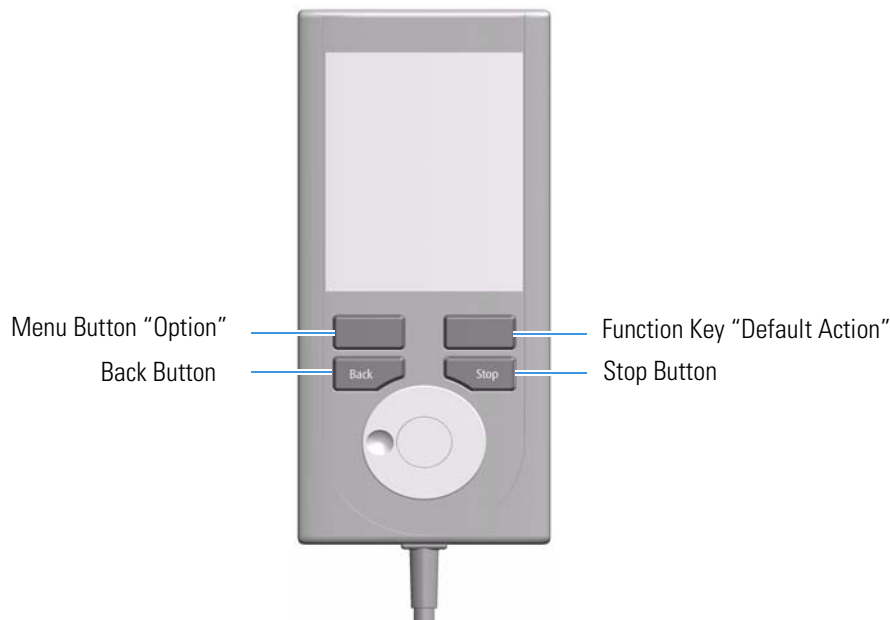

- The Menu Button **Option** on the left side opens a pull-up menu, and is a dynamic allocatable key.
- The Function Key on the right side is reserved for **Default Actions**, such as **Ok**, **Next**, and so on.
- Pressing the **Back** button returns to the previous menu. If the Back button is pressed continuously, the cursor will jump back to the home screen (start page).
- Pressing the **Stop** button stops the ongoing activity at the first possibility. The behavior is closer to stop the run, but the stop itself occurs after an activity has completed its tasks, for example the filling of a syringe.

Note The term **Stop** usually relates to the controlled end of a process, for example finishing a sample from the sample list. The automated run is paused and the user has the possibility to interfere with, make corrections to, continue with or stop the run completely. The **Stop** button used with the TriPlus 100 Liquid Sampler system can terminate the process during the run.

Scroll Wheel and Enter Button

Rotate the outer knob to scroll through items in a menu. To select a highlighted item, press the **Enter** button (central knob). Use the outer knob to scroll through the available options for that item or to change a numeric value. Press the inner knob again to enter the displayed option. The inner knob is also used for other operations that require an Enter function to continue or complete an operation.

Handheld Controller Versus the Virtual Handheld Controller

With every TriPlus 100 Liquid Sampler system, Virtual Handheld Controller Software is provided. As indicated by its name, this software replaces the actual hardware, the Handheld Controller. However, the Handheld Controller is still available as an option.

Figure 22. Handheld Controller and Virtual Handheld Controller



The functionality of both the hardware **Handheld Controller** and the **Virtual Handheld Controller** software are basically the same. Menus, selection of modules, definition of attributes, or feeding parameter values are identical. The only difference is the handling.

When using the Handheld Controller, use the Scroll Wheel, Enter button, Menu Buttons, and so on. If the software Virtual Handheld Controller is running, the keyboard functions are used.

For example: when the position of a module is defined as the X-, Y-, Z-, the values are changed by moving the arrow key up and down.

To open a pull-up menu, use the **Enter** key and the menu items, where for example a name has to be given. You receive the same context menu to enter a number or character. See [Figure 23](#). Use the mouse cursor to select the name. Do not use the standard keyboard keys to select the name.

Figure 23. Example Context Menu to Enter a Password

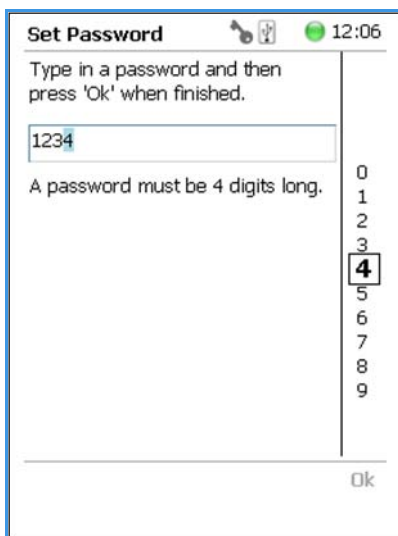

TriPlus 100 Liquid Sampler Basic Information

This chapter provides basic information for starting the TriPlus 100 Liquid Sampler system, and for using the Handheld Controller.

Basic information is provided for the different **Access Levels** for starting the TriPlus 100 Liquid Sampler system and for using the Handheld Controller. The use of the Handheld Controller is similar to the Virtual Handheld Controller, and to the PC software-based Handheld Controller.

Contents

- [Starting the TriPlus 100 Liquid Sampler System](#)
- [Access Levels](#)
- [User Level](#)
- [Extended User Level](#)
- [Service Level](#)
- [Setup, Installation, and Maintenance Menu Item](#)
- [Help Menu Item](#)
- [About Menu Item](#)
- [Shutdown Menu Item](#)
- [Operation of the TriPlus System in Combination with Other Chromatography Data Systems](#)

Starting the TriPlus 100 Liquid Sampler System

This section describes how to start the TriPlus 100 Liquid Sampler system.



CAUTION Before starting the TriPlus 100 Liquid Sampler system, make sure that the sampler and all the modules are properly already installed. A syringe of the appropriate type, should be installed in the Syringe Adapter.

How to Start the TriPlus 100 Liquid Sampler System

1. Turn on the power and observe the software loading process; the start screen appears. See the example of [Figure 24](#).

Figure 24. Example of Start Screen

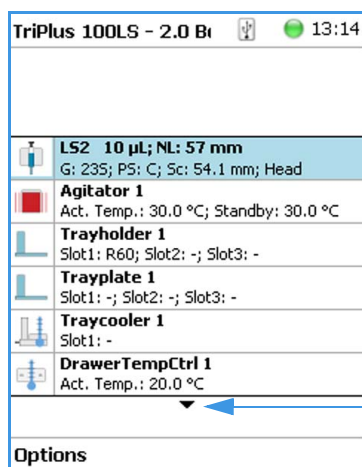

The modules listed on the Start Screen are all active and passive modules which are part of the system configuration. The classes I/O Interfaces and Chromatographic Systems are indicated as well. The only exception is the class Obstacles, which is not displayed on the Start Screen.

The arrow below the list of modules indicates that the user must scroll down to see the remaining part of the list.

In case any error occurs during the start-up process, the start screen shows a blinking **Envelope** in the **Status Line** as an indicator of a Pending Message, a Service Issue, or both. See [Figure 25](#).

Figure 25. Indicating Messages

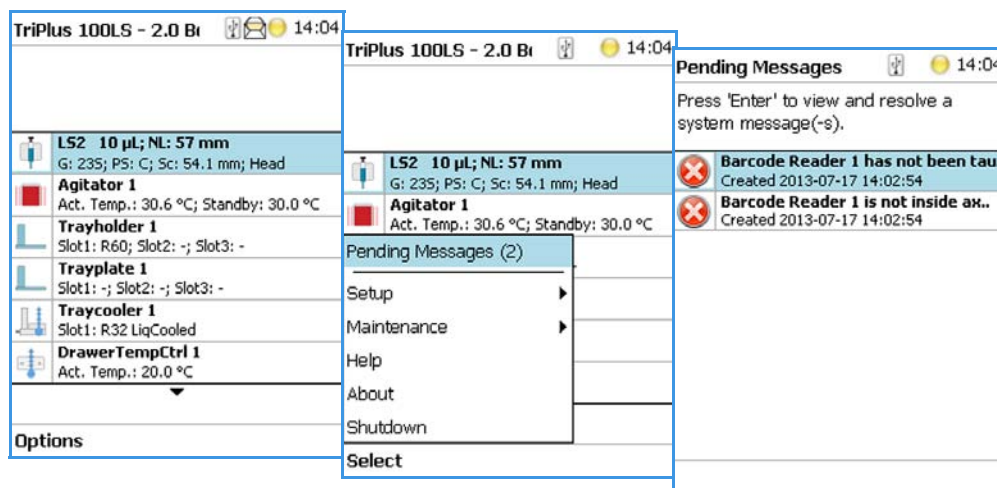

The envelope symbol indicates that a message pending or a **Service Issue** is found. When powered up, the TriPlus 100 Liquid Sampler system is always in the **User access level**.

In this level, the message symbol is visible in the status line, but you have no access rights to verify or acknowledge the error.

Changing the Access Level to **Extended User**, you can see details of the messages by selecting each message line and pressing **Enter**. The Pending Message in the example shows that the reconnected Barcode Reader has not been taught yet.

See the example in [Figure 26](#).

Figure 26. Example of Agitator Missing in Extended User Level

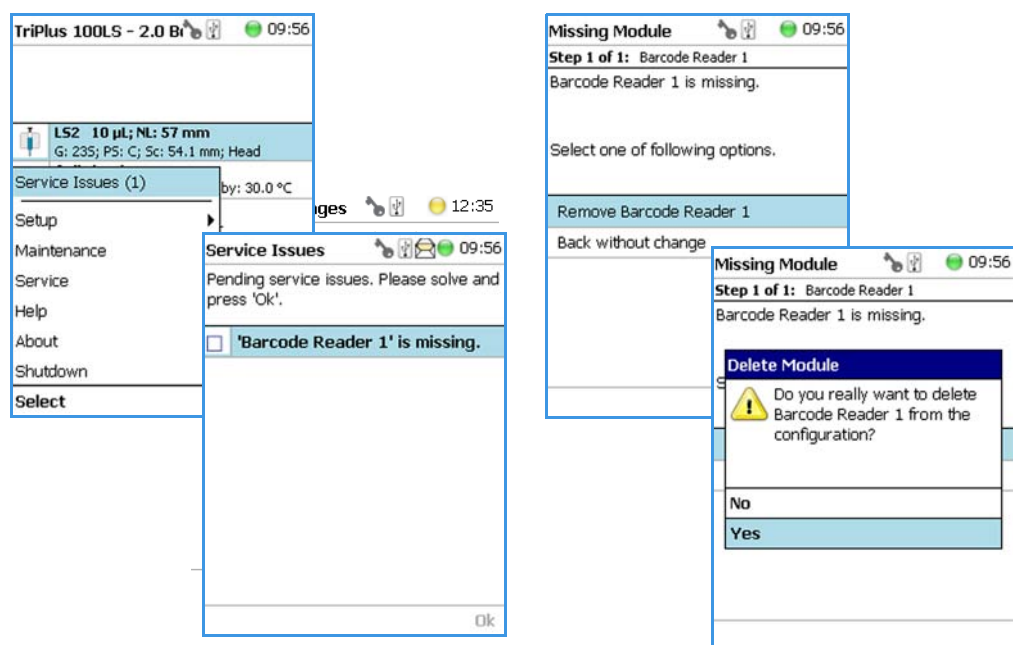

2. To retrieve the message proceed as follows:
 - a. Change the Access Level to Extended User.
 - b. Press the **Options** key to access the pull-up menu for further information.
 - c. Select the menu item Pending Message to receive detailed information on the error message.

A common reason for an error is typically when a **BUS cable** is not connected from one to another active module. During the boot-up procedure, the presence of all active modules is verified. If one or more modules are not found, (or it is not possible to check functions such as **Homing**) an error is recorded.

The messages accompanied by the **Exclamation Mark** warning symbol indicate that a module has not been completely configured. [Figure 27](#) shows an example where the Agitator has not been set.

See also the information provided by the error message or consult the chapter **Troubleshooting** in the *TriPlus 100 Liquid Sampler Hardware Manual*.

The example in [Figure 27](#) shows the resulting errors when the Vial Type of the Agitator cable are not set, and the homing could not be performed. All the subsequent boot-up checks failed.

Figure 27. List Items of Pending Messages

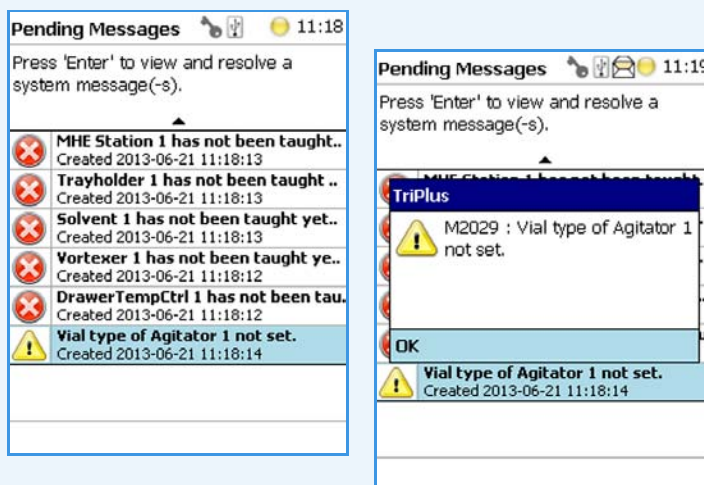

When an error is observed, check all connections, try to eliminate the source of the problem, and restart the TriPlus 100 Liquid Sampler system again.



IMPORTANT When the TriPlus 100 Liquid Sampler system has restarted, it is highly recommended selecting the menu item **Check Configuration** under the class **Maintenance**. Activating this item will check the entire system for any open issues. If all of them are resolved, the green status light will be displayed. If an envelope Message is displayed once more, this indicates an unresolved issue. Continue to resolve the open issue and check the system again under Check Configuration.

Short-cuts from Startup Screen

Note Selecting a menu list item from the startup screen provides direct access, and offers the same functionality as when selecting the item using the path **Menu Button | Options | Setup | Modules**.

The following steps are required to use the short-cuts:

1. Position the cursor on the list item at the start screen for which you wish to check certain parameters.

2. Press the **Enter** button to open the dialog for the selected item.
3. Selecting the **Options** pull-up menu, it provides a list of specific tasks, limited to the typical needs for routine work.

Note Parameters which can be modified are detailed in “[Setup Menu Item](#)” on [page 55](#). Parameters which have read-only access are often self-explanatory and are usually only mentioned in the listing.

Access Levels

The Firmware is designed with three different **Access Levels**. Each level accesses its own discrete items and sections of the firmware. The purpose of this distinction is to display only specific items and sections of the firmware for each level. Settings which must be changed rarely, such as those set during installation of the TriPlus 100 Liquid Sampler system, are hidden for level 1 users (**User Level**), and revealed at level 2 (**Extended User Level**). The distinction between **User** and **Extended User Levels** contributes to the user friendliness of the TriPlus 100 Liquid Sampler system.

Besides being user-friendly, the distinction allows the **Extended User Level** to be reserved for a person responsible for the system, or for a specific group of users. This protection enhances the reliability of the system and the lab environment in which the TriPlus 100 Liquid Sampler system is used. Accidental changes can be minimized or avoided.

A third level, **Service**, is reserved for the service technician. This level is mainly used during the installation phase or when servicing the TriPlus 100 Liquid Sampler system. Accessing the **Service Level** requires a software key which is only provided for trained and authorized service technicians.

For details, please refer to:

- “[User Level](#)” on [page 47](#)
- “[Extended User Level](#)” on [page 48](#)
- “[Service Level](#)” on [page 49](#)



IMPORTANT Please note that the TriPlus 100 Liquid Sampler system is always started in the **User** access level.

If the **Extended User** mode is required, you have to change the access level. See [Changing Access Level](#).

User Level

The **User Level** is the normal working level recommended for routine use. This level is assigned as the default level.

The prerequisites for operating with the **User Level** are that the TriPlus 100 Liquid Sampler system has been completely assembled, the required active and passive modules are activated, and all positions have been taught to the system. The synchronization signals must be matched with the analytical system (for example: the Ready and Start signals).

The system must be completely installed, tested, and verified for the use in combination with the required GC system. When these prerequisites are fulfilled, and a routine run is to be started, the TriPlus 100 Liquid Sampler system is completely controlled by the Chromatography Data System (CDS).

With the **User Level**, specific menu items are specially marked as shown in the example of the Agitator pull-up menu **Options**. See the example in [Figure 28](#).

Figure 28. Example of User Level Pull-up Menu Options

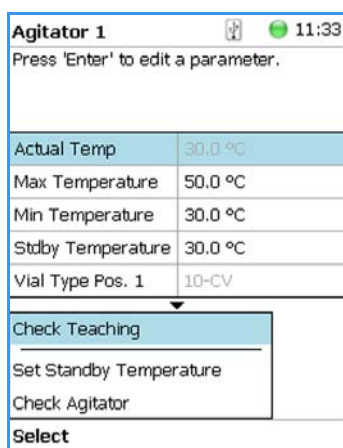

| Agitator 1 | |
|------------------------------------|---------|
| Press 'Enter' to edit a parameter. | |
| Actual Temp | 30.0 °C |
| Max Temperature | 50.0 °C |
| Min Temperature | 30.0 °C |
| Stdby Temperature | 30.0 °C |
| Vial Type Pos. 1 | 10-CV |
| ▼ | |
| Check Teaching | |
| Set Standby Temperature | |
| Check Agitator | |
| Select | |

You check parameters through the **Virtual Handheld Controller** or **Handheld Controller**. All other functionality, such as the number of samples, how to treat a sample, the injection technique, and so on, are under the control of the CDS.

Extended User Level

The **Extended User Level** provides the same basic functionality as the **User Level** but certain parameters of the Firmware can be controlled, such as those that may be used for new modules, X-,Y-,Z-axes position teaching, changing a sync signal, and so on. It is highly recommended that you operate the TriPlus 100 Liquid Sampler system in the **User Level** and only for special cases to activate the **Extended User Level**.

The **Extended User** access level provides the experienced operator more possibilities to interact with the TriPlus 100 Liquid Sampler system compared to the routine **User Level**. The distinction between the access levels enables the interface to be simplified for routine work, while providing the possibility to fine-tune the TriPlus 100 Liquid Sampler system according to the specific requirements of your particular applications.

With the **Extended User Level**, specific menu items are specially marked as shown in the example of the Agitator pull-up menu **Options**. See the example in [Figure 29](#).

Figure 29. Example of Extended User Level Pull-up Menu Options

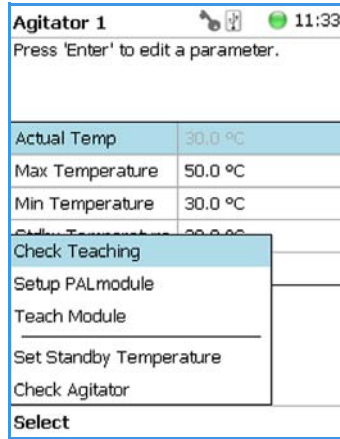

Service Level

The **Service Level** provides full access to the TriPlus 100 Liquid Sampler system. This level is reserved for qualified service engineers only. This level will be required for installation or any major repairs such as replacing a device (active module).

To open the **Service** access level, a software key is necessary. This key is provided on a Service USB stick, which is given to trained service engineers. The various menu items, accessible with **Service** rights, are described in the chapter “Setup Menu Item” on page 55.

Changing Access Level

Using the **Virtual Handheld Controller** the Access levels can be changed by pressing the two characters **A** and **B** simultaneously on the keyboard. See Figure 30.

Figure 30. Virtual Handheld Controller and Virtual Handheld Controller

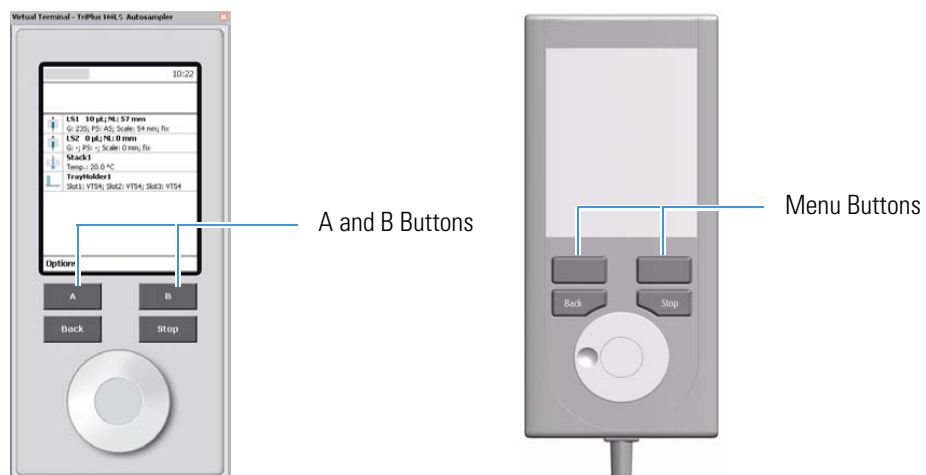

If the TriPlus 100 Liquid Sampler system is equipped with a Handheld Controller, press the two **Menu Buttons** simultaneously (see [Figure 30](#)) to access the screen as shown in [Figure 31](#). The **User Access Level** is the default level.

Figure 31. Changing Access Level

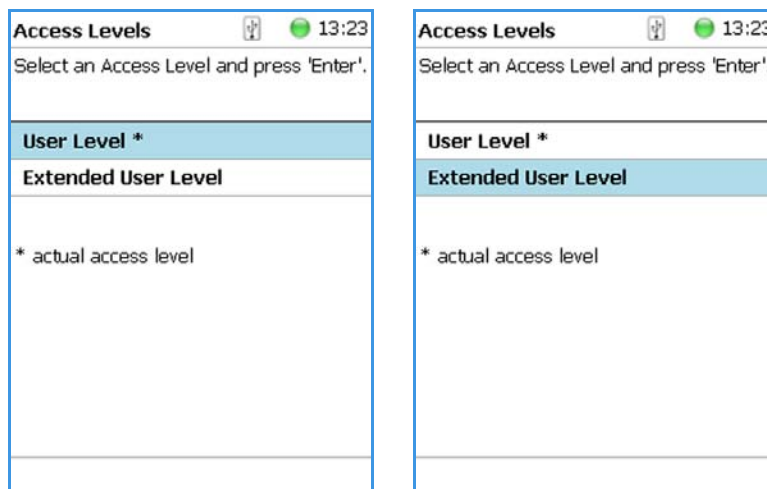

1. Select the required level and press **Enter** to activate it. The asterisk indicates the current active level.
2. When the **Extended User Access Level** is selected, a password can be set. See [Figure 32](#).

Figure 32. Selecting Extended User Level and Setting a Password

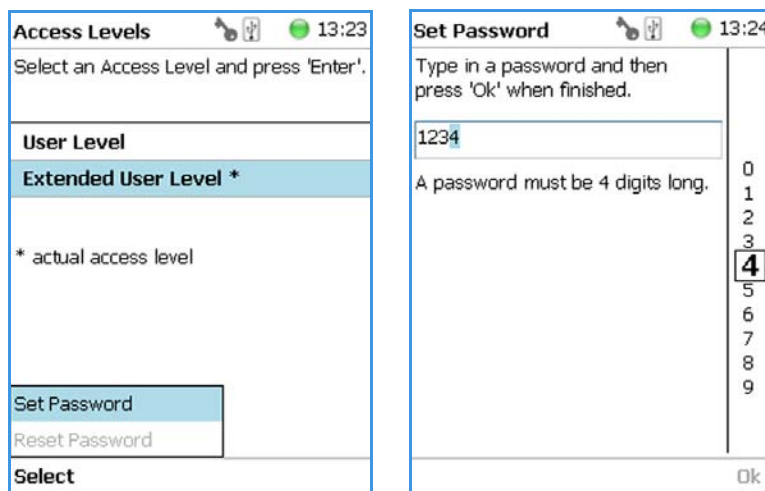

3. Select **Set Password** from the pull-up menu.
 - a. Place the cursor on the first digit and press the **Enter** button. A pop-up menu opens providing numerals from 0 to 9 for selection.
 - b. Accepting the password by pressing **Ok** stores it. The password can be changed or reset as long as you are working under the **Extended User Level**. See [Figure 33](#).

When the **User** level is active and you wish returning to the **Extended User Level**, follow the dialog shown in [Figure 33](#):

Figure 33. Entering Another Password to Access Extended User Level

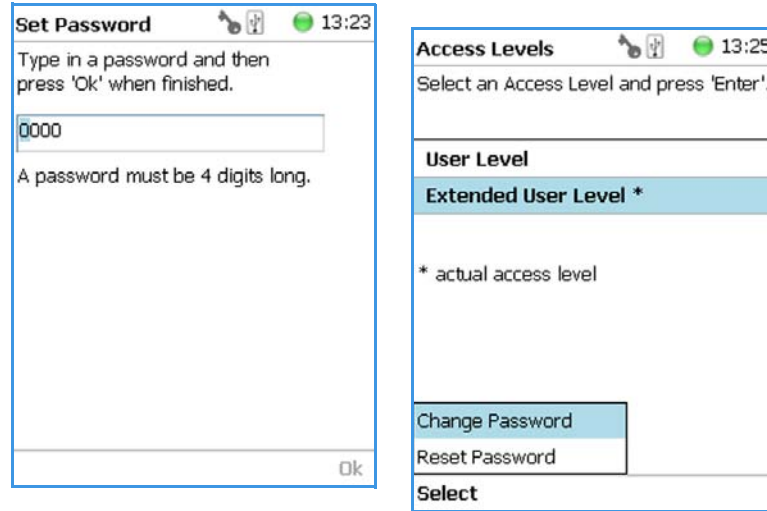

Please note that the **Ok** is grayed-out (inactive) as long as the correct password is not entered.

Note In case a password is forgotten, restore the **Firmware**. See **Firmware** in the *TriPlus 100 Liquid Sampler Hardware Manual*. Use a backup file which does not yet contain the password.

Be aware that changes made to the TriPlus 100 Liquid Sampler system or any changes in settings made after the installation of the backup file to recover the forgotten password will no longer be active.

A password cannot be set when operating under the **User Level**.

The **Service Level** is only accessible with the software key, provided on a Service USB stick. This key is provided to trained and authorized service technicians only.

Note If the Handheld Controller is not in use (Virtual Handheld Controller or Handheld Controller), a time-out function begins and after 60 minutes of inactivity the software reverts automatically to the default **User Level**.

Example of Differences in Access Levels

The main difference between the two access levels is that the menu item **Service** is not available in the **User** level. See [Figure 34](#).

Figure 34. Differences in Access Levels

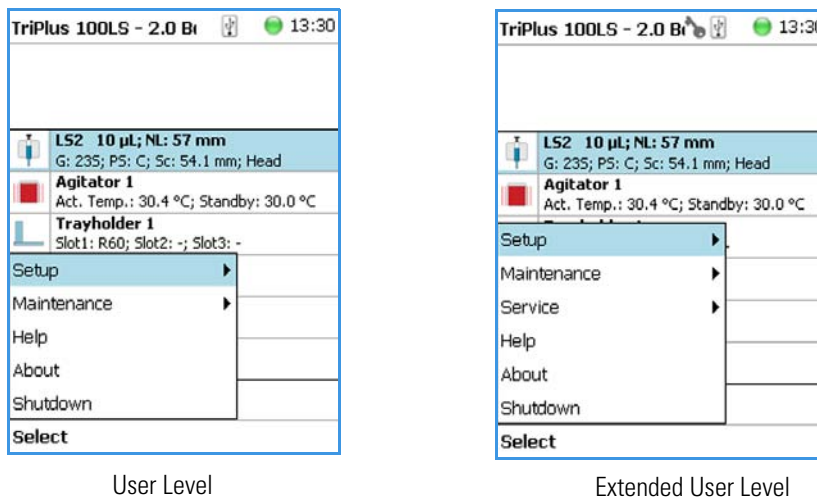

Note If the Handheld Controller (or the Virtual Handheld Controller) is not in use, a time-out function begins and after 30 minutes of inactivity the software reverts automatically to the default **User Level**.

Note that the TriPlus 100 Liquid Sampler system is always started in the **User** Access level. If the **Extended User** mode is required, you must change the access level. See “[User Level](#)” on [page 47](#).

Setup, Installation, and Maintenance Menu Item

The description of the options of the Firmware operated either with the Virtual Handheld Controller, or directly using the installed Handheld Controller are detailed in the following chapters:

- [Chapter 3, “Setup Menu Item.”](#)
- [Chapter 4, “Maintenance Menu Items.”](#)
- [Chapter 5, “Service Menu Item.”](#)

Help Menu Item

Figure 35 shows the rudimentary Handheld Controller functions.

Figure 35. Menu Item Help

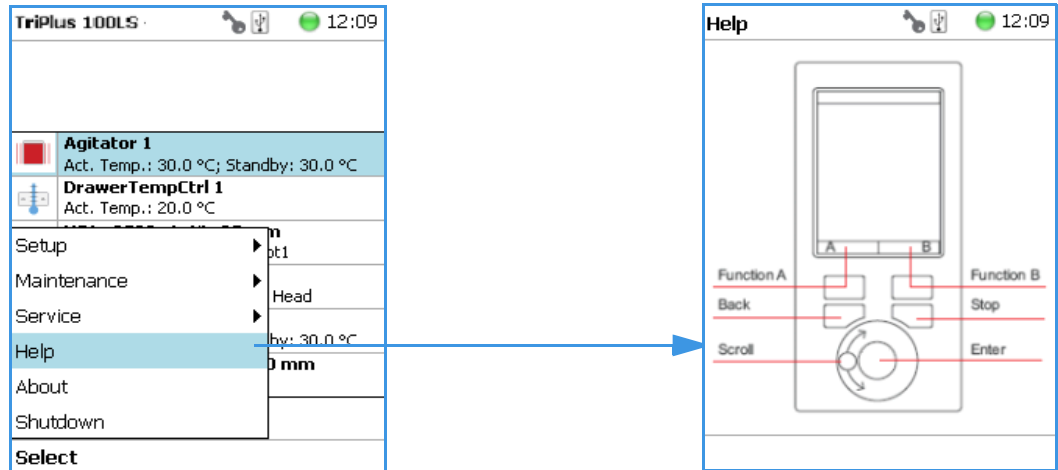

About Menu Item

This item informs you on which software versions are currently installed with the particular TriPlus 100 Liquid Sampler system. See Figure 36.

Figure 36. Menu Item About

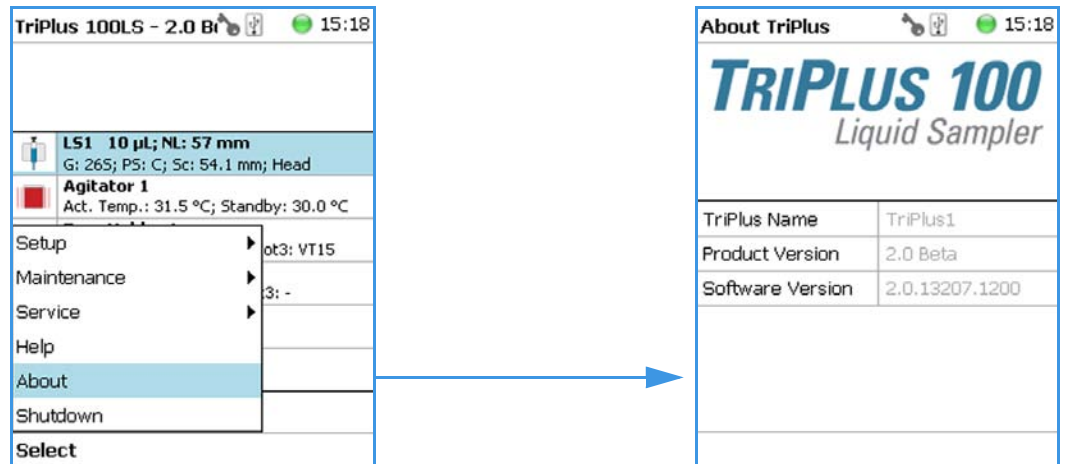

Shutdown Menu Item

The menu item **Shutdown** gives the operator the possibility to shut down the TriPlus 100 Liquid Sampler system in a controlled manner. See Figure 37.

2 TriPlus 100 Liquid Sampler Basic Information

Operation of the TriPlus System in Combination with Other Chromatography Data Systems

Figure 37. Menu Item Shutdown

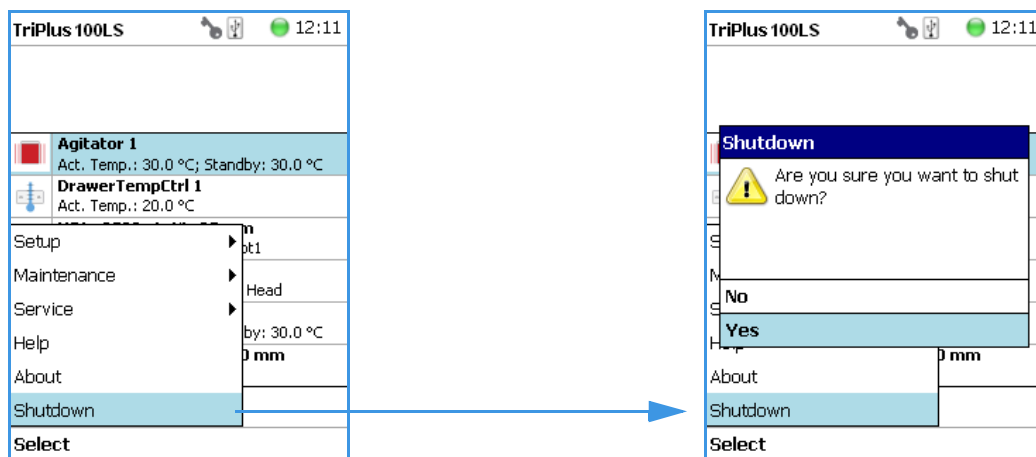

The main advantage of this automated shut down is that the Tool is parked. If the system is shut down by simply turning off the power supply, the slider will move very slowly downwards.

Parts of the Tool, particularly the syringe needle, can touch the bench surface, or any other object. This can damage the syringe needle.

After the TriPlus 100 Liquid Sampler system has completed the shutdown procedure, it is necessary to turn off the power at the power supply (switch at power).

To restart the TriPlus 100 Liquid Sampler system after the shutdown process, toggle the switch on the power supply, turn it off – wait about 30 seconds – then turn on the system power.

Operation of the TriPlus System in Combination with Other Chromatography Data Systems

For operation of the TriPlus 100 Liquid Sampler system with a Thermo Scientific Chromatography Data System (CDS), for example: Chromeleon, Xcalibur, ChromQuest, or Chrom-Card, a software driver is used. The specific requirements for operating the integrated System within the CDS are outlined by the supplier of the CDS software.

Setup Menu Item

This chapter describes the options of the **Setup Menu** operated either with the Virtual Handheld Controller, or directly using the installed Handheld Controller.

Contents

- Starting Setup Menu Item
- Setup Menu Item Modules
- Signals
- Setup Menu Item - Set Date and Time
- Setup Menu Item - Set TriPlus 100 Liquid Sampler Name
- Setup Menu Item - Setup Network

Note Items highlighted in **green** are only visible in the access level **Extended User**.

Starting Setup Menu Item

The Setup function is available under the **Options** pull-up menu. The **Extended User** access level provides limited higher functionality in **Setup** than in the restricted **User Level**.

The menu items are listed in alphabetical order.

Press the **Options** button to open the pull-up menu and select the menu item **Setup**. See [Figure 38](#).

Figure 38. Start Screen Options Pull-up Menu

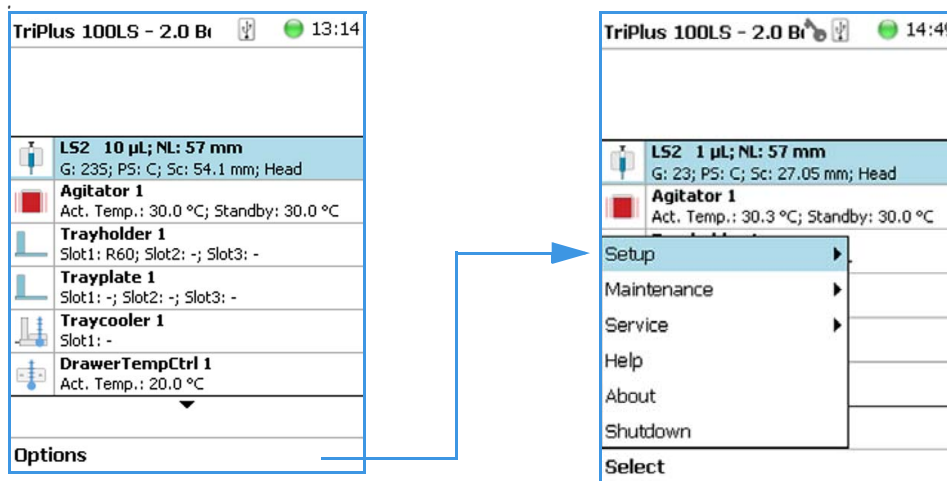

See the following sections for details:

- “Setup Menu Item Modules” on page 57
- “Setup Menu Item - Set Date and Time” on page 115
- “Setup Menu Item - Set TriPlus 100 Liquid Sampler Name” on page 116
- “Setup Menu Item - Setup Network” on page 116

Setup Menu Item Modules

Select the menu item **Modules** to open the list of all installed active and passive modules. See [Figure 39](#).

Figure 39. List of Active and Passive modules

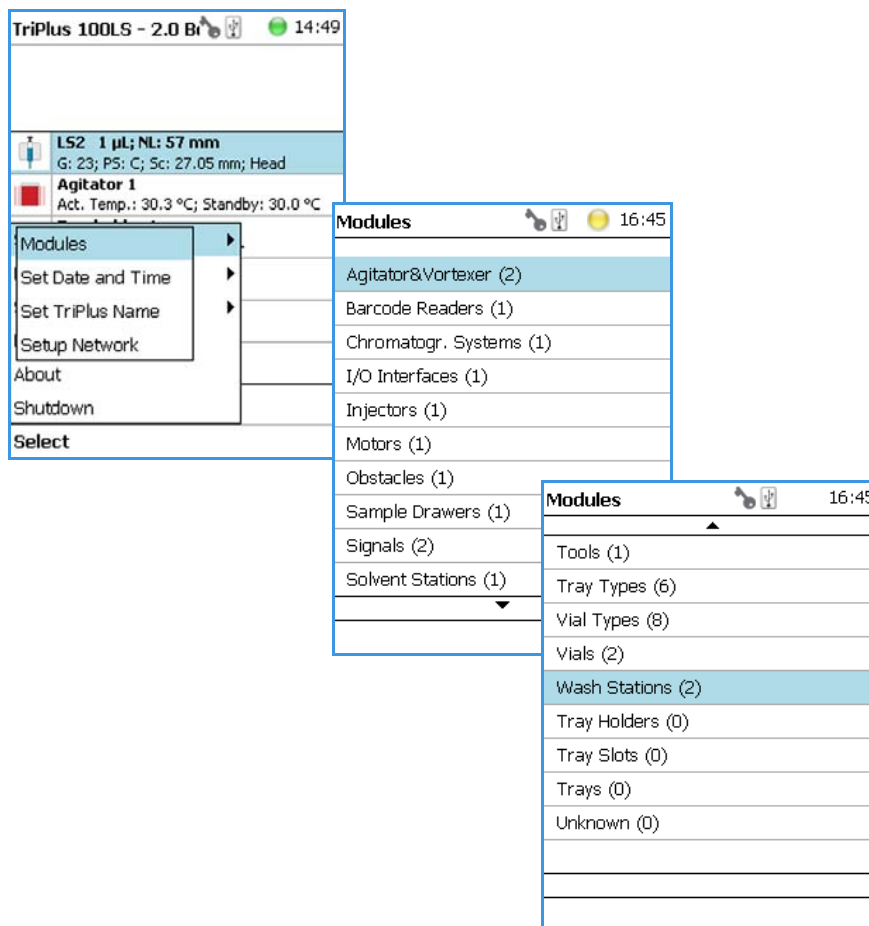

For details, refer to the following modules:

- “Agitator” on page 59
- “Vortexer” on page 63
- “Barcode Reader” on page 64
- “Chromatograph System” on page 66
- “Input/Output Interface” on page 67
- “Injectors” on page 70
- “Motors” on page 72
- “Obstacle” on page 74
- “Sample Drawers” on page 76
- “Signals” on page 80
- “Solvent Stations” on page 83
- “Syringe Types” on page 85
- “Tray Holders” on page 87
- “Tray Types” on page 90
- “Trays” on page 99
- “Vial Types” on page 102
- “Vials” on page 104
- “Wash Stations” on page 108
- “Tray Slots” on page 114
- “Unknown” on page 114

Agitator

Upon selecting the list item **Agitator & Vortexer**, the following parameters are available for modification. See [Figure 40](#).

Figure 40. Agitator Parameters

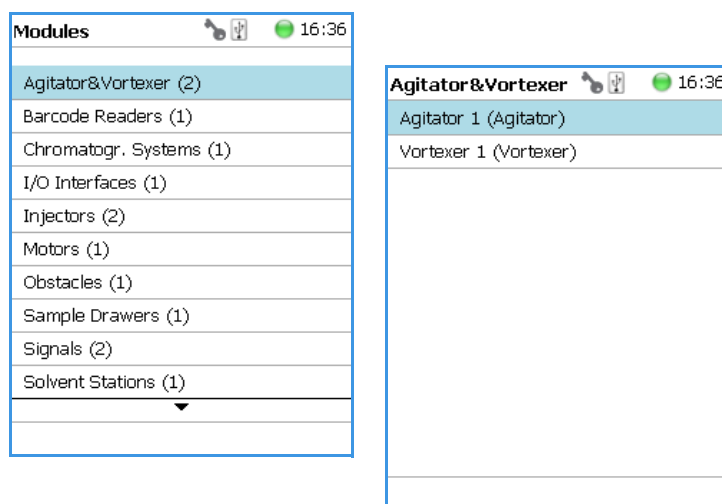

Select **Agitator**, then press **Enter** to edit a parameter. See [Table 22](#).

Table 22. Agitator Parameters (Sheet 1 of 2)

| Item | Description |
|---------------------|--|
| Actual Temperature | Reads out the actual temperature of the module; read-only function. |
| Max Temperature | Sets the upper temperature limit. The Maximum Temperature which can be set is 200 °C, but this parameter is often defined by the specific needs for the application. |
| Min Temperature | Sets the minimal temperature limit |
| Standby Temperature | The Standby Temperature can be adjusted to the application's requirements. Setting the Standby Temperature using this function does not yet activate the newly-selected temperature. To activate it, go to the pull-up menu Options and select Activate Standby Temperature . The Standby Temperature is activated when the TriPlus 100 Liquid Sampler system is powered up. In routine use, the Standby Temperature is activated after a job has been terminated. The Standby Temperature is typically lower than the application temperature. |

Table 22. Agitator Parameters (Sheet 2 of 2)

| Item | Description |
|--------------------|---|
| Vial Type Pos. 1 | The Vial Type for Position 1 is displayed. Read-only <i>The Vial Type can be set with the task Setup Module.</i> |
| Vial Type Pos. 2 | The Vial Type for Position 2 is displayed. Read-only. <i>The Vial Type can be set with the task Setup Module.</i> |
| Vial Type Pos. 3 | The Vial Type for Position 3 is displayed. Read-only. <i>The Vial Type can be set with the task Setup Module.</i> |
| Vial Type Pos. 4 | The Vial Type for Position 4 is displayed. Read-only. <i>The Vial Type can be set with the task Setup Module.</i> |
| Vial Type Pos. 5 | The Vial Type for Position 5 is displayed. Read-only. <i>The Vial Type can be set with the task Setup Module.</i> |
| Vial Type Pos. 6 | The Vial Type for Position 6 is displayed. Read-only. <i>The Vial Type can be set with the task Setup Module.</i> |
| Cover Plate Type | Select the cover plate (lid) used for the agitator installed. <ul style="list-style-type: none"> • Not Specified — An execution of the run is prohibited. • Standard: The lid must be opened for access. • Perforated: Syringe needle can be inserted through the holes in the lid. |
| Actual Position | Reads out the position of the Agitator. Read-only function. |
| Stdby Temp Control | If switched off, the module will not go to standby temperature if idle. |
| Temp Gain | The coefficient used, if a temperature calibration has been performed. Possible values are between 0 and 2. Read-only. |
| Temp. Offset | The Offset temperature used, if a temperature calibration has been performed. Possible values are between -10 °C and +10 °C. Read-only. |

Note A job is often described as a sample list or sequence which is treated in a certain order. A job can also contain a single sample, often seen in method development work. In such cases, you set the Standby Temperature to the same temperature used for the application. Dropping the temperature during runs can be time-consuming and disruptive.

Agitator Options Pull-up Menu

Selecting the pull-up menu **Options** opens up following tasks. See [Table 23](#).

Table 23. Agitator Pull-up menu Options

| Item | Description |
|-------------------------|--|
| Check Teaching | Checks the teaching position of the module. This task serves as a quick check to determine if the X-, Y-, and Z-positions are defined correctly. In case a teaching point is off, return to the Menu Setup for readjustment of the teaching position. Please note that this action can be done under the Extended User Level but not under User Level . |
| Setup Module | This task allows to select the Cover Plate Type , to reserve one or more vials as a source vial (for example for a reagent), and to define the Vial Type for the 6 positions. See Detailed Description of Setup Module, Reserved Position, and Vial Type Parameters . |
| Teach Module | The positions of the X-, Y-, and Z-axes can be defined again, teaching. |
| Set Standby Temperature | Activates the newly-set Standby Temperature. |
| Check Agitator | Starts the spinning motion of the Agitator. It is used to test the Agitator function, or the spinning speed for particular application. Settings are: <ul style="list-style-type: none"> • Options: On; Off; Home • Speed: Select the required speed, range 250 rpm to 750 rpm Press Run to start the Agitator. To stop the motion, press Options again, select Check Agitator and set the parameter Options to Off . Press Run . |

Detailed Description of Setup Module, Reserved Position, and Vial Type Parameters

With the list item **Setup Module** it is possible to reserve one or more positions in the Agitator for a source vial; as for example, to be able to provide an internal standard solution, a reagent solution for a derivatization, or any other solution as require by a specific application. The reservation for a vial starts with **Vial Position 6** and counts backwards. This way are the first positions are available for sample vials. The vial size is selectable for the free available positions and separately for the reserved vials(-s). Please note that for the reserved vials is only one vial size is selectable.

The effect in the routine work is that a vial overlapping, to optimize the throughput, will be possible only within the free available sample vial positions.
The behavior of the two **Activities** from the script language has to be mentioned in this context:

- Activity **TransportVial**: Allowed for free available and for reserved vial positions.
- Activity **MoveToObject**: Allowed for **reserved** vial positions only.

The reason for the limitation is because in the overlapping mode is the sample vial position managed by the scheduler. Examples of Free available and Reserved Vial Positions are shown in [Figure 41](#).

Figure 41. Example of Free available and Reserved Vial Pod

The figure consists of six screenshots of the instrument's menu system, arranged in two rows of three. Each screenshot shows a different configuration of reserved vial positions in a 2x3 vial pod.

Screenshot 1 (Top Left): Shows the 'Setup Modules' menu for 'Agitator 1'. The 'Reserved Positions' is set to 0. The table below shows Vial Type Pos. 1-6 all set to 20-CV. The vial pod diagram shows all 6 positions available.

| | |
|--------------------|----------|
| Cover Plate Type | Standard |
| Reserved Positions | 0 |
| Vial Type Pos. 1-6 | 20-CV |

Reserved Positions: None

Screenshot 2 (Top Middle): Shows the 'Agitator 1' menu. The table shows Vial Type Pos. 1-5 set to 20-CV. The vial pod diagram shows positions 1-6 available.

| | |
|------------------|-------|
| Vial Type Pos. 1 | 20-CV |
| Vial Type Pos. 2 | 20-CV |
| Vial Type Pos. 3 | 20-CV |
| Vial Type Pos. 4 | 20-CV |
| Vial Type Pos. 5 | 20-CV |

Vial Positions 1-6 available

Screenshot 3 (Top Right): Shows the 'Setup Modules' menu for 'Agitator 1'. The 'Reserved Positions' dropdown is open, showing options: 1 (Pos. 6), 2 (Pos. 5-6), and 3 (Pos. 4-6). The table shows Vial Type Pos. 1-6 set to 20-CV. The vial pod diagram shows position 6 reserved.

| | |
|--------------------|----------|
| Cover Plate Type | Standard |
| Reserved Positions | 0 |
| Vial Type Pos. 1-6 | 20-CV |

Reserved Positions: Position 6

Screenshot 4 (Bottom Left): Shows the 'Agitator 1' menu. The table shows Vial Type Pos. 3-5 set to 20-CV, Vial Type Pos. 6 set to R20-CV, and Actual Position set to 0 rad. The vial pod diagram shows positions 1-5 available.

| | |
|------------------|--------|
| Vial Type Pos. 3 | 20-CV |
| Vial Type Pos. 4 | 20-CV |
| Vial Type Pos. 5 | 20-CV |
| Vial Type Pos. 6 | R20-CV |
| Actual Position | 0 rad |

Vial Positions 1-5 available

Screenshot 5 (Bottom Middle): Shows the 'Setup Modules' menu for 'Agitator 1'. The 'Reserved Positions' dropdown is open, showing options: 1 (Pos. 6), 2 (Pos. 5-6), 3 (Pos. 4-6), and 4 (Pos. 3-6). The table shows Vial Type Pos. 1-5 set to 10-CV and Vial Type Pos. 6 set to R20-CV. The vial pod diagram shows positions 4-6 reserved.

| | |
|--------------------|----------|
| Cover Plate Type | Standard |
| Reserved Positions | 0 |
| Vial Type Pos. 1-5 | 10-CV |
| Vial Type Pos. 6 | R20-CV |

Reserved Positions: Position 4-6

Screenshot 6 (Bottom Right): Shows the 'Agitator 1' menu. The table shows Vial Type Pos. 1-3 set to 10-CV, Vial Type Pos. 4 set to R20-CV, and Vial Type Pos. 5 set to R20-CV. The vial pod diagram shows positions 1-3 available.

| | |
|------------------|--------|
| Vial Type Pos. 1 | 10-CV |
| Vial Type Pos. 2 | 10-CV |
| Vial Type Pos. 3 | 10-CV |
| Vial Type Pos. 4 | R20-CV |
| Vial Type Pos. 5 | R20-CV |

Vial Positions 1-3 available, Vial Size 10 mL
Positions 4-6 Reserved, Vial Size 20 mL

Vortexer

Upon selecting the list item **Agitator & Vortexer**, the following parameters are available for modification. See [Figure 42](#).

Figure 42. Vortexer Parameters

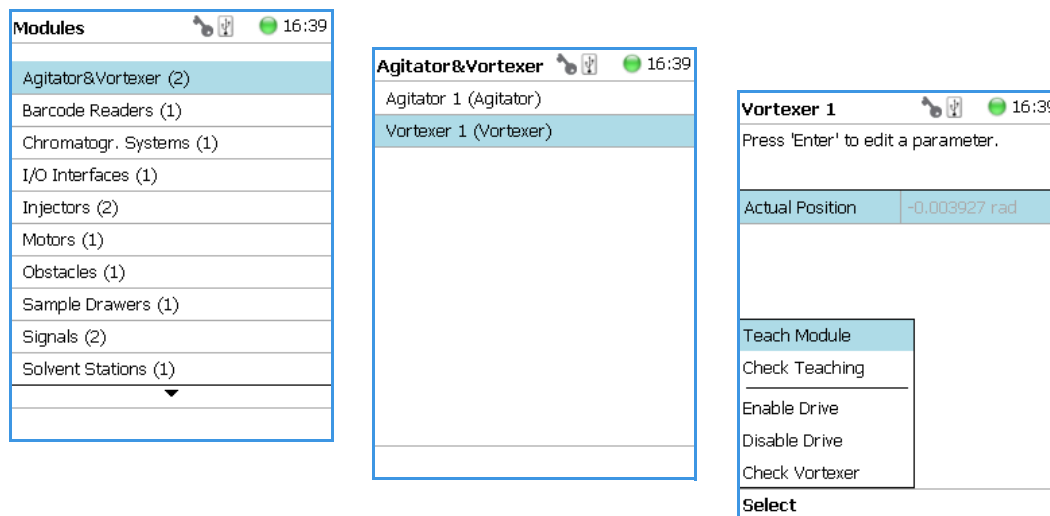

Select **Vortexer**, then press **Enter** to edit a parameter. See [Table 24](#).

Table 24. Vortexer Parameters

| Item | Description |
|-----------------|---|
| Actual Position | Reads out the position of the Agitator; read-only function. |

Vortexer Options Pull-up Menu

Selecting the pull-up menu **Options** shows the following tasks. See [Table 25](#).

Table 25. Vortexer Pull-up Menu Options (Sheet 1 of 2)

| Item | Description |
|----------------|--|
| Check Teaching | Checks the teaching position of the module. This task serves as a quick check to determine if the X-, Y-, and Z-positions are defined correctly. In case a teaching point is off, return to the Menu Setup for readjustment of the teaching position. Please note that this action can be done under the Extended User Level but not under User Level . |
| Teach Module | The positions of the X-, Y-, Z-axes can be defined again, teaching. |
| Enable Motor | Enables the motor of the vortexer |

Table 25. Vortexer Pull-up Menu Options (Sheet 2 of 2)

| Item | Description |
|----------------------|--|
| Disable Motor | Disables the vortexer motor. |
| Check Vortexer | <p>Starts the spinning motion of the Vortexer. It is used to test the mixer function or the spinning speed for particular application.</p> <p>Settings are:</p> <ul style="list-style-type: none"> • Option — On; Off; Home • Speed — Select the required speed, range 250 to 2500 rpm <p>Press Run to start the Vortexer.</p> <p>To stop the motion, press Options again, select Check Vortexer and set the parameter Option to Off. Press Run.</p> |

Barcode Reader

Upon selecting the list item **Barcode Reader**, the following parameters are available for modification. See [Figure 43](#).

Figure 43. Barcode Reader Parameters

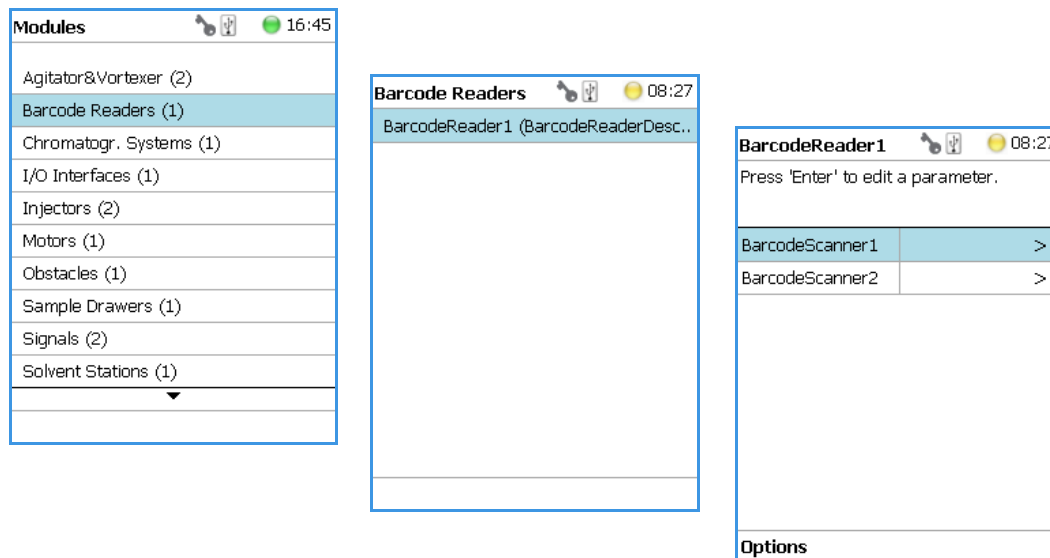

Press **Enter** for editing the parameters. See [Table 26](#).

Barcode Reader Option Pull-up Menu

Barcode Reader Parameters are listed in [Table 26](#).

Table 26. Barcode Reader Parameters

| Item | Description |
|-------------------|--|
| Scanner | Select Scanner #1 or #2. |
| Beep After Decode | A beep tone can be activated after positive decoding of the barcode. |

Selecting the pull-up menu **Options** opens up the following tasks. See [Table 27](#).

Table 27. Options Menu Item Check Teaching

| Item | Description |
|----------------|--|
| Teach Module | The positions of the X-, Y-, and Z-axes can be defined again, teaching. |
| Check Teaching | Checks the teaching position of the module. This task serves as a quick check to determine if the X-, Y-, and Z-positions are defined correctly. In case a teaching point is off, return to the Menu Setup for readjustment of the teaching position. Please note that this action can be done under the Extended User Level but not under User Level . |
| Scan Barcode | Checks the Barcode Reader. Hold a barcode label in the beam of the laser and activate Scan Barcode . A beep tone signals a successful reading |

Chromatograph System

The **Chromatograph System** is a bundle of **Input and Output Signals** dedicated for a chromatographic system. This bundle must be configured and can be assigned to a specific chromatographic system for routine use. This minimizes erroneous functions and simplifies the user interface.

This is the last step in the setting up and synchronization of **Input/Output Signals** between the system and the external device. See also the section “**Input/Output Interface**” on page 67, and the section “**Signals**” on page 80.

Upon selecting the list item **Chromatograph System**, the following parameters are available for modification. See Figure 44.

- **GC1** = Name for GC System No.1
- **(GC)** = Class description GC System

Figure 44. Chromatography System - Selection and Parameters

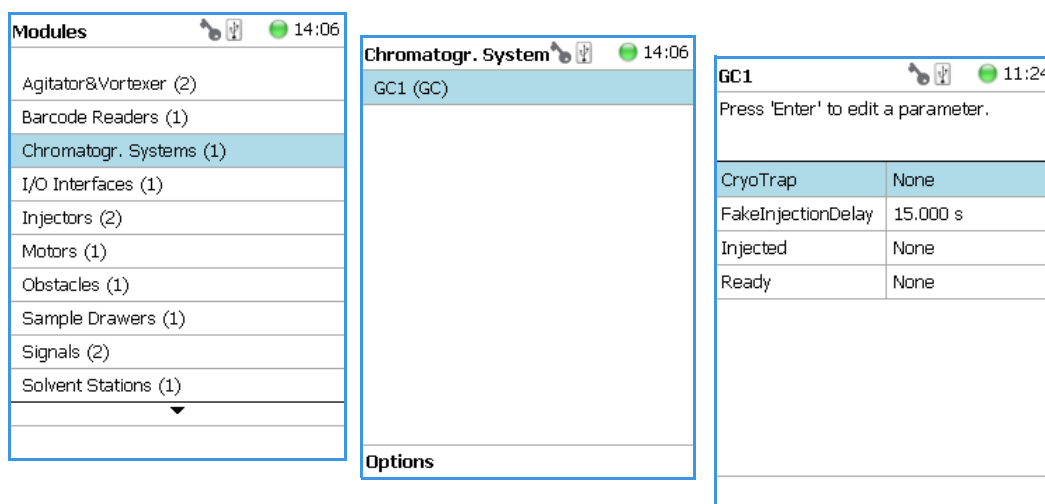

Press **Enter** to edit a parameter. See Table 28.

Table 28. Chromatography System Parameters

| Item | Description |
|----------------------|--|
| Cryo Trap | Set start signal for the Cryo Trap, Output signal required. |
| Fake Injection Delay | Sets the delay time until the start of a fake injection. A fake injection performs a start of the chromatographic system, without injection of a sample. |
| Injected | Set start signal for the chromatographic system, for example GC System1. Output Signal is required. |
| Ready | A ready signal from another device is expected as an Input Signal. |

Note The synchronization between the TriPlus 100 Liquid Sampler system and any chromatographic system has to be checked for each particular system configuration. The setting of the synchronization signal has to be matched with the pin allocation of the synchronization cable.

The original cable are labeled. Check the labels first before connecting. This is especially important with the Y-cable configurations where two GC units are connected to a single TriPlus 100 Liquid Sampler system.

Chromatograph System Options Pull-up Menu

Selecting the pull-up menu **Options** opens up the following tasks. See [Table 29](#).

Table 29. Chromatography System Pull-up Menu Options

| Item | Description |
|--------------------------|---|
| New Chromatograph System | Creates a new Chromatograph System. |
| Copy GC | Copies the Chromatograph System, GC1 as the example. |
| Delete GC | Deletes the Chromatograph System; GC1 as the example. |

Input/Output Interface

This section provides the signal settings and synchronization to the external device, such as a GC System. See [Figure 45](#).

It is the second step in the setting up and synchronization of Input/Output Signals between the system and the external device.

Figure 45. Menu Item for Input/Output Interface

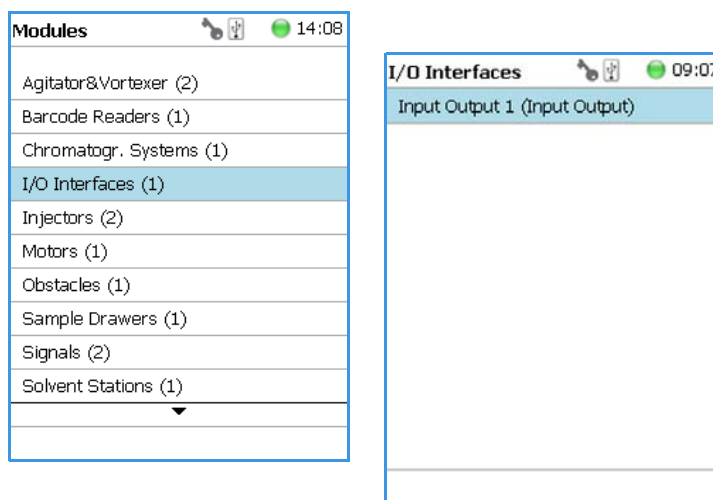

Press **Enter** to edit a parameter.

Upon selecting the list item **I/O Interface**, the following parameters are available for modification. See [Table 30](#).

Table 30. List of Items for Input and Output Signals (Sheet 1 of 2)

| Item | Description |
|---|--|
| List Items for I/O Interface | |
| Immediate <i>Ignores any Input or Output Signal</i> | Signal On Debounce Time |
| Opto In1 <i>Opto-isolator or Opto-coupler</i> | Signal On Debounce Time Negative Logic |
| PWM Out <i>Pulse-Width Modulation</i> | Signal On Output Voltage |
| Reset Button <i>Reset Button on Control Board (blue)</i> | Signal On Debounce Time Negative Logic |
| Simulated <i>This signal can be used for testing, simulation of sending a signal (Output Signal)</i> | Signal On Trigger Event Waiting Time |
| SW Out1 <i>Switch-out Signal, Relay contact</i> | Signal On Low Active |
| SW Out2 <i>Switch-out Signal, Relay contact</i> | Signal On Low Active |
| TTL In1 <i>Transistor-Transistor Logic</i> | Signal On Debounce Time Low Active |
| TTL In2 <i>Transistor-Transistor Logic</i> | Signal On Debounce Time Low Active |
| TTL In3 <i>Transistor-Transistor Logic</i> | Signal On Debounce Time Low Active |
| TTL Out1 <i>Transistor-Transistor Logic</i> | Signal On Low Active |
| TTL Out2 <i>Transistor-Transistor Logic</i> | Signal On Low Active |
| TTL Out3 <i>Transistor-Transistor Logic</i> | Signal On Low Active |
| Beep Volume | Selectable on scale from 1 to 5. |

Table 30. List of Items for Input and Output Signals (Sheet 2 of 2)

| Item | Description |
|---|--|
| List Item Parameters for I/O Signals | |
| Debounce Time | Specifies how long the signal is applied. |
| Low Active | A standby status of a signal from the chromatographic system can be High Active or Low Active . Depending on what has to be applied for the specific system, one has to match the signal logic on the TriPlus 100 Liquid Sampler system side. By setting a mark to Low Active means that Low Active is selected. Low Active disabled means High Active selected. Information for the required signal logic is provided with the schematic of the sync cable which is part of the GC mounting kit. |
| Signal On | The term Signal On means that the signal has been sent or received. |
| Output/Voltage | An output voltage in range of 0 to 35 V can be selected. |
| Trigger Event | Select the desired type of output signal for testing. |
| Waiting Time | Select the time to be waited until the signal is activated, delay time in seconds. |
| Beep Volume | The sound volume for the Beep tone can be selected. |

Input/Output Interface Pull-up Menu

Selecting the pull-up menu **Options** from the list item **Beep Volume** opens up to the following tasks. See [Table 31](#).

Table 31. Option Pull-up Menu for Input/Output Interface (Sheet 1 of 2)

| Item | Description |
|------------------|---|
| Reset to Default | Resets the selected module parameter to default value. |
| Beep | Activates a Beep sound local on TriPlus 100 Liquid Sampler system. If activated, the operator can select the Duration , Frequency , and the Volume of the tonal sound. |
| Duration | The time for the tonal sound is selectable from 100 ms to 60 seconds. |

Table 31. Option Pull-up Menu for Input/Output Interface (Sheet 2 of 2)

| Item | Description |
|--------------|--|
| Frequency | The frequency of the tonal sound is selectable from 100 to 10000 Hz. |
| Run | Activates the tonal sound with the selected parameters for testing. |
| Beep Utility | Sets the frequency and the time length of the beep tone. |

From all other list parameters the pull-up menu **Beep** is directly available.

Injectors

Upon selecting the list item **Injectors**, the following parameters are available for modification. See [Figure 46](#).

Figure 46. Injectors - Selection and Parameters

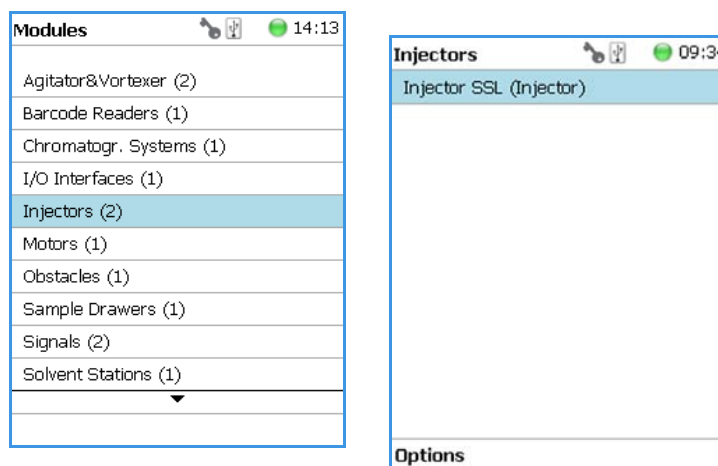

Press **Enter** to edit a parameter. See [Table 32](#).

Table 32. Injector Parameters (Sheet 1 of 2)

| Item | Description |
|----------------------------------|--|
| Default Needle Penetration Depth | Defines the Needle Penetration Depth in the injector. |
| Max Needle Penetration Depth | Sets the upper limit of Needle Penetration Depth into the injector. |

Table 32. Injector Parameters (Sheet 2 of 2)

| Item | Description |
|--------------------|---|
| Position Tolerance | <p>Checks the difference between the taught X-Y-Axes positions against the actual position each time the head moves to the GC Injector. If the difference is greater than the Position Tolerance of 3.0 mm (default value) then the TriPlus 100 Liquid Sampler system immediately stops. This is a safety feature to avoid needle bending.</p> <p>WARNING It is highly recommended to check the teaching positions of the injectors again when the GC is ready (heated up to the level as used for routine runs).</p> |
| Z Tolerance | <p>A tolerance window to give a plus/minus range (expressed in mm) in which the Head must expect an object.</p> <ul style="list-style-type: none"> • If the value of this item is > 0, indicates a relative detection mode is triggered, and the sensor from the Head needle guide is active. • If the value of this item is set to 0, the sensor of the needle guide is turned off and the syringe slider moves to an absolute value: the Z-axis position as specified for the object. |

Injectors Options Pull-up Menu

Selecting the pull-up menu **Options** opens up the following tasks. See [Table 33](#).

Table 33. Option Menu for Injectors

| Item | Description |
|------------------|---|
| Reset to Default | Resets the selected module parameter to default value. |
| Check Teaching | <p>Checks the teaching position of the module. This task serves as a quick check to determine if the X-, Y-, and Z-positions are defined correctly. In case a teaching point is incorrect, return to the Menu Setup for readjustment of the teaching position.</p> <p>Please note that this action can be done under the Extended User Level but not under User Level.</p> |
| Teach Module | The positions of the X-, Y-, and Z-axes can be defined again, (teaching). |

Motors

Upon selecting the list item **Motors**, the following parameters are available for modification. See [Figure 47](#).

Figure 47. Motors Menu

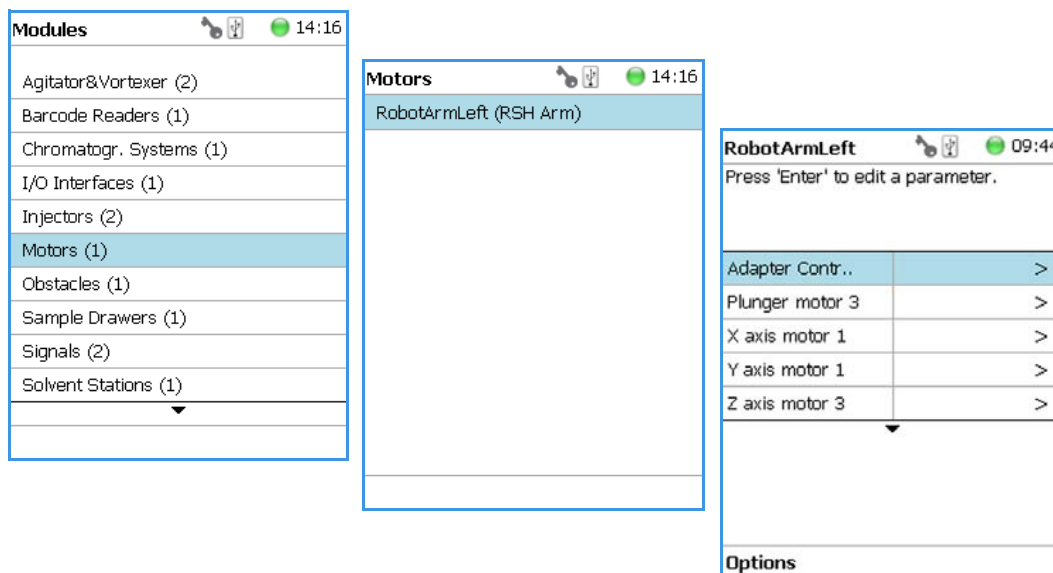

Press **Enter** to edit a parameter. See [Table 34](#).

Table 34. List of Motors (Sheet 1 of 2)

| Item | Description |
|-----------------|--|
| Adapter Control | <p>LS (Liquid Syringe) Parameters:</p> <p>Instrument Length — Defines total length of the syringe (instrument). Read-only function.</p> <p>Length — Defines total length of the Syringe Adapter. Read-only function.</p> <p>Ndl Guide Type — Defines if an adapter such as the magnetic ring or the foil cutter is attached he Needle Guide.</p> <p>IMPORTANT The Needle Guide Type must be defined; the default value is NotSpecified. For more details see the section “Installation Item” on page 129.</p> <p>Syringe Type — All syringes with the same geometry (barrel diameter, needle length) and type used with Syringe Adapter are pre-selected by the firmware and are selectable for use.</p> |

Table 34. List of Motors (Sheet 2 of 2)

| Item | Description |
|--------------------------------|--|
| Plunger Motor (#) (Motor W) | Actual position — Reads only for information Check Plunger — Checks the presence of the plunger. |
| X Motor (#) | Actual position — Reads only for information Length X-axis — Selects the length of the 850 mm X-axis |
| Y Motor (#) | Actual position — Reads only for information |
| Z Motor (#) | Actual position — Reads only for information |
| Default Strategy | Defines of the global movement of the Head across the system platform. The following selections are possible: <ul style="list-style-type: none"> • Parallel — Allows simultaneously movement of all axes. This mode is the default mode. When operating the TriPlus 100 Liquid Sampler system in this mode, the positions and heights of the known modules are respected. The TriPlus 100 Liquid Sampler system changes the strategy automatically. For example, if one module is higher than another, the TriPlus 100 Liquid Sampler system would lower the Z-axis to the zero position to allow the modules to cross over. If an external object is within the platform, for example a GC Detector, then the X-, Y-, and Z-positions of this potential obstacle are not known to the TriPlus 100 Liquid Sampler system. In such a case, it is necessary to switch the strategy to Safe mode. • Safe — The Y-axis moves from any point first to zero Y (back to the X-axis) before the X-movement is started. This mode allows bypassing of an object (such as a large GC detector) that would be directly in the travel path if the Parallel mode is used. |
| Default Waste | This parameter selects the corresponding Wash Module installed. IMPORTANT A Wash Module must be defined; the default value is None . The selection allows to define one of the following Wash Modules: Fast Wash Module, Large Wash Module, or Standard Wash Module. |

Motors Pull-up Menu Options

Selecting the pull-up menu **Options** opens up the following tasks. See [Table 35](#).

Table 35. Option Pull-up Menu for Motors

| Item | Description |
|-------------------------|--|
| Calibrate Motors | Calibrates the motors. This task might be necessary after a motor has been disconnected. This is a recovery feature. See “Calibrate Motors” on page 138. |
| Exchange Syringe | Allows moving the head to the defined position to change the syringe conveniently. |
| Teach Exchange Position | Allows defining the syringe Exchange Position. |
| Teach Home Position | Allows a Home Position of the head to be defined, which can be at any X-, Y-, or Z-position. |
| Teach Shutdown Position | Allows defining the position where the head shall move before the shutdown of the system is activated. |
| Home Head | Moves the Head to Home position and references all axes. |
| Disable Head | All axes are electrically isolated, enabling the operator to move the axes manually. |
| Enable Head | The axes (motors) are reconnected to mains again. |
| Move to Home | Moves the Head back to Home position, without referencing the axes. |
| Reset to Default | Resets the selected module parameter to default value |

Obstacle

The object **Obstacle** is a module from another device, for example a large Thermal Conductivity Detector (TCD). If a module exceeds a certain height, it could get in the path way of the TriPlus 100 Liquid Sampler system.

The dimensions and the position of the Obstacle can be defined. The TriPlus 100 Liquid Sampler system will exclude this area from the allowed path way and will bypass it.

The following parameters are available for modification. See [Figure 48](#).

Figure 48. Obstacle - Selection and Parameters

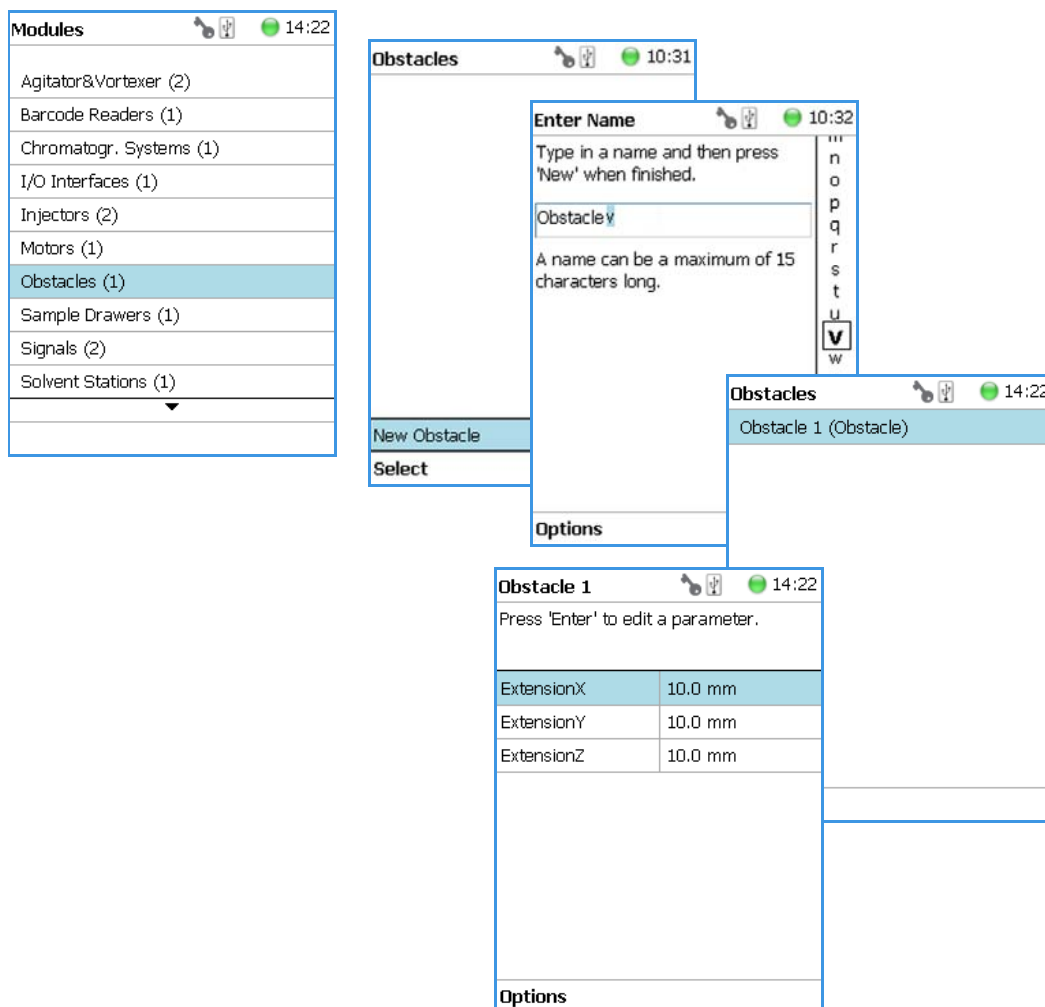

Press **Enter** to edit a parameter. See [Table 36](#).

Table 36. Obstacle Parameters

| Item | Description |
|-------------|---|
| Extension X | Extension from the center point of the Obstacle in X-axis direction. |
| Extension Y | Extension from the center point of the Obstacle in Y-axis direction. |
| Extension Z | Extension from the center point of the Obstacle in Z-axis direction. |

Obstacle Options Pull-up Menu

Selecting the pull-up menu **Options** opens up the following tasks. See [Table 37](#).

Table 37. Obstacle Option Parameters

| Item | Description |
|------------------|--|
| New Obstacle | Creates a new obstacle. |
| Copy Obstacle | Copies the present obstacle. |
| Delete Obstacle | Deletes the present obstacle. |
| Reset to Default | Resets the selected module parameter to default value. |
| Check Teaching | Checks the teaching position of the module. This task serves as a quick check to determine if the X-, Y-, and Z-positions are defined correctly. In case a teaching point is incorrect, return to the Menu Setup for readjustment of the teaching position. Please note that this action can be done under the Extended User Level but not under User Level . |
| Teach Module | The positions of the X-, Y-, and Z-axes can be defined again, (teaching). |

Sample Drawers

Note The Temperature Controlled Drawer can be adjusted through the BUS protocol. For the power supply it is mandatory to use a second Power Module. Do not use the same power supply as used for the TriPlus 100 Liquid Sampler system.

Selecting the list item **Sample Drawers** opens up the following parameters. See [Figure 49](#).

Figure 49. Menu Item Temperature Controlled Drawer and Menu List Item Stack

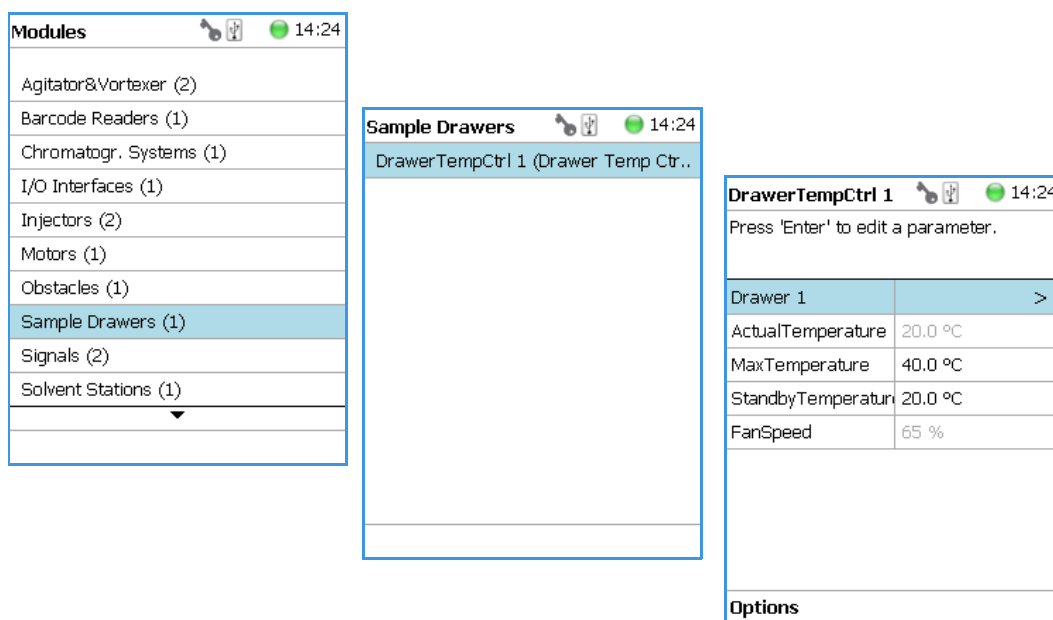

Press **Enter** to edit a parameter. See [Table 38](#).

Table 38. Stack Module Parameters (Sheet 1 of 2)

| Item | Description |
|---------------------|---|
| Drawer 1 | Press Enter to access the list items Drawer State , Slot Count , and so on. |
| Actual Temperature | This parameter is for information only. |
| Max Temperature | The Maximum Temperature which can be set is 40 °C, but this parameter is often defined by your specific needs. |
| Min Temperature | Sets the minimum temperature. |
| Standby Temperature | <p>The Standby Temperature can be adjusted according to the application's requirements. Setting the Standby Temperature using this function does not yet activate the newly-selected temperature. To activate it, go to the pull-up menu Options and select Set Standby Temperature.</p> <p>The Standby Temperature is activated when the TriPlus 100 Liquid Sampler system is powered up. In routine use, the Standby Temperature is usually activated after a job has been terminated. The Standby Temperature is typically around ambient temperature; this helps to dry out the internal parts of a Temperature Controlled Drawer, thus eliminating condensation.</p> |
| CloseSpeed | The speed for closing the drawer can be adapted to a value between 15 and 100%. (The default value is 80%.) |
| OpenSpeed | The speed for opening the drawer can be adapted to a value between 15 and 100%. (The default value is 80%). |
| Fan Speed | Shows read-only information, and can be used for diagnostic purposes. |
| Stdby Temp Control | If switched off, the module will not go to standby temperature if idle. |
| Temp. Gain | The coefficient used, if a temperature calibration has been performed. Possible values are between 0 and 2. Read-only. |
| Temp. Offset | The Offset temperature used, if a temperature calibration has been performed. Possible values are between -10 °C and +10 °C. Read-only. |

Table 38. Stack Module Parameters (Sheet 2 of 2)

| Item | Description |
|--|---|
| In the field Stack Drawer | <ul style="list-style-type: none"> • Slot1 to Slot2 — Defines the position of the Tray. See “Assigning a Tray Type to the Slot” on page 79. • Drawer Status — Displays the status of the Stack Drawer position. The following positions are possible: <ul style="list-style-type: none"> – Closed – Half Open = middle position – Opening = fully opened drawer. Status Opening indicates an error. Readout functions only. • SlotCount — Indicates the total number of Slots available in the Stack Module. • Magnet Location — It is possible to use either the magnet plate on the right-hand side or the magnet plate on the left-hand side of the drawer for opening and closing. The actual setting is displayed. |
| In the field Slot (Rack or Well Plate) | <ul style="list-style-type: none"> • Cap Type — Read only parameter • RackType — Defines the pattern and sampling sequences of sample locations within a Rack. • WellPlate Type — Defines the pattern and sampling sequences of sample locations within a Well Plate. • Vial Type — Defines the Vial and Cap specifications. |

Temperature Controlled Drawer Option Pull-up Menu

Selecting the pull-up menu **Options** opens up the following tasks. See [Table 39](#).

Table 39. Option Pull-up Menu for Temperature Controlled Drawer (Sheet 1 of 2)

| Item | Description |
|----------------|---|
| Check Teaching | <p>Checks the teaching position of the module. This task serves as a quick check to determine if the X-, Y-, and Z-positions are defined correctly.</p> <p>In case a teaching point is off, return to the Menu Setup for readjustment of the teaching position. Please note that this action can be done under the Extended User Level but not under User Level.</p> |
| Teach module | <p>The positions of the X-, Y-, and Z-axes can be defined again, teaching.</p> |

Table 39. Option Pull-up Menu for Temperature Controlled Drawer (Sheet 2 of 2)

| Item | Description |
|------------------------------|--|
| Activate Standby Temperature | This task activates the newly-set Standby Temperature. |

When the Standby Temperature is changed, the newly-selected temperature is not immediately active. Use the pull-up menu **Options** and select **Activate Standby Temperature**. This second step activates the new Standby Temperature.

| Item | Description |
|----------------------------|--|
| New Rack | This task allows creation of a new Rack. |
| New Well Plate | This task allows copying of the present Well Plate |
| Delete Tray Type [Rack(#)] | This task allows deleting the present Tray Type. Example Rack 1. |

Another **Options** pull-up Menu is available when the list item Rack(#) is selected:

| Item | Description |
|---------------------------|--|
| Adjust Needle Penetration | <p>This task allows adjustment of the Needle Penetration Depths in the vial. Manually turn the needle as far down in the vial as required. The cut-out in the Tray Holder frame as well as in the Rack allows visual control of the needle tip.</p> <p>Note The value found is not stored automatically. This task allows for a check only. If the needle penetration depth should be changed, select the parameter Rack Type to enter the newly-established Needle Penetration value.</p> |

Assigning a Tray Type to the Slot

When the **Slot** does not yet have a Tray assigned to it, the corresponding field is empty.

Pressing **Enter** an empty page is bring up. From the **Options** pull-up menu, select the required Tray to assign to the empty Slot. It is advisable to define a specific name for the selected Tray. All Trays assigned to the Temperature Controlled Drawer are now selectable for this type of Tray Holder.

Signals

Note Synchronization signals are inputs that tell the TriPlus 100 Liquid Sampler system when to wait or to proceed with a sample-processing step. Output signals are sent from the system to external devices to indicate the status or completion of particular processing steps.

❖ **To set-up the synchronizations Signals from the TriPlus 100 Liquid Sampler system to an external device**

The synchronization signals have to be set step-by step.

1. The first step is assigning an **Input Signal** and an **Output Signal**. The next step is to establish what type of contact is required to receive or send a TTL signal. It could be TTL (Transistor-Transistor Logic), a relays contact, an **Opto-coupler**, or another type. Add the required parameters such as **Pulse Duration** and **Blocking Time**. This section provides informations for copying the default signals, and adding for example a second output signal if required. An output signal is required to send a start signal to the external device. Typically the Switch Out Signal1 (**SWOut1**) is used for this task.

A second output signal, named **Destination Aux**, can be used for cases where one command is sent to two different GC which must be started at the same time. A Y-shape synchronization cable is required for connecting the TriPlus 100 Liquid Sampler system to the two GC units. One signal used could be **SWOut1** and the second signal would be **SWOut2**.

The assigned signals must be matched with the pin allocation of the synchronization cable.

2. The second step is to synchronize the signal parameters with the device as a GC. This step is made in the section “[Input/Output Interface](#)” on [page 67](#).

The **Ready** signal from the GC is usually sent to the system, and a TTL-In signal is used to receive the **Ready** signal. Depending on the GC manufacturer settings, the signal is set to **active high** or **active low**. This synchronization is matched in the section **Input/Output Interface**.

3. The third step is to bundle the required Input and Output Signals for a specific chromatographic system, such as a GC System. This bundle can be configured once and tested in the combination of the system and the other device. This bundling is described in the section “[Chromatograph System](#)” on [page 66](#) as the last step in setting up signals.

Selecting the list item **Signals** opens up the following parameters. See [Figure 50](#).

Figure 50. Menu List Item Signals and List Items Input and Output Signals

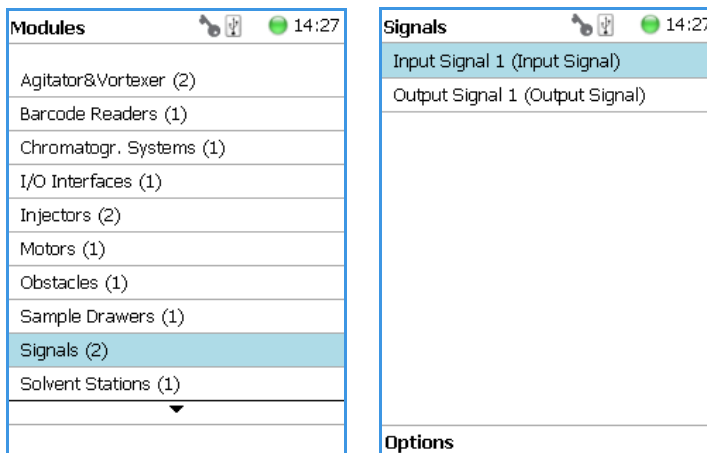

Press **Enter** to edit a parameter. See [Table 40](#) and [Table 41](#).

Table 40. Input Signal Parameters

| Items | Description |
|---------------|--|
| Input Signal | Selects the required Input Signal. Typically used for the Ready Signal (TTL-In). |
| Signal On | Indicates if the signal has been received. A crossed-out box means that a signal has been received. |
| Blocking Time | Used to program a time delay after receiving the signal (usually the Ready Signal from an external device). |
| Source | Selects the required Input Signal for synchronization with an external device. Usually a TTL-In contact is used to receive the Ready Signal from an external device. |

Table 41. Output Signal Parameters

| Item | Description |
|-----------------|---|
| Output Signal | Selects the required Output Signal. |
| Signal On | Indicates if the signal has been received. A crossed-out box means that a signal has been received. |
| Destination | Selects the required Output signal for the synchronization with an external device. Usually a switch out signal (SW Out) contact is used to send the Start Signal to an external device. |
| Destination Aux | Allows selecting a second, auxiliary Output Signal, which will be executed simultaneously as the signal Destination. |
| Pulse Duration | Selects the time how long the signal is sent. |

Signals Option Pull-up Menu

Selecting the pull-up menu **Options** opens up the following tasks. See [Table 42](#).

Table 42. Option Pull-up Menu for Signals

| Item | Description |
|----------------------|---|
| New Signal | A new Input or Output Signal can be created with this task. A dialog window opens allowing you to assign a unique name to the new signal. When finished, press New and the entire class with the corresponding parameters is copied over. Select the required contact, such as a TTL-In or a SW Out using the parameter Source . The signal name does not require to be in a consecutive order for example, Input Signal 2 , it can also be a specifically-named signal such as Inject or Start . Some cycles require a specifically-named signal. Check the cycle description for specific names. |
| Copy Input Signal | An Input Signal can be copied with this task. The task functions in a similar manner as described above with New Signal . |
| Copy Output Signal | Copies an Output Signal. The task functions in a similar manner as described above with New Signal . |
| Delete Input Signal | Deletes an Input Signal which is no longer required for the system configuration in combination with an external device. |
| Delete Output Signal | Deletes an Output Signal which is no longer required for the system configuration in combination with an external device. |
| Set Signal | Activates the selected signal for the time set with the parameter Duration . Since the Duration time is usually short, a status change in the parameter Signal ON is not visible. |
| Reset to Default | Resets the selected module parameters to default value. |

Solvent Stations

Selecting the list item **Solvent Stations** opens up the following parameters. See [Figure 51](#).

Figure 51. Menu Items for Solvent Stations and Menu Item Large Solvent Station

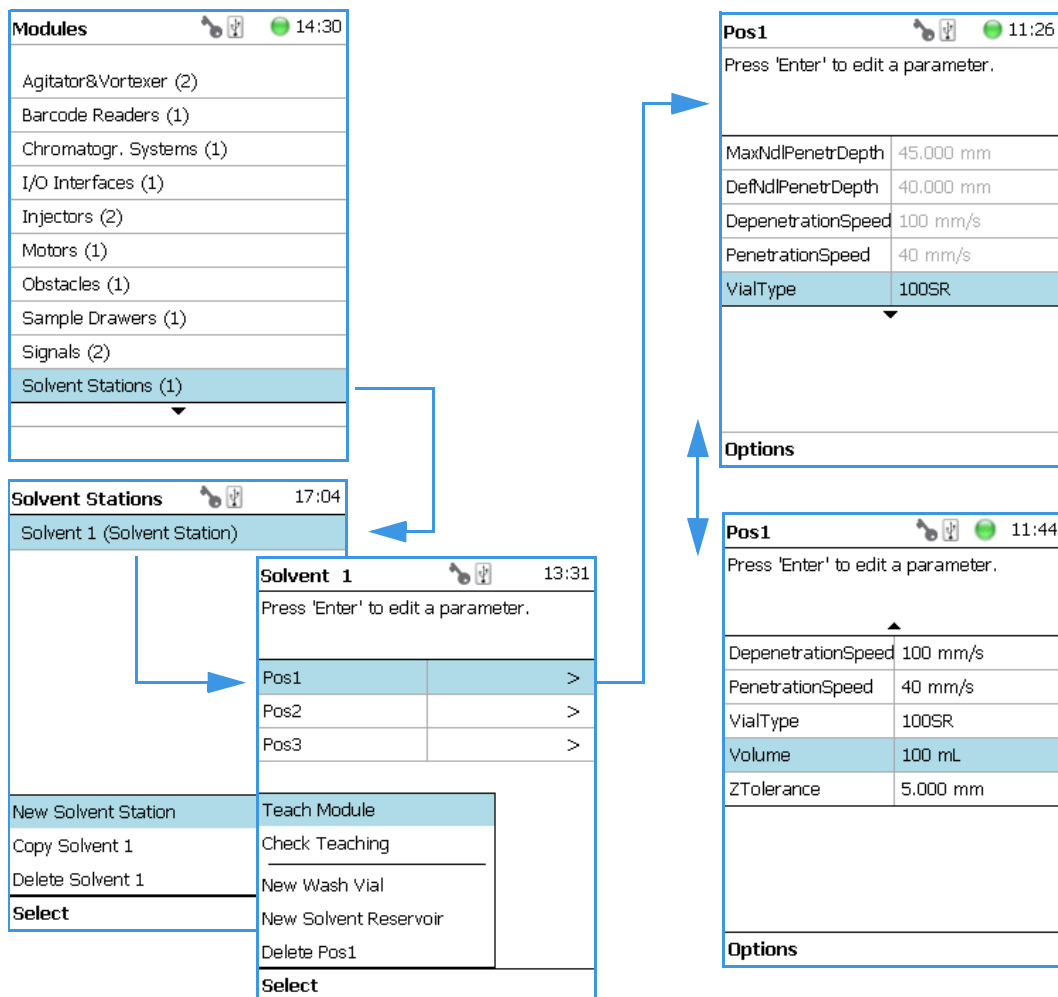

Pos1 = Large solvent reservoir bottle (100 mL volume in back position)
 Pos2 = Large solvent reservoir bottle (100 mL volume in middle position)
 Pos3 = Large solvent reservoir bottle (100 mL volume in front position)

Selecting one of the positions allows the operator to access following parameters. See [Table 43](#).

Table 43. Solvent Station Parameters

| Item | Description |
|----------------------------------|---|
| Max Needle Penetration Depth | The maximum allowed Needle Penetration can be defined as a safety measure so that you cannot destroy the needle tip by going too far down. The maximum needle penetration must not exceed the length of the syringe needle, considering the loss of approximately 12 mm due to the needle guide, and so on. For a typical needle length of 57 mm for the long needle, the maximum penetration depth must not exceed 45 mm. |
| Default Needle Penetration Depth | The default value of the syringe needle penetration depth in the reservoir vial is set by this parameter. |
| Depenetration Speed | Selects the required speed for pulling the syringe needle out of the reservoir vial. |
| Diameter | Defines the diameter of the solvent reservoir. |
| Height | Defines the height of the solvent reservoir |
| Penetration Speed | The syringe needle penetration speed is set by this value. It is recommended to use the default value first. Changing this parameter in one or the other direction might lead to needle bending. |
| Vial Type | Selects a predefined Vial Type. |
| Volume | Defines the volume of the reservoir container. |
| Z-Tolerance | A tolerance window to give a plus/minus range (expressed in mm) where the Head must expect an object. <ul style="list-style-type: none"> • If the value is set > 0, it indicates a relative detection mode, and the sensor from the Head needle guide is active. • If the value is set to 0, the Needle Guide Motor detection current is turned off and the syringe slider moves to an absolute value, the Z-axis position as specified by the object. |

Solvent Station Options Pull-up Menu

Selecting the pull-up menu **Options** opens up the following tasks. See [Table 43](#).

Solvent Station Options Parameters (Sheet 1 of 2)

| Item | Description |
|--------------------------|-------------------------------------|
| New Solvent Station | Creates a new Solvent Station. |
| Copy Solvent Station (1) | Copies the present Solvent Station. |

Solvent Station Options Parameters (Sheet 2 of 2)

| Item | Description |
|----------------------------|--|
| Delete Solvent Station (1) | Deletes the present Solvent Station. |
| Reset to Default | Resets the module parameters to default values. |
| Check Teaching | Checks the teaching position of the module. This task serves as a quick check to determine if the X-, Y-, and Z-positions are defined correctly. In case a teaching point is incorrect, return to the Menu Setup for readjustment of the teaching position. Please note that this action can be done under the Extended User Level but not under User Level . |
| Teach Module | Resets the selected module parameter to default value. |
| New Wash Vial | Defines a new Wash Vial. |
| New Reservoir Vial | Defines a new Reservoir Vial. |
| Delete Pos(1) | Deletes Position #1. |

Syringe Types

The Syringe Type section contains a list of known syringes and covers the syringe definition. Upon selecting the list item **Syringe Type**, the following parameters are available for modification. See [Figure 52](#).

Figure 52. Menu List Item Syringe Types and List Items Syringe Types

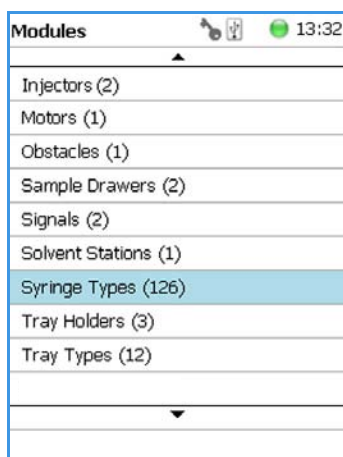

Press **Enter** to edit a parameter.

Selecting a syringe, for example a 10 µL Liquid Syringe, opens all the necessary parameters to define the syringe in geometry, and to define default values for an optimized use. See [Table 44](#).

Table 44. List of Syringe Types Parameters

| Item | Description |
|------------------------|--|
| Def Aspirate Acc | Specifies the default aspirate acceleration in $\mu\text{L}/\text{s}^2$. |
| Def Aspirate | Specifies the default aspirate flowrate in $\mu\text{L}/\text{s}$. |
| Def Aspirate Acc | Specifies the default aspirate acceleration in $\mu\text{L}/\text{s}^2$. |
| Def Aspirate Delay | Specifies the default aspirate delay time after the end of the aspiration. |
| Def Dispense Acc | Specifies the default dispense acceleration in $\mu\text{L}/\text{s}^2$. |
| Def Dispense | Specifies the default dispense flowrate in $\mu\text{L}/\text{s}$. |
| Def Dispense Delay | Specifies the default dispense delay after the end of the dispense. |
| Dispense Max | Specifies the maximum dispense flow rate in $\mu\text{L}/\text{s}$. |
| Def Fill Strokes Asp | Specifies the default fill strokes aspiration flowrate in $\mu\text{L}/\text{s}$. |
| Def Fill Strokes Count | Specifies the default number of syringe plunger strokes from the same vial, to have a homogeneous phase between the headspace gas in the vial and the sample in the syringe. |
| Def Fill Strokes Disp | Specifies the default fill strokes dispense flowrate in $\mu\text{L}/\text{s}$. |
| Def Fill Strokes Vol | Specifies the default fill strokes volume in μL . |
| Def Pen Vel | Specifies the default penetration velocity in mm/s . |
| Max Dispense | Specifies the maximum dispense flowrate in $\mu\text{L}/\text{s}$. |
| Max Fill Strokes Asp | Specifies the maximum fill strokes aspirate flowrate in $\mu\text{L}/\text{s}$. |
| Max Fill Strokes Disp | Specifies the maximum fill strokes dispense flowrate in $\mu\text{L}/\text{s}$. |
| Max Pen Depth | Specifies the maximum penetration depth in mm . |
| Max Pen Force | Specifies the maximum penetration force in N . |
| Max Pen Vel | Specifies the maximum penetration speed in mm/s . |
| Needle Gauge | Specifies the syringe suppliers specific. |
| Needle Inner Dia | Specifies the internal diameter of the syringe needle in mm . |
| Needle Length | Specifies the length of the syringe needle in mm . |
| Needle Out Dia | Specifies the external diameter of the syringe needle in mm . |
| Plunger Tip | Specifies the syringe suppliers specific. |
| Point Style | Specifies the syringe suppliers specific. |
| Scale Length | Specifies the length of the scale in mm |
| Syringe Volume | Specifies the volume of the syringe in μL . |

Tray Holders

Tray Holders are passive modules. These modules are described by their geometric design parameters, but there is no control whatsoever through the TriPlus 100 Liquid Sampler system. A Tray Holder can be a Liquid Cooled Tray (using a circulation bath for heating/cooling), or a Tray Holder without any temperature control. Selecting the list item **Tray Holder** opens up the following parameters. See [Figure 53](#).

Figure 53. Menu Item 'Tray Holder and List Items for Tray Holders

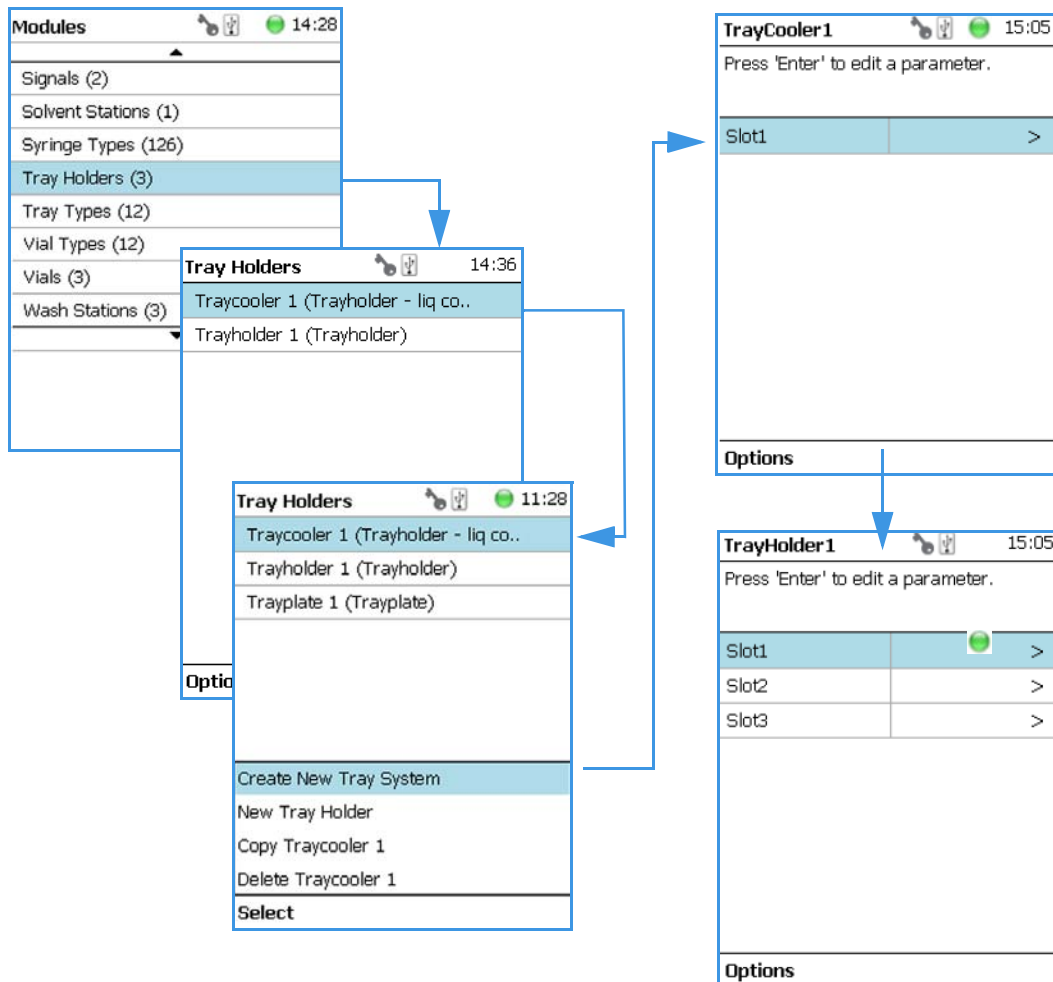

Press **Enter** to edit a parameter.

Selecting the list item **Slot** opens the dialog window for **Tray** (Rack), which contains the parameters **Tray Type** and **Vial Type**. If no Tray is assigned yet, use the button **New** to assign a Tray to a particular Slot. The dialog for naming a Tray can be started by pressing the **Enter** button. See the examples. See [Figure 54](#).

Figure 54. Tray Type and Vial Type Selections to Assign to Tray

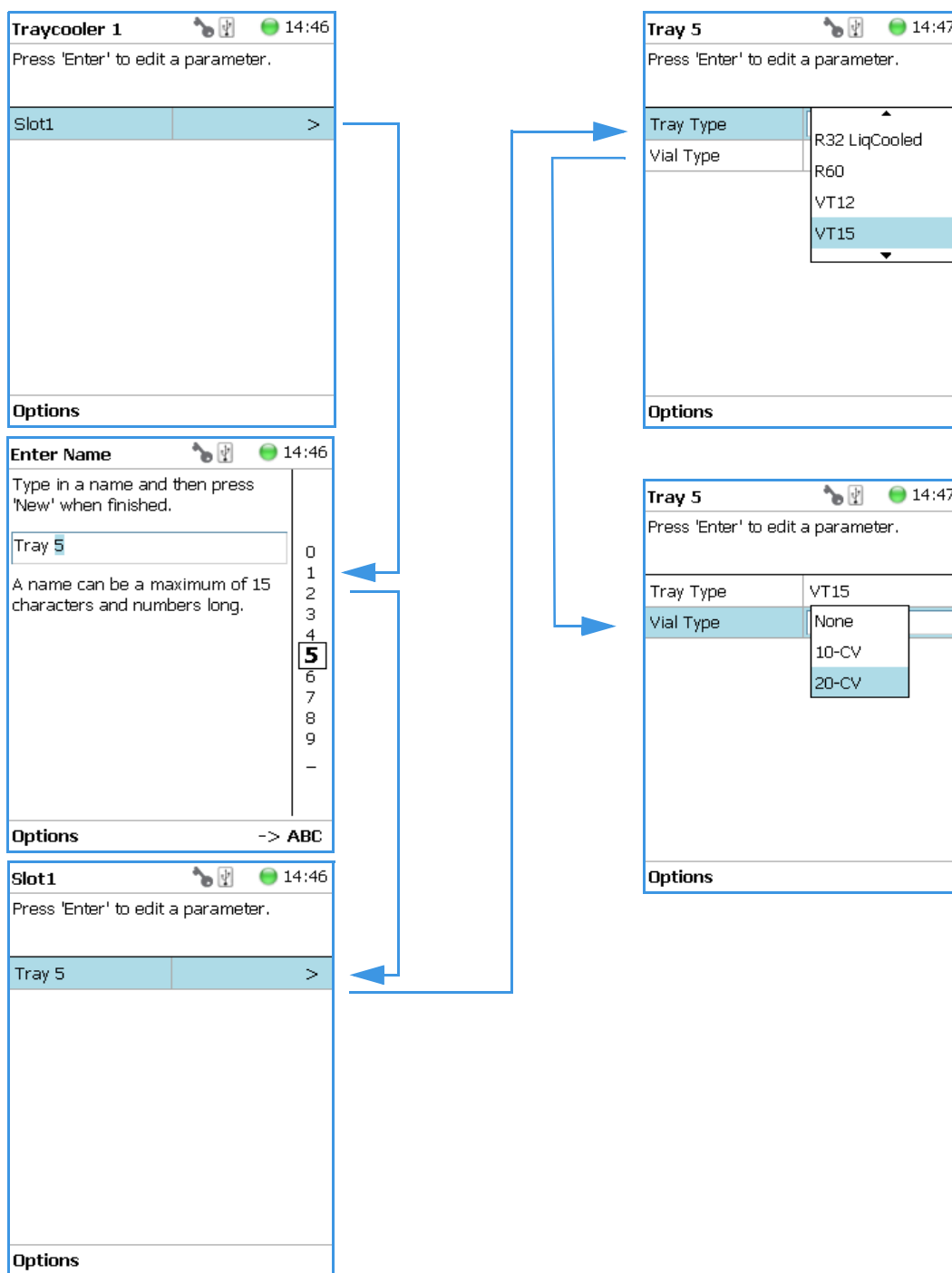

- **Slot(#)** — Selects the required Slot number to assign a Tray Type and Vial Type.
- **Cap Type** — Describes the Cap Type. Read-only. The definition is made in the class Vial type.
- **Tray(#)** — Selects the required Tray number to assign the Tray Type and Vial Type

- **Tray Type** — A list with all predefined Tray Types opens up for selection.
- **Vial Type** — A list with all predefined Vial Types opens up for selection.
- **Well Plate** — Select the required Well Plate number to assign the Well Plate Type.
- **Well Plate Type** — A list with all predefined Well Plate Types opens up for selection.

Note A passive Tray Holder module can adapt Trays made for different vial sizes. When the different Trays are used, consider the various vial heights, and ensure that the Stack Drawer Magnet, connected to the lower needle guide, does not catch at front row of vials from behind the Tray.

Tray Holder Options Pull-up Menu

Selecting the pull-up menu **Options** opens up the following tasks. See [Table 45](#).

Table 45. Tray Holder Option pull-up Menu Parameters

| Item | Description |
|------------------------|---|
| Create New Tray System | Allows creation of a new Tray System. The wizard guides you through the definition of tray holder, Tray Slot, Trays, Tray Types, Vial Type, and Number of Trays required for the new Tray system. See “Create New Tray System Item” on page 148. |
| New Tray Holder | Creates of a new Tray Holder. |
| Copy Tray Holder | Copies the present Tray Holder. |
| Delete Tray Holder | Deletes the present Tray Holder. |

Another Option pull-up Menu is available when the list item **Tray(#)** is selected. See [Table 46](#).

Table 46. Tray Holder Option pull-up Menu Parameters When Tray(#) is Selected (Sheet 1 of 2)

| Item | Description |
|---------------------------|--|
| Adjust Needle Penetration | Allows adjusting of the Needle Penetration Depths in the vial. Manually turn the needle as far down in the vial as required. The cut-out in the Tray Holder frame as well as in the Tray allows visual control of the needle tip. Note The value found is not stored automatically. This task allows a check only. If the needle penetration must be changed, select the Tray Type to enter the new established Needle Penetration value. |

Table 46. Tray Holder Option pull-up Menu Parameters When Tray(#) is Selected (Sheet 2 of 2)

| Item | Description |
|----------------|---|
| Teach Module | The positions of the X-, Y-, and Z-axes can be defined again, teaching. |
| Check Teaching | Checks the teaching position of the module. This task serves as a quick check to determine if the X-, Y-, and Z-positions are defined correctly. In case a teaching point is incorrect, return to the Menu Setup for readjustment of the teaching position. Please note that this action can be done under the Extended User Level but not under User Level . |

Tray Types

A Tray Type contains all the information about the geometry of the Tray. Parameters such as how many sample vials are in a column and in a row, and the distance from vial to vial, are all summarized in this class for each Tray Type.

Selecting the list item **Tray Types** opens up the following parameters. See [Figure 55](#).

Figure 55. Menu Item 'Tray Types and Menu List Items Tray Types

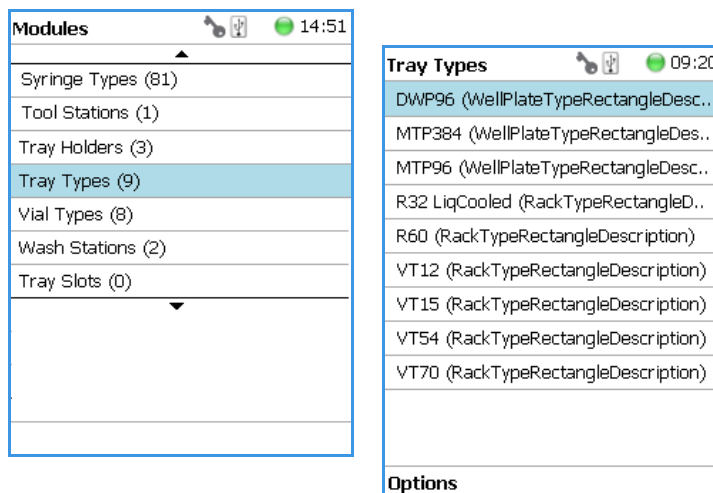

The individual parameters are identical for each Tray Type. The main difference depends on the primary differentiation of a **Tray Type** or **Plate Type**. In

a Tray Type vials are inserted, the combined height of a Tray and the height of the vial above the upper surface of the Tray yields to the total height of the Tray Module.

A Plate has no vial inserted and the total height of the Tray corresponds with the height of the Well Plate.

The second main difference is the order of sample treatment.

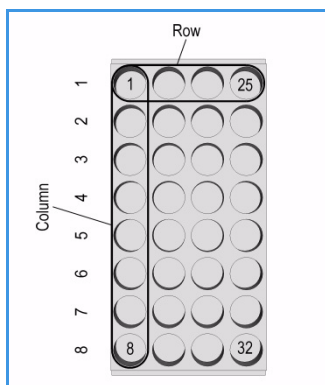

Tray type R32 LiqCooled

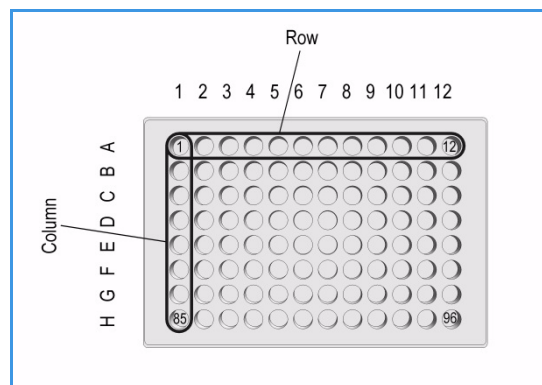

Well Plate type MTP96

Press **Enter** to edit a parameter. See [Table 47](#).

Table 47. Tray Type Parameters (Sheet 1 of 3)

| Item | Description |
|----------------------|--|
| 1st Sample Offset X | Offset distance from Tray Zero Point to first position in X-axis direction. Unit: mm. |
| 1st Sample Offset Y | Offset distance from Tray Zero Point to first position in Y-axis direction. Unit: mm. |
| 1st Sample Offset Z | Offset distance from Tray Zero Point to first position in Z-axis direction. Unit: mm. (This parameter is currently not used with released Tray Types. Value = 0) |
| Alt Sample Offset X | Offset from Tray Zero Point to first sample position of staggered row/column in direction X-axis. Unit: μm . |
| Alt Sample Offset Y | Offset from Tray Zero Point to first sample position of staggered row/column in direction Y-axis. Unit: μm . |
| Alt Sample Z | Offset from Tray Zero Point to first sample position of staggered row/column in direction Z-axis. Unit: μm . (This parameter is currently not used with released Tray Types. Value = 0) |
| Cavity Depth | Defines the total depth of the cavity. Unit: mm. |
| Cavity Diameter | Defines the diameter of the cavity. Unit: mm. |
| Columns | Number of columns. |
| Indexing Orientation | Defines the order of sampling either in Column Direction or in Row direction . <i>Examples:</i> Tray VT54: Row Direction. |
| Length X | Total length of the Tray in X-axis direction, outer frame of Tray is considered. Unit: mm. |

Table 47. Tray Type Parameters (Sheet 2 of 3)

| Item | Description |
|------------------------|---|
| Length Y | Total length of the Tray in Y-axis direction, outer frame of Tray is considered. Unit: mm. |
| Length Z | Total length of the Tray in Z-axis direction, outer frame of Tray is considered. Unit: mm. |
| Penetration Vial Index | Specifies the position in the Tray where the cut-out for needle penetration adjustment is located. |
| Rows | Number of rows. |
| Slot Offset X | Distance from Tray Holder Zero Point to Slot in X-axis direction. Used for Trays which are larger than the footprint of the Slot, (Oversize). |
| Slot Offset Y | Distance from Tray Holder Zero Point to Slot in Y-axis direction. Used for Trays which are larger than the footprint of the Slot, (Oversize). |
| Slot Offset Z | Distance from Tray Holder Zero Point to Slot in Z-axis direction. Used for Trays which are larger than the footprint of the Slot, (Oversize). |
| Slot Span | Number of the Tray installed on the Tray Holder. Examples: Tray 60: Slot Span 1. Tray 54: Slot Span 3. Note A Tray Type with a SlotSpan >1 has to be positioned in Slot1. The Rack does 'span' from Slot1 to Slot2 to Slot3. |
| Tot. Column Length X | Defines the total length of the Column (X-axis). Distance from center to center of cavity is measured. Unit: mm. |
| Tot. Row Length Y | Defines the total length of the Row (Y-axis). Distance from center to center of cavity is measured. Unit: mm. |
| Uses Adapter | Select this parameter when an Adapter is used to compensate for vial height. The adapter installed plus the vial height must not exceed the total height of a 20 mL vial. Example: 10 mL vial plus corresponding adapter must be equal to the height of a 20 mL vial. |

Table 47. Tray Type Parameters (Sheet 3 of 3)

| Item | Description |
|---|---|
| Z Tolerance | <p>A tolerance window to give a plus/minus range (expressed in mm) where the Head must expect an object.</p> <p>If the value of this item is > 0, indicates a relative detection mode, and the sensor from the Head needle guide is active.</p> <p>If the value of this item is set to 0, the Needle Guide Motor detection current is turned off, and the syringe slider moves to an absolute value. The Z-axis position as specified by the object.</p> <p>The ZTolerance is calculated in combination with a Rack from the Vial top. The Rack plate top surface is not used as reference.</p> <p>The ZTolerance is calculated in combination with a Well Plate (MTP) from the plate top surface.</p> |
| DefNdlPenetrDepth <i>(Parameter used for MTP only)</i> | <p>Defines the default value for the syringe needle penetration depth in the well of the Micro Titer Plate (MTP). Unit: mm.</p> |
| Depenetration Speed <i>(Parameter used for MTP only)</i> | <p>Defines the speed of the syringe needle de-penetration from the well of the Micro Titer Plate (MTP). Unit: mm/s.</p> |
| Sealing Foil <i>(Parameter used for MTP only)</i> | <p>Setting the mark to Has Foil indicates that the plate is sealed with a foil. The Foil Piercing Tool will be applied.</p> |
| MaxVolume <i>(Parameter used for MTP only)</i> | <p>Defines the maximum volume of the well of a Micro Titer Plate (MTP). Unit: mL.</p> |
| Penetration Speed <i>(Parameter used for MTP only)</i> | <p>Defines the speed of the syringe needle penetration from the well of the Micro Titer Plate (MTP). Unit: mm/s.</p> |

The tray type parameters are described in the following [Table 48](#).

Table 48. Tray Type Parameters (Sheet 1 of 5)

| Tray Type Parameter | Illustration |
|---|--|
| <p>Rows — Number of Rows</p> <p>Columns — Number of Columns</p> <p>Definition of Row and Column</p> <p>Example: Regular order of vials.</p> | <p>Figure 56. Tray type R32 Liq.Cooled</p>  |
| <p>Rows — Number of Rows</p> <p>Columns — Number of Columns</p> <p>Definition of Row and Column</p> <p>Example: Regular order of vials.</p> | <p>Figure 57. Tray type VT54</p>  |
| <p>Rows — Number of Rows</p> <p>Columns — Number of Columns</p> <p>Definition of Row and Column</p> <p>Example: Regular order of wells.</p> | <p>Figure 58. Tray type MPP 96</p>  |

Table 48. Tray Type Parameters (Sheet 2 of 5)

| Tray Type Parameter | Illustration |
|------------------------------------|---------------------------------|
| Rows — Number of Rows | Figure 59. Tray type R12 |
| Columns — Number of Columns | |
| Definition of Row and Column | |
| Example: Staggered order of vials. | |

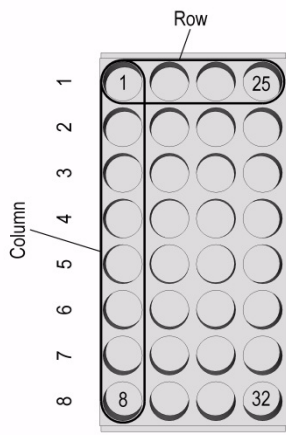
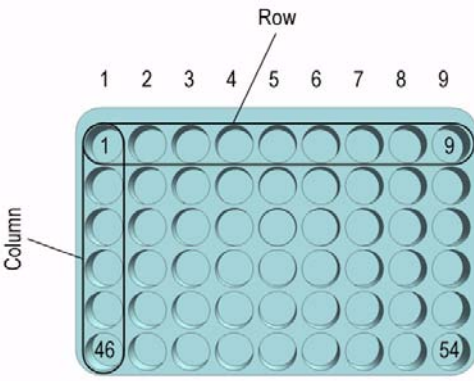
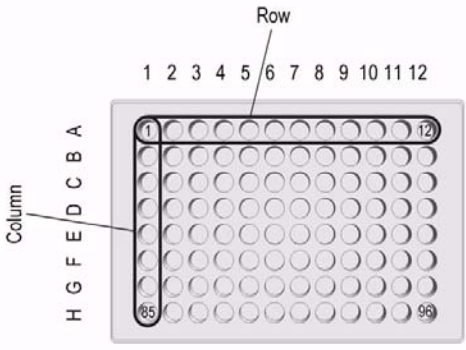
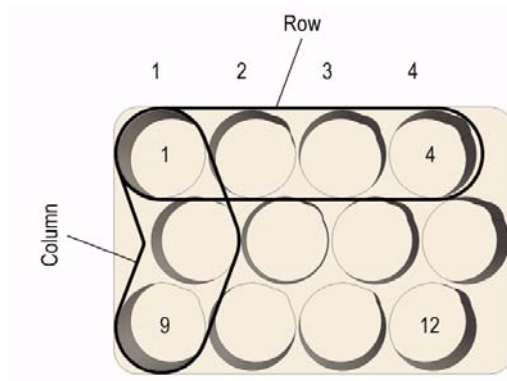

Indexing Orientation — DirectionX

Figure 60. Indexing orientation

Row Direction
Column Direction)

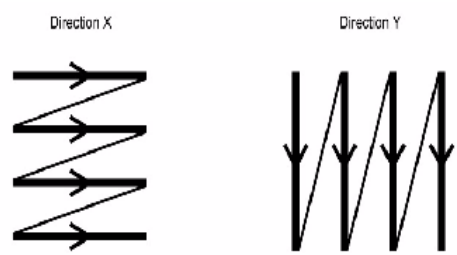

FirstSampleOffsetX

Figure 61. Tray type R32 Liq.Cooled

FirstSampleOffsetY
(FirstSampleOffsetZ)

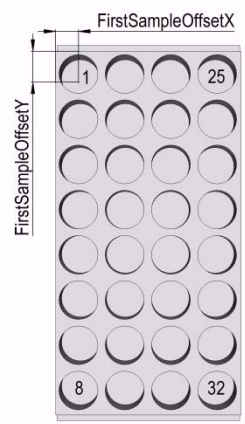

Table 48. Tray Type Parameters (Sheet 3 of 5)

| Tray Type Parameter | Illustration |
|--|--|
| FirstSampleOffsetX | Figure 62. Tray type VT54 |
| FirstSampleOffsetY (FirstSampleOffsetZ) |  |
| AlternateSampleX | Figure 63. Tray type R12 |
| AlternateSampleY (AlternateSampleZ) |  |
| LengthX | Figure 64. Tray type R32 Liq.Cooled |
| LengthY |  |
| LengthZ | |
| TotalColumnLengthX | |
| TotalRowLengthY | |

Table 48. Tray Type Parameters (Sheet 4 of 5)

| Tray Type Parameter | Illustration |
|----------------------|---|
| LengthX | <p>Figure 65. Tray type VT54</p>  |
| LengthY | |
| LengthZ | |
| TotalColumnLengthX | |
| TotalRowLengthY | |
| CavityDepth | <p>Figure 66. Tray type MTP96</p>  |
| CavityDiameter | |
| PenetrationVialIndex | <p>Figure 67. Tray type VT54</p>  |
| ZTolerance | <p>Figure 68. Tray type MTP96</p>  |

Table 48. Tray Type Parameters (Sheet 5 of 5)

| Tray Type Parameter | Illustration |
|---|--|
| SlotSpan | Figure 69. Tray Holder with Tray Type VT54 inserted |
| Example: SlotSpan = 1 |  |
| SlotOffsetX | |
| SlotOffsetY | |
| Note that the value has a negative sign if the Tray is oversize, which means larger than the Tray Holder. | |
| SlotOffsetZ | |
| Note that the value has a negative sign if the Tray is not inserted in the slot, support for Tray is higher up. | |
| UsesAdapter | Figure 70. Agitator |

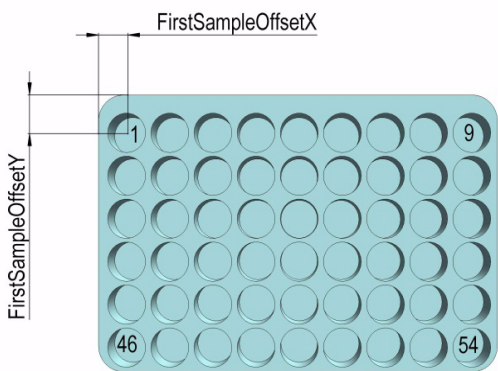
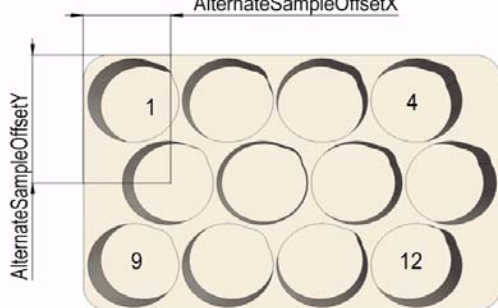
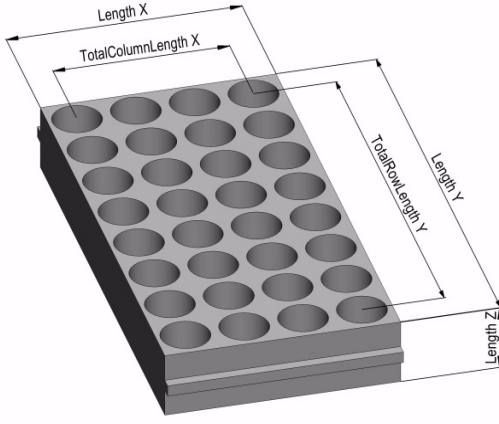

Tray Types Options Pull-up Menu

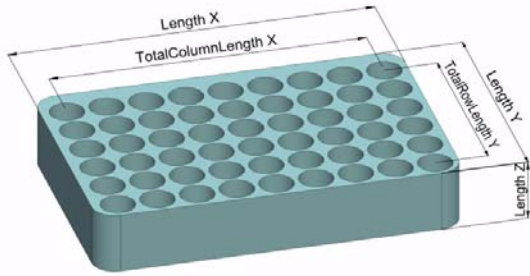
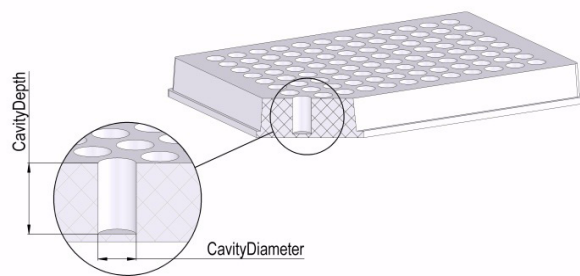
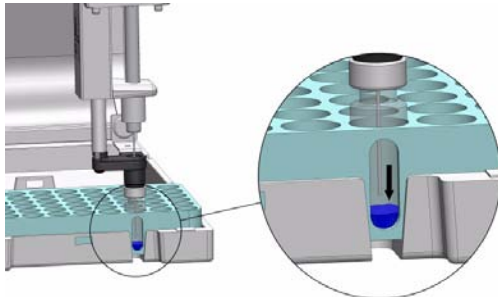
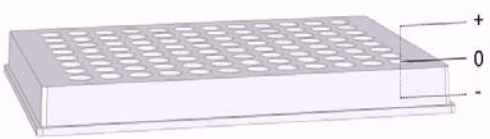
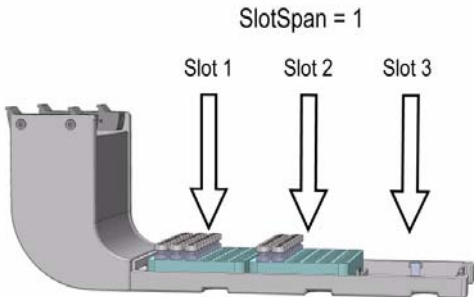
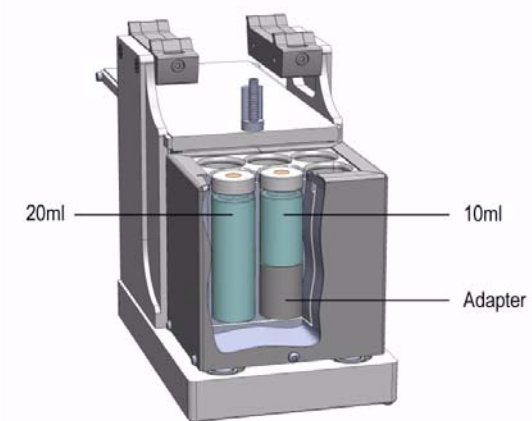
Selecting the pull-up menu **Options** opens up the following tasks. See [Table 49](#).

Table 49. Tray Types Options Pull-up Menu

| Item | Description |
|------------------|---|
| New Tray Type | Creates a new Tray Type. |
| Copy VT54 | Copies the present Tray Type (for example VT54). |
| Delete VT54 | Deletes the present Tray Type (for example VT54). |
| Reset to Default | Resets the selected Tray Holder parameter to default value. |

Note There are no other pull-up menu items available. Currently it is not possible to create custom Tray Types.

Trays

The term Trays is a generic term. A Tray can be a Tray or a Well-plate.

A Tray is prepared to accept vials, a well-plate can be typically a Deep well-plate or a Micro Titer-plate. The software has a structure which interlinks the classes **Vial Type**, **Tray Type** (or Well Type) with the Tray. To create a new Tray these classes have to be prepared in the order **Vial Type** and **Tray Type**. The allocated types are then ready for selection in the class Trays.

Selecting the list item **Tray Types** opens up the following parameters. See [Figure 71](#).

Figure 71. Menu Item Trays Menu List Item Trays

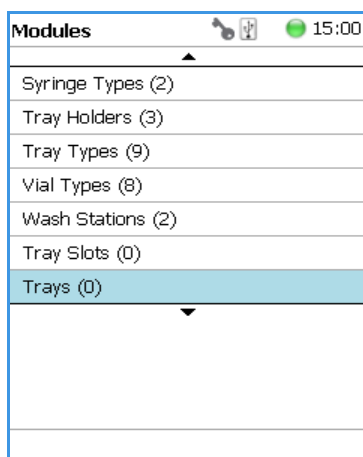

Press **Enter** to edit a parameter. See [Table 50](#).

Table 50. Tray Type and Vial Type Parameters

| Item | Description |
|-----------|--|
| Cap Type | Read-only parameter. Definition is made in the class Vial Type. |
| Tray Type | A Tray Type is assigned the specified Tray. |
| Vial Type | A Vial Type is assigned to the specified Tray and selected Tray Type |

Trays Options Pull-up Menu

Selecting the pull-up menu **Options** opens up the following tasks. See [Table 51](#).

Table 51. Tray Option Pull-up Menu Parameters

| Item | Description |
|-------------|----------------------------|
| New Tray | Creates a new Tray Holder. |
| Copy Tray | Copies the present Tray. |
| Delete Tray | Deletes a present Tray. |

In the case no Tray is available, the command **New Tray** is available with the **Menu Button Option**.

Follow the dialog with the known possibilities to assign a name as shown in [Figure 72](#).

Figure 72. Menu Button New Tray and Defining Name for New Tray

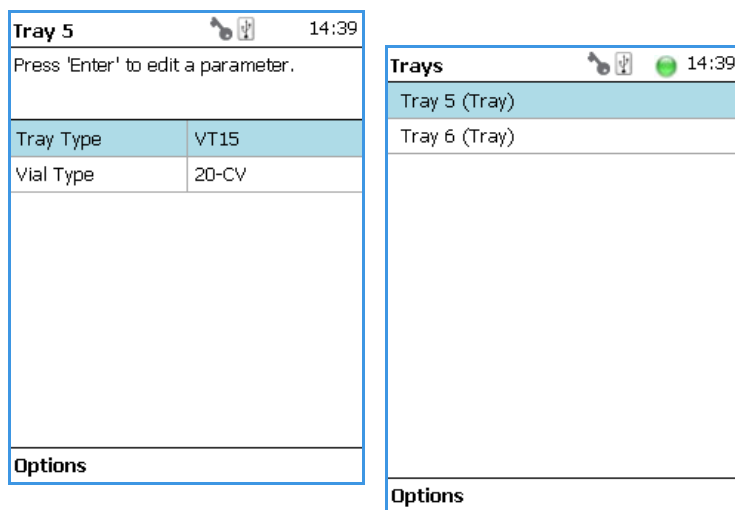

Another pull-up menu is available from the menu list items **Tray Type** and **Vial Type**. Selecting the item **Adjust Needle Penetration** allows checking the needle penetration in the vial. The position of cut-out in the Tray is specified in the Tray Type, therefore is the position known. Starting this task, moves the Head to the defined vial position where it waits for the manual adjustments. See [Figure 73](#), illustrating the cut-out in the Tray.

Figure 73. Adjust Needle Penetration Into the Vial

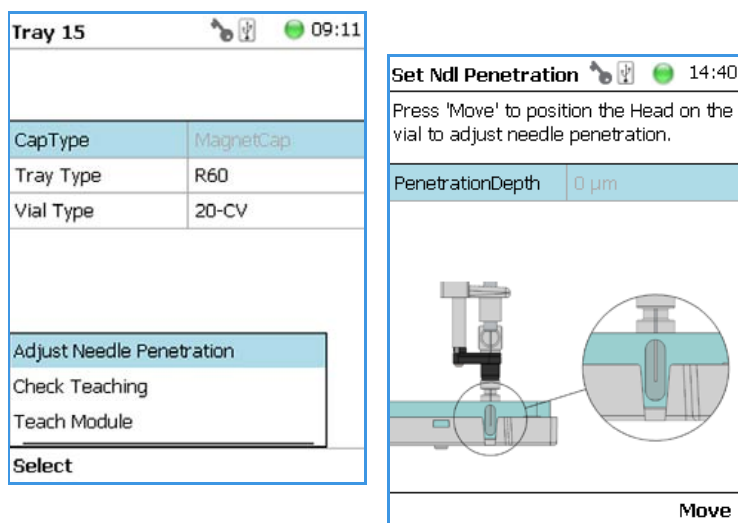

Trays Options Menu Parameters are detailed in [Table 52](#).

Table 52. Trays Options Menu Parameters

| Item | Description |
|---------------------------|---|
| Adjust Needle Penetration | Adjusts the Needle Penetration Depths in the vial. Manually turn the needle as far down in the vial as required. The cut-out in the Tray Holder frame as well as in the Tray allows visual control of the needle tip. Note The value found is not stored automatically. This task allows a check only. If the needle penetration must be changed, select the Tray Type to enter the newly established Needle Penetration value. |
| Teach Module | The positions of the X-, Y-, and Z-axes can be defined again, for teaching. |
| Check Teaching | Checks the teaching position of the module. This task serves as a quick check to determine if the X-, Y-, and Z-positions are defined correctly. In case a teaching point is incorrect, return to the Menu Setup for readjustment of the teaching position. Please note that this action can be done under the Extended User Level but not under User Level . |

Vial Types

The Vial Type describes the geometry of the vials used and adds parameters such as syringe needle penetration, search distance, or Z-Tolerance. The Vial Type is a group of parameters which can be linked to a Tray, Wash Station, or any other module which requires a vial. Selecting the list item **Vial Types** opens up the following parameters. See [Figure 74](#).

Figure 74. Menu Items Vial Types and List Items for Vial Type

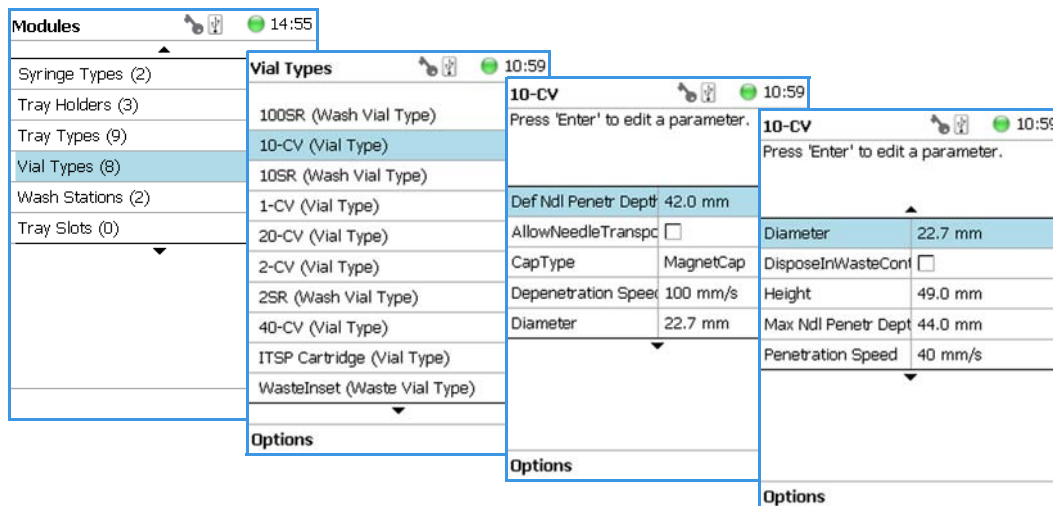

Vial Types Parameters are detailed in [Table 53](#).

Table 53. Vial Types Parameters (Sheet 1 of 2)

| Item | Description |
|--|---|
| Default Needle Penetration Depth | The default value of the syringe needle penetration depth in the reservoir vial is set by this parameter. |
| Allow Needle Transport <i>Available for Vial Type only.</i> | Sets the transport to Needle Transport . In order to allow another transport as the common Magnetic Transport the syringe needle is inserted in the vial septum. If the weight of the vial is not too high, the vial sticks to the needle. All parameter as used for the magnetic transport (such as stripping of) are not functional. |
| Cap Type <i>This parameter has to correspond with the Tool parameter "Needle Guide Type".</i> | The type of cap used for the vial can be defined. The following options are available: <ul style="list-style-type: none"> • No Cap — Mainly used for Well-plates • Magnet Cap — A magnetic cap is used to transport a vial, typically from a Tray to the Agitator. • Non Magnetic Cap — For applications which do not require the sample vials to be transported. |

Table 53. Vial Types Parameters (Sheet 2 of 2)

| Item | Description |
|----------------------|--|
| Depenetration Speed | Defines the speed to retrieve the syringe needle from the vial. |
| Diameter | Defines the diameter of the reservoir container. |
| Height | Defines the height of the reservoir container. |
| Max Ndl Penetr Depth | <p>The maximum allowed Needle Penetration can be defined as a safety measure so that you cannot destroy the needle tip by going too far down. The maximum needle penetration must not exceed the length of the syringe needle, considering the loss of approximately 12 mm due to the needle guide.</p> <p>For a typical needle length of 57 mm for the long needle, the maximum penetration depth must not exceed 45 mm.</p> |
| Penetration Speed | The syringe needle penetration speed is set by this parameter. It is recommended to use the default value first. Changing this parameter in either direction might lead to needle bending. |
| Strip Distance | When a magnetic cap is used, the distance to move the Head to the side (in the Y-direction) to wipe off the vial can be defined. Measured in millimeters. |
| Volume | This parameter defines the volume of the vial. |
| Z-Tolerance | <p>A tolerance window to give a plus/minus range (expressed in mm) where the Head must expect an object.</p> <p>If the value of this item is > 0, this indicates a relative detection mode, and the sensor from the Head needle guide is active.</p> <p>If the value of this item is set to 0, the sensor of the needle guide is turned off, and the syringe slider moves to an absolute value, Z-axis position as specified in the object.</p> |

Vial Type Options Pull-up Menu

Selecting the pull-up menu **Options** opens up the following tasks. See [Table 54](#).

Table 54. Vial Type Options Pull-up Menu (Sheet 1 of 2)

| Item | Description |
|----------------|-------------------------------|
| New Vial Type | Creates a new Vial Type. |
| Copy Vial Type | Copies the present Vial Type. |

Table 54. Vial Type Options Pull-up Menu (Sheet 2 of 2)

| Item | Description |
|------------------|--|
| Delete Vial Type | Deletes a present Vial Type. |
| Reset to Default | Resets the selected module parameter to the default value. |

Vials

In this class of **Vials**, dedicated vials can be added to the system configuration. The use of the **Vial** can be specified according to the following categories

- Wash Vial
- Waste Vial
- Reservoir

The use of these **Vials** is in assigning an extra, custom specific vial, for any use, such as providing a dedicated vial for a reagent, internal standard or a dilution vial. When the application requires a second Waste Vial or an extra Wash Vial, then this class of **Vial** could be used to define the non-standard vial.

The three categories **Wash Vial**, **Waste Vial**, and **Solvent Reservoir** contain the same available parameters under the **User Access Level**.

Selecting the list item **Vial** opens up the following parameters:

Figure 75. Menu List Vials and Menu List Items for Vials

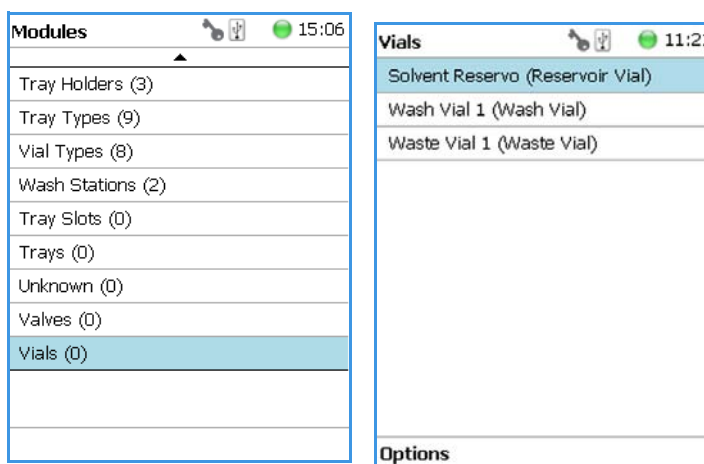

In the case when there is no **Vial** (Solvent Reservoir, Wash Vial, or Waste Vial) available, the command **New Vial** is available with the **Menu Button Option**. Follow the dialog with the known possibilities to assign a name as shown in [Figure 76](#).

Figure 76. Menu Button New Vial, Selection of Vial Types, and Defining Name for New Vial

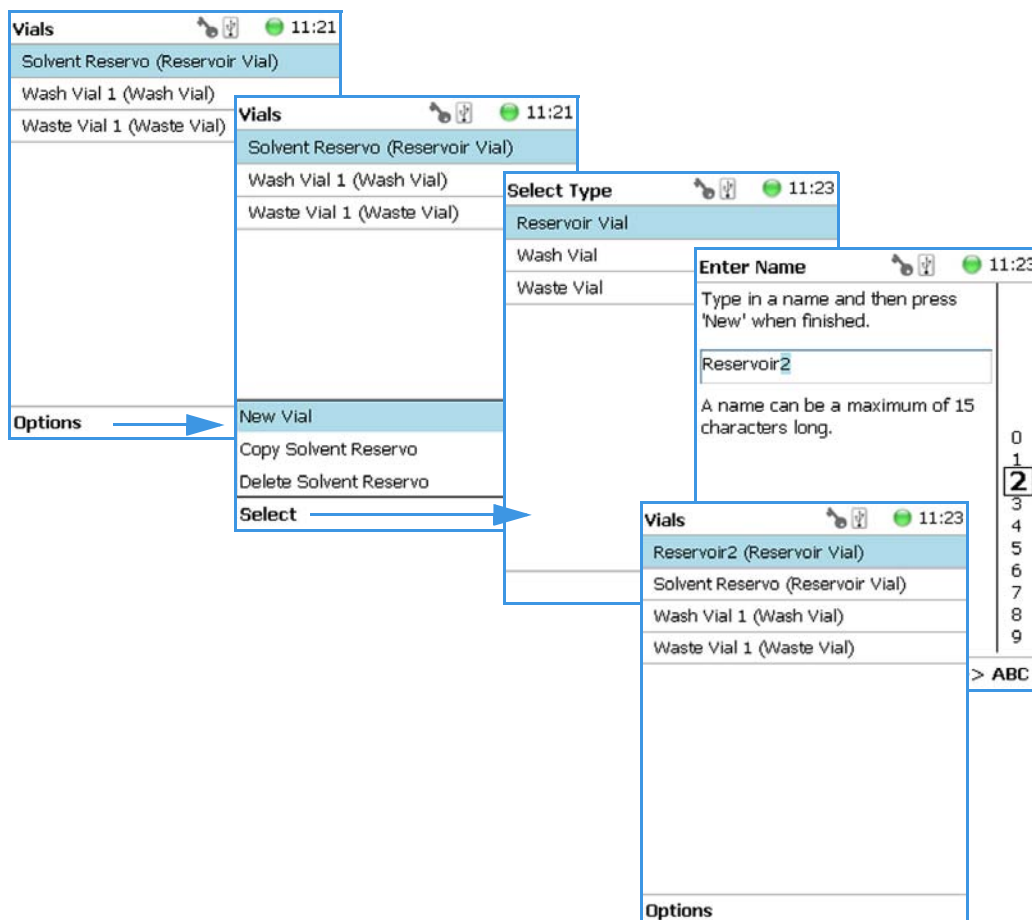

The parameters available for the **Vial Type** reservoir are slightly different from the parameters for the Wash Vial and Waste Vial. See the examples in [Figure 77](#) and [Figure 78](#), and the description in [Table 55](#).

Figure 77. Menu List Item Reservoir Parameters for Vial Type Reservoir

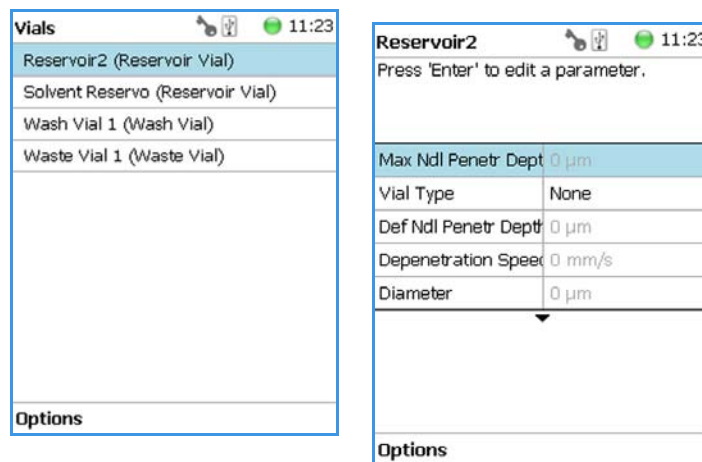

Figure 78. Parameters for Vial Types Wash or Waste Parameters for Vial Types Wash or Waste

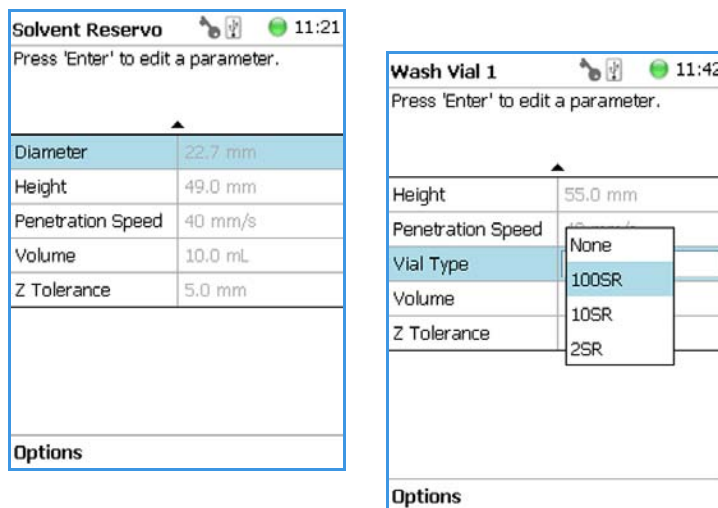

Table 55. Vial Parameters (Sheet 1 of 2)

| Item | Description |
|------------------------|---|
| Max Penetration Depths | The maximum allowed Needle Penetration can be defined as a safety measure so that you cannot destroy the needle tip by going too far down. The maximum needle penetration must not exceed the length of the syringe needle, considering the loss of approximately 12 mm due to the needle guide, and other factors. For a typical needle length of 57 mm for the long needle, the maximum penetration depth must not exceed 45 mm. |
| Def Nedl Penetr Depth | The default value of the syringe needle penetration depth in the reservoir vial is determined by this parameter. |
| Depenetration Speed | This parameter allows you to select the required speed for pulling the syringe needle out of the reservoir vial. |
| Diameter | Specific for Waste Vial. Defines the diameter of the reservoir container. |
| Height | Specific for Waste Vial. Defines the height of the reservoir container. |
| Penetration Speed | The syringe needle penetration speed is set by this value. It is recommended to use the default value first. Changing this parameter in one or the other direction might lead to needle bending. |

Table 55. Vial Parameters (Sheet 2 of 2)

| Item | Description |
|-------------|---|
| Vial Type | <p>A list with all predefined Vial Types opens up for selection.</p> <p>Special cases for Waste Vial:</p> <ul style="list-style-type: none"> • None — It is selectable, however if selected in combination with a Wash Module is an error message (Pending Message) propagated. Incompatible Type. • Waste Port — Used for the Fast Wash and Large Wash Module. • Waste Vial — Used for Standard Wash Module. • Waste Inset — This type is used for Standard Wash Module with inserted Waste Line Adapter. |
| Volume | <p>Specific for Wash and Waste Vial. Defines the volume of the reservoir container.</p> |
| Z-Tolerance | <p>Specific for Wash and Waste Vial. A tolerance window to give a plus/minus range (expressed in mm) where the Head must expect an object.</p> <ul style="list-style-type: none"> • If the value of this item is > 0, indicates a relative detection mode, and the sensor from the Head needle guide is active. • If the value of this item is set to 0 the sensor of the needle guide is turned off and the syringe slider moves to an absolute value, the Z-axis position as specified by the object. |

Vial Option Pull-up Menu

Selecting the pull-up menu **Options** opens up the following tasks. See [Table 56](#).

Table 56. Options Vial Type Pull-up Menu (Sheet 1 of 2)

| Item | Description |
|-------------|---------------------------|
| New Vial | Creates of a new Vial. |
| Copy Vial | Copies the present Vial. |
| Delete Vial | Deletes the present Vial. |

Table 56. Options Vial Type Pull-up Menu (Sheet 2 of 2)

| Item | Description |
|----------------|--|
| Check Teaching | Checks the teaching position of the module. This task serves as a quick check to determine if the X-, Y-, and Z-positions are defined correctly. In case a teaching point is off, return to the Menu Setup for readjustment of the teaching position. Please note that this action can be done under the Extended User Level but not under User Level . |
| Teach Module | The positions of the X-, Y-, and Z-axes can be defined again, (teaching). |

Wash Stations

Selecting the list item **Wash Stations** opens up the following parameters:

Figure 79. Menu Item Wash Stations Menu and List Items Wash Modules

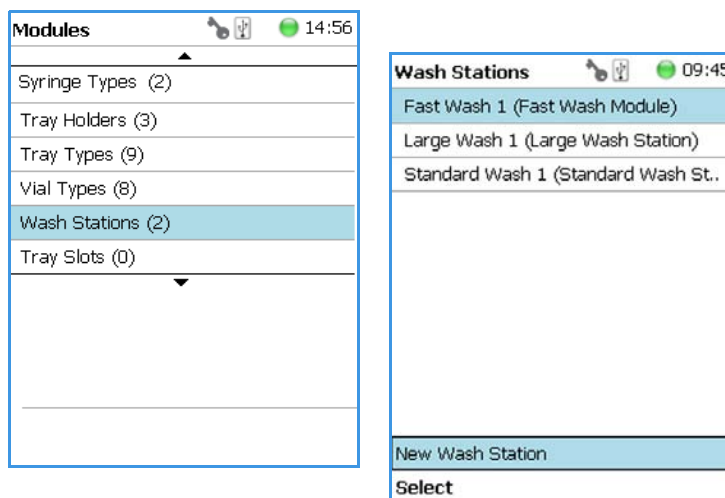

Press **Enter** to edit a parameter.

Select the required menu list item to access the parameters. The wash stations differ in number of positions and Wash Vial size.

- The **Standard Wash Station** accepts 10 mL vials.
- The **Large Volume Wash Station** contains two 100 mL vials, and a Waste position with a drainage tubing.
- The **Fast Wash Station** contains active pumps to deliver two different wash solvents

The available menu list parameters are identically for the **Standard** and **Large** Wash Stations, asides from the number of positions. See [Table 57](#).

Parameters for Standard and Large Wash Station

Table 57 lists the parameters for the Standard and Large Wash Stations.

Table 57. Parameters for Standard and Large Volume Wash Stations (Sheet 1 of 2)

| Item | Description |
|----------------------|--|
| Pos1 to Pos4 | Positions 1 and 2 are available for the Large Wash Station. Positions 1 to 4 are available for the Standard Wash Module. Each Position can be defined by using the next parameters. |
| Waste | Defines the Waste position. |
| Max Ndl Penetr Depth | The maximum allowed Needle Penetration can be defined as a safety measure so that the you cannot destroy the needle tip by going too far down. The maximum needle penetration must not exceed the length of the syringe needle, considering the loss of approximately 12 mm due to needle guide, and so on. For a typical needle length of 57 mm for the long needle, the maximum penetration depth must not exceed 45 mm. |
| Def Ndl Penetr Depth | Sets the default value of the syringe needle penetration depth in the reservoir vial. |
| Depenetration Speed | Allows selecting the required speed for pulling the syringe needle out of the reservoir vial. |
| Penetration Speed | The syringe needle penetration speed is set by this parameter. It is recommended to use the default value first. Changing this parameter in one or the other direction might lead to needle bending. |
| Vial Type | <p>Defines the Vial Type of the reservoir container in Positions or the corresponding Waste Type in Waste Position.</p> <ul style="list-style-type: none"> • Selection for Wash Positions: Vial Types None, 2SR, 10SR, or 100SR. • Selection for Waste Position: None <p>Note If None is selected, an error (Pending Message) will be propagated.</p> <p>Waste Port (Large Wash);</p> <p>Waste Vial (Standard Wash).</p> <p>Waste Inset (Fast Wash Module; not implemented yet).</p> |
| Volume | Defines the volume of the reservoir vial. |

Table 57. Parameters for Standard and Large Volume Wash Stations (Sheet 2 of 2)

| Item | Description |
|---|---|
| Z-Tolerance | <p>A tolerance window to give a plus/minus range (expressed in mm) where the Head must expect an object.</p> <p>If the value of this item is > 0, this indicates a relative detection mode, and the sensor from the Head needle guide is active.</p> <p>If the value of this item is set to 0 the Needle Guide Motor detection current is turned off, and the syringe slider moves to an absolute value, Z-axis position as specified in the object.</p> |
| Diameter | Specific for Waste Vial. Defines the diameter of the reservoir container. |
| Height | Specific for Waste Vial. Defines the height of the reservoir container. |
| Is Detectable | Specific for Waste Vial. |
| <i>Visible for Waste Position only.</i> | Differentiates if the Waste position is a Vial, which is detectable, or if it is a nipple with a connected waste tubing. |

Parameters for Fast Wash Station

Table 58 lists the parameters for the Fast Wash Station.

Table 58. Parameters for Fast Wash Stations (Sheet 1 of 3)

| Item | Description |
|------------------|---|
| Wash 1 to Wash 2 | Wash positions 1 and 2 can be assigned to Fast Wash Station. |
| Waste | Defines the Waste position. |
| Max Flow Rate | Sets the upper limit of flow rate for the selected Wash Position. |
| Post Rinse Liner | <p>Activates the solvent pump to rinse the wash liner of the selected Wash Position. Number of rinse cycles is selectable after the syringe needle has been removed from the Wash Station.</p> <p>Note Without the syringe needle inserted in the liner, the solvent flow is unrestricted. Expect a higher solvent consumption.</p> |

Table 58. Parameters for Fast Wash Stations (Sheet 2 of 3)

| Item | Description |
|-----------------------|--|
| Pre Rinse Liner | <p>Activates the solvent pump to rinse the wash liner of the selected Wash Position. Number of rinse cycles is selectable before the syringe needle has been inserted into the Wash Station.</p> <p>Note Without the syringe needle inserted in the liner, the solvent flow is unrestricted. Expect a higher solvent consumption.</p> |
| Def Ndl Penetr Depth | <p>Sets the default value of the syringe needle penetration depth in the reservoir vial.</p> <p>The default values are:</p> <ul style="list-style-type: none"> • 25 mm in Wash position • 20 mm in Waste position |
| Depenetration Speed | <p>Selects the required speed for pulling the syringe needle out of the reservoir vial.</p> <p>The default values are:</p> <ul style="list-style-type: none"> • 100 mm/s in Wash position • 100 mm/s in Waste position |
| Max Penetration Depth | <p>The maximum allowed Needle Penetration can be defined as a safety measure so that the you cannot destroy the needle tip by going too far down. The maximum needle penetration must not exceed the length of the syringe needle, considering the loss of approximately 12 mm due to needle guide, and so on. For a typical needle length of 57 mm for the long needle, the maximum penetration depth must not exceed 45 mm.</p> <p>The default values are:</p> <ul style="list-style-type: none"> • 78 mm in Wash position • 60 mm in Waste position |
| Penetration Speed | <p>The syringe needle penetration speed is set by this parameter. It is recommended to use the default value first. Changing this parameter in one or the other direction might lead to needle bending.</p> <p>The default values are:</p> <ul style="list-style-type: none"> • 40 mm/s in Wash position • 40 mm/s in Waste position |

Table 58. Parameters for Fast Wash Stations (Sheet 3 of 3)

| Item | Description |
|-------------|--|
| Vial Type | <p>None: This task is selectable, however if selected in combination with a Wash Module is an error message (Pending Message) propagated. Incompatible Type.</p> <p>WastePort: This type is used for the Large Wash Module.</p> <p>WasteVial: This type is used for Standard Wash Module.</p> <p>WasteInset: This type is used for the Fast Wash Module. (Not implemented yet)</p> |
| Volume | Specific for Wash and Waste Vial. Defines the volume of the reservoir vial. |
| Z-Tolerance | <p>A tolerance window to give a plus/minus range (expressed in mm) where the Head must expect an object.</p> <p>If the value of this item is > 0, this indicates a relative detection mode, and the sensor from the Head needle guide is active.</p> <p>If the value of this item is set to 0, the Needle Guide Motor detection current is turned off, and the syringe slider moves to an absolute value, Z-axis position as specified in the object.</p> |
| Diameter | Specific for Waste Vial. Defines the diameter of the reservoir container. The default value is 20.0 mm |
| Height | Specific for Waste Vial. Defines the height of the reservoir container. The default value is 80.0 mm |

Wash Stations Option Pull-up Menu

Selecting the pull-up menu **Options** opens up the following tasks. See [Table 59](#) for Standard and Large Volume Wash Stations, and [Table 60](#) for Fast Wash Station.

Table 59. Standard and Large Volume Wash Option Parameters (Sheet 1 of 2)

| Item | Description |
|----------------|--|
| Check Teaching | <p>Checks the teaching position of the module.</p> <p>This task serves as a quick check to determine if the X-, Y-, and Z-positions are defined correctly.</p> <p>In case a teaching point is incorrect, return to the Menu Setup for readjustment of the teaching position. Please note that this action can be done under the Extended User Level but not under User Level.</p> |

Table 59. Standard and Large Volume Wash Option Parameters (Sheet 2 of 2)

| Item | Description |
|---------------------|--|
| Teach Module | The positions of the X-, Y-, and Z-axes can be defined again (teaching). |
| New Wash Station | Creates of a new Wash Station. |
| Copy Wash Station | Copies of the present Wash Station. |
| Delete Wash Station | Deletes of the present. Wash Station. |

Table 60. Fast Wash Option Parameters

| Item | Description |
|------------------|--|
| Teach Module | The positions of the X-, Y-, and Z-axes can be defined again (teaching). |
| Reset to Default | Resets the selected station parameter to default value. |
| Check Teaching | Checks the teaching position of the module. This task serves as a quick check to determine if the X-, Y-, and Z-positions are defined correctly. In case a teaching point is incorrect, return to the Menu Setup for readjustment of the teaching position. Please note that this action can be done under the Extended User Level but not under User Level . |
| New Wash Station | Creates of a new Wash Station. |
| Prime Wash Liner | Primes the tubing of the selected Wash Position. |
| Duration | Sets the time required for priming. |

Tray Slots

This menu List Item will be implemented in future. See [Figure 80](#).

Figure 80. Menu Item Tray Slots

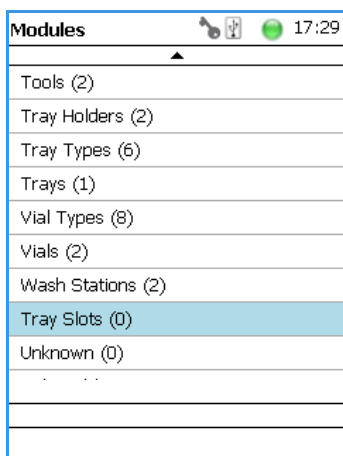

The image shows a screenshot of a software interface titled 'Modules'. The interface has a header bar with a key icon, a refresh icon, a green status indicator, and the time '17:29'. Below the header is a list of menu items, each with a count in parentheses. The 'Tray Slots (0)' item is highlighted with a light blue background. The list includes: Tools (2), Tray Holders (2), Tray Types (6), Trays (1), Vial Types (8), Vials (2), Wash Stations (2), Tray Slots (0), and Unknown (0). There are also three empty rows at the bottom of the list.

| Modules |
|-------------------|
| Tools (2) |
| Tray Holders (2) |
| Tray Types (6) |
| Trays (1) |
| Vial Types (8) |
| Vials (2) |
| Wash Stations (2) |
| Tray Slots (0) |
| Unknown (0) |
| |
| |
| |

Unknown

This menu List Item will be implemented in future.

Setup Menu Item - Set Date and Time

Visible in **Extended User** access level only.

1. Select in the **Option** pull-up menu the list item Set Date and Time. See [Figure 81](#) and [Table 61](#).

Figure 81. Set Date and Time

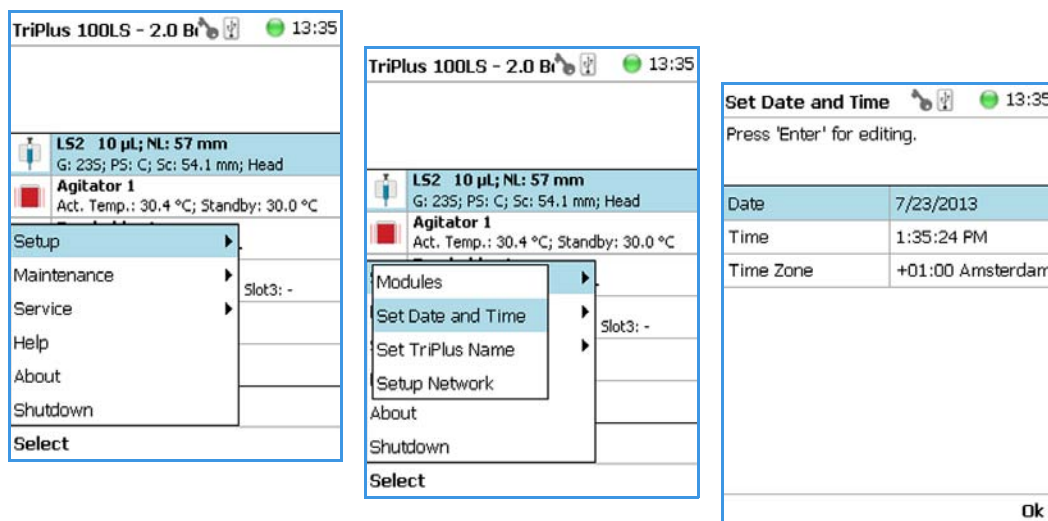

Table 61. Date and Time Format

| Item | Description |
|-------------------|--|
| Set Date and Time | Date: format yyyy-mm-dd |
| | Time: format hh:mm:ss |
| | Time Zone: Greenwich Mean Time (GMT) plus or minus the hour deviation from Greenwich standard time. |



3 Setup Menu Item

Setup Menu Item - Set TriPlus 100 Liquid Sampler Name

Setup Menu Item - Set TriPlus 100 Liquid Sampler Name

Visible in **Extended User** access level only.

1. Select from the **Option** pull-up menu the list item **Set TriPlus 100 Liquid Sampler Name**. See [Figure 82](#).

Figure 82. Set TriPlus 100 Liquid Sampler System Name

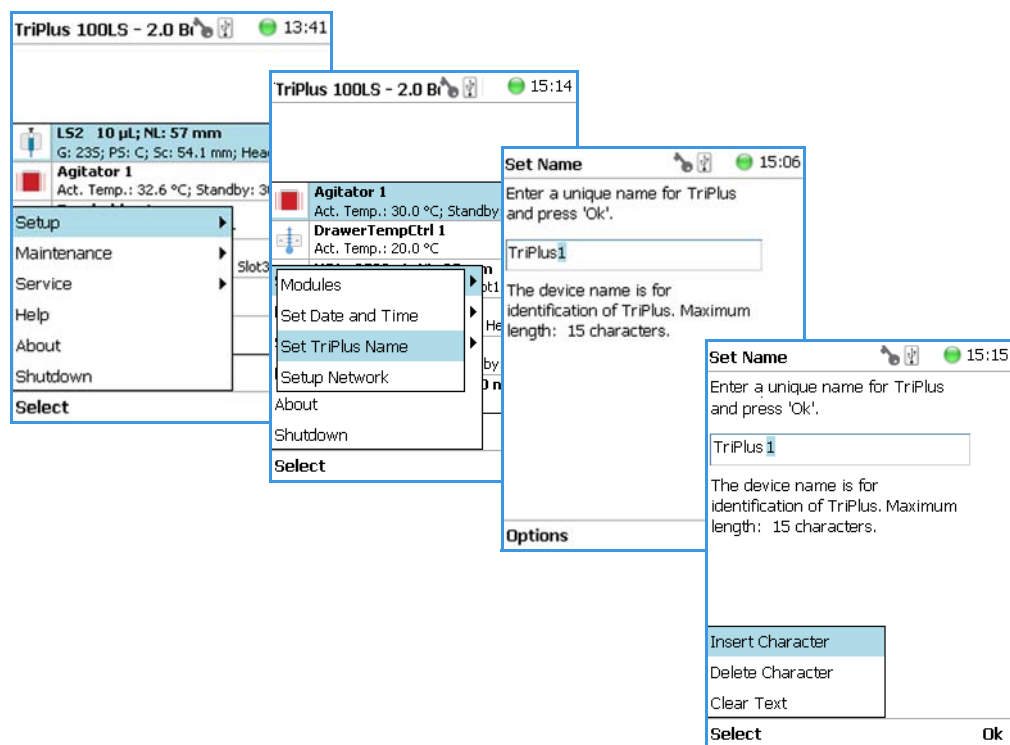

2. Press **Enter** to receive the alphabetical selection of characters or press the **Default Action** button to change from capital to lower case characters or to numbers. The name has to start with an alphabetical character.
3. Set a unique name for the TriPlus 100 Liquid Sampler system. This name will be stored and can be used for identification of the system.
4. Press **Option** to receive the list item **Insert** or **Delete Character** or **Clear Text**.
5. Press **Ok** when finished.

Setup Menu Item - Setup Network

Visible in **Extended User** access level only.

In order to select the required network setup according to your laboratory setting, the following possibilities are available:

- Direct connection
The TriPlus 100 Liquid Sampler system is directly connected to the computer via the LAN cable. There is no corporate network or router connection.
 - IP Address TriPlus 100 Liquid Sampler system: 192.168.99.230
 - IP Address computer: 192.168.99.210
 - Subnet Mask: 255.255.255.0
 - Default Gateway: not required, leave the field empty (if an address is entered, it will not be used).
 - Corporate Network with DHCP Protocol Ask the network administrator to verify and integrate the setup within the corporate network. Select the DHCP Protocol, the network will assign an IP Address and a Subnet Mask to the TriPlus 100 Liquid Sampler system.
 - Corporate Network with Fixed IP Address Ask the network administrator to provide the **IP Address**, **Subnet Mask** and **Default Gateway** to configure the TriPlus 100 Liquid Sampler system within the corporate network.
1. Select from the **Option** pull-up menu the list item **Setup Network**. See [Figure 83](#) and [Table 62](#).

Figure 83. Setup Network

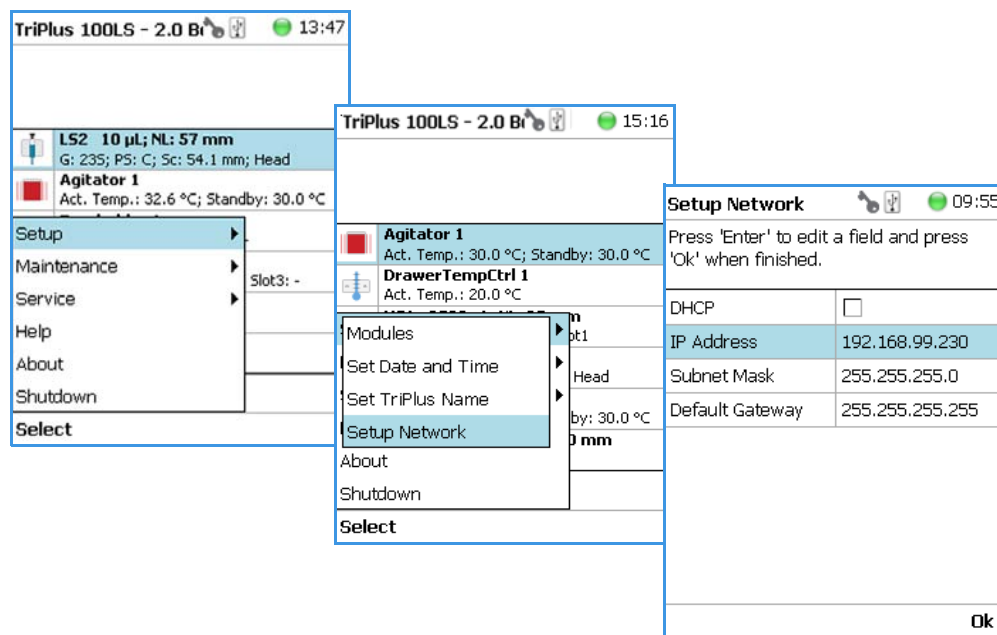

2. Select either the mode **DHCP** or enter a unique fixed IP Address.
3. Press **Ok** when finished.

Table 62. Setup Network Parameters

| Items | Description |
|-----------------|---|
| Setup Network | Defines the Network communication parameters. |
| DHCP | Dynamic Host Configuration Protocol. If activated, an IP Address is dynamically sought throughout the provided network. It is advisable not to use the DHCP mode but to use a fixed IP Address. |
| IP Address | The IP Address is a fixed system address. The IP Address is often provided by the network administrator. Default Address for the TriPlus 100 Liquid Sampler system: 192.168.99.230. |
| Subnet Mask | The Subnet Mask is used for network configuration; it must be provided by the network administrator. Default Subnet mask: 255.255.255.0. |
| Default Gateway | The Gateway is used if independent networks must communicate interactively. Communication within the network is provided by a hub or switch, defined as Gateway . Default Gateway is 192.168.99.1. |

Note For more information see Setting up the Network Interface in the *TriPlus 100 Liquid Sampler Hardware Manual*.

Maintenance Menu Items

This chapter describes the options of the **Maintenance Menu** operated either with the Virtual Handheld Controller, or directly using the installed Handheld Controller.

Contents

- [Maintenance Menu](#)
- [Check Teaching Module](#)
- [Check Configuration](#)
- [Reset Configuration](#)
- [Create Diagnostic Backup](#)
- [Create Configuration Backup](#)
- [Copy Backup](#)
- [Restore Backup](#)

Maintenance Menu

The Maintenance function is available from the **Options** pull-up menu. See [Figure 84](#).

Figure 84. Maintenance

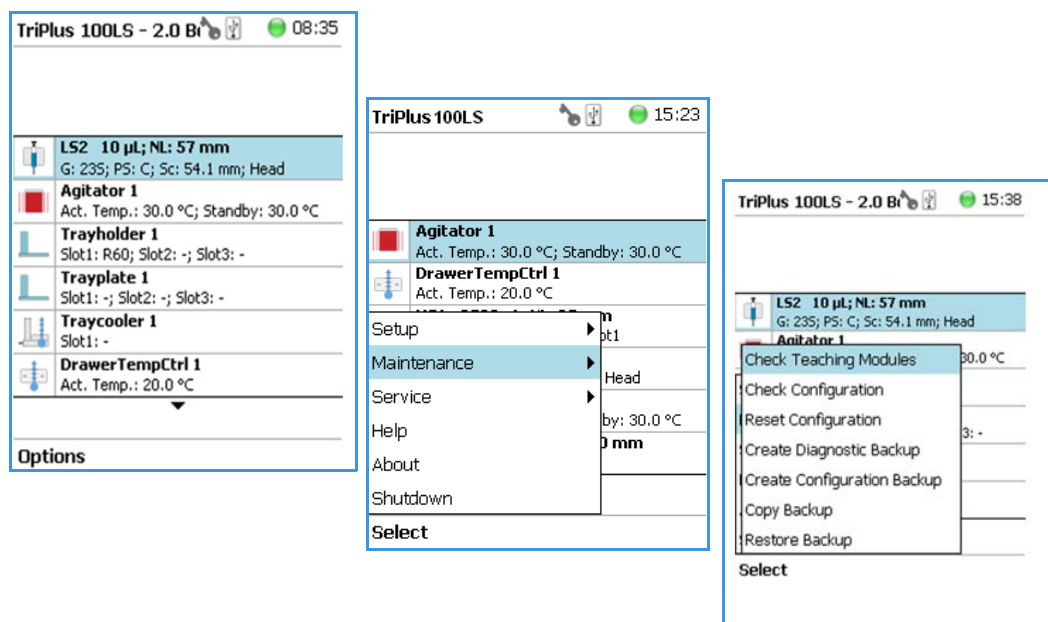

1. Press the **Options** button to open the pull-up menu, and select **Maintenance**.
2. Select the folder **Maintenance** for accessing the list items.

Note In order to perform any action under the section Maintenance, it is a prerequisite that the system motors have already been calibrated.
To perform the motor calibration select **Setup | Modules | Motors** or **Service | Installation | Calibrate Motors**.

Refer to the following items:

- “[Check Teaching Module](#)” on page 121
- “[Check Configuration](#)” on page 121
- “[Reset Configuration](#)” on page 122
- “[Create Diagnostic Backup](#)” on page 122
- “[Create Configuration Backup](#)” on page 123
- “[Copy Backup](#)” on page 124
- “[Restore Backup](#)” on page 124

Check Teaching Module

Selecting **Check Teaching** modules the TriPlus 100 Liquid Sampler Head moves from one module to the next, in the order listed in the table **modules**. The unit waits at the programmed teaching point for visual inspection; press the button **Next** to continue. If a teaching point is incorrect return to the Menu **Setup** for readjusting the teaching position of the module involved. The automated check of the teaching position of all the modules is stopped by pressing the **Back** button.

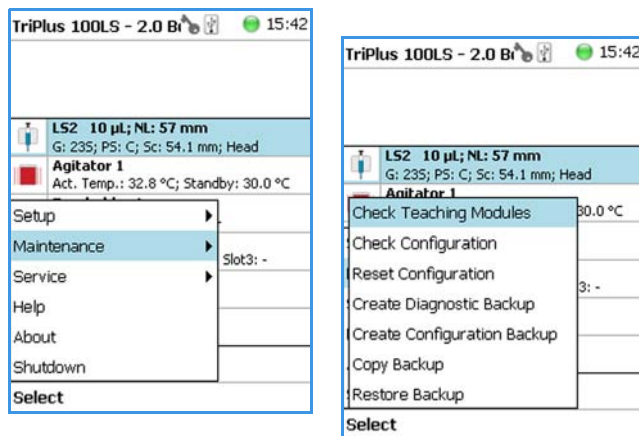

Check Configuration

Selecting **Check Configuration** provides the possibility to check the entire system configuration for any mismatches. **Pending Messages** or **Service Issues** which have been clicked away can be retrieved again.

The software checks the entire configuration for any hidden problems. The message symbol (Envelope) in the Status Line indicates that one or more mismatches have been detected.

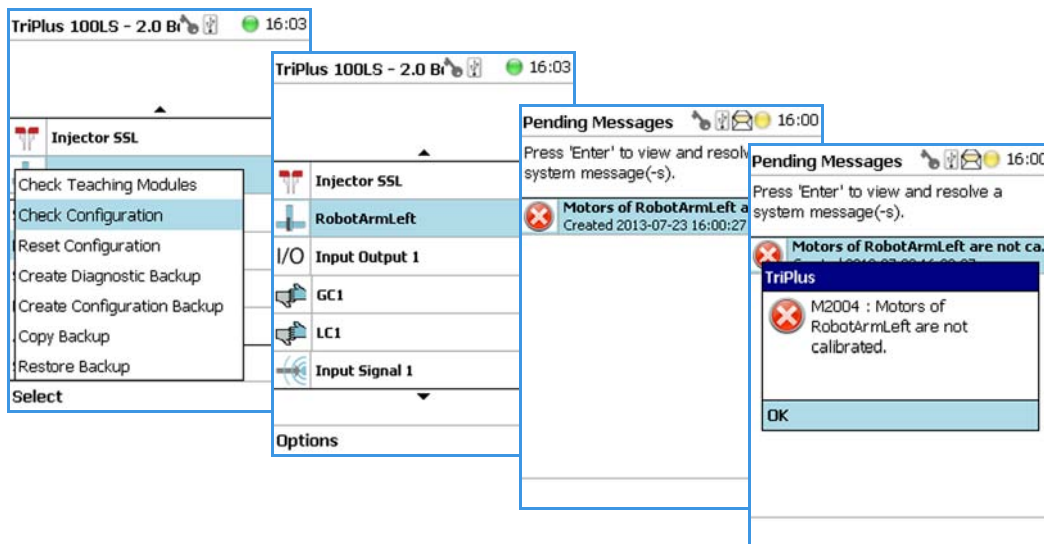

4 Maintenance Menu Items

Reset Configuration

Select from the pull-up menu the **Pending Messages** or **Service Issues**. Please note that the messages can be opened and viewed in the **Extended User** access level only.

Reset Configuration

By selecting **Reset Configuration** the Firmware (Application) resets the configuration to a standard application package. You must follow all the steps in the Installation Wizard again.

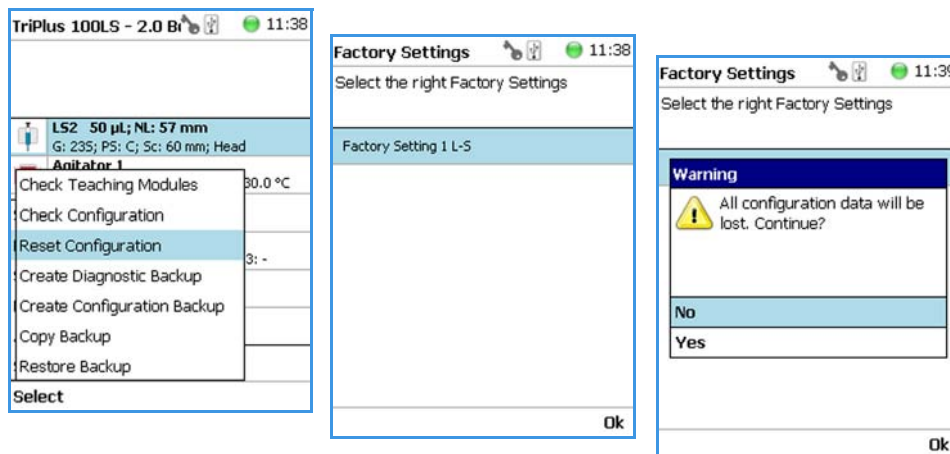

Create Diagnostic Backup

By using the command **Create Diagnostic Backup**, essential information from the current status of the TriPlus 100 Liquid Sampler system is extracted, and saved in an encrypted form on the SD card.

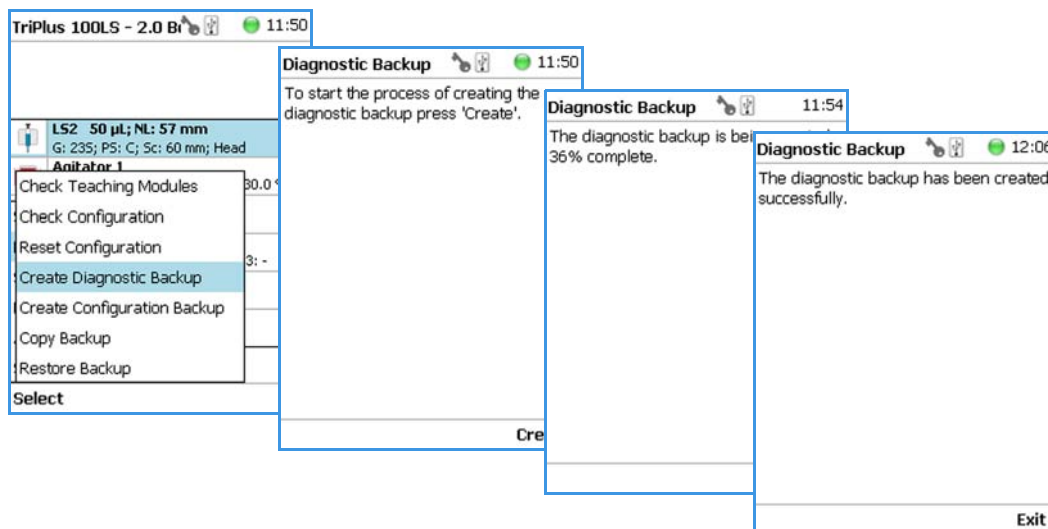

- The primary use of the Diagnostic Backup file is for supporting and troubleshooting a TriPlus 100 Liquid Sampler system. For this purpose it is necessary to send the file by e-mail to the Thermo Fisher Scientific technical support center: gc.gcms.customersupport@thermofisher.com, with the file description provide as well the Firmware version used.
Refer also to the chapter **Firmware** in the *TriPlus 100 Liquid Sampler Hardware Manual*.

The following software components are saved:

- **Application Software** — The Software of the application.
- **Device Firmware** — The Firmware of all active modules which are part of the specific TriPlus 100 Liquid Sampler system configuration
- **Configuration** (Data Base)
- **Presets** — Defines a model configuration such as liquid and headspace injection technique, and so on.

This tool is available in the **Extended User** and **Service** access levels. After successful creation of the **Diagnostic Backup**, copy the file directly onto the USB Stick. The creation of the Diagnostic Backup file, with extension ***.pack**, takes approximately eight minutes. The size of the file is in the range of 12 MB, depending on the configuration of the TriPlus 100 Liquid Sampler system.

The **Diagnostic Backup** file can also be used for a **Restore** procedure.

Create Configuration Backup

This command creates a configuration backup file of the TriPlus 100 Liquid Sampler system in its current status. This configuration backup is stored on the SD card installed on the control board. Refer also to the chapter **Firmware** in the *TriPlus 100 Liquid Sampler Hardware Manual*.

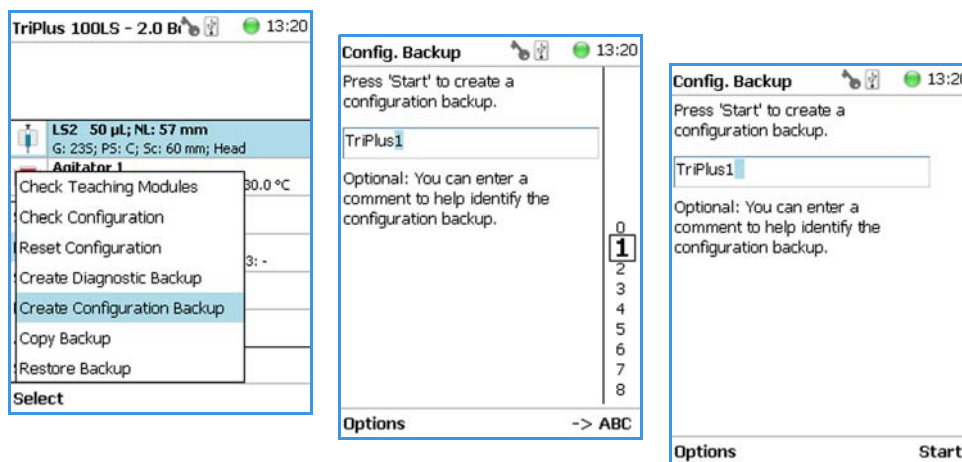

4 Maintenance Menu Items

Copy Backup

The command is available in all access levels. After successful creation of the Configuration Backup, copy the file directly onto the USB Stick. The creation of the Configuration Backup file does take approximately one to two minutes. The file size is in the range of 1.3 MB, depending on the TriPlus 100 Liquid Sampler system configuration. The file extension is ***.pack**.

The **Configuration Backup** file can also be used for a **Restore** procedure.

Copy Backup

Note Be aware that only one backup file can be stored on the SD card.

If for example a Diagnostic Backup file is created and directly followed by creating a **Configuration Backup** file, the first file (in this example the Diagnostic Backup file) will be overwritten. To save both files, it is necessary to copy each file immediately onto the USB Stick.

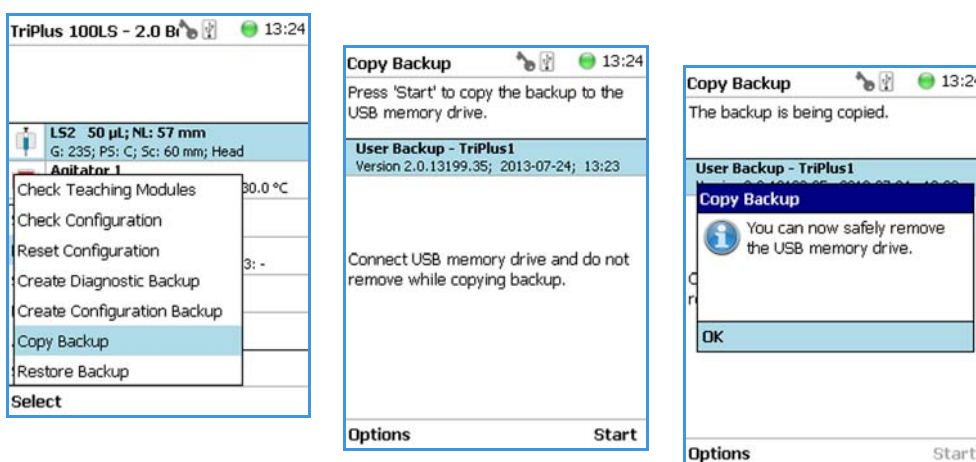

It is good practice to store the configuration backup in a safe place, if possible on a network-server. You must keep an authorized configuration backup outside of your premises.

To copy a configuration backup from the SD card, insert the USB stick into the connector USB Host on the back of the TriPlus 100 Liquid Sampler system. Refer also to the chapter **Firmware** in the *TriPlus 100 Liquid Sampler Hardware Manual*.

Restore Backup

The function **Restore** allows loading a **Backup** file saved from the same TriPlus 100 Liquid Sampler system back to the system. Only a Backup file (*.pack file) can be used. The key, the encryption of the Application, and the device Firmware files have to match. Refer also to the chapter **Firmware** in the *TriPlus 100 Liquid Sampler Hardware Manual*.

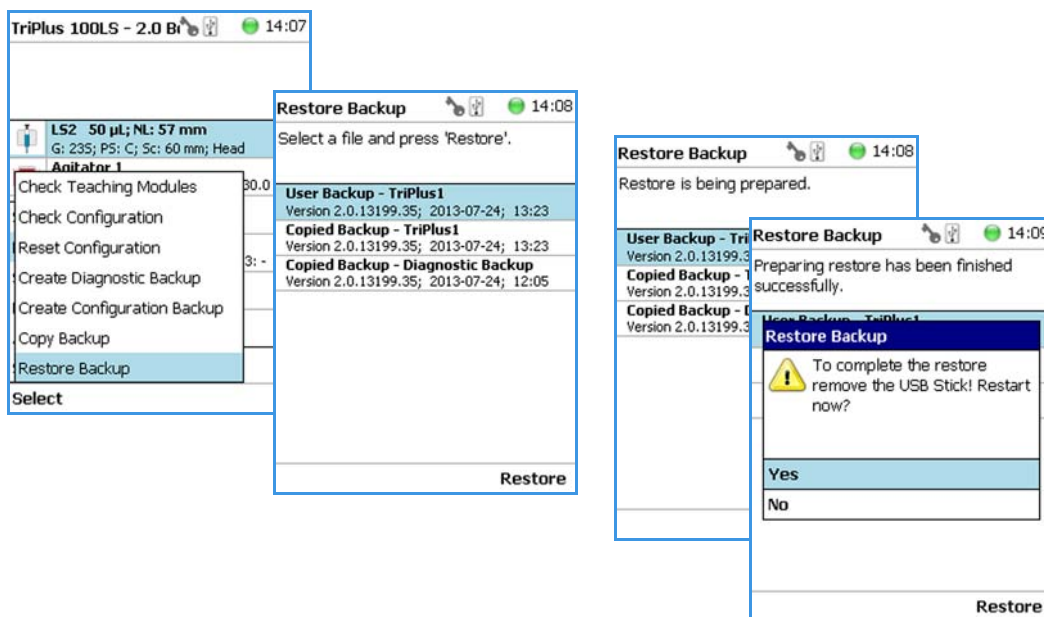

WARNING The two points mentioned are important:



- **Remove first the USB Stick** — The process of updating/downgrading would be started automatically if the USB drive would remain connected to the TriPlus 100 Liquid Sampler system, and a software file for update/downgrade (*.cont file) would be detected after rebooting the TriPlus 100 Liquid Sampler system.
- **TriPlus 100 Liquid Sampler must be restarted** — When selected, the instrument powers down and the software is rebooted automatically. It is not necessary to turn off the main power switch at the power supply.

The new software configuration will be activated after the next restart of the TriPlus 100 Liquid Sampler system.

Service Menu Item

This chapter describes the options of the **Service Menu** operated either with the Virtual Handheld Controller, or directly using the installed Handheld Controller.

Contents

- [Service Menu](#)
- [Installation Item](#)
- [Create New Tray System Item](#)

Service Menu

The Menu **Service** is only available under the **Extended User Level**. The menu contains the items **Installation** and **Create New Tray System**. The item **Installation** is a wizard that guides through the installation procedure covering all points, and controlling the status of the system. The **Create New Tray System** item is used during routine operation.

- See “Prerequisites” on page 128
- See “Installation Item” on page 129

Prerequisites

When the TriPlus 100 Liquid Sampler system is powered on, the **User Access Level** is always active by default. To enable access to the **Extended User Level** press the two **Menu Buttons** simultaneously, or press the two characters **A** and **B** simultaneously on the keyboard if you are working with a Virtual Handheld Controller. For more details, see “Access Levels” on page 47.

When the TriPlus 100 Liquid Sampler system is powered up the first time, the **Message Envelope** is shown in the Menu Screen Status Bar. See the example in Figure 85.

Figure 85. Changing Access Level

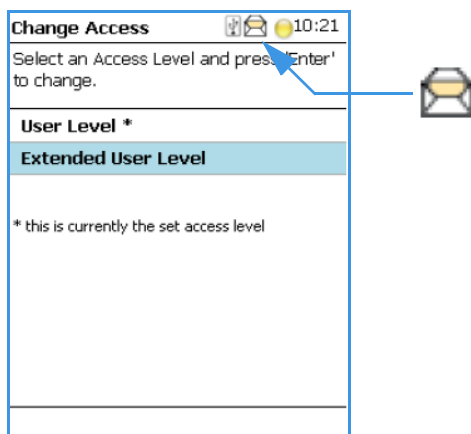

The reason for this message is that a TriPlus 100 Liquid Sampler system cannot be operated as long as the motors are not calibrated. The modules cannot operate if this step has not been completed.

When pending messages are indicated, verify the message. If the message can be explained with the concept as described above, click it away. For confirmation check that all cables from the active modules are properly connected.

Installation Item

Note During a new installation of the TriPlus 100 Liquid Sampler system, it is advisable to first configure the Passive modules before activating the **Installation Wizard Service**. One wizard item is Teaching Module. If the Passive modules, such as the Injector, Wash Module, and so on, are not yet configured, it will be necessary to restart this wizard again.

Note The **Quick Reference Guide** in the *TriPlus 100 Liquid Sampler Hardware Manual* shows the order of installation. Use this guide as reference.

Press the **Options** button to open the pull-up menu, and select the menu item **Service**; then select the list item **Installation** to start the wizard. See [Figure 86](#).

Figure 86. Selecting the Menu List Item Installation

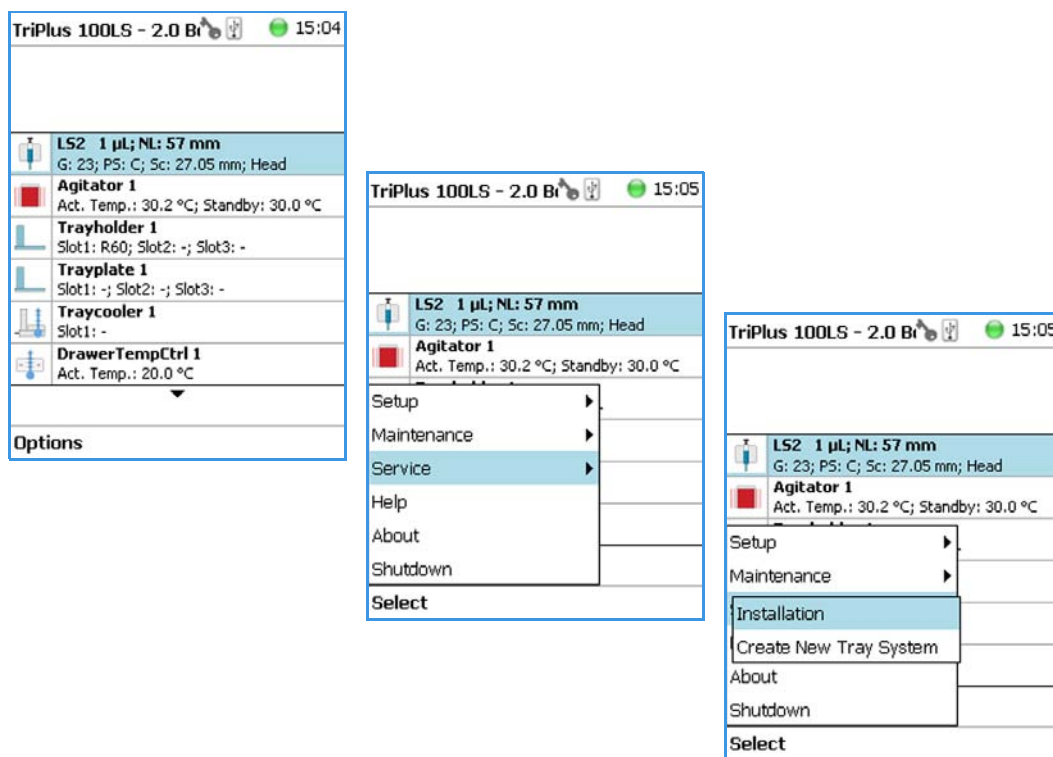

The **Installation** wizard begins with the basic setup items. Some of the list items can be accessed under the menu item **Setup**.

The **Installation** wizard includes twelve points. See [Figure 87](#). When the TriPlus 100 Liquid Sampler system is powered on for the first time, specific sections are grayed out until the section Calibration Motors has been completed. Each point ticks off as it is completed.

When the TriPlus 100 Liquid Sampler system is powered on for the first time, the wizard items that must be accomplished are active (black). The grayed out wizard items become active as soon as the system is calibrated (Calibrate Motors) and if the hardware configuration of the TriPlus 100 Liquid Sampler system requires these points.

Figure 87. Installation Wizard

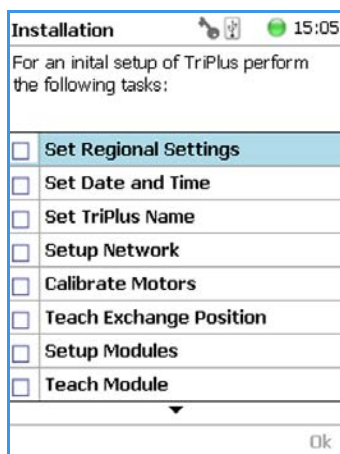

The eleven points to cover are:

- [“Set Regional Settings” on page 131](#)
- [“Set Date and Time” on page 132](#)
- [“Set TriPlus Name” on page 134](#)
- [“Setup Network” on page 135](#)
- [“Calibrate Motors” on page 138](#)
- [“Teach Exchange Position” on page 139](#)
- [“Setup Module” on page 140](#)
- [“Teach Module” on page 141](#)
- [“Check Teaching Modules” on page 145](#)
- [“Exchange Syringe” on page 146](#)
- [“Create a Configuration Backup File” on page 147](#)

Set Regional Settings

❖ To set regional setting

1. Select the wizard item **Set Regional Setting** to adjust the language and the region.
See [Figure 88](#).

Figure 88. Wizard Item Set Regional Settings

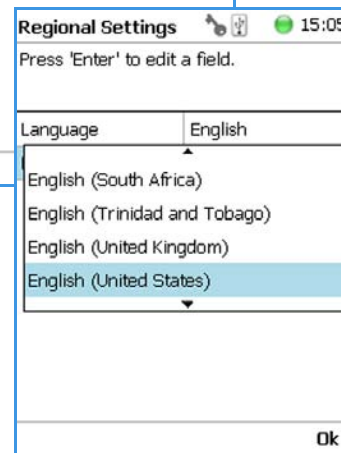
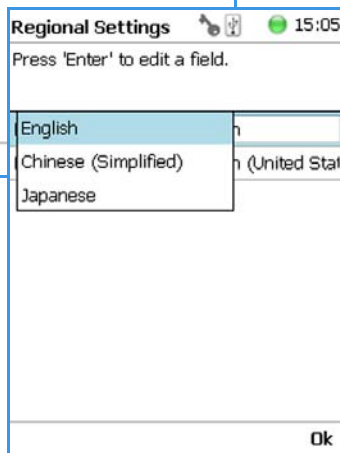
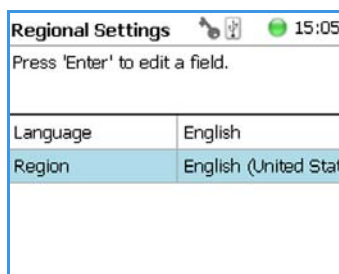
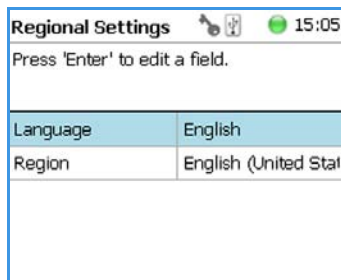
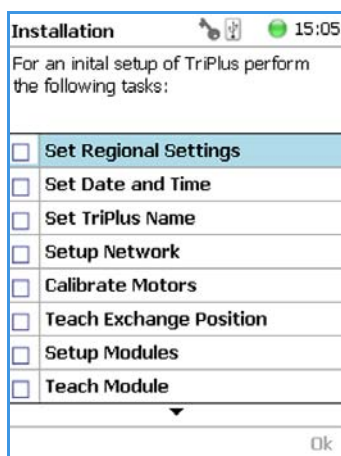

Table 63. Set Regional Settings

| Item | Description |
|------------------|---|
| Language | English is the default language. |
| Regional Setting | Corresponds to the country settings of the computer operating system. The country setting mainly influences formatting such as for dates and numbers. |



IMPORTANT When a Set Regional Setting parameter is changed, a reboot of the system is required. Please note that the Regional Settings are active for the Handheld Controller only, the Virtual Handheld Controller is dependent on the settings of the computer operating system.

Set Date and Time

❖ To set date and time

1. Select the wizard item **Set Date and Time** to adjust the date and time. See [Figure 89](#) and [Table 64](#).

Figure 89. Wizard Item Set Date and Time

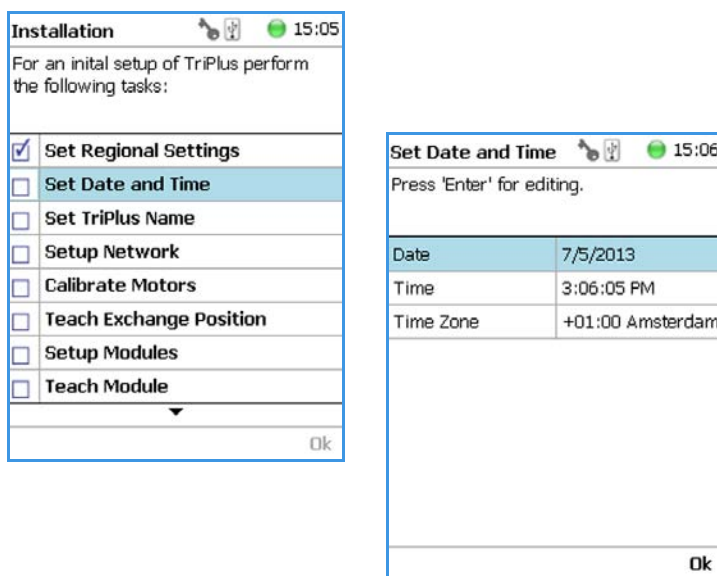
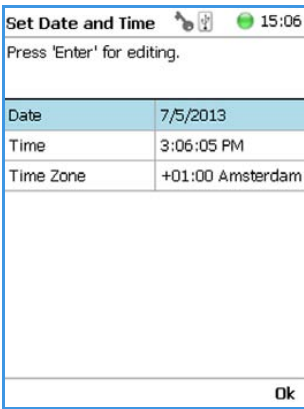
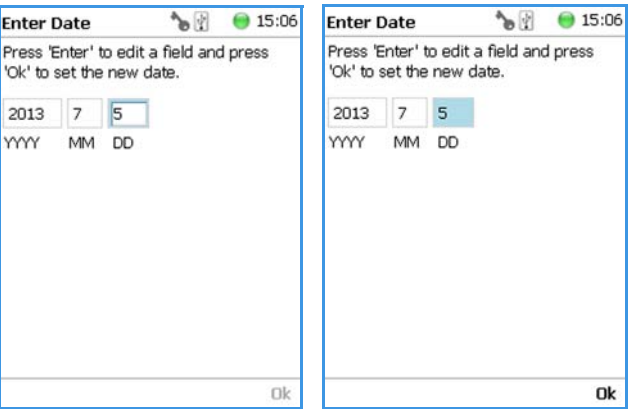

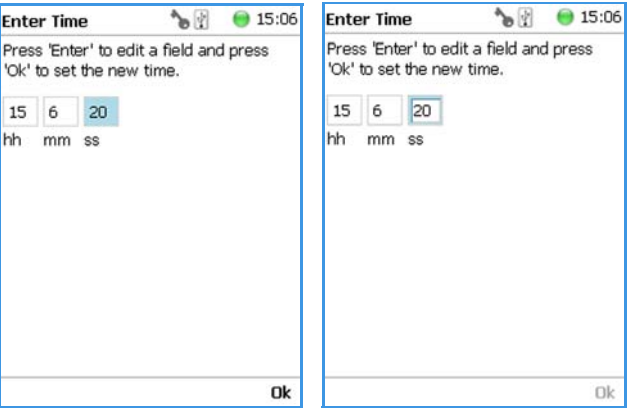
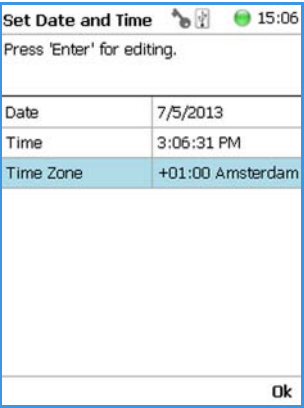
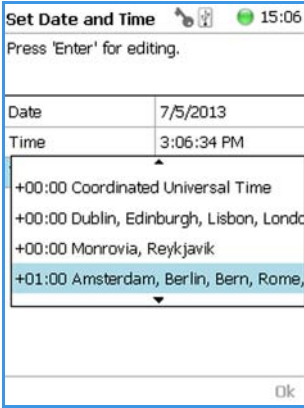

Table 64. Set Date and Time Parameters

| Item | Description |
|--|---|
| <p>Date</p>  | <p>The format is: yyyy/mm/dd</p>  |
| <p>Time</p>  | <p>The format is hh:mm:ss</p>  |
| <p>Time Zone</p>  | <p>Greenwich Mean Time (GMT) plus or minus the time deviation (in hours) from Greenwich standard time.</p>  |

Set TriPlus Name

❖ To set TriPlus 100 Liquid Sampler name

1. Select the wizard item **Set TriPlus Name** to set a name for identifying the TriPlus 100 Liquid Sampler system. See [Figure 90](#) and [Table 65](#).

Figure 90. Wizard Item Set TriPlus 100 Liquid Sampler Name

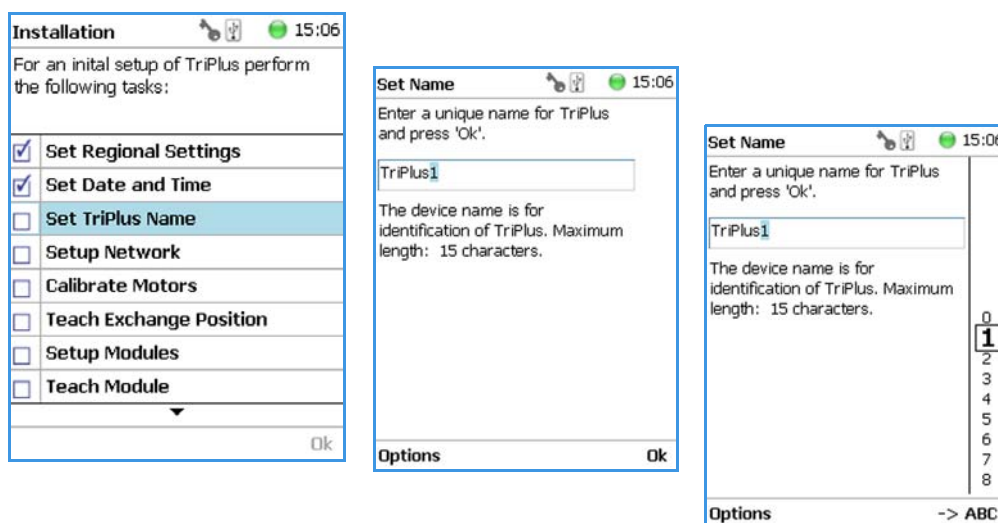

2. Press **Enter** to receive the alphabetical selection of 15 characters maximum or press the **Default Action** button to change from capital to lower case characters or to numbers.

Note The name must start with an alphabetical character, and end with an alphanumerical character. Special characters or spaces cannot be used to start or end the name.

3. Press **Options** to access the list items **Insert**, or **Delete Character**, or **Clear Text**.
4. Press **Ok** when finished.

Table 65. Set TriPlus 100 Liquid Sampler Name Parameter

| Item | Description |
|------------------|---|
| Set Sampler Name | Sets a unique name for the TriPlus 100 Liquid Sampler system. This name will be stored and is used for identification of the system. |
| Insert Character | Allows insertion of a character. Press Enter to receive the selection of capital letters. Pressing the Default Action button will switch to lower case characters or to the alphanumerical selection. |
| Delete Character | Deletes the selected character. |
| Clear Text | Clears the full text. |

Setup Network

❖ To perform Setup Network

1. Select the wizard item **Setup Network** to enable a network communication from the system to the computer, TCP/IP. See [Figure 91](#) and [Table 66](#).
2. Select either the mode **DHCP** or enter a unique fixed IP Address.
3. Press **Ok** when finished.

Figure 91. Wizard Item Setup Network

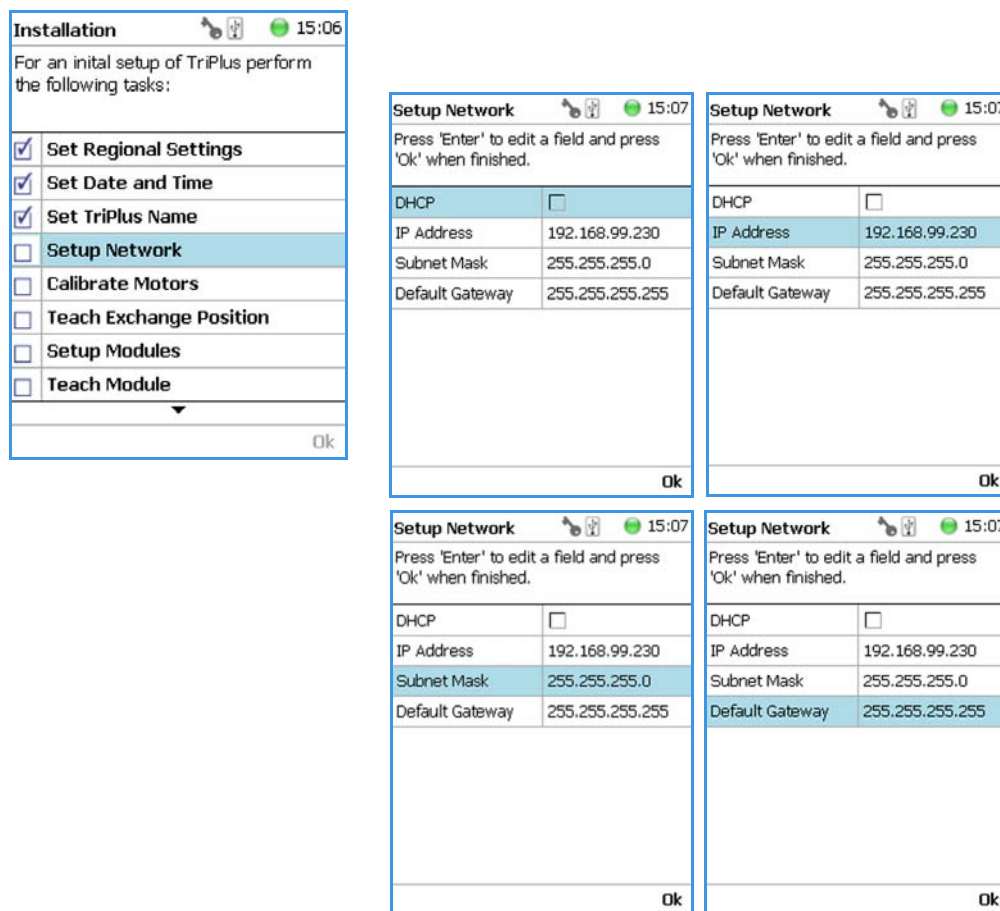

Table 66. Setup Network Parameters (Sheet 1 of 2)

| Item | Description |
|---------------|--|
| Setup Network | Defines the Network communication parameters. |
| DHCP | Dynamic Host Configuration Protocol. If activated, an IP Address is dynamically sought throughout the available network. It is advisable not to use the DHCP mode but to use a fixed IP Address. |

Table 66. Setup Network Parameters (Sheet 2 of 2)

| Item | Description |
|-----------------|---|
| IP Address | The IP Address is a fixed system address. The IP Address is often provided by the network administrator. Default address for the TriPlus 100 Liquid Sampler system is 192.168.99.230 |
| Subnet Mask | The Subnet Mask is used for network configuration, it must be provided by the network administrator. Default address for the TriPlus 100 Liquid Sampler system is 255.255.255.0. |
| Default Gateway | Gateway is used if independent networks must communicate interactively. Communication within the network is provided by a hub or switch, defined as the Gateway . Do not assign a Default Gateway address. |

When the network cable is not connected, and a LAN communication is not established, the message **Not Network Connection** will appear.

The system will recognize that no network communication is established or possible. A corresponding error message will appear.

1. Check the connections of the LAN cable. The default addresses is visible after reentering the **Setup Network** screen.
2. Check the LEDs on the Ethernet connector at the back of the TriPlus 100 Liquid Sampler system:

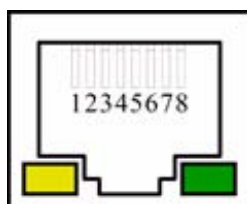

- **The LED on the left** — It is the **Status LED**. Yellow light indicates that the current is applied to the connector.
 - **The LED on the right** — Indicates the Ethernet communication status. Green light blinking status indicates that the Ethernet communication is established.
3. When the settings have to be changed, select one Network parameter after the other, and enter the required numbers. The next examples show the default values.

Note When the LAN communication is not established, newly entered IP address numbers are not stored.

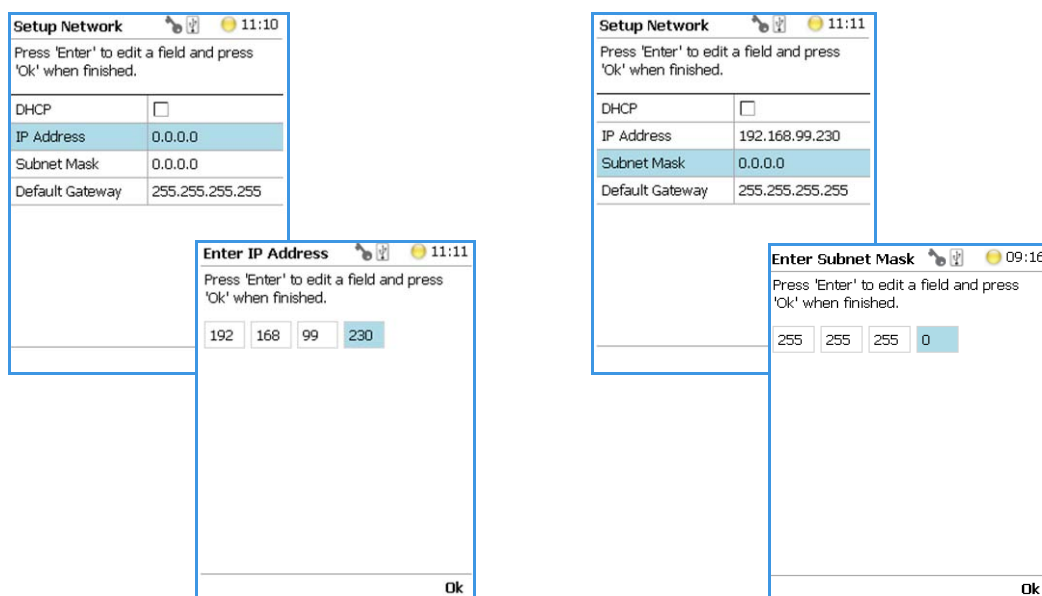

For more information refer to **Setting Up Network Interface** in the *TriPlus 100 Liquid Sampler Hardware Manual*.

In order to select the required network setup according to the laboratory setting, the following possibilities are available:

- **Direct connection** — The TriPlus 100 Liquid Sampler system is directly connected to the computer via the LAN cable. There is no corporate network or router connection.
 - IP Address TriPlus 100 Liquid Sampler system: 192.168.99.230
 - IP Address computer: 192.168.99.210
 - Subnet Mask: 255.255.255.0
 - Default Gateway: not required, leave the field empty (if an address is entered, it will not be used)
- **Corporate Network with DHCP Protocol** — Ask the network administrator to verify and integrate the setup within the corporate network.
Select the DHCP Protocol; the network will assign an IP Address and a Subnet Mask to the TriPlus 100 Liquid Sampler system.
- **Corporate Network with Fixed IP Address** — Ask the network administrator to provide the IP Address, Subnet Mask, and Default Gateway to configure the TriPlus 100 Liquid Sampler system within the corporate network

Calibrate Motors

The calibration of the motors is basically a check to determine whether the mechanical stop points of the various axes can be found reliably. A clearance distance (offset) from the mechanical stop point is assigned and stored as the electronic stop point. This calibration of the axes is mandatory and ensures reliable performance.

This step is repeated when a motor has failed, has been replaced, or when any other major error has occurred. This calibration task brings the TriPlus 100 Liquid Sampler system back to reliable operation.

❖ To calibrate the motors

1. Select the wizard item **Calibrate Motors** and follow the dialog. See [Figure 92](#).

Figure 92. Wizard Item Calibrate Motors and Starting Calibration Wizard

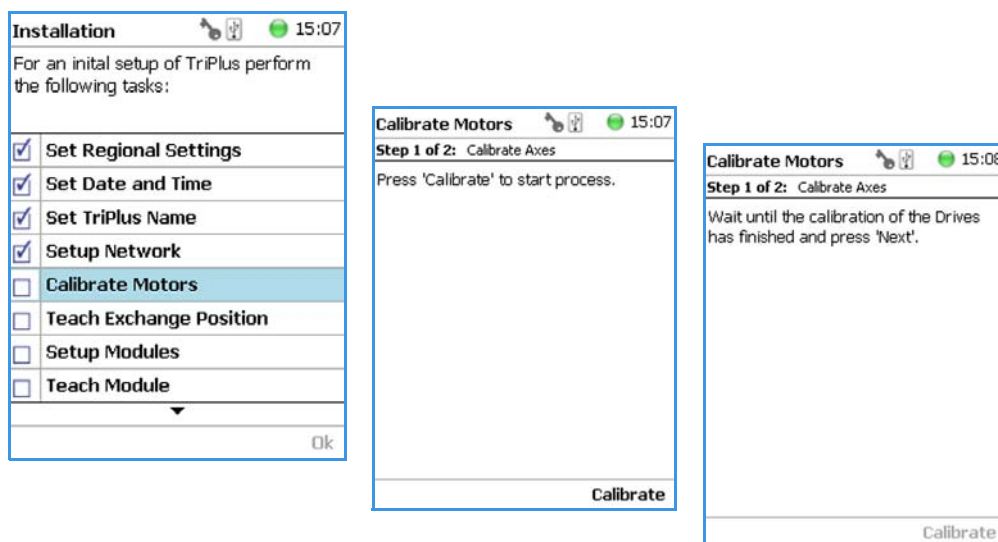

2. Press **Calibrate** to start the calibration process.
3. Press **Next** to continue. When the calibration finishes, press **Ok**. The head of the TriPlus 100 Liquid Sampler system moves back to the Home position.



Teach Exchange Position

The home position is the position the head is moved to at the end of a task, for example when it returns to standby. By default, this position is at the far left side of the X-Axis.

It is highly recommended to optimize this position according to the final configuration of each system.

Note The optimization of the Exchange Position is done mainly to get easy access to the Syringe Adapter while avoiding syringe needle bending or syringe glass barrel breaking if the position has restricted access. It protects the operator during the process of exchanging the syringe from contact with heated zones. Unnecessary bending or stretching should be avoided prevent falls.

The Home Position optimization is performed for several reasons as:

- For convenience, in order to have the head in a preferred standby position.
- To save time minimizing the movement of the head to a module.
- For avoiding the collision of the head and a module.

❖ To teach the exchange position

1. Select the wizard item **Teach Exchange Position** and follow the dialog. See [Figure 93](#).

Figure 93. Wizard Item Teach Exchange Position

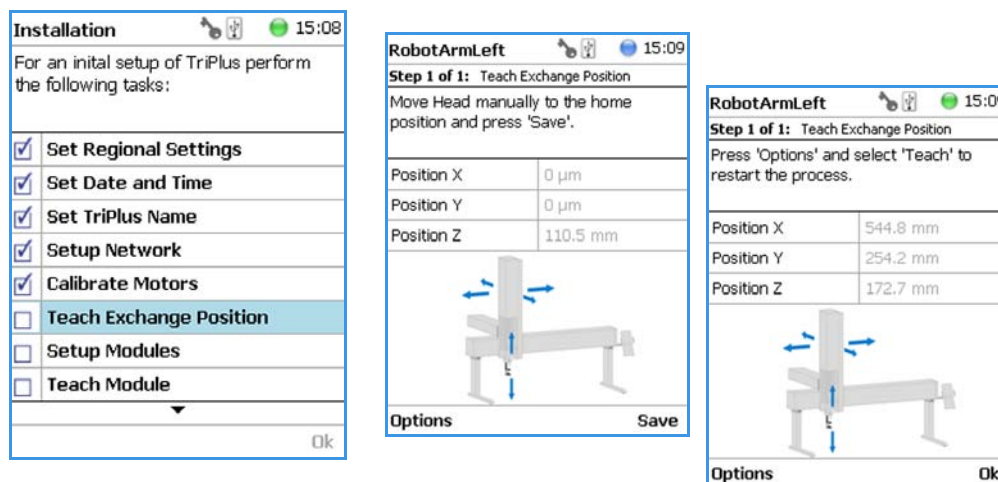

2. Move the head to the required position and save the X-, Y-, Z- Axes Positions as the new Home Position. **Save** to memorize.

To restart the process, select **Options | Teach Exchange Position**.

Setup Module

This allows you to predefine the parameters from a module. Typically, this process is done at first installation of the TriPlus 100 Liquid Sampler system. See [Figure 94](#).

Figure 94. Wizard Item Setup Module

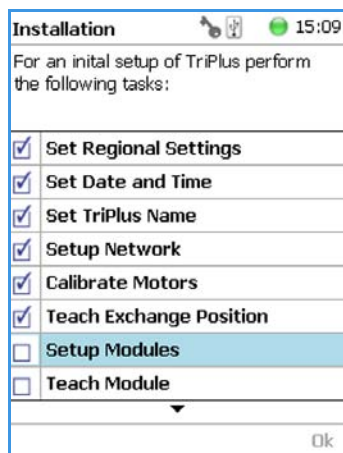

❖ To set up a module

The example below shows the steps for defining the parameters for the **Agitator**:

1. Select the **Cover Plate Type**, the **Reserved Position**, and **Vial type** used for the Agitator:

- **Cover Plate Type** — Specify the type of cover plate.
 - **Not Specified** — Prohibits the execution of a run.
 - **Standard** — Cover without holes.
 - **Perforated** — Cover with 6 holes to enable Syringe Needle penetration through the cover into the vial inserted in the Agitator.

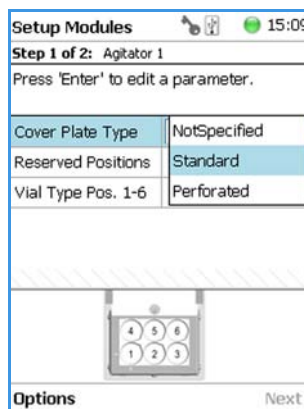
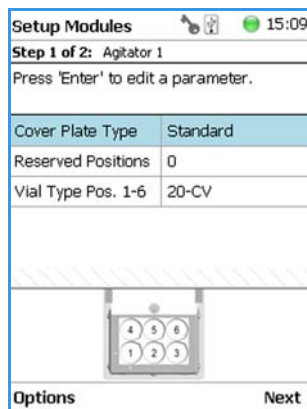

- **Reserved Position** — To reserve one or more positions in the Agitator for a source vial. The reservation for a vial starts with **Vial Position 6** and counts backwards.

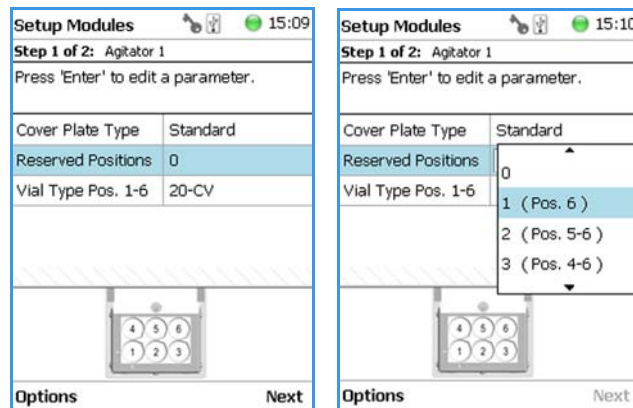

- **Vial Type** — Selects the type of vials used for the Agitator. If the Vial Type must be changed during routine application, this can be done at any time by going to the Start Screen, selecting the menu item **Agitator**, scrolling down to the list item **Vial Type** and selecting another Vial Type.

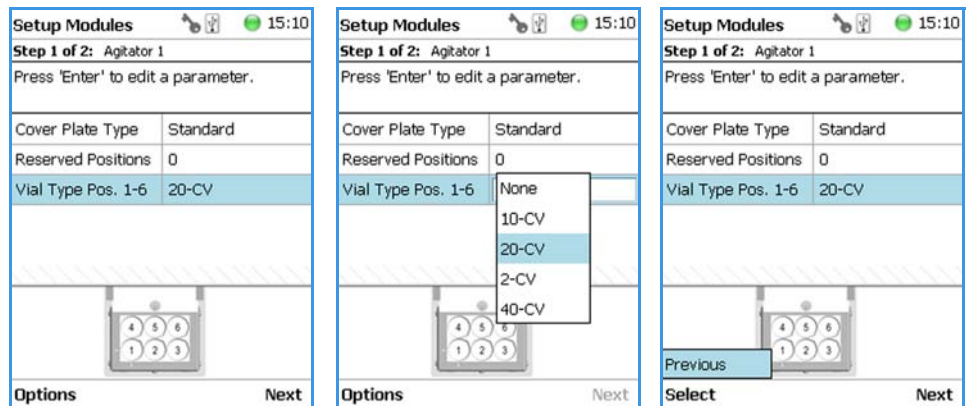

Teach Module

The term Teaching is used for the definition of the X-, Y-, and Z-Axis positions for each module. Refer also to **TriPlus 100 Liquid Sampler Defining Object Positions** in the *TriPlus 100 Liquid Sampler Hardware Manual*.

Note The difference between **Active** and **Passive** modules are:

- The **Active** modules are recognized automatically by the system when connected to the Bus and at the next restart of the system.
- The **Passive** modules are not automatically recognized; they have to be added to the configuration. The passive modules, such as Tray Holder, Wash Station, and so on, must be added first.

❖ **To teach the module**

1. Select the wizard item **Teach Module**. A dialog guides the operator through this teaching wizard. Upon starting the wizard, the TriPlus 100 Liquid Sampler system automatically turns off the current to enable a manual movement of the Injection Unit to the various modules configured with the system. See [Figure 95](#).

Figure 95. Wizard Item Teach Module

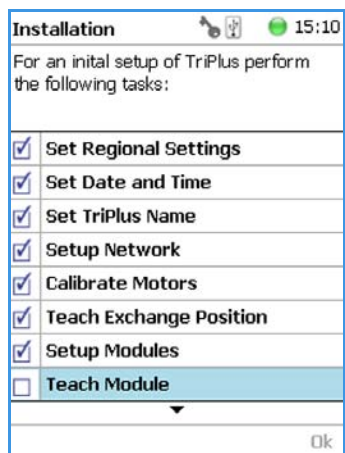

2. During the teaching process, it is always possible to demand a fine tuning or to go back to a previous position or module. See the various possibilities under the **Options** pull-up menu.



CAUTION It is advisable to hold the Y-Axis with one hand and with the other hand hold the tool body to move the TriPlus 100 Liquid Sampler system Injection Unit in a controlled way to the teaching position.

Do NOT hold the Needle Guide to move the TriPlus 100 Liquid Sampler system Injection Unit. This part is mechanically flexible and could lead to misalignment.

3. When the wizard is started, the first module is displayed, and an arrow indicates the teaching position. Follow the instructions given.
As a general description, move the Injection Unit manually to the indicated teaching position, and adjust the lower needle guide perfectly within the center of the lunette ring. Without the magnetic ring attached, use the inner ring for teaching.
4. The **Lower Needle Guide** should be centered on the lunette with the bottom of the Lower Needle Guide lightly touching its surface.
For modules without a lunette, such as the Agitator, it is necessary to insert a vial (with the corresponding adapter if required), and use the vial cap surface as the reference for the Z-Axis value.
5. When you are satisfied with the teaching, press **Save** and continue by pressing **Next** to get to the following module. If in doubt, proceed with the fine tuning.
The teaching process for the active modules are described in chapter **TriPlus 100 Liquid Sampler Defining Object Positions** in the *TriPlus 100 Liquid Sampler Hardware Manual*.

The Teach position of each module is reported in [Table 67](#).

Opening the pull-up menu **Options** provides the list items specific to each module. The pull-up menu **Previous** moves one step back to the previous module and verifies the teaching position again.

Table 67. Teach Modules Steps (Sheet 1 of 2)





| Steps | | | | | | | | | | | | | | | | | | | | | | | | | | | | | | | | | | | | | | |
|--|-----------|--------------|--------------|---|----------|----------|---|----------|----------|---|----------|----------|---|------|-----------|--------------|---|----------|----------|---|---------|---------|---|----------|----------|--|------|-----------|--------------|---|----------|----------|---|----------|----------|---|----------|----------|
| <p>Teach Modules 15:11</p> <p>Step 1 of 18: Teach Agitator 1</p> <p>Press 'Enter' to manually adjust the position or press 'Next'.</p> <table border="1"> <thead> <tr> <th>Pos.</th> <th>Actual TP</th> <th>Needle Guide</th> </tr> </thead> <tbody> <tr> <td>X</td> <td>576.9 mm</td> <td>576.9 mm</td> </tr> <tr> <td>Y</td> <td>28.8 mm</td> <td>28.8 mm</td> </tr> <tr> <td>Z</td> <td>156.1 mm</td> <td>156.1 mm</td> </tr> </tbody> </table>  <p>Options Next</p> | Pos. | Actual TP | Needle Guide | X | 576.9 mm | 576.9 mm | Y | 28.8 mm | 28.8 mm | Z | 156.1 mm | 156.1 mm | <p>Teach Modules 15:12</p> <p>Step 2 of 18: Teach Vortexer 1</p> <p>Press 'Enter' to manually adjust the position or press 'Next'.</p> <table border="1"> <thead> <tr> <th>Pos.</th> <th>Actual TP</th> <th>Needle Guide</th> </tr> </thead> <tbody> <tr> <td>X</td> <td>451.9 mm</td> <td>451.9 mm</td> </tr> <tr> <td>Y</td> <td>2.1 mm</td> <td>2.1 mm</td> </tr> <tr> <td>Z</td> <td>258.5 mm</td> <td>258.5 mm</td> </tr> </tbody> </table>  <p>Options Next</p> | Pos. | Actual TP | Needle Guide | X | 451.9 mm | 451.9 mm | Y | 2.1 mm | 2.1 mm | Z | 258.5 mm | 258.5 mm | <p>Teach Modules 15:12</p> <p>Step 3 of 18: Teach Barcode Reader 1</p> <p>Press 'Enter' to manually adjust the position or press 'Next'.</p> <table border="1"> <thead> <tr> <th>Pos.</th> <th>Actual TP</th> <th>Needle Guide</th> </tr> </thead> <tbody> <tr> <td>X</td> <td>349.5 mm</td> <td>349.5 mm</td> </tr> <tr> <td>Y</td> <td>114.0 mm</td> <td>114.0 mm</td> </tr> <tr> <td>Z</td> <td>125.1 mm</td> <td>125.1 mm</td> </tr> </tbody> </table>  <p>Options Next</p> | Pos. | Actual TP | Needle Guide | X | 349.5 mm | 349.5 mm | Y | 114.0 mm | 114.0 mm | Z | 125.1 mm | 125.1 mm |
| Pos. | Actual TP | Needle Guide | | | | | | | | | | | | | | | | | | | | | | | | | | | | | | | | | | | | |
| X | 576.9 mm | 576.9 mm | | | | | | | | | | | | | | | | | | | | | | | | | | | | | | | | | | | | |
| Y | 28.8 mm | 28.8 mm | | | | | | | | | | | | | | | | | | | | | | | | | | | | | | | | | | | | |
| Z | 156.1 mm | 156.1 mm | | | | | | | | | | | | | | | | | | | | | | | | | | | | | | | | | | | | |
| Pos. | Actual TP | Needle Guide | | | | | | | | | | | | | | | | | | | | | | | | | | | | | | | | | | | | |
| X | 451.9 mm | 451.9 mm | | | | | | | | | | | | | | | | | | | | | | | | | | | | | | | | | | | | |
| Y | 2.1 mm | 2.1 mm | | | | | | | | | | | | | | | | | | | | | | | | | | | | | | | | | | | | |
| Z | 258.5 mm | 258.5 mm | | | | | | | | | | | | | | | | | | | | | | | | | | | | | | | | | | | | |
| Pos. | Actual TP | Needle Guide | | | | | | | | | | | | | | | | | | | | | | | | | | | | | | | | | | | | |
| X | 349.5 mm | 349.5 mm | | | | | | | | | | | | | | | | | | | | | | | | | | | | | | | | | | | | |
| Y | 114.0 mm | 114.0 mm | | | | | | | | | | | | | | | | | | | | | | | | | | | | | | | | | | | | |
| Z | 125.1 mm | 125.1 mm | | | | | | | | | | | | | | | | | | | | | | | | | | | | | | | | | | | | |
| <p>Agitator Teaching Position Vortexer Teaching Position Barcode Reader Teaching Position</p> | | | | | | | | | | | | | | | | | | | | | | | | | | | | | | | | | | | | | | |
| <p>Teach Modules 15:12</p> <p>Step 4 of 18: Teach Injector SSL</p> <p>Press 'Enter' to manually adjust the position or press 'Next'.</p> <table border="1"> <thead> <tr> <th>Pos.</th> <th>Actual TP</th> <th>Needle Guide</th> </tr> </thead> <tbody> <tr> <td>X</td> <td>44.2 mm</td> <td>44.2 mm</td> </tr> <tr> <td>Y</td> <td>115.5 mm</td> <td>115.5 mm</td> </tr> <tr> <td>Z</td> <td>156.3 mm</td> <td>156.3 mm</td> </tr> </tbody> </table>  <p>Options Next</p> | Pos. | Actual TP | Needle Guide | X | 44.2 mm | 44.2 mm | Y | 115.5 mm | 115.5 mm | Z | 156.3 mm | 156.3 mm | <p>Teach Modules 15:13</p> <p>Step 6 of 18: Teach Obstacle OCI</p> <p>Press 'Enter' to manually adjust the position or press 'Next'.</p> <table border="1"> <thead> <tr> <th>Pos.</th> <th>Actual TP</th> <th>Needle Guide</th> </tr> </thead> <tbody> <tr> <td>X</td> <td>203.1 mm</td> <td>203.1 mm</td> </tr> <tr> <td>Y</td> <td>21.2 mm</td> <td>21.2 mm</td> </tr> <tr> <td>Z</td> <td>251.0 mm</td> <td>251.0 mm</td> </tr> </tbody> </table>  <p>Options Next</p> | Pos. | Actual TP | Needle Guide | X | 203.1 mm | 203.1 mm | Y | 21.2 mm | 21.2 mm | Z | 251.0 mm | 251.0 mm | <p>Teach Modules 15:14</p> <p>Step 7 of 18: Teach Solvent 1</p> <p>Press 'Enter' to manually adjust the position or press 'Next'.</p> <table border="1"> <thead> <tr> <th>Pos.</th> <th>Actual TP</th> <th>Needle Guide</th> </tr> </thead> <tbody> <tr> <td>X</td> <td>46.2 mm</td> <td>46.2 mm</td> </tr> <tr> <td>Y</td> <td>114.6 mm</td> <td>114.6 mm</td> </tr> <tr> <td>Z</td> <td>156.1 mm</td> <td>156.1 mm</td> </tr> </tbody> </table>  <p>Options Next</p> | Pos. | Actual TP | Needle Guide | X | 46.2 mm | 46.2 mm | Y | 114.6 mm | 114.6 mm | Z | 156.1 mm | 156.1 mm |
| Pos. | Actual TP | Needle Guide | | | | | | | | | | | | | | | | | | | | | | | | | | | | | | | | | | | | |
| X | 44.2 mm | 44.2 mm | | | | | | | | | | | | | | | | | | | | | | | | | | | | | | | | | | | | |
| Y | 115.5 mm | 115.5 mm | | | | | | | | | | | | | | | | | | | | | | | | | | | | | | | | | | | | |
| Z | 156.3 mm | 156.3 mm | | | | | | | | | | | | | | | | | | | | | | | | | | | | | | | | | | | | |
| Pos. | Actual TP | Needle Guide | | | | | | | | | | | | | | | | | | | | | | | | | | | | | | | | | | | | |
| X | 203.1 mm | 203.1 mm | | | | | | | | | | | | | | | | | | | | | | | | | | | | | | | | | | | | |
| Y | 21.2 mm | 21.2 mm | | | | | | | | | | | | | | | | | | | | | | | | | | | | | | | | | | | | |
| Z | 251.0 mm | 251.0 mm | | | | | | | | | | | | | | | | | | | | | | | | | | | | | | | | | | | | |
| Pos. | Actual TP | Needle Guide | | | | | | | | | | | | | | | | | | | | | | | | | | | | | | | | | | | | |
| X | 46.2 mm | 46.2 mm | | | | | | | | | | | | | | | | | | | | | | | | | | | | | | | | | | | | |
| Y | 114.6 mm | 114.6 mm | | | | | | | | | | | | | | | | | | | | | | | | | | | | | | | | | | | | |
| Z | 156.1 mm | 156.1 mm | | | | | | | | | | | | | | | | | | | | | | | | | | | | | | | | | | | | |
| <p>GC Injector Teaching Position Obstacle Teaching Position Large Solvent Station Teaching Position</p> | | | | | | | | | | | | | | | | | | | | | | | | | | | | | | | | | | | | | | |
| <p>Obstacle is a module from another device, for example the Thermo Conductivity Detector (TCD) from a GC system. If a module exceeds a certain height, it could get in the path way of the TriPlus 100 Liquid Sampler system. The dimension and the position of the obstacle can be defined. The TriPlus 100 Liquid Sampler excludes this area from the allowed path way and bypasses it.</p> | | | | | | | | | | | | | | | | | | | | | | | | | | | | | | | | | | | | | | |

Table 67. Teach Modules Steps (Sheet 2 of 2)

| Steps | | | | | | | | | | | | | | | | | | | | | | | | | | | | | | | | | | | | | | |
|---|--|--|--------------|---|----------|----------|---|----------|----------|---|----------|----------|--|------|-----------|--------------|---|----------|----------|---|----------|----------|---|----------|----------|---|------|-----------|--------------|---|----------|----------|---|----------|----------|---|----------|----------|
| <p>Teach Modules 15:14</p> <p>Step 8 of 18: Teach DrawerTempCtrl 1</p> <p>Press 'Enter' to manually adjust the position or press 'Next'.</p> <table border="1"> <thead> <tr> <th>Pos.</th> <th>Actual TP</th> <th>Needle Guide</th> </tr> </thead> <tbody> <tr> <td>X</td> <td>451.6 mm</td> <td>451.6 mm</td> </tr> <tr> <td>Y</td> <td>90.1 mm</td> <td>90.1 mm</td> </tr> <tr> <td>Z</td> <td>305.6 mm</td> <td>305.6 mm</td> </tr> </tbody> </table>  <p>Options Next</p> | Pos. | Actual TP | Needle Guide | X | 451.6 mm | 451.6 mm | Y | 90.1 mm | 90.1 mm | Z | 305.6 mm | 305.6 mm | <p>Teach Modules 15:15</p> <p>Step 9 of 18: Teach Traycooler 1</p> <p>Press 'Enter' to manually adjust the position or press 'Next'.</p> <table border="1"> <thead> <tr> <th>Pos.</th> <th>Actual TP</th> <th>Needle Guide</th> </tr> </thead> <tbody> <tr> <td>X</td> <td>231.3 mm</td> <td>231.3 mm</td> </tr> <tr> <td>Y</td> <td>264.4 mm</td> <td>264.4 mm</td> </tr> <tr> <td>Z</td> <td>175.2 mm</td> <td>175.2 mm</td> </tr> </tbody> </table>  <p>Options Next</p> | Pos. | Actual TP | Needle Guide | X | 231.3 mm | 231.3 mm | Y | 264.4 mm | 264.4 mm | Z | 175.2 mm | 175.2 mm | <p>Teach Modules 15:15</p> <p>Step 11 of 18: Teach Trayplate 1</p> <p>Move the Head to the teach point and press 'Save' when finished.</p> <table border="1"> <thead> <tr> <th>Pos.</th> <th>Actual TP</th> <th>Needle Guide</th> </tr> </thead> <tbody> <tr> <td>X</td> <td>377.0 mm</td> <td>418.2 mm</td> </tr> <tr> <td>Y</td> <td>261.6 mm</td> <td>264.4 mm</td> </tr> <tr> <td>Z</td> <td>239.3 mm</td> <td>234.4 mm</td> </tr> </tbody> </table>  <p>Options Save</p> | Pos. | Actual TP | Needle Guide | X | 377.0 mm | 418.2 mm | Y | 261.6 mm | 264.4 mm | Z | 239.3 mm | 234.4 mm |
| Pos. | Actual TP | Needle Guide | | | | | | | | | | | | | | | | | | | | | | | | | | | | | | | | | | | | |
| X | 451.6 mm | 451.6 mm | | | | | | | | | | | | | | | | | | | | | | | | | | | | | | | | | | | | |
| Y | 90.1 mm | 90.1 mm | | | | | | | | | | | | | | | | | | | | | | | | | | | | | | | | | | | | |
| Z | 305.6 mm | 305.6 mm | | | | | | | | | | | | | | | | | | | | | | | | | | | | | | | | | | | | |
| Pos. | Actual TP | Needle Guide | | | | | | | | | | | | | | | | | | | | | | | | | | | | | | | | | | | | |
| X | 231.3 mm | 231.3 mm | | | | | | | | | | | | | | | | | | | | | | | | | | | | | | | | | | | | |
| Y | 264.4 mm | 264.4 mm | | | | | | | | | | | | | | | | | | | | | | | | | | | | | | | | | | | | |
| Z | 175.2 mm | 175.2 mm | | | | | | | | | | | | | | | | | | | | | | | | | | | | | | | | | | | | |
| Pos. | Actual TP | Needle Guide | | | | | | | | | | | | | | | | | | | | | | | | | | | | | | | | | | | | |
| X | 377.0 mm | 418.2 mm | | | | | | | | | | | | | | | | | | | | | | | | | | | | | | | | | | | | |
| Y | 261.6 mm | 264.4 mm | | | | | | | | | | | | | | | | | | | | | | | | | | | | | | | | | | | | |
| Z | 239.3 mm | 234.4 mm | | | | | | | | | | | | | | | | | | | | | | | | | | | | | | | | | | | | |
| <p>Temperature Controlled Drawer Stack Teaching Position</p> | <p>Tray Cooler Holder Teaching Position</p> | <p>Standard Holder Teaching Position</p> | | | | | | | | | | | | | | | | | | | | | | | | | | | | | | | | | | | | |
| <p>Teach Modules 15:16</p> <p>Step 12 of 18: Teach Solvent Reservo</p> <p>Press 'Enter' to manually adjust the position or press 'Next'.</p> <table border="1"> <thead> <tr> <th>Pos.</th> <th>Actual TP</th> <th>Needle Guide</th> </tr> </thead> <tbody> <tr> <td>X</td> <td>44.1 mm</td> <td>44.1 mm</td> </tr> <tr> <td>Y</td> <td>117.4 mm</td> <td>117.4 mm</td> </tr> <tr> <td>Z</td> <td>156.2 mm</td> <td>156.2 mm</td> </tr> </tbody> </table>  <p>Options Next</p> | Pos. | Actual TP | Needle Guide | X | 44.1 mm | 44.1 mm | Y | 117.4 mm | 117.4 mm | Z | 156.2 mm | 156.2 mm | <p>Teach Modules 15:16</p> <p>Step 14 of 18: Teach Waste Vial 1</p> <p>Press 'Enter' to manually adjust the position or press 'Next'.</p> <table border="1"> <thead> <tr> <th>Pos.</th> <th>Actual TP</th> <th>Needle Guide</th> </tr> </thead> <tbody> <tr> <td>X</td> <td>44.1 mm</td> <td>44.1 mm</td> </tr> <tr> <td>Y</td> <td>117.4 mm</td> <td>117.4 mm</td> </tr> <tr> <td>Z</td> <td>156.2 mm</td> <td>156.2 mm</td> </tr> </tbody> </table>  <p>Options Next</p> | Pos. | Actual TP | Needle Guide | X | 44.1 mm | 44.1 mm | Y | 117.4 mm | 117.4 mm | Z | 156.2 mm | 156.2 mm | <p>Teach Modules 15:16</p> <p>Step 15 of 18: Teach Fast Wash 1</p> <p>Press 'Enter' to manually adjust the position or press 'Next'.</p> <table border="1"> <thead> <tr> <th>Pos.</th> <th>Actual TP</th> <th>Needle Guide</th> </tr> </thead> <tbody> <tr> <td>X</td> <td>504.7 mm</td> <td>504.7 mm</td> </tr> <tr> <td>Y</td> <td>144.8 mm</td> <td>144.8 mm</td> </tr> <tr> <td>Z</td> <td>145.1 mm</td> <td>145.1 mm</td> </tr> </tbody> </table>  <p>Options: Check, Teach, Previous, Select Next</p> | Pos. | Actual TP | Needle Guide | X | 504.7 mm | 504.7 mm | Y | 144.8 mm | 144.8 mm | Z | 145.1 mm | 145.1 mm |
| Pos. | Actual TP | Needle Guide | | | | | | | | | | | | | | | | | | | | | | | | | | | | | | | | | | | | |
| X | 44.1 mm | 44.1 mm | | | | | | | | | | | | | | | | | | | | | | | | | | | | | | | | | | | | |
| Y | 117.4 mm | 117.4 mm | | | | | | | | | | | | | | | | | | | | | | | | | | | | | | | | | | | | |
| Z | 156.2 mm | 156.2 mm | | | | | | | | | | | | | | | | | | | | | | | | | | | | | | | | | | | | |
| Pos. | Actual TP | Needle Guide | | | | | | | | | | | | | | | | | | | | | | | | | | | | | | | | | | | | |
| X | 44.1 mm | 44.1 mm | | | | | | | | | | | | | | | | | | | | | | | | | | | | | | | | | | | | |
| Y | 117.4 mm | 117.4 mm | | | | | | | | | | | | | | | | | | | | | | | | | | | | | | | | | | | | |
| Z | 156.2 mm | 156.2 mm | | | | | | | | | | | | | | | | | | | | | | | | | | | | | | | | | | | | |
| Pos. | Actual TP | Needle Guide | | | | | | | | | | | | | | | | | | | | | | | | | | | | | | | | | | | | |
| X | 504.7 mm | 504.7 mm | | | | | | | | | | | | | | | | | | | | | | | | | | | | | | | | | | | | |
| Y | 144.8 mm | 144.8 mm | | | | | | | | | | | | | | | | | | | | | | | | | | | | | | | | | | | | |
| Z | 145.1 mm | 145.1 mm | | | | | | | | | | | | | | | | | | | | | | | | | | | | | | | | | | | | |
| <p>Solvent Reservoir Teaching Position</p> | <p>Wash Vial Teaching Position</p> | <p>Fast Wash Station Teaching Position</p> | | | | | | | | | | | | | | | | | | | | | | | | | | | | | | | | | | | | |
| <p>Teach Modules 15:17</p> <p>Step 16 of 18: Teach Large Wash 1</p> <p>Press 'Enter' to manually adjust the position or press 'Next'.</p> <table border="1"> <thead> <tr> <th>Pos.</th> <th>Actual TP</th> <th>Needle Guide</th> </tr> </thead> <tbody> <tr> <td>X</td> <td>43.9 mm</td> <td>43.9 mm</td> </tr> <tr> <td>Y</td> <td>117.3 mm</td> <td>117.3 mm</td> </tr> <tr> <td>Z</td> <td>156.4 mm</td> <td>156.4 mm</td> </tr> </tbody> </table>  <p>Options Next</p> | Pos. | Actual TP | Needle Guide | X | 43.9 mm | 43.9 mm | Y | 117.3 mm | 117.3 mm | Z | 156.4 mm | 156.4 mm | <p>Teach Modules 15:17</p> <p>Step 17 of 18: Teach Standard Wash 1</p> <p>Press 'Enter' to manually adjust the position or press 'Next'.</p> <table border="1"> <thead> <tr> <th>Pos.</th> <th>Actual TP</th> <th>Needle Guide</th> </tr> </thead> <tbody> <tr> <td>X</td> <td>43.9 mm</td> <td>43.9 mm</td> </tr> <tr> <td>Y</td> <td>117.3 mm</td> <td>117.3 mm</td> </tr> <tr> <td>Z</td> <td>156.4 mm</td> <td>156.4 mm</td> </tr> </tbody> </table>  <p>Options Next</p> | Pos. | Actual TP | Needle Guide | X | 43.9 mm | 43.9 mm | Y | 117.3 mm | 117.3 mm | Z | 156.4 mm | 156.4 mm | <p>Teach Modules 15:17</p> <p>Step 18 of 18: Finish Teaching</p> <p>Press 'Ok' to move the Head back to home position.</p> <p style="text-align: right;">Ok</p> | | | | | | | | | | | | |
| Pos. | Actual TP | Needle Guide | | | | | | | | | | | | | | | | | | | | | | | | | | | | | | | | | | | | |
| X | 43.9 mm | 43.9 mm | | | | | | | | | | | | | | | | | | | | | | | | | | | | | | | | | | | | |
| Y | 117.3 mm | 117.3 mm | | | | | | | | | | | | | | | | | | | | | | | | | | | | | | | | | | | | |
| Z | 156.4 mm | 156.4 mm | | | | | | | | | | | | | | | | | | | | | | | | | | | | | | | | | | | | |
| Pos. | Actual TP | Needle Guide | | | | | | | | | | | | | | | | | | | | | | | | | | | | | | | | | | | | |
| X | 43.9 mm | 43.9 mm | | | | | | | | | | | | | | | | | | | | | | | | | | | | | | | | | | | | |
| Y | 117.3 mm | 117.3 mm | | | | | | | | | | | | | | | | | | | | | | | | | | | | | | | | | | | | |
| Z | 156.4 mm | 156.4 mm | | | | | | | | | | | | | | | | | | | | | | | | | | | | | | | | | | | | |
| <p>Large Wash Station Teaching Position</p> | <p>Standard Wash Station Teaching Position</p> | <p>Teaching Position</p> | | | | | | | | | | | | | | | | | | | | | | | | | | | | | | | | | | | | |

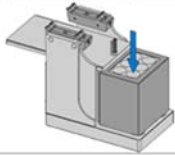
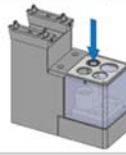
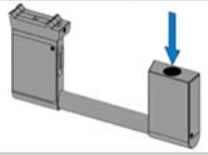
Check Teaching Modules

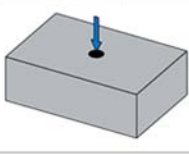
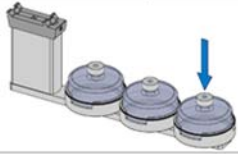
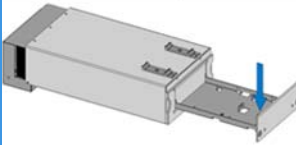
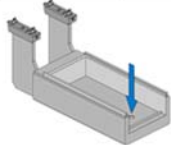
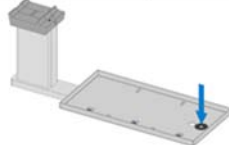
This section shows you how to check and verify the teaching positions of all the modules included into the system.

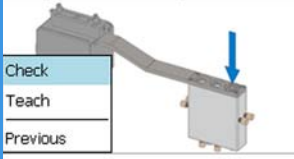
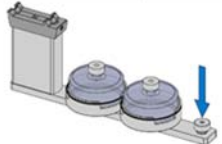
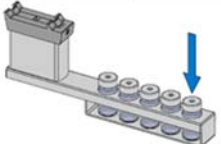
Note In this section a fine tuning is not foreseen. If a fine tuning is necessary, go either go back to the section “Teach Module” on page 141, or from the start screen activate the pull-up menu **Option**, and select **Setup | Modules**.

❖ To check the teaching module

1. Select the wizard item **Check Teaching Modules**. See Figure 96.

Figure 96. Wizard Item Check Teaching Modules

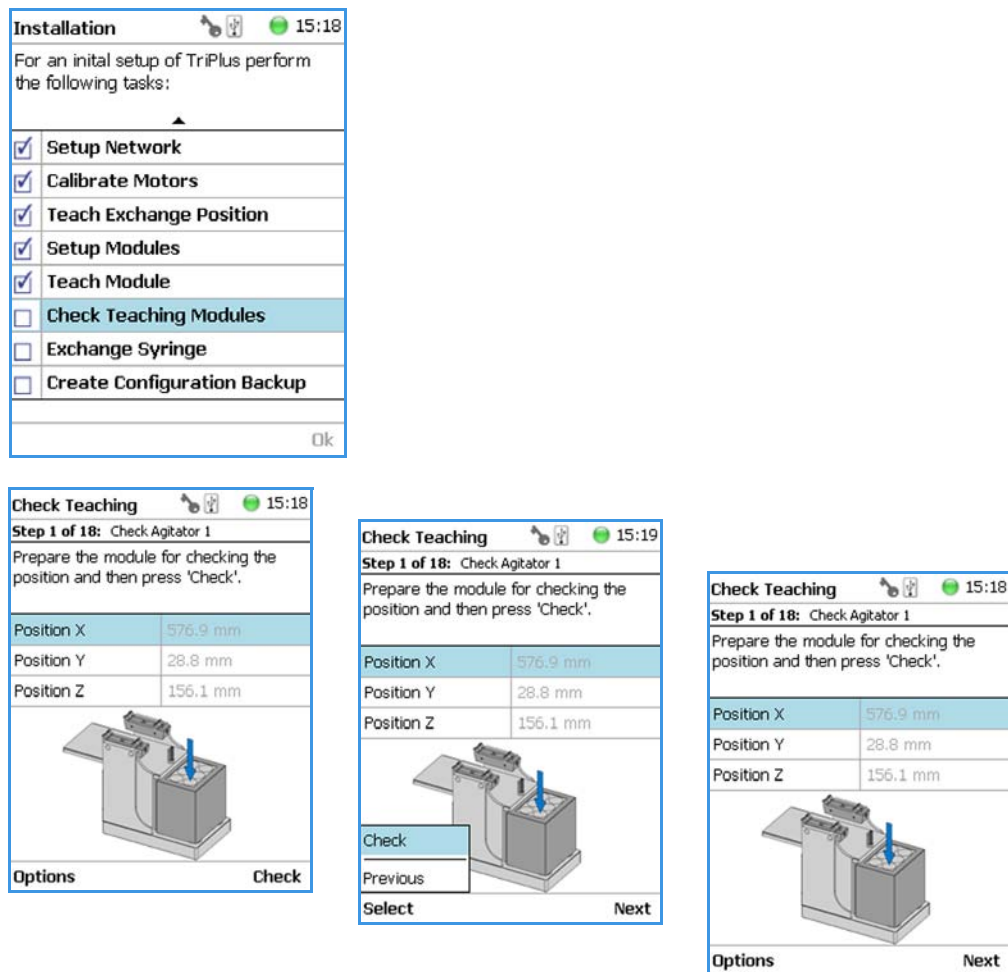

2. Press **Check** to activate the wizard. The Head moves to the first module in the list, positions itself at the Teaching Point, and waits for the next command. This gives the operator the chance to verify the position, and if necessary make some fine tuning and save the new settings.

3. Modules which have no direct access to the teaching point (lunette) such as the Vortexer are treated the same way as it would for a routine run.

Note It is mandatory to insert a vial into the Vortexer to teach the X-,Y-, and Z-Axes positions. If the vial is not inserted, the Z-Axis value could be out of range, resulting in an error.

4. Press **Next** to continue within the wizard; the Head moves to the next module.
5. The pull-up menu **Previous** moves one step back to the previous module and verifies the teaching position again.

Exchange Syringe

This section allow to move the head for replacing the syringe.

❖ To exchange the syringe

1. Select the wizard item **Exchange Syringe**. See [Figure 96](#).

Figure 97. Wizard Item Exchange Syringe

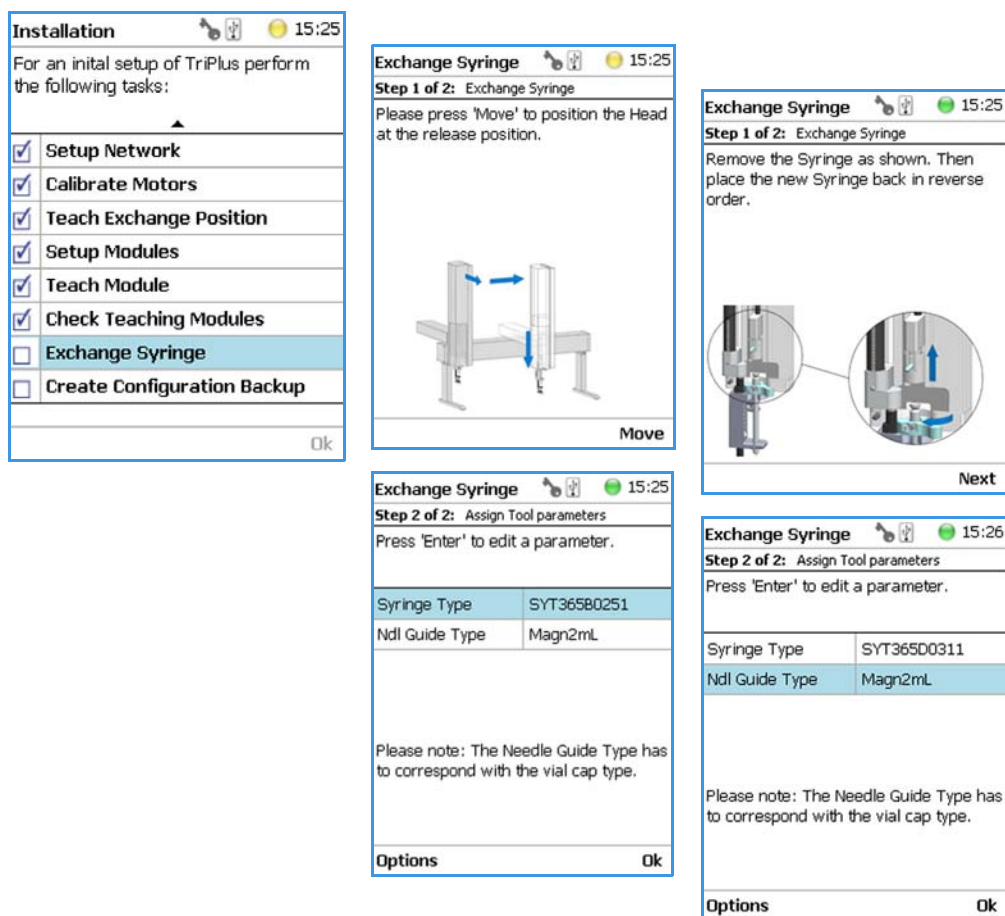

2. Press **Move** to position the head at the release position.
3. Remove the syringe and replace it with a new syringe, then press **Next** to continue.
4. Select **Syringe Type | Option** to choose the type of syringe, then press **Ok**.
5. Select **Ndl Guide Type | Option** to choose the type of needle guide, then press **Ok**.

Create a Configuration Backup File

It is highly recommended to backup the configuration of system after completing the **Installation** wizard.

Backup, Restore, and Updates are explained in chapter **Interfacing the TriPlus 100 Liquid Sampler to Other Devices** in the *TriPlus 100 Liquid Sampler Hardware Manual*.

❖ To create a configuration backup file

1. Select the wizard item **Create Configuration Backup** and follow the dialog. See [Figure 98](#).

Figure 98. Wizard Item Create Configuration Backup File

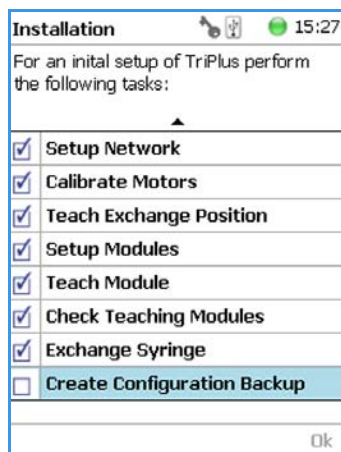

2. The proposed name for the backup file is **After Installation**. The file is tagged with the current date and time. The file name can be changed by the operator.
3. Press the **Enter** button to open the alphanumeric characters or use the pull-up menu **Options** to insert or delete a character, see the examples in [Figure 99](#).

Figure 99. Creating a Backup File

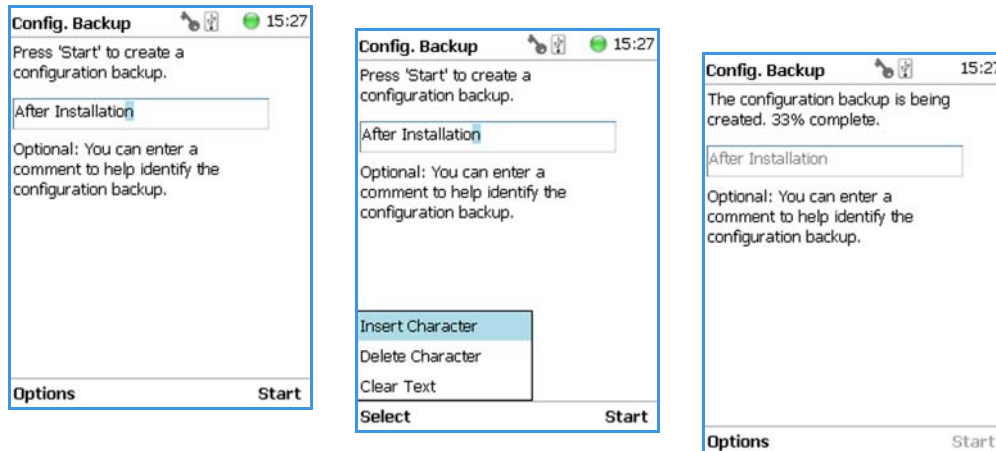

4. After the file name definition, press **Start** to start the process. The blinking light indicates that the process has been executed. The progress of the backup is updated to inform the operator how many percent are completed.
5. This process only takes a few minutes. After completion, press **Exit** to finish the installation wizard.

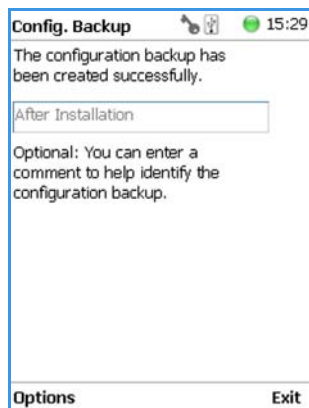

Note The Backup file is stored in the SD card, which is installed on the control board.

This file can be saved on the USB Stick, see “[Setup Menu Item](#)” on [page 55](#).

The file can also be used to make a Restore of the Firmware. Please note this option is only available with access level rights for the Extended User.

Create New Tray System Item

Selecting the menu item **Create New Tray System** enables you to define a combined system of a Tray Holder, Tray Type, and Vial Type. This task is mainly used if a custom specific Tray Holder will be used.

❖ **To create a new tray system**

1. Select the menu item **Create New Tray System**. See [Figure 100](#).

Figure 100. Selecting Menu Item Create New Tray System

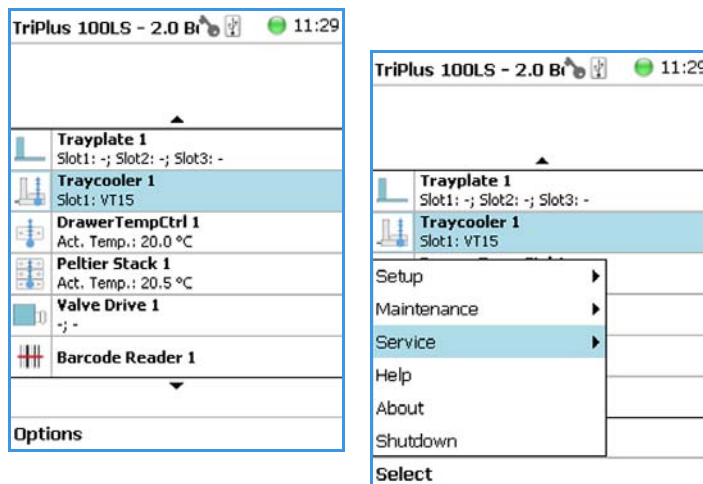

2. By opening the individual list items pre-selected parameters are available for use. See [Figure 101](#).

Figure 101. Tray Holder Choices

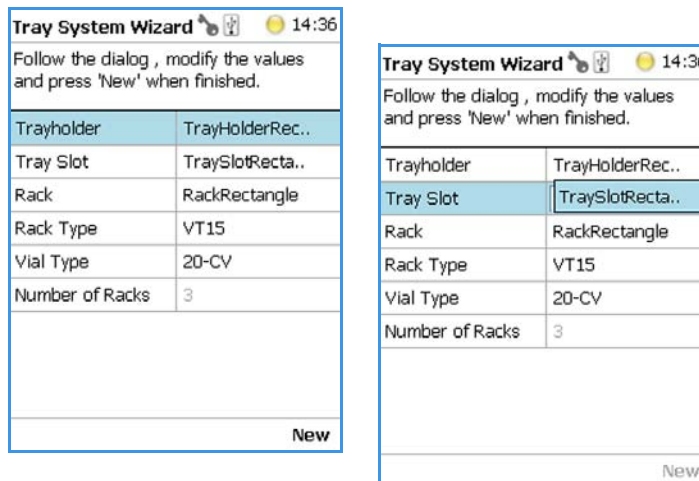

Note The Tray can be either a Tray or a Well Plate. Accordingly, the choices are preselected for Tray Type or a Well Plate Type.

3. Press **New** for creating the newly-defined Tray System, which is a complete setup of Tray Holder, Tray, Tray Type, and Vial Type.
4. The wizard closes, and the software returns to the Start Screen.

[Table 68](#) lists the create New Tray Type parameters.

Table 68. Create New Tray Type Parameters

| Item | Description |
|-----------------|---|
| Tray Holder | Tray Holder Liquid Holder (passive module). |
| Tray Slot | Tray Slot, currently the only supported type. |
| Tray | Tray, currently the only supported type. |
| Tray Type | Tray 15, Tray 54, Tray 32, Tray 60, Tray 70 See “Definition of Terms, Naming Conventions, and Start Screen Icons” on page 2 for details. |
| Vial Type | 1-CV, 2-CV, 10-CV, 20-CV Regular Vials. 2-SR, 10-SR. Vials combined with corresponding adapter, reservoir. |
| Number of Trays | Defines the numbers of sample trays that can be placed in the Tray Holder. |

Analytical Troubleshooting

This chapter gives a quick overview of possible causes and recommended actions which can be taken to eliminate an erratic behavior.

Contents

- [General Points Regarding Chromatographic Effects](#)

This guide does not replace the troubleshooting guides for chromatographic techniques.

General Points Regarding Chromatographic Effects

This sections provides general troubleshooting guidelines regarding the chromatographic effects:

Table 69. General Points Regarding GC Effects - Troubleshooting Guideline (Sheet 1 of 3)

| Symptom or Error Message | Possible Cause | Recommended Action |
|---|---|--|
| Very low or no detector signal is observed. | Clogged syringe. | Remove syringe and aspirate/dispense liquid manually. Clean syringe. |
| | Bent syringe needle or bent plunger. | Inspect the syringe. Replace it if necessary Note: Bottom Sensing using a long needle (85 mm) has a high risk of needle bending. How to remove a syringe with a bent needle or plunger is explained in the section Manually Removing a TriPlus 100 Liquid Sampler Tool from the LS Head of the <i>TriPlus 100 Liquid Sampler Hardware Manual</i> . |
| | No sample liquid is injected. | Check, adjust, the needle penetration into sample vial. |
| | Sample volume too low. | Increase sample volume. |
| | Wrong setting of syringe needle penetration in GC injector. | Check Ndl Penetration Depth settings and compare with GC manufacturer recommended parameters. |
| Syringe does not fill properly. | Air bubbles below syringe plunger. It is possible that air bubbles remain below the plunger after the first pull-up. If the plunger is moved up and down several times, these air bubbles are worked out. | Increase method parameter Fill strokes. Check the method parameters Fill Speed and Pull-up Delay. |
| | Wrong type of syringe assigned to tool holder. | Check the syringe parameters to ensure that the correct syringe type is assigned to the tool holder. Verify the scale length parameter. |
| | Syringe needle penetration depth in vial incorrect. | Check the syringe needle penetration depth in the sample vial. |
| | Syringe plunger polymer tip worn out. | Manually check the tightness of the polymer plunger tip. When in doubt, replace the plunger. |
| | Glass barrel cracked. | Check the integrity of the syringe. When in doubt, replace the syringe. |

Table 69. General Points Regarding GC Effects - Troubleshooting Guideline (Sheet 2 of 3)

| Symptom or Error Message | Possible Cause | Recommended Action |
|--|--|--|
| Sample peaks/responses are not reproducible. | Dirty syringe. | Increase Pst Cln Slv1/Slv2 values in method. Use PreCln Slv1/Slv2 and Pre Cln Spl. |
| | Syringe pressure difference. | Increase Pull-up Delay value. |
| | Vacuum created in sample vial. | Reduce Sample volume in sample vial. Use Pre Pressure Vial mode. |
| | Highly volatile solvent. | Use gas-tight syringe and sample tray cooling. |
| | Improperly crimped vials. | Check vial cap by attempting to rotate by hand. Loose caps might cause selective loss of volatile compounds from the sample. Adjust crimping tool correctly. |
| | Method Parameters. | Check recommended Method Parameters. The following parameters are crucial and must be verified first: <ul style="list-style-type: none"> • Def Aspirate Flow Rate (Fill Speed) • Def Aspirate Delay (Pull-up Delay) • Def Dispense Flow Rate (Injection speed) • Def Dispense Delay (Post Inj Delay) <p>Note that for dedicated cycles, certain parameters are locked.</p> |
| Excessive carryover between samples. | Dirty syringe. | Increase Pst Inj Slv1/2 values in method. Use PreClnSlv1/Slv2 and PrClnSpl. Check and, if necessary, replace vial septa from Wash/Waste vials. |
| | Inappropriate wash solvent. | Use appropriate wash solvent. |
| | Wash Solvent and Waste vial septa too tight. | Check if the syringe fills completely when washing. If several cleaning cycles are programmed and many samples are processed, then vacuum in the Wash Solvent vials and overpressure in the Waste vials might build up. Cut away a segment of the solvent and Waste septa to ensure equalization of pressure. |
| | Wash solvent level too low. | Check the solvent volume in the Wash Vial and the syringe needle penetration in the vial. |
| | Solvent level in Waste vial too high. | Check the volume of the solvent in the Waste Vial. Check also the needle penetration into the waste vial. The needle must not touch the liquid at all. |

6 Analytical Troubleshooting

General Points Regarding Chromatographic Effects

Table 69. General Points Regarding GC Effects - Troubleshooting Guideline (Sheet 3 of 3)

| Symptom or Error Message | Possible Cause | Recommended Action |
|--------------------------------------|--|---|
| Unexplained collisions of Head. | Object not defined correctly. | Define Object correctly. See Chapter 5 “TriPlus 100 Liquid Sampler Defining Object Positions” in the <i>TriPlus 100 Liquid Sampler Hardware Manual</i> . Verify the position for all objects, including passive and active modules. |
| Unexpected collision on Tray Holder. | Wrong Vial Type settings in Tray Type. | Check the settings in Tray Type. |