

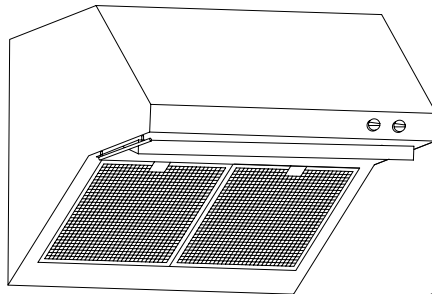

GE Consumer Products

TECHNICAL SERVICE GUIDE

2003 Monogram 30-, 36-, and 48 in. Stainless Steel Hoods

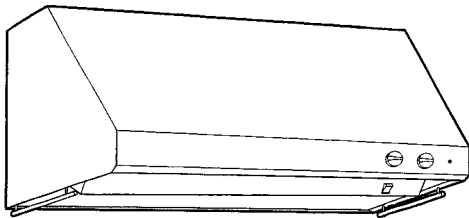

MODEL SERIES:

ZV30RS
ZV30SS
ZV30TS
ZV36RS
ZV36SS
ZV36TS
ZV48RS
ZV48SS
ZV48TS

Technical Consultant:
Tom Ledbetter
Cincinnati Zone

PUB # 31-9107 08/03





IMPORTANT SAFETY NOTICE

The information in this service guide is intended for use by individuals possessing adequate backgrounds of electrical, electronic, and mechanical experience. Any attempt to repair a major appliance may result in personal injury and property damage. The manufacturer or seller cannot be responsible for the interpretation of this information, nor can it assume any liability in connection with its use.

WARNING

To avoid personal injury, disconnect power before servicing this product. If electrical power is required for diagnosis or test purposes, disconnect the power immediately after performing the necessary checks.

RECONNECT ALL GROUNDING DEVICES

If grounding wires, screws, straps, clips, nuts, or washers used to complete a path to ground are removed for service, they must be returned to their original position and properly fastened.

GE Consumer Products

Technical Service Guide

Copyright © 2003

All rights reserved. This service guide may not be reproduced in whole or in part in any form without written permission from the General Electric Company.

Table of Contents

Autotransformer - ZV30, ZV36, and ZV48.....	10
Autotransformer - ZV30R, ZV36R, and ZV48R	15
Baffle Grease Filter and Drip Trays - ZV30, ZV36, and ZV48	7
Control Features	6
Data Location	4
Fan Motor - ZV30, ZV36, and ZV48	7
Fan Motor - ZV30R, ZV36R, and ZV48R	12
Fan Motor Indicator Light - ZV30, ZV36, and ZV48	11
Fan Motor Indicator Light - ZV30R, ZV36R, and ZV48R	15
Grease Baffles - ZV30R, ZV36R, and ZV48R	12
Heat Lamp Panel - ZV30, ZV36, and ZV48	7
Heat Lamp Panel - ZV30R, ZV36R, and ZV48R	12
Heat Lamp Socket - ZV30, ZV36, and ZV48	8
Heat Lamp Socket - ZV30R, ZV36R, and ZV48R	12
Heat Lamp Switch - ZV30, ZV36, and ZV48	8
Heat Lamp Switch - ZV30R, ZV36R, and ZV48R	13
Introduction	4
Nomenclature	4
Illustrated Parts	21
Rotary Switch - ZV30, ZV36, and ZV48	10
Rotary Switch - ZV30R, ZV36R, and ZV48R	14
Schematics	19
Surface Lights - ZV30, ZV36, and ZV48	9
Surface Lights - ZV30R, ZV36R, and ZV48R	13
Surface Light Sockets - ZV30, ZV36, and ZV48	9
Surface Light Sockets - ZV30R, ZV36R, and ZV48R	14
Troubleshooting	16
Warranty	5

Introduction

The 2003 Monogram Stainless Steel, 30-, 36- and 48 in. Range Hood models are being introduced with a new motor mount that allows for easy removal and replacement of the fan motor.

Other features include:

- Baffle grease filters and drip trays to allow for quick and easy cleaning.
- A four-setting light control.
- A four-setting fan control.
- An infrared heat lamp.
- A fan ON indicator light.
- Kitchen utensil rods, located on each side of the hood used to hang and display cooking utensils, pots and pans, or nonflammable decorative items.

Model ZV30

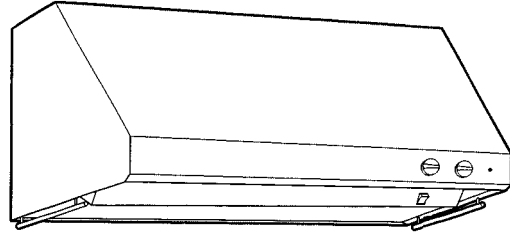

Model ZV30R

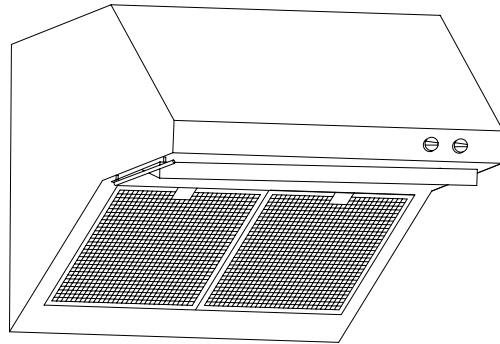

Nomenclature

To access the nomenclature and schematic diagram, remove the left grease baffle.

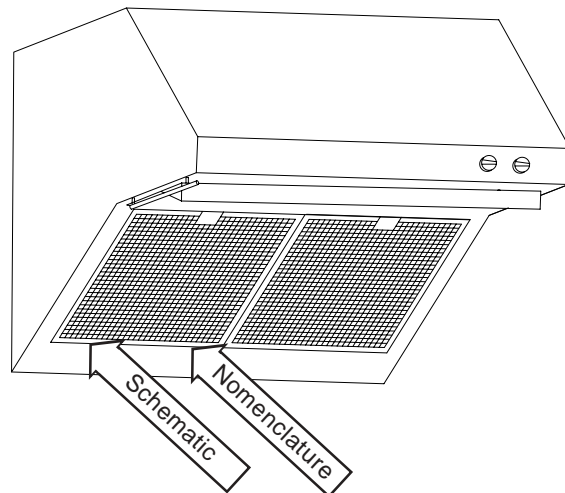
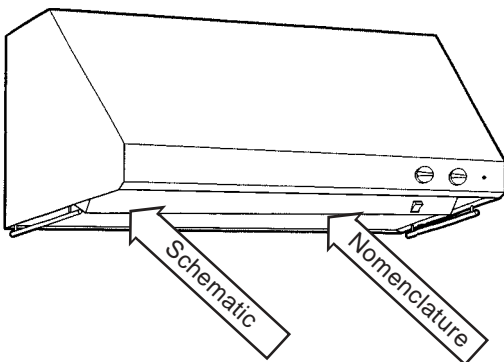

Warranty

Monogram Hood Warranty

Proof of original purchase date is needed to obtain service under warranty.

What Is Covered

Full One-Year Warranty

For one year from date of original purchase, we will provide, free of charge, parts and service labor in your home to repair or replace **any part of the hood** that fails because of a manufacturing defect.

This warranty is extended to the original purchaser and any succeeding owner for products purchased for ordinary home use in the mainland 48 states, Hawaii, and Washington, D.C. In Alaska, the warranty is the same except that it is LIMITED because you must pay to ship the product to the service shop or for the service technician's travel costs to your home.

All warranty service will be provided by our Factory Service Centers or by our authorized Customer Care[®] Servicers during normal working hours.

Should your appliance need service, during warranty period or beyond, call 800.444.1845.

What Is Not Covered

- Service trips to your home to teach you how to use the product.
- Replacement of home fuses or resetting of circuit breakers.
- Incidental or consequential damage caused by possible defects with this appliance.
- Replacement of the filters and light bulbs.
- Damage to the product caused by accident, fire, floods, or acts of God.
- Failure of the product if it is used for other than its intended purpose or used commercially.
- Improper installation.

If you have an installation problem, contact your dealer or installer. You are responsible for providing adequate electrical, gas, exhausting, and other connecting facilities as described in the Installation Instructions provided with the product.

Some states do not allow the exclusion or limitation of incidental or consequential damages, so the above limitation or exclusion may not apply to you. This warranty gives you specific legal rights, and you may also have other rights which vary from state to state.

To know what your legal rights are in your state, consult your local or state consumer affairs office or your state's Attorney General.

Warrantor: General Electrical Company. Louisville, KY 40225

Control Features

1 - Light Control

The two surface lights are controlled using a 5-position switch (OFF, 1, 2, 3, and HI). Turn the light from OFF to HI to adjust the intensity of the light while cooking.

2 - Fan Control

The fan speed is controlled using a 5-position switch (OFF, 1, 2, 3, and HI). Turn the fan control speed from OFF to HI as needed.

3 - Fan Indicator Light

The fan indicator light comes ON when the fan is turned ON.

4 - Heat Lamp Control

The heat lamp is controlled by its own ON/OFF rocker switch. Press the rocker switch for the warming lamps to begin heating.

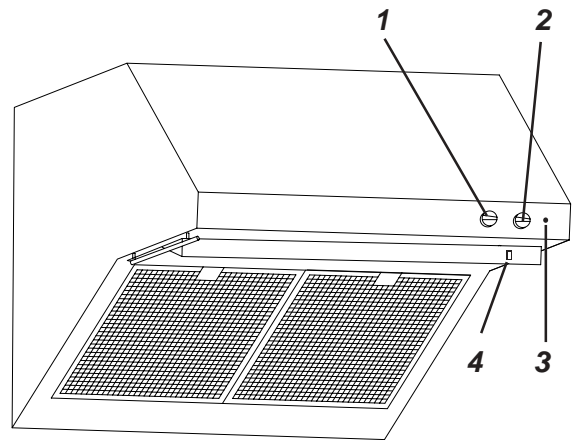
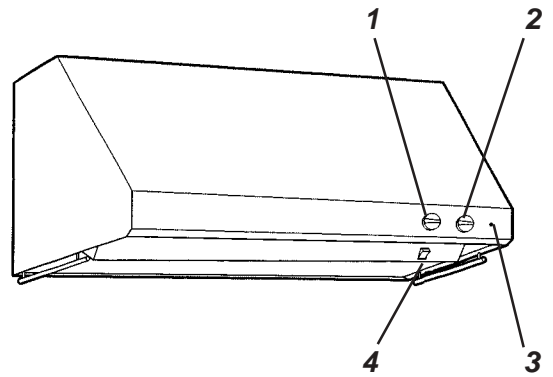

ZV30, ZV36, and ZV48 Components

Baffle Grease Filter and Drip Trays

Removal and Replacement

1. Grasp the 2 handle knobs. Slide the grease filter forward and up until it clears the drip tray and remove. Remove the drip trays.

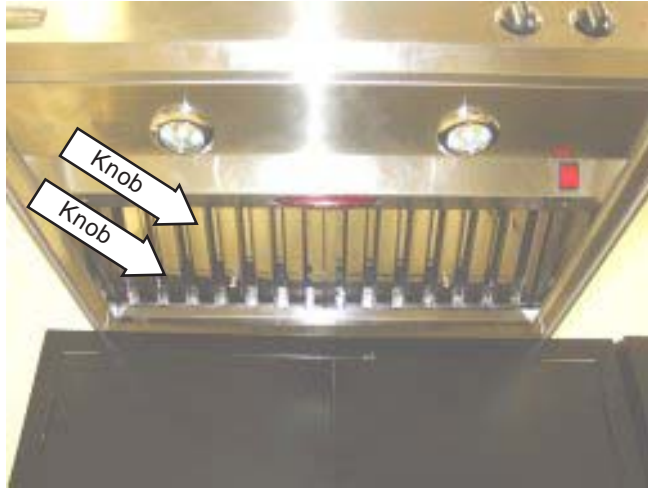

2. Remove the 2 drip trays from drip tray channel.

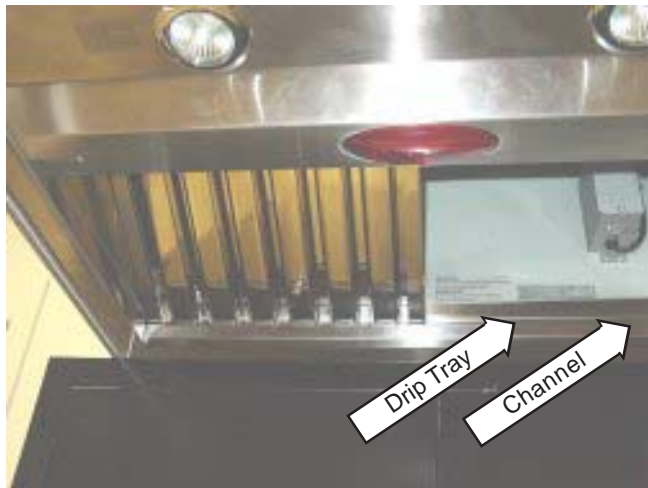

Fan Motor

Removal and Replacement

1. Disconnect the electrical connector from the fan motor.
2. Press back the motor mount retaining clip.
3. Slide the motor mount from the channel and remove the fan motor.

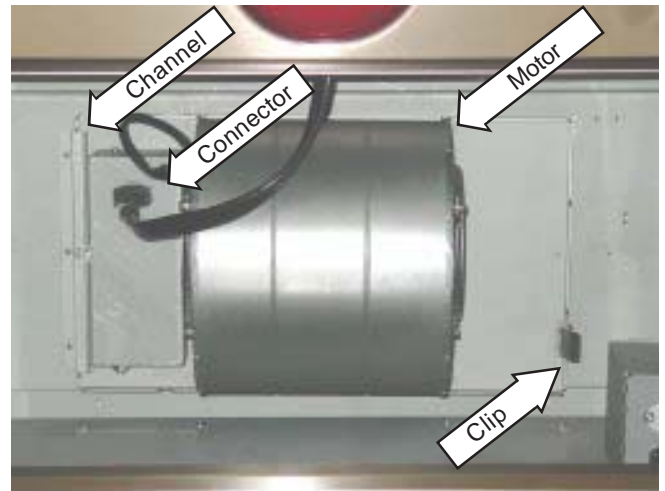

Heat Lamp Panel

Removal and Replacement

WARNING: Heat lamp may be hot.

The bulb is a 120 volt, 175 watt, par-38 infrared bulb. Part No. - WB08X10029.

1. Remove the heat lamp.
2. Remove the 2 screws from the heat lamp panel, then lower the panel from the range hood.

(Continued next page)

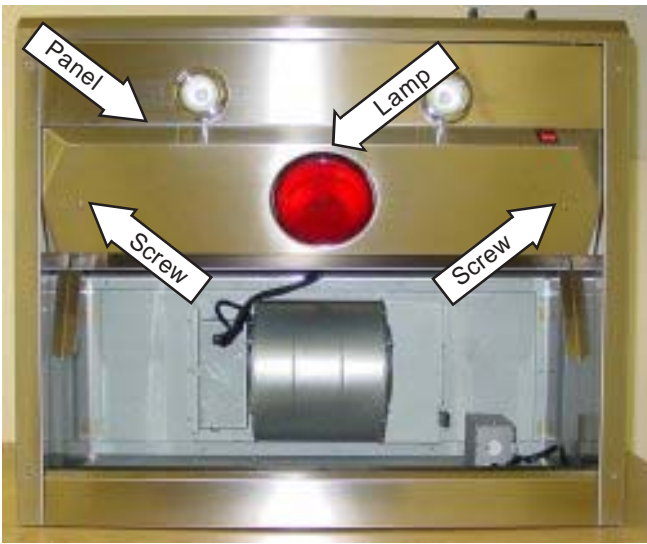

3. Disconnect the electrical connector and remove the heat lamp panel.

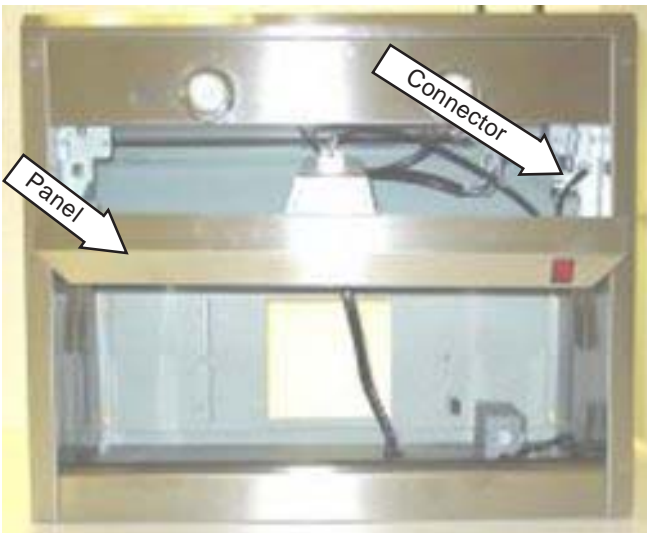

Heat Lamp Socket

Removal and Replacement

WARNING: Heat lamp socket may be hot.

Tech Tip: Use of a plastic putty knife or a taped metal putty knife helps prevent scratching of metal surfaces.

1. Remove the **Heat Lamp Panel**.
2. Press the socket clamps in and pull the heat lamp socket from the heat lamp panel.



3. Loosen the 2 wire retaining screws and remove the wires from the heat lamp socket.



Heat Lamp Switch

Removal and Replacement

1. Remove the **Heat Lamp Panel**.
2. Press the switch clamps in and pull the switch from the heat lamp panel.

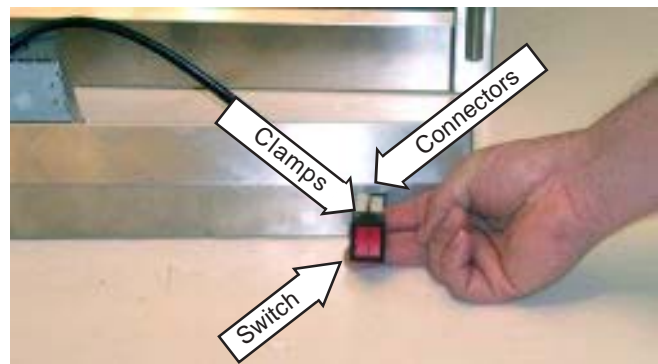

3. Label and disconnect the 4 electrical connectors from the heat lamp switch.

Surface Lights

Removal and Replacement

WARNING: Surface lights may be hot.

The surface lights are 120 volt, 50 watt, par-16 halogen flood bulbs. Part No. WB08X10028.

1. Turn the trim ring counterclockwise until it falls from the socket.
2. Remove the light from the socket.

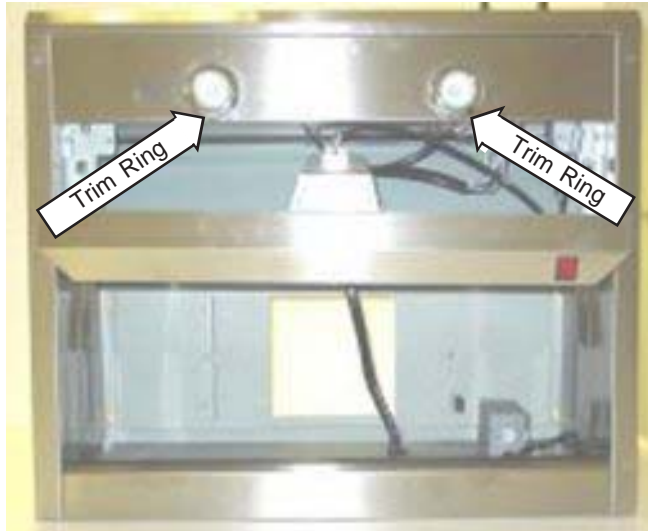

4. Loosen the 2 wire retaining screws and remove the wires from the surface light socket.

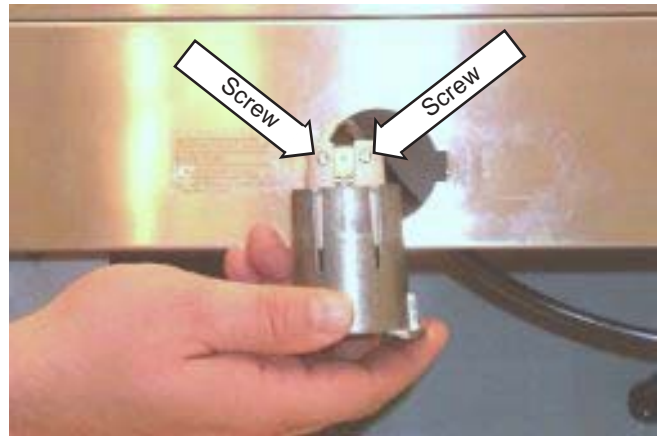

Surface Light Sockets

Removal and Replacement

1. Remove the **Heat Lamp Panel**.
2. Remove the **Surface Lights**.
3. Press the socket clamps in and pull the socket from the overhead light panel.



Rotary Switch

Removal and Replacement

Note: The procedure to remove both the fan rotary switch and the light rotary switch are identical.

1. Remove the **Heat Lamp Panel**.
2. Pull the control knob from the rotary switch.
3. Remove the nut from the front of the rotary switch

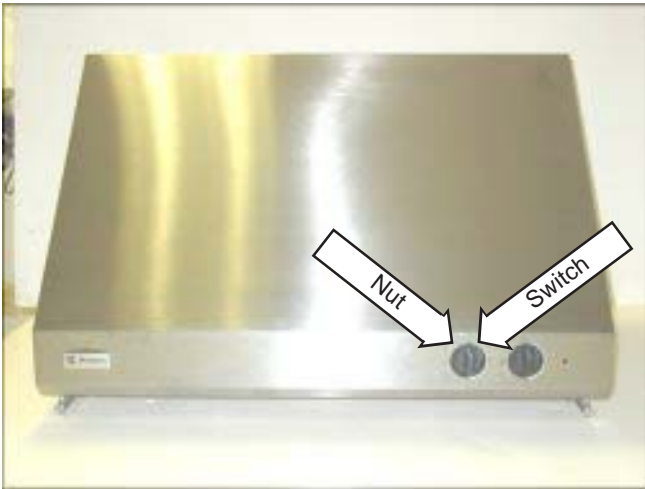

4. Reach behind the hood and pull the rotary switch out to access the electrical connectors.
5. Label and disconnect the 7 wires from the rotary switch and remove the rotary switch.



Note: Make sure the pin on the rotary switch is aligned with the hole in the panel before installing the nut.



Autotransformer

Removal and Replacement

1. Remove the **Heat Lamp Panel**.
2. Remove the light switch control knob. (See **Rotary Switch**.)
3. Remove the fan switch control knob. (See **Rotary Switch**.)
4. Remove the 7 screws that hold the surface light panel to the hood.

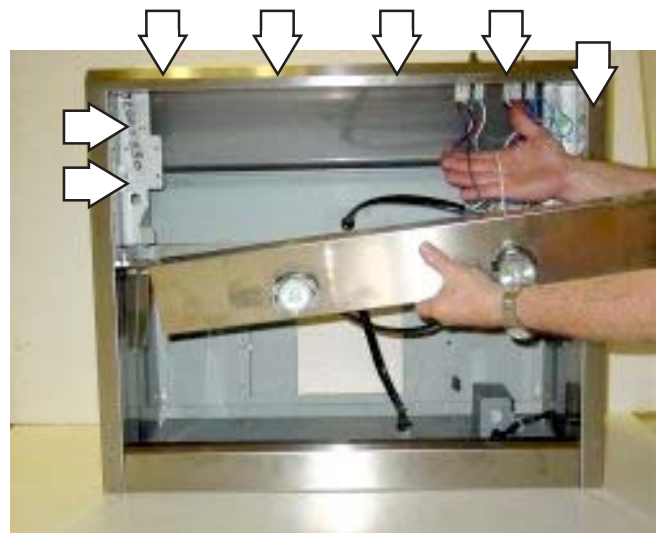

5. Remove the 4 screws that hold the autotransformer to the mounting bracket.

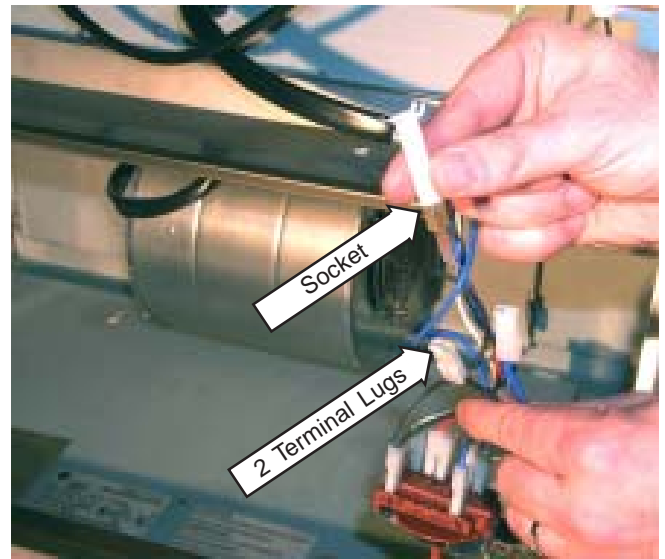
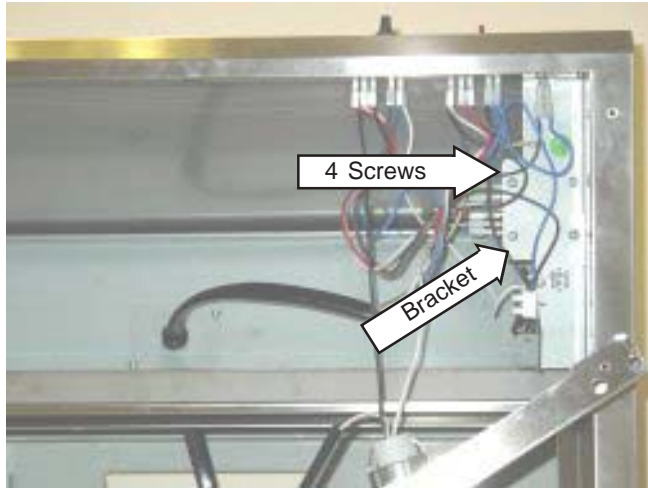

6. Label and disconnect the 7 wires from the autotransformer and remove the autotransformer.

3. Pull the indicator light socket from the red indicator cap.



Fan Motor Indicator Light

Removal and Replacement

1. Remove the *Heat Lamp Panel*.
2. Reach behind the hood and disconnect the 2 wires from the indicator light socket.

ZV30R, ZV36R, and ZV48R Components

Grease Baffles

Removal and Replacement

1. Lift the tabs to release the baffles.
2. Remove the 2 baffles from the hood.



Fan Motor

Removal and Replacement

WARNING: Heat lamp may be hot.

1. Disconnect the electrical connector from the fan motor.
2. Press back the motor mount retaining clip.
3. Slide the motor mount from the channel and remove the fan motor.

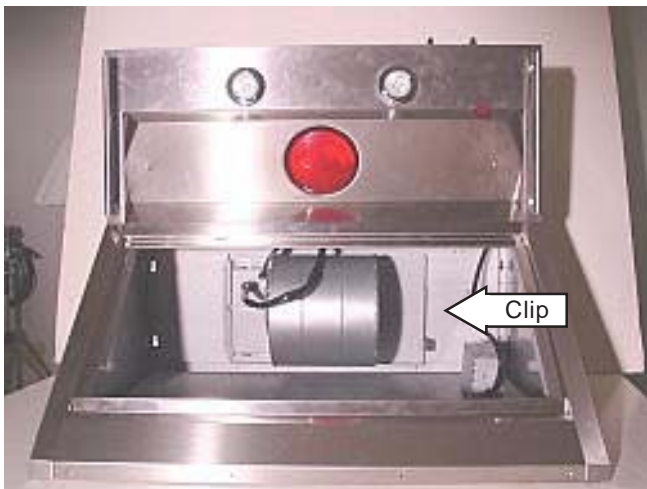

Heat Lamp Panel

Removal and Replacement

WARNING: Heat lamp may be hot.

1. Remove the heat lamp.
2. Remove the 2 screws from the heat lamp panel and lower the heat lamp panel from the range hood.



3. Disconnect the electrical connector and remove the heat lamp panel.



Heat Lamp Socket

Removal and Replacement

WARNING: Heat lamp socket may be hot.

1. Remove the **Heat Lamp Panel**.
2. Press the socket clamps in and pull the heat lamp socket from the heat lamp panel.

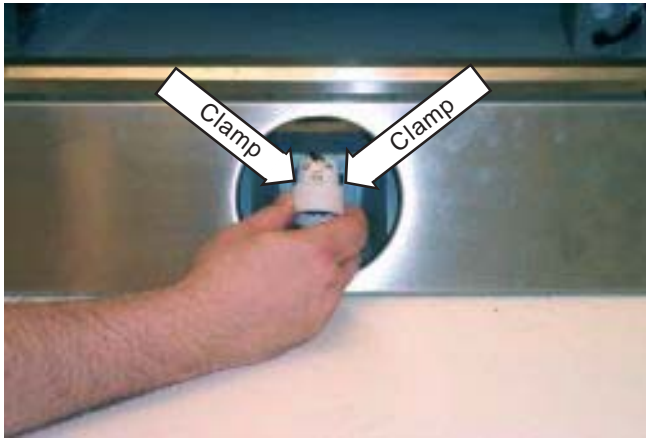

3. Loosen the 2 wire retaining screws and remove the wires from the heat lamp socket.



Heat Lamp Switch

Removal and Replacement

1. Remove the *Heat Lamp Panel*.
2. Press the switch clamps in and pull the switch from the heat lamp panel.
3. Label and disconnect the 4 electrical connectors from the heat lamp switch.

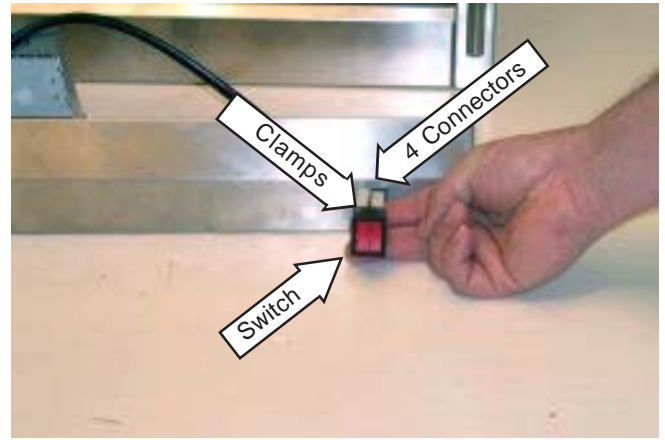

Surface Lights

Removal and Replacement

WARNING: Surface lights may be hot.

1. Turn the trim ring counterclockwise until it falls from the socket.
2. Remove the light from the socket.

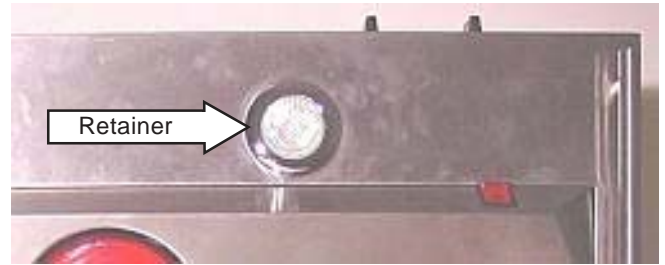

Surface Light Sockets

Removal and Replacement

1. Remove the *Heat Lamp Panel*.
2. Remove the surface lights.
3. Press the socket clamps in and pull the socket from the surface light panel.



4. Loosen the 2 wire retaining screws and remove the wires from the overhead light socket.

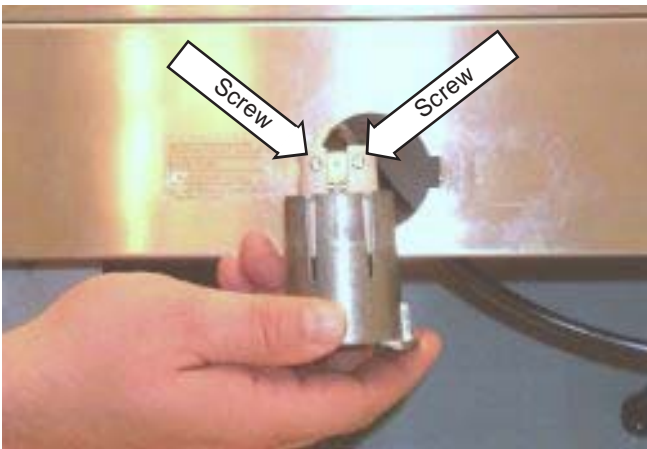

Rotary Switch

Removal and Replacement

Note: The procedure to remove both the fan rotary switch and the light rotary switch are identical.

1. Remove the *Heat Lamp Panel*.
2. Pull the control knob off the rotary switch.
3. Remove the nut from the front of the rotary switch.

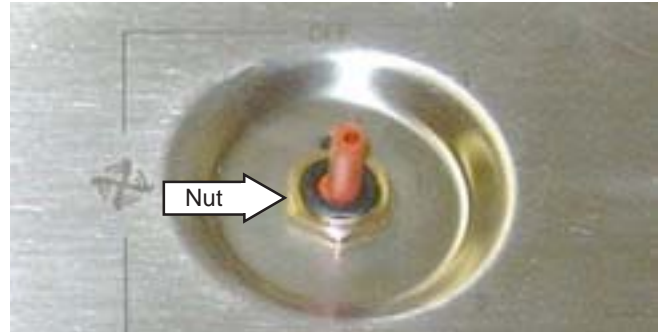

4. Reach behind the hood and pull the rotary switch out to access the electrical connectors.
5. Label and disconnect the 7 terminal lugs from the rotary switch and remove the rotary switch.

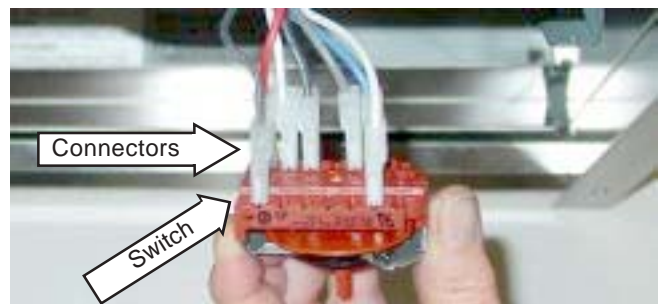

6. Label and disconnect seven terminal lugs from the rotary switch.

Note: Make sure the pin on the rotary switch is aligned with the hole in the panel before installing the nut.

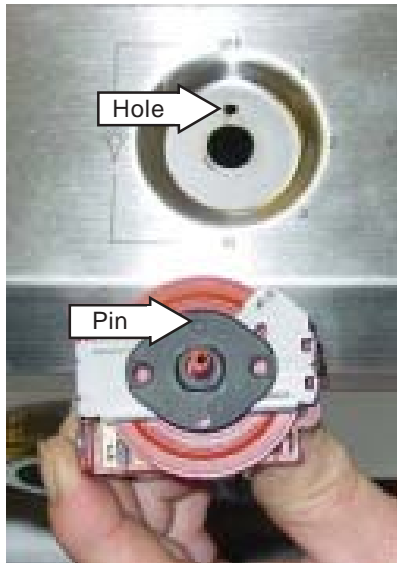

Autotransformer

Removal and Replacement

1. Remove the **Heat Lamp Panel**.
2. Remove the light switch control knob. (See **Rotary Switch**.)
3. Remove the fan switch control knob. (See **Rotary Switch**.)
4. Remove four screws from the autotransformer.
5. Label and disconnect seven terminal lugs from the autotransformer.

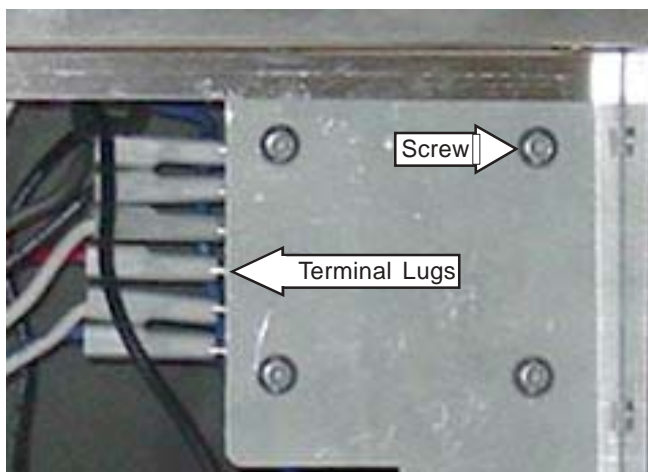

Fan Motor Indicator Light

Removal and Replacement

1. Remove the **Heat Lamp Panel**.
2. Reach behind the hood and disconnect the 2 wires from the indicator light socket.

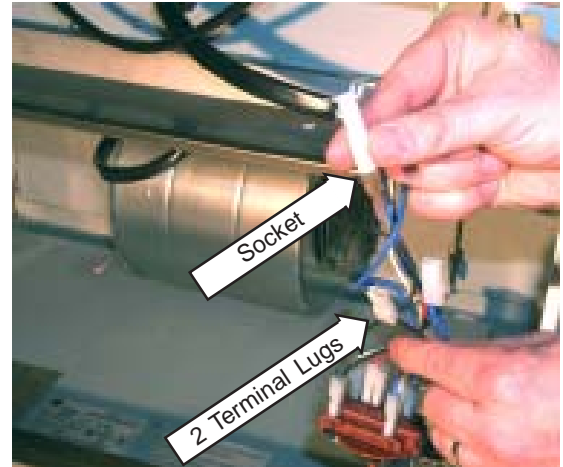

3. Pull the indicator light socket from the red indicator cap.

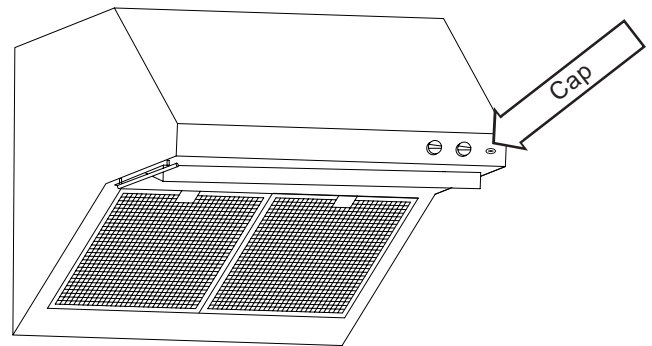

Troubleshooting

Single Fan Motor (Use schematic SE1ANB)

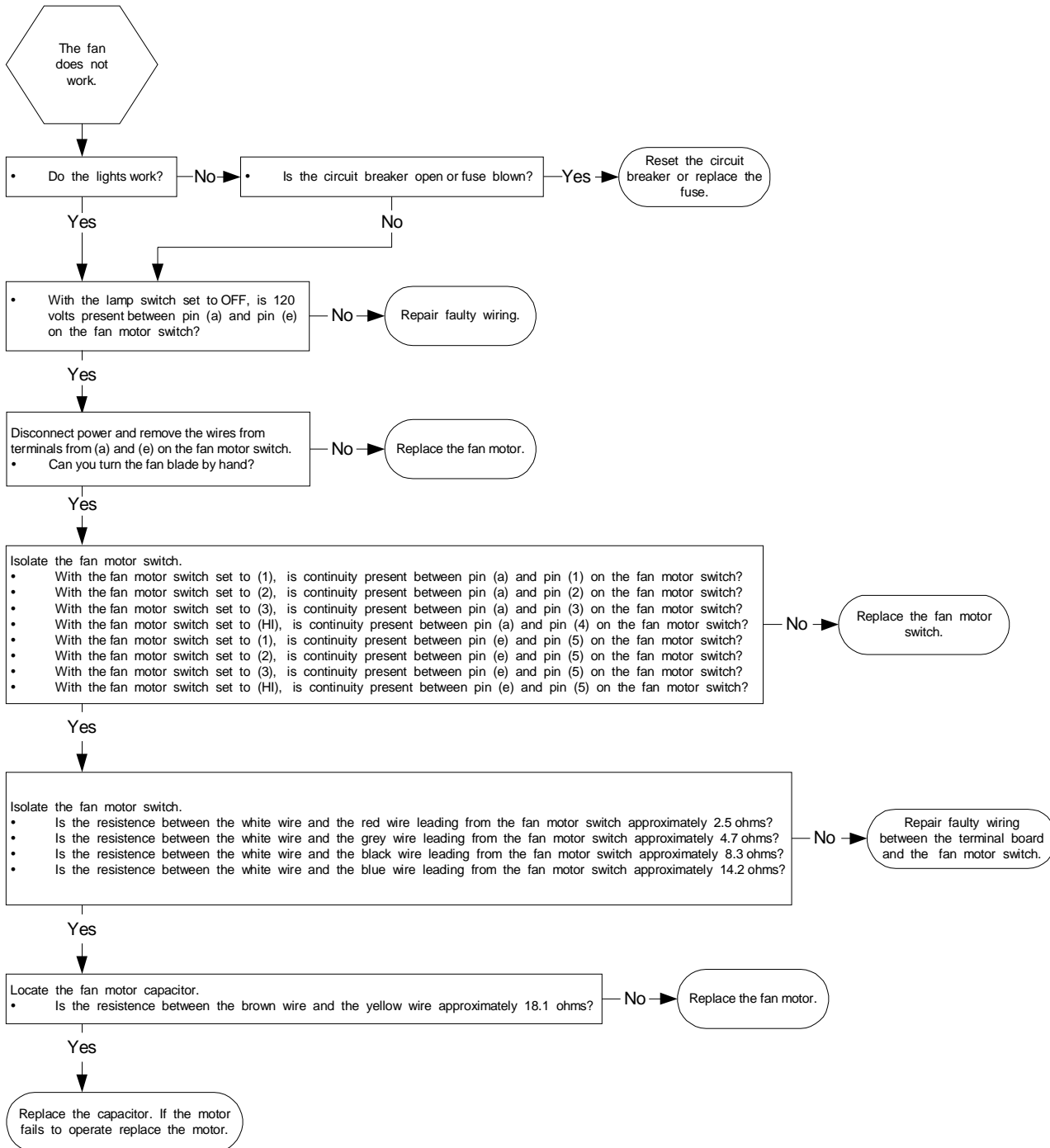

Note: On dual motor models, if one of the capacitors is open, or if the wires and/or connections to the capacitor are open, the motors will run slower than normal. If both capacitors are open, then both motors will hum.

Fan Motor Indicator Light

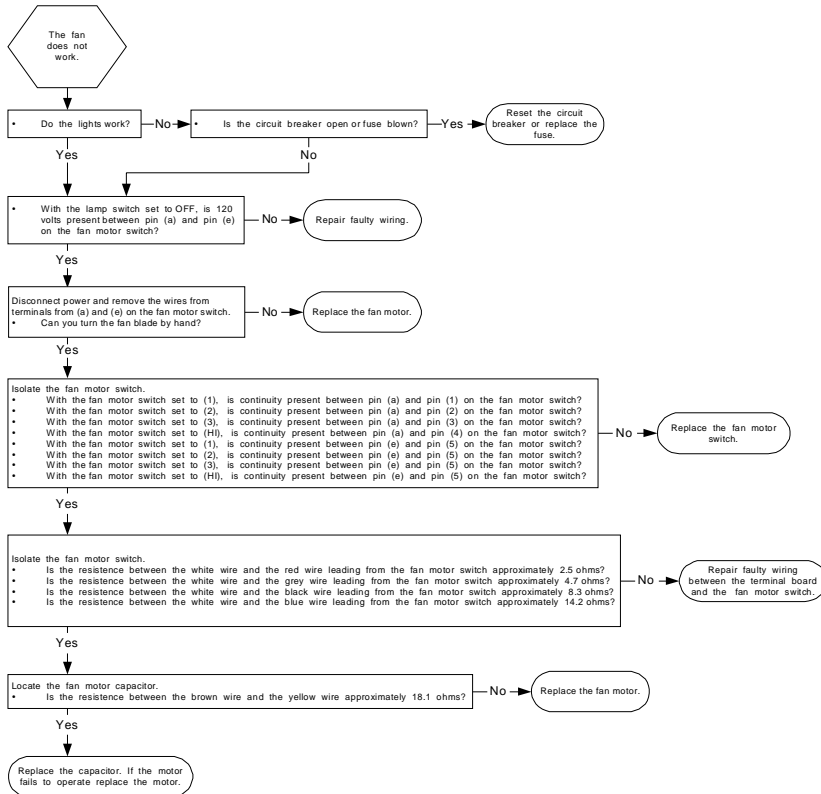

Heat Lamp

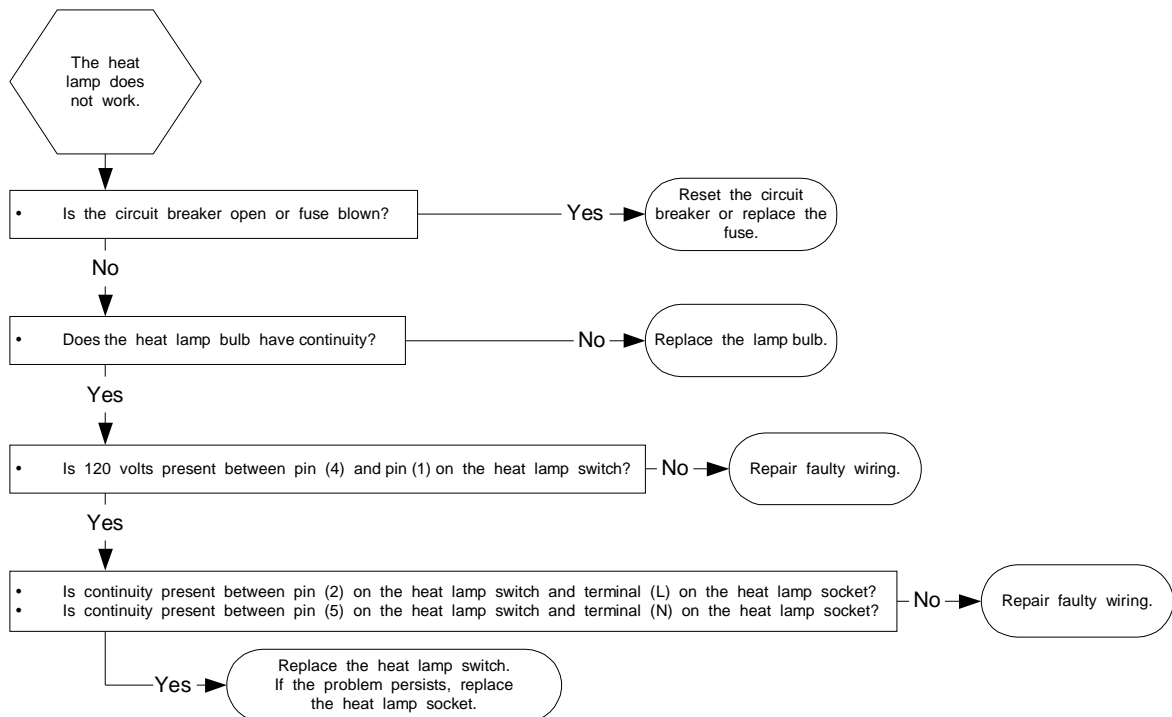

Surface Lights

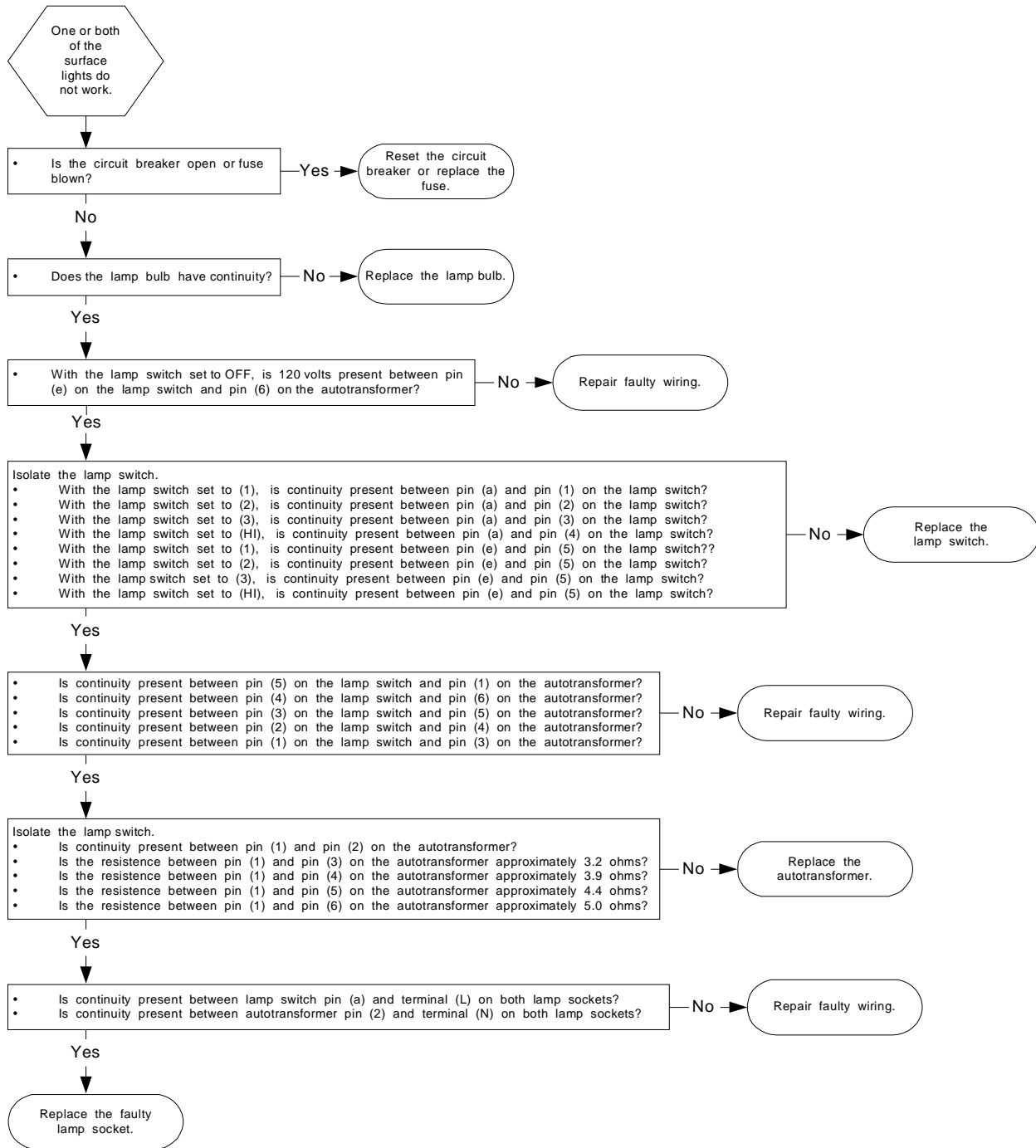

Schematics

All ZV30 and ZV36 - RSF1SS, SSF1SS, and TSF1SS Models

WARNING: Power **must** be disconnected before servicing the appliance.

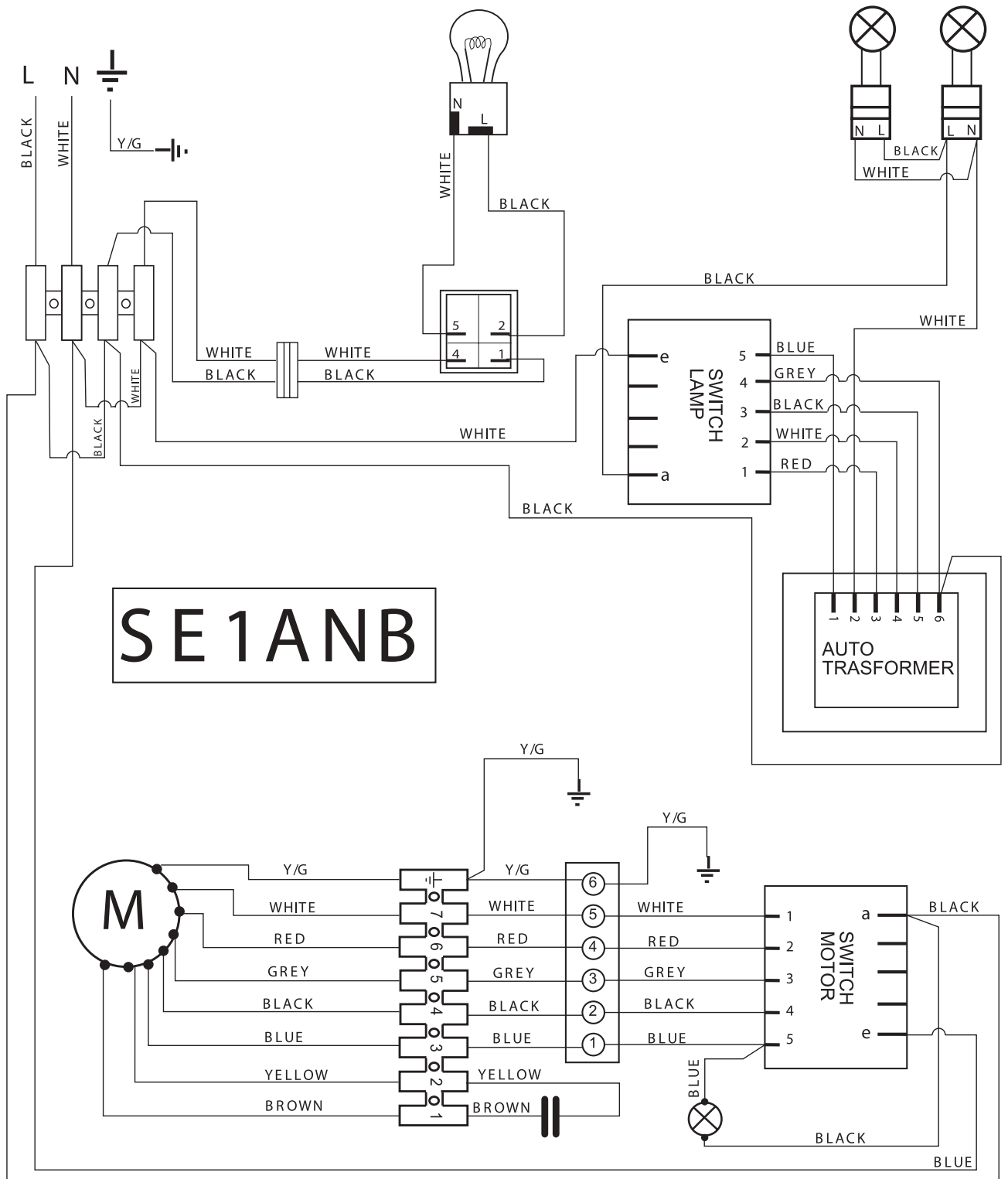

All ZV48 - RSF1SS, SSF1SS, and TSF1SS Models

WARNING: Power **must** be disconnected before servicing the appliance.

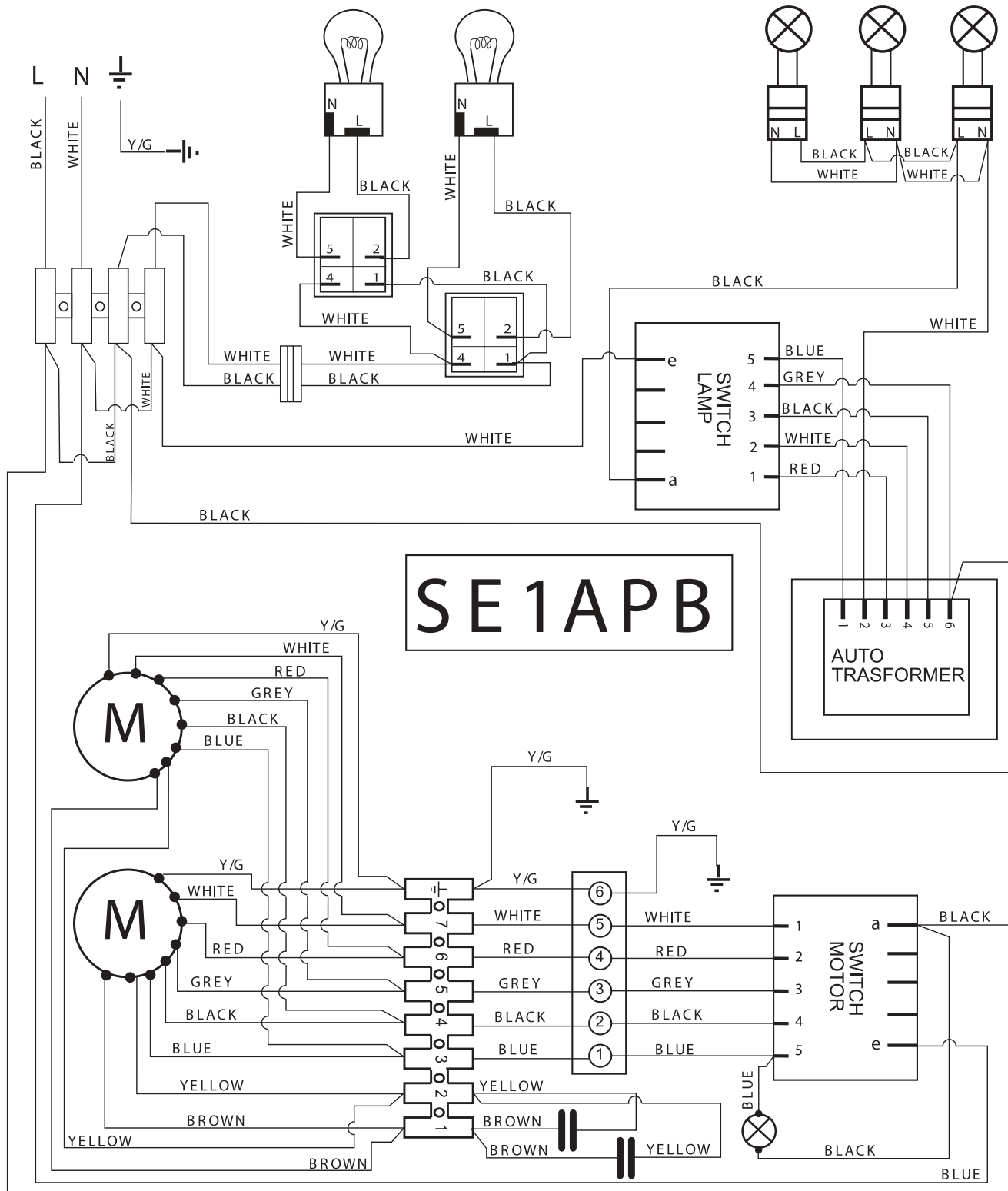

Illustrated Parts

ZV30, ZV36, and ZV48 - SSF1SS Models

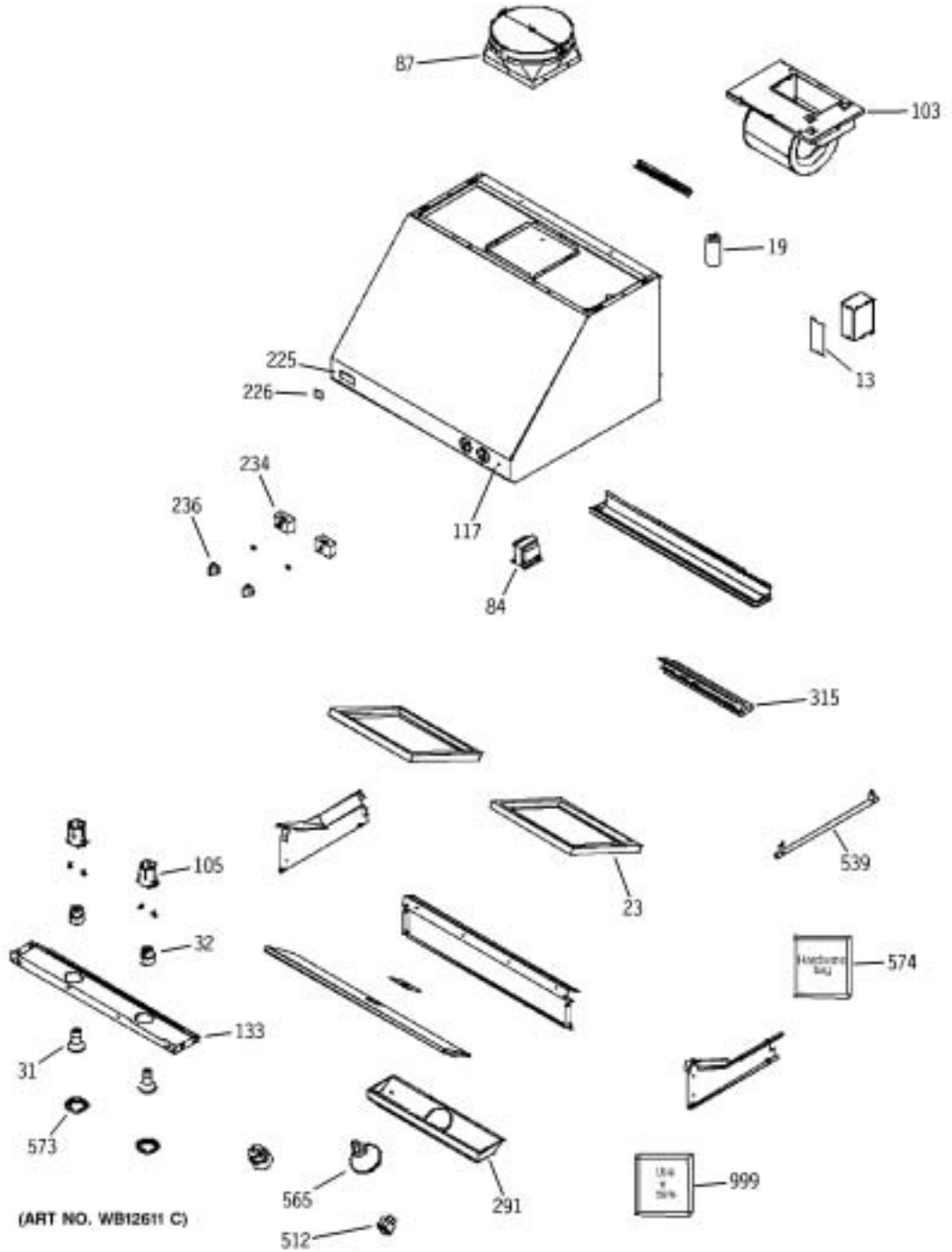

ZV30, ZV36, and ZV48 - SSF1SS Models

VIEW NUMBER	CATALOG NUMBER	DESCRIPTION	QUANTITY
13	WB02X10872	JUNCTION BOX COVER	1
19	WB27X10669	CAPACITOR	1
23	WB02X10869	FILTER, BAFFLE	2
31	WB08X10028	120V 50W HALOGEN BULB	2
32	WB08X10030	LAMPHOLDER	2
84	WB20X10026	TRANSFORMER	1
87	WB02X10871	DUCT TRANSITION W/DAMPER	1
103	WB38X10069	BLOWER ASSEMBLY	1
105	WB08X10032	LAMPHOLDER SUPPORT	2
117	WB08X10033	INDICATOR LIGHT	1
133	WB07X10607	HALOGEN LAMP PANEL 30"	1
225	WB02X10832	MONOGRAM LOGO	1
226	WB01X10070	CLIP LOGO	2
234	WB24X10110	SWITCH, MOTOR/LAMP	2
236	WB03X10163	KNOB ASSEMBLY	2
291	WB07X10608	HEAT LAMP PANEL 30"	1
315	WB02X10870	GREASE TRAY 30"	2
512	WB24X10111	HEAT-LAMP ROCKER SWITCH	1
539	WB02X10873	UTENSIL ROD-TAPER 30"	2
565	WB08X10029	120V 175W INFRARED LAMP	1
573	WB08X10031	BEZEL LAMP	2
574	WB01X10196	HARDWARE BAG	1
999	49-80150	USE & CARE MANUAL	1
999	49-80151	INSTALL INSTRUCTION	1

ZV30, ZV36, and ZV48 - TSF1SS Models

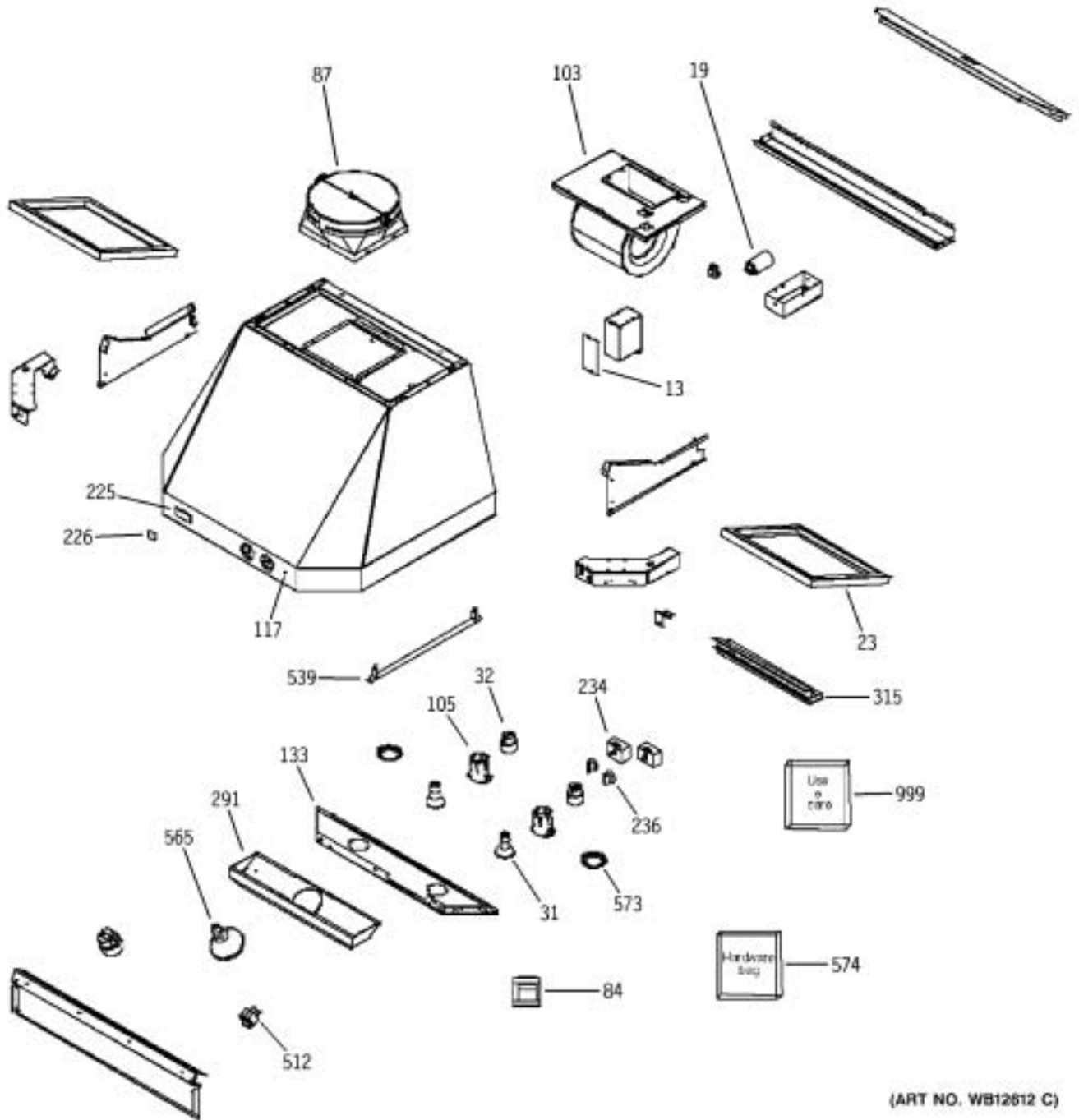

ZV30, ZV36, and ZV48 - TSF1SS Models

VIEW NUMBER	CATALOG NUMBER	DESCRIPTION	QUANTITY
13	WB02X10872	JUNCTION BOX COVER	1
19	WB27X10669	CAPACITOR	1
23	WB02X10869	FILTER, BAFFLE	2
31	WB08X10028	120V 50W HALOGEN BULB	2
32	WB08X10030	LAMPHOLDER	2
84	WB20X10026	TRANSFORMER	1
87	WB02X10871	DUCT TRANSITION W/DAMPER	1
103	WB38X10069	BLOWER ASSEMBLY	1
105	WB08X10032	LAMPHOLDER SUPPORT	2
117	WB08X10033	INDICATOR LIGHT	1
133	WB07X10613	HALOGEN LAMP PANEL 30"	1
225	WB02X10832	MONOGRAM LOGO	1
226	WB01X10070	CLIP LOGO	2
234	WB24X10110	SWITCH, MOTOR/LAMP	2
236	WB03X10163	KNOB ASSEMBLY	2
291	WB07X10608	HEAT LAMP PANEL 30"	1
315	WB02X10870	GREASE TRAY 30"	2
512	WB24X10111	HEAT-LAMP ROCKER SWITCH	1
539	WB02X10873	UTENSIL ROD-TAPER 30"	2
565	WB08X10029	120V 175W INFRARED LAMP	1
573	WB08X10031	BEZEL LAMP	2
574	WB01X10196	HARDWARE BAG	1
999	49-80150	USE & CARE MANUAL	1
999	49-80151	INSTALL INSTRUCTIONS	1

ZV30, ZV36, and ZV48 - RSF1SS Models

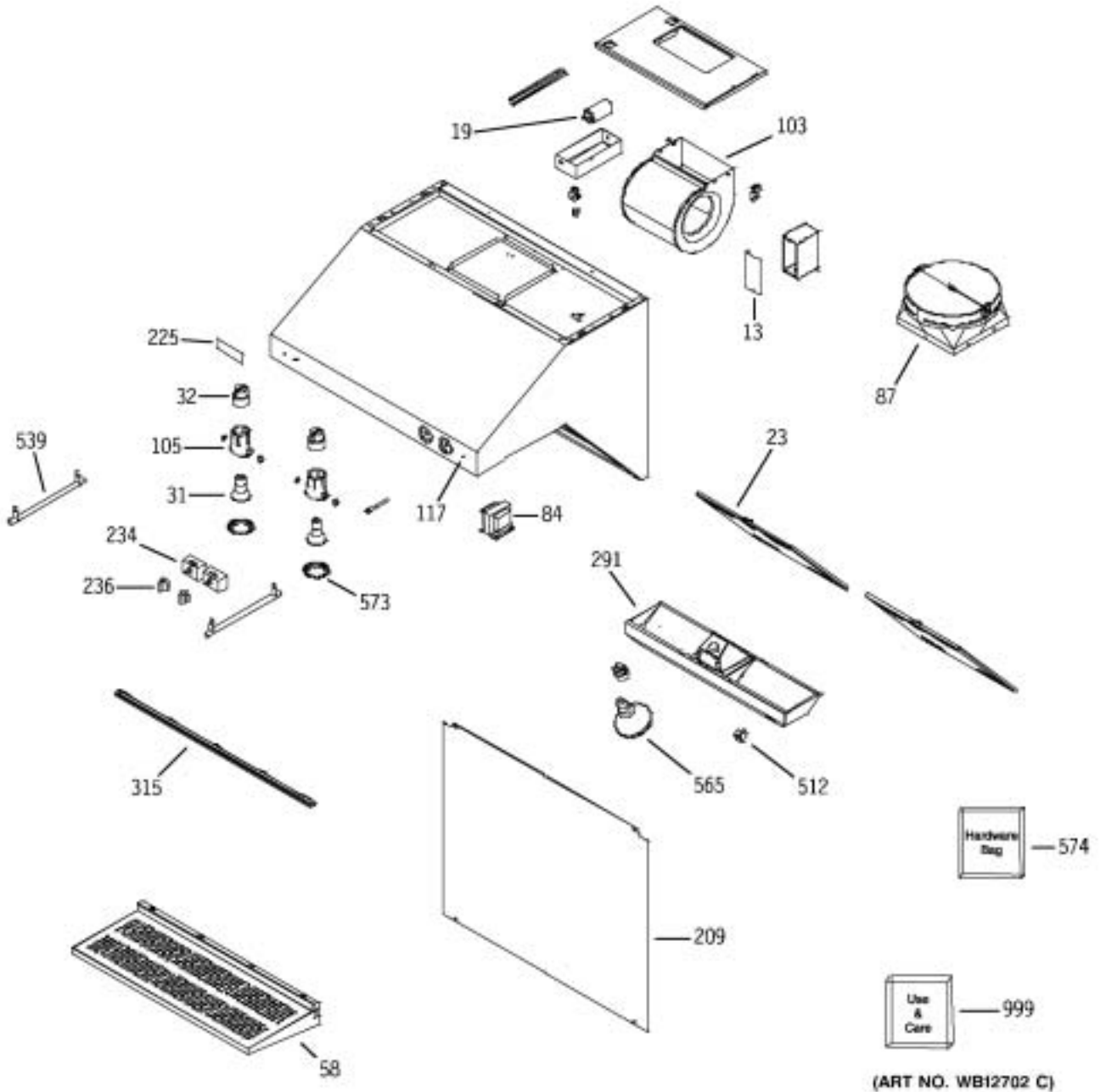

ZV30, ZV36, and ZV48 - RSF1SS Models

VIEW NUMBER	CATALOG NUMBER	DESCRIPTION	QUANTITY
13	WB02X10872	JUNCTION BOX COVER	1
19	WB27X10669	CAPACITOR	1
23	WB02X10897	FILTER, BAFFLE	2
31	WB08X10028	120V 50W HALOGEN BULB	2
32	WB08X10030	LAMPHOLDER	2
58	WB07X10660	SHELF	1
84	WB20X10026	TRANSFORMER	1
87	WB02X10871	DUCT TRANSITION W/DAMPER	1
103	WB38X10069	BLOWER ASSEMBLY	1
105	WB08X10032	LAMPHOLDER SUPPORT	2
117	WB08X10033	INDICATOR LIGHT	1
209	WB61X10004	BACK SPLASH	1
225	WB01X10070	CLIP LOGO	1
225	WB02X10832	MONOGRAM LOGO	1
234	WB24X10110	SWITCH, MOTOR/LAMP	2
236	WB03X10163	KNOB ASSEMBLY	2
291	WB07X10608	HEAT LAMP PANEL 30"	1
315	WB02X10899	GREASE TRAY 30"	2
512	WB24X10111	HEAT-LAMP ROCKER SWITCH	2
539	WB02X10900	UTENSIL ROD-TAPER 30"	2
565	WB08X10029	120V 175W INFRARED LAMP	1
573	WB08X10031	BEZEL LAMP	2
574	WB01X10211	HARDWARE BAG	1
999	49-80152	USE & CARE	1
999	49-80150-1	INSTALLATION	1

