

Main

Commercial Status	Commercialised
Range of product	Modicon ETB
Product or component type	I/O distributed module
Number of input channels	Configurable
Number of output channels	1...16 configurable
Module type	Ethernet/IP

Complementary

Input type	Contact
Input logic	Negative Positive
Delay response	2.5 ms
Output current	8 A per output 2 A per module
Output protection type	Against short-circuits
Switching frequency	200 Hz
Short-circuit current	6.5 A
[Us] rated supply voltage	24 V DC
Connector type	M12
Standards	IEC 60529 IEC 60068-2-8

Environment

IP degree of protection	IP67
Ambient air temperature for operation	> -25...70 °C
Ambient air temperature for storage	> -40...85 °C
Vibration resistance	10 gn

RoHS compliance

RoHS EUR status	Compliant
RoHS EUR conformity date(YYWW)	0923

Contractual warranty

Period	18 months
--------	-----------

Dimensions

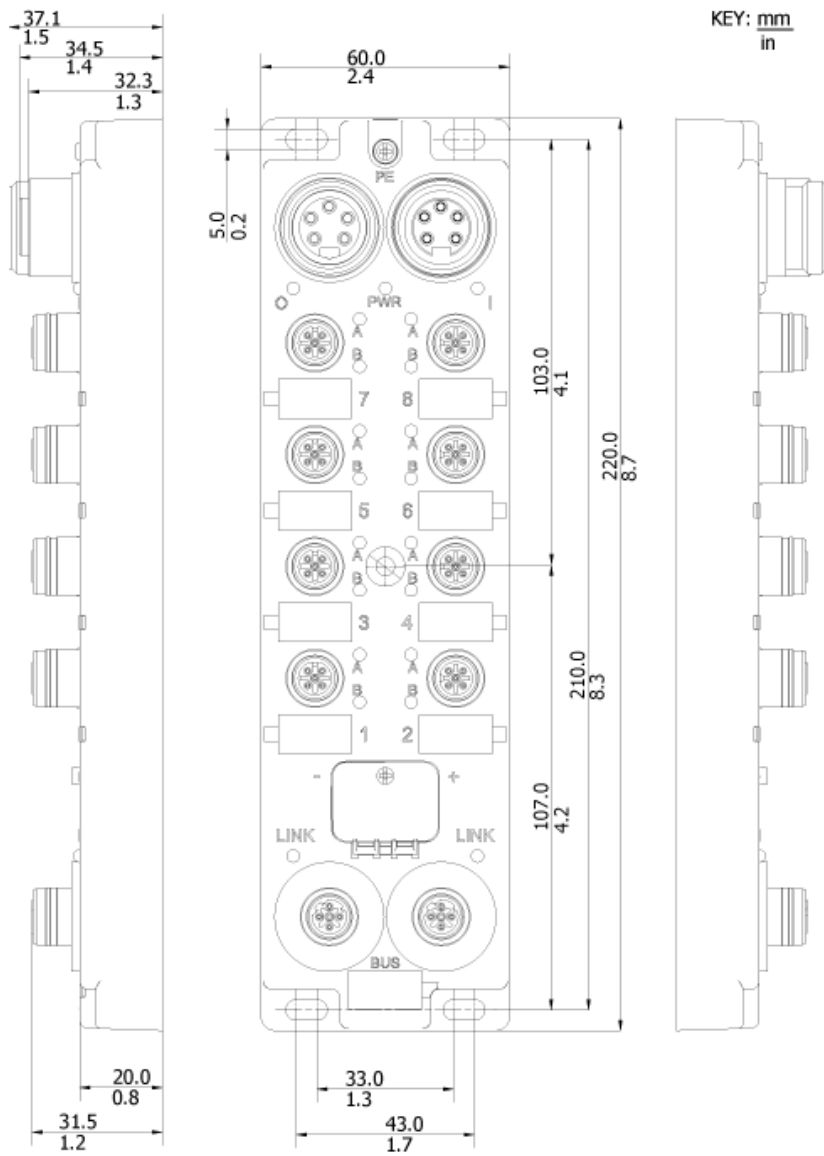

I/O Assignments

Select the number of inputs/outputs according to the product characteristics in order to get the I/O assignment.

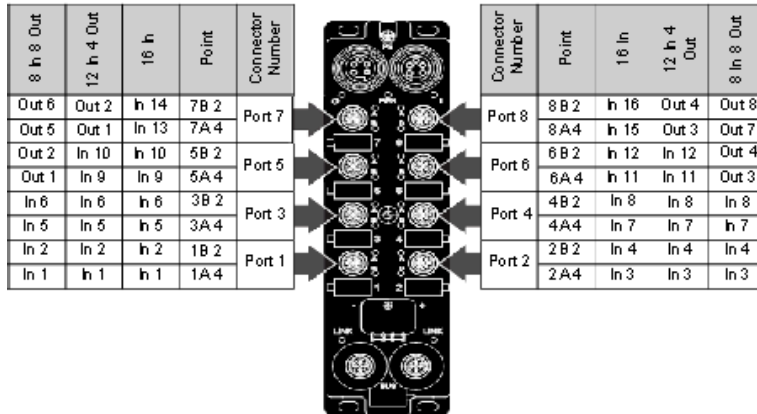

Power Connectors

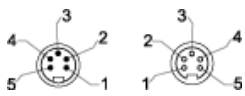

- 1 Output Power 0 Vdc
- 2 Module/Input Power 0 Vdc
- 3 Protective Earth (PE)
- 4 Module/Input Power 24 Vdc
- 5 Output Power 24 Vdc

2-Output Port

IEC Wiring Diagram with 2 Actuators

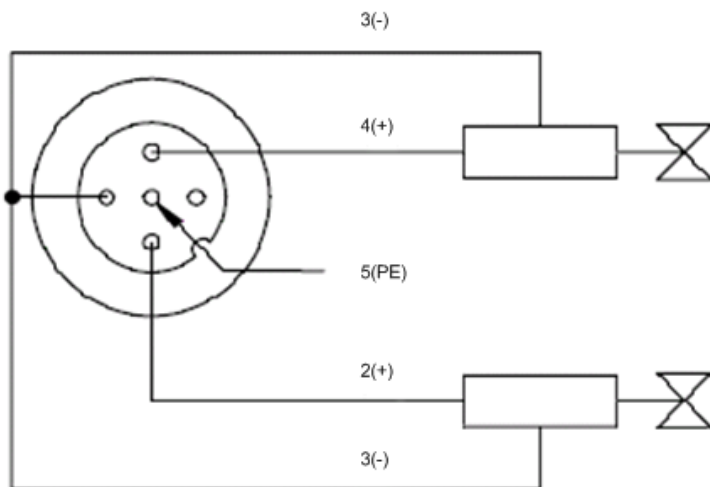

2-Input Port

IEC Wiring Diagram with 2 Sensors

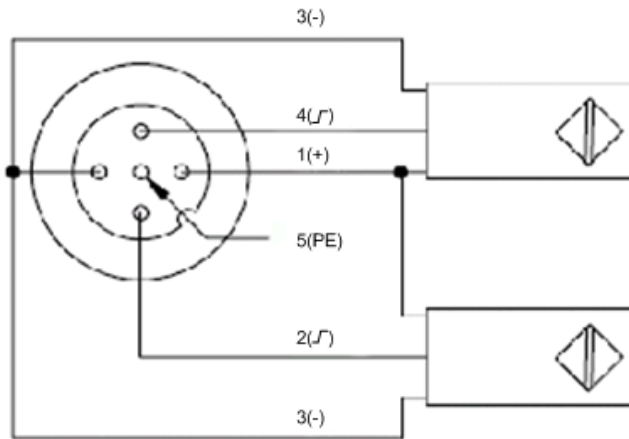

Input/Output Port

IEC Wiring Diagram with 1 Sensor and 1 Actuator

