

Upgraded Safety Limit Switches Based on the Popular D4D, Providing a Full Lineup Conforming to International Standards

Note: Contact your sales representative for details on models with safety standard certification.

- Lineup includes three contact models with 2NC/1NO and 3NC contact forms in addition to the previous contact forms 1NC/1NO, and 2NC. Models with MBB contacts are also available.
- M12-connector models are available, saving on labor and simplifying replacement.
- Standardized gold-clad contacts provide high contact reliability. Can be used with both standard loads and microloads.
- Conforms to EN115, EN81-1, and EN81-2 (slow-action models only).
- Lineup includes both slow-action and snap-action models with Zb contacts.
- Certified standards: UL, EN (TÜV), and CCC



 Be sure to read the "Safety Precautions" on page 18 and the "Precautions for All Safety Limit Switches".

Model Number Structure

Model Number Legend

D4N-□□□□
1 2 3

1. Conduit size

- 1: Pg13.5 (1-conduit)
- 2: G1/2 (1-conduit)
- 3: 1/2-14NPT (1-conduit)
- 4: M20 (1-conduit)
- 5: Pg13.5 (2-conduit)
- 6: G1/2 (2-conduit)
- 7: 1/2-14NPT (2-conduit)
- 8: M20 (2-conduit)
- 9: M12 connector (1-conduit)

2. Built-in Switch

- 1: 1NC/1NO (snap-action)
- 2: 2NC (snap-action)
- A: 1NC/1NO (slow-action)
- B: 2NC (slow-action)
- C: 2NC/1NO (slow-action)
- D: 3NC (slow-action)
- E: 1NC/1NO (MBB contact) (slow-action)
- F: 2NC/1NO (MBB contact) (slow-action)











3. Head and Actuator

- 20: Roller lever (resin lever, resin roller)
- 22: Roller lever (metal lever, resin roller)
- 25: Roller lever (metal lever, metal roller)
- 26: Roller lever (metal lever, bearing roller)
- 2G: Adjustable roller lever, form lock (metal lever, resin roller)
- 2H: Adjustable roller lever, form lock (metal lever, rubber roller)
- 31: Top Plunger
- 32: Top Roller Plunger
- 62: One-way roller arm lever (horizontal)
- 72: One-way roller arm lever (vertical)
- 80: Cat whisker
- 87: Plastic rod
- RE: Fork lever lock (right operation)
- LE: Fork lever lock (left operation)

Ordering Information











List of Models

Switches with Two Contacts (with Direct Opening Mechanism)

Actuator	Conduit size		Built-in switch mechanism								
			1NC/1NO (Snap-action)		2NC (Snap-action)		1NC/1NO (Slow-action)		2NC (Slow-action)		
			Model	Direct opening	Model	Direct opening	Model	Direct opening	Model	Direct opening	
Roller lever (resin lever, resin roller) 	1-conduit	Pg13.5	D4N-1120	⊕	D4N-1220	⊕	D4N-1A20	⊕	D4N-1B20	⊕	
		G1/2	D4N-2120		D4N-2220		D4N-2A20		D4N-2B20		
		1/2-14NPT	D4N-3120		D4N-3220		D4N-3A20		D4N-3B20		
		M20	D4N-4120		D4N-4220		D4N-4A20		D4N-4B20		
		M12 connector	D4N-9120		D4N-9220		D4N-9A20		D4N-9B20		
	2-conduit	Pg13.5	D4N-5120	⊕	D4N-5220	⊕	D4N-5A20	⊕	D4N-5B20	⊕	
		G1/2	D4N-6120		D4N-6220		D4N-6A20		D4N-6B20		
		M20	D4N-8120		D4N-8220		D4N-8A20		D4N-8B20		
Roller lever (metal lever, resin roller) 	1-conduit	Pg13.5	D4N-1122	⊕	D4N-1222	⊕	D4N-1A22	⊕	D4N-1B22	⊕	
		G1/2	D4N-2122		D4N-2222		D4N-2A22		D4N-2B22		
		1/2-14NPT	D4N-3122		D4N-3222		D4N-3A22		D4N-3B22		
		M20	D4N-4122		D4N-4222		D4N-4A22		D4N-4B22		
		M12 connector	D4N-9122		D4N-9222		D4N-9A22		D4N-9B22		
	2-conduit	Pg13.5	D4N-5122	⊕	D4N-5222	⊕	D4N-5A22	⊕	D4N-5B22	⊕	
		G1/2	D4N-6122		D4N-6222		D4N-6A22		D4N-6B22		
		M20	D4N-8122		D4N-8222		D4N-8A22		D4N-8B22		
Roller lever (metal lever, metal roller) 	1-conduit	Pg13.5	D4N-1125	⊕	D4N-1225	⊕	D4N-1A25	⊕	D4N-1B25	⊕	
		G1/2	D4N-2125		D4N-2225		D4N-2A25		D4N-2B25		
		1/2-14NPT	D4N-3125		D4N-3225		D4N-3A25		D4N-3B25		
		M20	D4N-4125		D4N-4225		D4N-4A25		D4N-4B25		
		M12 connector	D4N-9125		D4N-9225		D4N-9A25		D4N-9B25		
Roller lever (metal lever, bearing roller) 	1-conduit	Pg13.5	D4N-1126	⊕	D4N-1226	⊕	D4N-1A26	⊕	D4N-1B26	⊕	
		G1/2	D4N-2126		D4N-2226		D4N-2A26		D4N-2B26		
		1/2-14NPT	D4N-3126		D4N-3226		D4N-3A26		D4N-3B26		
		M20	D4N-4126		D4N-4226		D4N-4A26		D4N-4B26		
		M12 connector	D4N-9126		D4N-9226		D4N-9A26		D4N-9B26		
Plunger 	1-conduit	Pg13.5	D4N-1131	⊕	D4N-1231	⊕	D4N-1A31	⊕	D4N-1B31	⊕	
		G1/2	D4N-2131		D4N-2231		D4N-2A31		D4N-2B31		
		1/2-14NPT	D4N-3131		D4N-3231		D4N-3A31		D4N-3B31		
		M20	D4N-4131		D4N-4231		D4N-4A31		D4N-4B31		
		M12 connector	D4N-9131		D4N-9231		D4N-9A31		D4N-9B31		
	2-conduit	Pg13.5	D4N-5131	⊕	D4N-5231	⊕	D4N-5A31	⊕	D4N-5B31	⊕	
		G1/2	D4N-6131		D4N-6231		D4N-6A31		D4N-6B31		
		M20	D4N-8131		D4N-8231		D4N-8A31		D4N-8B31		
Roller plunger 	1-conduit	Pg13.5	D4N-1132	⊕	D4N-1232	⊕	D4N-1A32	⊕	D4N-1B32	⊕	
		G1/2	D4N-2132		D4N-2232		D4N-2A32		D4N-2B32		
		1/2-14NPT	D4N-3132		D4N-3232		D4N-3A32		D4N-3B32		
		M20	D4N-4132		D4N-4232		D4N-4A32		D4N-4B32		
		M12 connector	D4N-9132		D4N-9232		D4N-9A32		D4N-9B32		
	2-conduit	Pg13.5	D4N-5132	⊕	D4N-5232	⊕	D4N-5A32	⊕	D4N-5B32	⊕	
		G1/2	D4N-6132		D4N-6232		D4N-6A32		D4N-6B32		
		M20	D4N-8132		D4N-8232		D4N-8A32		D4N-8B32		
One-way roller arm lever (horizontal) 	1-conduit	Pg13.5	D4N-1162	⊕	D4N-1262	⊕	D4N-1A62	⊕	D4N-1B62	⊕	
		G1/2	D4N-2162		D4N-2262		D4N-2A62		D4N-2B62		
		1/2-14NPT	D4N-3162		D4N-3262		D4N-3A62		D4N-3B62		
		M20	D4N-4162		D4N-4262		D4N-4A62		D4N-4B62		
		M12 connector	D4N-9162		D4N-9262		D4N-9A62		D4N-9B62		
	2-conduit	Pg13.5	D4N-5162	⊕	D4N-5262	⊕	D4N-5A62	⊕	D4N-5B62	⊕	
		G1/2	D4N-6162		D4N-6262		D4N-6A62		D4N-6B62		
		M20	D4N-8162		D4N-8262		D4N-8A62		D4N-8B62		
One-way roller arm lever (vertical) 	1-conduit	Pg13.5	D4N-1172	⊕	D4N-1272	⊕	D4N-1A72	⊕	D4N-1B72	⊕	
		G1/2	D4N-2172		D4N-2272		D4N-2A72		D4N-2B72		
		1/2-14NPT	D4N-3172		D4N-3272		D4N-3A72		D4N-3B72		
		M20	D4N-4172		D4N-4272		D4N-4A72		D4N-4B72		
		M12 connector	D4N-9172		D4N-9272		D4N-9A72		D4N-9B72		
	2-conduit	Pg13.5	D4N-5172	⊕	D4N-5272	⊕	D4N-5A72	⊕	D4N-5B72	⊕	
		G1/2	D4N-6172		D4N-6272		D4N-6A72		D4N-6B72		
		M20	D4N-8172		D4N-8272		D4N-8A72		D4N-8B72		
Adjustable roller lever, form lock (metal lever, resin roller) 	1-conduit	Pg13.5	D4N-112G	⊕	D4N-122G	⊕	D4N-1A2G	⊕	D4N-1B2G	⊕	
		G1/2	D4N-212G		D4N-222G		D4N-2A2G		D4N-2B2G		
		1/2-14NPT	D4N-312G		D4N-322G		D4N-3A2G		D4N-3B2G		
		M20	D4N-412G		D4N-422G		D4N-4A2G		D4N-4B2G		
		M12 connector	D4N-912G		D4N-922G		D4N-9A2G		D4N-9B2G		
	2-conduit	G1/2	D4N-612G	⊕	D4N-622G	⊕	D4N-6A2G	⊕	D4N-6B2G	⊕	
		M20	D4N-812G		D4N-822G		D4N-8A2G		D4N-8B2G		
Adjustable roller lever, form lock (metal lever, rubber roller) 	1-conduit	Pg13.5	D4N-112H	⊕	D4N-122H	⊕	D4N-1A2H	⊕	D4N-1B2H	⊕	
		G1/2	D4N-212H		D4N-222H		D4N-2A2H		D4N-2B2H		
		1/2-14NPT	D4N-312H		D4N-322H		D4N-3A2H		D4N-3B2H		
		M20	D4N-412H		D4N-422H		D4N-4A2H		D4N-4B2H		
		M12 connector	D4N-912H		D4N-922H		D4N-9A2H		D4N-9B2H		
	2-conduit	G1/2	D4N-612H	⊕	D4N-622H	⊕	D4N-6A2H	⊕	D4N-6B2H	⊕	
		M20	D4N-812H		D4N-822H		D4N-8A2H		D4N-8B2H		





Note: It is recommended that M20 be used for Switches to be exported to Europe and 1/2-14NPT be used for Switches to be exported to North American countries.

Switches with Three Contacts and MBB Contacts (with Direct Opening Mechanism)

Actuator	Conduit size		Built-in switch mechanism							
			2NC/1NO (Slow-action)		3NC (Slow-action)		1NC/1NO MBB (Slow-action)		2NC/1NO MBB (Slow-action)	
			Model	Direct opening	Model	Direct opening	Model	Direct opening	Model	Direct opening
 Roller lever (resin lever, resin roller)	1-conduit	Pg13.5	D4N-1C20	⊕	D4N-1D20	⊕	D4N-1E20	⊕	D4N-1F20	⊕
		G1/2	D4N-2C20		D4N-2D20		D4N-2E20		D4N-2F20	
		1/2-14NPT	D4N-3C20		D4N-3D20		D4N-3E20		D4N-3F20	
		M20	D4N-4C20		D4N-4D20		D4N-4E20		D4N-4F20	
	M12 connector	---	---	D4N-9E20	---					
	2-conduit	Pg13.5	D4N-5C20	⊕	D4N-5D20	⊕	D4N-5E20	⊕	D4N-5F20	⊕
		G1/2	D4N-6C20		D4N-6D20		D4N-6E20		D4N-6F20	
		M20	D4N-8C20		D4N-8D20		D4N-8E20		D4N-8F20	
M12 connector		---	---		---		---			
 Roller lever (metal lever, resin roller)	1-conduit	Pg13.5	D4N-1C22	⊕	D4N-1D22	⊕	D4N-1E22	⊕	D4N-1F22	⊕
		G1/2	D4N-2C22		D4N-2D22		D4N-2E22		D4N-2F22	
		1/2-14NPT	D4N-3C22		D4N-3D22		D4N-3E22		D4N-3F22	
		M20	D4N-4C22		D4N-4D22		D4N-4E22		D4N-4F22	
	M12 connector	---	---	D4N-9E22	---					
	2-conduit	Pg13.5	D4N-5C22	⊕	D4N-5D22	⊕	D4N-5E22	⊕	D4N-5F22	⊕
		G1/2	D4N-6C22		D4N-6D22		D4N-6E22		D4N-6F22	
		M20	D4N-8C22		D4N-8D22		D4N-8E22		D4N-8F22	
M12 connector		---	---		---		---			
 Roller lever (metal lever, metal roller)	1-conduit	Pg13.5	D4N-1C25	⊕	D4N-1D25	⊕	D4N-1E25	⊕	D4N-1F25	⊕
		G1/2	D4N-2C25		D4N-2D25		D4N-2E25		D4N-2F25	
		1/2-14NPT	D4N-3C25		D4N-3D25		D4N-3E25		D4N-3F25	
		M20	D4N-4C25		D4N-4D25		D4N-4E25		D4N-4F25	
	M12 connector	---	---	D4N-9E25	---					
	2-conduit	Pg13.5	D4N-5C25	⊕	D4N-5D25	⊕	D4N-5E25	⊕	D4N-5F25	⊕
		G1/2	D4N-6C25		D4N-6D25		D4N-6E25		D4N-6F25	
		M20	D4N-8C25		D4N-8D25		D4N-8E25		D4N-8F25	
M12 connector		---	---		---		---			
 Roller lever (metal lever, bearing roller)	1-conduit	Pg13.5	D4N-1C26	⊕	D4N-1D26	⊕	D4N-1E26	⊕	D4N-1F26	⊕
		G1/2	D4N-2C26		D4N-2D26		D4N-2E26		D4N-2F26	
		1/2-14NPT	D4N-3C26		D4N-3D26		D4N-3E26		D4N-3F26	
		M20	D4N-4C26		D4N-4D26		D4N-4E26		D4N-4F26	
	M12 connector	---	---	D4N-9E26	---					
	2-conduit	Pg13.5	D4N-5C26	⊕	D4N-5D26	⊕	D4N-5E26	⊕	D4N-5F26	⊕
		G1/2	D4N-6C26		D4N-6D26		D4N-6E26		D4N-6F26	
		M20	D4N-8C26		D4N-8D26		D4N-8E26		D4N-8F26	
M12 connector		---	---		---		---			
 Plunger	1-conduit	Pg13.5	D4N-1C31	⊕	D4N-1D31	⊕	D4N-1E31	⊕	D4N-1F31	⊕
		G1/2	D4N-2C31		D4N-2D31		D4N-2E31		D4N-2F31	
		1/2-14NPT	D4N-3C31		D4N-3D31		D4N-3E31		D4N-3F31	
		M20	D4N-4C31		D4N-4D31		D4N-4E31		D4N-4F31	
	M12 connector	---	---	D4N-9E31	---					
	2-conduit	Pg13.5	D4N-5C31	⊕	D4N-5D31	⊕	D4N-5E31	⊕	D4N-5F31	⊕
		G1/2	D4N-6C31		D4N-6D31		D4N-6E31		D4N-6F31	
		M20	D4N-8C31		D4N-8D31		D4N-8E31		D4N-8F31	
M12 connector		---	---		---		---			
 Roller plunger	1-conduit	Pg13.5	D4N-1C32	⊕	D4N-1D32	⊕	D4N-1E32	⊕	D4N-1F32	⊕
		G1/2	D4N-2C32		D4N-2D32		D4N-2E32		D4N-2F32	
		1/2-14NPT	D4N-3C32		D4N-3D32		D4N-3E32		D4N-3F32	
		M20	D4N-4C32		D4N-4D32		D4N-4E32		D4N-4F32	
	M12 connector	---	---	D4N-9E32	---					
	2-conduit	Pg13.5	D4N-5C32	⊕	D4N-5D32	⊕	D4N-5E32	⊕	D4N-5F32	⊕
		G1/2	D4N-6C32		D4N-6D32		D4N-6E32		D4N-6F32	
		M20	D4N-8C32		D4N-8D32		D4N-8E32		D4N-8F32	
M12 connector		---	---		---		---			
 One-way roller arm lever (horizontal)	1-conduit	Pg13.5	D4N-1C62	⊕	D4N-1D62	⊕	D4N-1E62	⊕	D4N-1F62	⊕
		G1/2	D4N-2C62		D4N-2D62		D4N-2E62		D4N-2F62	
		1/2-14NPT	D4N-3C62		D4N-3D62		D4N-3E62		D4N-3F62	
		M20	D4N-4C62		D4N-4D62		D4N-4E62		D4N-4F62	
	M12 connector	---	---	D4N-9E62	---					
	2-conduit	Pg13.5	D4N-5C62	⊕	D4N-5D62	⊕	D4N-5E62	⊕	D4N-5F62	⊕
		G1/2	D4N-6C62		D4N-6D62		D4N-6E62		D4N-6F62	
		M20	D4N-8C62		D4N-8D62		D4N-8E62		D4N-8F62	
M12 connector		---	---		---		---			
 One-way roller arm lever (vertical)	1-conduit	Pg13.5	D4N-1C72	⊕	D4N-1D72	⊕	D4N-1E72	⊕	D4N-1F72	⊕
		G1/2	D4N-2C72		D4N-2D72		D4N-2E72		D4N-2F72	
		1/2-14NPT	D4N-3C72		D4N-3D72		D4N-3E72		D4N-3F72	
		M20	D4N-4C72		D4N-4D72		D4N-4E72		D4N-4F72	
	M12 connector	---	---	D4N-9E72	---					
	2-conduit	Pg13.5	D4N-5C72	⊕	D4N-5D72	⊕	D4N-5E72	⊕	D4N-5F72	⊕
		G1/2	D4N-6C72		D4N-6D72		D4N-6E72		D4N-6F72	
		M20	D4N-8C72		D4N-8D72		D4N-8E72		D4N-8F72	
M12 connector		---	---		---		---			
 Adjustable roller lever, form lock (metal lever, resin roller)	1-conduit	Pg13.5	D4N-1C2G	⊕	D4N-1D2G	⊕	D4N-1E2G	⊕	D4N-1F2G	⊕
		G1/2	D4N-2C2G		D4N-2D2G		D4N-2E2G		D4N-2F2G	
		1/2-14NPT	D4N-3C2G		D4N-3D2G		D4N-3E2G		D4N-3F2G	
		M20	D4N-4C2G		D4N-4D2G		D4N-4E2G		D4N-4F2G	
	M12 connector	---	---	D4N-9E2G	---					
	2-conduit	G1/2	D4N-6C2G	⊕	D4N-6D2G	⊕	D4N-6E2G	⊕	D4N-6F2G	⊕
		M20	D4N-8C2G		D4N-8D2G		D4N-8E2G		D4N-8F2G	
		M12 connector	---		---		---		---	
M12 connector		---	---		---		---			
 Adjustable roller lever, form lock (metal lever, rubber roller)	1-conduit	Pg13.5	D4N-1C2H	⊕	D4N-1D2H	⊕	D4N-1E2H	⊕	D4N-1F2H	⊕
		G1/2	D4N-2C2H		D4N-2D2H		D4N-2E2H		D4N-2F2H	
		1/2-14NPT	D4N-3C2H		D4N-3D2H		D4N-3E2H		D4N-3F2H	
		M20	D4N-4C2H		D4N-4D2H		D4N-4E2H		D4N-4F2H	
	M12 connector	---	---	D4N-9E2H	---					
	2-conduit	G1/2	D4N-6C2H	⊕	D4N-6D2H	⊕	D4N-6E2H	⊕	D4N-6F2H	⊕
		M20	D4N-8C2H		D4N-8D2H		D4N-8E2H		D4N-8F2H	
		M12 connector	---		---		---		---	
M12 connector		---	---		---		---			





Note: It is recommended that M20 be used for Switches to be exported to Europe and 1/2-14NPT be used for Switches to be exported to North American countries.

General-purpose Switches with Two Contacts

Actuator	Conduit size		Built-in switch mechanism								
			1NC/1NO (Snap-action)		2NC (Snap-action)		1NC/1NO (Slow-action)		2NC (Slow-action)		
			Model	Direct opening	Model	Direct opening	Model	Direct opening	Model	Direct opening	
Fork lever lock (right operation) 	1-conduit	G1/2	---	---	---	---	---	D4N-2ARE	---	D4N-2BRE	---
		1/2-14NPT						D4N-3ARE		D4N-3BRE	
		M20						D4N-4ARE		D4N-4BRE	
	2-conduit	G1/2	---	---	---	---	D4N-6ARE	---	D4N-6BRE	---	
		M20	---	---	---	---	D4N-8ARE	---	D4N-8BRE	---	
Fork lever lock (left operation) 	1-conduit	G1/2	---	---	---	---	---	D4N-2ALE	---	D4N-2BLE	---
		1/2-14NPT						D4N-3ALE		D4N-3BLE	
		M20						D4N-4ALE		D4N-4BLE	
	2-conduit	G1/2	---	---	---	---	D4N-6ALE	---	D4N-6BLE	---	
		M20	---	---	---	---	D4N-8ALE	---	D4N-8BLE	---	
Cat whisker 	1-conduit	G1/2	D4N-2180	---	D4N-2280	---	---	---	---	D4N-2B80	---
		1/2-14NPT	D4N-3180		D4N-3280					D4N-3B80	
		M20	D4N-4180		D4N-4280					D4N-4B80	
	2-conduit	G1/2	D4N-6180	---	D4N-6280	---	---	---	D4N-6B80	---	
		M20	D4N-8180	---	D4N-8280	---	---	---	D4N-8B80	---	
Plastic rod 	1-conduit	G1/2	D4N-2187	---	D4N-2287	---	---	---	---	D4N-2B87	---
		1/2-14NPT	D4N-3187		D4N-3287					D4N-3B87	
		M20	D4N-4187		D4N-4287					D4N-4B87	
	2-conduit	G1/2	D4N-6187	---	D4N-6287	---	---	---	D4N-6B87	---	
		M20	D4N-8187	---	D4N-8287	---	---	---	D4N-8B87	---	

Note: 1. It is recommended that M20 be used for Switches to be exported to Europe and 1/2-14NPT be used for Switches to be exported to North American countries.
2. Mechanically speaking, these models are basic limit switches.

General-purpose Switches with Three Contacts and MBB Contacts

Actuator	Conduit size		Built-in switch mechanism									
			2NC/1NO (Slow-action)		3NC (Slow-action)		1NC/1NO MBB (Slow-action)		2NC/1NO MBB (Slow-action)			
			Model	Direct opening	Model	Direct opening	Model	Direct opening	Model	Direct opening		
Fork lever lock (right operation) 	1-conduit	G1/2	D4N-2CRE	---	D4N-2DRE	---	---	---	---	D4N-2FRE	---	
		1/2-14NPT	D4N-3CRE		D4N-3DRE					D4N-3ERE		D4N-3FRE
		M20	D4N-4CRE		D4N-4DRE					D4N-4ERE		D4N-4FRE
	2-conduit	G1/2	D4N-6CRE	---	D4N-6DRE	---	D4N-6ERE	---	D4N-6FRE	---		
		M20	D4N-8CRE	---	D4N-8DRE	---	D4N-8ERE	---	D4N-8FRE	---		
Fork lever lock (left operation) 	1-conduit	G1/2	D4N-2CLE	---	D4N-2DLE	---	---	---	---	D4N-2FLE	---	
		1/2-14NPT	D4N-3CLE		D4N-3DLE					D4N-3ELE		D4N-3FLE
		M20	D4N-4CLE		D4N-4DLE					D4N-4ELE		D4N-4FLE
	2-conduit	G1/2	D4N-6CLE	---	D4N-6DLE	---	D4N-6ELE	---	D4N-6FLE	---		
		M20	D4N-8CLE	---	D4N-8DLE	---	D4N-8ELE	---	D4N-8FLE	---		
Cat whisker 	1-conduit	G1/2	---	---	D4N-2D80	---	---	---	---	---	---	
		1/2-14NPT			D4N-3D80							D4N-4D80
		M20			D4N-6D80							D4N-8D80
	2-conduit	G1/2	---	---	---	---	---	---	---	---	---	
		M20	---	---	---	---	---	---	---	---		
Plastic rod 	1-conduit	G1/2	---	---	D4N-2D87	---	---	---	---	---	---	
		1/2-14NPT			D4N-3D87							D4N-4D87
		M20			D4N-6D87							D4N-8D87
	2-conduit	G1/2	---	---	---	---	---	---	---	---	---	
		M20	---	---	---	---	---	---	---	---		

Note: 1. It is recommended that M20 be used for Switches to be exported to Europe and 1/2-14NPT be used for Switches to be exported to North American countries.
2. Mechanically speaking, these models are basic limit switches.

Specifications

Standards and EC Directives

Conforms to the following EC Directives:

- Machinery Directive
- Low Voltage Directive
- EN50047
- EN60204-1
- EN1088
- GS-ET-15

Certified Standards

Certification body	Standard	File No.
TÜV Product Service	EN60947-5-1 (certified direct opening)	*1
UL *2	UL508, CSA C22.2 No.14	E76675
CQC (CCC) *3	GB14048.5	2004010305105973

*1. Consult your OMRON representative for details.

*2. Certification for CSA C22.2 No. 14 is authorized by the UL mark.

*3. Ask your OMRON representative for information on certified models.

Certified Standard Ratings

TÜV (EN60947-5-1), CCC (GB14048.5)

Item	Utilization category	AC-15	DC-13
Rated operating current (I _e)		3 A	0.27 A
Rated operating voltage (U _e)		240 V	250 V

Note: Use a 10 A fuse type gI or gG that conforms to IEC269 as a short-circuit protection device. This fuse is not built into the Switch.

UL/CSA (UL508, CSA C22.2 No. 14)

A300

Rated voltage	Carry current	Current (A)		Volt-amperes (VA)	
		Make	Break	Make	Break
120 VAC	10 A	60	6	7,200	720
240 VAC		30	3		

Q300

Rated voltage	Carry current	Current (A)		Volt-amperes (VA)	
		Make	Break	Make	Break
125 VDC	2.5 A	0.55	0.55	69	69
250 VDC		0.27	0.27		

Characteristics

Degree of protection *1		IP67 (EN60947-5-1)
Durability *2	Mechanical	15,000,000 operations min. *5
	Electrical	500,000 operations min. (3 A resistive load at 250 VAC) *3 300,000 operations min. (10 A resistive load at 250 VAC)
Operating speed		1 to 500 mm/s (D4N-1120)
Operating frequency		30 operations/minute max.
Contact resistance		25 mΩ max.
Minimum applicable load *4		1 mA resistive load at 5 VDC (N-level reference value)
Rated insulation voltage (U_i)		300 V
Rated frequency		50/60 Hz
Protection against electric shock		Class II (double insulation)
Pollution degree (operating environment)		3 (EN60947-5-1)
Impulse withstand voltage (EN60947-5-1)	Between terminals of same polarity	2.5 kV
	Between terminals of different polarity	4 kV
	Between each terminal and non-current carrying metallic parts	6 kV
Insulation resistance		100 MΩ min.
Contact gap		Snap-action: 2 × 0.5 mm min. Slow-action: 2 × 2 mm min.
Vibration resistance	Malfunction	10 to 55 Hz, 0.75 mm single amplitude
Shock resistance	Destruction	1,000 m/s ² min.
	Malfunction	300 m/s ² min.
Conditional short-circuit current		100 A (EN60947-5-1)
Conventional free air thermal current (I_{th})		10 A (EN60947-5-1)
Ambient operating temperature		-30 to 70°C (with no icing)
Ambient operating humidity		95% max.
Weight		Approx. 82 g (D4N-1120) Approx. 99 g (D4N-5120)

Note: 1. The above values are initial values.

2. Once a contact has been used to switch a standard load, it cannot be used for a load of a smaller capacity.

Doing so may result in roughening of the contact surface and contact reliability may be lost.

*1. The degree of protection is tested using the method specified by the standard (EN60947-5-1). Confirm that sealing properties are sufficient for the operating conditions and environment beforehand. Although the switch box is protected from dust or water penetration, do not use the D4N in places where foreign material such as dust, dirt, oil, water, or chemicals may penetrate through the head. Otherwise, accelerated wear, Switch damage or malfunctioning may occur.

*2. The durability is for an ambient temperature of 5 to 35°C and an ambient humidity of 40% to 70%. For more details, consult your OMRON representative.

*3. Do not pass the 3 A, 250 VAC load through more than 2 circuits.

*4. This value will vary with the switching frequency, environment, and reliability level. Confirm that correct operation is possible with the actual load beforehand.

*5. The mechanical durability of fork lever lock models is 10,000,000 operations min.

Structure and Nomenclature

Structure

Safety-oriented Lever Setting (Form-lock construction)
Grooves which engage the lever are cut in the lever and rotary shaft to prevent the lever from slipping against the rotary shaft.
There are resin-lever and metal-lever types.

Head
The direction of the switch head can be varied to any of the four directions. (Roller plunger models can be mounted in either of two directions at a 90° angle.)

Built-in Switch
The built-in switch has a direct opening mechanism that forcibly separates the NC contact even when there is contact deposit.

Cover
The cover, with a hinge on its lower part, can be opened by removing the screw of the cover, which ensures ease of maintenance and wiring.

Conduit Opening
A wide variety of conduits is available.

Size	Box	1-conduit	2-conduit
Pg13.5		Yes	Yes
G1/2		Yes	Yes
1/2-14NPT		Yes	Yes
M20		Yes	Yes
M12 connector		Yes	---

Note: M12 connector types are not available for Switches with three contacts.

Direct Opening Mechanism 1NC/1NO Contact (Slow-action)

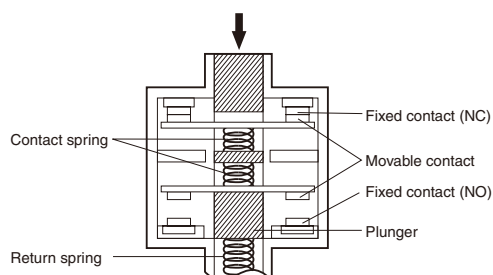

Conforms to EN60947-5-1 Direct Opening Operation ⊖

(Only the NC contact side has a direct opening mechanism.)
When contact welding occurs, the contacts are separated from each other by the plunger being pushed in.

2NC Contact (Slow-action)

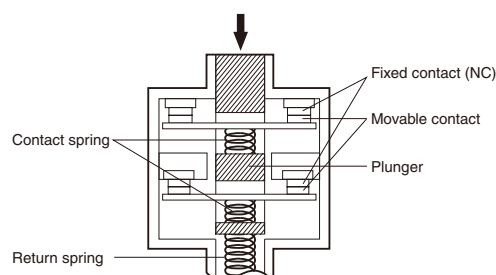

Conforms to EN60947-5-1 Direct Opening Operation ⊖

(Both NC contacts have a direct opening mechanism.)

Contact Form

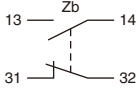
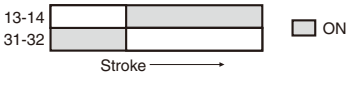
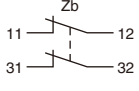
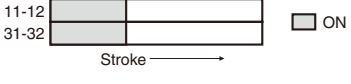
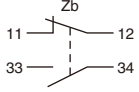
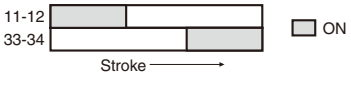
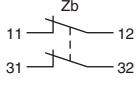
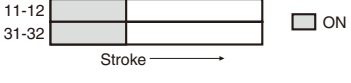
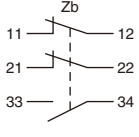
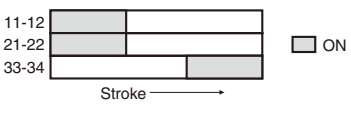
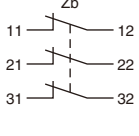
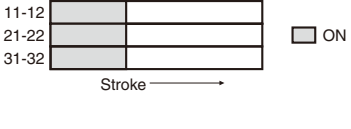
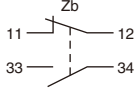
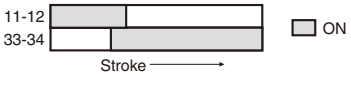
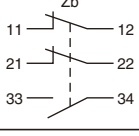
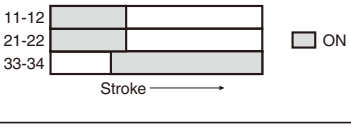
Model	Contact	Contact form	Operating pattern	Remarks
D4N-□1□	1NC/1NO (Snap-action)			Only NC contacts 31-32 have a certified direct opening mechanism. (→) The terminals 13-14 and 31-32 can be used as unlike poles.
D4N-□2□	2NC (Snap-action)			Only NC contacts 11-12 and 31-32 have a certified direct opening mechanism. (→) The terminals 11-12 and 31-32 can be used as unlike poles.
D4N-□A□	1NC/1NO (Slow-action)			Only NC contacts 11-12 have a certified direct opening mechanism. (→) The terminals 11-12 and 33-34 can be used as unlike poles.
D4N-□B□	2NC (Slow-action)			Only NC contacts 11-12 and 31-32 have a certified direct opening mechanism. (→) The terminals 11-12 and 31-32 can be used as unlike poles.
D4N-□C□	2NC/1NO (Slow-action)			Only NC contacts 11-12 and 21-22 have a certified direct opening mechanism. (→) The terminals 11-12, 21-22, and 33-34 can be used as unlike poles.
D4N-□D□	3NC (Slow-action)			Only NC contacts 11-12, 21-22, and 31-32 have a certified direct opening mechanism. (→) The terminals 11-12, 21-22, and 31-32 can be used as unlike poles.
D4N-□E□	1NC/1NO MBB * (Slow-action)			Only NC contacts 11-12 have a certified direct opening mechanism. (→) The terminals 11-12 and 33-34 can be used as unlike poles.
D4N-□F□	2NC/1NO MBB * (Slow-action)			Only NC contacts 11-12 and 21-22 have a certified direct opening mechanism. (→) The terminals 11-12, 21-22 and 33-34 can be used as unlike poles.

Note: Terminals are numbered according to EN50013 and the contact forms are according to IEC947-5-1.

*MBB (Make Before Break) contacts have an overlapping structure, so that before the normally closed contact (NC) opens, the normally open contact (NO) closes.

Dimensions and Operating Characteristics

Switches

1-conduit Models

Roller Lever (Resin Lever, Resin Roller)

D4N-1□20 D4N-2□20
 D4N-3□20 D4N-4□20
 D4N-9□20 *

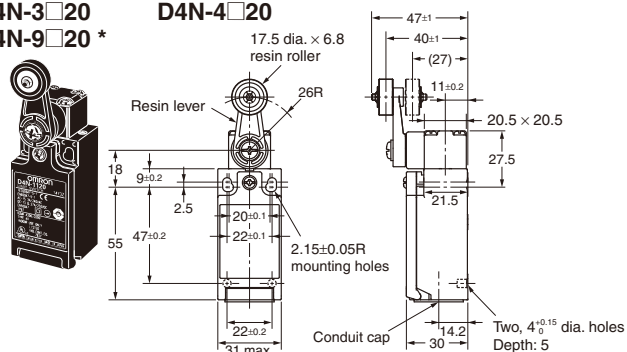

Roller Lever (Metal Lever, Resin Roller)

D4N-1□22 D4N-2□22
 D4N-3□22 D4N-4□22
 D4N-9□22 *

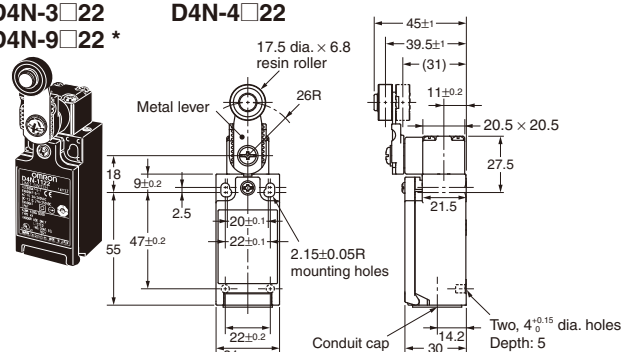

Roller Lever (Metal Lever, Metal Roller)

D4N-1□25 D4N-2□25
 D4N-3□25 D4N-4□25
 D4N-9□25 *

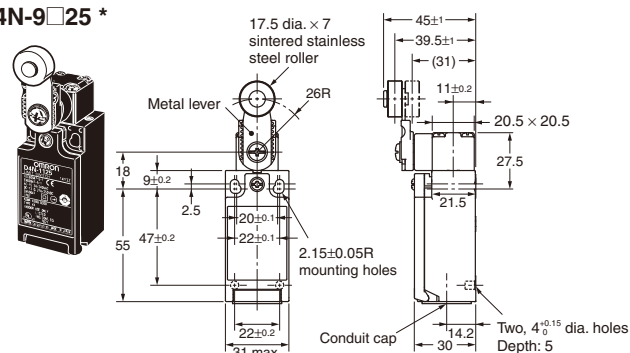

Roller Lever (Metal Lever, Bearing Roller)

D4N-1□26 D4N-2□26
 D4N-3□26 D4N-4□26
 D4N-9□26 *

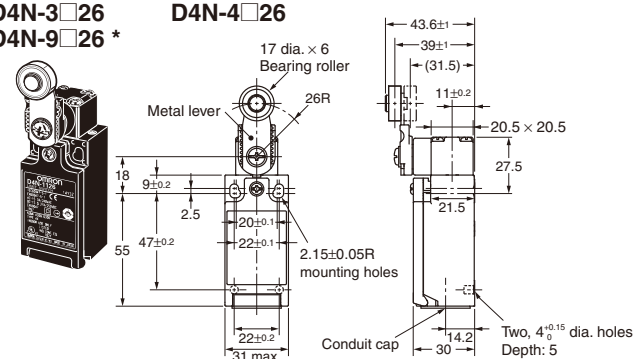

Note: Unless otherwise specified, a tolerance of ± 0.4 mm applies to all dimensions.

* Refer to page 12 for details on M12 connectors.

Snap-action (1NC/1NO) (2NC), Slow-action (2NC) (3NC)

Model	D4N-□120	D4N-□122	D4N-□125	D4N-□126
	D4N-□220	D4N-□222	D4N-□225	D4N-□226
	D4N-□B20	D4N-□B22	D4N-□B25	D4N-□B26
	D4N-□D20	D4N-□D22	D4N-□D25	D4N-□D26
Operating characteristics				
Operating force	OF max.	5.0 N		
Release force	RF min.	0.5 N		
Pretravel	PT	18° to 27°		
Overtravel	OT min.	40°		
Movement differential	MD max. *1	14°		
Operating position	OP	---		
Total travel	TT *2	(80°)		
Direct opening travel	DOT min. *3	50°		
Direct opening force	DOF min. *3	20 N		

Note: Variation occurs in the simultaneity of contact opening/closing operations of 2NC, 2NC/1NO, and 3NC contacts. Check contact operation.

*1. Only for snap-action models.

*2. Reference value.

*3. For safe use, always make sure that the minimum values or greater are provided.

Slow-action (1NC/1NO) (2NC/1NO)

Model	D4N-□A20	D4N-□A22	D4N-□A25	D4N-□A26
	D4N-□C20	D4N-□C22	D4N-□C25	D4N-□C26
	D4N-□E20	D4N-□E22	D4N-□E25	D4N-□E26
	D4N-□F20	D4N-□F22	D4N-□F25	D4N-□F26
Operating characteristics				
Operating force	OF max.	5.0 N		
Release force	RF min.	0.5 N		
	PT *1	18° to 27°		
	PT (2nd) *2	(44°)		
	PT *3	27.5° to 36.5°		
	PT (2nd) *4	(18°)		
Overtravel	OT min.	40°		
Operating position	OP	---		
Total travel	TT *5	(80°)		
Direct opening travel	DOT min. *6	50°		
Direct opening force	DOF min. *6	20 N		

*1. These PT values are possible when the NC contacts are open (OFF).

*2. These PT values are possible when the NO contacts are closed (ON).

*3. Only for MBB models.

*4. Reference values for MBB models only.

*5. Reference values.

*6. For safe use, always make sure that the minimum values or greater are provided.

1-conduit Models

Plunger

- D4N-1□31 D4N-2□31
- D4N-3□31 D4N-4□31
- D4N-9□31 *

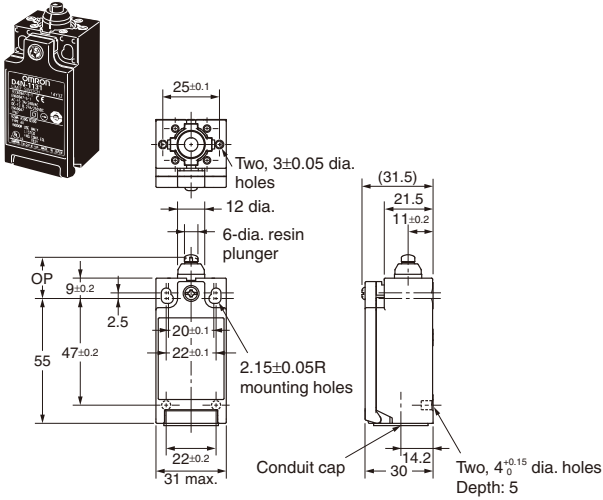

Roller Plunger

- D4N-1□32 D4N-2□32
- D4N-3□32 D4N-4□32
- D4N-9□32 *

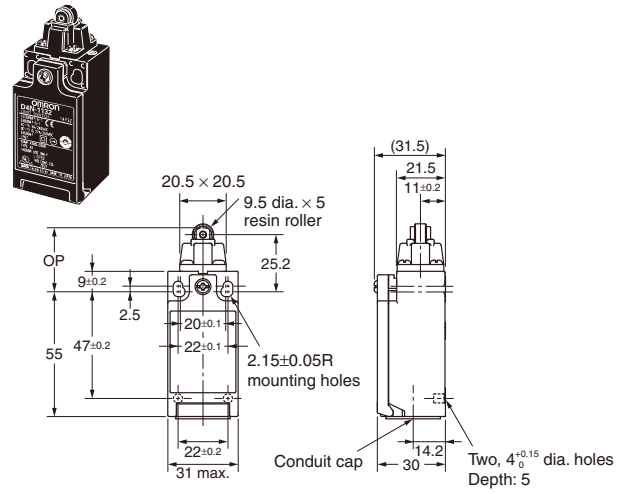

One-way Roller Arm Lever (Horizontal)

- D4N-1□62 D4N-2□62
- D4N-3□62 D4N-4□62
- D4N-9□62 *

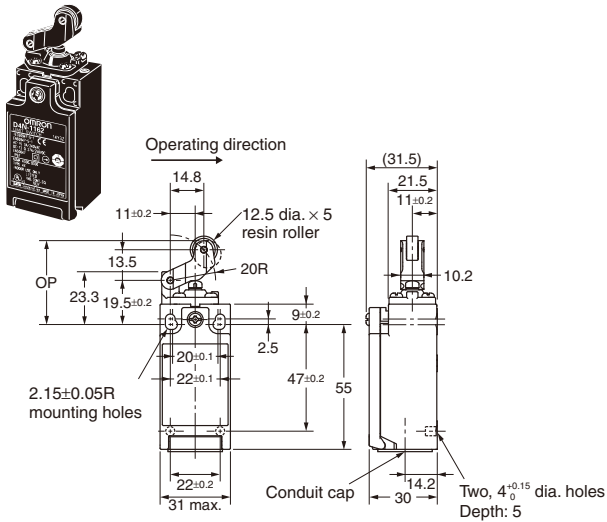

One-way Roller Arm Lever (Vertical)

- D4N-1□72 D4N-2□72
- D4N-3□72 D4N-4□72
- D4N-9□72 *

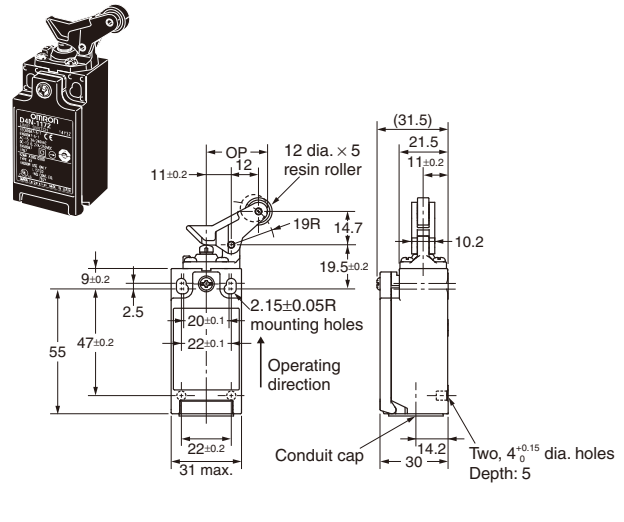

Note: Unless otherwise specified, a tolerance of ±0.4 mm applies to all dimensions.

* Refer to page 12 for details on M12 connectors.

Snap-action (1NC/1NO) (2NC), Slow-action (2NC) (3NC)

Model		D4N-□131 D4N-□231 D4N-□B31 D4N-□D31	D4N-□132 D4N-□232 D4N-□B32 D4N-□D32	D4N-□162 D4N-□262 D4N-□B62 D4N-□D62	D4N-□172 D4N-□272 D4N-□B72 D4N-□D72
Operating characteristics					
Operating force	OF max.	6.5 N	6.5 N	5.0 N	5.0 N
Release force	RF min.	1.5 N	1.5 N	0.8 N	0.8 N
Pretravel	PT max.	2 mm	2 mm	4 mm	4 mm
Overtravel	OT min.	4 mm	4 mm	5 mm	5 mm
Movement differential	MD max. *1	1 mm	1 mm	1.5 mm	1.5 mm
Operating position	OP	18.2 ±0.5 mm	28.6 ±0.8 mm	37 ±0.8 mm	27 ±0.8 mm
Total travel	TT *2	(6 mm)	(6 mm)	(9 mm)	(9 mm)
Direct opening travel	DOT min. *3	3.2 mm	3.2 mm	5.8 mm	4.8 mm
Direct opening force	DOF min. *3	20 N	20 N	20 N	20 N

Note: Variation occurs in the simultaneity of contact opening/closing operations of 2NC, 2NC/1NO, and 3NC contacts. Check contact operation.

*1. Only for snap-action models.

*2. Reference value.

*3. For safe use, always make sure that the minimum values or greater are provided.

Slow-action (1NC/1NO) (2NC/1NO)

Model		D4N-□A31 D4N-□C31 D4N-□E31 D4N-□F31	D4N-□A32 D4N-□C32 D4N-□E32 D4N-□F32	D4N-□A62 D4N-□C62 D4N-□E62 D4N-□F62	D4N-□A72 D4N-□C72 D4N-□E72 D4N-□F72
Operating characteristics					
Operating force	OF max.	6.5 N	6.5 N	5.0 N	5.0 N
Release force	RF min.	1.5 N	1.5 N	0.8 N	0.8 N
Pretravel	PT max. *1	2 mm	2 mm	4 mm	4 mm
	PT (2nd) *2	(2.9 mm)	(2.9 mm)	(5.2 mm)	(4.3 mm)
	PT max. *3	2.8 mm	2.8 mm	4 mm	4 mm
	PT (2nd) *4	(1 mm)	(1 mm)	(1.5 mm)	(1.5 mm)
Overtravel	OT min.	4 mm	4 mm	5 mm	5 mm
	Operating position	OP	18.2 ±0.5 mm	28.6 ±0.8 mm	37 ±0.8 mm
	OP *5	17.4 ±0.5 mm	28 ±0.8 mm	36 ±0.8 mm	26.1 ±0.8 mm
Total travel	TT *6	(6 mm)	(6 mm)	(9 mm)	(9 mm)
Direct opening travel	DOT min. *7	3.2 mm	3.2 mm	5.8 mm	4.8 mm
Direct opening force	DOF min. *7	20 N	20 N	20 N	20 N

*1. These PT values are possible when the NC contacts are open (OFF).

*2. These PT values are possible when the NO contacts are closed (ON).

*3. Only for MBB models.

*4. Reference values for MBB models.

*5. Only for MBB models.

*6. Reference value.

*7. For safe use, always make sure that the minimum values or greater are provided.

1-conduit Models

Adjustable Roller Lever, Form Lock
(with Metal Lever, Resin Roller)

D4N-1□2G
D4N-3□2G
D4N-9□2G *

D4N-2□2G
D4N-4□2G

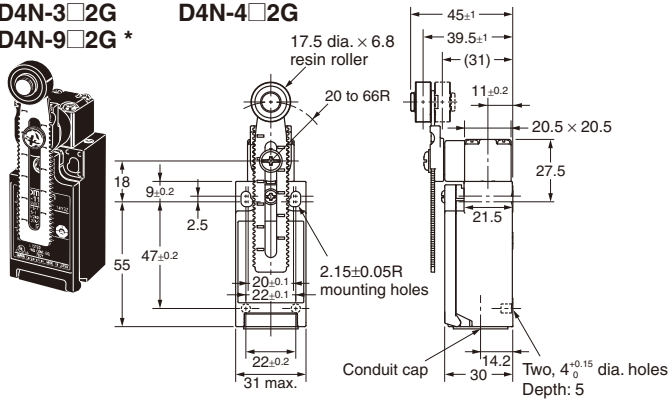

Adjustable Roller Lever, Form Lock
(with Metal Lever, Rubber Roller)

D4N-1□2H
D4N-3□2H
D4N-9□2H *

D4N-2□2H
D4N-4□2H

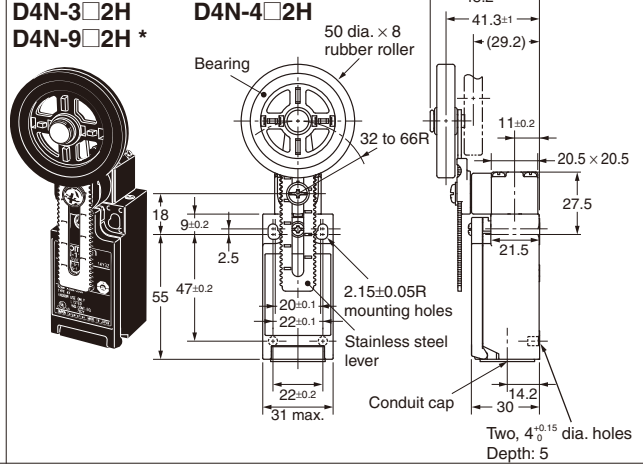

Note: Unless otherwise specified, a tolerance of ±0.4 mm applies to all dimensions.
* Refer to following diagrams for details on M12 connectors.

Snap-action (1NC/1NO) (2NC), Slow-action (2NC) (3NC)

Model		D4N-□12H D4N-□22H D4N-□B2H D4N-□D2H	D4N-□12G D4N-□22G D4N-□B2G D4N-□D2G *1
Operating characteristics			
Operating force	OF max.	4.5 N	
Release force	RF min.	0.4 N	
Pretravel	PT	18° to 27°	
Overtravel	OT min.	40°	
Movement differential	MD max. *2	14°	
Operating position	OP	---	
Total travel	TT *3	(80°)	
Direct opening travel	DOT min. *4	50°	
Direct opening force	DOF min. *4	20 N	

Note: Variation occurs in the simultaneity of contact opening/closing operations of 2NC, 2NC/1NO, and 3NC contacts. Check contact operation.
*1. The operating characteristics of these Switches were measured with the roller lever set at 32 mm.
*2. Only for snap-action models.
*3. Reference value.
*4. For safe use, always make sure that the minimum values or greater are provided.

Slow-action (1NC/1NO) (2NC/1NO)

Model		D4N-□A2H D4N-□C2H D4N-□E2H D4N-□F2H	D4N-□A2G D4N-□C2G D4N-□E2G D4N-□F2G *1
Operating characteristics			
Operating force	OF max.	4.5 N	
Release force	RF min.	0.4 N	
Pretravel	PT *2	18° to 27°	
	PT (2nd) *3	(44°)	
	PT *4	27.5° to 36.5°	
	PT (2nd) *5	(18°)	
Overtravel	OT min.	40°	
Operating position	OP	---	
Total travel	TT *6	(80°)	
Direct opening travel	DOT min.	50°	
Direct opening force	DOF min. *7	20 N	

*1. The operating characteristics of these Switches were measured with the roller lever set at 32 mm.
*2. This PT value is possible when the NC contacts are open (OFF).
*3. This PT value is possible when the NO contacts are closed (ON).
*4. Only for MBB models.
*5. Reference value for MBB models only.
*6. Reference value.
*7. For safe use, always make sure that the minimum values or greater are provided.

1-conduit M12 Connector
D4N-9□□□

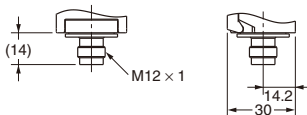

2-conduit Models

Roller Lever (Resin Lever, Resin Roller)

D4N-5□20
D4N-6□20
D4N-8□20

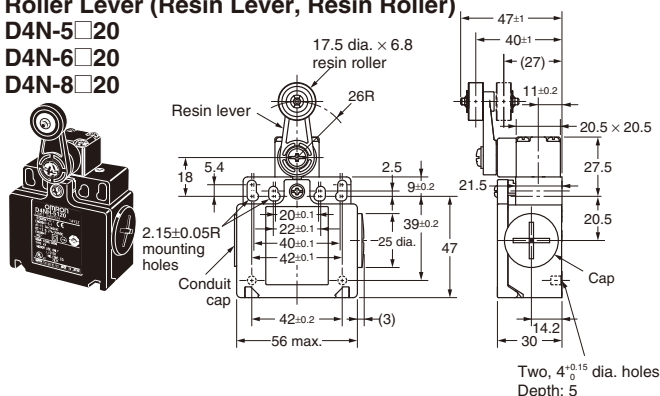

Roller Lever (Metal Lever, Resin Roller)

D4N-5□22
D4N-6□22
D4N-8□22

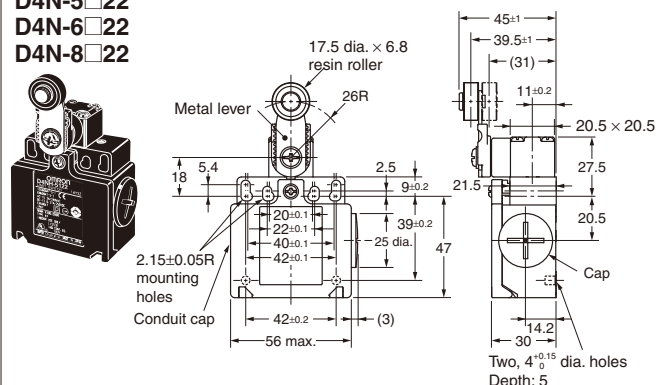

Plunger
D4N-5□31
D4N-6□31
D4N-8□31

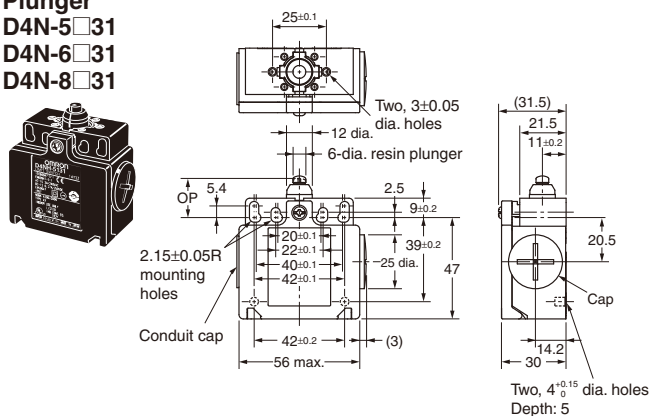

Roller Plunger

D4N-5□32
D4N-6□32
D4N-8□32

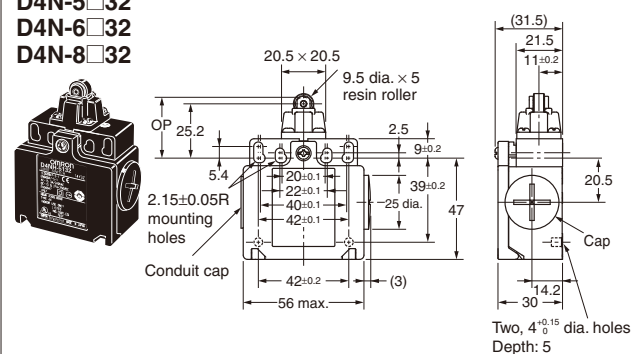

Note: Unless otherwise specified, a tolerance of ±0.4 mm applies to all dimensions.

Snap-action (1NC/1NO) (2NC), Slow-action (2NC) (3NC)

Model	D4N-□120	D4N-□122	D4N-□131	D4N-□132
	D4N-□220	D4N-□222	D4N-□231	D4N-□232
	D4N-□B20	D4N-□B22	D4N-□B31	D4N-□B32
	D4N-□D20	D4N-□D22	D4N-□D31	D4N-□D32
Operating characteristics				
Operating force	OF max.	5 N	5 N	6.5 N
Release force	RF min.	0.5 N	0.5 N	1.5 N
Pretravel	PT	18° to 27°	18° to 27°	2 mm
Overtravel	OT min.	40°	40°	4 mm
Movement differential	MD max.	14°	14°	1 mm
Operating position	OP	---	---	18 ±0.5 mm
Total travel	TT *2	(80°)	(80°)	(6 mm)
Direct opening travel	DOT min.	50°	50°	3.2 mm
Direct opening force	DOF min.	20 N	20 N	20 N

Note: Variation occurs in the simultaneity of contact opening/closing operations of 2NC, 2NC/1NO, and 3NC contacts. Check contact operation.

- *1. Only for snap-action models.
- *2. Reference value.
- *3. For safe use, always make sure that the minimum values or greater are provided.

Slow-action (1NC/1NO) (2NC/1NO)

Model	D4N-□A20	D4N-□A22	D4N-□A31	D4N-□A32
	D4N-□C20	D4N-□C22	D4N-□C31	D4N-□C32
	D4N-□E20	D4N-□E22	D4N-□E31	D4N-□E32
	D4N-□F20	D4N-□F22	D4N-□F31	D4N-□F32
Operating characteristics				
Operating force	OF max.	5 N	5 N	6.5 N
Release force	RF min.	0.5 N	0.5 N	1.5 N
Pretravel	PT *1	18° to 27°	18° to 27°	2 mm
	PT (2nd) *2	(44°)	(44°)	(2.9 mm)
	PT *3	27.5° to 36.5°	27.5° to 36.5°	2.8 mm
	PT (2nd) *4	(18°)	(18°)	(1 mm)
Overtravel	OT min.	40°	40°	4 mm
Operating position	OP	---	---	18 ±0.5 mm
	OP *5	---	---	17.4 ±0.5 mm
Total travel	TT *6	(80°)	(80°)	(6 mm)
Direct opening travel	DOT min.	50°	50°	3.2 mm
Direct opening force	DOF min.	20 N	20 N	20 N

- *1. This PT value is possible when the NC contacts are open (OFF).
- *2. This PT value is possible when the NO contacts are closed (ON).
- *3. Only for MBB models.
- *4. Reference value for MBB models.
- *5. Only for MBB models.
- *6. Reference value.
- *7. For safe use, always make sure that the minimum values or greater are provided.

2-conduit Models

One-way Roller Arm Lever (Horizontal)

D4N-5□62
D4N-6□62
D4N-8□62

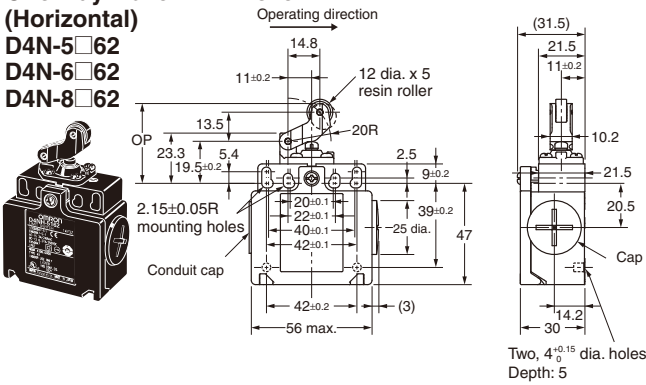

One-way Roller Arm Lever (Vertical)

D4N-5□72
D4N-6□72
D4N-8□72

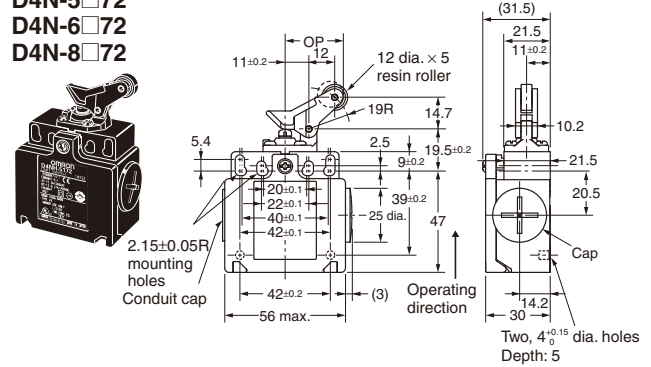

Adjustable Roller Lever, Form Lock (with Metal Lever, Resin Roller)

D4N-6□2G
D4N-8□2G

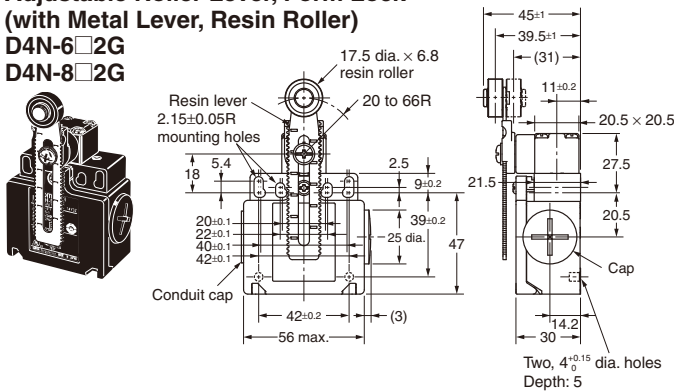

Adjustable Roller Lever, Form Lock (with Metal Lever, Rubber Roller)

D4N-6□2H
D4N-8□2H

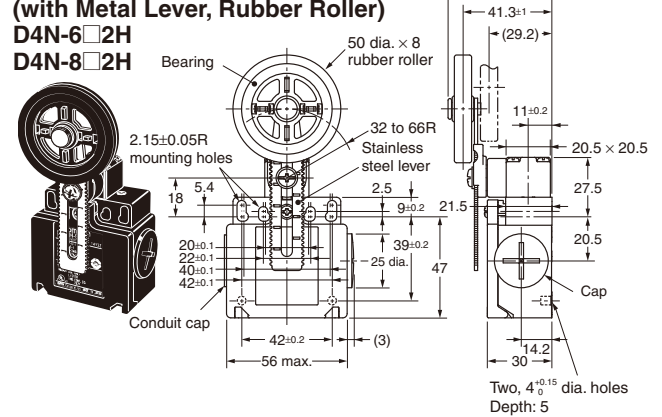

Note: Unless otherwise specified, a tolerance of ±0.4 mm applies to all dimensions.

Snap-action (1NC/1NO) (2NC), Slow-action (2NC) (3NC)

Model	D4N-□162	D4N-□172	D4N-□12G	D4N-□12H
Operating characteristics	D4N-□262	D4N-□272	D4N-□22G	D4N-□22H
Operating force	D4N-□B62	D4N-□B72	D4N-□B2G	D4N-□B2H
Release force	D4N-□D62	D4N-□D72	D4N-□D2G	D4N-□D2H
Pretravel			*1	*2
Overtravel				
Movement differential				
Operating position				
Total travel				
Direct opening travel				
Direct opening force				

Note: Variation occurs in the simultaneity of contact opening/closing operations of 2NC, 2NC/1NO, and 3NC contacts. Check contact operation.

- *1. The operating characteristics of these Switches were measured with the roller lever set at 30 mm.
- *2. The operating characteristics of these Switches were measured with the roller lever set at 31 mm.
- *3. Only for snap-action models.
- *4. Reference value.
- *5. For safe use, always make sure that the minimum values or greater are provided.

Slow-action (1NC/1NO) (2NC/1NO)

Model	D4N-□A62	D4N-□A72	D4N-□A2G	D4N-□A2H
Operating characteristics	D4N-□C62	D4N-□C72	D4N-□C2G	D4N-□C2H
Operating force	D4N-□E62	D4N-□E72	D4N-□E2G	D4N-□E2H
Release force	D4N-□F62	D4N-□F72	D4N-□F2G	D4N-□F2H
Pretravel			*1	*2
Overtravel				
Operating position				
Total travel				
Direct opening travel				
Direct opening force				

- *1. The operating characteristics of these Switches were measured with the roller lever set at 30 mm.
- *2. The operating characteristics of these Switches were measured with the roller lever set at 31 mm.
- *3. This PT value is possible when the NC contacts are open (OFF).
- *4. This PT value is possible when the NO contacts are closed (ON).
- *5. Only for MBB models.
- *6. Reference value for MBB models only.
- *7. Only for MBB models.
- *8. Reference value.
- *9. For safe use, always make sure that the minimum values or greater are provided.

2-conduit Models

Fork Lever Lock
(Right Operation)

D4N-5□RE D4N-6□RE
D4N-7□RE D4N-8□RE

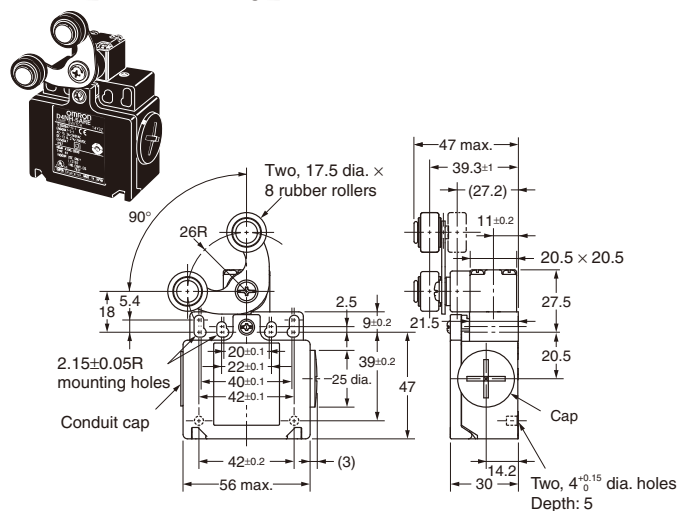

Fork Lever Lock
(Left Operation)

D4N-5□LE D4N-6□LE
D4N-7□LE D4N-8□LE

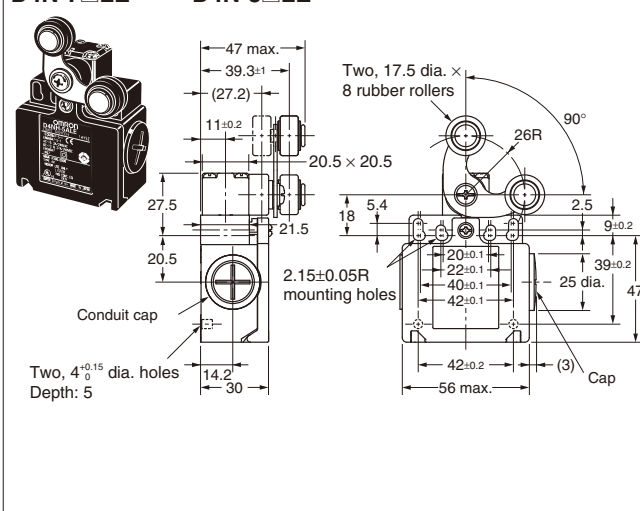

Cat Whisker

D4N-5□80 D4N-6□80
D4N-7□80 D4N-8□80

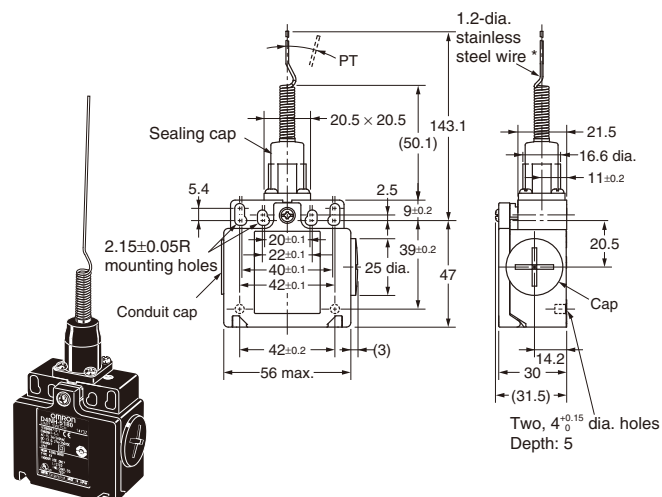

Plastic Rod

D4N-5□87 D4N-6□87
D4N-7□87 D4N-8□87

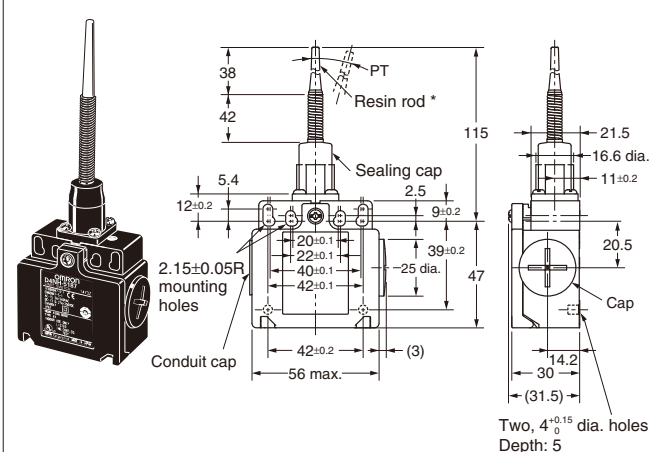

Note: Unless otherwise specified, a tolerance of ±0.4 mm applies to all dimensions.

*The usable range for stainless steel wires and resin rods is 35 mm max. from the end with a total travel of 70 mm max.

Slow-action (1NC/1NO) (2NC), Slow-action (2NC) (3NC)

Model	D4N-□□RE	D4N-□□LE
Operating characteristics		
Force necessary to reverse the direction of the lever: max.	6.4 N	6.4 N
Movement until the lever reverses	55 ±10°	55 ±10°
Movement until switch operation (NC)	(6.5°)	(6.5°) (MBB: 10°)
Movement until switch operation (NO)	(18.5°)	(18.5°) (MBB: 5°)

Note: Variation occurs in the simultaneity of contact opening/closing operations of 2NC, 2NC/1NO, and 3NC contacts. Check contact operation.

Snap-action (1NC/1NO), Slow-action (2NC) (3NC)

Model	D4N-□□80	D4N-□□87
Operating characteristics		
Operating force OF max.	1.5 N	1.5 N
Pretravel PT max.	15°	15°

Levers

Refer to the following for the angles and positions of the watchdogs (source: EN50047.)

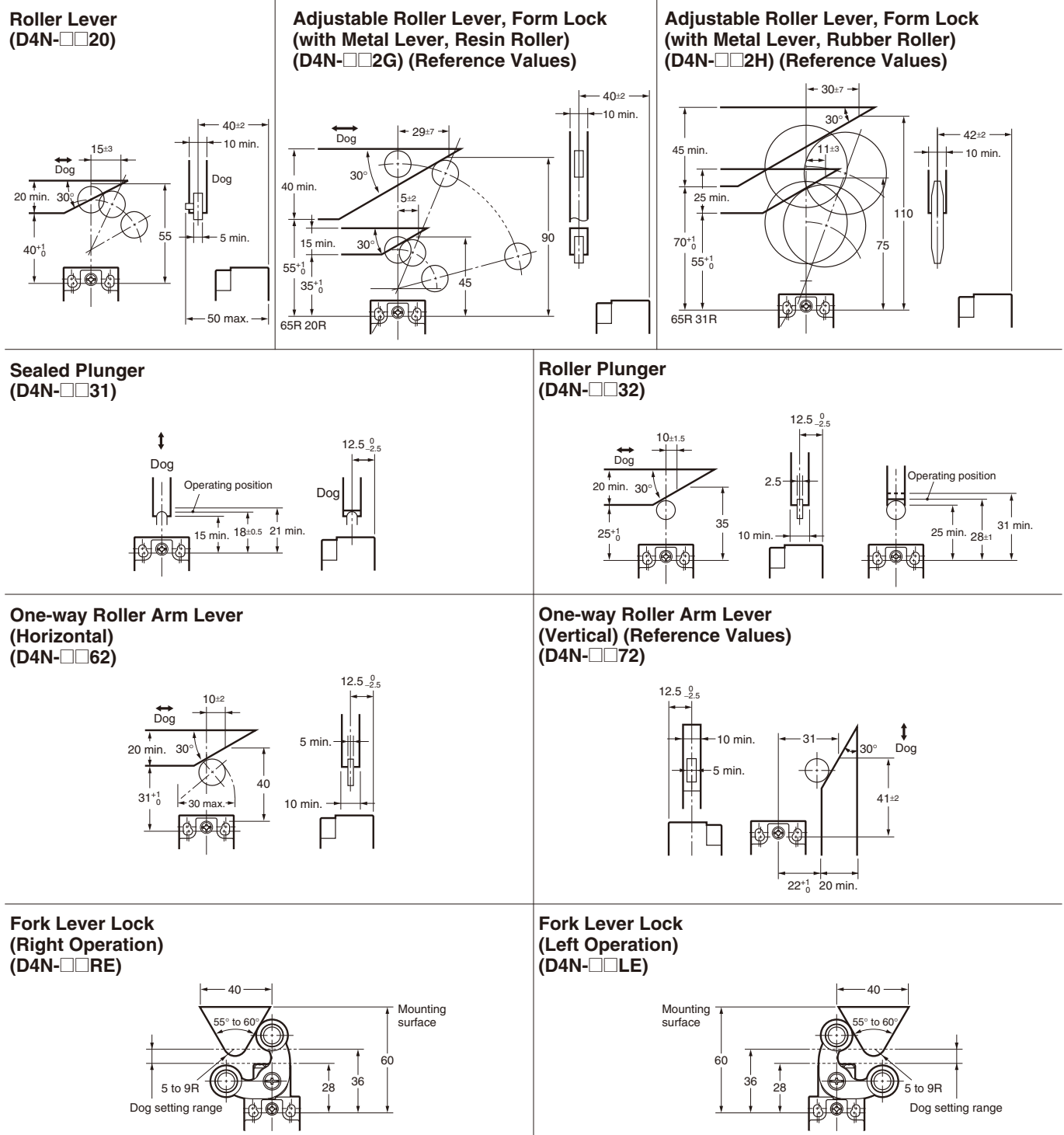

Note: Unless otherwise specified, a tolerance of ± 0.4 mm applies to all dimensions.

Safety Precautions

Refer to the “*Precautions for All Switches*” and “*Precautions for All Safety Limit Switches*”.

CAUTION

Electric shock may occasionally occur.
Do not use metal connectors or metal conduits.



Precautions for Safe Use

- Do not use the Switch submerged in oil or water, or in locations continuously subject to splashes of oil or water. Doing so may result in oil or water entering the Switch interior. (The IP67 degree of protection specification for the Switch refers to water penetration while the Switch is submersed in water for a specified period of time.)
- Always attach the cover after completing wiring and before using the Switch. Also, do not turn ON the Switch with the cover open. Doing so may result in electric shock.
- Do not switch circuits for two or more standard loads (250 VAC, 3 A) at the same time. Doing so may adversely affect insulation performance.

Precautions for Correct Use

The Switch contacts can be used with either standard loads or microloads. Once the contacts have been used to switch a load, however, they cannot be used to switch smaller loads. The contact surfaces will become rough once they have been used and contact reliability for smaller loads may be reduced.

Mounting Method

Appropriate Tightening Torque

Tighten each of the screws to the specified torque. Loose screws may result in malfunction of the Switch within a short time.

1	Terminal screw	0.6 to 0.8 N·m
2	Cover mounting screw	0.5 to 0.7 N·m
3	Head mounting screw	0.5 to 0.6 N·m
4	Lever mounting screw	1.6 to 1.8 N·m
5	Body mounting screw	0.5 to 0.7 N·m
6	Connector, M12 adaptor	1.8 to 2.2 N·m (except 1/2-14NPT) 1.4 to 1.8 N·m (for 1/2-14NPT)
7	Cap screw	1.3 to 1.7 N·m

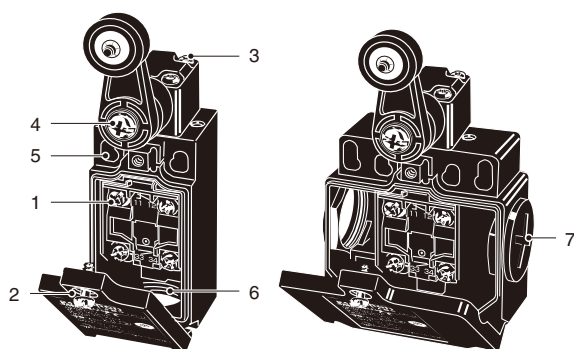

Switch Mounting

- Mount the Switch using M4 screws and washers and tighten the screws to the specified torque.
- For safety, use screws that cannot be easily removed, or use an equivalent measure to ensure that the Switch is secure.
- As shown below, two studs with a maximum height of 4.8 mm and a diameter of $4_{-0.05}^{+0.15}$ mm can be provided, the studs inserted into the holes on the bottom of the Switch, and the Switch secured at four locations to increase the mounting strength.

Switch Mounting Holes

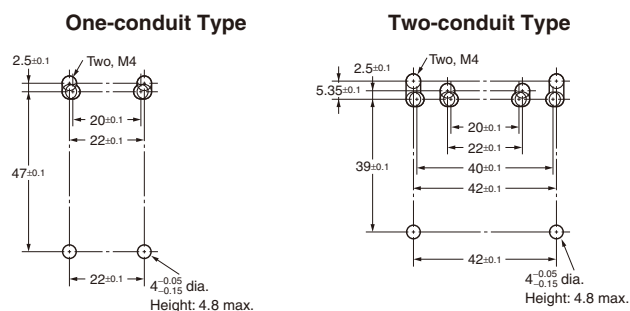

- Make sure that the dog contacts the actuator at a right angle. Applying a load to the switch actuator (roller) on a slant may result in deformation or damage of the actuator or rotary shaft.

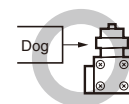

Incorrect

Correct

Wiring

Wiring

- When connecting to the terminals via insulating tube and M3.5 crimp terminals, arrange the crimp terminals as shown below so that they do not rise up onto the case or the cover. Applicable lead wire size: AWG20 to AWG18 (0.5 to 0.75 mm²). Use lead wires of an appropriate length, as shown below. Not doing so may result in excess length causing the cover to rise and not fit properly.

One-conduit Type (3 Poles)

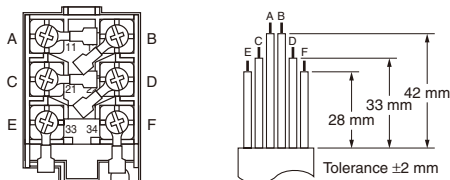

Two-conduit Type (3 Poles)

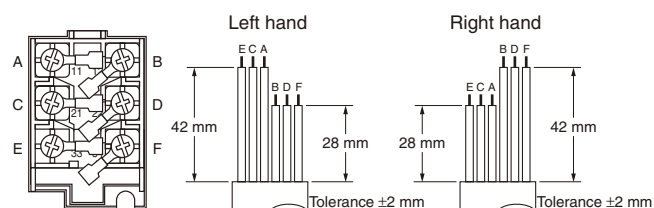

- Do not push crimp terminals into gaps in the case interior. Doing so may cause damage or deformation of the case.
- Use crimp terminals not more than 0.5 mm in thickness. Otherwise, they will interfere with other components inside the case.

[Reference] The crimp terminals shown below are not more than 0.5 mm thick.

Manufacturer	Type
J.S.T. Mfg. Co.	FN0.5-3.7 (F Type)
	N0.5-3.7 (Straight Type)

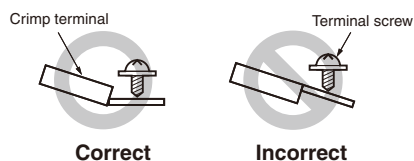
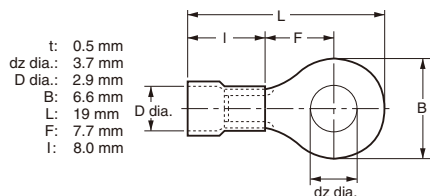

Contact Arrangement

- The contact arrangements are shown below.

Screw Terminal Type

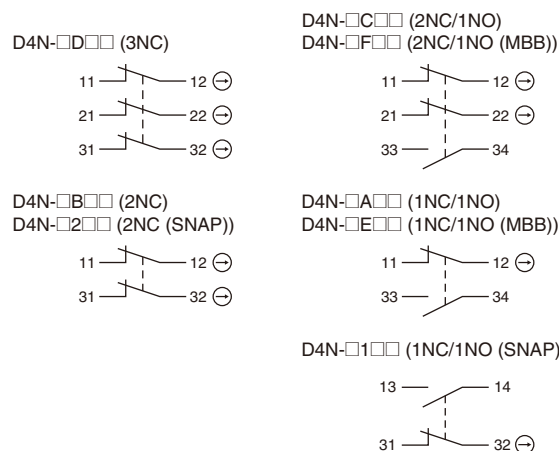

Connector Type

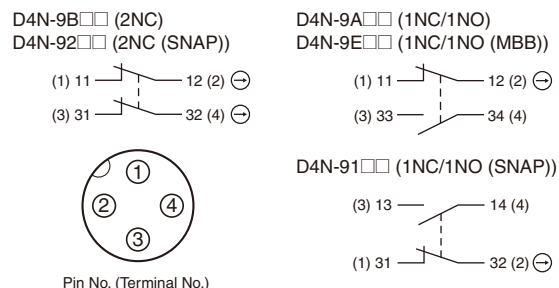

- Applicable socket: XS2F (OMRON).
- Refer to the *Connector Catalog* for details on socket pin numbers and lead wire colors.

Socket Tightening (Connector Type)

- Turn the socket connector screws by hand and tighten until no space remains between the socket and the plug.
- Make sure that the socket connector is tightened securely. Otherwise, the rated degree of protection (IP67) may not be maintained and vibration may loosen the socket connector.

Conduit Opening

- Connect a recommended connector to the opening of the conduit and tighten the connector to the specified torque. The case may be damaged if an excessive tightening torque is applied.
- When using 1/2-14NPT, wind sealing tape around the joint between the connector and conduit opening so that the enclosure will conform to IP67.
- Use a cable with a suitable diameter for the connector.
- Attach and tighten a conduit cap to the unused conduit opening when wiring. Tighten the conduit cap to the specified torque. The conduit cap is provided with the Switch (2-conduit types).

Changing the Lever

The lever mounting screws can be used to set the lever position to any position in a 360° angle at 7.5° increments. Grooves are incised on the lever and rotary shaft that engage to prevent the lever from slipping against the rotary shaft. The screws on adjustable roller lever models can also loosened to change the length of the lever. Remove the screws from the front of the lever before mounting the lever in reverse (front/back), and set the level so that operation will be completed before exceeding a range of 180° on the horizontal.

Recommended Connectors

Use connectors with screws not exceeding 9 mm, otherwise the screws will protrude into the case interior, interfering with other components in the case.

The connectors listed in the following table have connectors with thread sections not exceeding 9 mm.

Use the recommended connectors to ensure conformance to IP67.

Size	Manufacturer	Model	Applicable cable diameter
G1/2	LAPP	ST-PF1/2 5380-1002	6.0 to 12.0 mm
Pg13.5	LAPP	ST-13.5 5301-5030	6.0 to 12.0 mm
M20	LAPP	ST-M20 × 1.5 5311-1020	7.0 to 13.0 mm
1/2-14NPT	LAPP	ST-NPT1/2 5301-6030	6.0 to 12.0 mm

Use LAPP connectors together with seal packing (JPK-16, GP-13.5, or GPM20), and tighten to the specified tightening torque. Seal packing is sold separately.

- LAPP is a German manufacturer.
- Before using a 2-conduit 1/2-14NPT type, attach the provided changing adaptor to the Switch and then connect the recommended connector.

Others

- When attaching a cover, be sure that the seal rubber is in place and that there is no foreign material present. If the cover is attached with the seal rubber out of place or if foreign material is stuck to the rubber, a proper seal will not be obtained.
- Do not use any screws to connect the cover other than the specified ones. The seal characteristics may be reduced.
- Make sure that foreign particles do not enter the head when removing the screws from the four corners to change the head position in any of the four directions.
- Use the following recommended countermeasures to prevent telegraphing when using adjustable or long levers.
 1. Make the rear edge of the dog smooth with an angle of 15° to 30° or make it in the shape of a quadratic curve.
 2. Design the circuit so that no error signal will be generated.

Production Discontinuation

Following the release of the D4N, production of the D4D-N was discontinued.

Date of Production Discontinuation

Production of the D4D-N Series was discontinued as of the end of March 2006.

Recommended Substitute Product

Sales of the D4N series commenced in January 2004.

Product Substitution

1. Dimensions

The D4D-N and D4N use the same mounting method, and mounting hole. The multi-contact structure and the extra 4 mm in length, however, are different.

2. Terminal Numbers

For the 2-contact slow-action model, the terminals 21, 22, 23, and 24 on the D4D-N are 31, 32, 33, and 34 on the D4N.

3. Recommended Terminals

If the recommended terminals are not used, the Switch may not be compatible. Make sure that the Switch is compatible with the terminals.

Comparison with Discontinued Products

Item	Model	D4N
Switch color		Very similar
Dimensions		Very similar
Wiring/connection		Significantly different
Mounting method		Completely compatible
Ratings/performance		Very similar
Operating characteristics		Very similar
Operating method		Completely compatible

Dimensions (Unit: mm)

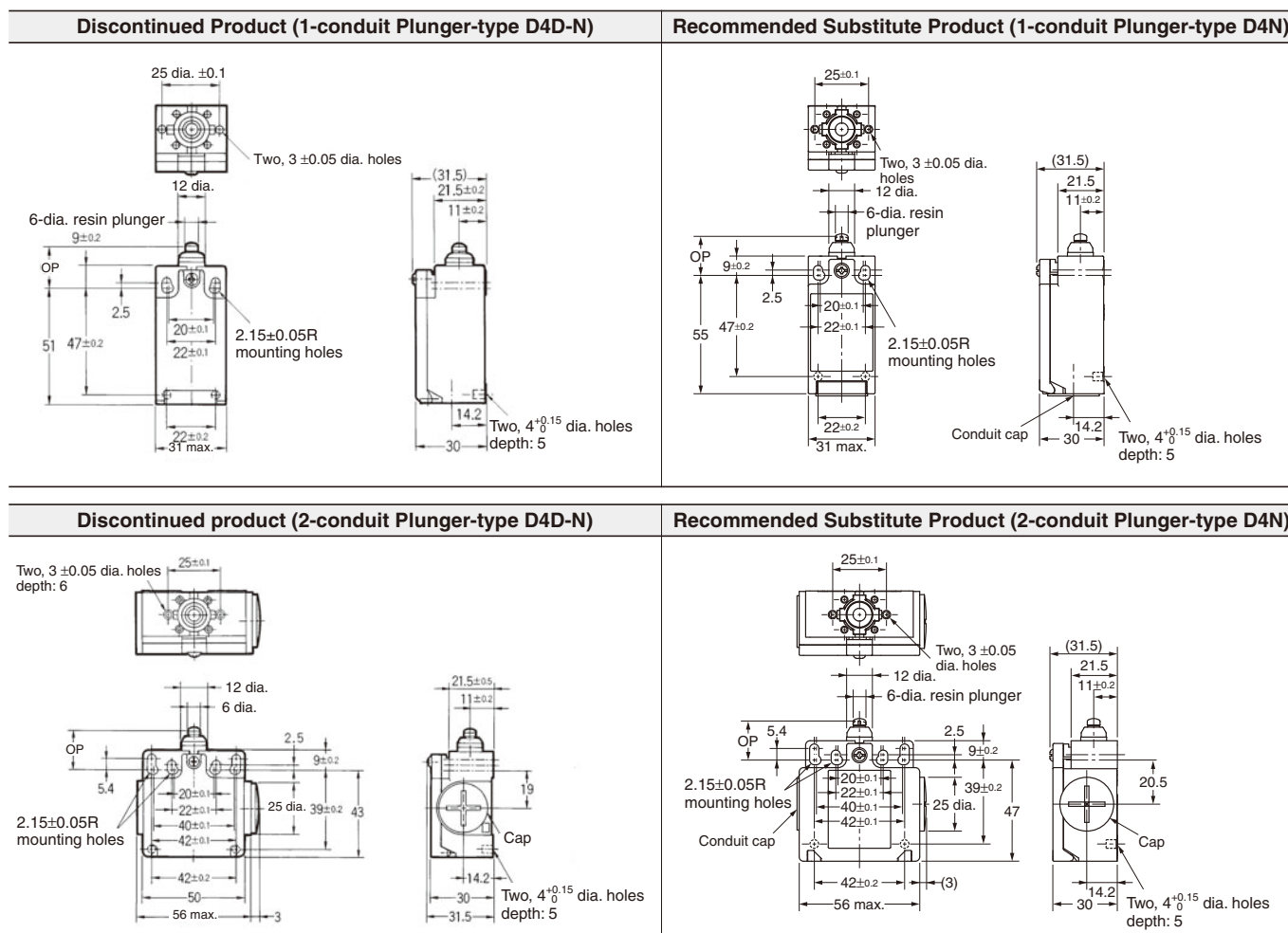

List of Recommended Substitute Products

■ : The actuator on the D4D-N is a non-safety type. The D4N is recommended for safety applications (form lock type). Be sure to mount it correctly.

■ : M screws are recommended to comply with European standards. Therefore, the M20 type is recommended as a substitute when the Pg13.5 conduit-type is not available in a D4N model.

Safety Limit Switches

Discontinued product	Recommended substitute product
D4D-1120N	D4N-1120
D4D-2120N	D4N-2120
D4D-3120N	D4N-3120
D4D-5120N	D4N-5120
D4D-6120N	D4N-6120
D4D-1122N	D4N-1122
D4D-2122N	D4N-2122
D4D-3122N	D4N-3122
D4D-5122N	D4N-5122
D4D-6122N	D4N-6122
D4D-1125N	D4N-1125
D4D-2125N	D4N-2125
D4D-3125N	D4N-3125
D4D-1131N	D4N-1131
D4D-2131N	D4N-2131
D4D-3131N	D4N-3131
D4D-5131N	D4N-5131
D4D-6131N	D4N-6131
D4D-1132N	D4N-1132
D4D-2132N	D4N-2132
D4D-3132N	D4N-3132
D4D-5132N	D4N-5132
D4D-6132N	D4N-6132
D4D-1162N	D4N-1162
D4D-2162N	D4N-2162
D4D-3162N	D4N-3162
D4D-5162N	D4N-5162
D4D-6162N	D4N-6162
D4D-1172N	D4N-1172
D4D-2172N	D4N-2172
D4D-3172N	D4N-3172
D4D-5172N	D4N-5172
D4D-6172N	D4N-6172
D4D-112HN	D4N-112H
D4D-212HN	D4N-212H
D4D-312HN	D4N-312H

Discontinued product	Recommended substitute product
D4D-1520N	D4N-1A20
D4D-2520N	D4N-2A20
D4D-3520N	D4N-3A20
D4D-5520N	D4N-5A20
D4D-6520N	D4N-6A20
D4D-1522N	D4N-1A22
D4D-2522N	D4N-2A22
D4D-3522N	D4N-3A22
D4D-5522N	D4N-5A22
D4D-6522N	D4N-6A22
D4D-1525N	D4N-1A25
D4D-2525N	D4N-2A25
D4D-3525N	D4N-3A25
D4D-1531N	D4N-1A31
D4D-2531N	D4N-2A31
D4D-3531N	D4N-3A31
D4D-5531N	D4N-5A31
D4D-6531N	D4N-6A31
D4D-1532N	D4N-1A32
D4D-2532N	D4N-2A32
D4D-3532N	D4N-3A32
D4D-5532N	D4N-5A32
D4D-6532N	D4N-6A32
D4D-1562N	D4N-1A62
D4D-2562N	D4N-2A62
D4D-3562N	D4N-3A62
D4D-5562N	D4N-5A62
D4D-6562N	D4N-6A62
D4D-1572N	D4N-1A72
D4D-2572N	D4N-2A72
D4D-3572N	D4N-3A72
D4D-5572N	D4N-5A72
D4D-6572N	D4N-6A72
D4D-152HN	D4N-1A2H
D4D-252HN	D4N-2A2H
D4D-352HN	D4N-3A2H

Discontinued product	Recommended substitute product
D4D-1A20N	D4N-1B20
D4D-2A20N	D4N-2B20
D4D-3A20N	D4N-3B20
D4D-5A20N	D4N-5B20
D4D-6A20N	D4N-6B20
D4D-1A22N	D4N-1B22
D4D-2A22N	D4N-2B22
D4D-3A22N	D4N-3B22
D4D-5A22N	D4N-5B22
D4D-6A22N	D4N-6B22
D4D-1A25N	D4N-1B25
D4D-2A25N	D4N-2B25
D4D-3A25N	D4N-3B25
D4D-1A31N	D4N-1B31
D4D-2A31N	D4N-2B31
D4D-3A31N	D4N-3B31
D4D-5A31N	D4N-5B31
D4D-6A31N	D4N-6B31
D4D-1A32N	D4N-1B32
D4D-2A32N	D4N-2B32
D4D-3A32N	D4N-3B32
D4D-5A32N	D4N-5B32
D4D-6A32N	D4N-6B32
D4D-1A62N	D4N-1B62
D4D-2A62N	D4N-2B62
D4D-3A62N	D4N-3B62
D4D-5A62N	D4N-5B62
D4D-6A62N	D4N-6B62
D4D-1A72N	D4N-1B72
D4D-2A72N	D4N-2B72
D4D-3A72N	D4N-3B72
D4D-5A72N	D4N-5B72
D4D-6A72N	D4N-6B72
D4D-1A2HN	D4N-1B2H
D4D-2A2HN	D4N-2B2H
D4D-3A2HN	D4N-3B2H

General-purpose Limit Switches

Discontinued product	Recommended substitute product
D4D-1121N	D4N-112G
D4D-2121N	D4N-212G
D4D-3121N	D4N-312G
D4D-5121N	D4N-512G
D4D-6121N	D4N-612G
D4D-1127N	D4N-112H
D4D-2127N	D4N-212H
D4D-3127N	D4N-312H
D4D-5127N	D4N-512H
D4D-6127N	D4N-612H
D4D-1180N	D4N-4180
D4D-2180N	D4N-2180
D4D-3180N	D4N-3180
D4D-5180N	D4N-8180
D4D-6180N	D4N-6180
D4D-1187N	D4N-4187
D4D-2187N	D4N-2187
D4D-3187N	D4N-3187
D4D-5187N	D4N-8187
D4D-6187N	D4N-6187

Discontinued product	Recommended substitute product
D4D-15REN	D4N-1ARE
D4D-25REN	D4N-2ARE
D4D-35REN	D4N-3ARE
D4D-55REN	D4N-5ARE
D4D-65REN	D4N-6ARE
D4D-15LEN	D4N-1ALE
D4D-25LEN	D4N-2ALE
D4D-35LEN	D4N-3ALE
D4D-55LEN	D4N-5ALE
D4D-65LEN	D4N-6ALE
D4D-1521N	D4N-1A2G
D4D-2521N	D4N-2A2G
D4D-3521N	D4N-3A2G
D4D-5521N	D4N-5A2G
D4D-6521N	D4N-6A2G
D4D-1527N	D4N-1A2H
D4D-2527N	D4N-2A2H
D4D-3527N	D4N-3A2H
D4D-5527N	D4N-5A2H
D4D-6527N	D4N-6A2H

Discontinued product	Recommended substitute product
D4D-1AREN	D4N-1BRE
D4D-2AREN	D4N-2BRE
D4D-3AREN	D4N-3BRE
D4D-5AREN	D4N-5BRE
D4D-6AREN	D4N-6BRE
D4D-1ALEN	D4N-1BLE
D4D-2ALEN	D4N-2BLE
D4D-3ALEN	D4N-3BLE
D4D-5ALEN	D4N-5BLE
D4D-6ALEN	D4N-6BLE
D4D-1A21N	D4N-1B2G
D4D-2A21N	D4N-2B2G
D4D-3A21N	D4N-3B2G
D4D-5A21N	D4N-5B2G
D4D-6A21N	D4N-6B2G
D4D-1A27N	D4N-1B2H
D4D-2A27N	D4N-2B2H
D4D-3A27N	D4N-3B2H
D4D-5A27N	D4N-5B2H
D4D-6A27N	D4N-6B2H
D4D-1A80N	D4N-4B80
D4D-2A80N	D4N-2B80
D4D-3A80N	D4N-3B80
D4D-5A80N	D4N-8B80
D4D-6A80N	D4N-6B80
D4D-1A87N	D4N-4B87
D4D-2A87N	D4N-2B87
D4D-3A87N	D4N-3B87
D4D-5A87N	D4N-8B87
D4D-6A87N	D4N-6B87

Precautions for All Safety Limit Switches

Note: Refer to the “*Safety Precautions*” section for each Switch for specific precautions applicable to each Switch.

Precautions for Safe Use

- Do not use the Switch in atmospheres containing explosive or flammable gases.
- Although the switch box is protected from dust or water penetration, the head is not protected from minute foreign matter or water penetration. Ensure that minute foreign matter and water do not penetrate the head. Failure to do so may result in accelerated wear, Switch damage, or malfunctioning.
- The durability of the Switch varies considerably depending on the switching conditions. Always confirm the usage conditions by using the Switch in an actual application, and use the Switch only for the number of switching operations that its performance allows.
- Do not use the Switch as a stopper.
- Do not use the Switch in a startup circuit. Use it instead for a safety confirmation signal.
- Check the Switches before use and inspect regularly, replacing them when necessary. If a Switch is kept pressed for an extended period of time, the components may deteriorate quickly, and the Switch may not release.
- To protect the Switch from damage due to short-circuits, be sure to connect a quick-response fuse with a breaking current 1.5 to 2 times larger than the rated current in series with the Switch. When complying with EN certified ratings, use a 10 A IEC 60269-compliant gI or gG fuse.
- Do not drop the Switch. Doing so may prevent it from functioning to its full capacity.
- Do not disassemble or modify the Switch. Doing so may prevent it from operating correctly.

Precautions for Correct Use

Mechanical Characteristics

Operating Force, Stroke, and Contact Characteristics

- The following graph indicates the relationship between operating force and stroke or stroke and contact force. In order to operate the Limit Switch with high reliability, it is necessary to use the Limit Switch within an appropriate contact force range. If the Limit Switch is used in the normally closed condition, the dog must be installed so that the actuator will return to the FP when the actuator is actuated by the object. If the Limit Switch is used in the normally open condition, the actuator must be pressed to 80% to 100% of the OT (i.e., 60% to 80% of the TT) and any slight fluctuation must be absorbed by the actuator.
- If the full stroke is set close to the OP or RP, contact instability may result. If the full stroke is set to the TTP, the actuator or switch may become damaged due to the inertia of the dog. In that case, adjust the stroke with the mounting panel or the dog. Refer to page C-2, *Dog Design*, page C-3, *Stroke Settings vs. Dog Movement Distance*, and page C-3, *Dog Surface* for details.
- The following graph shows an example of changes in contact force according to the stroke. The contact force near the OP or RP is unstable, and the Limit Switch cannot maintain high reliability. Furthermore, the Limit Switch cannot withstand strong vibration or shock.

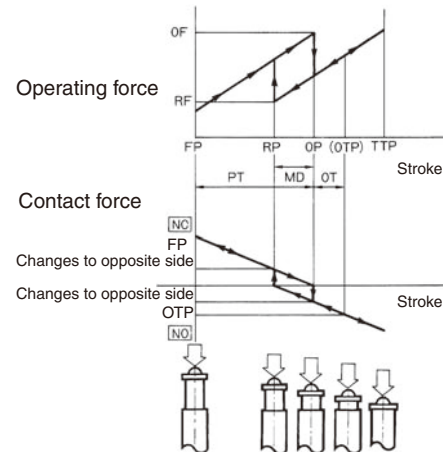

- If the Limit Switch is used so that the actuator is constantly pressed, it will fail quickly and reset faults may occur. Inspect the Limit Switch periodically and replace it as required.

Operation

- Carefully determine the proper cam or dog so that the actuator will not abruptly snap back, thus causing shock. In order to operate the Limit Switch at a comparatively high speed, use a cam or dog with a long enough stroke that keeps the Limit Switch turned ON for a sufficient time so that the relay or valve will be sufficiently energized.
- The operating method, the shape of the dog or cam, the operating frequency, and the travel after operation have a large influence on the durability and operating accuracy of the Limit Switch. The cam must be smooth in shape.

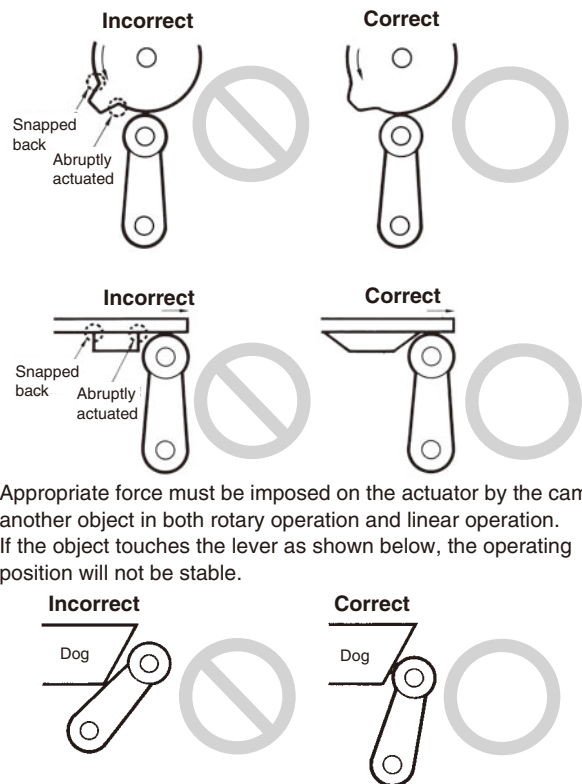

- Appropriate force must be imposed on the actuator by the cam or another object in both rotary operation and linear operation. If the object touches the lever as shown below, the operating position will not be stable.

- Unbalanced force must not be imposed on the actuator. Otherwise, wear and tear on the actuator may result.

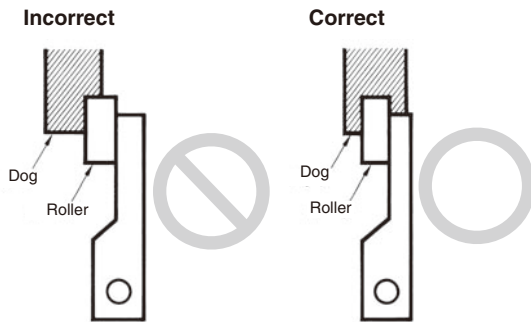

- Make sure that the actuator does not exceed the OT (overtravel) range, otherwise the Limit Switch may malfunction. When mounting the Limit Switch, be sure to adjust the Limit Switch carefully while considering the whole movement of the actuator.

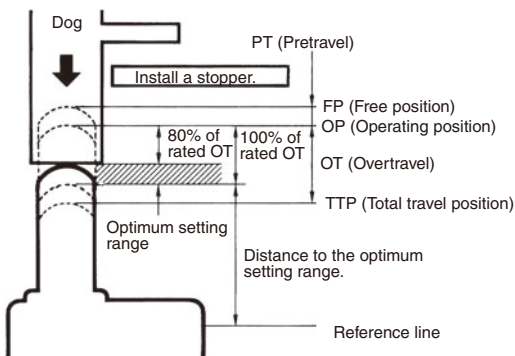

- The Limit Switch may soon malfunction if the OT is excessive. Therefore, adjustments and careful consideration of the position of the Limit Switch and the expected OT of the actuator are necessary when mounting the Limit Switch.

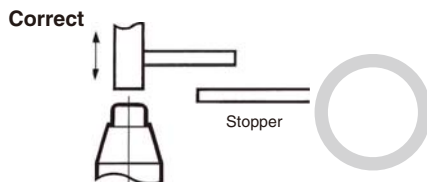

- Be sure to use the Limit Switch according to the characteristics of the actuator. If a roller arm lever actuator is used, do not attempt to actuate the Limit Switch in the direction shown below.



- Do not modify the actuator to change the OP.
- In the case of a long actuator of an adjustable roller lever type, the following countermeasures against lever shaking are recommended.

1. Make the rear edge of the object smooth with an angle of 15° to 30° or make it in the shape of a quadratic curve.
2. Design the circuit so that no error signal will be generated.
3. Use or set a switch that is actuated in one direction only. (Also, set the switch for operation in one direction only.)

Operating Environment

- These Switches are for indoor applications. The Switches may fail if they are used outdoors.
- Do not use the Switch in locations where toxic gases, such as H₂S, SO₂, NH₃, HNO₃, and Cl₂, may be present, or in locations that are subject to high temperatures or humidity. Doing so may damage the Switch due to contact failure or corrosion.
- Do not use the Switches in the following locations.
 - Locations subject to severe temperature changes
 - Locations subject to high temperatures or condensation
 - Locations subject to severe vibration
 - Locations where the interior of the Protective Door may come into direct contact with cutting chips, metal filings, oil, or chemicals
 - Locations where the Switch may come into contact with thinner or detergents
 - Locations where explosive or flammable gases are present

Switch Contacts

Switch contacts can be used with both standard loads and microloads, but once a contact has been used to switch a standard load, it cannot be used for a load of a smaller capacity. Doing so may result in roughening of the contact surface and contact reliability may be lost.

Storing Switches

Do not store the Switch in locations where toxic gases, such as H₂S, SO₂, NH₃, HNO₃, and Cl₂, may be present, or in locations that are subject to, excessive dirt, excessive dust, high temperature, or high humidity.

Other Precautions

- When attaching a cover, be sure that the seal rubber is in place and that there is no foreign material present. If the cover is attached with the seal rubber out of place or if foreign material is stuck to the rubber, a proper seal will not be obtained.
- Perform maintenance inspections periodically.
- Use the Switch with a load current that does not exceed the rated current.
- Do not use any screws to connect the cover other than the specified ones. The seal characteristics may be reduced.

Dog Design

Operating Speed, Dog Angle, and Relationship with Actuator

Before designing a dog, carefully consider the operating speed and angle of the dog and their relationship with the shape of the actuator. The optimum operating speed (V) of a standard dog at an angle of 30° to 45° is 0.5 m/s maximum.

Roller Lever Models

1. Non-overtravel Dog

Dog speed: 0.5 m/s max. (Standard Speed)

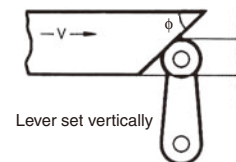

ϕ	V max. (m/s)	y
30°	0.4	0.8 (TT) 80% of totaltravel
45°	0.25	
60°	0.1	
60° to 90°	0.05 (low speed)	

Dog speed: 0.5 m/s ≤ V ≤ 2 m/s (High Speed)

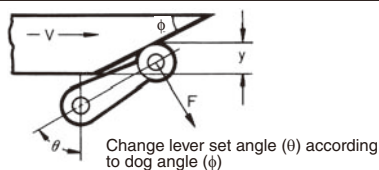

θ	ϕ	V max. (m/s)	y
45°	45°	0.5	0.5 to 0.8 (TT)
50°	40°	0.6	
60° to 55°	30° to 35°	1.3	0.5 to 0.7 (TT)
75° to 65°	15° to 25°	2	

Note: The above y values indicate the ratio ranges based on TT (total travel). Therefore, the optimum pressing distance of the dog is between 50% and 80% (or 50% and 70%).

2. Overtravel Dog

Dog speed: 0.5 m/s max.

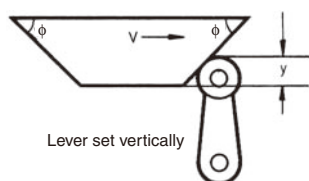

ϕ	V max. (m/s)	y
30°	0.4	0.8 (TT) 80% of total travel
45°	0.25	
60°	0.1	
60° to 90°	0.05 (low speed)	

Dog speed: 0.5 m/s min.

If the speed of the overtravel dog is comparatively high, make the rear edge of the object smooth at an angle of 15° to 30° or make it in the shape of a quadratic curve. Then lever shaking will be reduced.

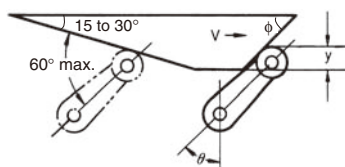

θ	ϕ	V max. (m/s)	y
45°	45°	0.5	0.5 to 0.8 (TT)
50°	40°	0.6	
60° to 55°	30° to 35°	1.3	0.5 to 0.7 (TT)
75° to 65°	15° to 25°	2	

Note: The above y values indicate the ratio ranges based on TT (total travel). Therefore, the optimum pressing distance of the dog is between 50% and 80% (or 50% and 70%).

Plunger Models

If the dog overrides the actuator, the front and rear of the dog may be the same in shape, provided that the dog is not designed to be separated from the actuator abruptly.

Roller Plunger

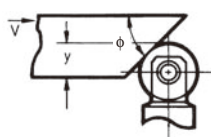

ϕ	V max. (m/s)	y
30°	0.25	0.6 to 0.8 (TT)
20°	0.5	0.5 to 0.7 (TT)

Stroke Settings vs. Dog Movement Distance

- The following provides information on stroke settings based on the movement distance of the dog instead of the actuator angle. The following is the optimum stroke of the Limit Switch.

Optimum stroke: $PT + \{\text{Rated OT} \times (0.7 \text{ to } 1.0)\}$
 The angle converted from the above: $\theta_1 + \theta_2$

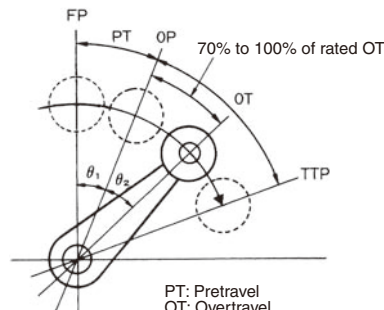

- The movement distance of the dog based on the optimum stroke is expressed by the following formula.

Movement distance of dog

$$X = R \sin \theta + \frac{R(1 - \cos \theta)}{\tan \phi} \text{ (mm)}$$

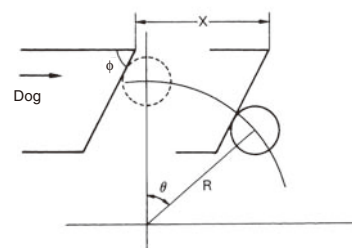

ϕ : Dog angle
 θ : Optimum stroke angle
 R: Actuator length
 X: Dog movement distance

- The distance between the reference line and the bottom of the dog based on the optimum stroke is expressed by the following formula.

$$Y = a + b + r \text{ (mm)}$$

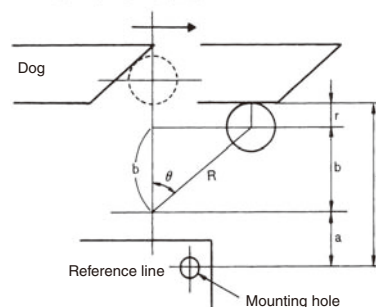

a: Distance between reference line and actuator fulcrum
 b: $R \cos \theta$
 r: Roller radius
 Y: Distance between reference line and bottom of dog

Dog Surface

- The surface of dog touching the actuator should be 6.3 S in quality and hardened at approximately HV450. For smooth operation of the actuator, apply molybdenum disulfide grease to the actuator and the dog touching the actuator.

Others

- When using the Limit Switch with a long lever or long rod lever, make sure that the lever is in the downward direction.

- With a roller actuator, the dog must touch the actuator at a right angle. The actuator or roller may deform or break if the dog touches the actuator (roller) at an oblique angle.

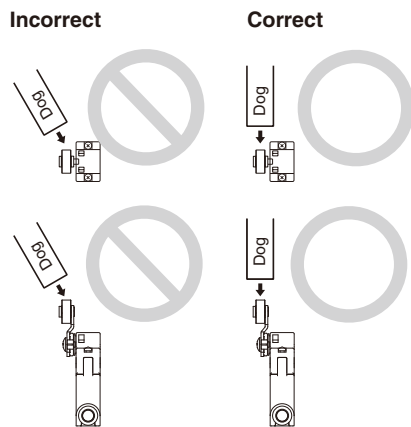

- Do not remove the Head. The Switch may fail.

Precautions for All Switches

Refer to the Safety *Precautions* section for each Switch for specific precautions applicable to each Switch.

Precautions for Safe Use

- If the Switch is to be used as a switch in an emergency stop circuit or in a safety circuit for preventing accidents resulting in injuries or deaths, use a Switch with a direct opening mechanism, use the NC contacts with a forced release mechanism, and set the Switch so that it will operate in direct opening mode.
For safety, install the Switch using one-way rotational screws or other similar means to prevent it from easily being removed. Protect the Switch with an appropriate cover and post a warning sign near the Switch to ensure safety.
- Do not perform wiring while power is being supplied. Wiring while the power is being supplied may result in electric shock.
- Keep the electrical load below the rated value.
- Be sure to evaluate the Switch under actual working conditions after installation.
- Do not touch the charged Switch terminals while the Switch has carry current, otherwise an electric shock may be received.
- If the Switch has a ground terminal, be sure to connect the ground terminal to a ground wire.
- The durability of the Switch greatly varies with switching conditions. Before using the Switch, be sure to test the Switch under actual conditions. Make sure that the number of switching operations is within the permissible range.
If a deteriorated Switch is used continuously, insulation failures, contact welding, contact failures, Switch damage, or Switch burnout may result.
- Maintain an appropriate insulation distance between wires connected to the Switch.
- Some types of load have a great difference between normal current and inrush current. Make sure that the inrush current is within the permissible value. The greater the inrush current in the closed circuit is, the greater the contact abrasion or shift will be. Consequently, contact welding, contact separation failures, or insulation failures may result. Furthermore, the Switch may become broken or damaged.

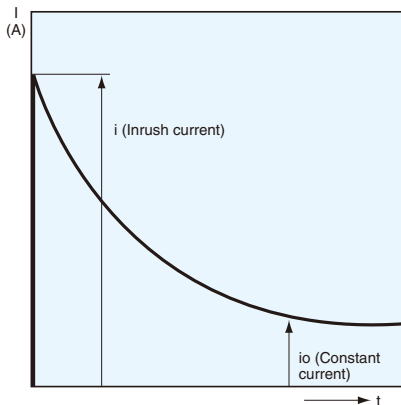

- The user must not attempt to repair or maintain the Switch and must contact the machine manufacturer for any repairs or maintenance.
- Do not attempt to disassemble or modify the Switch. Doing so may cause the Switch to malfunction.
- Do not drop the Switch. Doing so may result in the Switch not performing to its full capability.

Wiring

Pay the utmost attention so that each terminal is wired correctly. If the terminal is wired incorrectly, the Switch will not function. Furthermore, not only will the Switch have a negative influence on the external circuit, the Switch itself may become damaged or burnt.

Mounting

- Do not modify the Actuator, otherwise the operating characteristics and performance of the Actuator will change.
- Do not enlarge the mounting holes of the Switch or modify the Switch, otherwise insulation failures, housing damage, or human accidents may result.
- Do not apply oil, grease, or other lubricants to the moving parts of the Actuator, otherwise the Actuator may not operate correctly. Furthermore, ingress of oil, grease, or other lubricants inside the Switch may reduce sliding characteristic or cause failures in the Switch.
- Mount the Switch and secure it with the specified screws tightened to the specified torque along with flat and spring washers.
- Be sure to wire the Switch so that the conduit opening is free of metal powder or any other impurities.
- If glue or bonding agent is applied, make sure that it does not adhere to the movable parts or enter the Switch, otherwise the Switch may not work correctly or cause contact failure. Some types of glue or bonding agent may generate a gas that may have a negative influence on the Switch. Pay the utmost attention when selecting the glue or locking agent.
- Some models allow changes in the head direction. When changing the head of such a model, make sure that the head is free of any foreign substance. Tighten each screw of the head to the rated torque.
- Be sure to take measures so that no foreign material, oil, or water will enter the Switch through the conduit opening. Be sure to attach a connector suitable for the cable thickness and tighten the connector securely to the rated torque.
- Do not impose shock or vibration on the Actuator while it is fully pressed. Otherwise, the Actuator will partially abrade and an actuation failure may result.

Precautions for Correct Use

Switch Operation

- The Switch in actual operation may cause accidents that cannot be foreseen from the design stage. Therefore, the Switch must be practically tested before actual use.
- When testing the Switch, be sure to apply the actual load conditions together with the actual operating environment.
- All the performance ratings in this catalog are provided under the following conditions unless otherwise specified.

Inductive load: A minimum power factor of 0.4 (AC) or a maximum time constant of 7 ms (DC)

Lamp load: An inrush current 10 times higher than the normal current

Motor load: An inrush current 6 times higher than the normal current

1. Ambient temperature: 5°C to 35°C
2. Ambient humidity: 40% to 70%.

Note: An inductive load causes a problem especially in DC circuitry. Therefore, it is essential to know the time constants (L/R) of the load.

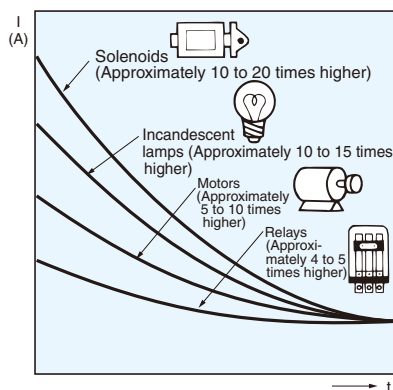

Mechanical Conditions for Switch Selection

- An Actuator suitable for the operating method must be selected. Ask your OMRON representative for details.
- Check the operating speed and switching frequency.
 1. If the operating speed is extremely low, switching of the movable contact will become unstable, thus resulting in incorrect contact or contact welding.
 2. If the operating speed is extremely high, the Switch may break due to shock. If the switching frequency is high, the switching of the contacts cannot keep up with the switching frequency. Make sure that the switching frequency is within the rated switching frequency.
- Do not impose excessive force on the Actuator, otherwise the Actuator may become damaged or not operate correctly.
- Make sure that the stroke is set within the suitable range specified for the model, or otherwise the Switch may break.

Electrical Characteristics for Switch Selection

Electrical Conditions

- The switching load capacity of the Switch greatly varies between AC and DC. Always be sure to apply the rated load. The control capacity will drastically drop if it is a DC load. This is because a DC load has no current zero-cross point, unlike an AC load. Therefore, if an arc is generated, it may continue comparatively for a long time. Furthermore, the current direction is always the same, which results in contact relocation, whereby the contacts easily stick to each other and do not separate when the surfaces of the contacts are uneven.

- If the load is inductive, counter-electromotive voltage will be generated. The higher the voltage is, the higher the generated energy will be, which will increase the abrasion of the contacts and contact relocation load conditions. Be sure to use the Switch within the rated conditions.
- If the load is a minute voltage or current load, use a Switch designed for minute loads. The reliability of silver-plated contacts, which are used by standard Switches, will be insufficient if the load is a minute voltage or current load.

Connections

- With a Za contact form, do not contact a single Switch to two power supplies that are different in polarity or type.

Power Connection Examples (Connection of Different Polarities)

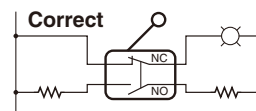
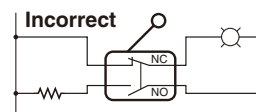

Connect the load to the same polarities.



Incorrect Power Connection Example

(Connection of Different Power Supplies)
There is a risk of AC and DC mixing.

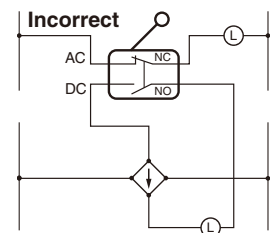

- Do not use a circuit that will short-circuit if a fault occurs, otherwise the charged part may melt and break off.

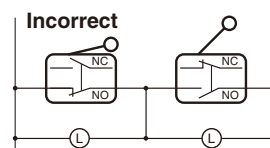

- Application of Switch to a Low-voltage, Low-current Electronic Circuit.
 1. If bouncing or chattering of the contacts results and causes problems, take the following countermeasures.
 - (a) Insert an integral circuit.
 - (b) Suppress the generation of pulses from the contact bouncing or chattering of the contacts so that it is less than the noise margin of the load.
 2. Conventional silver-plated contacts are not suitable for this application, in which particularly high reliability is required. Use gold-plated contacts, which are ideal for handling minute voltage or current loads.
 3. The contacts of the Switch used for an emergency stop must be normally closed with a positive opening mechanism.
- To protect the Switch from damage due to short-circuits, be sure to connect in series a quick-response fuse with a breaking current 1.5 to 2 times larger than the rated current to the Switch. When complying with EN certified ratings, use a 10-A IEC 60269-compliant gI or gG fuse.

Contact Protection Circuits

Using a contact protection circuit to increase the contact durability, prevent noise, and suppress the generation of carbide or nitric acid. Be sure to apply the contact protection circuit correctly, otherwise adverse results may occur. The following tables shows typical examples of contact protection circuits. If the Switch is used in an excessively humid location for

switching a load that easily generates arcs, such as an inductive load, the arcs may generate NO_x, which will change into HNO₃ when it reacts with moisture. Consequently, the internal metal parts may corrode and the Switch may fail. Be sure to select the best contact protection circuit from the following table.

Typical Examples of Contact Protection Circuits

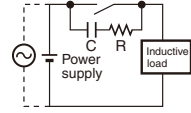
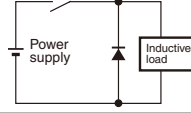
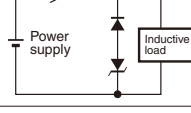
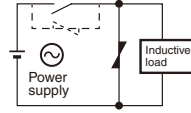
Circuit example	Applicable current		Features and remarks	Element selection
	AC	DC		
	*	Yes	* Load impedance must be much smaller than the CR circuit impedance when using the Switch for an AC voltage. The operating time of the contacts will be increased if the load is a Relay or solenoid. Connecting the CR circuit in parallel to the load is effective when the power supply voltage is 24 or 48 V and in parallel to the contacts when the power supply voltage is 100 to 200 V.	Use the following as guides for C and R values: C: 1 to 0.5 μF per 1 A of contact current (A) R: 0.5 to 1 Ω per 1 V of contact voltage (V) These values depend on various factors, including the load characteristics. Confirm optimum values experimentally. Capacitor C suppresses the discharge when the contacts are opened, while the resistor R limits the current applied when the contacts are closed the next time. Generally, use a capacitor with a low dielectric strength of 200 to 300 V. For applications in an AC circuit, use an AC capacitor (with no polarity).
	Yes	Yes		
	No	Yes	The energy stored in the coil reaches the coil as current via the diode connected in parallel, and is dissipated as Joule heat by the resistance of the inductive load. This type of circuit increases the release time more than the CR type.	Use a diode having a reverse breakdown voltage of more than 10 times the circuit voltage, and a forward current rating greater than the load current.
	No	Yes	This circuit effectively shortens the reset time in applications where the release time of a diode circuit is too slow.	Use a Zener diode with a low breakdown voltage.
	Yes	Yes	This circuit prevents a high voltage from being applied across the contacts by using the constant-voltage characteristic of a varistor. This circuit also somewhat increases the reset time. Connecting the varistor across the load is effective when the supply voltage is 24 to 48 V, and across the contacts when the supply voltage is 100 to 200 V.	---

Do not use the following types of contact protection circuit.

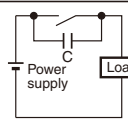
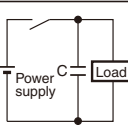
 <p>This circuit arrangement is very effective for diminishing arcing at the contacts when breaking the circuit. However, since electrical energy is stored in C (capacitor) when the contacts are open, the current from C flows into the contacts when they close. This may lead to contact welding.</p>	 <p>This circuit arrangement is very useful for diminishing arcing at the contacts when breaking the circuit. However, since the charging current to C flows into the contacts when they are closed, contact welding may occur.</p>
---	--

Although it is thought that switching a DC inductive load is more difficult than a resistive load, an appropriate contact protection circuit can achieve almost the same characteristics.

Using Switches for Microloads

Contact failure may occur if a Switch for a general load is used to switch a microload circuit. Use Switches in the ranges shown in the diagram right. However, even when using microload models within the operating range shown here, if inrush current occurs when the contact is opened or closed, it may increase contact wear and so decrease durability. Therefore, insert a contact protection circuit where necessary. The minimum applicable load is the N-level reference value. This value indicates the malfunction reference level for the reliability level of 60% (λ_{60}) (JIS C5003). The equation, $\lambda_{60} = 0.5 \times 10^{-6} / \text{operations}$ indicates that the estimated malfunction rate is less than 1/2,000,000 operations with a reliability level of 60%.

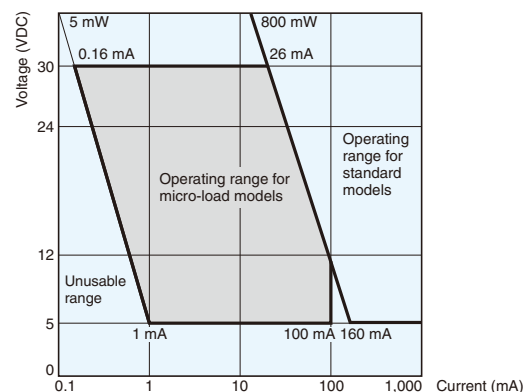

Operating Environment

- The Switches are designed for use indoors. Using a Switch outdoors may cause it to malfunction.
- Do not use the Switch submerged in oil or water, or in locations continuously subject to splashes of water. Doing so may result in oil or water entering the Switch interior.
- Confirm suitability (applicability) in advance before using the Switch where it would be subject to oil, water, chemicals, or detergents. Contact with any of these may result in contact failure, insulation failure, earth leakage faults, or burning.
- Do not use the Switch in the following locations:
 - Locations subject to corrosive gases
 - Locations subject to severe temperature changes
 - Locations subject to high humidity, resulting in condensation
 - Locations subject to severe vibration
 - Locations subject to cutting chips, dust, or dirt
 - Locations subject to high humidity or high temperature
- Use protective covers to protect Switches that are not specified as waterproof or airtight whenever they are used in locations subject to splattering or spraying oil or water, or to accumulation of dust or dirt.

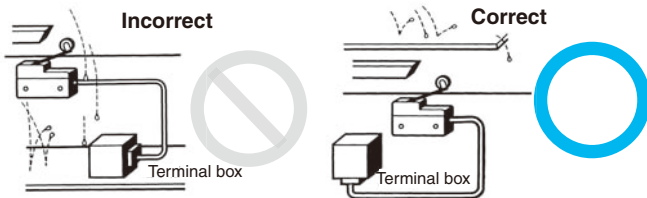

- Be sure to install the Switch so that the Switch is free from dust or metal powder. The Actuator and the Switch casing must be protected from the accumulation of dust or metal powder.

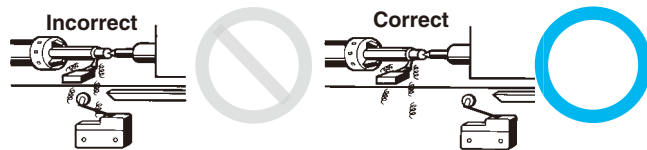

- Do not use the Switch in locations where the Switch is exposed to steam or hot water at a temperature greater than 60°C.
- Do not use the Switch under temperatures or other environmental conditions not within the specified ranges. The rated permissible ambient temperature range varies with the model. Refer to the *Specifications* in this catalog. If the Switch is exposed to radical temperature changes, the thermal shock may deform the Switch and the Switch may malfunction.

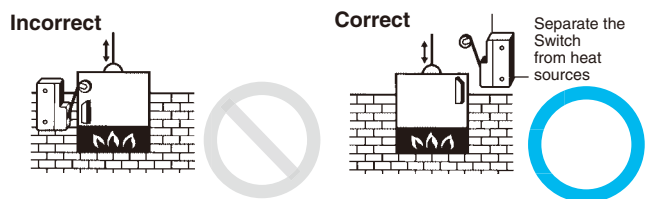

- Be sure to protect the Switch with a cover if the Switch is in a location where the Switch may be actuated by mistake or where the Switch is likely cause an accident.

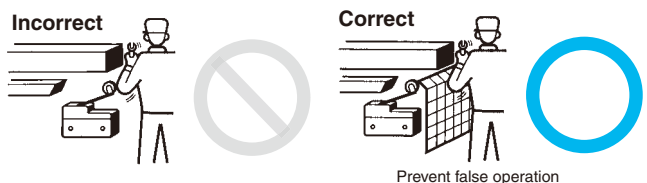

- Make sure to install the Switch in locations free of vibration or shock. If vibration or shock is continuously imposed on the Switch, contact failure, malfunction, or decrease in service life may be caused by abrasive powder generated from the internal parts. If excessive vibration or shock is imposed on the Switch, the contacts may malfunction or become damaged.
- Do not use the Switch with silver-plated contacts for long periods if the switching frequency of the Switch is comparatively low or the load is minute. Otherwise, sulfuric film will be generated on the contacts and contact failures may result. Use the Switch with gold-plated contacts or use a Switch designed for minute loads instead.
- Do not use the Switch in locations with corrosive gas, such as sulfuric gas (H₂S or SO₂), ammonium gas (NH₃), nitric gas (HNO₃), or chlorine gas (Cl₂), or high temperature and humidity. Otherwise, contact failure or corrosion damage may result.
- If the Switch is used in locations with silicone gas, arc energy may create silicon dioxide (SiO₂) on the contacts and a contact failure may result. If there is silicone oil, silicone sealant, or wire covered with silicone close to the Switch, attach a contact protection circuit to suppress the arcing of the Switch or eliminate the source of silicone gas generation.

Regular Inspection and Replacement

- If the Switch is normally closed with low switching frequency (e.g., once or less per day), a reset failure may result due to the deterioration of the parts of the Switch. Regularly inspect the Switch and make sure that the Switch is in good working order.
- In addition to the mechanical durability or electrical durability of the Switch described previously, the durability of the Switch may decrease due to the deterioration of each part, especially rubber, resin, and metal. Regularly inspect the Switch and replace any part that has deteriorated to prevent accidents from occurring.
- If the Switch is not turned ON and OFF for a long period of time, contact reliability may be reduced due to contact oxidation. Continuity failure may result in accidents (i.e., the switch may not turn ON due to increased contact resistance.)
- Be sure to mount the Switch securely in a clean location to ensure ease of inspection and replacement. The Switch with operation indicator is available, which is ideal if the location is dark or does not allow easy inspection or replacement.

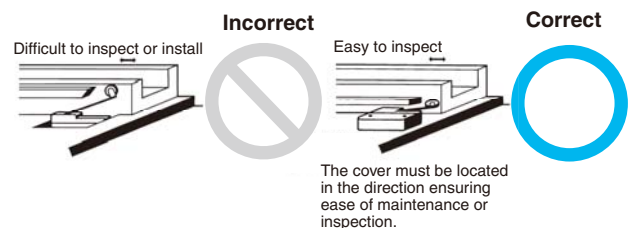

Storage of Switch

- When storing the Switch, make sure that the location is free of corrosive gas, such as H₂S, SO₂, NH₃, HNO₃, or Cl₂, or dust and does not have a high temperature or humidity.
- Be sure to inspect the Switch before use if it has been stored for three months or more.

Typical Problems, Probable Causes, and Remedies

	Problem	Probable cause	Remedy	
Mechanical failure	1. The Actuator does not operate. 2. The Actuator does not return. 3. The Actuator has been deformed. 4. The Actuator is worn. 5. The Actuator has been damaged.	The shape of the dog or cam is incorrect.	<ul style="list-style-type: none"> Change the design of the dog or cam and smooth the contacting surface of the cam. Scrutinize the suitability of the Actuator. (Make sure that the Actuator does not bounce.) 	
		The contacting surface of the dog or cam is rough.		
		The Actuator in use is not suitable.	<ul style="list-style-type: none"> Attach a decelerating device or change the mounting position of the Switch. 	
		The operating direction of the Actuator is not correct.		
		The operation speed is excessively high.	<ul style="list-style-type: none"> Change the stroke. 	
		Excessive stroke.		
		The rubber or grease hardened due to low temperature.	<ul style="list-style-type: none"> Use a cold-resistive Switch. 	
		The accumulation of sludge, dust, or cuttings.		
	There is a large deviation in operating position (with malfunctioning involved).	Dissolution, expansion, or swelling damage to the rubber parts of the driving mechanism.	<ul style="list-style-type: none"> Use a drip-proof model or one with high degree of protection. Use a protection cover and change the solvent and materials. 	
		Damage to and wear and tear of the internal movable spring.	<ul style="list-style-type: none"> Regularly inspect the Switch. Use a better quality Switch. Tighten the mounting screws securely. Use a mounting board. 	
Wear and tear of the internal mechanism.				
The loosening of the mounting screws causing the position to be unstable.				
The terminal part wobbles (The mold part has been deformed).	Overheating due to a long soldering time.	<ul style="list-style-type: none"> Solder the Switch quickly. Change the lead wire according to the carry current and ratings. 		
	The Switch has been connected to and pulled by thick lead wires with excessive force.			
	High temperature or thermal shock resulted.	<ul style="list-style-type: none"> Use a temperature-resistive Switch or change mounting positions. 		
Failures related to chemical or physical characteristics	Contact chattering.	Vibration or shock is beyond the rated value.	<ul style="list-style-type: none"> Attach an anti-vibration mechanism. Attach a rubber circuit to the solenoid. Increase the operating speed (with an accelerating mechanism). 	
		Shock has been generated from a device other than the Switch.		
		Too-slow operating speed.		
	Oil or water penetration.	The sealing part has not been tightened sufficiently.	<ul style="list-style-type: none"> Use a drip-proof or waterproof Switch. Use the correct connector and cable. 	
		The wrong connector has been selected and does not conform to the cable.		
		The wrong Switch has been selected.		
		The terminal part is not molded.		
	Deterioration of the rubber part.	The Switch has been burnt or carbonated due to the penetration of dust or oil.	<ul style="list-style-type: none"> Use an oil-resistant rubber or Teflon bellows. Use a weather-resistant rubber or protective cover. Use a Switch with a metal bellows protective cover. 	
		The expansion and dissolution of the rubber caused by solvent or lubricating oil.		
		Cracks due to direct sunlight or ozone.		
	Corrosion (rusting or cracks).	Damage to the rubber caused by scattered or heated cuttings.	<ul style="list-style-type: none"> Change the lubricating oil or change mounting positions. Use a crack-resistant material. 	
		The oxidation of metal parts resulted due to corrosive solvent or lubricating oil.		
		The Switch has been operated in a corrosive environment, near the sea, or on board a ship.		
		The electrical deterioration of metal parts of the Switch resulted due to the ionization of cooling water or lubricating oil.		
	Failures related to electric characteristics	No actuation. No current breakage. Contact welding.	The cracking of alloyed copper due to rapid changes in temperature.	<ul style="list-style-type: none"> Add an erasing circuit. Use a Switch with a special alloy contact or use a sealed Switch. Reduce the switching frequency or use a Switch with a large switching capacity. Change the circuit design. Use a protective box.
			Inductive interference in the DC circuit.	
Carbon generated on the surface of the contacts due to switching operations.				
A short-circuit or contact welding due to contact migration.				
Contact welding due to an incorrectly connected power source.				
Foreign materials or oil penetrated into the contact area.				

Other

- The standard material for the Switch seal is nitrile rubber (NBR), which has superior resistance to oil. Depending on the type of oil or chemicals in the application environment, however, NBR may deteriorate, e.g., swell or shrink. Confirm performance in advance.
- The correct Switch must be selected for the load to ensure contact reliability. Refer to *Precautions* for microloads in individual product information for details.
- Wire the leads as shown in the following diagram.

Correct Wiring

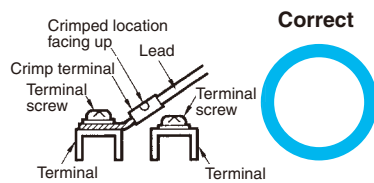

Incorrect Wiring

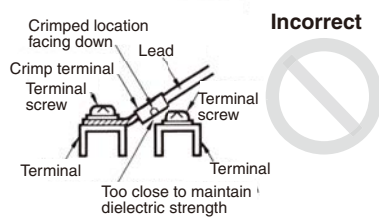



WARNING

This catalog is a guide to help customers select the proper safety products. Observe the following items when choosing products, select the right products for your devices or equipment, and develop a safety-related system to fully utilize product functions.

Setting Up a Risk Assessment System

The items listed in this catalog must be used properly in terms of product location as well as product performance and functionality. Part of the process of selecting and using these products should include the introduction and development of a risk assessment system early in the design development stage to help identify potential dangers in your equipment that will optimize safety product selection. A badly designed risk assessment system often results in poor choices when it comes to safety products.

- Related International Standards:
ISO 14121 Principles of Risk Assessment

Safety Policy

When developing a safety system for the devices and equipment that use safety products, make every effort to understand and conform to the entire series of international and industrial standards available, such as the examples given below.

- Related International Standards:
ISO 12100 Basic Concepts, General Principles for Design
IEC 61508 Functional Safety of Electrical/Electronic/Programmable Electronic Safety-related Systems

Role of Safety Products

Safety products have functions and mechanisms that ensure safety as defined by standards. These functions and mechanisms are designed to attain their full potential within safety-related systems. Make sure you fully understand all functions and mechanisms, and use that understanding to develop systems that will ensure optimal usage.

- Related International Standards:
ISO 14119 Interlocking Devices Associated with Guards-Principles for Design and Selection

Installing Safety Products

Make sure that properly educated and trained engineers are selected to develop your safety-related system and to install safety products in devices and equipment.

- Related International Standards:
ISO 12100 Basic Concepts, General Principles for Design
IEC 61508 Functional Safety of Electrical/Electronic/Programmable Electronic Safety-related Systems

Observing Laws and Regulations

Safety products should conform to pertinent laws, regulations, and standards, but make sure that they are used in accordance with the laws, regulations, and standards of the country where the devices and equipment incorporating these products are distributed.

- Related International Standards:
IEC 60204 Electrical Equipment of Machines

Observing Usage Precautions

Carefully read the specifications and precautions listed in this catalog for your product as well as all items in the Operating Manual packed with the product to learn usage procedures that will optimize your choice. Any deviation from precautions will lead to unexpected device or equipment failure not anticipated by safety-related systems or fire originating from equipment failure.

Transferring Devices and Equipment

When transferring devices and equipment, be sure to keep one copy of the Operating Manual and pack another copy with the device or equipment so the person receiving it will have no problem operating it.

- Related International Standards:
ISO 12100 Basic Concepts, General Principles for Design
IEC 61508 Functional Safety of Electrical/Electronic/Programmable Electronic Safety-related Systems

Read and Understand This Catalog

Please read and understand this catalog before purchasing the products. Please consult your OMRON representative if you have any questions or comments.

Warranty and Limitations of Liability

WARRANTY

OMRON's exclusive warranty is that the products are free from defects in materials and workmanship for a period of one year (or other period if specified) from date of sale by OMRON.

OMRON MAKES NO WARRANTY OR REPRESENTATION, EXPRESS OR IMPLIED, REGARDING NON-INFRINGEMENT, MERCHANTABILITY, OR FITNESS FOR PARTICULAR PURPOSE OF THE PRODUCTS. ANY BUYER OR USER ACKNOWLEDGES THAT THE BUYER OR USER ALONE HAS DETERMINED THAT THE PRODUCTS WILL SUITABLY MEET THE REQUIREMENTS OF THEIR INTENDED USE. OMRON DISCLAIMS ALL OTHER WARRANTIES, EXPRESS OR IMPLIED.

LIMITATIONS OF LIABILITY

OMRON SHALL NOT BE RESPONSIBLE FOR SPECIAL, INDIRECT, OR CONSEQUENTIAL DAMAGES, LOSS OF PROFITS, OR COMMERCIAL LOSS IN ANY WAY CONNECTED WITH THE PRODUCTS, WHETHER SUCH CLAIM IS BASED ON CONTRACT, WARRANTY, NEGLIGENCE, OR STRICT LIABILITY.

In no event shall responsibility of OMRON for any act exceed the individual price of the product on which liability is asserted.

IN NO EVENT SHALL OMRON BE RESPONSIBLE FOR WARRANTY, REPAIR, OR OTHER CLAIMS REGARDING THE PRODUCTS UNLESS OMRON'S ANALYSIS CONFIRMS THAT THE PRODUCTS WERE PROPERLY HANDLED, STORED, INSTALLED, AND MAINTAINED AND NOT SUBJECT TO CONTAMINATION, ABUSE, MISUSE, OR INAPPROPRIATE MODIFICATION OR REPAIR.

Application Considerations

SUITABILITY FOR USE

OMRON shall not be responsible for conformity with any standards, codes, or regulations that apply to the combination of products in the customer's application or use of the product.

At the customer's request, OMRON will provide applicable third party certification documents identifying ratings and limitations of use that apply to the products. This information by itself is not sufficient for a complete determination of the suitability of the products in combination with the end product, machine, system, or other application or use.

The following are some examples of applications for which particular attention must be given. This is not intended to be an exhaustive list of all possible uses of the products, nor is it intended to imply that the uses listed may be suitable for the products:

- Outdoor use, uses involving potential chemical contamination or electrical interference, or conditions or uses not described in this catalog.
- Nuclear energy control systems, combustion systems, railroad systems, aviation systems, medical equipment, amusement machines, vehicles, safety equipment, and installations subject to separate industry or government regulations.
- Systems, machines, and equipment that could present a risk to life or property.

Please know and observe all prohibitions of use applicable to the products.

NEVER USE THE PRODUCTS FOR AN APPLICATION INVOLVING SERIOUS RISK TO LIFE OR PROPERTY WITHOUT ENSURING THAT THE SYSTEM AS A WHOLE HAS BEEN DESIGNED TO ADDRESS THE RISKS, AND THAT THE OMRON PRODUCT IS PROPERLY RATED AND INSTALLED FOR THE INTENDED USE WITHIN THE OVERALL EQUIPMENT OR SYSTEM.

Disclaimers

CHANGE IN SPECIFICATIONS

Product specifications and accessories may be changed at any time based on improvements and other reasons.

It is our practice to change model numbers when published ratings or features are changed, or when significant construction changes are made. However, some specifications of the product may be changed without any notice. When in doubt, special model numbers may be assigned to fix or establish key specifications for your application on your request. Please consult with your OMRON representative at any time to confirm actual specifications of purchased product.

DIMENSIONS AND WEIGHTS

Dimensions and weights are nominal and are not to be used for manufacturing purposes, even when tolerances are shown.

ERRORS AND OMISSIONS

The information in this catalog has been carefully checked and is believed to be accurate; however, no responsibility is assumed for clerical, typographical, or proofreading errors, or omissions.

PERFORMANCE DATA

Performance data given in this catalog is provided as a guide for the user in determining suitability and does not constitute a warranty. It may represent the result of OMRON's test conditions, and the users must correlate it to actual application requirements. Actual performance is subject to the OMRON Warranty and Limitations of Liability.

PROGRAMMABLE PRODUCTS

OMRON shall not be responsible for the user's programming of a programmable product, or any consequence thereof.

COPYRIGHT AND COPY PERMISSION

This catalog shall not be copied for sales or promotions without permission.

This catalog is protected by copyright and is intended solely for use in conjunction with the product. Please notify us before copying or reproducing this catalog in any manner, for any other purpose. If copying or transmitting this catalog to another, please copy or transmit it in its entirety.