



INSTALLATION INSTRUCTIONS

Model AG65033/AG6503C3/AG65033L Type 1 or Type 2 Surge Protection Device

IMPORTANT SAFETY INSTRUCTIONS • SAVE THESE INSTRUCTIONS

! WARNING *Risk of Electric Shock*

- Thoroughly read instructions before installing unit.
- Installation and Service to be performed by a qualified licensed electrician.
- Intended for indoor or outdoor use.

- All wiring must comply with all state and local electrical codes including the National Electrical Code and/or Canadian Electrical Code.
- Suitable for use on a circuit capable of delivering not more than 50,000 rms symmetrical amperes.
- This unit contains no serviceable parts.
- This product does not protect against direct lightning strikes.

Type 1 installation:

A typical installation of a type 1 SPD will be connected between the secondary of the service transformer and the line side of the service panel. This installation is intended to be installed without overcurrent protection to the SPD.

Type 2 installation:

A typical installation of a type 2 SPD will be connected to the load side of the service panel and is intended to be installed with overcurrent protection to the SPD.

1. Determining location:
 - Ensure conductor lengths are as short and straight as possible for best performance. Do not coil excess wire. The SPD functions best if all bends in wires are rounded, ideally to a 4" radius. Hard 90 degree bend will reduce efficiency. Cut all leads to the correct length. Do not coil excess leads.
 - Install appropriate weatherproof fittings if the unit is to be mounted outside.
 - Bracket part number AG1BRKT is also available if needed.
2. Connect wires as shown within diagrams. If your application does not match one of the diagrams below consult your supplier.
3. Ensure all mounting and electrical connections are correct and securely fastened. Once energized the green indicator LED will be ON.

Maintenance:

- AC Voltage SPD:
 - Periodically check SPD to ensure green indicator LED is ON. If green LED is OFF protection has diminished and the SPD should be replaced immediately.

347/600 VAC WYE 3 PHASE

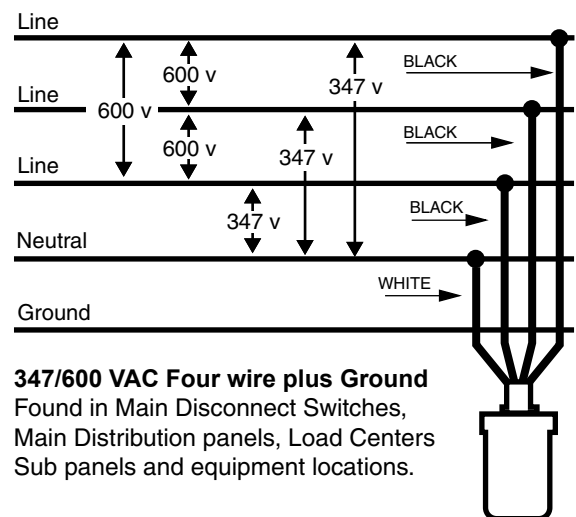
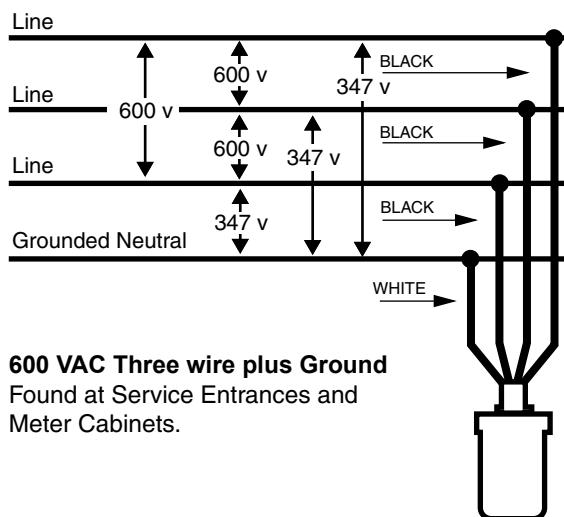

**ONE YEAR LIMITED PRODUCT WARRANTY
For
INTERMATIC SURGE PROTECTIVE DEVICES**

(1) What is Covered By This Limited Warranty

Replacement of Product

Intermatic Incorporated ("Intermatic") warrants to the original purchaser only, Intermatic AG Series Surge Protective Devices (each a "Product") shall be free from defects in material or workmanship for a period of one year (12 months) from date of purchase or 18 months from date of manufacture. If the purchaser discovers a defect in material or workmanship, the purchaser must promptly submit a warranty claim. Upon a determination by Intermatic that the Product is defective, Intermatic, at its sole option shall correct any defect in material or workmanship by replacing the Defective Product at Intermatic's expense. The foregoing remedy is the purchaser's exclusive remedy for a breach of warranty.

The product must be installed in the appropriate application in complete accordance with the installation instructions. All building wiring and other connections to the Product must conform to all applicable national, state, and local electrical codes; the Product must not be opened, modified, exposed to extreme heat or cold, submerged or subjected to abnormal use or service. All products must be used in accordance with the instructions provided with the Product and the purchaser shall be solely responsible for selecting a Product model with specifications appropriate for the equipment to be protected. Intermatic shall determine, in its sole discretion, whether any Product returned by a purchaser has been used in accordance with its instructions, is an appropriate model for the purchaser's use thereof, and whether the Product is defective.

(2) What is Not Covered By This Warranty

Intermatic does not warrant (a) defects in the Product or damage to any equipment caused by the failure to properly install the Product, (b) damage caused by use of the Product for purposes other than those for which it was designed, (c) damage caused by disaster such as fire, flood and wind, (d) damage caused by unauthorized attachments or modification of the Product, (e) damage to the Product occurring during the shipment, (f) electrical disturbances exceeding published product specifications, (g) damage to the Product caused by any other abuse or misuse by the purchaser, or (h) damage due to direct or vicinity lightning strikes. This warranty applies to residential and commercial applications. This device is not intended to provide protection during Utility voltage swells or loss of neutral conditions which are by definition not transient events and are not covered by this warranty.

(3) Disclaimer of Warranty

THE FOREGOING WARRANTIES ARE IN LIEU OF ALL OTHER EXPRESSED WARRANTIES. TO THE EXTENT ALLOWED BY LAW, ANY IMPLIED WARRANTIES OF MERCHANTABILITY OR FITNESS FOR A PARTICULAR PURPOSE ARE LIMITED IN DURATION OF THIS LIMITED WARRANTY.

(4) Limitation of Remedies

IN NO CASE SHALL INTERMATIC BE LIABLE FOR ANY SPECIAL, INCIDENTAL, OR CONSEQUENTIAL DAMAGES BASED UPON BREACH OF WARRANTY, BREACH OF CONTRACT, NEGLIGENCE, STRICT TORT, OR ANY OTHER LEGAL THEORY. SUCH EXCLUDED DAMAGES INCLUDE, BUT ARE NOT LIMITED TO, DAMAGE TO SOFTWARE, LOSS OF DATA, LOSS OF PROFITS, LOSS OF SAVINGS OR REVENUE, LOSS OF USE OF THE PRODUCT OR ANY ASSOCIATED EQUIPMENT, COST OF CAPITAL, COST OF ANY SUBSTITUTE EQUIPMENT, FACILITIES OR SERVICES, DOWNTIME, THE CLAIMS OF THIRD PARTIES INCLUDING CUSTOMERS, DAMAGE TO PROPERTY AND PERSONAL INJURY. SOME STATES DO NOT ALLOW LIMITS ON WARRANTIES OR ON REMEDIES FOR BREACH IN CERTAIN TRANSACTIONS, IN SUCH STATES, THE LIMITS IN THIS PARAGRAPH AND IN PARAGRAPH (3) MAY NOT APPLY.

(5) Time Limit for Bringing Suit

No action arising out of any claimed breach of warranty may be brought more than one year after the cause of action has occurred.

(6) No Other Warranties

Unless modified in writing signed by both parties, this agreement is understood to be the complete and exclusive agreement between the parties, superseding all prior agreements, oral or written, and all other communications between the parties relating to the subject matter of this agreement. No employee of Intermatic or any other party is authorized to make any warranty in addition to those made in this agreement. This warranty is made by: Intermatic Incorporated/After Sales Service, 7777 Winn Rd., Spring Grove, IL. 60081-9698/815-675-7000 <http://www.intermatic.com>

INTERMATIC INCORPORATED
SPRING GROVE, ILLINOIS 60081-9698
<http://www.intermatic.com>