

PowerXL DC1



PowerXL DG1



Enclosed 18-Pulse Drive



OEM Drives

2.1	PowerXL DC1 Series Drives	
	Product Description	V6-T2-2
2.2	PowerXL DA1 Series Drives	
	Product Description	V6-T2-11
2.3	M-Max Series Drives	
	Product Description	V6-T2-20

General Purpose Industrial Drives

2.4	PowerXL DG1 Series Drives	
	Product Description	V6-T2-30
2.5	SVX9000 Drives	
	Product Overview	V6-T2-45
	SVX9000 Drives	
	Product Description	V6-T2-48
	SVX9000 Enclosed Drives	
	Product Description	V6-T2-87
	SVX9000 VFD Pump Panels	
	Product Description	V6-T2-111

General Purpose HVAC Drives

2.6	H-Max Series Drives	
	Product Overview	V6-T2-131
	H-Max Drives	
	Product Description	V6-T2-132
	H-Max IntelliPass and IntelliDisconnect Drives	
	Product Description	V6-T2-141

Performance Drives

2.7	SPX9000 Drives	
	Product Description	V6-T2-158
2.8	Low Harmonic Drives	
	Enclosed Passive Filtered Drives	
	Product Description	V6-T2-200
	Enclosed 18-Pulse Drives	
	Product Description	V6-T2-233
2.9	LCX9000 Liquid Cooled Drives	
	Product Description	V6-T2-263
2.10	SPA9000/SPN9000/SPI9000 Common DC Bus Drives	
	Product Description	V6-T2-280



PowerXL DC1 Series Drives

2



Product Description

Eaton's PowerXL™ DC1 variable frequency drives are the next generation of drives specifically engineered for today's machinery applications.

The DC1 is compact with only 14 basic parameters, SmartWire-DT™ connectivity, and outstanding ease of mounting and installation. The DC1 is perfect for quick commissioning and is ideal for panel builders. This drive supports single-phase motor applications, and detachable terminal blocks make control wiring much easier.

Models rated at 480 volts, three-phase, 50/60 Hz are available in sizes ranging from 1 to 15 hp. Models rated at 240 volts, single- or three-phase, 50/60 Hz are available in sizes ranging from 0.5 to 7.5 hp. Models rated at 115 volts, single-phase, 50/60 Hz are available in the 0.5 to 3 hp size range.

Features

- Compact, space-saving design
- Rugged and reliable—175% for 2s, 50°C rated
- DIN rail and screw mountable (FS1 and FS2)
- Side-by-side installation
- Industry-leading efficiency delivers energy savings to the customer
- Optional integrated EMC filters make the unit suitable for commercial and industrial networks
- Brake chopper as standard in frames 2 and higher
- Temperature-controlled fan
- RS-485/Modbus® and CANopen™ as standard
- PI controller as standard
- SmartWire capability
- Removable I/O terminal blocks
- Contactor style power wiring
- Compatibility with single-phase motors

Standards and Certifications

Product

- Complies with EN61800-3 (2004)

EMC (At Default Settings)

- EMC Category C1, C2 and C3 at default settings (1m, 5m, 25m)

Safety ①

- 61800-5-1
- EN 60529
- CE
- UL
- cUL
- UkrSepro
- c-Tick
- RoHS compliant



Note

- ① See unit nameplate for more detailed approvals.

Contents

Description

	<i>Page</i>
PowerXL DC1 Series Drives	
Catalog Number Selection	V6-T2-3
Product Selection	V6-T2-4
Accessories	V6-T2-6
Technical Data and Specifications	V6-T2-7
Dimensions	V6-T2-9

Catalog Number Selection

DC1 Series Adjustable Frequency AC Drives

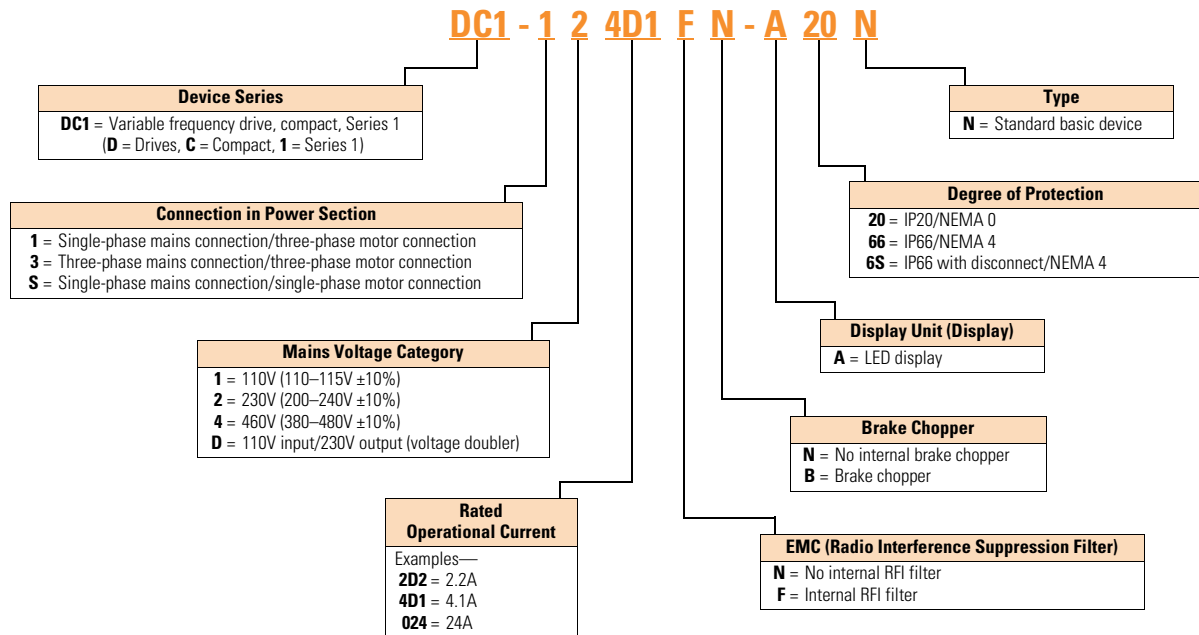

2.1

Adjustable Frequency Drives

PowerXL DC1 Series Drives

Product Selection

2

IP20

DC1 Series IP20 Enclosure Drives ^①



hp ^②	kW	Volts	100% Continuous Current In (A)	Frame Size ^③	Catalog Number
0.5	0.37	115V single-phase in/ 115V single-phase out	7	1	DC1-S17D0NN-A20N
0.75	0.55		10.5	2	DC1-S1011NB-A20N
0.5	0.37	200–240V single-phase in/ 200–240V single-phase out	4.3	1	DC1-S24D3NN-A20N ^④
1	0.75		7	1	DC1-S27D0NN-A20N ^④
1.5	1.1		10	2	DC1-S2011NB-A20N ^④
0.5	0.37	115V single-phase in/ 230V three-phase out	2.3	1	DC1-1D2D3NN-A20N ^④
1	0.75		4.3	1	DC1-1D4D3NN-A20N
1.5	1.1		5.8	2	DC1-1D5D8NB-A20N
0.5	0.37	200–240V single-phase in/ 230V three-phase out	2.3	1	DC1-122D3NN-A20N ^④
1	0.75		4.3	1	DC1-124D3NN-A20N ^④
2	1.5		7	1	DC1-127D0NN-A20N ^④
2	1.5		7	2	DC1-127D0NB-A20N ^④
3	2.2		10.5	2	DC1-12011NB-A20N ^④
5	4		15	3	DC1-12015NB-A20N
0.5	0.37	200–240V three-phase in/ 230V three-phase out	2.3	1	DC1-322D3NN-A20N
1	0.75		4.3	1	DC1-324D3NN-A20N
2	1.5		7	1	DC1-327D0NN-A20N
2	1.5		7	2	DC1-327D0NB-A20N ^④
3	2.2		10.5	2	DC1-32011NB-A20N ^④
5	4		18	3	DC1-32018NB-A20N ^④
1	0.75	380–480V three-phase in/ 460V three-phase out	2.2	1	DC1-342D2NN-A20N ^④
2	1.5		4.1	1	DC1-344D1NN-A20N ^④
2	1.5		4.1	2	DC1-344D1NB-A20N ^④
3	2.2		5.8	2	DC1-345D8NB-A20N ^④
5	4		9.5	2	DC1-349D5NB-A20N ^④
7.5	5.5		14	3	DC1-34014NB-A20N ^④
10	7.5		18	3	DC1-34018NB-A20N ^④
15	11		24	3	DC1-34024NB-A20N ^④

Notes

- ① These are constant torque/high overload rated drives.
- ② For all applications, select the unit such that the motor current is less than or equal to the rated continuous output current.
- ③ Brake chopper circuit available as standard in frames 2 and 3.
- ④ RFI version available. Substitute with DC1-*****F*-**** for this option.

IP66

DC1 Series IP66 Enclosure Drives ^①

hp ^②	kW	Volts	100% Continuous Current In (A)	Frame Size ^③	Catalog Number
0.5	0.37	115V single-phase in/ 115V single-phase out	7	1	DC1-S17D0NN-A6SN ^④
0.75	0.55		10.5	2	DC1-S1011NB-A6SN ^④
0.5	0.37	200–240V single-phase in/ 200–240V single-phase out	4.3	1	DC1-S24D3NN-A6SN ^{④⑤}
1	0.75		7	1	DC1-S27D0NN-A6SN ^{④⑤}
1.5	1.1		10	2	DC1-S2011NB-A6SN ^{④⑤}
0.5	0.37	115V single-phase in/ 230V three-phase out	2.3	1	DC1-1D2D3NN-A6SN ^④
1	0.75		4.3	1	DC1-1D4D3NN-A6SN ^④
1.5	1.1		5.8	2	DC1-1D5D8NB-A6SN ^④
0.5	0.37	200–240V single-phase in/ 230V three-phase out	2.3	1	DC1-122D3NN-A6SN ^{④⑤}
1	0.75		4.3	1	DC1-124D3NN-A6SN ^{④⑤}
2	1.5		7	1	DC1-127D0NN-A6SN ^{④⑤}
2	1.5		7	2	DC1-127D0NB-A6SN ^{④⑤}
3	2.2		10.5	2	DC1-12011NB-A6SN ^{④⑤}
5	4		15	3	DC1-12015NB-A6SN ^④
0.5	0.37	200–240V three-phase in/ 230V three-phase out	2.3	1	DC1-322D3NN-A6SN ^④
1	0.75		4.3	1	DC1-324D3NN-A6SN ^④
2	1.5		7	1	DC1-327D0NN-A6SN ^④
2	1.5		7	2	DC1-327D0NB-A6SN ^{④⑤}
3	2.2		10.5	2	DC1-32011NB-A6SN ^{④⑤}
5	4		18	3	DC1-32018NB-A6SN ^{④⑤}
1	0.75	380–480V three-phase in/ 460V three-phase out	2.2	1	DC1-342D2NN-A6SN ^{④⑤}
2	1.5		4.1	1	DC1-344D1NN-A6SN ^{④⑤}
2	1.5		4.1	2	DC1-344D1NB-A6SN ^{④⑤}
3	2.2		5.8	2	DC1-345D8NB-A6SN ^{④⑤}
5	4		9.5	2	DC1-349D5NB-A6SN ^{④⑤}
7.5	5.5		14	3	DC1-34014NB-A6SN ^{④⑤}
10	7.5		18	3	DC1-34018NB-A6SN ^{④⑤}

Notes

- ① These are constant torque/high overload rated drives.
 ② For all applications, select the unit such that the motor current is less than or equal to the rated continuous output current.
 ③ Brake chopper circuit available as standard in frames 2 and 3.
 ④ Non-disconnect version available. Substitute with **-A66N**.
 ⑤ RFI version available. Substitute with DC1-*******F***.***** for this option.

Accessories

DC1 Series

2

PC Communication Kit and Copy/Paste Module

Description	Catalog Number
Bluetooth copy/paste communication stick	DX-COM-STICK
USB PC connection kit	DX-COM-PCKIT

Encoder Feedback Plug-In Option Module and Miscellaneous Cards

Description	Catalog Number
Local control/test option card	DXC-EXT-LOCSIM
HVACO drive running and tripped relay output card	DXC-EXT-2R01A0
Dual relay output card	DXC-EXT-2R0
110V logic input card	DXC-EXT-IO110
230V logic input card	DXC-EXT-IO230

Remote Keypad

Description	Catalog Number
LED remote keypad—7-segment display, IP54 rated	DX-KEY-LED ^①
OLED remote keypad—full text display, multi-line text, multi-language, IP54	DX-KEY-OLED ^①

Extension Cables and Data Cable Splitter

Description	Catalog Number
RJ45 communication cable w/terminating resistor	DX-CBL-TERM
RS-485 data cable, RJ45, 0.5m	DX-CBL-RJ45-0M5
RS-485 data cable, RJ45, 1.0m	DX-CBL-RJ45-1M0
RS-485 data cable, RJ45, 3.0m	DX-CBL-RJ45-3M0
RS-485 three-way data cable splitter, RJ45	DX-SPL-RJ45-3SL
RS-485 data cable splitter, RJ45, (1 connector to 2 socket)	DX-SPL-RJ45-2SL1PL

SmartWire Modules

Description	Catalog Number
SmartWire-DT interface for DC1 IP20	DX-NET-SWD3

Note

^① Includes 1m RS-485 data cable.

Technical Data and Specifications

DC1 Series

Ratings

PowerXL DC1 Basic Controller IP20 Standard Ratings

Description	Specification
Protections	
Overload protection	150% for 60s for every 600 seconds
Overvoltage protection	Yes
Undervoltage protection	Yes
Ground fault protection	Yes
Overtemperature protection	Yes
Motor overload protection	Yes
Motor stall protection	Yes

Programmable Parameters

Description
Built-in Help card
14 Standard operation parameters
Reference scaling
Programmable start and stop functions
DC-brake at start and stop
Programmable V/Hz curve
Adjustable switching frequency
Autorestart function after fault
Protections and supervisions
Power section fault indication
External fault
Fieldbus communication
Second deceleration time
Analog input range selection, signal scaling and filtering
PI controller
Skip frequencies

Specifications

PowerXL DC1 Series Drives

Description	Specification
Input Ratings	
Input voltage (V_{in})	$\pm 10\%$
Input frequency (f_{in})	50/60 Hz (variation up to 48–62 Hz)
Connection to power	Maximum of one time every 30 seconds
Output Ratings	
Output voltage	0 to V_{in} ①
Continuous output current	Continuous rated current I_N at ambient temperature max. 122°F (50°C), 150% for 60 seconds, 175% for 2 seconds
Output frequency	0 to 500 Hz
Frequency resolution	0.1 Hz
Initial output current (I_{H})	175% for 2s for every 20 seconds Torque depends on motor
Control Characteristics	
Operation mode	U/f control, slip compensation
Switching frequency	4 to 32 kHz
Voltage reference	10 Vdc (max. 10 mA)
Field weakening point	0 to 500 Hz
Acceleration time	0.1 to 600 seconds
Deceleration time	0.1 to 600 seconds
Brake Resistor (Minimum Values) ②	
230V Series	FS2 and FS3 47 ohms
400V Series	FS2 100 ohms, FS3 47 ohms
Ambient Conditions	
Ambient operating temperature	+14°F (–10°C), no frost to +122°F (+50°C): Rated loadability I_N IP20—NEMA 0
Storage temperature	–40°F (–40°C) to +140°F (+60°C)
Relative humidity	0 to 95% RH, noncondensing, non-corrosive, no dripping water
Enclosure class	IP20 (FS1–FS3)

Notes

① Exception: 115V single-phase in, 230V three-phase out.

② Only FS2 and FS3 drives are equipped with brake chopper circuit.

2.1

Adjustable Frequency Drives

PowerXL DC1 Series Drives

Standards—DC1 Series

2

I/O Specifications

- Digital inputs DI1–DI4 are programmable
- Digital, relay and analog outputs are programmable

Includes:

- Four inputs (two digital and two digital/analog)
- Analog inputs
 - 4–20 mA
 - 0–10V
- One output (analog or digital)
- One relay output
- RS-485 interface

Reliability

- Pretested components
- Computerized testing
- Final test with full load
- Conformal-coated boards
- Eaton's Electrical Services & Systems: national network of AF drive specialists

DC1 Series I/O Interface

Terminal	Signal	Factory Preset	Description
1	+24 Vdc	Control voltage for DI1–DI4	— Maximum load 100 mA Reference potential V
2	DI1	Digital Input 1	Start Enable FWD
3	DI2	Digital Input 2	Start Enable REV
4	DI3	Digital Input 3	Fixed frequency FF1
	AI2	Analog Input 2	Fixed frequency FF1
			Digital: 8–30V (high) Analog: 0 to +10V ($R_i > 72 \text{ k}\Omega$) 0/4–20 mA ($R_B = 500 \Omega$) Can be switched with parameter P16
5	+10 Vdc	Reference voltage, Output (+10V)	— Maximum load 10 mA Reference potential 0V
6	AI1	Analog Input 1	Frequency reference value ^① (fixed frequency)
	DI4	Digital Input 5	Frequency reference value ^① (fixed frequency)
			Analog: 0 to +10V ($R_i > 72 \text{ k}\Omega$) 0/4–20 mA ($R_B = 500 \Omega$) Can be switched with parameter P16 Digital: 8–30V (high)
7	0V	Reference potential	— 0V = connection terminal 9
8	AO1	Analog Output 1	Output frequency
	DO1	Digital Output 1	Output frequency
			Analog: 0 to +10V, maximum 4–20 mA Can be switched with parameter P-25 Digital: 8 to +24V
9	0V	Reference potential	— 0V connection terminal 7
10	K13	Relay 1, normally open contact	Active = RUN
11	K14	Relay 1, normally open contact	Active = RUN
			Maximum switching load: 250 Vac/6A or 30 Vdc/5A

Note

^① Programmable function.

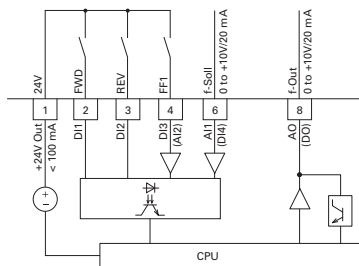

Dimensions

Approximate Dimensions in Inches (mm)

DC1, Sizes FS1–FS3, Degree of Protection IP20/NEMA 0

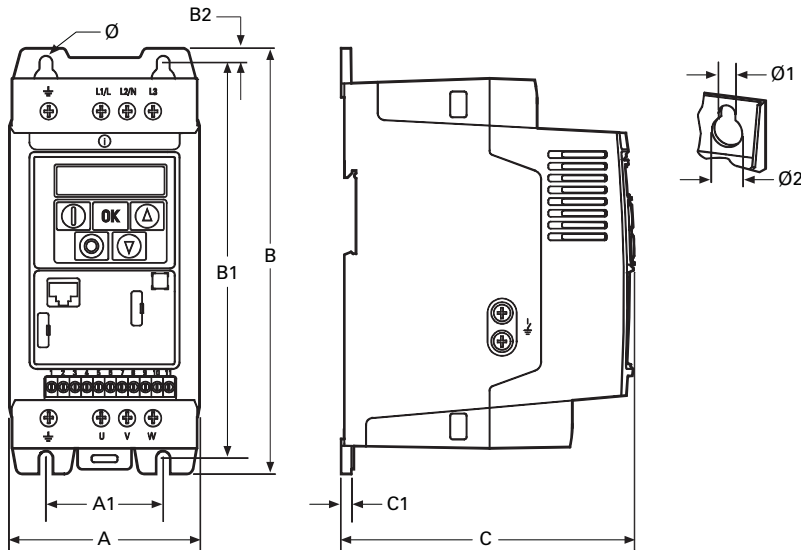

Frame Size	A	A1	B	B1	B2	C	C1	Ø1	Ø2	Weight lbs (kg)
FS1	3.19 (81.0)	1.97 (50.0)	7.24 (184.0)	6.69 (170.0)	0.28 (7.0)	4.88 (124.0)	0.16 (4.0)	0.24 (6.0)	0.47 (12.0)	2.43 (1.1)
FS2	4.21 (107.0)	2.95 (75.0)	9.09 (231.0)	8.46 (215.0)	0.31 (8.0)	5.98 (152.0)	0.20 (5.0)	0.24 (6.0)	0.47 (12.0)	5.73 (2.6)
FS3	5.16 (131.0)	3.94 (100.0)	10.75 (273.0)	10.04 (255.0)	0.33 (8.5)	6.89 (175.0)	0.20 (5.0)	0.24 (6.0)	0.47 (12.0)	8.82 (4.0)

DC1, Sizes FS1–FS3, Degree of Protection IP66/NEMA 4

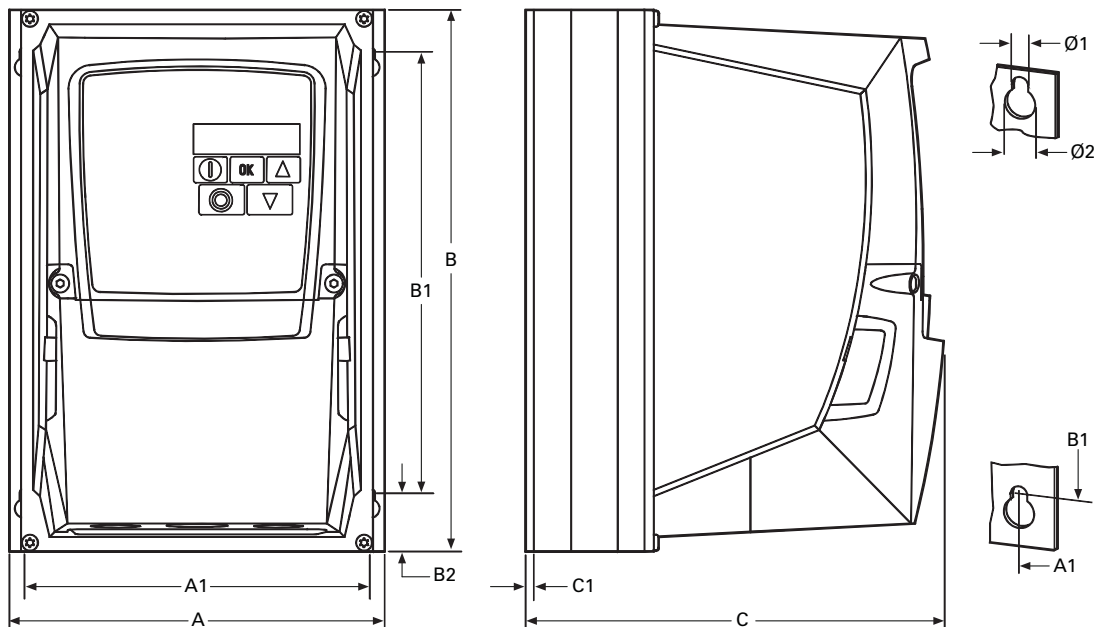

Frame Size	A	A1	B	B1	B2	C	C1	Ø1	Ø2	Weight lbs (kg)
FS1	6.34 (161.0)	5.85 (148.5)	9.13 (232.0)	7.44 (189.0)	0.98 (25.0)	7.24 (184.0)	0.14 (3.5)	0.15 (4.0)	0.31 (8.0)	5.51 (2.5)
FS2	7.40 (188.0)	6.93 (176.0)	10.12 (257.0)	7.87 (200.0)	1.12 (28.5)	7.58 (192.0)	0.14 (3.5)	0.16 (4.2)	0.33 (8.5)	10.36 (4.7)
FS3	8.29 (210.5)	7.78 (197.5)	12.20 (310.0)	9.90 (251.5)	1.31 (33.4)	9.21 (234.0)	0.14 (3.5)	0.16 (4.2)	0.33 (8.5)	17.42 (7.9)

2.1

Adjustable Frequency Drives

PowerXL DC1 Series Drives

Approximate Dimensions in Inches (mm)

2

DC1, Sizes FS1–FS3, Degree of Protection IP66/NEMA 4, with Local Controls

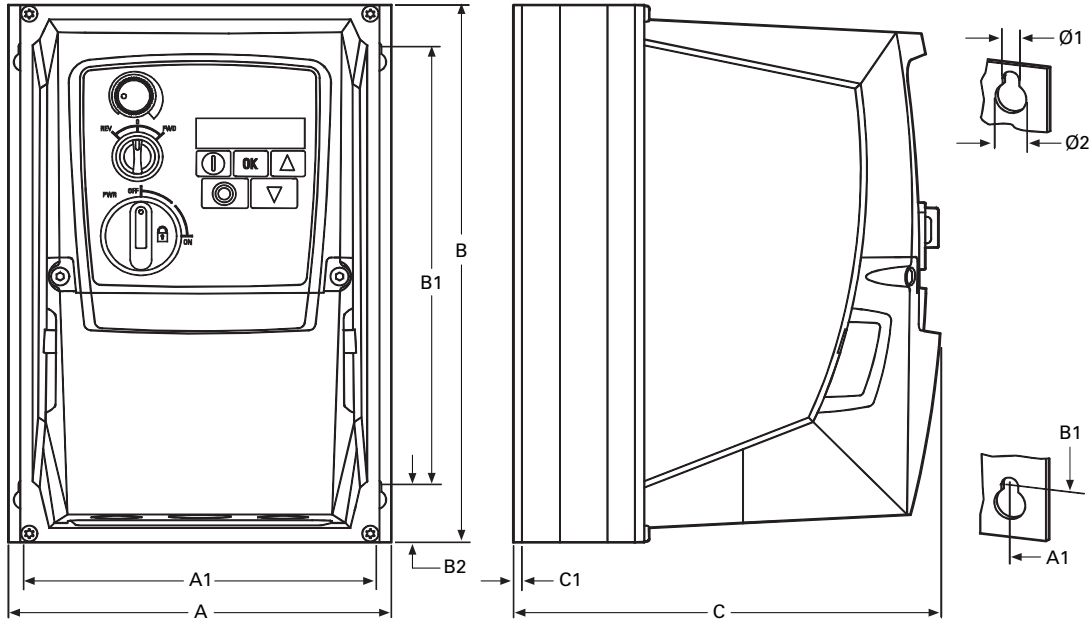

Frame Size	A	A1	B	B1	B2	C	C1	Ø1	Ø2	Weight lbs (kg)
FS1	6.34 (161.0)	5.85 (148.5)	9.13 (232.0)	7.44 (189.0)	0.98 (25.0)	7.24 (184.0)	0.14 (3.5)	0.15 (4.0)	0.31 (8.0)	6.17 (2.8)
FS2	7.40 (188.0)	6.93 (176.0)	10.12 (257.0)	7.87 (200.0)	1.12 (28.5)	7.58 (192.0)	0.14 (3.5)	0.16 (4.2)	0.33 (8.5)	11.02 (5.0)
FS3	8.29 (210.5)	7.78 (197.5)	12.20 (310.0)	9.90 (251.5)	1.31 (33.4)	9.21 (234.0)	0.14 (3.5)	0.16 (4.2)	0.33 (8.5)	18.08 (8.2)

PowerXL DA1 Series Drives



Product Description

Eaton's PowerXL™ DA1 variable frequency drives are the next generation of drives specifically engineered for today's machinery applications.

DA1 is the perfect match for demanding OEM applications. High-performance processor, safe torque off, multiple fieldbus protocols including SmartWire-DT, sensorless vector control and the possibility to operate permanent magnet motors are sure to leave a lasting impression.

Models rated at 480 volts, three-phase, 50/60 Hz are available in sizes ranging from 1 to 15 hp. Models rated at 240 volts, single- or three-phase, 50/60 Hz are available in sizes ranging from 0.5 to 7.5 hp. Models rated at 575 volts, three-phase, 50/60 Hz are available in sizes ranging from 1 to 20 hp.

Features

- Compact, space-saving design
- Rugged and reliable—200% for 4s 50°C rated
- DIN rail and screw mountable (FS1 and FS2)
- Side-by-side installation
- Industry-leading efficiency delivers energy savings to the customer
- Integrated EMC filters make the unit suitable for commercial and industrial networks
- Communication cards that integrate into the drive—
 - EtherNet/IP
 - DeviceNet
 - PROFIBUS-DP
 - EtherCAT
 - PROFINET
 - Modbus TCP
 - BACnet
- Brake chopper as standard in frames 2 and higher
- Temperature-controlled fan
- RS-485/Modbus® and CANopen™ as standard
- PID controller as standard
- Several fieldbus options
- SmartWire capability
- Removable I/O terminal blocks
- Contactor style power wiring
- 200% torque at zero speed
- Ability to run permanent magnet motors
- PLC programming
- Closed loop
- Conformal coated boards

Standards and Certifications

Product

- Complies with EN61800-3 (2004)

EMC (At Default Settings)

- EMC Category C1, C2 and C3 at default settings (1m, 5m, 25m)

Safety^①

- 61800-5-1
- EN 60529
- CE
- UL
- cUL
- UkrSepro
- c-Tick
- RoHS compliant



Note

- ① See unit nameplate for more detailed approvals.

Contents

Description

	<i>Page</i>
PowerXL DA1 Series Drives	
Catalog Number Selection	V6-T2-12
Product Selection	V6-T2-13
Accessories	V6-T2-15
Technical Data and Specifications	V6-T2-16
Dimensions	V6-T2-18

2.2

Adjustable Frequency Drives

PowerXL DA1 Series Drives

Catalog Number Selection

2

DA1 Series Adjustable Frequency AC Drives

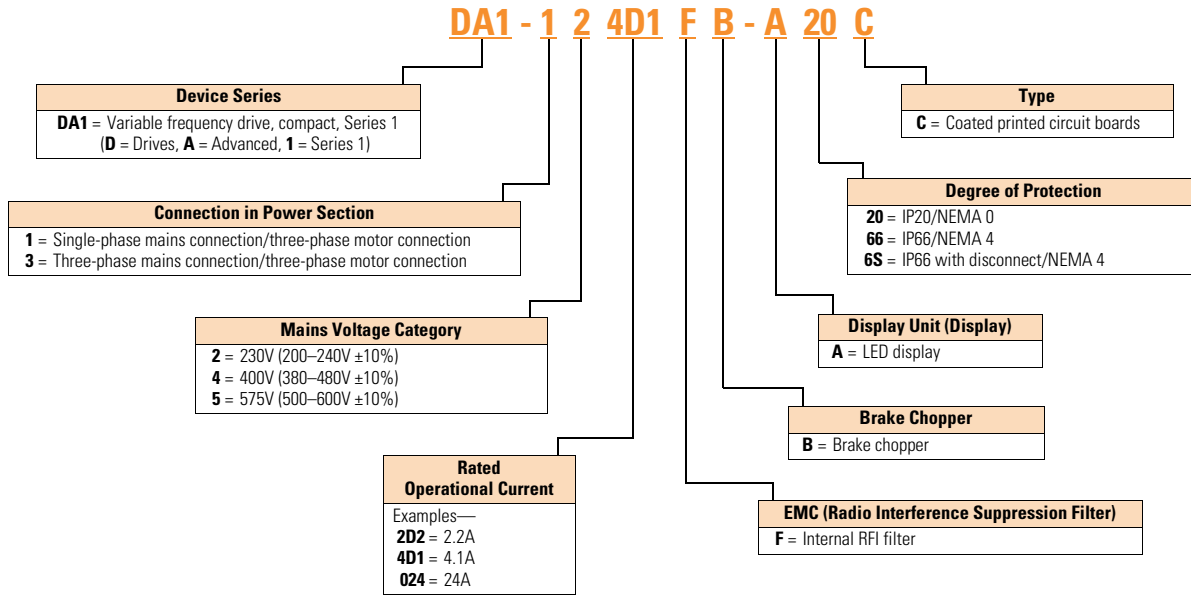

Product Selection

IP20

DA1 Series IP20 Enclosure Drives ^①

hp ^②	kW	Volts	100% Continuous Current In (A)	Frame Size ^③	Catalog Number
1	0.75	200–240V single-phase in/ 230V three-phase out	4.3	2	DA1-124D3FB-A20C
2	1.5		7	2	DA1-127D0FB-A20C
3	2.2		10.5	2	DA1-12011FB-A20C
1	0.75	200–240V three-phase in/ 230V three-phase out	4.3	2	DA1-324D3FB-A20C
2	1.5		7	2	DA1-327D0FB-A20C
3	2.2		10.5	2	DA1-32011FB-A20C
5	4		18	3	DA1-32018FB-A20C
7.5	5.5		24	3	DA1-32024FB-A20C
1	0.75	380–480V three-phase in/ 460V three-phase out	2.2	2	DA1-342D2FB-A20C
2	1.5		4.1	2	DA1-344D1FB-A20C
3	2.2		5.8	2	DA1-345D8FB-A20C
5	4		9.5	2	DA1-349D5FB-A20C
7.5	5.5		14	3	DA1-34014FB-A20C
10	7.5		18	3	DA1-34018FB-A20C
15	11		24	3	DA1-34024FB-A20C
1	0.75	500–600V three-phase in/ 575V three-phase out	2.1	2	DA1-352D1NB-A20C
2	4.5		3.1	2	DA1-353D1NB-A20C
3	2.2		4.1	2	DA1-354D1NB-A20C
5	4		6.5	2	DA1-356D5NB-A20C
7.5	5.5		9	2	DA1-359D0NB-A20C
10	7.5		12	3	DA1-35012NB-A20C
15	11		17	3	DA1-35017NB-A20C
20	15		22	3	DA1-35022NB-A20C

Notes

- ① These are constant torque/high overload rated drives.
- ② For all applications, select the unit such that the motor current is less than or equal to the rated continuous output current.
- ③ Brake chopper circuit available as standard in frames 2 and 3.

2.2

Adjustable Frequency Drives

PowerXL DA1 Series Drives

2

IP66



IP66S



DA1 Series IP66 Enclosure Drives ^①

hp ^②	kW	Volts	100% Continuous Current In (A)	Frame Size ^③	Catalog Number
1	0.75	200–240V single-phase in/ 230V three-phase out	4.3	2	DA1-124D3FB-A6SC ^④
2	1.5		7	2	DA1-127D0FB-A6SC ^④
3	2.2		10.5	2	DA1-12011FB-A6SC ^④
1	0.75	200–240V three-phase in/ 230V three-phase out	4.3	2	DA1-324D3FB-A6SC ^④
2	1.5		7	2	DA1-327D0FB-A6SC ^④
3	2.2		10.5	2	DA1-32011FB-A6SC ^④
5	4		18	3	DA1-32018FB-A6SC ^④
1	0.75	380–480V three-phase in/ 460V three-phase out	2.2	2	DA1-342D2FB-A6SC ^④
2	1.5		4.1	2	DA1-344D1FB-A6SC ^④
3	2.2		5.8	2	DA1-345D8FB-A6SC ^④
5	4		9.5	2	DA1-349D5FB-A6SC ^④
7.5	5.5		14	3	DA1-34014FB-A6SC ^④
10	7.5		18	3	DA1-34018FB-A6SC ^④
1	0.75	500–600V three-phase in/ 575V three-phase out	2.1	2	DA1-352D1NB-A6SC
2	4.5		3.1	2	DA1-353D1NB-A6SC
3	2.2		4.1	2	DA1-354D1NB-A6SC
5	4		6.5	2	DA1-356D5NB-A6SC
7.5	5.5		9	2	DA1-359D0NB-A6SC
10	7.5		12	3	DA1-35012NB-A6SC
15	11		17	3	DA1-35017NB-A6SC

Notes

- ① These are constant torque/high overload rated drives.
- ② For all applications, select the unit such that the motor current is less than or equal to the rated continuous output current.
- ③ Brake chopper circuit available as standard in frames 2 and 3.
- ④ Non-disconnect version available. Substitute with **-A66C**.

Accessories

DA1 Series

PC Communication Kit and Copy/Paste Module

Description	Catalog Number
Bluetooth copy/paste communication stick	DX-COM-STICK
USB PC connection kit	DX-COM-PCKIT

Optional Communication Modules

Description	Catalog Number
DeviceNet plug-in interface module	DX-NET-DEVICENET
PROFIBUS-DP plug-in interface module	DX-NET-PROFIBUS
EtherNet/IP plug-in interface module	DX-NET-ETHERNET-2
EtherCAT plug-in interface module	DX-NET-ETHERCAT-2
PROFINET plug-in interface module	DX-NET-PROFINET-2
Modbus TCP plug-in interface module	DX-NET-MOVBUSTCP-2
BACnet plug-in interface module	DX-NET-BACNETIP-2

Encoder Feedback Plug-In Option Module and Miscellaneous Cards

Description	Catalog Number
Relay output option module	DXA-EXT-3RO
Encoder feedback plug-in option module	DXA-EXT-ENCOD

Remote Keypad

Description	Catalog Number
LED remote keypad—7-segment display, IP54 rated	DX-KEY-LED ^①
OLED remote keypad—full text display, multi-line text, multi-language, IP54	DX-KEY-OLED ^①

Extension Cables and Data Cable Splitter

Description	Catalog Number
RJ45 communication cable w/terminating resistor	DX-CBL-TERM
RS-485 data cable, RJ45, 0.5m	DX-CBL-RJ45-0M5
RS-485 data cable, RJ45, 1.0m	DX-CBL-RJ45-1M0
RS-485 data cable, RJ45, 3.0m	DX-CBL-RJ45-3M0
RS-485 three-way data cable splitter, RJ45	DX-SPL-RJ45-3SL
RS-485 data cable splitter, RJ45, (1 connector to 2 socket)	DX-SPL-RJ45-2SL1PL

SmartWire Modules

Description	Catalog Number
SmartWire-DT interface for DA1 IP20	DX-NET-SWD1

Note

^① Includes 1m RS-485 data cable.

Technical Data and Specifications

DA1 Series

Ratings

PowerXL DA1 Basic Controller IP20 Standard Ratings

Description	Specification
Protections	
Overload protection	150% for 60s for every 600 seconds
Overvoltage protection	Yes
Undervoltage protection	Yes
Ground fault protection	Yes
Overtemperature protection	Yes
Motor overload protection	Yes
Motor stall protection	Yes

Programmable Parameters

Description
Built-in Help card
14 Standard operation parameters
Reference scaling
Programmable start and stop functions
DC-brake at start and stop
Programmable V/Hz curve
Adjustable switching frequency
Autorestart function after fault
Protections and supervisions
Power section fault indication
External fault
Fieldbus communication
Safe torque off (STO) function
Analog input range selection, signal scaling and filtering
PI controller
Skip frequencies

Specifications

PowerXL DA1 Series Drives

Description	Specification
Input Ratings	
Input voltage (V_{in})	$\pm 10\%$
Input frequency (f_{in})	50/60 Hz (variation up to 48–62 Hz)
Connection to power	Maximum of one time every 30 seconds
Output Ratings	
Output voltage	0 to V_{in} ①
Continuous output current	Continuous rated current I_N at ambient temperature max. 122°F (50°C), 150% for 60 seconds, 200% for 4 seconds
Output frequency	0 to 500 Hz
Frequency resolution	0.1 Hz
Initial output current (I_{H})	200% for 4s for every 40 seconds Torque depends on motor
Control Characteristics	
Operation mode	U/f control, slip compensation, sensorless vector control (SLV), vector control with feedback (CLV)
Switching frequency	4 to 32 kHz
Voltage reference	10 Vdc (max. 10 mA)
Field weakening point	0 to 500 Hz
Acceleration time	0.1 to 600 seconds
Deceleration time	0.1 to 600 seconds
Brake Resistor (Minimum Values) ②	
230V Series	FS2 and FS3 15 ohms
400V Series	FS2 33 ohms, FS3 22 ohms
Ambient Conditions	
Ambient operating temperature	+14°F (–10°C), no frost to +122°F (+50°C): Rated loadability I_N IP20—NEMA 0
Storage temperature	–40°F (–40°C) to +140°F (+60°C)
Relative humidity	0 to 95% RH, noncondensing, non-corrosive, no dripping water
Enclosure class	IP20 (FS1–FS3)

Notes

- ① Exception: 115V single-phase in, 230V three-phase out.
 ② Only FS2 and FS3 drives are equipped with brake chopper circuit.

Standards—DA1 Series

I/O Specifications

- Digital inputs D11–D15 are programmable
- Digital, relay and analog outputs are programmable

Includes:

- Five inputs (three digital and two digital/analog)
- Analog inputs
 - 4–20 mA
 - 0–10V
- Two outputs (analog or digital)
- Two relay outputs
- RS-485 interface

Reliability

- Pretested components
- Computerized testing
- Final test with full load
- Conformal-coated boards
- Eaton's Electrical Services & Systems: national network of AF drive specialists

DA1 Series I/O Interface

Terminal	Signal	Factory Preset	Description
1	+24 Vdc	Control voltage for D11–D15	Maximum load 100 mA Reference potential V
2	D11	Digital Input 1	Start Enable FWD ①
3	D12	Digital Input 2	Start Enable REV ①
4	D13	Digital Input 3	Fixed frequency FF1/FF2 ①
5	+10 Vdc	Reference voltage, Output (+10V)	Maximum load 10 mA Reference potential 0V
6	A11	Analog Input 1	Frequency reference value ①
	D14	Digital Input 5	Frequency reference value ①
7	0V	Reference potential	0V = connection terminal 9
8	A01	Analog Output 1	Output frequency
	D01	Digital Output 1	Output frequency
9	0V	Reference potential	0V connection terminal 7
10	D14	Digital Input 4	Fixed frequency FF2 ①
	A12	Analog Input 2	Fixed frequency FF2 ①
11	A02	Analog output 2	Output current ①
	D02	Digital output 2	Output current ①
12	STO+	Safe Torque Off +	Enable = +24V
13	STO-	Safe Torque Off -	Enable = 0V
14	K11	Relay 1, changeover contact	Active = FAULT ①
15	K14	Relay 1, changeover contact (N/O)	Active = FAULT ①
16	K12	Relay 1, changeover contact (N/C)	Active = FAULT ①
17	K23	Relay 2, N/O contact	Active = FAULT ①
18	K24	Relay 2, N/C contact	Active = FAULT ①

Note

① Programmable function.

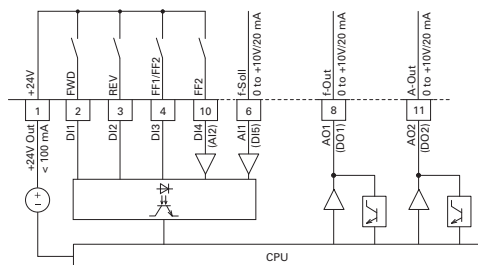

2.2

Adjustable Frequency Drives

PowerXL DA1 Series Drives

Dimensions

Approximate Dimensions in Inches (mm)

2 DA1, Sizes FS2 and FS3, Degree of Protection IP20/NEMA 0

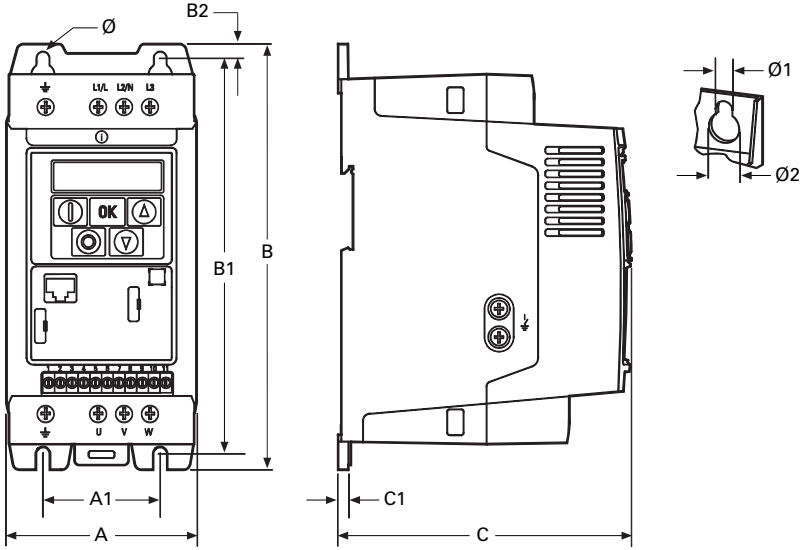

Frame Size	A	A1	B	B1	B2	C	C1	Ø1	Ø2	Weight lbs (kg)
FS2	4.21 (107.0)	2.95 (75.0)	9.09 (231.0)	8.46 (215.0)	0.31 (8.0)	7.32 (186.0)	0.20 (5.0)	0.24 (6.0)	0.47 (12.0)	3.97 (1.8)
FS3	5.16 (131.0)	3.94 (100.0)	10.75 (273.0)	10.04 (255.0)	0.33 (8.5)	8.03 (204.0)	0.20 (5.0)	0.24 (6.0)	0.47 (12.0)	7.72 (3.5)

DA1, Sizes FS2 and FS3, Degree of Protection IP66/NEMA 4

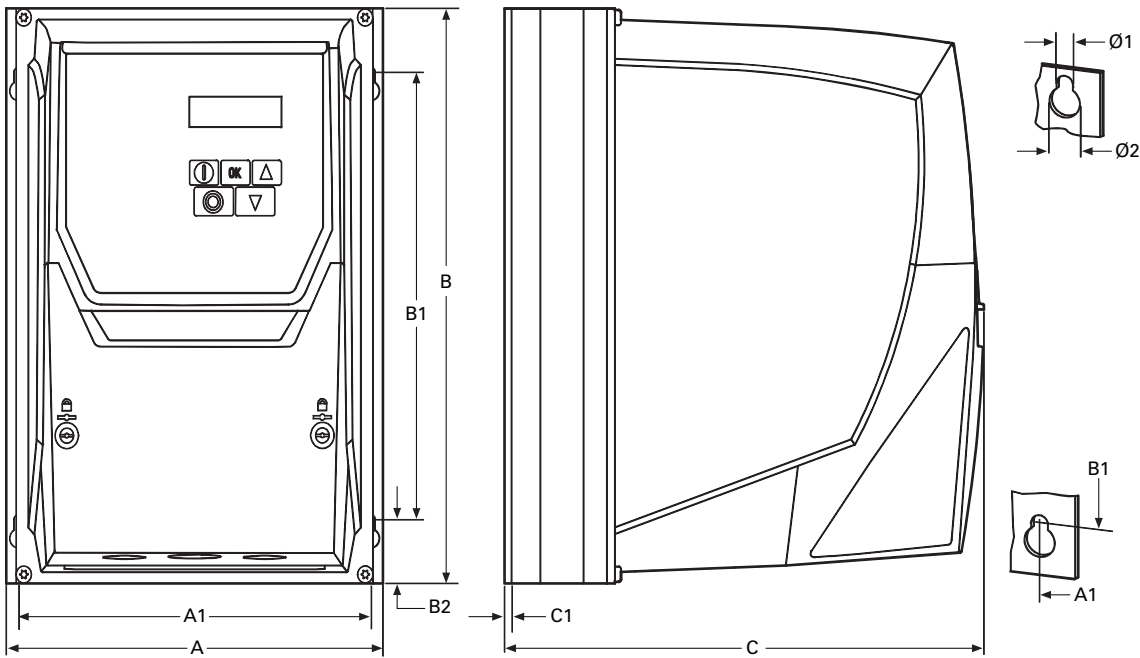

Frame Size	A	A1	B	B1	B2	C	C1	Ø1	Ø2	Weight lbs (kg)
FS2	7.40 (188.0)	6.93 (176.0)	10.12 (257.0)	7.87 (200.0)	0.79 (20.0)	9.42 (239.3)	0.14 (3.5)	0.16 (4.2)	0.33 (8.5)	10.4 (4.5)
FS3	8.29 (211.0)	7.78 (198.0)	12.20 (310.0)	9.90 (252.0)	0.98 (25.0)	10.48 (266.3)	0.14 (3.5)	0.16 (4.2)	0.33 (8.5)	15.9 (7.0)

Approximate Dimensions in Inches (mm)

DA1, Sizes FS2 and FS3, Degree of Protection IP66/NEMA 4, with Local Controls

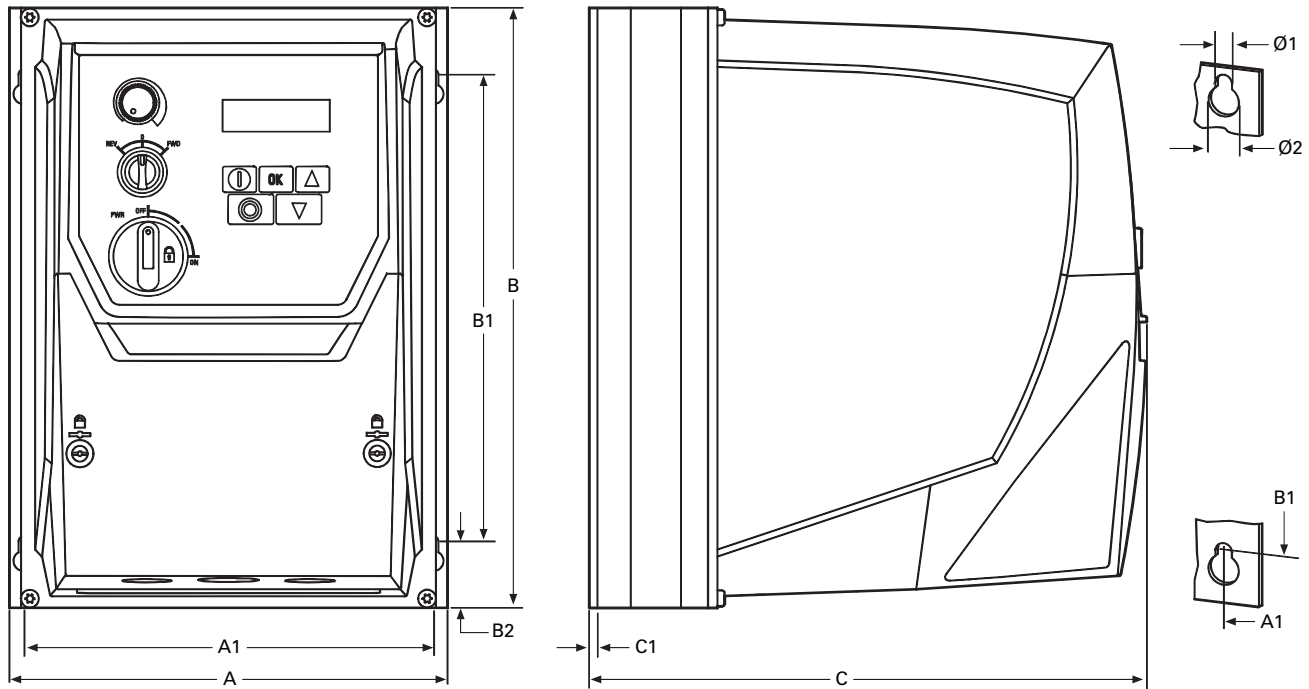

Frame Size	A	A1	B	B1	B2	C	C1	Ø1	Ø2	Weight lbs (kg)
FS2	7.40 (188.0)	6.93 (176.0)	10.12 (257.0)	7.87 (200.0)	0.79 (20.0)	9.42 (239.3)	0.14 (3.5)	0.16 (4.2)	0.33 (8.5)	10.6 (4.8)
FS3	8.29 (211.0)	7.78 (198.0)	12.20 (310.0)	9.90 (252.0)	0.98 (25.0)	10.48 (266.3)	0.14 (3.5)	0.16 (4.2)	0.33 (8.5)	16.1 (7.3)

M-Max Series Drives for Machinery Applications

2



Product Description

Eaton's M-Max™ Series Sensorless Vector Adjustable Frequency AC Drives are the next generation of drives specifically engineered for today's machinery applications. These micro-processor-based drives have standard features that can be programmed to tailor the drive's performance to suit a wide variety of application requirements. The M-Max product line uses a 32-bit microprocessor and insulated gate bipolar transistors (IGBTs) that provide quiet motor operation, high motor efficiency, and smooth low-speed performance. The size and simplicity of the M-Max make it ideal for hassle-free installation. Models rated at 575 volts, three-phase, 50/60 Hz are available in sizes ranging from 1 to 7-1/2 hp. Models rated at 480 volts, three-phase, 50/60 Hz are available in sizes ranging from 1/2 to 25 hp. Models rated at 240 volts, single- or three-phase, 50/60 Hz are available in sizes ranging from 1/4 to 15 hp. Models rated at 115 volts, single-phase, 50/60 Hz are available in the 1/4 to 1-1/2 hp size range.

The standard drive includes a digital display, and operating and programming keys on a visually appealing, efficient application programming interface. The display provides drive monitoring, as well as adjustment and diagnostic information. The keys are used for digital adjustment and programming of the drive, as well as for operator control. Separate terminal blocks for control and power wiring are provided for customer connections.

Contents

Description

	<i>Page</i>
M-Max Series Drives	
Catalog Number Selection	V6-T2-21
Product Selection	V6-T2-22
Accessories	V6-T2-23
Technical Data and Specifications	V6-T2-24
Dimensions	V6-T2-26

Features

- Ease of use—preset application macros, startup wizard, diagnostic capabilities
- Compact, space-saving design
- Rugged and reliable—150% torque for one minute, 50C rated, conformal coated boards
- DIN rail and screw mountable
- Side-by-side installation
- Industry leading efficiency delivers energy savings to the customer
- Integrated 5% DC choke (FS4 and FS5)
- Integrated EMC filters make the unit suitable for commercial and industrial networks
- IP21 as standard, option for NEMA® 1 (FS4 and FS5)
- IP20 as standard, option for IP21 and NEMA 1 (FS1–FS3)
- Brake chopper as standard in three-phase, applications of frames 2 (FS2) and larger
- Temperature-controlled fan
- RS-485/Modbus® as standard
- PID controller as standard
- Several fieldbus options

Standards and Certifications

Product

- Complies with EN61800-3 (2004)

Safety^①

- 61800-5-1
- EN60204-1
- CE
- UL
- cUL
- IEC
- RoHS compliant

EMC (At Default Settings)

- EMC Category C2, C3, and C4 (Level H): With an internal RFI filter option



Note

^① See unit nameplate for more detailed approvals.

Catalog Number Selection

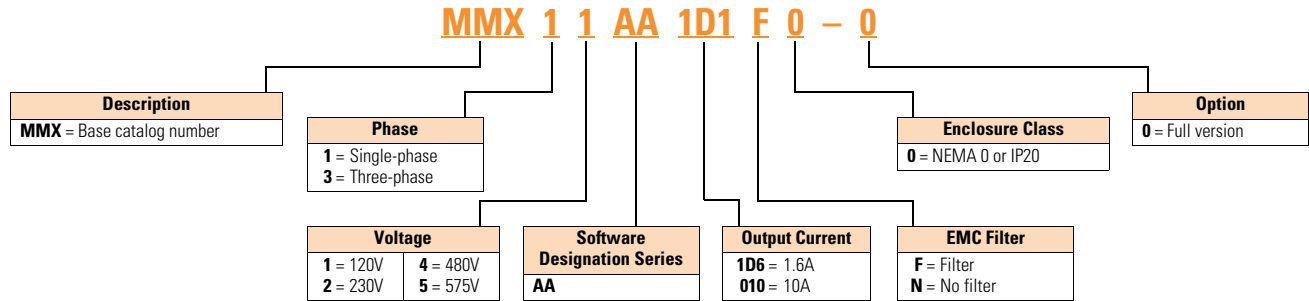

Product Selection

2

M-Max

M-Max Basic Controller



hp ^①	Volts ^②	100% Continuous Current I _n (A)	Nominal Input Current (A)	Frame Size	Catalog Number	
1/4	100–120V single-phase in 230V three-phase out	1.7	9.2	FS2	MMX11AA1D7N0-0	
1/2		2.4	11.6		MMX11AA2D4N0-0	
3/4		2.8	12.4		MMX11AA2D8N0-0	
1		3.7	15		MMX11AA3D7N0-0	
1-1/2		4.8	16.5		FS3	MMX11AA4D8N0-0
1/4	200–240V single-phase in 230V three-phase out	1.7	4.2	FS1	MMX12AA1D7F0-0 ^③	
1/2		2.4	5.7		MMX12AA2D4F0-0 ^③	
3/4		2.8	6.6		MMX12AA2D8F0-0 ^③	
1		3.7	8.3		FS2	MMX12AA3D7F0-0 ^③
1-1/2		4.8	11.2		MMX12AA4D8F0-0 ^③	
2		7	14.1		MMX12AA7D0F0-0 ^③	
3		9.6	15.8	FS3	MMX12AA9D6F0-0 ^③	
1/4	200–240V three-phase in 230V three-phase out	1.7	2.7	FS1	MMX32AA1D7N0-0	
1/2		2.4	3.5		MMX32AA2D4N0-0	
3/4		2.8	3.8		MMX32AA2D8N0-0	
1		3.7	4.3		FS2	MMX32AA3D7N0-0
1-1/2		4.8	6.8		MMX32AA4D8N0-0	
2		7	8.4		MMX32AA7D0N0-0	
3		11	13.4	FS3	MMX32AA011N0-0	
5		17	17	FS4	MMX32AA017F0-0 ^④	
7-1/2		25	25		MMX32AA025F0-0 ^④	
10		31	31	FS5	MMX32AA031F0-0 ^④	
15		38	38		MMX32AA038F0-0 ^④	
1/2	380–480V three-phase in 460V three-phase out	1.3	2.2	FS1	MMX34AA1D3F0-0 ^③	
3/4		1.9	2.8		MMX34AA1D9F0-0 ^③	
1		2.4	3.2		MMX34AA2D4F0-0 ^③	
1-1/2		3.3	4		FS2	MMX34AA3D3F0-0 ^③
2		4.3	5.6		MMX34AA4D3F0-0 ^③	
3		5.6	7.3		MMX34AA5D6F0-0 ^③	
4		7.6	9.6	FS3	MMX34AA7D6F0-0 ^③	
5		9	11.5		MMX34AA9D0F0-0 ^③	
7-1/2		12	14.9		MMX34AA012F0-0 ^③	
10		14	18.7		MMX34AA014F0-0 ^③	
10		16	16	FS4	MMX34AA016F0-0 ^④	
15		23	23		MMX34AA023F0-0 ^④	
20		31	31	FS5	MMX34AA031F0-0 ^④	
25		38	38		MMX34AA038F0-0 ^④	
1	575V three-phase in 575V three-phase out	1.7	2.0	FS3	MMX35AA1D7N0-0	
2		2.7	3.6		MMX35AA2D7N0-0	
3		3.9	5.0		MMX35AA3D9N0-0	
5		6.1	7.6		MMX35AA6D1N0-0	
7-1/2		9.0	10.4		MMX35AA9D0N0-0	

Notes

- ① Horsepower ratings are based on the use of a 240V, 460V, and 575V NEMA B, four- or six-pole squirrel cage induction motor and are for reference only. Units are to be selected such that the motor current is less than or equal to the MMX rated continuous output current.
- ② For 208V, 380V, or 415V applications, select the unit such that the motor current is less than or equal to the MMX rated continuous output current.
- ③ Units are also available without EMC filters. Substitute -N0-0 for this option.
- ④ Units are also available without EMC filters and 5% DC choke. Substitute -N0-0 for this option.

Accessories

M-Max Copy/Paste Module

Description	Catalog Number
Module is plugged onto the front of the drive to provide: upload/download of all parameters, direct link to a PC via USB interface for parameter assignment via MaxConnect software, and copying of parameters for a series of devices or when exchanging devices. No PC required	MMX-COM-PC

PC Cable

Description	Catalog Number
Remote download USB to RJ-45 cable with software driver disk	REM-USB-DOWN

NEMA Type 1 Kits ^①

Description	Catalog Number
NEMA Type 1 and IP21 kit for frame 1	MMX-IP21-FS1
NEMA Type 1 and IP21 kit for frame 2	MMX-IP21-FS2
NEMA Type 1 and IP21 kit for frame 3	MMX-IP21-FS3
NEMA Type 1 for frame 4	MMX-CKIT-FS4
NEMA Type 1 for frame 5	MMX-CKIT-FS5

Optional Communication Modules ^②

Description	Catalog Number
Communication adapter kit (FS1–FS3)	MMX-NET-XA
Communication adapter kit (FS4 and FS5)	MMX-NET-XA-45
PROFIBUS DP network card with serial connection	XMN-NET-PS-A
PROFIBUS DP network card with Sub-D connection	XMN-NET-PD-A
DeviceNet network card	XMN-NET-DN-A

Remote Keypad ^③

Description	Catalog Number
Keypad, bezel and cable	OPTRMT-BP-HMAX
Remote copy/paste keypad	MMX-REMKEY-TEXT
VFD adapter	MMX-ADAPTER-RJ45

Notes

- ① NEMA Type 1 kit provides conduit entry plate.
- ② Additional input and output reactors are available. Consult Eaton representative for a complete listing.
- ③ All three components are required for remote keypad operation.

Technical Data and Specifications

Ratings

M-Max Basic Controller IP20 Standard Ratings

Description	Specification
Protections	
Overcurrent protection	Trip limit $4.0 \times I_{fl}$ instantaneously
Overvoltage protection	115/230V series: 437 Vdc; 400V series: 874 Vdc; 575V series: 1048 Vdc trip level
Undervoltage protection	115/230V series: 183 Vdc; 400V series: 333 Vdc; 575V series: 460 Vdc trip level
Ground fault protection	Ground fault is tested before every start. In case of ground fault in motor or motor cable, only the frequency converter is protected
Overtemperature protection	Yes
Motor overload protection	Yes
Motor stall protection	Yes
Motor underload protection	Yes

Programmable Parameters

Description
Application macros: basic, pump, fan and high load (hoist)
Programmable start/stop and reverse signal logic (sinking or sourcing)
Reference scaling
Programmable start and stop functions
DC-brake at start and stop
Programmable V/Hz curve
Adjustable switching frequency
Autorestart function after fault
Protections and supervisions (all fully programmable; off, warning, fault)
Current signal input fault
External fault
Fieldbus communication
Eight preset speeds
Analog input range selection, signal scaling and filtering
PID controller
Skip frequencies

Specifications

M-Max Series Drives

Description	Specification
Input Ratings	
Input voltage (V_{in})	+10%/–15%
Input frequency (f_{in})	50/60 Hz (variation up to 45–66 Hz)
Connection to power	Once per minute or less (typical operation)
Output Ratings	
Output voltage	0 to V_{in} ①
Continuous output current	Continuous rated current I_N at ambient temperature max. 122°F (50°C), overload $1.5 \times I_N$ max. 1 min/10 min
Output frequency	0 to 320 Hz
Frequency resolution	0.01 Hz
Initial output current (I_{fl})	Current $2 \times I_N$ for 2 seconds in every 20-second period Torque depends on motor

Control Characteristics

Control method	Frequency control (V/Hz) open loop or sensorless vector control
Switching frequency	1.5 to 16 kHz; default 4 kHz
Frequency reference	Analog input: resolution 0.1% (10-bit), accuracy $\pm 1\%$ V/Hz Panel reference: resolution 0.01 Hz
Field weakening point	30 to 320 Hz
Acceleration time	0 to 3000 sec
Deceleration time	0 to 3000 sec
Braking torque	DC brake: $30\% \times T_n$ (without brake option)

Brake Resistor (Minimum Values) ②

230V Series	FS2 35 ohms and FS3 26 ohms, FS4 14 ohms, FS5 9 ohms
400V Series	FS2 75 ohms and FS3 54 ohms, FS4 28 ohms, FS5 17 ohms
575V Series	FS3 103 ohms

Ambient Conditions

Ambient operating temperature	14°F (–10°C), no frost to 122°F (+50°C): Rated loadability I_N
Storage temperature	–40°F (–40°C) to 158°F (70°C)
Relative humidity	0 to 95% RH, noncondensing, non-corrosive, no dripping water
Air quality	Chemical vapors: IEC 721-3-3, unit in operation, Class 3C2; Mechanical particles: IEC 721-3-3, unit in operation, Class 3S2
Altitude	100% load capacity (no derating) up to 3280 ft (1000m); 1% derating for each 328 ft (100m) above 3280 ft (1000m); max. 6560 ft (2000m)
Vibration	EN 60068-2-6; 3 to 150 Hz, displacement amplitude 1 mm (peak) at 3 to 15.8 Hz, max. acceleration amplitude 1G at 15.8 to 150 Hz
Shock	EN 50178, IEC 68-2-27 UPS Drop test (for applicable UPS weights); storage and shipping: max. 15G, 11 ms (in package)
Enclosure class	IP20 (FS1–FS3) IP21 (FS4 and FS5)

Notes

- ① Exception: 115V single-phase in, 230V three-phase out.
- ② Only three-phase FS2 and FS3 drives are equipped with brake chopper circuit.

Standards

I/O Specifications

- Digital inputs DI1–DI6 are freely programmable. The user can assign multiple functions to a single input
- Digital, relay, and analog outputs are freely programmable

Includes:

- Six digital inputs
- Two analog inputs
 - 4–20 mA
 - 0–10V
- One analog output
- One digital output
- Two relay outputs
- RS-485 interface

Reliability

- Pretested components
- Computerized testing
- Final test with full load
- Conformal-coated boards
- Eaton's Electrical Services & Systems: national network of AF drive specialists

M-Max I/O Interface

Terminal	Signal	Factory Preset	Description
1	+10V	—	Ref. output voltage
2	AI1	Freq. reference ^{P1}	Analog signal in 1
3	GND	—	I/O signal ground
6	24V	—	24V output for DI's
7	GND	—	I/O signal ground
8	DI1	Start forward ^{P1}	Digital input 1
9	DI2	Start reverse ^{P1}	Digital input 2
10	DI3	Preset speed ^{P1}	Digital input 3
A	A	FB communication	RS-485 signal A
B	B	FB communication	RS-485 signal B
4	AI2	PI actual value ^{P1}	Analog signal in 2
5	GND	—	I/O signal ground
13	GND	—	I/O signal ground
14	DI4	Preset speed B1 ^{P1}	Digital input 4
15	DI5	Fault reset ^{P1}	Digital input 5
16	DI6	Disable PI contr. ^{P1}	Digital input 6
18	A0	Output frequency ^{P1}	Analog output
20	DO	Active = READY ^{P1}	Digital signal out
22	R011	Relay out 1	Active = RUN ^{P1}
23	R012		
24	R021	Relay out 2	Active = FAULT ^{P1}
25	R022		
26	R023		

Note

^{P1} Parameter-selectable function.

2.3

Adjustable Frequency Drives

M-Max Series Drives

Dimensions

Approximate Dimensions in Inches (mm)

2 Dimensions and Frame Sizes, FS1–FS3 (FS = Frame Size)

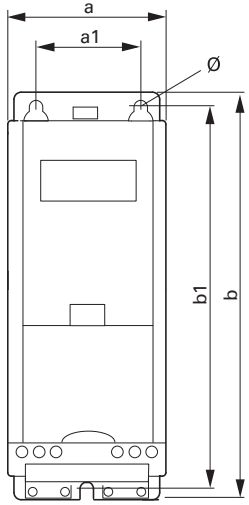

FS1

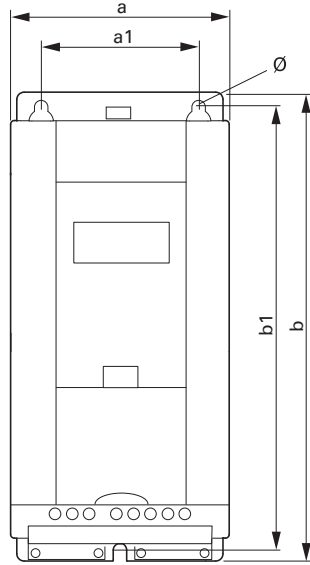

FS2

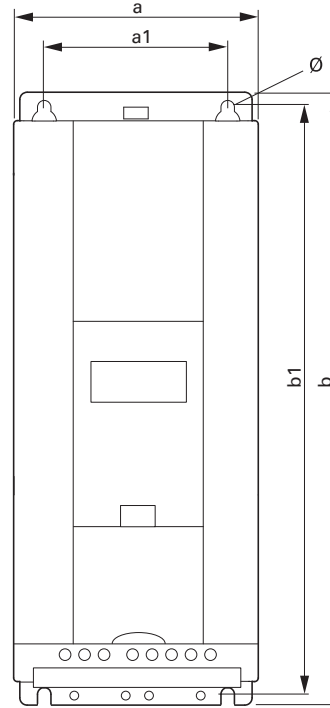

FS3

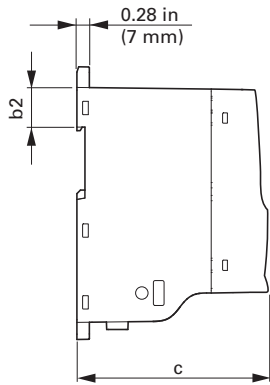

Approximate Dimensions in Inches (mm)

Dimensions and Frame Sizes, FS4 and FS5 (FS = Frame Size)

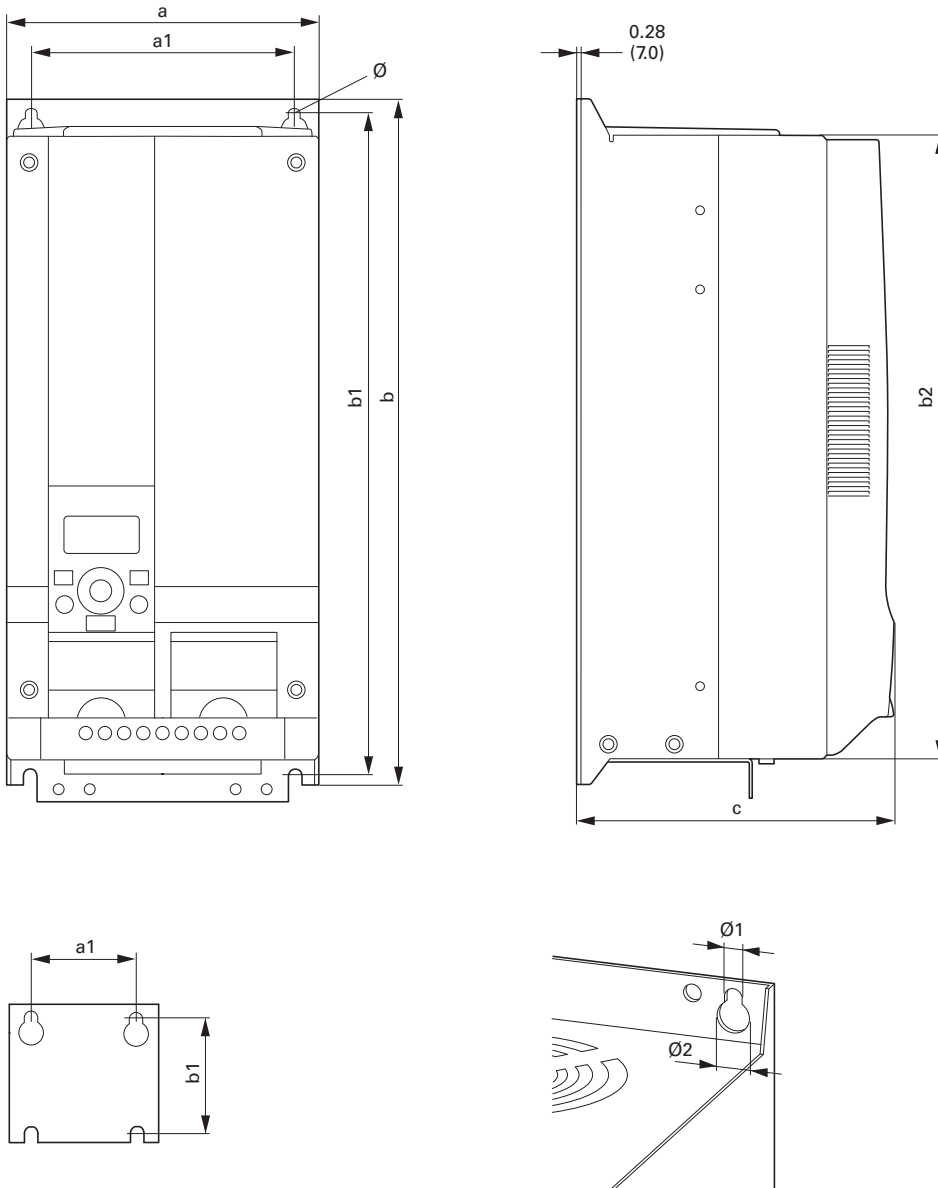

2.3

Adjustable Frequency Drives

M-Max Series Drives

Dimensions and Frame Sizes

Approximate Dimensions in inches (mm)

Part Number	a	a1	b	b1	b2	c	Ø, Ø1	Ø2	Installation Size
MMX12AA1D7_	2.60	1.50	6.30	5.79	1.26	4.02	0.18	—	FS1
MMX12AA2D4_	(66)	(38)	(160)	(147)	(32)	(102)	(4.5)		
MMX12AA2D8_									
MMX32AA1D7_									
MMX32AA2D4_									
MMX32AA2D8_									
MMX34AA1D3_									
MMX34AA1D9_									
MMX34AA2D4_									
MMX11AA1D7_	3.54	2.46	7.68	7.17	1.26	4.14	2.17	—	FS2
MMX11AA2D4_	(90)	(62.5)	(195)	(182)	(32)	(105)	(5.5)		
MMX11AA2D8_									
MMX11AA3D7_									
MMX12AA3D7_									
MMX12AA4D8_									
MMX12AA7D0_									
MMX32AA3D7_									
MMX32AA4D8_									
MMX32AA7D0_									
MMX34AA3D3_									
MMX34AA4D3_									
MMX34AA5D6_									
MMX11AA4D8_	3.94	2.95	9.96	9.53	1.34	4.41	2.17	—	
MMX12AA9D6_	(100)	(75)	(253)	(242)	(34)	(112)	(5.5)		
MMX32AA011_									
MMX34AA7D6_									
MMX34AA9D0_									
MMX34AA012_									
MMX34AA014_									
MMX35AA1D7_									
MMX35AA2D7_									
MMX35AA3D9_									
MMX35AA6D1_									
MMX35AA9D0_									
MMX32AA012_	6.50	5.51	14.57	13.82	13.27	6.61	0.28	0.55	
MMX32AA017_	(165.0)	(140.0)	(370.0)	(351.0)	(337.0)	(168.0)	(7.0)	(14.0)	
MMX32AA025_									
MMX34AA016_									
MMX34AA023_									
MMX32AA031_	6.50	5.51	14.57	13.82	15.08	8.07	0.28	0.55	FS5
MMX32AA038_	(165.0)	(140.0)	(414.0)	(398.0)	(383.0)	(205.0)	(7.0)	(14.0)	
MMX34AA031_									
MMX34AA038_									

Note

1 in = 25.4 mm, 1 mm = 0.0394 in

Approximate Dimensions in Inches (mm)

NEMA 1/IP21 M-Max Drives and Communication Adapter Kit

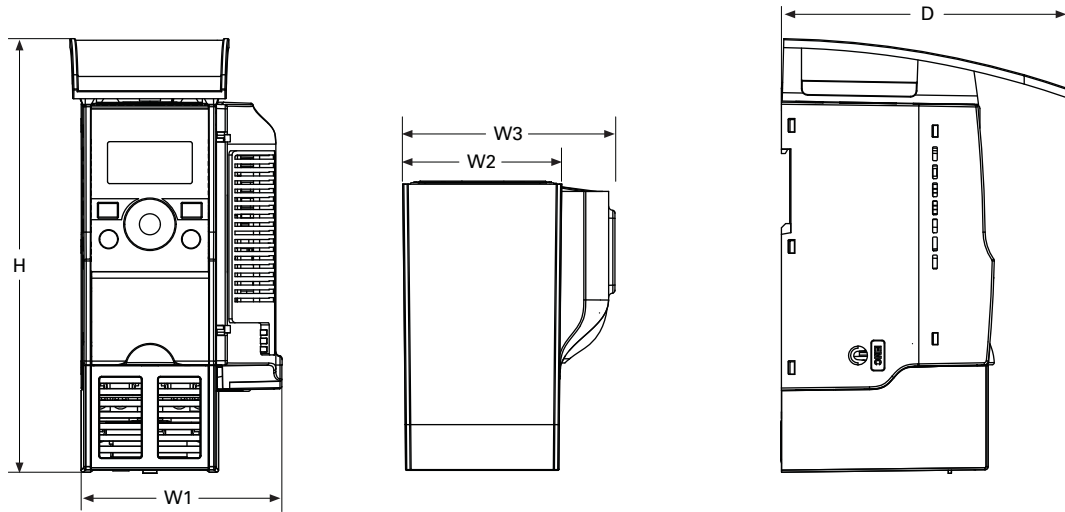

Frame Type	H	W1	W2	W3	D
FS1	8.14 (206.7)	3.77 (95.7)	2.99 (75.9)	3.98 (101.2)	5.41 (137.5)
FS2	9.90 (251.5)	4.72 (120.0)	3.97 (100.8)	4.94 (125.5)	5.68 (144.2)
FS3	12.26 (311.5)	5.12 (130.1)	4.36 (110.8)	5.33 (135.3)	6.32 (160.5)

DG1 General Purpose Drive

2



Product Description

The DG1 general purpose drives are part of Eaton’s next generation PowerXL Series of adjustable frequency drives specifically engineered for today’s more demanding commercial and industrial applications. The power unit makes use of the most sophisticated semiconductor technology and a highly modular construction that can be flexibly adapted to meet the customer’s needs.

The control module was designed to include today’s standard communication protocols and I/O while still having the modularity to add additional option cards.

Eaton’s patented Active Energy Control is also a standard feature on DG1 drives, offering customers increased efficiency, safety and reliability.

These drives continue the tradition of robust performance and raise the bar on features and functionality, ensuring the best solution at the right price.

Product Range

- 230V to 125 hp, 310A, 90 kW
- 480V to 250 hp, 310A, 160 kW
- 575V to 250 hp, 250A, 160 kW

Features and Benefits

Hardware

- Brake chopper standard on Frames 1, 2, 3
- Dual overload ratings
 - 110% variable torque (I_L)
 - 150% constant torque (I_H)
- Type 1/IP21 and Type 12/IP54 enclosures available
- Integrated common mode reduction 5% DC link choke with input surge protection
- EMI/RFI filters standard on all drives—meets EMC Category C2
- Real-time clock—supports calendaring and PLC functionality
- Graphic LCD display and keypad—supports simple menu navigation as well as on-screen diagnostics and troubleshooting
- LOCAL/REMOTE operation from keypad and two configurable soft keys

Contents

Description

Description	Page
PowerXL DG1 Series Drives	
Standards and Certifications	V6-T2-31
Catalog Number Selection	V6-T2-31
Product Selection	V6-T2-32
Accessories	V6-T2-34
Replacement Parts	V6-T2-38
Technical Data and Specifications	V6-T2-40
Dimensions	V6-T2-44

Software

- Control logic can be powered from an external auxiliary control panel—internal drive functions and fieldbus if necessary
- Standard I/O:
 - 8DI, 1DO
 - 2AI, 2AO
 - Three relays
 - Meets needs of most communication requirements
- Standard communications:
 - EtherNet/IP, Modbus TCP
 - RS-485: Modbus RTU, BACnet MS/TP
 - Meets the needs of most communication requirements
- Seamless integration into EtherNet/IP networks via EIP-Assist I/O tag-generation tool
- Two expansion slots—intended to support additional I/O or communication protocols as necessary
- Quick disconnect terminals for I/O connections—supports fast easy installation
- Active energy control—minimizes energy losses in your motor, resulting in industry-leading energy efficiency for your application
- Quick Start Wizard upon initial power-up supports fast, easy installation
- Standard applications:
 - Standard
 - Multi-pump and fan Control
 - Multi-PID
 - Multi-purpose
- Copy/paste functionality on drive keypad—allows for fast setup of multiple drives
- Pre-programmed I/O—supports fast, easy installation for most applications
- Dynamic motor regenerative energy management
- Advanced PC Tool with diagnostic capabilities
- Two configurable keypad soft keys

Standards and Certifications

Product

- IEC/EN 61800-5-1
- IEC/EN 61800-5-2
- UL 508C
- IEC 61508
- EN 62061
- EN ISO 13849-1

EMC

- Immunity: IEC/EN 61800-3
- Category C2

Certification

- UL
- cUL
- CE
- C-Tick
- RoHS



Catalog Number Selection

PowerXL Series—DG1 General Purpose Drive

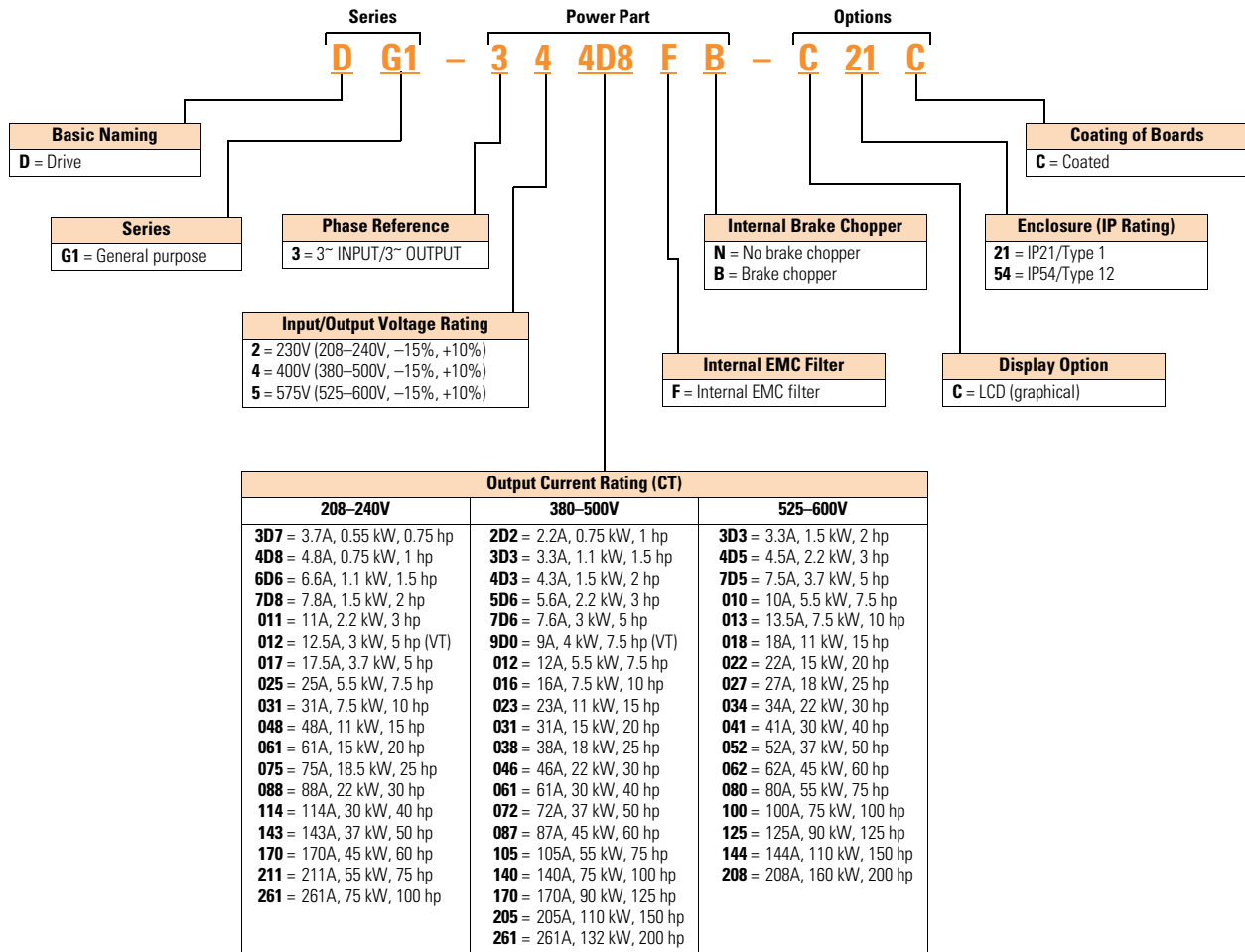

PowerXL Series—DG1 General Purpose Drive Option Boards

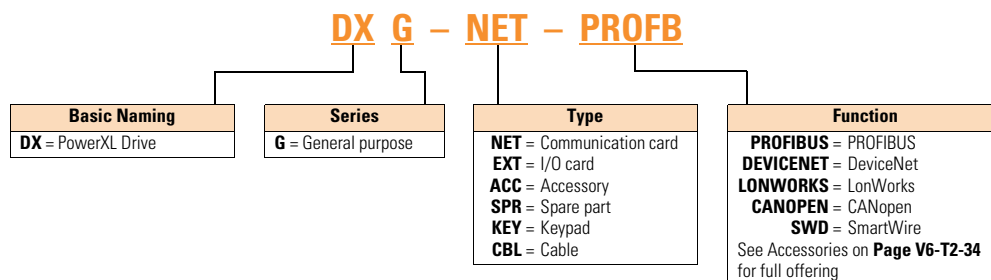

2.4

Adjustable Frequency Drives

PowerXL DG1 Series Drives

Product Selection

2

DG1 Series Drives—208–240 Volt

PowerXL Series—DG1

Type 1/IP21



Frame Size	230V, 50 Hz kW Rating (CT/I _H)	230V, 50 Hz kW Rating (VT/I _L)	230V, 60 Hz hp (CT/I _H)	230V, 60 Hz hp (VT/I _L)	Current A (CT/I _H)	Current A (VT/I _L)	Catalog Number
FR1	0.55	0.75	0.75	1	3.7	4.8	DG1-323D7FB-C21C
	0.75	1.1	1	1.5	4.8	6.6	DG1-324D8FB-C21C
	1.1	1.5	1.5	2	6.6	7.8	DG1-326D6FB-C21C
	1.5	2.2	2	3	7.8	11	DG1-327D8FB-C21C
	2.2	3	3	—	11	12.5	DG1-32011FB-C21C
FR2	3	3.7	—	5	12.5	17.5	DG1-32012FB-C21C
	3.7	5.5	5	7.5	17.5	25	DG1-32017FB-C21C
	5.5	7.5	7.5	10	25	31	DG1-32025FB-C21C
FR3	7.5	11	10	15	31	48	DG1-32031FB-C21C
	11	15	15	20	48	61	DG1-32048FB-C21C
FR4	15	18.5	20	25	61	75	DG1-32061FN-C21C
	18.5	22	25	30	75	88	DG1-32075FN-C21C
	22	30	30	40	88	114	DG1-32088FN-C21C
FR5	30	37	40	50	114	143	DG1-32114FN-C21C
	37	45	50	60	143	170	DG1-32143FN-C21C
	45	55	60	75	170	211	DG1-32170FN-C21C
FR6 ①	55	75	75	100	211	261	DG1-32211FN-C21C
	75	90	100	125	261	312	DG1-32261FN-C21C

PowerXL Series—DG1

Type 12/IP54



Frame Size	230V, 50 Hz kW Rating (CT/I _H)	230V, 50 Hz kW Rating (VT/I _L)	230V, 60 Hz hp (CT/I _H)	230V, 60 Hz hp (VT/I _L)	Current A (CT/I _H)	Current A (VT/I _L)	Catalog Number
FR1	0.55	0.75	0.75	1	3.7	4.8	DG1-323D7FB-C54C
	0.75	1.1	1	1.5	4.8	6.6	DG1-324D8FB-C54C
	1.1	1.5	1.5	2	6.6	7.8	DG1-326D6FB-C54C
	1.5	2.2	2	3	7.8	11	DG1-327D8FB-C54C
	2.2	3	3	—	11	12.5	DG1-32011FB-C54C
FR2	3	3.7	—	5	12.5	17.5	DG1-32012FB-C54C
	3.7	5.5	5	7.5	17.5	25	DG1-32017FB-C54C
	5.5	7.5	7.5	10	25	31	DG1-32025FB-C54C
FR3	7.5	11	10	15	31	48	DG1-32031FB-C54C
	11	15	15	20	48	61	DG1-32048FB-C54C
FR4	15	18.5	20	25	61	75	DG1-32061FN-C54C
	18.5	22	25	30	75	88	DG1-32075FN-C54C
	22	30	30	40	88	114	DG1-32088FN-C54C
FR5	30	37	40	50	114	143	DG1-32114FN-C54C
	37	45	50	60	143	170	DG1-32143FN-C54C
	45	55	60	75	170	211	DG1-32170FN-C54C
FR6 ①	55	75	75	100	211	261	DG1-32211FN-C54C
	75	90	100	125	261	312	DG1-32261FN-C54C

Note

① FR6 available in 2015.

DG1 Series Drives—380–500 Volt

PowerXL Series—DG1

Type 1/IP21



Frame Size	400V, 50 Hz kW Rating (CT/I _H)	400V, 50 Hz kW Rating (VT/I _L)	460V, 60 Hz hp (CT/I _H)	460V, 60 Hz hp (VT/I _L)	Current A (CT/I _H)	Current A (VT/I _L)	Catalog Number
FR1	0.75	1.1	1	1.5	2.2	3.3	DG1-342D2FB-C21C
	1.1	1.5	1.5	2	3.3	4.3	DG1-343D3FB-C21C
	1.5	2.2	2	3	4.3	5.6	DG1-344D3FB-C21C
	2.2	3	3	5	5.6	7.6	DG1-345D6FB-C21C
	3	4	5	—	7.6	9	DG1-347D6FB-C21C
	4	5.5	—	7.5	9	12	DG1-349D0FB-C21C
FR2	5.5	7.5	7.5	10	12	16	DG1-34012FB-C21C
	7.5	11	10	15	16	23	DG1-34016FB-C21C
	11	15	15	20	23	31	DG1-34023FB-C21C
FR3	15	18.5	20	25	31	38	DG1-34031FB-C21C
	18.5	22	25	30	38	46	DG1-34038FB-C21C
	22	30	30	40	46	61	DG1-34046FB-C21C
FR4	30	37	40	50	61	72	DG1-34061FN-C21C
	37	45	50	60	72	87	DG1-34072FN-C21C
	45	55	60	75	87	105	DG1-34087FN-C21C
FR5	55	75	75	100	105	140	DG1-34105FN-C21C
	75	90	100	125	140	170	DG1-34140FN-C21C
	90	110	125	150	170	205	DG1-34170FN-C21C
FR6 ①	110	132	150	200	205	261	DG1-34205FN-C21C
	132	160	200	250	261	310	DG1-34261FN-C21C

PowerXL Series—DG1

Type 12/IP54



Frame Size	400V, 50 Hz kW Rating (CT/I _H)	400V, 50 Hz kW Rating (VT/I _L)	460V, 60 Hz hp (CT/I _H)	460V, 60 Hz hp (VT/I _L)	Current A (CT/I _H)	Current A (VT/I _L)	Catalog Number
FR1	0.75	1.1	1	1.5	2.2	3.3	DG1-342D2FB-C54C
	1.1	1.5	1.5	2	3.3	4.3	DG1-343D3FB-C54C
	1.5	2.2	2	3	4.3	5.6	DG1-344D3FB-C54C
	2.2	3	3	5	5.6	7.6	DG1-345D6FB-C54C
	3	4	5	—	7.6	9	DG1-347D6FB-C54C
	4	5.5	—	7.5	9	12	DG1-349D0FB-C54C
FR2	5.5	7.5	7.5	10	12	16	DG1-34012FB-C54C
	7.5	11	10	15	16	23	DG1-34016FB-C54C
	11	15	15	20	23	31	DG1-34023FB-C54C
FR3	15	18.5	20	25	31	38	DG1-34031FB-C54C
	18.5	22	25	30	38	46	DG1-34038FB-C54C
	22	30	30	40	46	61	DG1-34046FB-C54C
FR4	30	37	40	50	61	72	DG1-34061FN-C54C
	37	45	50	60	72	87	DG1-34072FN-C54C
	45	55	60	75	87	105	DG1-34087FN-C54C
FR5	55	75	75	100	105	140	DG1-34105FN-C54C
	75	90	100	125	140	170	DG1-34140FN-C54C
	90	110	125	150	170	205	DG1-34170FN-C54C
FR6 ①	110	132	150	200	205	261	DG1-34205FN-C54C
	132	160	200	250	261	310	DG1-34261FN-C54C

Note

① FR6 available in 2015.

2.4

Adjustable Frequency Drives

PowerXL DG1 Series Drives

Accessories

2

The PowerXL Series—DG1 drives can accommodate a wide selection of expander and adapter option boards to customize the drive for your application needs. The drive's control unit is designed to accept a total of two additional option boards.

The PowerXL Series—DG1 drives come with a factory-installed standard board configuration including the following:

- Standard I/O:
 - 8DI, 1DO
 - 2AI, 2AO
 - Three relays
- Standard communications:
 - EtherNet/IP, Modbus TCP
 - RS-485: Modbus RTU, BACnet MS/TP

PowerXL Series—DG1 I/O Card Kits

Description	Catalog Number
3 x DI, 3 x DO, 1 x thermistor, 24 Vdc/EXT option card	DXG-EXT-3DI3DO1T
1 x AI, 2 x AO (isolated to control board) option card	DXG-EXT-1AI2AO
3 x relay dry contact (2NO + 1NO/NC) option card	DXG-EXT-3RO
3 x PT100 RTD thermistor input option card	DXG-EXT-THER1
6 x DI 240 Vac input option card	DXG-EXT-6DI

PowerXL Series—DG1 Communication Card Kits

Description	Catalog Number
PROFIBUS-DP communication card	DXG-NET-PROFIBUS
CANopen communication card	DXG-NET-CANOPEN
DeviceNet communication card	DXG-NET-DEVICENET
PROFIBUS DB9 to 5-pin adapter card	DXG-MNT-PROFIBUS
SmartWire communication card and module	DXG-NET-SWD
LonWorks communication card	DXG-NET-LONWORKS

PowerXL Series—DG1 Keypad Kits

Description	Catalog Number
Standard keypad	DXG-KEY-LCD
Remote keypad kit (0.5m cable)	DXG-KEY-RMTKIT
1m remote keypad cable	DXG-CBL-1M0
3m remote keypad cable	DXG-CBL-3M0
Remote keypad mounting holder only	DXG-KEY-HOLDER
Type 12/IP54 keypad hole plug (maintain rating without keypad)	DXG-KEY-N12PLUG

PowerXL Series—DG1 Conversion and Flange Kits

The Type 12/IP54 option kit is used to convert a Type 1/IP21 to a Type 12/IP54 drive. The kit includes cover, fan and grommets.

Type 12/IP54 Conversion Kits

Description	Catalog Number
Frame 1 230V Type 12/IP54 kit	DXG-ACC-2FR1N12KIT
Frame 1 480V Type 12/IP54 kit	DXG-ACC-4FR1N12KIT
Frame 2 Type 12/IP54 kit	DXG-ACC-FR2N12KIT
Frame 3 Type 12/IP54 kit	DXG-ACC-FR3N12KIT

The flange kit is used when the power section heat sink is mounted through the back panel of an enclosure. The kit includes hardware, top flange plate, bottom flange plate and two side flange plates.

Flange Kits

Description	Catalog Number
Frame 1 flange kit Type 12/IP54	DXG-ACC-FR1N12FK
Frame 2 flange kit Type 12/IP54	DXG-ACC-FR2N12FK
Frame 3 flange kit Type 12/IP54	DXG-ACC-FR3N12FK
Frame 4 flange kit Type 12/IP54	DXG-ACC-FR4N12FK
Frame 5 flange kit Type 12/IP54	DXG-ACC-FR5N12FK

PowerXL Series—DG1 Demo Units

Demo Units

Description	Catalog Number
DG1 control module demo stand	DG1-DEMO1
DG1 full drive demo case	DG1-DEMO2

PowerXpert inControl Software

The PowerXL Series PC Tool is designed for programming, controlling and monitoring of the DG1 drives. Features include loading parameters that can be saved to a file or printed, setting references, starting and stopping the motor, monitoring signals in graphical or text form, and real-time display.

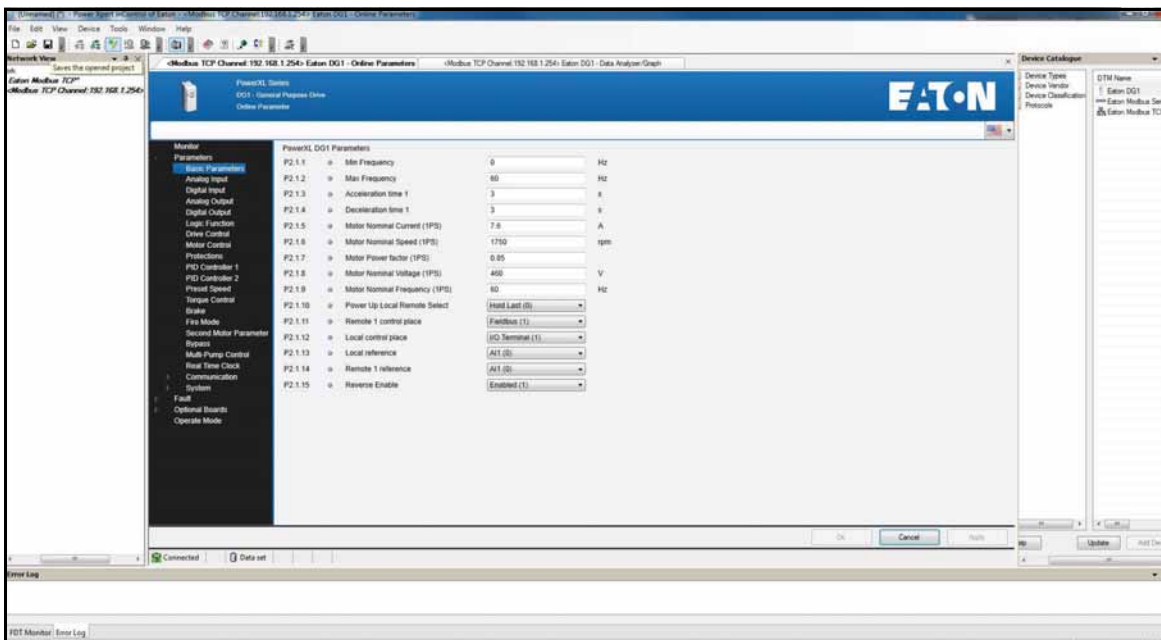
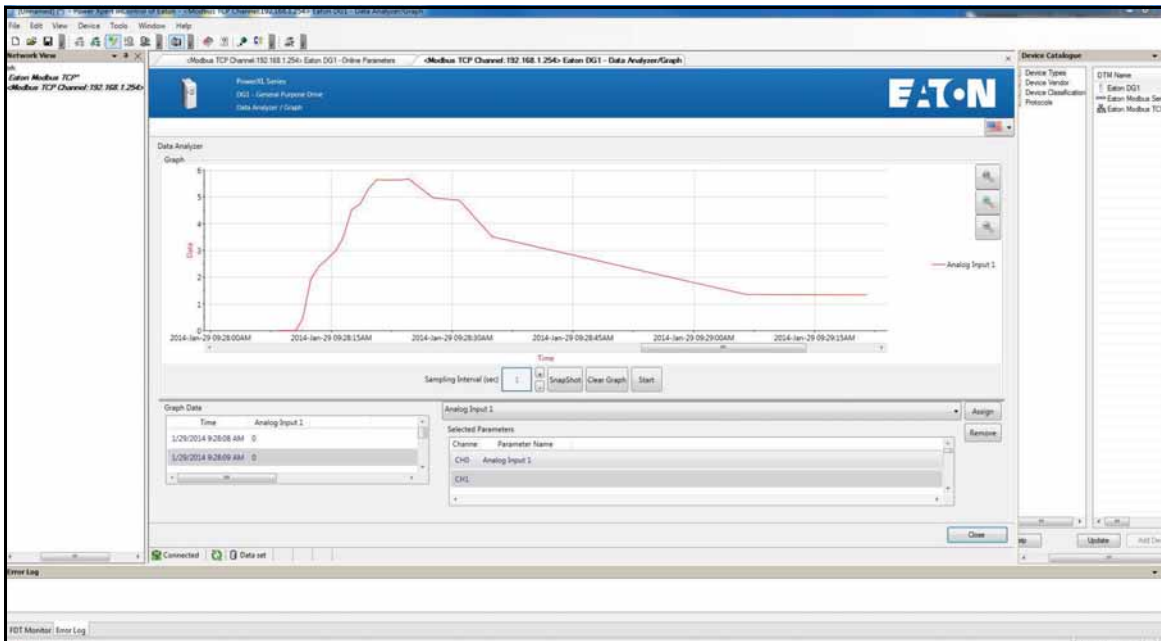

PowerXpert inControl Software

Description	Catalog Number
Software kit (software, cable, manual)	DXG-ACC-SOFTWARE
Software cable (USB to RJ45 [RS-485])	DXG-CBL-PCCABLE
Real-time clock battery	DXG-ACC-RTBATT

2.4

Adjustable Frequency Drives

PowerXL DG1 Series Drives

2

Brake Chopper Options

The brake chopper circuit option is used for applications that require dynamic braking. Dynamic braking resistors are not included with drive purchase. Consult the factory for additional dynamic braking resistor selections that are supplied separately. A list of common resistors are listed below and are complete indoor assemblies, include a pre-wired terminal block and a thermal switch, and are not UL Listed.

Duty Cycle

The duty cycle rating is based on a 60-second period. For example, the 20% duty cycle resistor can carry 100% current for 12 seconds out of every 60 seconds, while the 50% duty cycle resistor can carry 150% current for 30 seconds out of every 60 seconds.

Torque

If the braking torque required is less than 15%, dynamic braking is not required because the regenerated energy will be dissipated in the drive and motor losses.

Dynamic Brake Resistor—Catalog Number Selection

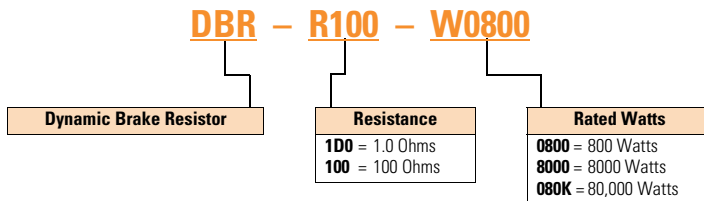

230V Brake Resistors

Drive hp (CT/l _H)	Minimum Ohms	20% Duty Cycle, 100% Torque		50% Duty Cycle, 150% Torque	
		Catalog Number	Dimensions	Catalog Number	Dimensions
0.75	15.0	DBR-R100-W0400	12W x 5D x 5H	DBR-R100-W0800	12W x 7D x 5H
1	15.0	DBR-R100-W0400	12W x 5D x 5H	DBR-R100-W0800	12W x 7D x 5H
1.5	15.0	DBR-R100-W0400	12W x 5D x 5H	DBR-R036-W1200	12W x 10D x 5H
2	15.0	DBR-R100-W0400	12W x 5D x 5H	DBR-R036-W1200	12W x 10D x 5H
3	15.0	DBR-R036-W0800	12W x 7D x 5H	DBR-R036-W2000	12W x 16D x 5H
4	9.0	DBR-R036-W0800	12W x 7D x 5H	DBR-R012-W2400	19W x 10D x 5H
5	9.0	DBR-R036-W0800	12W x 7D x 5H	DBR-R020-W2800	19W x 13D x 5H
7.5	9.0	DBR-R020-W1200	12W x 10D x 5H	DBR-R012-W4800	26.5W x 10D x 5H
10	7.0	DBR-R015-W1600	12W x 13D x 5H	DBR-R112-W6000	26.5W x 13D x 5H
15	7.0	DBR-R012-W2400	19W x 10D x 5H	DBR-R7D8-W9000	28W x 10D x 10H
20	2.0	DBR-R9D3-W3200	19W x 10D x 5H	DBR-R3D4-W012K	28W x 10D x 10H
25	2.0	DBR-R5D5-W4000	26.5W x 10D x 5H	DBR-R5D1-W015K	28W x 16D x 10H
30	2.0	DBR-R4D8-W4800	26.5W x 10D x 5H	DBR-R4D1-W020K	28W x 16D x 10H
40	2.0	DBR-R004-W6000	26.5W x 13D x 5H	DBR-R3D4-W025K	30W x 18D x 16H
50	2.0	DBR-R3D1-W7500	26.5W x 16D x 5H	DBR-R2D1-W030K	30W x 18D x 24H
60	2.0	DBR-R2D8-W9000	26.5W x 16D x 5H	DBR-R002-W036K	30W x 18D x 24H
75	2.0	DBR-R2D6-W012K	28W x 10D x 10H	DBR-R002-W045K	30W x 18D x 32H
100	2.0	DBR-R002-W015K	28W x 16D x 10H	DBR-R002-W060K	30W x 18D x 48H

480V Brake Resistors

Drive hp (CT/l _H)	Minimum Ohms	20% Duty Cycle, 100% Torque		50% Duty Cycle, 150% Torque	
		Catalog Number	Dimensions	Catalog Number	Dimensions
1	36.0	DBR-R100-W0400	12W x 5D x 5H	DBR-R100-W0800	12W x 7D x 5H
1.5	36.0	DBR-R100-W0400	12W x 5D x 5H	DBR-R100-W1200	12W x 10D x 5H
2	36.0	DBR-R100-W0400	12W x 5D x 5H	DBR-R100-W1200	12W x 10D x 5H
3	36.0	DBR-R100-W0800	12W x 7D x 5H	DBR-R100-W2000	12W x 16D x 5H
5	36.0	DBR-R100-W0800	12W x 7D x 5H	DBR-R100-W2800	19W x 13D x 5H
6	36.0	DBR-R100-W1200	12W x 10D x 5H	DBR-R070-W4000	19W x 16D x 5H
7.5	18.0	DBR-R100-W1200	12W x 10D x 5H	DBR-R020-W4800	26.5W x 13D x 5H
10	18.0	DBR-R063-W1600	12W x 13D x 5H	DBR-R030-W6000	26.5W x 16D x 5H
15	18.0	DBR-R030-W2400	19W x 10D x 5H	DBR-R030-W9000	28W x 10D x 10H
20	13.0	DBR-R030-W3200	19W x 13D x 5H	DBR-R023-W012K	28W x 13D x 10H
25	13.0	DBR-R030-W4000	19W x 16D x 5H	DBR-R013-W015K	28W x 16D x 10H
30	13.0	DBR-R020-W4800	26.5W x 13D x 5H	DBR-R014-W020K	30W x 18D x 24H
40	2.0	DBR-R112-W6000	26.5W x 13D x 5H	DBR-R007-W025K	30W x 18D x 16H
50	2.0	DBR-R013-W7500	26.5W x 16D x 5H	DBR-R8D5-W030K	30W x 18D x 24H
60	2.0	DBR-R010-W9000	28W x 10D x 10H	DBR-R7D3-W036K	30W x 18D x 24H
75	2.0	DBR-R009-W012K	28W x 13D x 10H	DBR-R002-W045K	30W x 18D x 32H
100	2.0	DBR-R5D1-W015K	28W x 16D x 10H	DBR-R004-W060K	30W x 18D x 40H
125	2.0	DBR-R4D1-W020K	28W x 16D x 10H	DBR-R004-W070K	30W x 18D x 48H
150	2.0	DBR-R3D4-W025K	30W x 18D x 16H	DBR-R3D5-W085K	30W x 18D x 56H
200	2.0	DBR-R3D3-W030K	30W x 18D x 24H	DBR-R2D6-W110K	30W x 18D x 64H

Replacement Parts

2

Frame 1

Description	Catalog Number 230V	Catalog Number 480V	Catalog Number 575V
Standard keypad ①	DXG-KEY-LCD	DXG-KEY-LCD	DXG-KEY-LCD
Main control board ①	DXG-SPR-CTRLBOARD	DXG-SPR-CTRLBOARD	DXG-SPR-CTRLBOARD
Control board cover	DXG-SPR-BCOVER	DXG-SPR-BCOVER	DXG-SPR-BCOVER
Type 1/IP21 standard cover	DXG-SPR-FR1CVR	DXG-SPR-FR1CVR	②
Main fan kit ①	DXG-SPR-FR1FAN	DXG-SPR-FR1FAN	②
Control fan	DXG-SPR-2FR1CF	DXG-SPR-4FR1CF	②
Main power board	DXG-SPR-2FR1MPB	DXG-SPR-4FR1MPB	②
EMI board	DXG-SPR-2FR1EB	DXG-SPR-4FR1EB	②
Middle chassis cover	DXG-SPR-FR1MCC	DXG-SPR-FR1MCC	②
Outer housing	DXG-SPR-FR1OH	DXG-SPR-FR1OH	②
UL conduit plate	DXG-SPR-FR1CPUL	DXG-SPR-FR1CPUL	②
IEC conduit plate	DXG-SPR-FR1CPIEC	DXG-SPR-FR1CPIEC	②

Frame 2

Description	Catalog Number 230V	Catalog Number 480V	Catalog Number 575V
Standard keypad ①	DXG-KEY-LCD	DXG-KEY-LCD	DXG-KEY-LCD
Main control board ①	DXG-SPR-CTRLBOARD	DXG-SPR-CTRLBOARD	DXG-SPR-CTRLBOARD
Control board cover	DXG-SPR-BCOVER	DXG-SPR-BCOVER	DXG-SPR-BCOVER
Type 1/IP21 standard cover	DXG-SPR-FR2CVR	DXG-SPR-FR2CVR	②
Main fan kit ①	DXG-SPR-FR2FAN	DXG-SPR-FR2FAN	②
Control fan	DXG-SPR-FR2CF	DXG-SPR-FR2CF	②
Bus capacitor	DXG-SPR-2FR2BC	DXG-SPR-4FR24BC	②
Main power board	DXG-SPR-2FR2MPB	DXG-SPR-4FR2MPB	②
EMI board	DXG-SPR-2FR2EB	DXG-SPR-4FR2EB	②
IGBT module	DXG-SPR-FR2IGBT	DXG-SPR-FR2IGBT	②
Middle chassis cover	DXG-SPR-FR2MCC	DXG-SPR-FR2MCC	②
Outer housing	DXG-SPR-FR2OH	DXG-SPR-FR2OH	②
UL conduit plate	DXG-SPR-FR2CPUL	DXG-SPR-FR2CPUL	②
IEC conduit plate	DXG-SPR-FR2CPIEC	DXG-SPR-FR2CPIEC	②

Frame 3

Description	Catalog Number 230V	Catalog Number 480V	Catalog Number 575V
Standard keypad ①	DXG-KEY-LCD	DXG-KEY-LCD	DXG-KEY-LCD
Main control board ①	DXG-SPR-CTRLBOARD	DXG-SPR-CTRLBOARD	DXG-SPR-CTRLBOARD
Control board cover	DXG-SPR-BCOVER	DXG-SPR-BCOVER	DXG-SPR-BCOVER
Type 1/IP21 standard cover	DXG-SPR-FR3CVR	DXG-SPR-FR3CVR	②
Main fan kit ①	DXG-SPR-FR3FAN	DXG-SPR-FR3FAN	②
Control fan	DXG-SPR-FR34CF	DXG-SPR-FR34CF	②
Bus capacitor	DXG-SPR-FR3BC	DXG-SPR-FR3BC	②
Main power board	DXG-SPR-2FR3MPB	DXG-SPR-4FR3MPB	②
EMI board	DXG-SPR-2FR3EB	DXG-SPR-4FR3EB	②
Drive board	DXG-SPR-2FR3DB	DXG-SPR-4FR3DB	②
Output board	DXG-SPR-FR3OB	DXG-SPR-FR3OB	②
Middle chassis cover	DXG-SPR-FR3MCC	DXG-SPR-FR3MCC	②
Outer housing	DXG-SPR-FR3OH	DXG-SPR-FR3OH	②
UL conduit plate	DXG-SPR-FR3CPUL	DXG-SPR-FR3CPUL	②
IEC conduit plate	DXG-SPR-FR3CPIEC	DXG-SPR-FR3CPIEC	②

Notes

① Factory recommended spare parts.

② 575V available in 2015.

Frame 4

Description	230V Catalog Number	480V Catalog Number	575V Catalog Number
Standard keypad ①	DXG-KEY-LCD	DXG-KEY-LCD	DXG-KEY-LCD
Main control board ①	DXG-SPR-CTRLBOARD	DXG-SPR-CTRLBOARD	DXG-SPR-CTRLBOARD
Control board cover	DXG-SPR-BCOVER	DXG-SPR-BCOVER	DXG-SPR-BCOVER
Type 1/IP21 standard cover	DXG-SPR-FR4CVR	DXG-SPR-FR4CVR	②
Main fan kit ①	DXG-SPR-FR4FAN	DXG-SPR-FR4FAN	②
Control fan	DXG-SPR-FR34CF	DXG-SPR-FR34CF	②
Bus capacitor	DXG-SPR-2FR4BC	DXG-SPR-4FR24BC	②
Main power board	DXG-SPR-2FR4MPB	DXG-SPR-4FR4MPB	②
EMI board	DXG-SPR-2FR4EB	DXG-SPR-4FR4EB	②
Softstart board	DXG-SPR-2FR4SB	DXG-SPR-4FR4SB	②
IGBT module	DXG-SPR-2FR4IGBT	DXG-SPR-4FR4IGBT	②
Rectifier module	DXG-SPR-2FR4RM	DXG-SPR-4FR4RM	②
Brake chopper module	DXG-SPR-2FR4BCM	DXG-SPR-4FR4BCM	②
Middle chassis cover	DXG-SPR-FR4MCC	DXG-SPR-FR4MCC	②
Outer housing	DXG-SPR-FR40H	DXG-SPR-FR40H	②
UL conduit plate	DXG-SPR-FR4CPUL	DXG-SPR-FR4CPUL	②
IEC conduit plate	DXG-SPR-FR4CPIEC	DXG-SPR-FR4CPIEC	②

Frame 5

Description	230V Catalog Number	480V Catalog Number	575V Catalog Number
Standard keypad ①	DXG-KEY-LCD	DXG-KEY-LCD	DXG-KEY-LCD
Main control board ①	DXG-SPR-CTRLBOARD	DXG-SPR-CTRLBOARD	DXG-SPR-CTRLBOARD
Control board cover	DXG-SPR-BCOVER	DXG-SPR-BCOVER	DXG-SPR-BCOVER
Type 1/IP21 standard cover	DXG-SPR-FR5CVR	DXG-SPR-FR5CVR	②
Main fan kit ①	DXG-SPR-FR5FAN	DXG-SPR-FR5FAN	②
Control fan	DXG-SPR-FR5CF	DXG-SPR-FR5CF	②
Bus capacitor	DXG-SPR-FR5BC	DXG-SPR-FR5BC	②
Main power board	DXG-SPR-2FR5MPB	DXG-SPR-4FR5MPB	②
EMI-1 board	DXG-SPR-2FR5E1B	DXG-SPR-4FR5E1B	②
EMI-2 board	DXG-SPR-2FR5E2B	DXG-SPR-4FR5E2B	②
EMI-3 board	DXG-SPR-FR5E3B	DXG-SPR-FR5E3B	②
IGBT module	DXG-SPR-FR5IGBT	DXG-SPR-FR5IGBT	②
Rectifier module	DXG-SPR-2FR5RM	DXG-SPR-4FR5RM	②
Brake chopper module	DXG-SPR-2FR5BCM	DXG-SPR-4FR5BCM	②
Middle chassis cover	DXG-SPR-FR5MCC	DXG-SPR-FR5MCC	②
Outer housing	DXG-SPR-FR50H	DXG-SPR-FR50H	②
UL conduit plate	DXG-SPR-FR5CPUL	DXG-SPR-FR5CPUL	②
IEC conduit plate	DXG-SPR-FR5IECCP	DXG-SPR-FR5IECCP	②

Notes

① Factory recommended spare parts.

② 575V available in 2015.

Technical Data and Specifications

2

PowerXL Series—DG1 Technical Data and Specifications

Attribute	Description	Specification	
Input ratings	Input voltage U_{in}	208V to 240V, 380V to 500V, 525V to 600V, –15 to 10%	
	Input frequency	50 Hz to 60 Hz (variation up to 45 Hz to 66 Hz)	
	Connection to power	Once per minute or less	
	Starting delay	3s (FR1 to FR2), 4s (FR3), 5s (FR4), 6s (FR5)	
	Short-circuit withstand rating	100 kAIC	
Output ratings	Output voltage	0 to U_{in}	
	Continuous output current	IL: ambient temperature maximum 40°C, up to 60°C with derating, overload 1.1 x IL (1 min./10 min.) IH: ambient temperature maximum 50°C, up to 60°C with derating, overload 1.5 x IH (1 min./10 min.)	
	Overload current	150% respectively 110% (1 min./10 min.)	
	Initial output current	200% (2s/20s)	
	Output frequency	0–400 Hz (standard)	
	Frequency resolution	0.01 Hz	
Control characteristics	Control methods	Frequency control Speed control Open-loop speed control Open-loop torque control	
	Switching frequency	Range: FR1–3: 1 kHz to 12 kHz FR4–5: 1 kHz to 10 kHz Defaults: FR1–3: 4 kHz (IH), 6 kHz (IL) FR4–5: 3.6 kHz Automatic switching frequency derating in case of overload.	
	Frequency reference	Analog input: resolution 0.1% (10-bit), accuracy +1% Panel reference: resolution 0.01 Hz	
	Field weakening point	20 Hz to 400 Hz	
	Acceleration time	0.1s to 3000s	
	Deceleration time	0.1s to 3000s	
	Braking torque	DC brake: 30% x Motor Rated Torque (T_n) (without brake chopper) Dynamic braking (with optional brake chopper using an external brake resistor): 100% continuous maximum rating	
	Ambient conditions	Ambient operating temperature	–10°C (no frost) to +50°C, up to +60°C with derating (CT) –10°C (no frost) to +40°C, up to +60°C with derating (VT)
		Storage temperature	–40°C to +70°C
		Relative humidity	0–95% RH, noncondensing, non-corrosive
Air quality: • Chemical vapors • Mechanical particles		Tested according to IEC 60068-2-60 Test Key: Flowing mixed gas corrosion test, Method 1 (H2S [hydrogen sulfide] and SO2 [sulfur dioxide]) Designed according to: IEC 60721-3-3, unit in operation, class 3C2 IEC 60721-3-3, unit in operation, class 3S2	
Altitude		100% load capacity (no derating) up to 3280 ft (1000m); 1% derating for each 328 ft (100m) above 3280 ft (1000m); max. 9842 ft (3000m) (2000m for corner grounded earth main systems)	

PowerXL Series—DG1 Technical Data and Specifications, continued

Attribute	Description	Specification
Ambient conditions, continued	Vibration:	5–150 Hz
	• EN 61800-5-1	Displacement amplitude: 1 mm (peak) at 5 Hz to 15.8 Hz (FR1–FR5)
	• EN 60668-2-6	Maximum acceleration amplitude: 1g at 15.8 Hz to 150 Hz (FR1–FR5)
	Shock:	Storage and shipping: maximum 15g, 11 ms (in package)
	• ISTA 1 A	
	• EN 60068-2-27	
	Overvoltage	Overvoltage Category III
	Pollution degree	Pollution Degree 2
	Enclosure class	IP21/Type 1 standard in entire kW/hp range IP54/Type 12 option Note: Keypad required to be mounted in drive for IP54/Type 12 rating
	Immunity	Fulfills EN 61800-3 (2004), first and second environment
MTBF	FR1: 165,457 hours FR2: 134,833 hours FR3: 102,515 hours FR4: 121,567 hours FR5: 108,189 hours FR6: Available in 2015	
Standards	Safety	UL 508C, CSA C22.2 No. 274-13 and EN 61800-5-1
	EMC	+EMC2: EN 61800-3 (2004), Category C2 The drive can be modified for IT networks and corner grounding TN system
	Electrostatic discharge	Second environment, IEC 61000-4-2, 4 kV CD or 8 kV AD, Criterion B
	Fast transient burst	Second environment, IEC 61000-4-4, 2 kV/5 kHz, Criterion B
	Dielectrical strength	Primary to secondary: 3600 Vac/5100 Vdc Primary to earth: 2000 Vac/2828 Vdc
	Approvals	EN 61800-5-1 (2007), CE, UL and cUL (see nameplate for more detailed approvals)
Fieldbus connections	Onboard: EtherNet/IP, Modbus [®] TCP, Modbus RTU, BACnet	
Safety/protections	Overvoltage protection	Yes
	Overvoltage trip limit	240V drives: 456V 480V drives: 911V
	Undervoltage protection	Yes
	Undervoltage trip limit	240V drives: 211V 480V drives: 370V
	Earth fault protection	Yes
	Input phase supervision	Yes
	Motor phase supervision	Yes
	Overcurrent protection	Yes
	Unit overtemperature protection	Yes
	Motor overload protection	Yes
	Motor stall protection	Yes
	Motor underload protection	Yes
	DC bus overvoltage control	Yes
	Short-circuit protection of 24V reference voltages	Yes
	Surge protection	Yes (differential mode 2 kV; common mode 4 kV)
	Common coated boards	Yes (prevents corrosion)

2.4

Adjustable Frequency Drives

PowerXL DG1 Series Drives

Wiring Diagram

2

PowerXL Series—DG1 Control Wiring Diagram

Pin	Signal Name	Signal	Default Setting	Description
1	+10V	Ref. Output Voltage	—	10 Vdc Supply Source
2	AI1+	Analog Input 1	0–10V	Voltage Speed Reference (Programmable to 4 mA to 20 mA)
3	AI1–	Analog Input 1 Ground	—	Analog Input 1 Common (Ground)
4	AI2+	Analog Input 2	4 mA to 20 mA	Current Speed Reference (Programmable to 0–10V)
5	AI2–	Analog Input 2 Ground	—	Analog Input 2 Common (Ground)
6	GND	I/O Signal Ground	—	I/O Ground for Reference and Control
7	DIN5	Digital Input 5	Preset Speed B0	Sets frequency output to Preset Speed 1
8	DIN6	Digital Input 6	Preset Speed B1	Sets frequency output to Preset Speed 2
9	DIN7	Digital Input 7	Emergency Stop (TI–)	Input forces VFD output to shut off
10	DIN8	Digital Input 8	Force Remote (TI+)	Input takes VFD from Local to Remote
11	CMB	DI5 to DI8 Common	Grounded	Allows source input
12	GND	I/O Signal Ground	—	I/O Ground for Reference and Control
13	24V	+24 Vdc Output	—	Control voltage output (100 mA max.)
14	DO1	Digital Output 1	Ready	Shows the drive is ready to run
15	24Vo	+24 Vdc Output	—	Control voltage output (100 mA max.)
16	GND	I/O Signal Ground	—	I/O Ground for Reference and Control
17	A01+	Analog Output 1	Output Frequency	Shows Output frequency to motor 0–60 Hz (4 mA to 20 mA)
18	A02+	Analog Output 2	Motor Current	Shows Motor current of motor 0–FLA (4 mA to 20 mA)
19	24Vi	+24 Vdc Input	—	External control voltage input
20	DIN1	Digital Input 1	Run Forward	Input starts drive in forward direction (start enable)
21	DIN2	Digital Input 2	Run Reverse	Input starts drive in reverse direction (start enable)
22	DIN3	Digital Input 3	External Fault	Input causes drive to fault
23	DIN4	Digital Input 4	Fault Reset	Input resets active faults
24	CMA	DI1 to DI4 Common	Grounded	Allows source input
25	A	RS-485 Signal A	—	Fieldbus Communication (Modbus, BACnet)
26	B	RS-485 Signal B	—	Fieldbus Communication (Modbus, BACnet)
27	R3NO	Relay 3 Normally Open	At Speed	Relay output 3 shows VFD is at Ref. Frequency
28	R1NC	Relay 1 Normally Closed	Run	Relay output 1 shows VFD is in a run state
29	R1CM	Relay 1 Common		
30	R1NO	Relay 1 Normally Open		
31	R3CM	Relay 3 Common	At Speed	Relay output 3 shows VFD is at Ref. Frequency
32	R2NC	Relay 2 Normally Closed	Fault	Relay output 2 shows VFD is in a fault state
33	R2CM	Relay 2 Common		
34	R2NO	Relay 2 Normally Open		

Control Board Layout

PowerXL Series—DG1 Control Board Layout

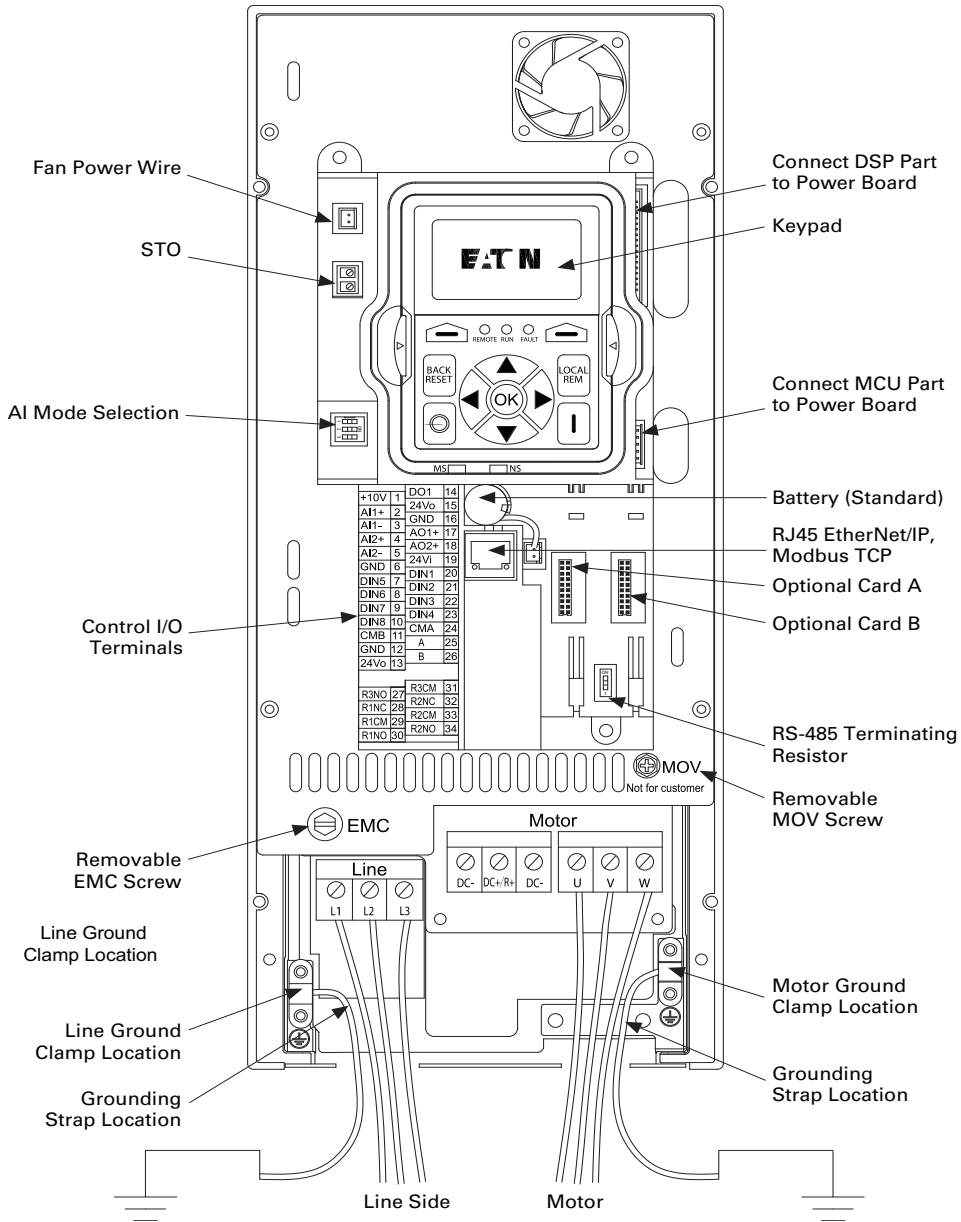

2.4

Adjustable Frequency Drives

PowerXL DG1 Series Drives

Dimensions

Approximate Dimensions in Inches (mm)

2

PowerXL Series—DG1 Dimensions

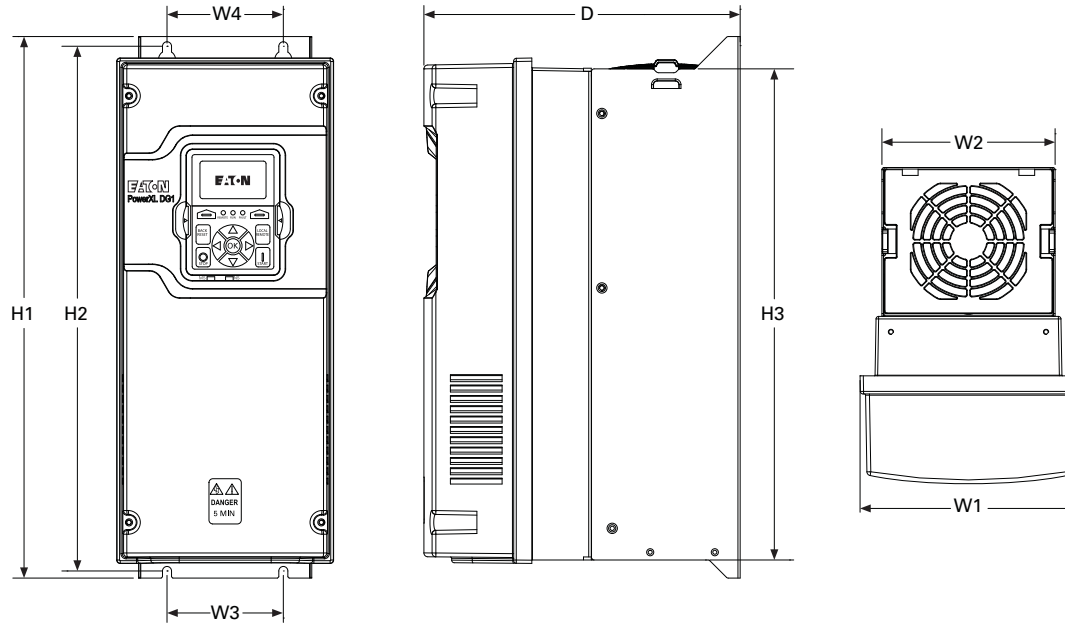

Frame Size	Voltage	hp (CT/I _H)	kW	Amperes (CT/I _H)	Approximate Dimensions in Inches (mm)								Weight Lb (kg)	
					D	H1	H2	H3	W1	W2	W3	W4		Ø
FR1	230 Vac	0.75–3	0.55–2.2	3.5–11	7.89	12.97	12.28	11.50	6.02	4.80	3.94	3.94	0.28	14.33
	480 Vac	1–5	0.75–3.7	2.3–7.6	(200.4)	(326.9)	(311.9)	(292.1)	(153.0)	(121.9)	(100.1)	(100.1)	(7.0)	(6.5)
	575 Vac ①	2–5	1.5–3.7	3.3–7.5										
FR2	230 Vac	5–7.5	3–5.5	12.5–25	9.63	16.50	15.98	14.96	6.61	5.28	3.54	3.54	0.28	23.37
	480 Vac	7.5–15	5.5–11	12–23	(244.7)	(419.1)	(405.9)	(380.0)	(167.8)	(134.1)	(90.0)	(90.0)	(7.0)	(10.6)
	575 Vac ①	7.5–15	5.5–11	10–18										
FR3	230 Vac	10–15	7.5–11	31–48	10.44	21.97	21.46	20.43	8.06	7.24	4.92	4.92	0.35	49.82
	480 Vac	20–30	15–22	31–46	(265.1)	(558.0)	(545.0)	(518.9)	(204.6)	(183.9)	(125.0)	(125.0)	(9.0)	(22.6)
	575 Vac ①	20–30	15–22	22–34										
FR4	230 Vac	20–30	15–22	61–88	11.57	24.80	34.31	23.27	9.36	9.13	8.07	8.07	0.35	77.60
	480 Vac	40–60	30–45	61–87	(294.0)	(629.9)	(617.5)	(591.1)	(237.7)	(231.9)	(205.0)	(205.0)	(9.0)	(35.2)
	575 Vac ①	40–60	30–45	41–62										
FR5	230 Vac	40–60	30–45	114–170	13.41	34.98	29.65	27.83	11.34	11.10	8.66	8.66	0.35	154.32
	480 Vac	75–125	55–90	105–170	(340.7)	(888.5)	(753.1)	(706.9)	(288.0)	(281.9)	(220.0)	(220.0)	(9.0)	(70.0)
	575 Vac ①	75–125	55–90	80–125										
FR6 ①	230 Vac	75–100	55–75	211–261	①	①	①	①	①	①	①	①	①	①
	480 Vac	150–200	110–150	205–261										
	575 Vac ①	150–200	110–160	144–208										

Note

① FR6 and 575 Vac available in 2015.

SVX9000 Drives

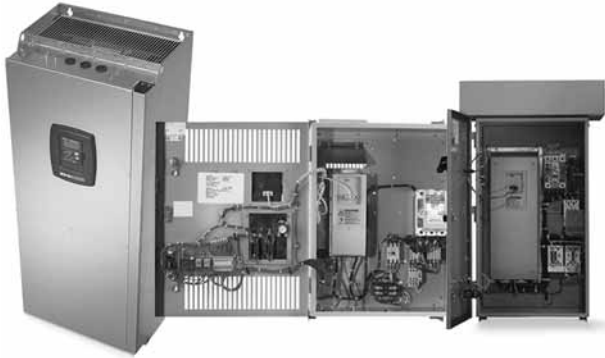

Contents

Description**Page**

SVX9000 Drives	
SVX9000 Drives	V6-T2-48
SVX9000 Enclosed Drives	V6-T2-87
SVX9000 VFD Pump Panels	V6-T2-111

Product Overview

With the SVX9000 Series Sensorless Vector Control, Eaton's expanded Eaton drive offering now covers a complete line of PWM adjustable frequency (speed) drives in ratings from:

- 208V—3/4 to 100 hp I_H ;
1 to 100 hp I_L
- 230V—3/4 to 100 hp I_H ;
1 to 125 hp I_L
- 480V—1 to 1900 hp I_H ;
1-1/2 to 2200 hp I_L
- 575V—2 to 2000 hp I_H ;
3 to 2300 hp I_L

The Eaton family of drives includes DA1, DC1, H-Max, M-Max, SVX9000 and SPX9000. 9000X Series drive ratings are rated for either high overload (I_H) or low overload (I_L). I_L indicates 110% overload capacity for 1 minute out of 10 minutes. I_H indicates 150% overload capacity for 1 minute out of 10 minutes.

A full range of enclosure types and options are available to meet a wide array of applications—from simple variable torque to more complex industrial applications such as conveyors, mixers and machine controls.

Application Description**Application Engineering**

Proper selection and application of all drive system components is essential to assure that an adjustable frequency drive system will safely and reliably provide the performance required for any given application. The party responsible for the overall design and operation of the facility must make sure that qualified personnel are employed to select all components of the drive system, including appropriate safety devices. Eaton's AF Drives Application Engineering Department is prepared to provide assistance to answer any questions about the technical capabilities of Eaton drives.

Motor Selection

The basic requirement of motor selection is to match the torque vs. speed capability of the motor to the torque vs. speed requirement of the driven load.

Motor Torque vs. Speed Capability

As the speed of a motor is reduced below its 60 Hz base speed, motor cooling becomes less effective because of the reduced speed of the self-cooling fan. This limitation determines the maximum torque for continuous operation at any operating speed. The maximum intermittent operating torque is determined by the motor's torque vs. current characteristics and the output current capability of the adjustable frequency controller.

Multiple Motor Operation

A number of motors can be connected in parallel to a single controller. Since the frequency of the power supplied by the controller is the same for each motor, the motors will always operate at the same speed. Application Engineering assistance must be requested for all multiple motor applications to assure compliance with all controller design limitations.

Special Types of Motors

Standard NEMA Designs A and B three-phase motors are the only motors recommended for use in the majority of applications, but other types of motors are occasionally used. If the existing motor used in the application or the motor proposed for use with the drive system is a type other than NEMA Design A or B, Application Engineering assistance must be requested to make certain that the drive is properly applied.

Product Selection Guide

Controller Selection

The basic requirement of controller selection is to match the output current, voltage and frequency capabilities of the controller with the requirements of the connected motor.

Output Current

The controller must be selected and applied such that the average operating motor current and horsepower do not exceed the continuous current and horsepower ratings of the controller. The intermittent operating current must not exceed the intermittent current rating of the controller.

Motor Protection

Eaton adjustable frequency drives include electronic motor overload protection circuits that are designed to meet the requirements of NEC article 430-2 provided that only one motor is connected to the output of the controller.

Output Voltage and Frequency

When they are shipped, AF controllers are adjusted to provide a maximum output voltage and frequency equivalent to the input line voltage and frequency. The controllers can be adjusted to operate above line frequency, but a hazard of personal injury or equipment damage may exist when the motor is operated above base speed. Before adjusting the drive to operate above line frequency, make sure that the motor and the driven machinery can safely be operated at the resulting speed.

Features

Controller Features

Operator Control and Interface Requirements

Since there are many possible configurations and many ways of achieving a specific end result, it pays to consider the operator control and interface requirements carefully. A simplified and more economical drive package can often be achieved by selecting from standard product offerings rather than specifying a custom designed configuration.

Installation Compatibility

The successful application of an AC drive requires the assurance that the drive will be compatible with the environment in which it will be installed. In planning the installation, be sure to carefully consider the heat produced by the drive, the altitude and temperature limits and the need for clean cooling air. Other important considerations include acoustical noise, vibration, electromagnetic compatibility, power quality, controller input harmonic current and power distribution equipment requirements.

Auxiliary Equipment and Accessories

Adjustable drives are generally designed to have a motor directly connected to the controller output terminals with no other equipment connected in series or parallel. Motor starters, disconnect switches, surge absorbers, DV/DT suppression circuits, output chokes, output transformers and any other equipment under consideration for installation on the output of the controller should not be installed without first requesting Application Engineering assistance. Power factor correction capacitors must never, under any circumstances, be connected at the output of the controller. They would serve no useful purpose, and they may damage the controller.

Enclosure Definitions

- NEMA Type 1/IP21**—Enclosures are intended for indoor use primarily to provide a degree of protection against contact with enclosed equipment and provide a degree of protection against a limited amount of falling dirt in locations where unusual service conditions do not exist. Top or side openings in the NEMA Type 1/IP21 enclosure allow for the free exchange of inside and outside air while meeting the UL rod entry and rust resistance design tests.
- NEMA Type 12/IP54**—Enclosures are intended for indoor use primarily to provide a degree of protection against circulating dust, falling dirt and dripping noncorrosive liquids. To meet UL drip, dust and rust resistance tests, NEMA Type 12/IP54 enclosures have no openings to allow for the exchange of inside and outside air.
- Chassis IP00**—Similar to Protected Chassis IP20 except power terminals are protected by plastic shielding only. Primarily intended to be mounted inside a surrounding protective enclosure.
- NEMA Type 3R**—Similar in design to NEMA Type 12/IP54 except with more stringent design and test requirements.

Motor Protection

DV/DT and Peak Motor Voltage Solutions

Today's AFD products offer significantly improved performance, but at the potential cost of motor insulation stress. The fast switching time of the IGBT devices used in newer AFDs can cause a transmission line effect in the output power leads to the motor, leading to possibly damaging voltage levels. To meet this need,

NEMA has introduced a motor in MG1, Part 31, which provides an insulation system designed to maintain normal motor life in AFD applications. For existing motors, a motor protection scheme is required for longer cable runs. Eaton offers three standard solutions for existing systems.

- **MotoRx** This solution provides an energy recovery system which clamps the peak motor voltage to a safe level for standard motors. This option is used when the distance between a single motor and the drive is 600 ft or less.
- **Output Line Reactor** This option provides an output line reactor, reducing the DV/DT of the AFD output voltage and lessening the transmission line effect, to lower the peak voltage at the motor terminals.

SVX9000 Drives

2



Contents

Description	Page
SVX9000 Drives	
Standards and Certifications	V6-T2-49
Catalog Number Selection	V6-T2-49
Product Selection	V6-T2-50
Accessories	V6-T2-54
Options	V6-T2-55
Replacement Parts	V6-T2-61
Technical Data and Specifications	V6-T2-70
Dimensions	V6-T2-71
SVX9000 Enclosed Drives	V6-T2-87
SVX9000 VFD Pump Panels	V6-T2-111

SVX9000 Drives

Product Description

SVX9000 Series Adjustable Frequency Drives from Eaton's Electrical Sector are the next generation of drives specifically engineered for today's commercial and industrial applications. The power unit makes use of the most sophisticated semiconductor technology and a highly modular construction that can be flexibly adapted to the customer's needs.

The input and output configuration (I/O) is designed with modularity in mind. The I/O is comprised of option cards, each with its own input and output configuration. The control module is designed to accept a total of five of these cards. The cards contain not only normal analog and digital inputs but also fieldbus cards.

These drives continue the tradition of robust performance, and raise the bar on features and functionality, ensuring the best solution at the right price.

Features

- Robust design—proven 500,000 hours MTBF
- Integrated 3% line reactors standard on drives from FR4 through FR9
- EMI/RFI Filters H standard up to 200 hp I_H 480V, 100 hp I_H 230V
- Simplified operating menu allows for typical programming changes, while programming mode provides control of everything
- Quick Start Wizard built into the programming of the drive ensures a smooth start-up
- Keypad can display up to three monitored parameters simultaneously
- LOCAL/REMOTE operation from keypad
- Copy/paste function allows transfer of parameter settings from one drive to the next
- Standard NEMA Type 12/IP54 keypad on all drives
- The SVX can be flexibly adapted to a variety of needs using our pre-installed "Seven in One" precision application programs consisting of:
 - Basic
 - Standard
 - Local/remote
 - Multi step speed control
 - PID control
 - Multi-purpose control
 - Pump and fan control with auto change
- Additional I/O and communication cards provide plug and play functionality
- I/O connections with simple quick connection terminals
- Hand-held auxiliary 24V power supply allows programming/monitoring of control module without applying full power to the drive
- Control logic can be powered from an external auxiliary control panel, internal drive functions and fieldbus if necessary
- Brake chopper standard from: 1–30 hp/380–500V 3/4–15 hp/208–230V
- NEMA Type 1/IP21 and NEMA Type 12/IP54 enclosures available, Frame Sizes FR4–FR9
- Open chassis FR10 and greater
- Standard option board configuration includes an A9 I/O board and an A2 relay output board installed in slots A and B

Standards and Certifications

Product

- IEC 61800-2

EMC (At Default Settings)

- Immunity: Fulfills all EMC immunity requirements; Emissions: EN 61800-3, LEVEL H

Safety

- UL 508C
- CE



Catalog Number Selection

SVX9000 Adjustable Frequency Drives

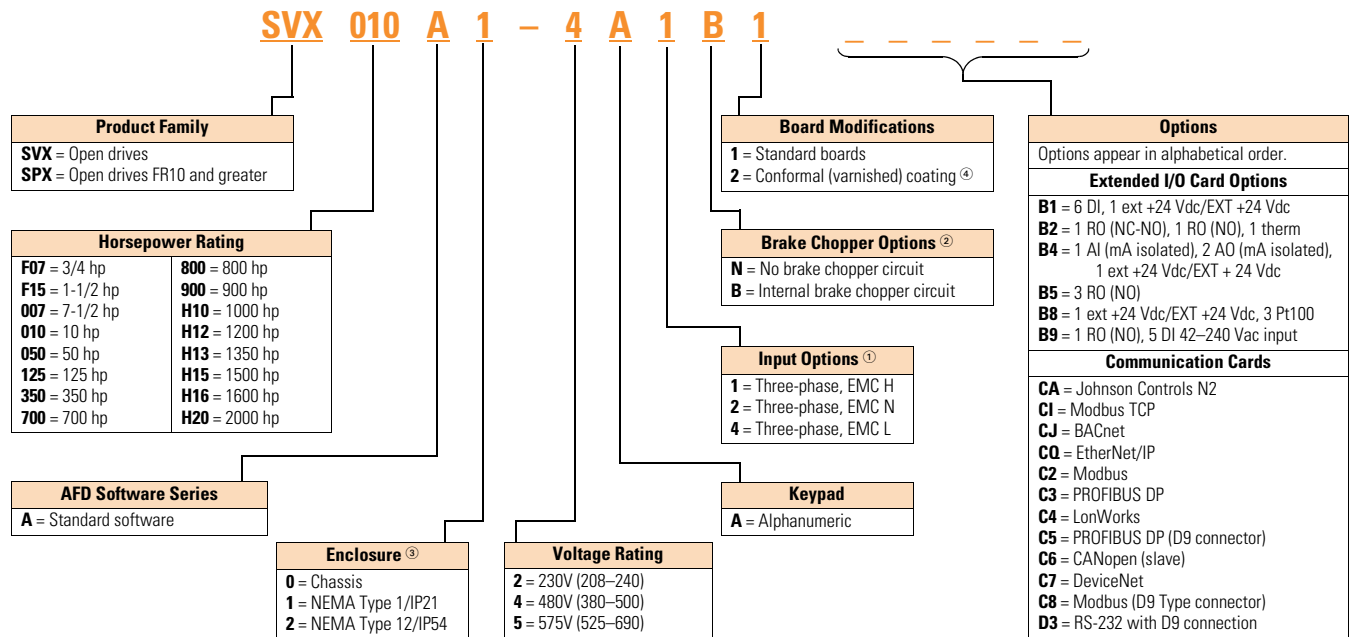

Notes

- ① All 230V drives and 480V drives up to 200 hp (IH) are only available with input option **1** (EMC Level H). 480V drives 250 hp (IH) or larger are available with input option **2** (EMC Level N). 480V drives are available with input option **4** (EMC Level L). 575V drives 200 hp (IH) or larger are only available with input option **2**. 575V drives up to 150 hp (IH) are only available with input option **4** (EMC Level L).
- ② 480V drives up to 30 hp (IH) are only available with brake chopper option **B**. 480V drives 40 hp (IH) or larger come standard with brake chopper option **N**. 230V drives up to 15 hp (IH) are only available with brake chopper option **B**. 230V drives 20 hp or larger come standard with brake chopper option **N**. All 575V drives come standard without brake chopper option (N). **N = No** brake chopper.
- ③ 480V drives 250 hp (I_H) and larger are available with enclosure style **0** (chassis); 690V drives 200 hp (I_H) and larger are available with enclosure style **0** (chassis).
- ④ Factory promise delivery. Consult sales office for availability.

Product Selection

230V SVX9000 Drives

2

SVX9000 Open Drives



208–240V, NEMA Type 1/IP21 Drives

Frame Size	hp (I _H)	Current (I _H)	hp (I _L)	Current (I _L)	Catalog Number
FR4	3/4	3.7	1	4.8	SVXF07A1-2A1B1
	1	4.8	1-1/2	6.6	SVX001A1-2A1B1
	1-1/2	6.6	2	7.8	SVXF15A1-2A1B1
	2	7.8	3	11	SVX002A1-2A1B1
	3	11	—	12.5	SVX003A1-2A1B1
FR5	—	12.5	5	17.5	SVX004A1-2A1B1
	5	17.5	7-1/2	25	SVX005A1-2A1B1
	7-1/2	25	10	31	SVX007A1-2A1B1
FR6	10	31	15	48	SVX010A1-2A1B1
	15	48	20	61	SVX015A1-2A1B1
FR7	20	61	25	75	SVX020A1-2A1N1
	25	75	30	88	SVX025A1-2A1N1
	30	88	40	114	SVX030A1-2A1N1
FR8	40	114	50	140	SVX040A1-2A1N1
	50	140	60	170	SVX050A1-2A1N1
	60	170	75	205	SVX060A1-2A1N1
FR9	75	205	100	261	SVX075A1-2A1N1
	100	261	125	300	SVX100A1-2A1N1

208–240V, NEMA Type 12/IP54 Drives

Frame Size	hp (I _H)	Current (I _H)	hp (I _L)	Current (I _L)	Catalog Number
FR4	3/4	3.7	1	4.8	SVXF07A2-2A1B1
	1	4.8	1-1/2	6.6	SVX001A2-2A1B1
	1-1/2	6.6	2	7.8	SVXF15A2-2A1B1
	2	7.8	3	11	SVX002A2-2A1B1
	3	11	—	12.5	SVX003A2-2A1B1
FR5	—	12.5	5	17.5	SVX004A2-2A1B1
	5	17.5	7-1/2	25	SVX005A2-2A1B1
	7-1/2	25	10	31	SVX007A2-2A1B1
FR6	10	31	15	48	SVX010A2-2A1B1
	15	48	20	61	SVX015A2-2A1B1
FR7	20	61	25	75	SVX020A2-2A1N1
	25	75	30	88	SVX025A2-2A1N1
	30	88	40	114	SVX030A2-2A1N1
FR8	40	114	50	140	SVX040A2-2A1N1
	50	140	60	170	SVX050A2-2A1N1
	60	170	75	205	SVX060A2-2A1N1
FR9	75	205	100	261	SVX075A2-2A1N1
	100	261	125	300	SVX100A2-2A1N1

480V SVX9000 Drives

SVX9000 Open Drives



380–500V, NEMA Type 1/IP21 Drives

Frame Size	hp (I _H)	Current (I _H)	hp (I _L)	Current (I _L)	Catalog Number
FR4	1	2.2	1-1/2	3.3	SVX001A1-4A1B1
	1-1/2	3.3	2	4.3	SVXF15A1-4A1B1
	2	4.3	3	5.6	SVX002A1-4A1B1
	3	5.6	5	7.6	SVX003A1-4A1B1
	5	7.6	—	9	SVX005A1-4A1B1
	—	9	7-1/2	12	SVX006A1-4A1B1
FR5	7-1/2	12	10	16	SVX007A1-4A1B1
	10	16	15	23	SVX010A1-4A1B1
	15	23	20	31	SVX015A1-4A1B1
FR6	20	31	25	38	SVX020A1-4A1B1
	25	38	30	46	SVX025A1-4A1B1
	30	46	40	61	SVX030A1-4A1B1
FR7	40	61	50	72	SVX040A1-4A1N1
	50	72	60	87	SVX050A1-4A1N1
	60	87	75	105	SVX060A1-4A1N1
FR8	75	105	100	140	SVX075A1-4A1N1
	100	140	125	170	SVX100A1-4A1N1
	125	170	150	205	SVX125A1-4A1N1
FR9	150	205	200	261	SVX150A1-4A1N1
	200	245	250	300	SVX200A1-4A1N1

380–500V, NEMA Type 12/IP54 Drives

Frame Size	hp (I _H)	Current (I _H)	hp (I _L)	Current (I _L)	Catalog Number
FR4	1	2.2	1-1/2	3.3	SVX001A2-4A1B1
	1-1/2	3.3	2	4.3	SVXF15A2-4A1B1
	2	4.3	3	5.6	SVX002A2-4A1B1
	3	5.6	5	7.6	SVX003A2-4A1B1
	5	7.6	—	9	SVX005A2-4A1B1
	—	9	7-1/2	12	SVX006A2-4A1B1
FR5	7-1/2	12	10	16	SVX007A2-4A1B1
	10	16	15	23	SVX010A2-4A1B1
	15	23	20	31	SVX015A2-4A1B1
FR6	20	31	25	38	SVX020A2-4A1B1
	25	38	30	46	SVX025A2-4A1B1
	30	46	40	61	SVX030A2-4A1B1
FR7	40	61	50	72	SVX040A2-4A1N1
	50	72	60	87	SVX050A2-4A1N1
	60	87	75	105	SVX060A2-4A1N1
FR8	75	105	100	140	SVX075A2-4A1N1
	100	140	125	170	SVX100A2-4A1N1
	125	170	150	205	SVX125A2-4A1N1
FR9	150	205	200	261	SVX150A2-4A1N1
	200	245	250	300	SVX200A2-4A1N1

SVX9000 Open Drives

380–500V, Open Chassis Drives

2



Frame Size	hp (I _H)	Current (I _H)	hp (I _L)	Current (I _L)	Catalog Number
FR10 ①	250	330	300	385	SPX250A0-4A2N1
	300	385	350	460	SPX300A0-4A2N1
	350	460	400	520	SPX350A0-4A2N1
FR11	400	520	500	590	SPX400A0-4A2N1
	500	590	—	650	SPX500A0-4A2N1
	—	650	600	730	SPX550A0-4A2N1
FR12	600	730	—	820	SPX600A0-4A2N1
	—	820	700	920	SPX650A0-4A2N1
	700	920	800	1030	SPX700A0-4A2N1
FR13	800	1030	900	1150	SPX800A0-4A2N1
	900	1150	1000	1300	SPX900A0-4A2N1
	1000	1300	1200	1450	SPXH10A0-4A2N1
FR14	1200	1600	1500	1770	SPXH12A0-4A2N1
	1600	1940	1800	2150	SPXH16A0-4A2N1
	1900	2300	2200	2700	SPXH19A0-4A2N1

575V SVX9000 Drives

525–690V, NEMA Type 1/IP21 Drives

Frame Size	hp (I _H)	Current (I _H)	hp (I _L)	Current (I _L)	Catalog Number
FR6	2	3.3	3	4.5	SVX002A1-5A4N1
	3	4.5	—	5.5	SVX003A1-5A4N1
	—	5.5	5	7.5	SVX004A1-5A4N1
	5	7.5	7-1/2	10	SVX005A1-5A4N1
	7-1/2	10	10	13.5	SVX007A1-5A4N1
	10	13.5	15	18	SVX010A1-5A4N1
	15	18	20	22	SVX015A1-5A4N1
	20	22	25	27	SVX020A1-5A4N1
FR7	25	27	30	34	SVX025A1-5A4N1
	30	34	40	41	SVX030A1-5A4N1
FR8	40	41	50	52	SVX040A1-5A4N1
	50	52	60	62	SVX050A1-5A4N1
FR9	60	62	75	80	SVX060A1-5A4N1
	75	80	100	100	SVX075A1-5A4N1
	100	100	125	125	SVX100A1-5A4N1
FR9	125	125	150	144	SVX125A1-5A4N1
	150	144	—	170	SVX150A1-5A4N1
	—	170	200	208	SVX175A1-5A4N1

Note

① FR10–FR14 includes 3% line reactor, but it is not integral to chassis.

SVX9000 Open Drives



525–690V, NEMA Type 12/IP54 Drives

Frame Size	hp (I _H)	Current (I _H)	hp (I _L)	Current (I _L)	Catalog Number
FR6	2	3.3	3	4.5	SVX002A2-5A4N1
	3	4.5	—	5.5	SVX003A2-5A4N1
	—	5.5	5	7.5	SVX004A2-5A4N1
	5	7.5	7-1/2	10	SVX005A2-5A4N1
	7-1/2	10	10	13.5	SVX007A2-5A4N1
	10	13.5	15	18	SVX010A2-5A4N1
	15	18	20	22	SVX015A2-5A4N1
	20	22	25	27	SVX020A2-5A4N1
FR7	25	27	30	34	SVX025A2-5A4N1
	30	34	40	41	SVX030A2-5A4N1
FR8	40	41	50	52	SVX040A2-5A4N1
	50	52	60	62	SVX050A2-5A4N1
	60	62	75	80	SVX060A2-5A4N1
FR9	75	80	100	100	SVX075A2-5A4N1
	100	100	125	125	SVX100A2-5A4N1
	125	125	150	144	SVX125A2-5A4N1
	150	144	—	170	SVX150A2-5A4N1
	—	170	200	208	SVX175A2-5A4N1

525–690V, Open Chassis Drives

Frame Size	hp (I _H)	Current (I _H)	hp (I _L)	Current (I _L)	Catalog Number
FR10	200	208	250	261	SPX200A0-5A2N1
	250	261	300	325	SPX250A0-5A2N1
	300	325	400	385	SPX300A0-5A2N1
FR11	400	385	450	460	SPX400A0-5A2N1
	450	460	500	502	SPX450A0-5A2N1
	500	502	—	590	SPX500A0-5A2N1
FR12	—	590	600	650	SPX550A0-5A2N1
	600	650	700	750	SPX600A0-5A2N1
	700	750	800	820	SPX700A0-5A2N1
FR13	800	820	900	920	SPX800A0-5A2N1
	900	920	1000	1030	SPX900A0-5A2N1
	1000	1030	1250	1180	SPXH10A0-5A2N1
FR14	1350	1300	1500	1500	SPXH13A0-5A2N1
	1500	1500	2000	1900	SPXH15A0-5A2N1
	2000	1900	2300	2250	SPXH20A0-5A2N1

Accessories

2

Demo Drive and Power Supply

Demo Drive and Power Supply

Description	Catalog Number
9000X demo drive	9000XDEMO

NEMA Type 12/IP54 Conversion Kit

The NEMA Type 12/IP54 kit option is used to convert a NEMA Type 1/IP21 to a NEMA Type 12/IP54 drive. The NEMA Type 12/IP54

kit consists of a metal drive shroud, fan kit for some frames, adaptor plate and plugs.

NEMA Type 12/IP54 Conversion Kit

Frame Size	Delivery Code	Approximate Dimensions in Inches (mm)			Approximate Weight Lb (kg)	Catalog Number
		Length	Width	Height		
FR4	W	13 (330)	7 (178)	4 (102)	4 (1.8)	OPTN12FR4
FR5		16 (406)	8 (203)	7 (178)	5 (2.3)	OPTN12FR5
FR6		21 (533)	10 (254)	5 (127)	7 (3.2)	OPTN12FR6

Flange Kits

Flange Kit NEMA Type 12/IP54

The flange kit is utilized when the power section is mounted through the back panel of an enclosure. Includes flange mount brackets and NEMA Type 12/IP54 fan components. Metal shroud not included.

Flange kits for NEMA Type 12/IP54 enclosure drive rating are determined by rating of drive.

Flange Kit NEMA Type 12/IP54— Frames 4, 5 and 6 ^①

Frame Size	Delivery Code	Catalog Number
FR4	W	OPTTHRFR4
FR5		OPTTHRFR5
FR6		OPTTHRFR6

Flange Kit NEMA Type 12/IP54— Frames 4–9

Frame Size	Delivery Code	Catalog Number
FR4	FP	OPTTHR4
FR5		OPTTHR5
FR6		OPTTHR6
FR7		OPTTHR7
FR8		OPTTHR8
FR9		OPTTHR9

Note

^① For installation of an SVX9000 NEMA Type 1/IP21 drive into a NEMA Type 12/IP54 oversized enclosure.

Options

9000X Series Option Board Kits

The 9000X Series drives can accommodate a wide selection of expander and adapter option boards to customize the drive for your application needs. The drive's control unit is designed to accept a total of five option boards.

The 9000X Series factory installed standard board configuration includes an A9 I/O board and an A2 relay output board, which are installed in slots A and B.

Option Boards

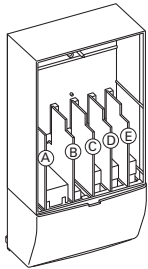

Option Board Kits

Option Kit Description ^①	Allowed Slot Locations ^②	Field Installed Catalog Number	Factory Installed Option Designator	SVX Ready Programs						
				Basic	Local/Remote	Standard	MSS	PID	Multi-P.	PFC
Standard I/O Cards										
6 DI, 1 DO, 2 AI, 1AO, 1 +10 Vdc ref, 2 ext +24 Vdc/EXT +24 Vdc	A	OPTA9	—	■	■	■	■	■	■	■
2 RO (NC-NO)	B	OPTA2	—	■	■	■	■	■	■	■
Extended I/O Cards										
2 RO, therm—SPX only	B	OPTA3	A3	—	■	■	■	■	■	■
Encoder low volt +5V/15V/24V—SPX only	C	OPTA4	A4	—	■	■	■	■	■	■
Encoder high volt +15V/24V—SPX only	C	OPTA5	A5	—	■	■	■	■	■	■
Double encoder—SPX only	C	OPTA7	A7	■	■	■	■	■	■	■
6 DI, 1 DO, 2 AI, 1 AO—SPX only	A	OPTA8	A8	—	■	■	■	■	■	■
3 DI (encoder 10–24V), out +15V/+24V, 2 DO (pulse+direction)—SPX only	C	OPTAE	AE	■	■	■	■	■	■	■
6 DI, 1 ext +24 Vdc/EXT +24 Vdc	B, C, D , E	OPTB1	B1	—	—	—	—	—	■	■
1 RO (NC-NO), 1 RO (NO), 1 therm	B, C, D , E	OPTB2	B2	—	—	—	—	—	■	■
1 AI (mA isolated), 2 AO (mA isolated), 1 ext +24 Vdc/EXT +24 Vdc	B, C, D , E	OPTB4	B4	■	■	■	■	■	■	■
3 RO (NO)	B, C, D , E	OPTB5	B5	—	—	—	—	—	■	■
1 ext +24 Vdc/EXT +24 Vdc, 3 Pt100	B, C, D , E	OPTB8	B8	—	—	—	—	—	—	—
1 RO (NO), 5 DI 42–240 Vac input	B, C, D , E	OPTB9	B9	—	—	—	—	—	■	■
Communication Cards										
Modbus ^③	D, E	OPTC2	C2	■	■	■	■	■	■	■
Johnson Controls N2 ^④	D, E	OPTC2	CA	—	—	—	—	—	—	—
Modbus TCP	D, E	OPTCI	CI	■	■	■	■	■	■	■
BACnet	D, E	OPTCJ	CJ	■	■	■	■	■	■	■
EtherNet/IP	D, E	OPTCQ	CQ	■	■	■	■	■	■	■
PROFIBUS DP	D, E	OPTC3	C3	■	■	■	■	■	■	■
LonWorks	D, E	OPTC4	C4	■	■	■	■	■	■	■
PROFIBUS DP (D9 connector)	D, E	OPTC5	C5	■	■	■	■	■	■	■
CANopen (slave) ^④	D, E	OPTC6	C6	■	■	■	■	■	■	■
DeviceNet	D, E	OPTC7	C7	■	■	■	■	■	■	■
Modbus (D9 type connector)	D, E	OPTC8	C8	■	■	■	■	■	■	■
Adapter—SPX only	D, E	OPTD1	D1	■	■	■	■	■	■	■
Adapter—SPX only	D, E	OPTD2	D2	■	■	■	■	■	■	■
RS-232 with D9 connection	D, E	OPTD3	D3	■	■	■	■	■	■	■

Notes

^① AI = Analog Input; AO = Analog Output, DI = Digital Input, DO = Digital Output, RO = Relay Output

^② Option card must be installed in one of the slots listed for that card. Slot indicated in bold is the preferred location.

^③ OPTC2 is a multi-protocol option card.

^④ SPX9000 drives only (FR10 and larger).

Modbus RTU Network Communications

The Modbus Network Card OPTC2 is used for connecting the 9000X Drive as a slave on a Modbus network. The interface is connected by a 9-pin DSUB connector (female) and the baud rate ranges from 300 to 19200 baud. Other communication parameters include an address range from 1 to 247; a parity of None, Odd or Even; and the stop bit is 1.

PROFIBUS Network Communications

The PROFIBUS Network Card OPTC3 is used for connecting the 9000X Drive as a slave on a PROFIBUS-DP network. The interface is connected by a 9-pin DSUB connector (female). The baud rates range from 9.6K baud to 12M baud, and the addresses range from 1 to 127.

LonWorks Network Communications

The LonWorks Network Card OPTC4 is used for connecting the 9000X Drive on a LonWorks network. This interface uses Standard Network Variable Types (SNVT) as data types. The channel connection is achieved using a FTT-10A Free Topology transceiver via a single twisted transfer cable. The communication speed with LonWorks is 78 kBits/s.

CANopen (Slave) Communications

The CANopen (Slave) Network Card OPTC6 is used for connecting the 9000X Drive to a host system. According to ISO11898 standard cables to be chosen for CAN bus should have a nominal impedance of 120 ohms, and specific line delay of nominal 5 nS/m. 120 ohms line termination resistors required for installation.

DeviceNet Network Communications

The DeviceNet Network Card OPTC7 is used for connecting the 9000X Drive on a DeviceNet Network. It includes a 5.08 mm pluggable connector. Transfer method is via CAN using a two-wire twisted shielded cable with two-wire bus power cable and drain. The baud rates used for communication include 125K baud, 250K baud and 500K baud.

Johnson Controls Metasys N2 Network Communications

The OPTC2 fieldbus board provides communication between the 9000X Drive and a Johnson Controls Metasys™ N2 network. With this connection, the drive can be controlled, monitored and programmed from the Metasys system. The N2 fieldbus is available as a factory installed option and as a field installable kit.

Modbus/TCP Network Communications

The Modbus/TCP Network Card OPTC1 is used for connecting the 9000X Drive to Ethernet networks utilizing Modbus protocol. It includes an RJ-45 pluggable connector. This interface provides a selection of standard and custom register values to communicate drive parameters. The board supports 10 Mbps and 100 Mbps communication speeds. The IP address of the board is configurable over Ethernet using a supplied software tool.

BACnet Network Communications

The BACnet Network Card OPTCJ is used for connecting the 9000X Drive to BACnet networks. It includes a 5.08 mm pluggable connector. Data transfer is Master-Slave/Token Passing (MS/TP) RS-485. This interface uses a collection of 30 Binary Value Objects (BVOs) and 35 Analog Value Objects (AVOs) to communicate drive parameters. The card supports 9.6, 19.2 and 38.4 Kbaud communication speeds and supports network addresses 1–127.

EtherNet/IP Network Communications

The EtherNet/IP Network Card OPTCK is used for connecting the 9000X Drive to Ethernet/Industrial Protocol networks. It includes an RJ-45 pluggable connector. The interface uses CIP objects to communicate drive parameters (CIP is “Common Industrial Protocol”, the same protocol used by DeviceNet). The board supports 10 Mbps and 100 Mbps communication speeds. The IP address of the board is configurable by Static, BOOTP and DHCP methods.

Control Panel Options**Factory Options**

Description	Factory Installed Option Code	Field Installed NEMA Type 1/IP21 Catalog Number
Local/Remote Keypad SVX9000 Control Panel —This option is standard on all drives and consists of an RS-232 connection, backlit alphanumeric LCD display with nine indicators for the RUN status and two indicators for the control source. The nine pushbuttons on the panel are used for panel programming and monitoring of all SVX9000 parameters. The panel is detachable and isolated from the input line potential. Include LOC/REM key to choose control location.	A	KEYPAD-LOC/REM
Keypad Remote Mounting Kit —This option is used to remote mount the SVX9000 keypad. The footprint is compatible to the SV9000 remote mount kit. Includes 10 ft cable, keypad holder and mounting hardware.	—	OPTRMT-KIT-9000X

Miscellaneous Options

Description	Catalog Number
9000XDrive —A PC-based tool for controlling and monitoring of the SVX9000. Features include: loading parameters that can be saved to a file or printed, setting references, starting and stopping the motor, monitoring signals in graphical or text form, and real-time display. To avoid damage to the drive or computer, SVDrivecable must be used.	9000XDRIVE
SVDrivecable —6 ft (1.8m) RS-232 cable (22 gauge) with a 7-pin connector on each end. Should be used in conjunction with the 9000XDrive option to avoid damage to the SVX9000 or computer. The same cable can be used for downloading specialized applications to the drive.	SVDRIVECABLE
External Dynamic Braking Resistors —Used with the dynamic braking chopper circuit to absorb motor regenerative energy for stopping the load and to dissipate the energy flowing back into the drive. Resistors are separated into standard duty and heavy-duty. Standard duty is defined as 20% duty or less with 100% braking torque, while heavy-duty is defined as 50% duty or less with 150% braking torque.	See Page V6-T2-58

2.5

Adjustable Frequency Drives

SVX9000 Drives

Open Drive Options

2

Brake Chopper Options

The brake chopper circuit option is used for applications that require dynamic braking. Dynamic braking resistors are not included with drive purchase. Consult the factory for additional dynamic braking resistor selections that are supplied separately. A list of common resistors are listed below and are complete indoor assemblies, include a pre-wired terminal block and a thermal switch, and are not UL Listed.

Duty Cycle

The duty cycle rating is based on a 60-second period. For example, the 20% duty cycle resistor can carry 100% current for 12 seconds out of every 60 seconds, while the 50% duty cycle resistor can carry 150% current for 30 seconds out of every 60 seconds.

Torque

If the braking torque required is less than 15%, dynamic braking is not required because the regenerated energy will be dissipated in the drive and motor losses.

Dynamic Brake Resistor—Catalog Number Selection

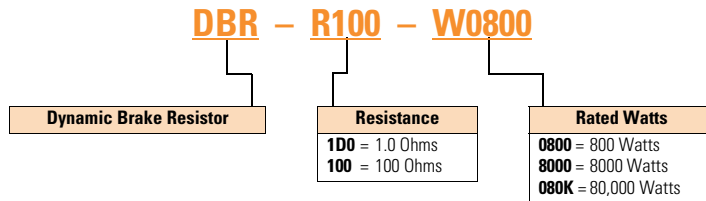

230V Brake Resistors

Drive hp (CT/l _H)	Minimum Ohms	20% Duty Cycle, 100% Torque		50% Duty Cycle, 150% Torque	
		Catalog Number	Dimensions (Inches)	Catalog Number	Dimensions (Inches)
0.75	30.0	DBR-R100-W0400	12W x 5D x 5H	DBR-R100-W0800	12W x 7D x 5H
1	30.0	DBR-R100-W0400	12W x 5D x 5H	DBR-R100-W0800	12W x 7D x 5H
1.5	30.0	DBR-R100-W0400	12W x 5D x 5H	DBR-R036-W1200	12W x 10D x 5H
2	30.0	DBR-R100-W0400	12W x 5D x 5H	DBR-R036-W1200	12W x 10D x 5H
3	30.0	DBR-R036-W0800	12W x 7D x 5H	DBR-R036-W2000	12W x 16D x 5H
4	30.0	DBR-R036-W0800	12W x 7D x 5H	DBR-R030-W2400	19W x 10D x 5H
5	30.0	DBR-R036-W0800	12W x 7D x 5H	DBR-R030-W2800	19W x 13D x 5H
7.5	20.0	DBR-R020-W1200	12W x 10D x 5H	DBR-R020-W4800	26.5W x 13D x 5H
10	10.0	DBR-R015-W1600	12W x 13D x 5H	DBR-R112-W6000	26.5W x 13D x 5H
15	10.0	DBR-R012-W2400	19W x 10D x 5H	DBR-R010-W9000	28W x 10D x 10H
20	3.3	DBR-R9D3-W3200	19W x 10D x 5H	DBR-R3D4-W012K	28W x 10D x 10H
25	3.3	DBR-R5D5-W4000	26.5W x 10D x 5H	DBR-R5D1-W015K	28W x 16D x 10H
30	3.3	DBR-R4D8-W4800	26.5W x 10D x 5H	DBR-R4D1-W020K	28W x 16D x 10H
40	1.4	DBR-R004-W6000	26.5W x 13D x 5H	DBR-R3D4-W025K	30W x 18D x 16H
50	1.4	DBR-R3D1-W7500	26.5W x 16D x 5H	DBR-R2D1-W030K	30W x 18D x 24H
60	1.4	DBR-R2D8-W9000	26.5W x 16D x 5H	DBR-R002-W036K	30W x 18D x 24H
75	1.4	DBR-R2D6-W012K	28W x 10D x 10H	DBR-R1D5-W045K	30W x 18D x 32H
100	1.4	DBR-R002-W015K	28W x 16D x 10H	DBR-R1D4-W060K	30W x 18D x 40H

480V Brake Resistors

Drive hp (CT/l _H)	Minimum Ohms	20% Duty Cycle, 100% Torque		50% Duty Cycle, 150% Torque	
		Catalog Number	Dimensions (Inches)	Catalog Number	Dimensions (Inches)
1	63.0	DBR-R100-W0400	12W x 5D x 5H	DBR-R100-W0800	12W x 7D x 5H
1.5	63.0	DBR-R100-W0400	12W x 5D x 5H	DBR-R100-W1200	12W x 10D x 5H
2	63.0	DBR-R100-W0400	12W x 5D x 5H	DBR-R100-W1200	12W x 10D x 5H
3	63.0	DBR-R100-W0800	12W x 7D x 5H	DBR-R100-W2000	12W x 16D x 5H
5	63.0	DBR-R100-W0800	12W x 7D x 5H	DBR-R100-W2800	19W x 13D x 5H
6	63.0	DBR-R100-W1200	12W x 10D x 5H	DBR-R070-W4000	19W x 16D x 5H
7.5	63.0	DBR-R100-W1200	12W x 10D x 5H	DBR-R063-W4800	26.5W x 13D x 5H
10	63.0	DBR-R063-W1600	12W x 13D x 5H	DBR-R063-W6000	26.5W x 16D x 5H
15	42.0	DBR-R042-W2400	19W x 10D x 5H	DBR-R042-W9000	28W x 10D x 10H
20	21.0	DBR-R030-W3200	19W x 13D x 5H	DBR-R023-W012K	28W x 13D x 10H
25	21.0	DBR-R030-W4000	19W x 16D x 5H	DBR-R021-W015K	28W x 13D x 10H
30	14.0	DBR-R020-W4800	26.5W x 13D x 5H	DBR-R014-W020K	30W x 18D x 24H
40	6.5	DBR-R112-W6000	26.5W x 13D x 5H	DBR-R007-W025K	30W x 18D x 16H
50	6.5	DBR-R013-W7500	26.5W x 16D x 5H	DBR-R8D5-W030K	30W x 18D x 24H
60	6.5	DBR-R010-W9000	28W x 10D x 10H	DBR-R7D3-W036K	30W x 18D x 24H
75	3.3	DBR-R009-W012K	28W x 13D x 10H	DBR-R3D3-W045K	30W x 18D x 32H
100	3.3	DBR-R5D1-W015K	28W x 16D x 10H	DBR-R004-W060K	30W x 18D x 40H
125	3.3	DBR-R4D1-W020K	28W x 16D x 10H	DBR-R004-W070K	30W x 18D x 48H
150	3.3	DBR-R3D4-W025K	30W x 18D x 16H	DBR-R3D5-W085K	30W x 18D x 56H
200	3.3	DBR-R3D3-W030K	30W x 18D x 24H	DBR-R3D3-W110K	30W x 18D x 72H
250	1.4	DBR-R2D5-W036K	30W x 18D x 24H	Ⓢ	—
300	1.4	DBR-R1D5-W045K	30W x 18D x 32H	Ⓢ	—
350	1.4	DBR-R1D4-W060K	30W x 18D x 40H	Ⓢ	—
400	0.9	DBR-R1D4-W060K	30W x 18D x 40H	Ⓢ	—
500	0.9	DBR-R0D9-W080K	30W x 18D x 48H	Ⓢ	—
550	0.9	DBR-R001-W085K	30W x 18D x 56H	Ⓢ	—

Note

Ⓢ Consult factory.

575V Brake Resistors

2

Drive hp (CT/l _H)	Minimum Ohms	20% Duty Cycle, 100% Torque		50% Duty Cycle, 150% Torque	
		Catalog Number	Dimensions (Inches)	Catalog Number	Dimensions (Inches)
2	100.0	DBR-R100-W0400	12W x 5D x 5H	DBR-R100-W1200	12W x 10D x 5H
3	100.0	DBR-R100-W0800	12W x 7D x 5H	DBR-R100-W2000	12W x 16D x 5H
4	100.0	DBR-R100-W0800	12W x 7D x 5H	DBR-R100-W2400	19W x 10D x 5H
5	100.0	DBR-R100-W0800	12W x 7D x 5H	DBR-R100-W2800	19W x 13D x 5H
7.5	100.0	DBR-R100-W1200	12W x 10D x 5H	DBR-R100-W4800	26.5W x 13D x 5H
10	30.0	DBR-R063-W1600	12W x 13D x 5H	DBR-R063-W6000	26.5W x 16D x 5H
15	30.0	DBR-R042-W2400	19W x 10D x 5H	DBR-R042-W9000	28W x 10D x 10H
20	30.0	DBR-R030-W3200	19W x 13D x 5H	DBR-R030-W012K	28W x 13D x 10H
25	30.0	DBR-R030-W4000	19W x 16D x 5H	DBR-R030-W015K	28W x 16D x 10H
30	18.0	DBR-R020-W4800	26.5W x 13D x 5H	DBR-R020-W020K	30W x 18D x 16H
40	18.0	DBR-R030-W6000	26.5W x 16D x 5H	DBR-R184-W025K	30W x 18D x 16H
50	9.0	DBR-R013-W7500	26.5W x 16D x 5H	DBR-R012-W030K	30W x 18D x 24H
60	9.0	DBR-R010-W9000	28W x 10D x 10H	DBR-R010-W036K	30W x 18D x 24H
75	9.0	DBR-R009-W012K	28W x 13D x 10H	DBR-R009-W045K	30W x 18D x 24H
100	7.0	DBR-R013-W015K	28W x 16D x 10H	DBR-R8D4-W060K	30W x 18D x 40H
125	7.0	DBR-R8D2-W020K	30W x 18D x 10H	DBR-R007-W070K	30W x 18D x 40H
150	7.0	DBR-R007-W025K	30W x 18D x 16H	DBR-R006-W085K	30W x 18D x 56H
175	7.0	DBR-R007-W030K	30W x 18D x 24H	DBR-R007-W100K	30W x 18D x 72H
200	2.5	DBR-R3D3-W030K	30W x 18D x 24H	DBR-R2D6-W110K	30W x 18D x 64H
250	2.5	DBR-R2D5-W036K	30W x 18D x 24H	DBR-R003-W140K	30W x 18D x 72H
300	2.5	DBR-R3D3-W045K	30W x 18D x 32H	①	—
400	1.7	DBR-R002-W060K	30W x 18D x 48H	①	—
450	1.7	DBR-R1D8-W070K	30W x 18D x 48H	①	—
500	1.7	DBR-R002-W080K	30W x 18D x 56H	①	—

Note

① Consult factory.

Replacement Parts

FR4 Spare Parts

Category	Description	Quantity/ Drive	230V Catalog Number	480V Catalog Number	575V Catalog Number
Control fan	NEMA Type 12 control fan ^①	1	PP01086	PP01086	—
Control module ^②	SVX control module	1	CSBS0000000000	CSBS0000000000	—
	Standard slot A I/O card	1	OPTA9	OPTA9	—
	Standard slot B I/O card	1	OPTA2	OPTA2	—
Converter	Power board ^③	1	VB00308-0004-2	VB00208-0003-5	—
		1	VB00308-0007-2	VB00208-0004-5	—
		1	VB00308-0008-2	VB00208-0005-5	—
		1	—	VB00208-0007-5	—
		1	—	VB00208-0009-5	—
		1	—	VB00410-0012-5-ARV	—
Keypad ^②	SVX/SPX keypad	1	KEYPAD-LOC/REM	KEYPAD-LOC/REM	—
Main fan ^②	DC fan (main)	1	PP01060	PP01060	—
Other	Mounting kit, fixing kit	1	FR00040	FR00040	—
	Mounting kit, fixing kit, N12 ^①	1	FR00079	FR00079	—
	Control cover, plastic, N1	1	FR00006	FR00006	—

FR5 Spare Parts

Category	Description	Quantity/ Drive	230V Catalog Number	480V Catalog Number	575V Catalog Number
Control fan	NEMA Type 12 control fan ^①	1	PP01088	PP01088	—
Control module ^②	SVX control module	1	CSBS0000000000	CSBS0000000000	—
	Standard slot A I/O card	1	OPTA9	OPTA9	—
	Standard slot B I/O card	1	OPTA2	OPTA2	—
Converter	Power board ^③	1	VB00313-0017-2	VB00213-0016-5	—
		1	VB00313-0025-2	VB00213-0022-5	—
		1	VB00313-0031-2	VB00213-0031-5	—
Keypad ^②	SVX/SPX keypad	1	KEYPAD-LOC/REM	KEYPAD-LOC/REM	—
Main fan ^②	DC fan (main)	1	PP01061	PP01061	—
Other	Mounting kit, fixing kit	1	FR00050	FR00050	—
	Mounting kit, fixing kit, N12 ^①	1	FR00081	FR00081	—
	Control cover, plastic, N1	1	FR05011	FR05011	—

Notes

- ^① Only for NEMA Type 12/IP54 Type drives.
- ^② Factory recommended spare parts.
- ^③ Select one part number based on the amperage rating of the drive. Please contact EatonCare at 877-ETN-CARE for assistance.

FR6 Spare Parts

2

Category	Description	Quantity/ Drive	230V Catalog Number	480V Catalog Number	575V Catalog Number
Control fan	NEMA Type 12 control fan ^①	1	PP01049	PP01049	—
Control module ^②	SVX control module	1	CSBS0000000000	CSBS0000000000	CSBS0000000000
	Standard slot A I/O card	1	OPTA9	OPTA9	OPTA9
	Standard slot B I/O card	1	OPTA2	OPTA2	OPTA2
Converter	Power board ^③	1	VB00316-0048-2	VB00416-0038-5	VB00404-0004-6
		1	VB00316-0061-2	VB00416-0045-5	VB00404-0005-6
		1	—	VB00416-0061-5	VB00404-0007-6
		1	—	—	VB00404-0010-6
		1	—	—	VB00404-0013-6
		1	—	—	VB00404-0018-6
		1	—	—	VB00404-0022-6
		1	—	—	VB00404-0027-6
		1	—	—	VB00404-0034-6
DC section	Bus capacitor	2	—	—	S00930
Keypad ^②	SVX/SPX keypad	1	KEYPAD-LOC/REM	KEYPAD-LOC/REM	KEYPAD-LOC/REM
Main fan ^②	DC fan (main)	1	PP01062	PP01062	—
Other	Mounting kit, fixing kit	1	FR00060	FR00060	FR00060
	Mounting kit, fixing kit, N12 ^①	1	FR00082	FR00082	FR00082
	Control cover, plastic, N1	1	FR06011	FR06011	FR06011

FR7 Spare Parts

Category	Description	Quantity/ Drive	230V Catalog Number	480V Catalog Number	575V Catalog Number
Control fan	NEMA Type 12 control fan ^①	1	PP01049	PP01049	PP01049
Control module ^②	SVX control module	1	CSBS0000000000	CSBS0000000000	CSBS0000000000
	Standard slot A I/O card	1	OPTA9	OPTA9	OPTA9
	Standard slot B I/O card	1	OPTA2	OPTA2	OPTA2
Converter	Power board ^③	1	VB00319-0075-2	VB00619-0072-5	VB00419-0041-6
		1	VB00319-0088-2	VB00619-0087-5	VB00419-0052-6
		1	VB00319-0114-2	VB00619-0105-5	—
DC section	Bus capacitor	2	—	—	PP01041
Keypad ^②	SVX/SPX keypad	1	KEYPAD-LOC/REM	KEYPAD-LOC/REM	KEYPAD-LOC/REM
Main fan ^②	DC fan (main)	1	PP01063	PP01063	PP01063
Other	Mounting kit, fixing kit	1	FR07071	FR07071	FR07071
	Mounting kit, fixing kit, N12 ^①	1	FR07072	FR07072	FR07072
	Control cover, plastic, N1	1	FR07011	FR07011	FR07011

Notes

^① Only for NEMA Type 12/IP54 Type drives.

^② Factory recommended spare parts.

^③ Select one part number based on the amperage rating of the drive. Please contact EatonCare at 877-ETN-CARE for assistance.

FR8 Spare Parts

Category	Description	Quantity/ Drive	230V Catalog Number	480V Catalog Number	575V Catalog Number
Control fan	NEMA Type 12 control fan ^①	1	CP01180	CP01180	CP01180
Control module ^②	SVX control module	1	CSBS0000000000	CSBS0000000000	CSBS0000000000
	Standard slot A I/O card	1	OPTA9	OPTA9	OPTA9
	Standard slot B I/O card	1	OPTA2	OPTA2	OPTA2
Converter	Power board ^③	1	VB00722-0140-2-ANV	VB00636-0140-4-ANV	VB00422-0062-5-ANV
		1	VB00722-0170-2-ANV	VB00636-0168-4-ANV	VB00422-0080-5-ANV
		1	VB00722-0205-2-ANV	VB00636-0205-4-ANV	VB00422-0100-5-ANV
	IGBT	2	PP01175	PP01175	PP01127
DC section	Bus capacitor	4	S00335	S00335	PP01041
Inverter	Diode	3	CP01268	CP01268	CP01373
	Rectifier board	1	VB00227	VB00227	VB00427
Keypad ^②	SVX/SPX keypad	1	KEYPAD-LOC/REM	KEYPAD-LOC/REM	KEYPAD-LOC/REM
Main AC fan	Fan AC	1	PP01123	PP01123	PP01123
	Fan fuse	2	PP20202	PP20202	PP20202
	Starting cap	1	S00734	S00734	S00734
	Fan driver board AC	1	VB00599	VB00799	VB00799
	Isolation transformer (fan)	1	S0000113	S0000113	S0000113
Main DC fan ^②	DC fan	1	PP00071	PP00071	PP00071
	DC power supply	1	S01016	S01016	S01016
Other	Front cover, N12 ^①	1	FR08079	FR08079	FR08079
	Conduit plate, N12	1	FR08082	FR08082	FR08082
	Front cover, N1	1	FR08106	FR08106	FR08106

Notes

^① Only for NEMA Type 12/IP54 Type drives.

^② Factory recommended spare parts.

^③ Select one part number based on the amperage rating of the drive. Please contact EatonCare at 877-ETN-CARE for assistance.

FR9 Spare Parts

2

Category	Description	Quantity/ Drive	230V Catalog Number	480V Catalog Number	575V Catalog Number
Control fan	50 mm fan	1	PP09041	PP09041	PP09041
	80 mm fan	1	PP01068	PP01068	PP01068
Control module ^①	SVX control module	1	CSBS0000000000	CSBS0000000000	CSBS0000000000
	Standard slot A I/O card	1	OPTA9	OPTA9	OPTA9
	Standard slot B I/O card	1	OPTA2	OPTA2	OPTA2
Converter	Power module ^②	1	FR09-0261-2-ANV	FR09-0261-4-ANV	FR09-0125-5-ANV
		1	FR09-0300-2-ANV	FR09-0300-4-ANV	FR09-0144-5-ANV
		1	—	—	FR09-0170-5-ANV
	Driver board	1	S00583	S00583	S00583
	Shunt board ^②	6	—	VB00535	VB00537
		6	—	VB00536	VB00542
		6	—	—	VB00543
DC section	Balancing resistor	3	PP00052	PP00052	PP00052
	Bus capacitor	8	S00335	S00335	PP01041
	DC busbars DC-	1	FR09043	FR09043	FR09043
	DC busbars DC+	1	FR09044	FR09044	FR09044
	DC busbars connection	1	FR09045	FR09045	FR09045
	DC busbars +/- insulator	1	FR09046	FR09046	FR09046
	DC busbars -/con insulator	1	FR09047	FR09047	FR09047
Inverter	Rectifier module	1	FR09826	FR09822	FR09823
	Diode	3	CP01268	CP01268	CP01268
	Rectifier board	1	—	VB00459	VB00460
Keypad ^①	SVX/SPX keypad	1	KEYPAD-LOC/REM	KEYPAD-LOC/REM	KEYPAD-LOC/REM
Main AC fan	Fan AC	1	PP01080	PP01080	PP01080
	Fan fuse	2	PP20202	PP20202	PP20202
	Starting cap	1	S00465	S00465	S00465
	Fan driver board AC	1	VB00899	VB00399	VB00299
	Isolation transformer (fan)	1	PP09056	PP09055	PP09055
Main DC fan ^①	DC fan	1	PP00072	PP00072	PP00072
	DC power supply	1	S01017	S01017	S01017
Other	Front cover power	1	FR09012	FR09012	FR09012
	Front cover connection	1	FR09013	FR09013	FR09013
	Front power conduit	1	FR09014	FR09014	FR09014

Notes

^① Factory recommended spare parts.

^② Select one part number based on the amperage rating of the drive. Please contact EatonCare at 877-ETN-CARE for assistance.

FR10 Spare Parts

Category	Description	Quantity/ Drive	230V Catalog Number	480V Catalog Number	575V Catalog Number
Control	Fiber board	1	—	S00451	S00451
	ASIC board	1	—	S00457	S00457
Control fan	ASIC fan	1	—	PP01096	PP01096
Control module ①	SVX control module	1	—	CPBS0000000000	CPBS0000000000
	Standard slot A I/O card	1	—	OPTA9	OPTA9
	Standard slot B I/O card	1	—	OPTA2	OPTA2
Converter	Power module ②	1	—	FR10-0385-4-ANV	FR10-0261-5-ANV
		1	—	FR10-0460-4-ANV	FR10-0325-5-ANV
		1	—	FR10-0520-4-ANV	FR10-0385-5-ANV
		1	—	—	FR10-0416-5-ANV
	Driver board	1	—	S00450	S00450
	Driver adapter board	1	—	VB00330	VB00330
	Shunt board ②	6	—	VB00497	VB00510
		6	—	VB00498	VB00511
		6	—	VB00537	VB00545
	Covers	Top cover	1	—	FR10340
Side cover		2	—	FR10341	FR10341
DC section	Balancing resistor	2	—	PP13027	PP13028
	DC busbars kit (right)	1	—	S0000005	S0000005
	Bus capacitor	12	—	S00335	S00336
Inverter	Rectifier module	1	—	FR10823	FR10823
	Charging resistor	1	—	PP00066	PP00066
	Diode	3	—	PP01177	PP01177
	Rectifier board	1	—	S00591	S00592
Keypad ①	SVX/SPX keypad	1	—	KEYPAD-LOC/REM	KEYPAD-LOC/REM
Main AC fan	Fan assembly (left)	1	—	FR10846	FR10846
	Fan assembly (right)	1	—	FR10847	FR10847
	Fan AC	2	—	PP01080	PP01080
	Fan fuse	4	—	PP20202	PP20202
	Starting cap	2	—	S00528	S00528
	Fan driver board AC	2	—	VB00299	VB00299
	Isolation transformer (left)	1	—	FR10844	FR10844
	Isolation transformer (right)	1	—	FR10845	FR10845
Main DC fan ①	DC fan	2	—	PP00072	PP00072
	DC power supply	2	—	S01017	S01017

Notes

① Factory recommended spare parts.

② Select one part number based on the amperage rating of the drive. Please contact EatonCare at 877-ETN-CARE for assistance.

FR11 Spare Parts

2

Category	Description	Quantity/ Drive	230V Catalog Number	480V Catalog Number	575V Catalog Number
Control	Fiber board	1	—	S00451	S00451
	ASIC board	1	—	S00457	S00457
Control fan	ASIC fan	1	—	PP01096	PP01096
Control module ^①	SVX control module	1	—	CPBS0000000000	CPBS0000000000
	Standard slot A I/O card	1	—	OPTA9	OPTA9
	Standard slot B I/O card	1	—	OPTA2	OPTA2
Converter	Power module ^②	1	—	FR11-0590-4-ANV	FR11-0460-5-ANV
		1	—	FR11-0650-4-ANV	FR11-0502-5-ANV
		1	—	FR11-0730-4-ANV	FR11-0590-5-ANV
	Driver board	1	—	S00452	S00452
	Driver adapter board	1	—	VB00330	VB00330
	Shunt board ^②	9	—	VB00513	VB00512
		9	—	VB00514	VB00546
		9	—	VB00538	VB00547
	Covers	Top cover	1	—	FR11345
DC section	Balancing resistor	3	—	PP13027	PP13027
	DC busbars kit (right)	3	—	S0000005	S0000005
	Bus capacitor	18	—	S00335	S00335
Inverter	Rectifier module	1	—	FR10823	FR10823
	Diode	3	—	PP01177	PP01177
	Rectifier board	1	—	S00591	S00591
Keypad ^①	SVX/SPX keypad	1	—	KEYPAD-LOC/REM	KEYPAD-LOC/REM
Main AC fan	Fan assembly (right)	3	—	FR10847	FR10847
	Fan AC	3	—	PP01080	PP01080
	Fan fuse	4	—	PP20202	PP20202
	Starting cap	3	—	S00530	S00530
	Fan driver board AC	3	—	VB00299	VB00299
	Isolation transformer (right)	3	—	FR10845	FR10845
Main DC fan ^①	DC fan	2	—	PP00072	PP00072
	DC power supply	2	—	S01017	S01017

Notes

^① Factory recommended spare parts.

^② Select one part number based on the amperage rating of the drive. Please contact EatonCare at 877-ETN-CARE for assistance.

FR12 Spare Parts

Category	Description	Quantity/ Drive	230V Catalog Number	480V Catalog Number	575V Catalog Number
Control	Fiber board	2	—	S00451	S00451
	ASIC board	2	—	S00457	S00457
	Star coupler	1	—	S00593	S00593
Control fan	ASIC fan	2	—	PP01096	PP01096
Control module ①	SVX control module	1	—	CPBS0000000000	CPBS0000000000
	Standard slot A I/O card	1	—	OPTA9	OPTA9
	Standard slot B I/O card	1	—	OPTA2	OPTA2
Converter	Power module ②	1	—	FR12-0820-4-ANV	FR12-0650-5-ANV
		1	—	FR12-0920-4-ANV	FR12-0750-5-ANV
		1	—	FR12-1030-4-ANV	FR12-0820-5-ANV
	Driver board	2	—	S00450	S00450
	Driver adapter board	2	—	VB00330	VB00330
	Shunt board	12	—	VB00498	VB00511
Covers	Top cover	2	—	FR10340	FR10340
	Side cover	4	—	FR10341	FR10341
DC section	Balancing resistor	4	—	PP13027	PP13027
	DC busbars kit (right)	2	—	S0000005	S0000005
	Bus capacitor	24	—	S00335	S00336
Inverter	Rectifier module	2	—	FR10823	FR10823
	Diode	3	—	PP01177	PP01177
	Rectifier board	2	—	S00591	S00591
Keypad ①	SVX/SPX keypad	1	—	KEYPAD-LOC/REM	KEYPAD-LOC/REM
Main AC fan	Fan assembly (left)	2	—	FR10846	FR10846
	Fan assembly (right)	2	—	FR10847	FR10847
	Fan AC	4	—	PP01080	PP01080
	Fan fuse	8	—	PP20202	PP20202
	Starting cap	4	—	S00528	S00528
	Fan driver board AC	4	—	VB00299	VB00299
	Isolation transformer (left)	2	—	FR10844	FR10844
	Isolation transformer (right)	2	—	FR10845	FR10845
Main DC fan ①	DC fan	4	—	PP00072	PP00072
	DC power supply	4	—	S01017	S01017

Notes

① Factory recommended spare parts.

② Select one part number based on the amperage rating of the drive. Please contact EatonCare at 877-ETN-CARE for assistance.

FR13 Spare Parts

2

Category	Description	Quantity/ Drive	230V Catalog Number	480V Catalog Number	575V Catalog Number
Control	ASIC board	1	—	S00457	S00457
	ASIC assembly	1	—	60S01030	60S01030
Control fan	ASIC fan	1	—	PP01096	PP01096
Control module ①	SVX control module	1	—	CPBS0000000000	CPBS0000000000
	Standard slot A I/O card	1	—	OPTA9	OPTA9
	Standard slot B I/O card	1	—	OPTA2	OPTA2
Converter	Power module ②	3	—	FI13-1150-4-ANV	FR13-1030-5-ANV
		3	—	FI13-1300-4-ANV	FR13-1180-5-ANV
		3	—	FI13-1450-4-ANV	FR13-920-5-ANV
	Driver board	3	—	S00454	S00454
	Driver adapter board	2	—	VB00330	VB00330
	Shunt board ②	18	—	VB00505	VB00516
		18	—	VB00514	VB00517
		18	—	VB00541	VB00547
Covers	Top cover	3	—	FI10001	FI10001
	Side cover	3	—	FI10003	FI10003
DC section	Balancing resistor	6	—	PP13034	PP13034
	Bus capacitor	36	—	S00335	S00336
	DC busbars kit	3	—	FI13329	FI13329
Inverter	Rectifier module	2	—	FR10823	FR10823
	Diode	3	—	PP01177	PP01177
	Rectifier board	2	—	S00591	S00591
Keypad ①	SVX/SPX keypad	1	—	KEYPAD-LOC/REM	KEYPAD-LOC/REM
Main AC fan	Fan assembly (left)	3	—	FI13301	FI13301
	Fan AC	3	—	PP01080	PP01080
	Fan fuse	6	—	PP20202	PP20202
	Starting cap	3	—	S00520	S00520
	Fan driver board AC	3	—	VB00299	VB00299
	Isolation transformer	3	—	PP10057	PP10057
Main DC fan ①	DC fan	4	—	PP00072	PP00072
	DC power supply	4	—	S01017	S01017

Notes

① Factory recommended spare parts.

② Select one part number based on the amperage rating of the drive. Please contact EatonCare at 877-ETN-CARE for assistance.

FR14 Spare Parts

Category	Description	Quantity/ Drive	230V Catalog Number	480V Catalog Number	575V Catalog Number
Control	ASIC board	2	—	S00457	S00457
	Star coupler	1	—	S00593	S00593
	ASIC assembly	2	—	60S01030	60S01030
	Star coupler kit	1	—	FR10860	FR10860
Control fan	ASIC fan	2	—	PP01096	PP01096
Control module ^①	SVX control module	1	—	CPBS0000000000	CPBS0000000000
	Standard slot A I/O card	1	—	OPTA9	OPTA9
	Standard slot B I/O card	1	—	OPTA2	OPTA2
Converter	Power module ^②	1	—	FR14-1770-4-ANV	FR14-1500-5-ANV
		1	—	FR14-2150-4-ANV	FR14-1900-5-ANV
		1	—	FR14-2700-4-ANV	FR14-2250-5-ANV
	Driver board	6	—	S00454	S00454
	Driver adapter board	2	—	VB00330	VB00330
	Shunt board ^②	36	—	VB00541	VB00516
		36	—	—	VB00517
Covers	Top cover	6	—	FI10001	FI10001
	Side cover	6	—	FI10003	FI10003
DC section	Balancing resistor	6	—	PP13034	PP13034
	Bus capacitor	72	—	S00335	S00336
	DC busbars kit	6	—	FI13329	FI13329
Inverter	Rectifier module	2	—	FR10823	FR10823
	Diode	3	—	PP01177	PP01177
	Rectifier board	2	—	S00591	S00591
Keypad ^①	SVX/SPX keypad	1	—	KEYPAD-LOC/REM	KEYPAD-LOC/REM
Main AC fan	Fan assembly (left)	6	—	FI13301	FI13301
	Fan AC	6	—	PP01080	PP01080
	Fan fuse	12	—	PP20202	PP20202
	Starting cap	6	—	S00520	S00520
	Fan driver board AC	6	—	VB00299	VB00299
	Isolation transformer	6	—	PP10057	PP10057
Main DC fan ^①	DC fan	6	—	PP00072	PP00072
	DC power supply	6	—	S01017	S01017

Notes

^① Factory recommended spare parts.

^② Select one part number based on the amperage rating of the drive. Please contact EatonCare at 877-ETN-CARE for assistance.

Technical Data and Specifications

SVX9000 Drives

2

Description	Specification
Input Ratings	
Input voltage (V_{in})	+10%/-15%
Input frequency (f_{in})	50/60 Hz (variation up to 45-66 Hz)
Connection to power	Once per minute or less (typical operation)
High withstand rating	100 kAIC
Output Ratings	
Output voltage	0 to V_{in}
Continuous output current	I_H rated 100% at 122°F (50°C), FR9 and below I_L rated 100% at 104°F (40°C), FR9 and below I_H/I_L 100% at 104°F (40°C), FR10 and above
Overload current (I_H/I_L)	150% I_H , 110% I_L for 1 min.
Output frequency	0 to 320 Hz
Frequency resolution	0.01 Hz
Initial output current (I_H)	250% for 2 seconds
Control Characteristics	
Control method	Frequency control (V/f) Open loop: Sensorless vector control Closed loop: SPX9000 drives only
Switching frequency Frame 4-6 Frame 7-12	Adjustable with parameter 2.6.9 1-16 kHz; default 10 kHz 1-10 kHz; default 3.6 kHz
Frequency reference	Analog input: Resolution 0.1% (10-bit), accuracy $\pm 1\%$ V/Hz Panel reference: Resolution 0.01 Hz
Field weakening point	30-320 Hz
Acceleration time	0-3000 sec.
Deceleration time	0-3000 sec.
Braking torque	DC brake: 30% x T_n (without brake option)
Ambient Conditions	
Ambient operating temperature	14°F (-10°C), no frost to 122°F (50°C) I_H (FR4-FR9) 14°F (-10°C), no frost to 104°F (40°C) I_H (FR10 and up) 14°F (-10°C), no frost to 104°F (40°C) I_L (all frames)
Storage temperature	-40° to 158°F (-40° to 70°C)
Relative humidity	0 to 95% RH, noncondensing, non-corrosive, no dripping water
Air quality	Chemical vapors: IEC 721-3-3, unit in operation, class 3C2; Mechanical particles: IEC 721-3-3, unit in operation, class 3S2
Altitude	100% load capacity (no derating) up to 3280 ft (1000m); 1% derating for each 328 ft (100m) above 3280 ft (1000m); max. 9842 ft (3000m)
Vibration	EN 50178, EN 60068-2-6; 5 to 50 Hz, displacement amplitude 1 mm (peak) at 3 to 15.8 Hz, max. acceleration amplitude 1G at 15.8 to 150 Hz
Shock	EN 50178, EN 60068-2-27 UPS Drop test (for applicable UPS weights) Storage and shipping: max. 15G, 11 ms (in package)
Enclosure class	NEMA 1/IP21 or NEMA 12/IP54, open chassis/IP20

Description	Specification
Control Connections	
Analog input voltage	0 to 10V, $R = 200$ kohms (-10 to 10V joystick control) resolution 0.1%; accuracy $\pm 1\%$
Analog input current	0(4) to 20 mA; $R_i = 250$ ohms differential
Digital inputs (6)	Positive or negative logic; 18 to 30 Vdc
Auxiliary voltage	+24V $\pm 15\%$, max. 250 mA
Output reference voltage	+10V +3%, max. load 10 mA
Analog output	0(4) to 20 mA; R_i max. 500 ohms; resolution 10 bit; accuracy $\pm 2\%$
Digital outputs	Open collector output, 50 mA/48V
Relay outputs	Two programmable Form C relay outputs switching capacity: 24 Vdc/8A, 250 Vac/8A, 125 Vdc/0.4A
Protections	
Overcurrent protection	Trip limit 4.0 x I_H instantaneously
Overvoltage protection	Yes
Undervoltage protection	Yes
Earth fault protection	In case of earth fault in motor or motor cable, only the frequency converter is protected
Input phase supervision	Trips if any of the input phases are missing
Motor phase supervision	Trips if any of the output phases are missing
Overtemperature protection	Yes
Motor overload protection	Yes
Motor stall protection	Yes
Motor underload protection	Yes
Short-circuit protection	Yes (+24V and +10V reference voltages)

Standard I/O Specifications

Description	Specification
Six-digital input programmable	24V: "0" $\leq 10V$, "1" $\geq 18V$, $R_i > 5$ kohms
Two-analog input configurable w/jumpers	Voltage: 0- $\pm 10V$, $R_i > 200$ kohms Current: 0 (4)-20 mA, $R_i = 250$ ohms
Two-digital output programmable	Form C relays 250 Vac 30 Vdc 2 amp resistive
One-analog output programmable configurable w/jumper	0-20 mA, R_i max. 500 ohms 10 bits $\pm 2\%$
One digital output programmable	Open collector 48 Vdc 50 mA

Dimensions

Approximate Dimensions in Inches (mm)

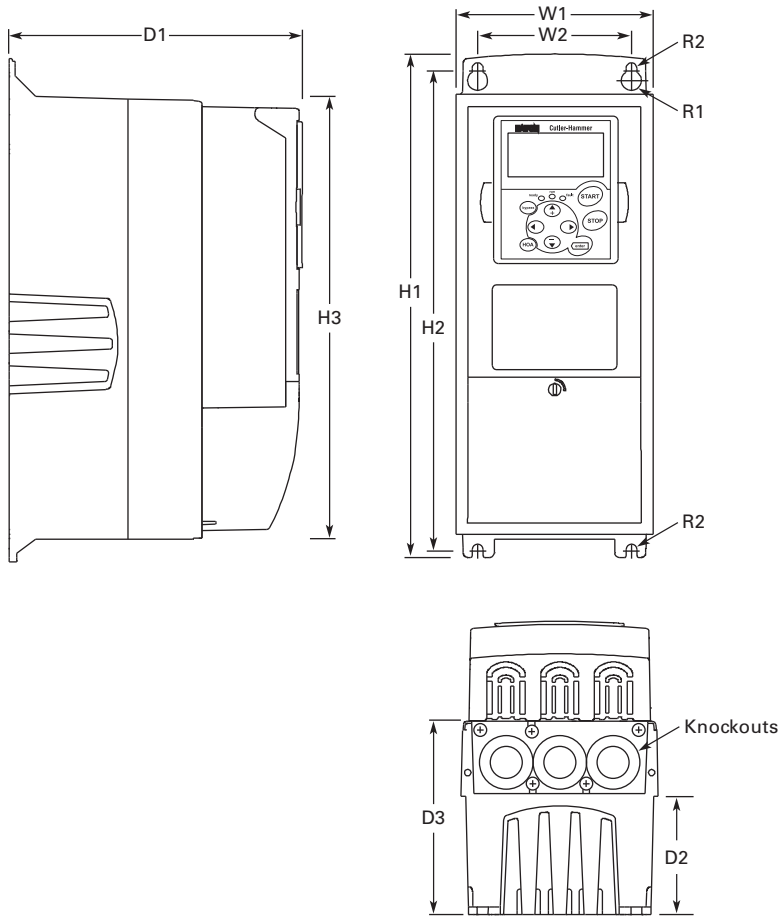
9000X Open Drives**NEMA Type 1/IP21 and NEMA Type 12/IP54, FR4, FR5 and FR6**

Voltage	hp (I _H)	H1	H2	H3	D1	D2	D3	W1	W2	R1 Dia.	R2 Dia.	Weight Lbs (kg)	Knockouts at Inches (mm) N1 (O.D.)
FR4													
230V	3/4–3	12.9	12.3	11.5	7.5	3.0	4.9	5.0	3.9	0.5 (13)	0.3 (7)	11.0 (5)	3 @ 1.1 (28)
480V	1–5	(327)	(313)	(292)	(190)	(77)	(126)	(128)	(100)				
FR5													
230V	5–7-1/2	16.5	16.0	15.3	8.4	3.9	5.8	5.6	3.9	0.5 (13)	0.3 (7)	17.9 (8)	2 @ 1.5 (37)
480V	7-1/2–15	(419)	(406)	(389)	(214)	(100)	(148)	(143)	(100)				1 @ 1.1 (28)
FR6													
230V	10–15	22.0	21.3	20.4	9.3	4.2	6.5	7.6	5.8	0.6 (15.5)	0.4 (9)	40.8 (19)	3 @ 1.5 (37)
480V	20–30	(558)	(541)	(519)	(237)	(105)	(165)	(195)	(148)				
575V	2–25												

2.5

Adjustable Frequency Drives

SVX9000 Drives

Approximate Dimensions in Inches (mm)

NEMA Type 1/IP21 and NEMA Type 12/IP54 with Flange Kit, FR4, FR5 and FR6

2

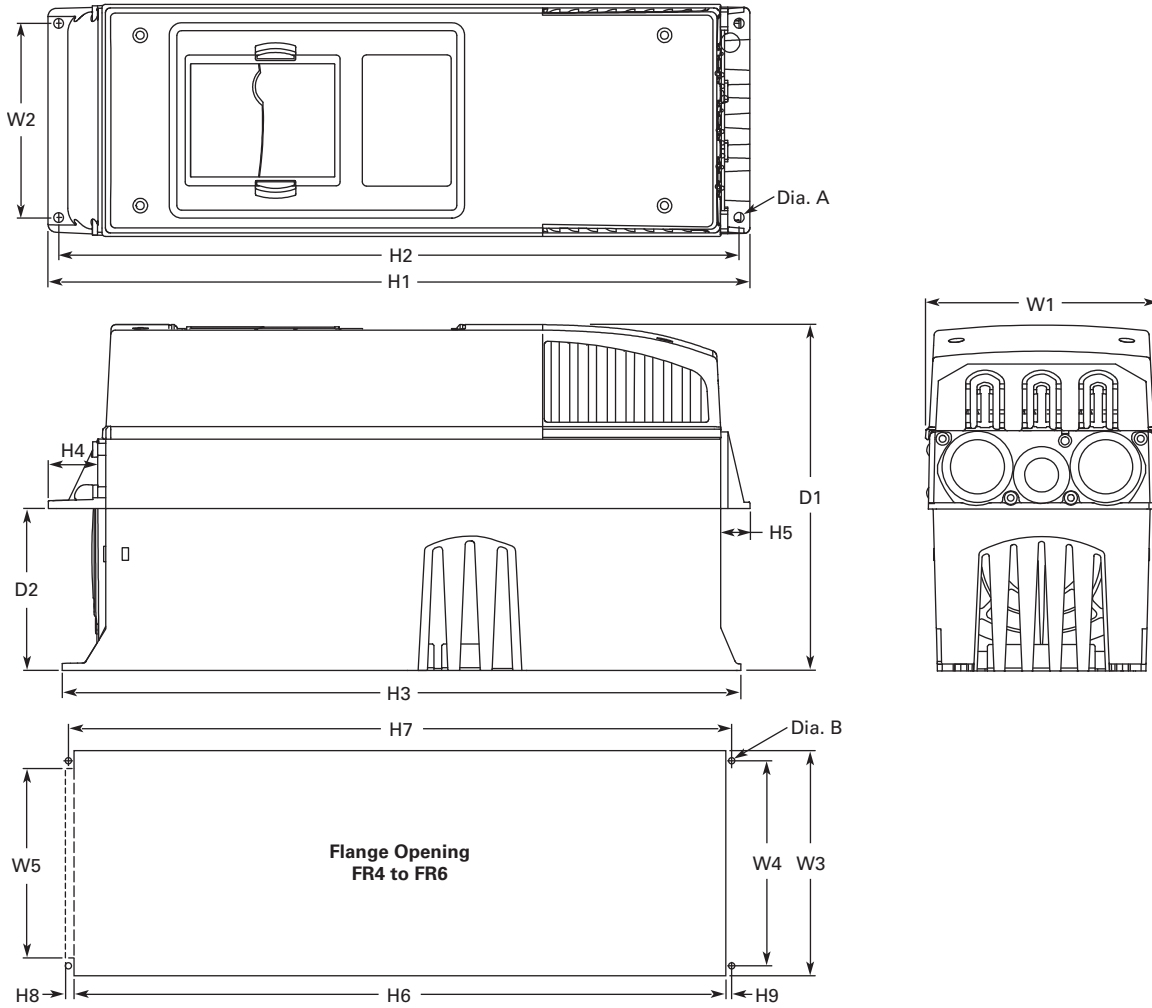

FR4, FR5 and FR6 with Flange Kit

W1	W2	H1	H2	H3	H4	H5	D1	D2	Dia. A
FR4									
5.0 (128)	4.5 (113)	13.3 (337)	12.8 (325)	12.9 (327)	1.2 (30)	0.9 (22)	7.5 (190)	3.0 (77)	0.3 (7)
FR5									
5.6 (143)	4.7 (120)	17.0 (434)	16.5 (420)	16.5 (419)	1.4 (36)	0.7 (18)	8.4 (214)	3.9 (100)	0.3 (7)
FR6									
7.7 (195)	6.7 (170)	22.0 (560)	21.6 (549)	22.0 (558)	1.2 (30)	0.8 (20)	9.3 (237)	4.2 (106)	0.3 (7)

Flange Opening, FR4 to FR6

W3	W4	W5	H6	H7	H8	H9	Dia. B
FR4							
4.8 (123)	4.5 (113)	—	12.4 (315)	12.8 (325)	—	0.2 (5)	0.3 (7)
FR5							
5.3 (135)	4.7 (120)	—	16.2 (410)	16.5 (420)	—	0.2 (5)	0.3 (7)
FR6							
7.3 (185)	6.7 (170)	6.2 (157)	21.2 (539)	21.6 (549)	0.3 (7)	0.2 (5)	0.3 (7)

Approximate Dimensions in Inches (mm)

NEMA Type 1/IP21 and NEMA Type 12/IP54, FR7

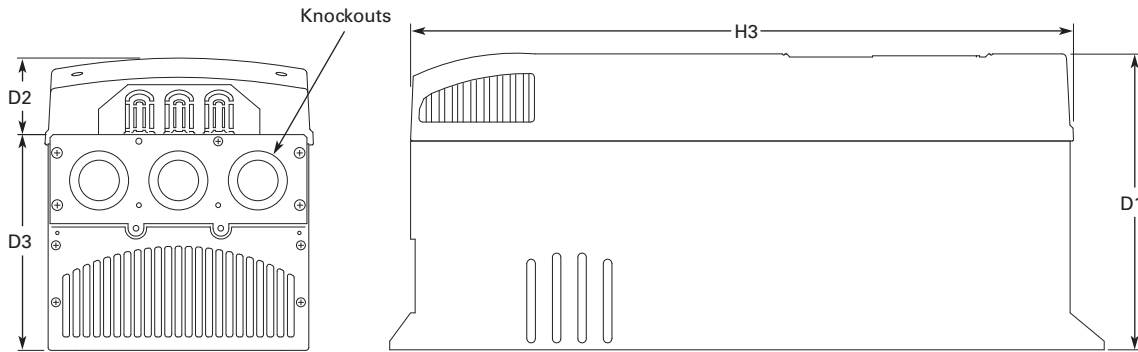
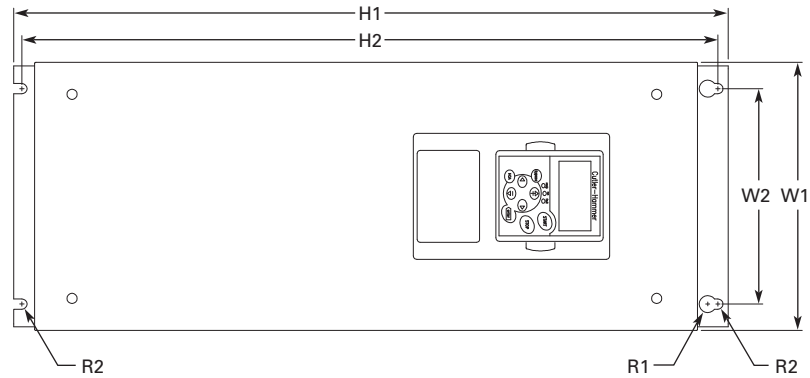

Voltage	hp (I _H)	H1	H2	H3	D1	D2	D3	W1	W2	R1 Dia.	R2 Dia.	Weight Lbs (kg)	Knockouts at Inches (mm) N1 (O.D.)
230V	20–30	24.8 (630)	24.2 (614)	23.2 (590)	10.1 (257)	3.0 (77)	7.3 (184)	9.3 (237)	7.5 (190)	0.7 (18)	0.4 (9)	77.2 (35)	3 at 1.5 (37)
480V	40–60												
575V	30–40												

2.5

Adjustable Frequency Drives

SVX9000 Drives

Approximate Dimensions in Inches (mm)

NEMA Type 1/IP21 and NEMA Type 12/IP54, FR8

2

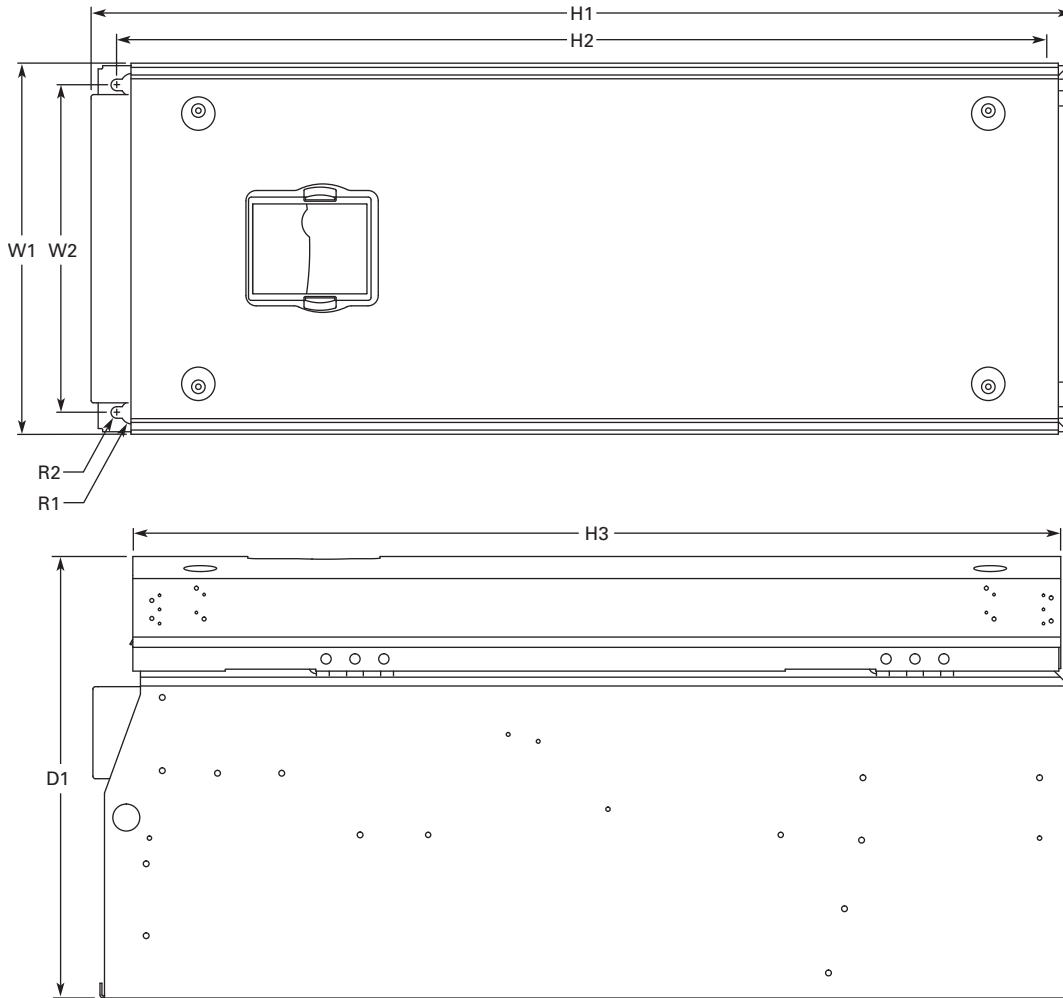

Voltage	hp (I _H)	D1	H1	H2	H3	W1	W2	R1 Dia.	R2 Dia.	Weight Lbs (kg)
230V	40–60	13.5 (344)	30.1 (764)	28.8 (732)	28.4 (721)	11.5 (291)	10 (255)	0.7 (18)	0.4 (9)	127 (58)
480V	75–125									
575V	50–75									

Approximate Dimensions in Inches (mm)

NEMA Type 1/IP21 and NEMA Type 12/IP54, with Flange Kit, FR7 and FR8

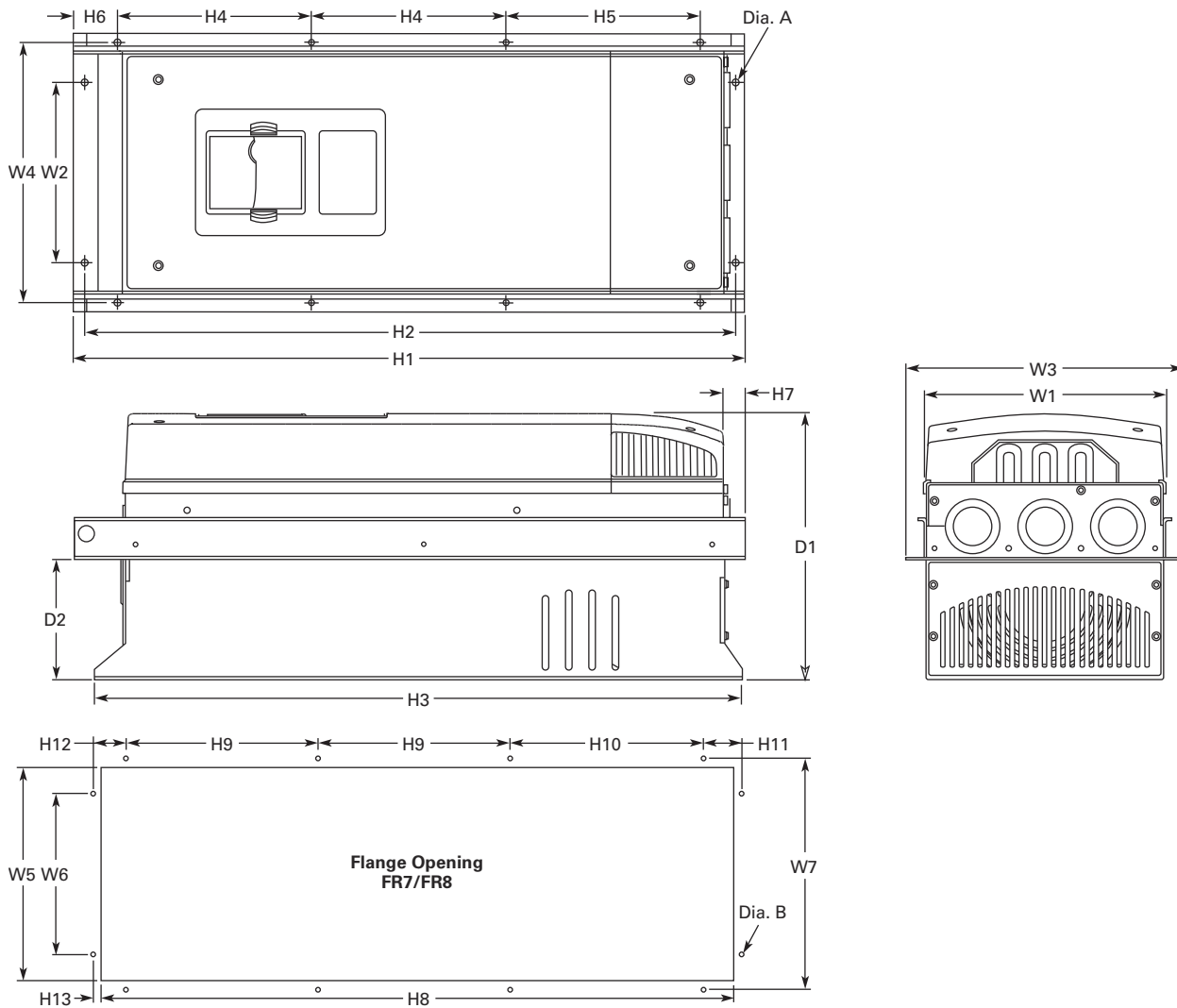

W1	W2	W3	W4	H1	H2	H3	H4	H5	H6	H7	D1	D2	Dia. A
FR7													
9.3 (237)	6.8 (175)	10.6 (270)	10.0 (253)	24.9 (652)	24.8 (632)	24.8 (630)	7.4 (189)	7.4 (189)	0.9 (23)	0.8 (20)	10.1 (257)	4.6 (117)	0.3 (6)
FR8													
11.2 (285)	—	14.0 (355)	13.0 (330)	32.8 (832)	—	29.3 (745)	10.2 (258)	10.4 (265)	1.7 (43)	2.2 (57)	13.5 (344)	4.3 (110)	0.4 (9)

Flange Opening, FR7 and FR8

W5	W6	W7	H8	H9	H10	H11	H12	H13	Dia. B
FR7									
9.2 (233)	6.9 (175)	10.0 (253)	24.4 (619)	7.4 (189)	7.4 (189)	1.4 (35)	1.3 (32)	1.0 (25)	0.3 (6)
FR8									
11.9 (301)	—	13.0 (330)	31.9 (810)	10.2 (258)	10.4 (265)	—	—	1.3 (33)	0.4 (9)

2.5

Adjustable Frequency Drives

SVX9000 Drives

Approximate Dimensions in Inches (mm)

NEMA Type 1/IP21 and NEMA Type 12/IP54 FR9

2

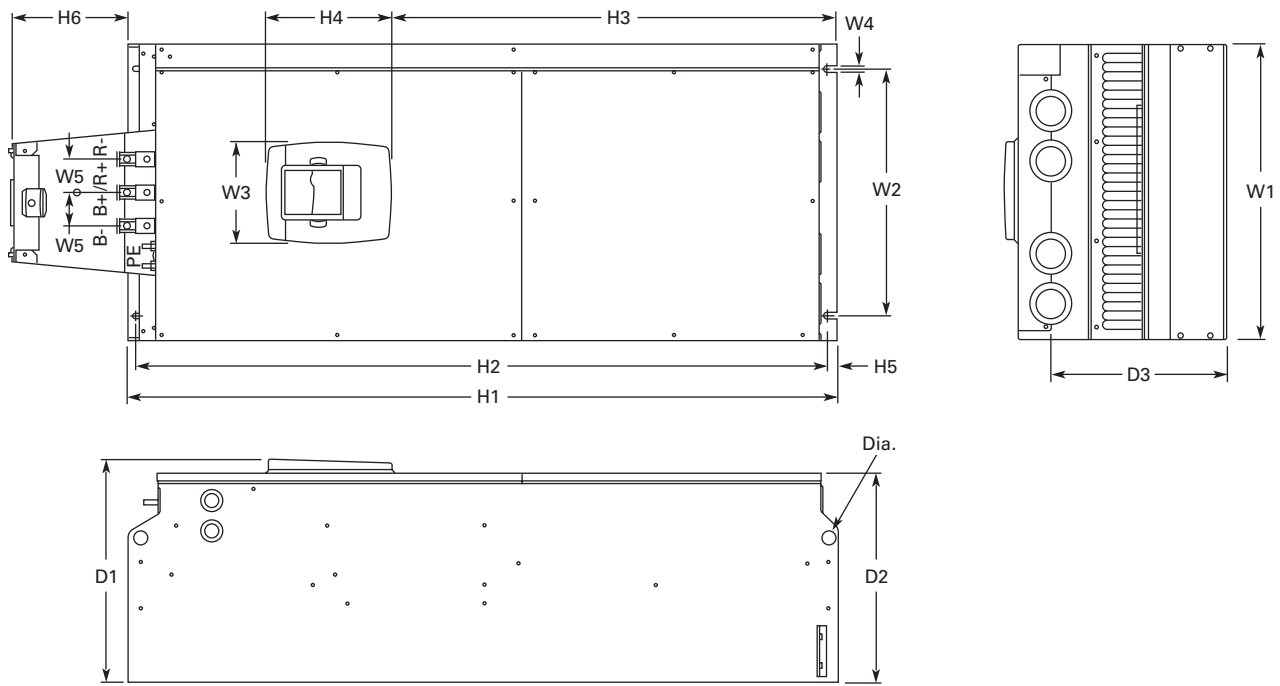

Voltage	hp (I _H)	W1	W2	W3	W4	H1	H2	H3	H4 ①	D1	D2	D3	Dia.	Weight Lbs (kg)
230V	75–100	18.9 (480)	15.7 (400)	0.4 (9)	2.1 (54)	45.3 (1150)	44.1 (1120)	0.6 (16)	7.4 (188)	14.2 (361.5)	13.4 (340)	11.2 (285)	0.8 (21)	321.9 (146)
480V	150–200													
575V	100–175													

Note

① Brake resistor terminal box (H6) included when brake chopper ordered.

Approximate Dimensions in Inches (mm)

NEMA Type 1/IP21 and NEMA Type 12/IP54, FR9 with Flange Kit

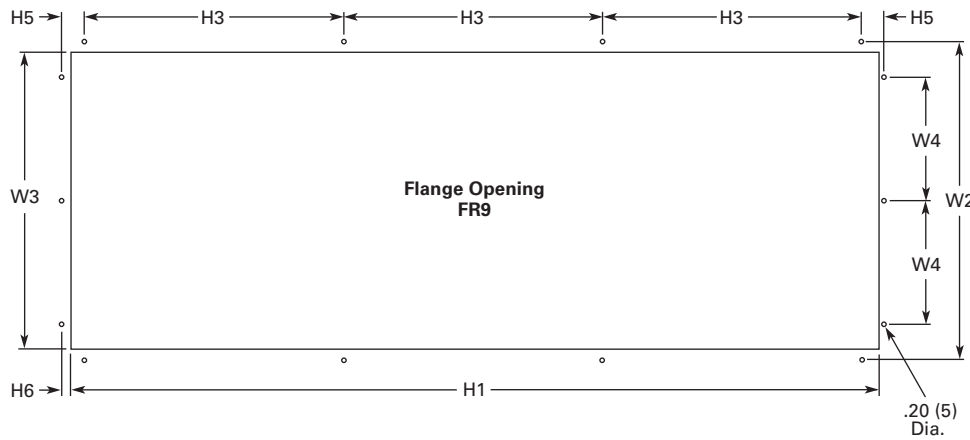
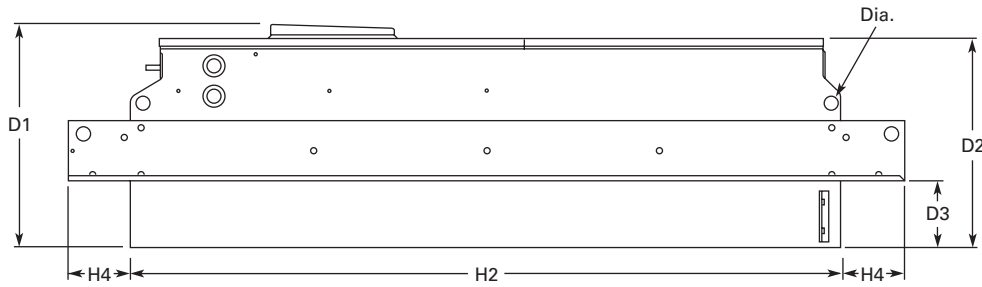
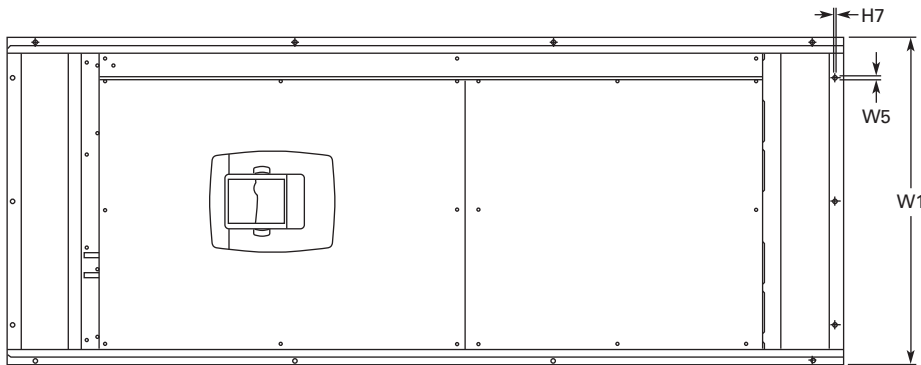

W1	W2	W3	W4	W5	H1	H2	H3	H4	H5	H6	H7	D1	D2	D3	Dia.
20.9 (530)	20.0 (510)	19.1 (485)	7.9 (200)	0.2 (5.5)	51.7 (1312)	45.3 (1150)	16.5 (420)	3.9 (100)	1.4 (35)	0.4 (9)	0.1 (2)	24.9 (362)	13.4 (340)	4.3 (109)	0.8 (21)

2.5

Adjustable Frequency Drives

SVX9000 Drives

Approximate Dimensions in Inches (mm)

NEMA Type 1/IP21 and NEMA Type 12/IP54, FR10 Freestanding

2

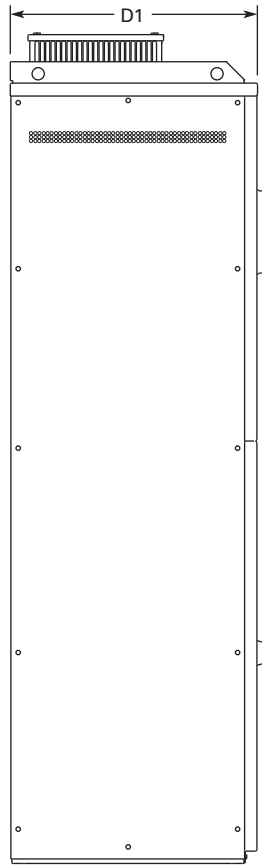
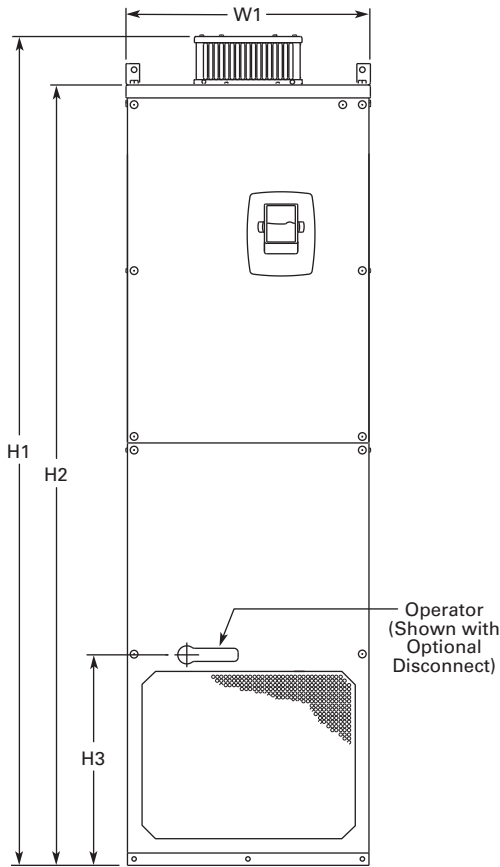
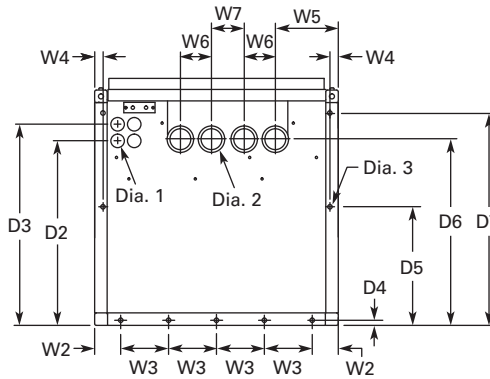
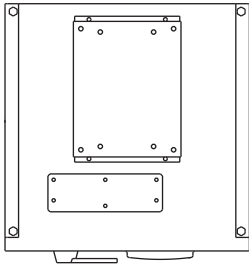

W1	W2	W3	W4	W5	W6	W7	H1	H2	H3	D1	D2	D3	D4	D5	D6	D7	Dia. 1	Dia. 2	Dia. 3	Weight Lbs (kg)
23.43 (595)	2.46 (62.5)	4.53 (115)	0.79 (20)	5.95 (151)	2.95 (75)	30.11 (79)	79.45 (2018)	74.80 (1900)	20.18 (512.5)	23.70 (602)	17.44 (443)	19.02 (483)	0.47 (12)	11.22 (285)	17.60 (447)	20.08 (510)	0.83 (21)	1.89 (48)	0.43 (11)	857 (389)

Approximate Dimensions in Inches (mm)

FR10 Open Chassis ①

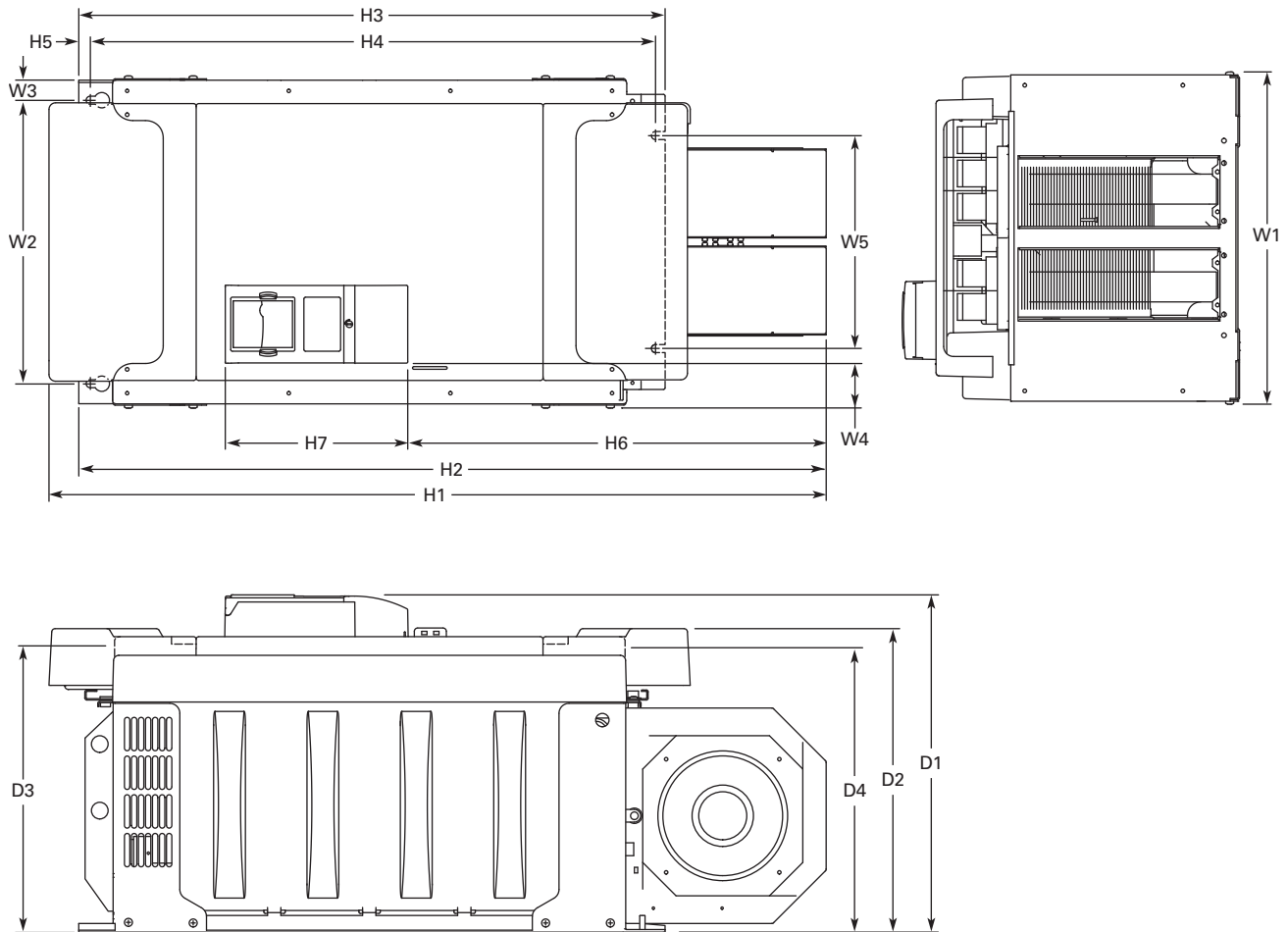

Voltage	hp (I _H)	W1	W2	W3	W4	W5	H1	H2	H3	H4	H5	H6	H7	D1	D2	D3	D4	Weight Lbs (kg)
480V	250–350	19.7	16.7	1.2	2.6	12.8	45.9	44.1	34.6	33.5	0.7	24.7	10.8	19.9	17.9	16.7	16.6	518
575V	200–300	(500)	(425)	(30)	(67)	(325)	(1165)	(1121)	(879)	(850)	(17)	(627)	(275)	(506)	(455)	(423)	(421)	(235)

Note

① 9000X FR12 is built of two FR10 modules. Please refer to SPX9000 installation manual for mounting instructions.

2.5

Adjustable Frequency Drives

SVX9000 Drives

Approximate Dimensions in Inches (mm)

NEMA Type 1/IP21, FR11 Freestanding Drive

2

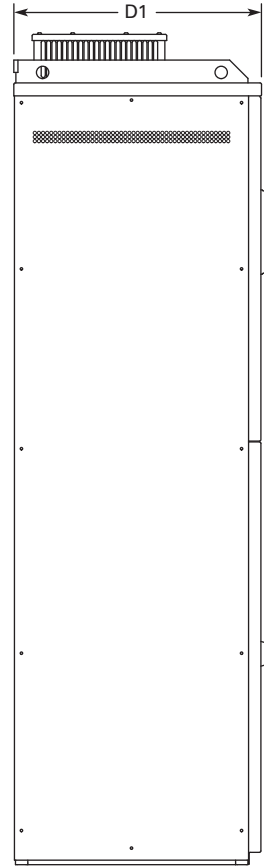
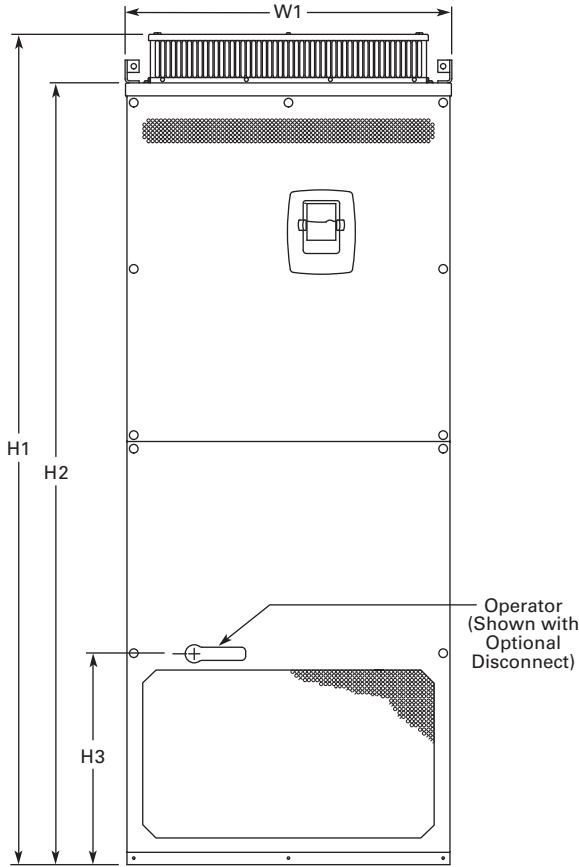
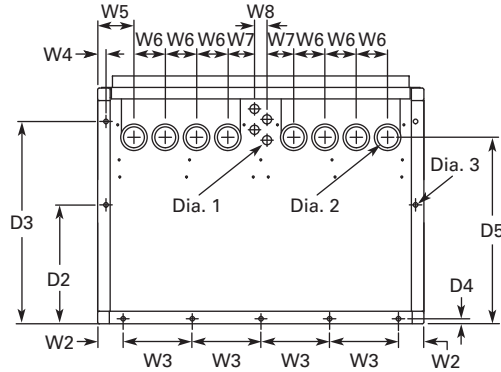
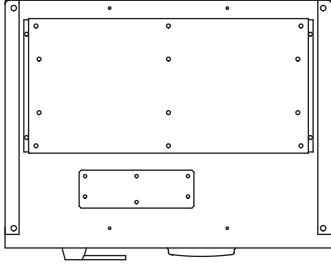

Voltage	hp (I _H)	W1	W2	W3	W4	W5	W6	W7	W8	H1	H2	H3	D1	D2	D3	D4	D5	Dia. 1	Dia. 2	Dia. 3	Weight Lbs (kg)
480	400-550	31.26 (794)	2.40 (61)	6.50 (165)	0.79 (20)	3.43 (87)	2.95 (75)	2.52 (64)	1.18 (30)	79.45 (2018)	74.80 (1900)	20.18 (512.5)	23.70 (602)	11.22 (285)	19.09 (485)	0.47 (12)	17.60 (447)	0.83 (21)	1.89 (48)	0.35 x 0.43 (9 x 11)	526 (239)

Approximate Dimensions in Inches (mm)

FR11 Open Chassis

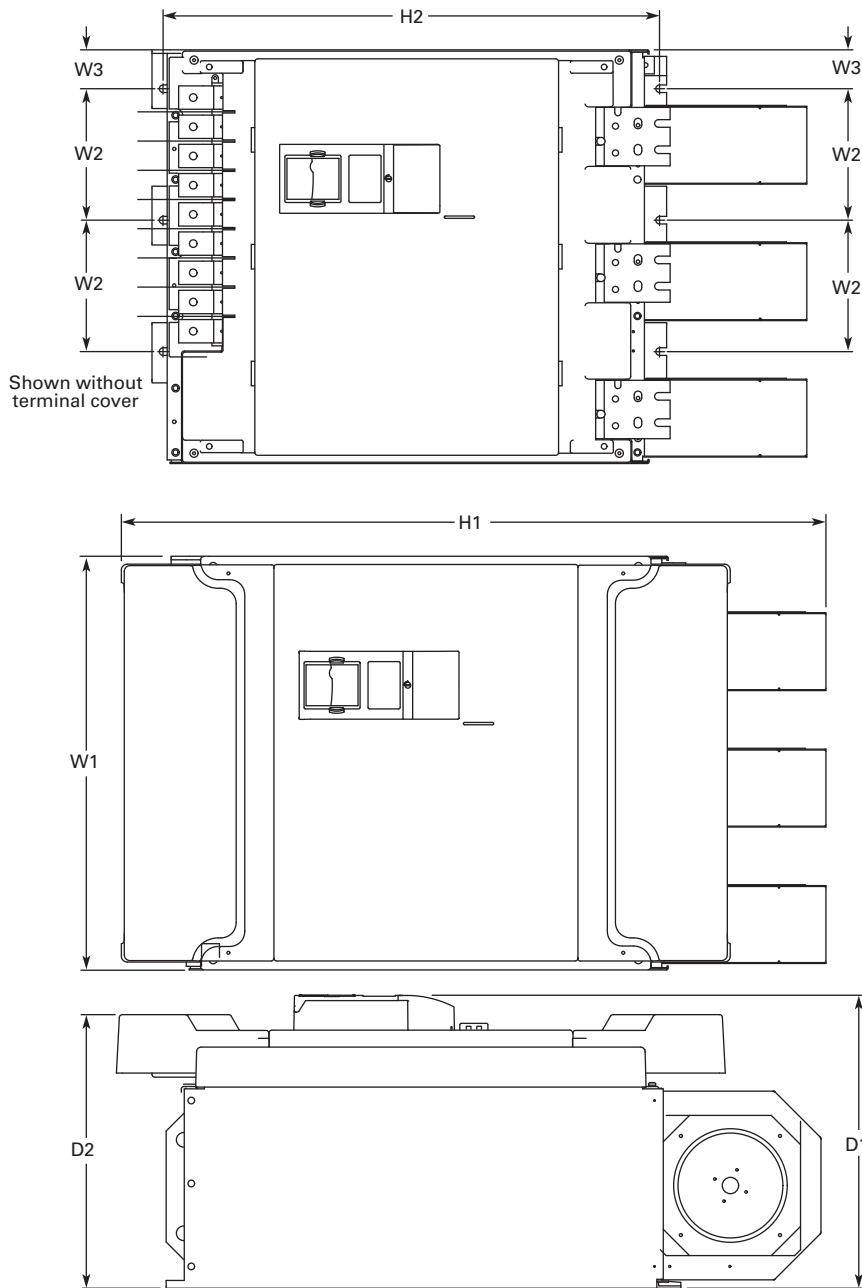

Voltage	hp (I _H)	W1	W2	W3	H1	H2	D1	D2	Weight Lbs (kg)
480V	400-550	27.9 (709)	8.86 (225)	2.6 (67)	45.5 (1155)	33.5 (850)	19.8 (503)	18.4 (468)	833 (378)
575V	400-500								

2.5

Adjustable Frequency Drives

SVX9000 Drives

Approximate Dimensions in Inches (mm)

FR13, Open Chassis Inverter

2

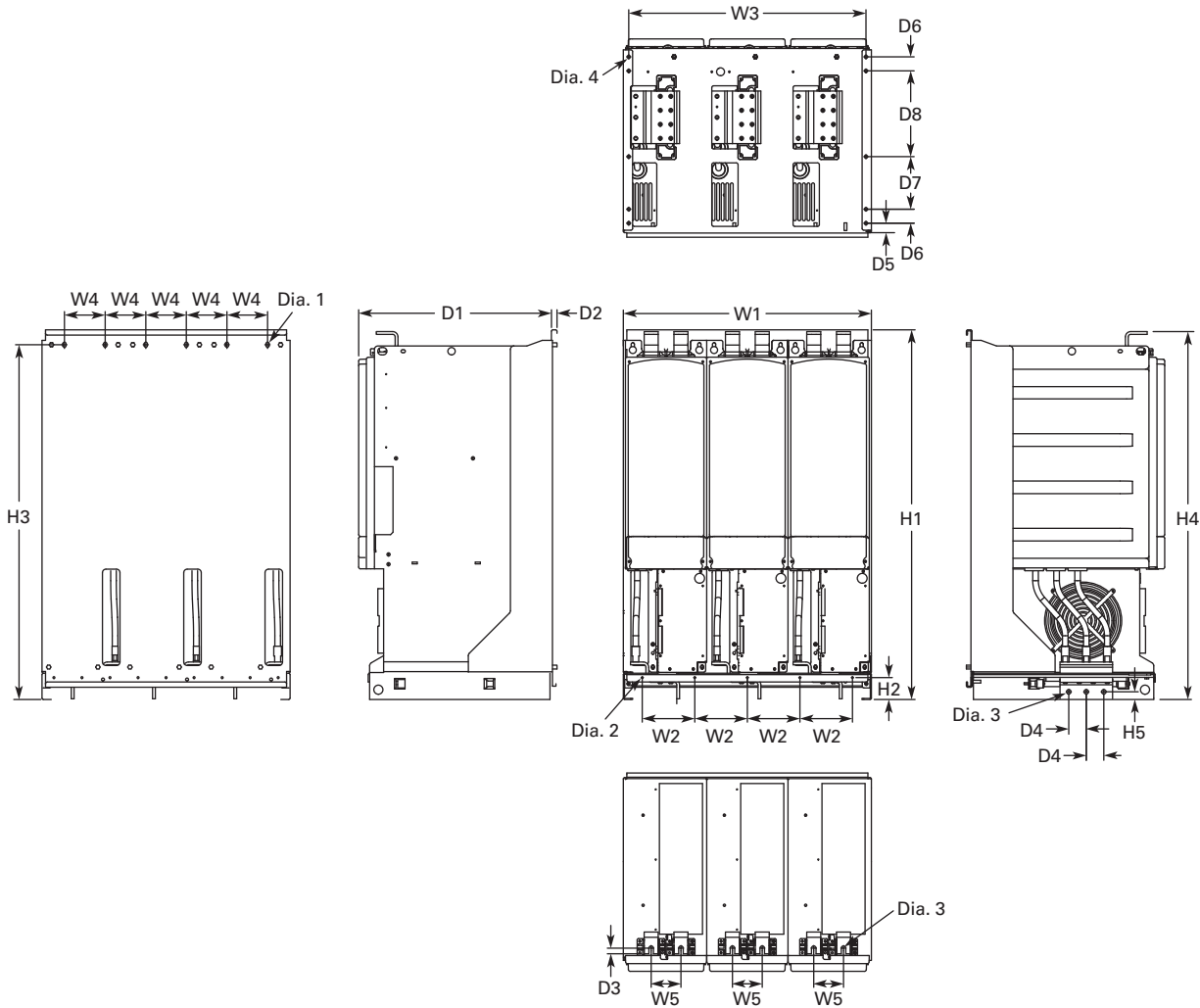

W1	W2	W3	W4	W5	H1	H2	H3	H4	H5	D1	D2	D3	D4	D5	D6	D7	D8	Dia. 1	Dia. 2	Dia. 3	Dia. 4	Weight Lbs (kg)
27.87	5.91	26.65	4.57	3.35	41.54	2.46	39.86	41.34	0.79	21.77	0.51	0.63	1.97	1.06	1.57	5.91	9.64	0.35x0.59	0.18	0.51	0.37	683
(708)	(150)	(677)	(116)	(85)	(1055)	(62.5)	(1012.5)	(1050)	(20)	(553)	(13)	(16)	(50)	(27)	(40)	(150)	(244.8)	(9x15)	(4.6)	(13)	(9.5)	(310)

Notes

9000X FR14 is built of two FR13 modules. Please refer to SPX9000 installation manual for mounting instructions.

FR13 is built from an inverter module and a converter module. Please refer to SPX9000 installation manual for mounting instructions.

Approximate Dimensions in Inches (mm)

FR13, Open Chassis Converter

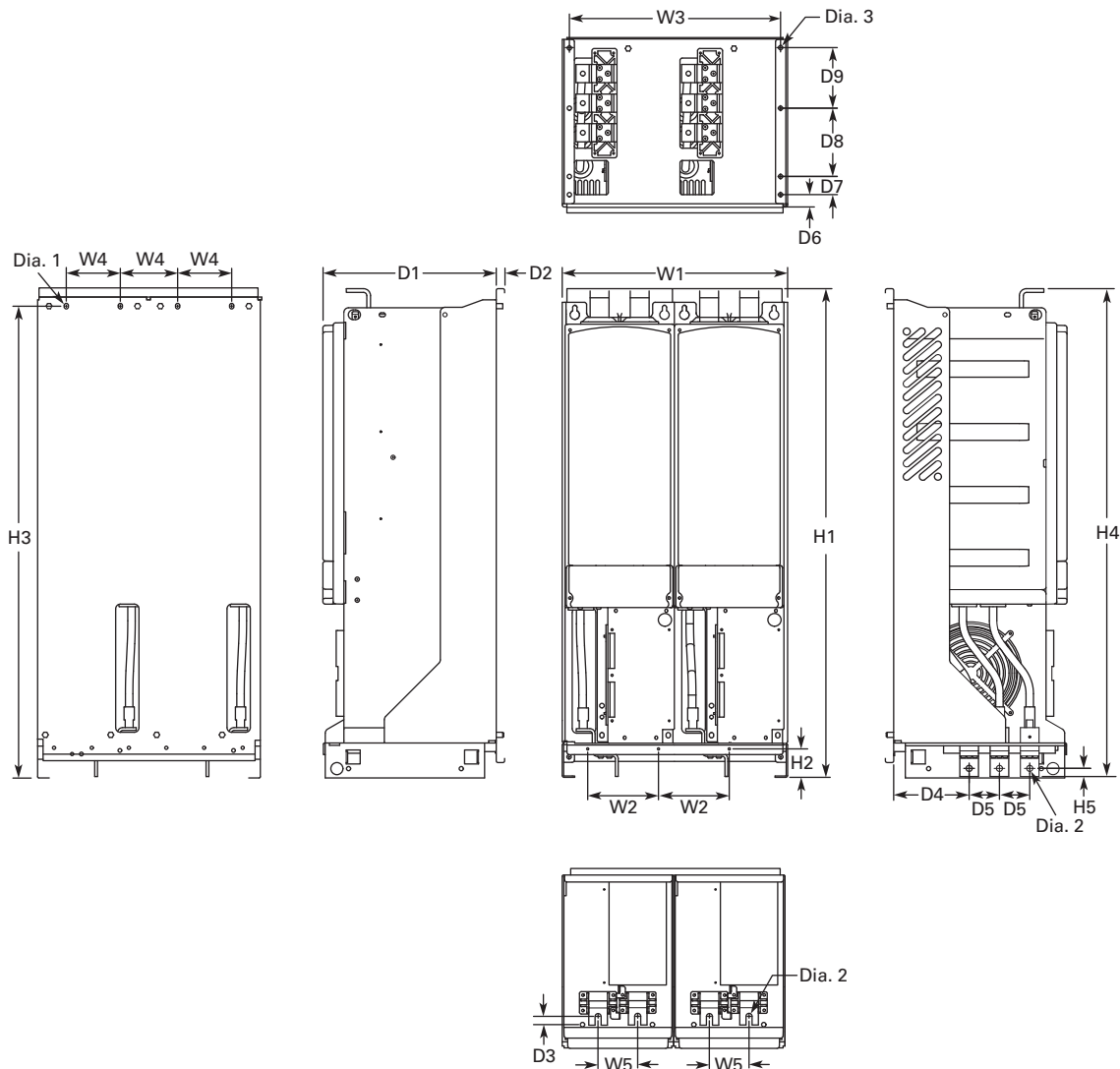

W1	W2	W3	W4	W5	H1	H2	H3	H4	H5	D1	D2	D3	D4	D5	D6	D7	D8	D9	Dia. 1	Dia. 2	Dia. 3	Weight Lbs (kg)
18.74 (476)	5.91 (150)	17.52 (445)	4.57 (116)	3.35 (85)	41.54 (1055)	2.46 (62.5)	39.86 (1012.5)	41.34 (1050)	0.69 (17.5)	14.69 (373)	0.51 (13)	0.73 (18.5)	6.42 (163)	2.56 (65)	1.06 (27)	1.57 (40)	5.91 (150)	5.24 (133)	0.35x0.59 (9x15)	0.51 (13)	0.37 (9.5)	295 (134)

Number of Input Units

480V Catalog Number	hp	Input Modules	690V Catalog Number	hp	Input Modules
SPX800A0-4A2N1	800	2	SPX800A0-5A2N1	800	2
			SPX900A0-5A2N1	900	2
			SPXH10A0-5A2N1	1000	2

2.5

Adjustable Frequency Drives

SVX9000 Drives

Approximate Dimensions in Inches (mm)

FR13, Open Chassis Converter — 900/1000 hp 480V

2

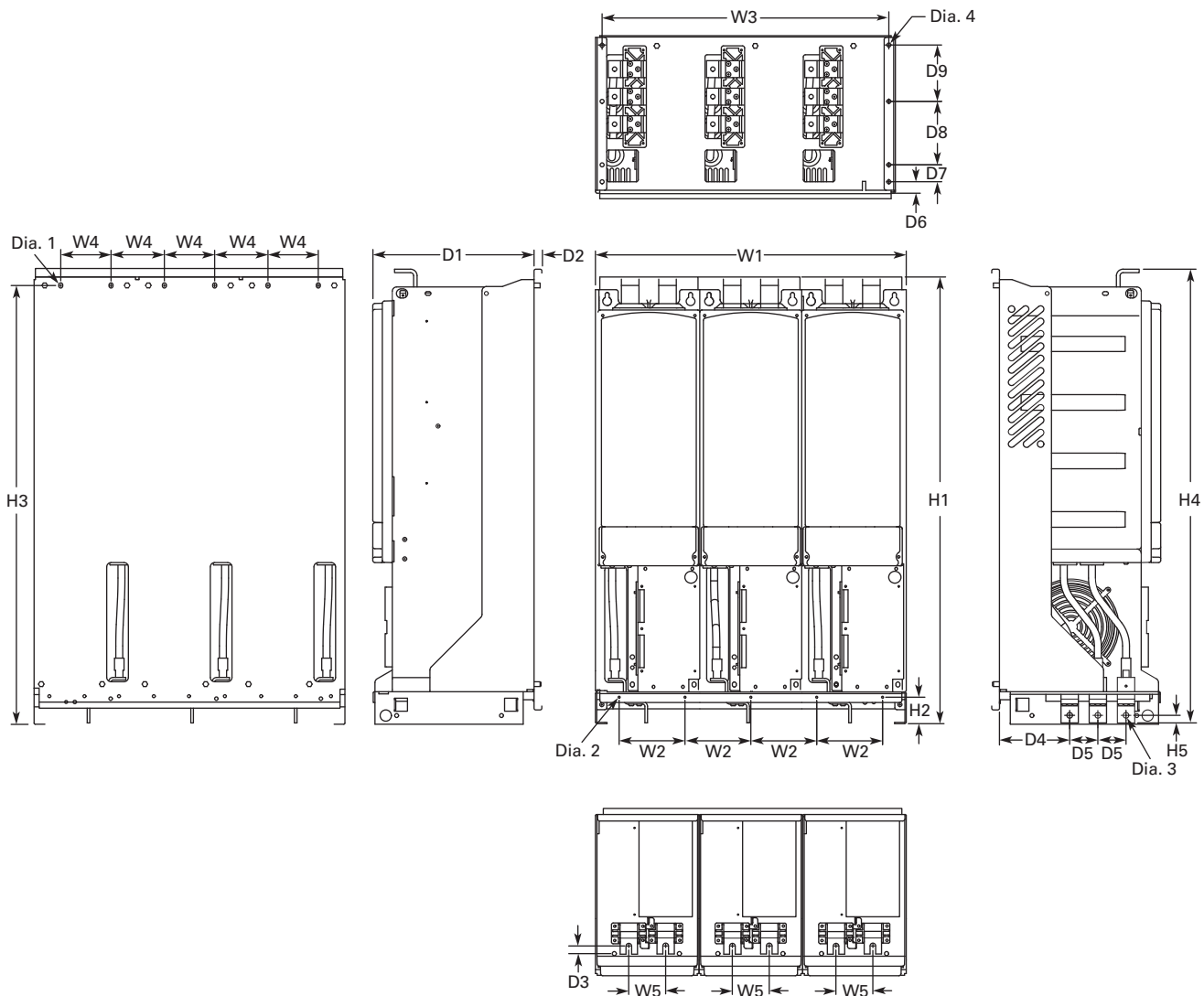

W1	W2	W3	W4	W5	H1	H2	H3	H4	H5	D1	D2	D3	D4	D5	D6	D7	D8	D9	Dia. 1	Dia. 2	Dia. 3	Dia. 4	Weight Lbs (kg)
27.87	5.91	26.65	4.57	3.35	41.54	2.46	39.86	41.34	0.69	14.69	0.51	0.73	6.42	2.56	1.06	1.57	5.91	5.24	0.35x0.59	0.18	0.51	0.37	443
(708)	(150)	(677)	(116)	(85)	(1055)	(62.5)	(1012.5)	(1050)	(17.5)	(373)	(13)	(18.5)	(163)	(65)	(27)	(40)	(150)	(133)	(9x15)	(4.6)	(13)	(9.5)	(201)

Number of Input Units

480V Catalog Number	hp	Input Modules
SPX900A0-4A2N1	900	3
SPXH10A0-4A2N1	1000	3

Approximate Dimensions in Inches (mm)

AC Choke Dimensions

Choke Types

Catalog Number	Frame Size	Choke Type ①	Catalog Number	Frame Size	Choke Type ①
Voltage Range 380–500V			Voltage Range 525–690V		
SPX 250 4	FR10	CHK0400	SPX 200 5	FR10	CHK0261
SPX 300 4		CHK0520	SPX 250 5		CHK0400
SPX 350 4		CHK0520	SPX 300 5		CHK0400
SPX 400 4	FR11	2 x CHK0400	SPX 400 5	FR11	CHK0520
SPX 500 4		2 x CHK0400	SPX 450 5		CHK0520
SPX 550 4		2 x CHK0400	SPX 500 5		2 x CHK0400
SPX 600 4	FR12	2 x CHK0520	SPX 550 5	FR12	2 x CHK0400
SPX 650 4		2 x CHK0520	SPX 600 5		2 x CHK0400
SPX 700 4		2 x CHK0520	SPX 700 5		2 x CHK0400
SPX 800 4	FR13	2 x CHK0400	SPX 800 5	FR13	2 x CHK0400
SPX 900 4		3 x CHK0520	SPX 900 5		2 x CHK0400
SPX H10 4		3 x CHK0520	SPX H10 5		2 x CHK0400
SPX H12 4	FR14	4 x CHK0520	SPX H13 5	FR14	4 x CHK0400
SPX H16 4		6 x CHK0400	SPX H15 5		6 x CHK0400

CHK0520

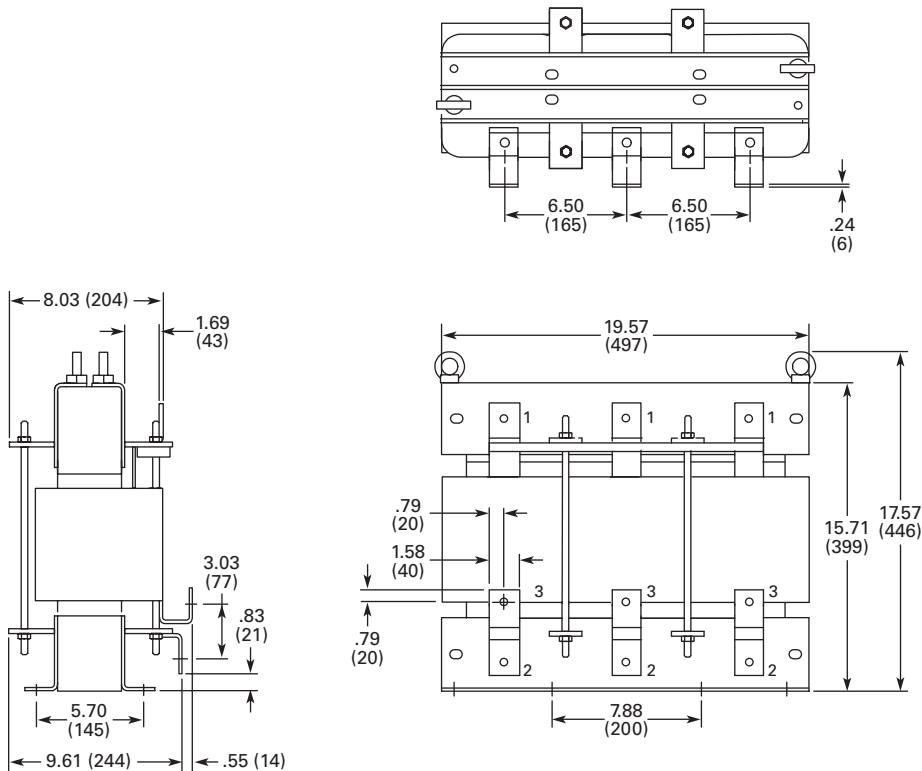

Note

① Chokes are provided with all FR10–FR14 drives.

2.5

Adjustable Frequency Drives

SVX9000 Drives

Approximate Dimensions in Inches (mm)

CHK0400

2

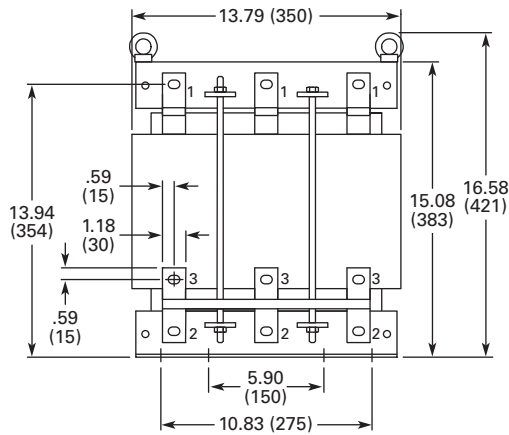
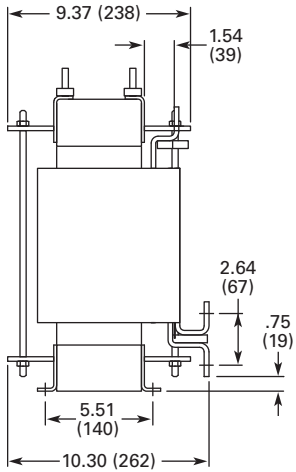
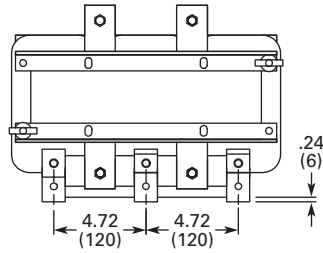

CHK0261

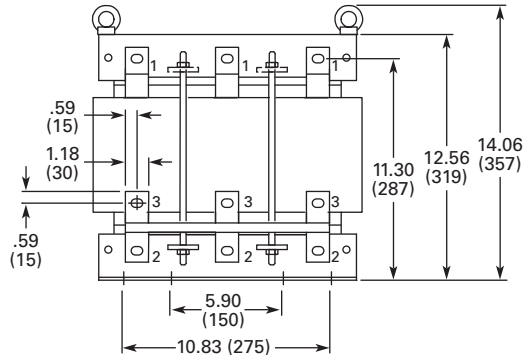
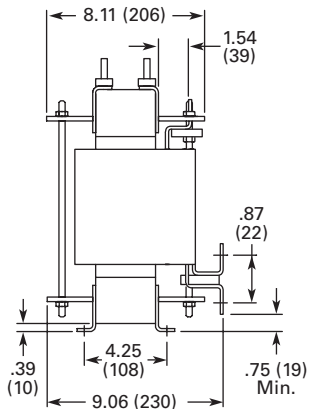
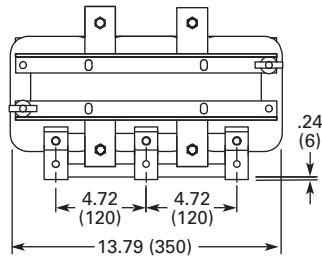

SVX9000 Enclosed Drives

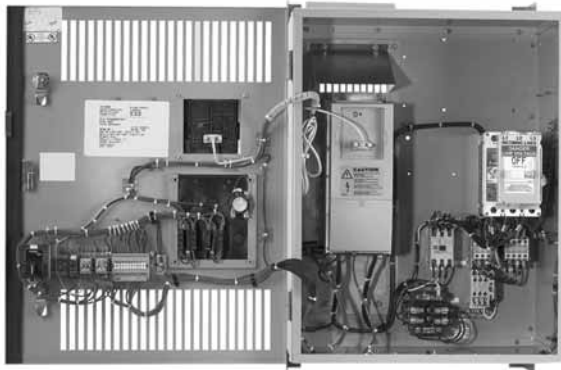

Contents

Description	Page
SVX9000 Drives	V6-T2-48
SVX9000 Enclosed Drives	
Product Identification	V6-T2-88
Catalog Number Selection	V6-T2-89
Product Selection	V6-T2-90
Options	V6-T2-94
Technical Data and Specifications	V6-T2-98
Dimensions	V6-T2-100
SVX9000 VFD Pump Panels	V6-T2-111

SVX9000 Enclosed Drives

Product Description

- **Standard Enclosed**—covers a wide range of the most commonly ordered options. Pre-engineering eliminates the lead time normally associated with customer specific options.
- **Modified Standard Enclosed**—applies to specific customer requirements that vary from the standard enclosed offering, such as the need for an additional indicating light or minor modifications to drawings. *Consult your Eaton representative for assistance in pricing and lead time.*
- **Custom Engineered**—for those applications with more unique or complex requirements, these are individually engineered to the customer's needs. *Consult your Eaton representative for assistance in pricing and lead time.*

Features

- NEMA Type 1/IP21 or NEMA Type 12/IP54 enclosures
- Input voltage: 208V, 230V, 480V and 575V (consult factory)
- Complete range of control, network and power options
- Horsepower range:
 - 208V—3/4 to 100 hp I_H; 1 to 100 hp I_L
 - 230V—3/4 to 100 hp I_H; 1 to 100 hp I_L
 - 480V—1 to 700 hp I_H; 1-1/2 to 800 hp I_L
- Padlockable disconnect

Standards and Certifications

- UL Listed
- cUL Listed



2.5

Adjustable Frequency Drives

SVX9000 Drives

Product Identification

Enclosed 9000X Series Drive

2

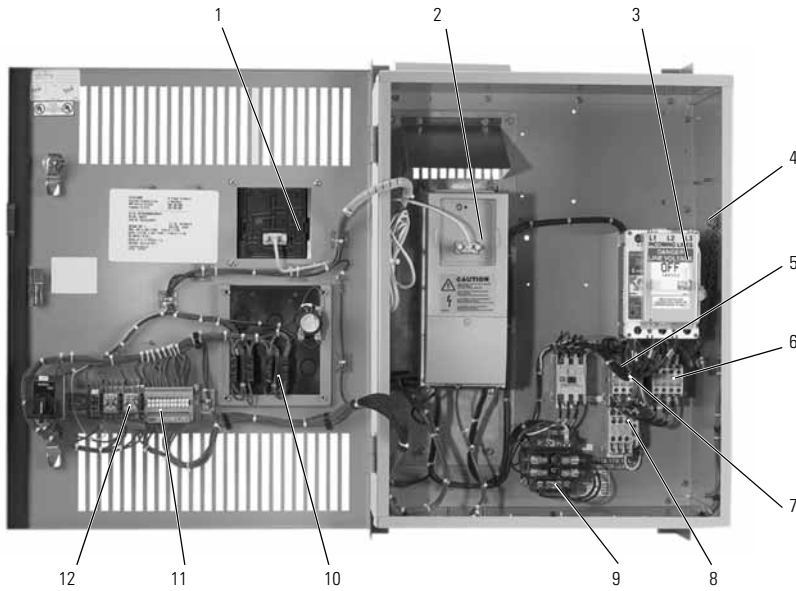

- | | | |
|-----------------------------------------------------------------|-----------------------------------------------------------------------------|----------------------------------------------------------------------------------------------------------|
| 1 Door mounted keypad (included as standard with bypass option) | 6 Output contactor
• Option PE (included as standard with bypass option) | 9 115V control transformer
• Option KB |
| 2 SVX9000 variable frequency drive | 7 Bypass contactor
• Option RA
• Option RB | 10 Bypass pilot lights and selector switches
• Option RA
• Option RB
• Option L2
• Option KF |
| 3 Input disconnect
• Option P1 | 8 Overload relay
• Option PH
• Option PI | 11 Customer control and signal connection terminal block |
| 4 Input line fuses
• Option P3 | | 12 Control relay |
| 5 Input contactor (included as standard with bypass option) | | |

Catalog Number Selection

SVX9000 Enclosed NEMA Type 1/IP21 and NEMA Type 12/IP54 Drives

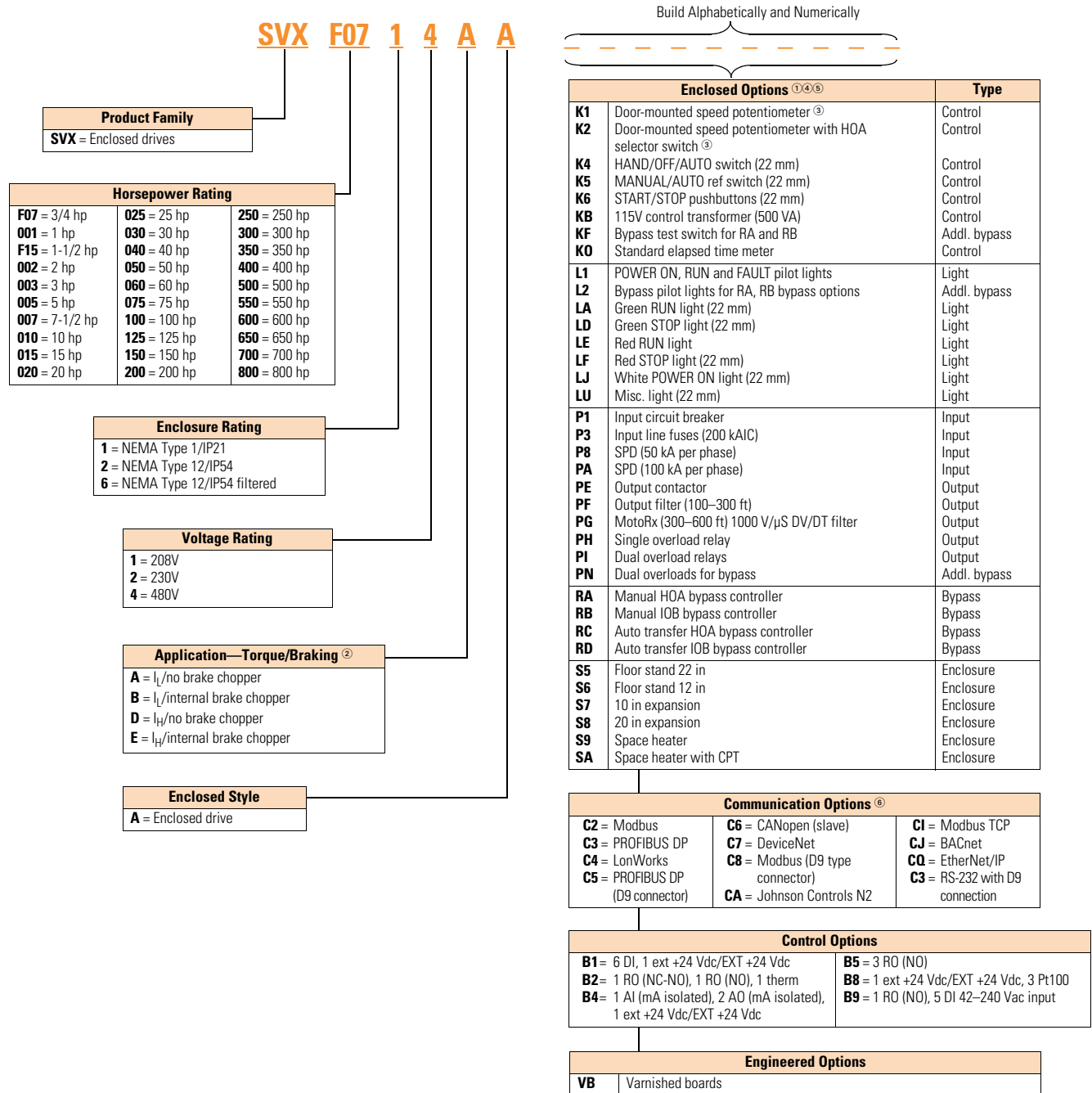

Notes

- ① Local/remote keypad is included as the standard control panel.
- ② Brake chopper is a factory installed option only, see drive options on **Page V6-T2-49**. External dynamic braking resistors not included. Consult factory.
- ③ Includes local/remote speed reference switch.
- ④ Some options are voltage and/or horsepower specific. Consult your Eaton representative for details.
- ⑤ See **Pages V6-T2-96** and **V6-T2-97** for descriptions.
- ⑥ See **Pages V6-T2-94** and **V6-T2-95** for complete descriptions.

2.5

Adjustable Frequency Drives

SVX9000 Drives

Product Selection

When Ordering

- Select a base catalog number that meets the application requirements—nominal horsepower, voltage and enclosure rating (the enclosed drive's continuous output amp rating should be equal to or greater than the motor's full load amp rating). The base enclosed package includes a standard drive, door mounted local/remote keypad and enclosure.
- If dynamic brake chopper or control/communication option is desired, change the appropriate code in the base catalog number.
- Select enclosed options. Add the codes as suffixes to the base catalog number in alphabetical and numeric order.
- **Read all footnotes.**

208V Drives

SVX9000 Enclosed Drives



Input Base Drives

Enclosure Size ①	hp	Current (A)	NEMA Type 1/IP21		NEMA Type 12/IP54	
			Frame Size	Base Catalog Number ②	Frame Size	Base Catalog Number ②
High Overload Drive and Enclosure						
0	3/4	3.7	4	SVXF0711EA	4	SVXF0721EA
	1	4.8		SVX00111EA		SVX00121EA
	1-1/2	6.6		SVXF1511EA		SVXF1521EA
	2	7.8		SVX00211EA		SVX00221EA
	3	11		SVX00311EA		SVX00321EA
	5	17.5	5	SVX00511EA	5	SVX00521EA
	7-1/2	25		SVX00711EA		SVX00721EA
1	10	31	6	SVX01011EA	6	SVX01021EA
	15	48		SVX01511EA		SVX01521EA
2	20	61	7	SVX02011DA	7	SVX02021DA
	25	75		SVX02511DA		SVX02521DA
	30	88		SVX03011DA		SVX03021DA
3	40	114	8	SVX04011DA	8	SVX04021DA
4	50	143	8	SVX05011DA	8	SVX05021DA
5	60	170	8	SVX06011DA	8	SVX06021DA
	75	211	9	SVX07511DA	9	SVX07521DA
	100	273		SVX10011DA		SVX10021DA
Low Overload Drive and Enclosure						
0	1	4.8	4	SVX00111BA	4	SVX00121BA
	1-1/2	6.6		SVXF1511BA		SVXF1521BA
	2	7.8		SVX00211BA		SVX00221BA
	3	11		SVX00311BA		SVX00321BA
	5	17.5	5	SVX00511BA	5	SVX00521BA
	7-1/2	25		SVX00711BA		SVX00721BA
	10	31		SVX01011BA		SVX01021BA
1	15	48	6	SVX01511BA	6	SVX01521BA
	20	61		SVX02011BA		SVX02021BA
2	25	75	7	SVX02511AA	7	SVX02521AA
	30	88		SVX03011AA		SVX03021AA
	40	114		SVX04011AA		SVX04021AA
3	50	—	8	SVX05011AA	8	SVX05021AA
4	60	170	8	SVX06011AA	8	SVX06021AA
5	75 ③	205	8	SVX07511AA	8	SVX07521AA
	100 ③	261	9	SVX10011AA	9	SVX10021AA

Notes

For brake chopper options, see **Page V6-T2-58**.

① See enclosure dimensions starting on **Page V6-T2-100**.

② Includes drive, local/remote keypad and enclosure.

③ These units are current rated (75 I_L hp 205 amps, 100 I_L hp 261 amps). They do not meet NEC ampere ratings.

230V Drives

SVX9000 Enclosed Drives



Input Base Drives

Enclosure Size ①	hp	Current (A)	NEMA Type 1/IP21		NEMA Type 12/IP54	
			Frame Size	Base Catalog Number ②	Frame Size	Base Catalog Number ②
High Overload Drive and Enclosure						
0	3/4	3.7	4	SVXF0712EA	4	SVXF0722EA
	1	4.8		SVX00112EA		SVX00122EA
	1-1/2	6.6		SVXF1512EA		SVXF1522EA
	2	7.8	SVX00212EA	SVX00222EA		
	3	11	SVX00312EA	SVX00322EA		
	5	17.5	5	SVX00512EA	SVX00522EA	
7-1/2	25	SVX00712EA		SVX00722EA		
1	10	31	6	SVX01012EA	SVX01022EA	
	15	48		SVX01512EA	SVX01522EA	
2	20	61	7	SVX02012DA	SVX02022DA	
	25	75		SVX02512DA	SVX02522DA	
	30	88		SVX03012DA	SVX03022DA	
3	40	114	8	SVX04012DA	SVX04022DA	
4	50	140	8	SVX05012DA	SVX05022DA	
5	60	170	8	SVX06012DA	SVX06022DA	
	75	205		9	SVX07522DA	
	100 ③	261	9	SVX10012DA	SVX10022DA	
Low Overload Drive and Enclosure						
0	1	4.8	4	SVX00112BA	4	SVX00122BA
	1-1/2	6.6		SVXF1512BA		SVXF1522BA
	2	7.8		SVX00212BA		SVX00222BA
	3	11	SVX00312BA	SVX00322BA		
	5	17.5	5	SVX00512BA	SVX00522BA	
	7-1/2	25		SVX00712BA	SVX00722BA	
10	31		SVX01012BA	SVX01022BA		
1	15	48	6	SVX01512BA	SVX01522BA	
	20	61		SVX02012BA	SVX02022BA	
2	25	75	7	SVX02512AA	SVX02522AA	
	30	88		SVX03012AA	SVX03022AA	
	40	114		SVX04012AA	SVX04022AA	
3	50	140	8	SVX05012AA	SVX05022AA	
4	60	170	8	SVX06012AA	SVX06022AA	
5	75	205	8	SVX07512AA	SVX07522AA	
	100 ③	261		9	SVX10012AA	SVX10022AA

Notes

For brake chopper options, see **Page V6-T2-58**.

① See enclosure dimensions starting on **Page V6-T2-100**.

② Includes drive, local/remote keypad and enclosure.

③ This unit is current rated (100 I_L hp 100 amps, 261 I_L hp). It is not hp rated. They do not meet NEC ampere ratings.

480V Drives

SVX9000 Enclosed Drives

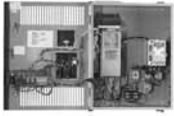

Input Base Drives

2

Enclosure Size ①	hp	Current (A)	NEMA Type 1/IP21		NEMA Type 12/IP54	
			Frame Size	Base Catalog Number ②	Frame Size	Base Catalog Number ②
High Overload Drive and Enclosure						
0	1	2.2	4	SVX00114EA	4	SVX00124EA
	1-1/2	3.3		SVXF1514EA		SVXF1524EA
	2	4.3		SVX00214EA		SVX00224EA
	3	5.6	SVX00314EA	SVX00324EA		
	5	7.6	SVX00514EA	SVX00524EA		
	7-1/2	12	5	SVX00714EA		SVX00724EA
	10	16		SVX01014EA		SVX01024EA
15	23	SVX01514EA		SVX01524EA		
1	20	31	6	SVX02014EA	6	SVX02024EA
	25	38		SVX02514EA		SVX02524EA
	30	46		SVX03014EA		SVX03024EA
2	40	61	7	SVX04014DA	7	SVX04024DA
	50	72		SVX05014DA		SVX05024DA
	60	87		SVX06014DA		SVX06024DA
3	75	105	8	SVX07514DA	8	SVX07524DA
	100	140		SVX10014DA		SVX10024DA
4	125	170	8	SVX12514DA	8	SVX12524DA
5	150	205	9	SVX15014DA	9	SVX15024DA
	200	245		SVX20014DA		SVX20024DA
6, 8 ③④	250	300	10	SVX25014DA	10	SVX25064DA
	300	385		SVX30014DA		SVX30064DA
	350	460		SVX35014DA		SVX35064DA
8, 9 ④⑤	400	520	11	SVX40014DA	11	SVX40064DA
	500	590		SVX50014DA		SVX50064DA
	550	650		SVX55014DA		SVX55064DA
⑥	600	730	12	SVX60014DA	12	SVX60064DA
	650	820		SVX65014DA		SVX65064DA
	700	920		SVX70014DA		SVX70064DA

Notes

For brake chopper options, see **Page V6-T2-58**.

① See enclosure dimensions starting on **Page V6-T2-100**.

② Includes drive, local/remote keypad and enclosure.

③ The smaller enclosure Size 6 accommodates only power options, input disconnect (P1) and input line fuses (P3). Bypass and other options require Size 8. Adding any standard control option will not require the larger enclosure.

④ For other options, consult factory.

⑤ The smaller enclosure Size 8 accommodates only power options, input disconnect (P1) and input line fuses (P3). Bypass and other options require Size 9. Adding any standard control option will not require the larger enclosure.

⑥ Consult factory.

SVX9000 Enclosed Drives



Input Base Drives, continued

Enclosure Size ^①	hp	Current (A)	NEMA Type 1/IP21		NEMA Type 12/IP54	
			Frame Size	Base Catalog Number ^②	Frame Size	Base Catalog Number ^②
Low Overload Drive and Enclosure						
0	1-1/2	3.3	4	SVXF1514BA	4	SVXF1524BA
	2	4.3		SVX00214BA		SVX00224BA
	3	5.6		SVX00314BA		SVX00324BA
	5	7.6		SVX00514BA		SVX00524BA
	7-1/2	12	SVX00714BA	SVX00724BA		
	10	16	5	SVX01014BA	SVX01024BA	
	15	23		SVX01514BA	SVX01524BA	
	20	31		SVX02014BA	SVX02024BA	
1	25	38		6	SVX02514BA	SVX02524BA
	30	46	SVX03014BA	SVX03024BA		
	40	61	SVX04014BA	SVX04024BA		
2	50	72	7	SVX05014AA	SVX05024AA	
	60	87		SVX06014AA	SVX06024AA	
	75	105		SVX07514AA	SVX07524AA	
3	100	140	8	SVX10014AA	SVX10024AA	
4	125	170	8	SVX12514AA	SVX12524AA	
	150	205		SVX15014AA	SVX15024AA	
5	200	261	9	SVX20014AA	SVX20024AA	
	250	300		SVX25014AA	SVX25024AA	
6, 8 ^{③④}	300	385	10	SVX30014AA	SVX30064AA	
	350	460		SVX35014AA	SVX35064AA	
	400	520		SVX40014AA	SVX40064AA	
8, 9 ^{④⑤}	500	590	11	SVX50014AA	SVX50064AA	
	550	650		SVX55014AA	SVX55064AA	
	600	730		SVX60014AA	SVX60064AA	
⑥	650	820	12	SVX65014AA	SVX65064AA	
	700	920		SVX70014AA	SVX70064AA	
	800	1030		SVX80014AA	SVX80064AA	

Notes

For brake chopper options, see **Page V6-T2-58**.

^① See enclosure dimensions starting on **Page V6-T2-100**.

^② Includes drive, local/remote keypad and enclosure.

^③ The smaller enclosure Size 6 accommodates only power options, input disconnect (P1) and input line fuses (P3). Bypass and other options require Size 8. Adding any standard control option will not require the larger enclosure.

^④ For other options, consult factory.

^⑤ The smaller enclosure Size 8 accommodates only power options, input disconnect (P1) and input line fuses (P3). Bypass and other options require Size 9. Adding any standard control option will not require the larger enclosure.

^⑥ Consult factory.

Options

9000X Series Option Board Kits

2

The 9000X Series drives can accommodate a wide selection of expander and adapter option boards to customize the drive for your application needs. The drive's control unit is designed to accept a total of five option boards.

The 9000X Series factory installed standard board configuration includes an A9 I/O board and an A2 relay output board, which are installed in slots A and B.

Option Boards

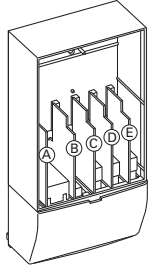

Option Board Kits

Option Kit Description ^①	Allowed Slot Locations ^②	Field Installed Catalog Number	Factory Installed Option Designator	SVX Ready Programs						
				Basic	Local/Remote	Standard	MSS	PID	Multi-P.	PFC
Standard I/O Cards										
6 DI, 1 DO, 2 AI, 1AO, 1 +10 Vdc ref, 2 ext +24 Vdc/EXT +24 Vdc	A	OPTA9	—	■	■	■	■	■	■	■
2 RO (NC-NO)	B	OPTA2	—	■	■	■	■	■	■	■
Extended I/O Cards										
2 RO, therm—SPX only	B	OPTA3	A3	—	■	■	■	■	■	■
Encoder low volt +5V/15V/24V—SPX only	C	OPTA4	A4	—	■	■	■	■	■	■
Encoder high volt +15V/24V—SPX only	C	OPTA5	A5	—	■	■	■	■	■	■
Double encoder—SPX only	C	OPTA7	A7	■	■	■	■	■	■	■
6 DI, 1 DO, 2 AI, 1 AO—SPX only	A	OPTA8	A8	—	■	■	■	■	■	■
3 DI (encoder 10–24V), out +15V/+24V, 2 DO (pulse+direction)—SPX only	C	OPTAE	AE	■	■	■	■	■	■	■
6 DI, 1 ext +24 Vdc/EXT +24 Vdc	B, C, D , E	OPTB1	B1	—	—	—	—	—	■	■
1 RO (NC-NO), 1 RO (NO), 1 therm	B, C, D , E	OPTB2	B2	—	—	—	—	—	■	■
1 AI (mA isolated), 2 AO (mA isolated), 1 ext +24 Vdc/EXT +24 Vdc	B, C, D , E	OPTB4	B4	■	■	■	■	■	■	■
3 RO (NO)	B, C, D , E	OPTB5	B5	—	—	—	—	—	■	■
1 ext +24 Vdc/EXT +24 Vdc, 3 Pt100	B, C, D , E	OPTB8	B8	—	—	—	—	—	—	—
1 RO (NO), 5 DI 42–240 Vac input	B, C, D , E	OPTB9	B9	—	—	—	—	—	■	■
Communication Cards										
Modbus ^③	D, E	OPTC2	C2	■	■	■	■	■	■	■
Modbus TCP	D, E	OPTCI	CI	■	■	■	■	■	■	■
BACnet	D, E	OPTCJ	CJ	■	■	■	■	■	■	■
EtherNet/IP	D, E	OPTCQ	CQ	■	■	■	■	■	■	■
Johnson Controls N2 ^③	D, E	OPTC2	CA	—	—	—	—	—	—	—
PROFIBUS DP	D, E	OPTC3	C3	■	■	■	■	■	■	■
LonWorks	D, E	OPTC4	C4	■	■	■	■	■	■	■
PROFIBUS DP (D9 connector)	D, E	OPTC5	C5	■	■	■	■	■	■	■
CANopen (slave)	D, E	OPTC6	C6	■	■	■	■	■	■	■
DeviceNet	D, E	OPTC7	C7	■	■	■	■	■	■	■
Modbus (D9 type connector)	D, E	OPTC8	C8	■	■	■	■	■	■	■
Adapter—SPX only	D, E	OPTD1	D1	■	■	■	■	■	■	■
Adapter—SPX only	D, E	OPTD2	D2	■	■	■	■	■	■	■
RS-232 with D9 connection	D, E	OPTD3	D3	■	■	■	■	■	■	■

Notes

- ① AI = Analog Input; AO = Analog Output, DI = Digital Input, DO = Digital Output, RO = Relay Output
- ② Option card must be installed in one of the slots listed for that card. Slot indicated in bold is the preferred location.
- ③ OPTC2 is a multi-protocol option card.

Modbus RTU Network Communications

The Modbus Network Card OPTC2 is used for connecting the 9000X Drive as a slave on a Modbus network. The interface is connected by a 9-pin DSUB connector (female) and the baud rate ranges from 300 to 19200 baud. Other communication parameters include an address range from 1 to 247; a parity of None, Odd or Even; and the stop bit is 1.

PROFIBUS Network Communications

The PROFIBUS Network Card OPTC3 is used for connecting the 9000X Drive as a slave on a PROFIBUS-DP network. The interface is connected by a 9-pin DSUB connector (female). The baud rates range from 9.6K baud to 12M baud, and the addresses range from 1 to 127.

LonWorks Network Communications

The LonWorks Network Card OPTC4 is used for connecting the 9000X Drive on a LonWorks network. This interface uses Standard Network Variable Types (SNVT) as data types. The channel connection is achieved using a FTT-10A Free Topology transceiver via a single twisted transfer cable. The communication speed with LonWorks is 78 kBits/s.

CANopen (Slave) Communications

The CANopen (Slave) Network Card OPTC6 is used for connecting the 9000X Drive to a host system. According to ISO11898 standard cables to be chosen for CAN bus should have a nominal impedance of 120 ohms, and specific line delay of nominal 5 nS/m. 120 ohms line termination resistors required for installation.

DeviceNet Network Communications

The DeviceNet Network Card OPTC7 is used for connecting the 9000X Drive on a DeviceNet Network. It includes a 5.08 mm pluggable connector. Transfer method is via CAN using a two-wire twisted shielded cable with two-wire bus power cable and drain. The baud rates used for communication include 125K baud, 250K baud and 500K baud.

Johnson Controls Metasys N2 Network Communications

The OPTC2 fieldbus board provides communication between the 9000X Drive and a Johnson Controls Metasys™ N2 network. With this connection, the drive can be controlled, monitored and programmed from the Metasys system. The N2 fieldbus is available as a factory installed option and as a field installable kit.

Modbus/TCP Network Communications

The Modbus/TCP Network Card OPTCI is used for connecting the 9000X Drive to Ethernet networks utilizing Modbus protocol. It includes an RJ-45 pluggable connector. This interface provides a selection of standard and custom register values to communicate drive parameters. The board supports 10 Mbps and 100 Mbps communication speeds. The IP address of the board is configurable over Ethernet using a supplied software tool.

BACnet Network Communications

The BACnet Network Card OPTCJ is used for connecting the 9000X Drive to BACnet networks. It includes a 5.08 mm pluggable connector. Data transfer is Master-Slave/Token Passing (MS/TP) RS-485. This interface uses a collection of 30 Binary Value Objects (BVOs) and 35 Analog Value Objects (AVOs) to communicate drive parameters. The card supports 9.6, 19.2 and 38.4 Kbaud communication speeds and supports network addresses 1–127.

EtherNet/IP Network Communications

The EtherNet/IP Network Card OPTCK is used for connecting the 9000X Drive to Ethernet/Industrial Protocol networks. It includes an RJ-45 pluggable connector. The interface uses CIP objects to communicate drive parameters (CIP is “Common Industrial Protocol”, the same protocol used by DeviceNet). The board supports 10 Mbps and 100 Mbps communication speeds. The IP address of the board is configurable by Static, BOOTP and DHCP methods.

Control/Communication Option Descriptions

For availability, see Product Selection for base drive voltage required.

2

Available Control/Communications Options

Option	Description	Option Type
K1	Door-Mounted Speed Potentiometer —Provides the SVX9000 with the ability to adjust the frequency reference using a door-mounted potentiometer. This option uses the 10 Vdc reference to generate a 0–10V signal at the analog voltage input signal terminal. When the HOA bypass option is added, the speed is controlled when the HOA switch is in the HAND position. Without the HOA bypass option, a two-position switch (labeled local/remote) is provided on the keypad to select speed reference from the speed potentiometer or a remote speed signal.	Control
K2	Door-Mounted Speed Potentiometer with HOA Selector Switch —Provides the SVX9000 with the ability to start/stop and adjust the speed reference from door-mounted control devices or remotely from customer supplied inputs. In HAND position, the drive will start and the speed is controlled by the door-mounted speed potentiometer. The drive will be disabled in the OFF position. When AUTO is selected, the drive run and speed control commands are via user-supplied dry contact and 4–20 mA signal.	Control
K4	HAND/OFF/AUTO Switch for Non-Bypass Configurations —Provides a three-position selector switch that allows the user to select either a HAND or AUTO mode of operation. HAND mode is defaulted to k (keypad operation, and AUTO mode is defaulted to control from an external terminal source. These modes of operation can be configured via programming to allow for alternate combinations of start and speed sources. Start and speed sources include keypad, I/O and fieldbus.	Control
K5	MANUAL/AUTO Speed Reference Switch —Provides a door-mounted selector switch for MANUAL/AUTO speed reference.	Control
K6	START/STOP Pushbuttons —Provide door-mounted START and STOP pushbuttons for either bypass or non-bypass configurations.	Control
KB	115V Control Transformer, 500 VA —Provides a fused control power transformer with additional 500 VA at 115V for customer use.	Control
KF	Bypass Test Switch for RB and RA —Allows the user to energize the AF drive for testing while operating the motor on the bypass controller. The test switch is mounted on the inside of the enclosure door.	Add. bypass
K0	Standard Elapsed Time Meter —Provides a door-mounted elapsed run time meter.	Control
L1	POWER ON, RUN and FAULT Pilot Lights —Provide a white POWER ON light that indicates power to the enclosed cabinet, a green RUN light that indicates the drive is running and a red FAULT light that indicates a drive fault has occurred.	Light
L2	Bypass Pilot Lights for RA and RB Bypass Options —A green MOTOR ON INVERTER light indicates when the motor is running in inverter mode and an amber MOTOR ON BYPASS light indicates when the motor is running in bypass mode. The lights are mounted on the enclosure door, above the switches.	Add. bypass
LA	Green RUN Light (22 mm) —Provides a green RUN light that indicates the drive is running.	Light
LD	Green STOP Light (22 mm) —Provides a green STOP light that indicates the drive is stopped.	Light
LE	Red RUN Pilot Light (22 mm) —Provides a red RUN pilot light that indicates the drive is running.	Light
LF	Red STOP Light (22 mm) —Provides a red STOP light that indicates the drive is stopped.	Light
LJ	White POWER ON Light (22 mm) —Provides a white POWER ON light that indicates power to the enclosed cabinet.	Light
LU	Misc. Light (22 mm) —Provides a misc. “user defined” pilot light. User to define light function and color.	Light
P1	Input Circuit Breaker —Provides a means of short-circuit protection for the power cables between it and the SVX9000, and protection from high-level ground faults on the power cable. Allows a convenient means of disconnecting the SVX9000 from the line and the operating mechanism can be padlocked in the OFF position. This is factory mounted in the enclosure.	Input
P3	Input Line Fuses Rated to 200 kAIC —Provides high-level fault protection of the SVX9000 input power circuit from the load side of the fuses to the input side of the power transistors. This option consists of three 200 kA fuses, which are factory mounted in the enclosure.	Input
P8	SPD (50 kA per Phase) —Provides a surge protection device (SPD) connected to the line side terminals and is designed to clip line side transients. Rated for 50,000A.	Input
PA	SPD (100 kA per Phase) —Provides a surge protection device (SPD) connected to the line side terminals and is designed to clip line side transients. Rated for 100,000A.	Input
PE	Output Contactor —Provides a means for positive disconnection of the drive output from the motor terminals. The contactor coil is controlled by the drive’s run or permissive logic. NC and NO auxiliary contacts rated at 10A, 600 Vac are provided for customer use. Bypass options RB and RA include an output contactor as standard. This option includes a low VA 115 Vac fused control power transformer and is factory mounted in the enclosure.	Output
PF	Output Filter (100–300 ft) —Used to reduce the transient voltage (DV/DT) at the motor terminals. The output filter is recommended for cable lengths exceeding 100 ft (30m) with a drive of 3 hp and above, for cable lengths of 33 ft (10m) with a drive of 2 hp and below, or for a drive rated at 525–690V. This option is mounted in the enclosure, and may be used in conjunction with a brake chopper circuit.	Output
PG	MotoRX (300–600 ft) 1000 V/μS DV/DT Filter —Used to reduce transient voltage (DV/DT) and peak voltages at the motor terminals. This option is comprised of a 0.5% line reactor, followed by capacitive filtering and an energy recovery/clamping circuit. Unlike the output filter (See option PF), the MotoRx recovers most of the energy from the voltage peaks, resulting in a lower voltage drop to the motor, and therefore conserving power. This option is used when the distance between a single motor and the drive is 300–600 ft (91–183m). <i>This option can not be used with the brake chopper circuit. The output filter (option PF) should be investigated as an alternative.</i>	Output
PH	Single Overload Relay —Uses a bimetallic overload relay to provide additional overload current protection to the motor on configurations without bypass options. It is included with the bypass configurations for overload current protection in the bypass mode. The overload relay is mounted within the enclosure, and is manually resettable. Heater pack included.	Output
PI	Dual Overload Relays —This option is recommended when a single drive is operating two motors and overload current protection is needed for each of the motors. The standard configuration includes two bimetallic overload relays, each sized to protect a motor with 50% of the drive hp rating. For example, a 100 hp drive would include two overload relays sized to protect two 50 hp motors. The relays are mounted within the enclosure, and are manually resettable. Heater packs not included.	Output
PN	Dual Overloads for Bypass —This option is recommended when a single drive is operating two motors in the bypass mode and overload current protection is needed for each of the motors. The standard configuration includes two bimetallic overload relays, each sized to protect a motor with 50% of the drive hp rating. For example, a 100 hp drive would include two overload relays sized to protect two 50 hp motors. The relays are mounted within the enclosure, and are manually resettable.	Add. bypass

For availability, see Product Selection for base drive voltage required.

Available Control/Communications Options, continued

Option	Description	Option Type
RA	Manual HOA Bypass Controller —The manual HAND/OFF/AUTO (HOA)—3-contactor—bypass option provides a means of bypassing the SVX9000, allowing the AC motor to be operated at full speed directly from the AC supply line. This option consists of an input disconnect, a fused control power transformer, and a full voltage bypass starter with a door mounted HOA selector switch and an INVERTER/BYPASS switch. The HOA switch provides the ability to start and stop the drive in the inverter mode. For applications up to 100 hp, a Freedom Series IEC input contactor, a Freedom Series IEC output contactor, and a Freedom Series IEC starter with a bimetallic overload relay is included. For applications above 100 hp, an Advantage input contactor, an Advantage output contactor and an Advantage starter with electronic overload protection is included. The contactors are mechanically and electrically interlocked.	Bypass
RB	Manual IOB Bypass Controller —The manual INVERTER/OFF/BYPASS (IOB)—3-contactor—bypass option provides a means of bypassing the SVX9000, allowing the AC motor to be operated at full speed directly from the AC supply line. This option consists of an input disconnect, a fused control power transformer, and a full voltage bypass starter with a door mounted IOB selector switch. For applications up to 100 hp, a Freedom Series IEC input contactor, a Freedom Series IEC output contactor, and a Freedom Series IEC starter with a bimetallic overload relay is included. For applications above 100 hp, an Advantage input contactor, an Advantage output contactor and an Advantage starter with electronic overload protection is included. The contactors are mechanically and electrically interlocked.	Bypass
RC	Auto Transfer HOA Bypass Controller —The manual HAND/OFF/AUTO (HOA)—3-contactor—bypass option provides a means of bypassing the SVX9000, allowing the AC motor to be operated at full speed directly from the AC supply line. The circuitry provides an automatic transfer of the load to “across the line” operation after a drive trip. This option consists of an input disconnect, a fused control power transformer, and a full voltage bypass starter with a door mounted HOA selector switch and an INVERTER/BYPASS switch. The HOA switch provides the ability to start and stop the drive in either mode. For applications up to 100 hp, a Freedom Series IEC input contactor, a Freedom Series IEC output contactor, and a Freedom Series IEC starter with a bimetallic overload relay is included. For applications above 100 hp, an Advantage input contactor, an Advantage output contactor and an Advantage starter with electronic overload protection is included. The contactors are mechanically and electrically interlocked. Door-mounted pilot lights are provided which indicate bypass or inverter operation. A green light indicates when the motor is running in inverter mode and an amber light indicates when the motor is running in bypass mode. WARNING: The motor may restart when the overcurrent relay is reset when operating in bypass, unless the IOB selector switch is turned to the OFF position.	Bypass
RD	Auto Transfer IOB Bypass Controller —The auto INVERTER/OFF/BYPASS (IOB)—3-contactor—bypass option provides a means of bypassing the SVX9000, allowing the AC motor to be operated at full speed directly from the AC supply line. The circuitry provides an automatic transfer of the load to “across the line” operation after a drive trip. This option consists of an input disconnect, a fused control power transformer, and a full voltage bypass starter with a door mounted IOB selector switch. For applications up to 100 hp, a Freedom Series IEC input contactor, a Freedom Series IEC output contactor, and a Freedom Series IEC starter with a bimetallic overload relay is included. For applications above 100 hp, an Advantage input contactor, an Advantage output contactor and an Advantage starter with electronic overload protection is included. The contactors are mechanically and electrically interlocked. Door-mounted pilot lights are provided which indicate bypass or inverter operation. A green light indicates when the motor is running in inverter mode and an amber light indicates when the motor is running in bypass mode. WARNING: The motor may restart when the overcurrent relay is reset when operating in bypass, unless the IOB selector switch is turned to the OFF position.	Bypass
S5	Floor Stand 22 in —Converts a Size 1 or 2, normally wall mounted enclosure to a floor standing enclosure with a height of 22 in (558.8 mm).	Enclosure
S6	Floor Stand 12 in —Converts a Size 2, normally wall mounted enclosure to a floor standing enclosure with a height of 12 in (304.8 mm).	Enclosure
S7	10 in Expansion —In a Size 5 enclosure, the extension allows for bottom cable entry and additional space for customer mounted components. NOTE: Enclosure expansion rated NEMA Type 1/IP21 only.	Enclosure
S8	20 in Expansion —In a Size 5 enclosure, the extension allows for bottom cable entry and additional space for customer mounted components. When the output filter (option PF) is selected for a drive using a Size 5 enclosure, this expansion box is required and included in the option pricing. Enclosure expansion rated NEMA Type 1/IP21 only.	Enclosure
S9	Space Heater —Prevents condensation from forming in the enclosure when the drive is inactive or in storage. Includes a thermostat for variable temperature control. A 200W heater is installed in enclosures 0 and 1, and a 400W heater is installed in enclosures 2–5.	Enclosure
SA	Space Heater with CPT —Prevents condensation from forming in the enclosure when the drive is inactive or in storage. Includes a thermostat for variable temperature control. A 200W heater is installed in enclosures 0 and 1, and a 400W heater is installed in enclosures 2–5. Includes a 115V supply to power heater.	Enclosure

Enclosed Drive Options

Brake Chopper Options

The brake chopper circuit option is used for applications that require dynamic braking. Dynamic braking resistors are not included with drive purchase. Consult **Page V6-T2-58** for dynamic braking resistors which are supplied separately. Resistors are not UL Listed.

For brake chopper circuit selection and adder—NEMA Type 1/IP21, NEMA Type 12/IP54, consult the factory

SVX Conversion Kit

Frame 4–7 ^①

Frame Size	Enclosure Size	Delivery Code	Catalog Number
FR4	0	FB10	OPTCON-SVXFR4-SZ00
	1		OPTCON-SVXFR4-SZ01
FR5	0	FB10	OPTCON-SVXFR5-SZ00
	1		OPTCON-SVXFR5-SZ01
FR6	1	FB10	OPTCON-SVXFR6-SZ01
	2		OPTCON-SVXFR6-SZ02
FR7	2	FB10	OPTCON-SVXFR7-SZ02

Note

^① The kit consists of a flange kit, adapter plate(s), hardware, remote keypad kit and SVX9000 decal.

Technical Data and Specifications

2

9000X Enclosed Drives

Description	NEMA Type 1/IP21 or NEMA Type 12/IP54 Specification
Primary Design Features	
45–66 Hz input frequency	Standard
Output: AC volts maximum	Input voltage base
Output frequency range	0–320 Hz
Initial output current (I_H)	250% for 2 seconds
Overload (1 minute (I_H/I_L))	150%/110%
Enclosure space heater	Optional
Oversize enclosure	Standard
Output contactor	Optional
Bypass motor starter	Optional
Listings	UL, cUL
Protection Features	
Incoming line fuses	Optional
AC input circuit disconnect	Optional
Line reactors (3%)	Standard
Phase rotation insensitive	Standard
EMI filter	Standard
Input phase loss protection	Standard
Input overvoltage protection	Standard
Line surge protection	Optional
Output short-circuit protection	Standard
Output ground fault protection	Standard
Output phase protection	Standard
Overtemperature protection	Standard
DC overvoltage protection	Standard
Drive overload protection	Standard
Motor overload protection	Standard
Programmer software	Optional
Local/remote keypad	Standard
Keypad lockout	Standard
Fault alarm output	Standard
Built-in diagnostics	Standard

Description	NEMA Type 1/IP21 or NEMA Type 12/IP54 Specification
Input/Output Interface Features	
Setup adjustment provisions	
Remote keypad/display	Standard
Personal computer	Standard
Operator control provisions	
Drive mounted keypad/display	Standard
Remote keypad/display	Standard
Conventional control elements	Standard
Serial communications	Optional
115 Vac control circuit	Optional
Speed setting inputs	
Keypad	Standard
0–10 Vdc potentiometer/voltage signal	Standard
4–20 mA Isolated	Configurable
4–20 mA Differential	Configurable
Analog outputs	
Speed/frequency	Standard
Torque/load/current	Programmable
Motor voltage	Programmable
Kilowatts	Programmable
0–10 Vdc signals	Configurable w/jumpers
4–20 mA DC signals	Standard
Isolated signals	Optional
Discrete outputs	
Fault alarm	Standard
Drive running	Standard
Drive at set speed	Programmable
Optional parameters	14
Dry contacts	1 (2 relays Form C)
Open collector outputs	1
Additional discrete outputs	Optional
Communications	
RS-232	Standard
RS-422/485	Optional
DeviceNet™	Optional
Modbus RTU	Optional
CANopen (slave)	Optional
PROFIBUS-DP	Optional
Lonworks®	Optional
Johnson Controls Metasys™ N2	Optional
EtherNet/IP	Optional
Modbus TCP	Optional
BACnet	Optional

9000X Enclosed Drives, continued

Description	NEMA Type 1/IP21 or NEMA Type 12/IP54 Specification
Performance Features	
Sensorless vector control	Standard
Volts/hertz control	Standard
IR and slip compensation	Standard
Electronic reversing	Standard
Dynamic braking	Optional ^①
DC braking	Standard
PID setpoint controller	Programmable
Critical speed lockout	Standard
Current (torque) limit	Standard
Adjustable acceleration/deceleration	Standard
Linear or S curve accel/decel	Standard
Jog at preset speed	Standard
Thread/preset speeds	7 Standard, 15 Optional
Automatic restart	Selectable
Coasting motor start	Standard
Coast or ramp stop selection	Standard
Elapsed time meter	Optional
Carrier frequency adjustment	1–16 kHz
Standard Conditions for Application and Service	
Operating ambient temperature	0 to 40°C
Storage temperature	–40 to 60°C
Humidity (maximum), non-condensing	95%
Altitude (maximum without derate)	3300 ft (1000m)
Line voltage variation	+10/–15%
Line frequency variation	45–66 Hz
Efficiency	>96%
Power factor (displacement)	>0.94

Standard I/O Specifications

Description	Specification
Six–digital input programmable	24V: "0" ≤10V, "1" ≥18V, R _i >5 kohms
Two–analog input configurable w/jumpers	Voltage: 0–±10V, R _i >200 kohms Current: 0 (4)–20 mA, R _i = 250 ohms
Two–digital output programmable	Form C relays 250 Vac 30 Vdc 2 amp resistive
One–analog output programmable configurable w/jumper	0–20 mA, R _L max. 500 ohms 10 bits ±2%
One digital output programmable	Open collector 48 Vdc 50 mA

I/O Specifications for Control/Communication Options

Description	Specification
Analog voltage, input	0–±10V, R _i ≥200 kohms
Analog current, input	0 (4)–20 mA, R _i = 250 ohms
Digital input	24V: "0" ≤10V, "1" ≥18V, R _i >5 kohms
Auxiliary voltage	24V (±20%), max. 50 mA
Reference voltage	10V ±3%, max. 10 mA
Analog current, output	0 (4)–20 mA, R _L = 500 kohms resolution 10 bit, accuracy ≤±2%
Analog voltage, output	0 (2)–10V, R _L ≥1 kohms, resolution 10 bit, accuracy ≤±2%
Relay output	
Maximum switching voltage	300 Vdc, 250 Vac
Maximum switching load	8A/24 Vdc, 0.4A/300 Vdc, 2 kVA/250 Vac
Maximum continuous load	2A rms
Thermistor input	R _{trip} = 4.7 kohms
Encoder input	24V: "0" ≤10V, "1" ≥18V, R _i = 2.2 kohms 5V: "0" ≤2V, "1" ≥3V, R _i = 330 ohms

Note

^① Some horsepower units include dynamic braking chopper as standard—refer to individual drive sections.

2.5

Adjustable Frequency Drives

SVX9000 Drives

Dimensions

Approximate Dimensions in Inches (mm)

2

9000X Enclosed Drives

Size 0

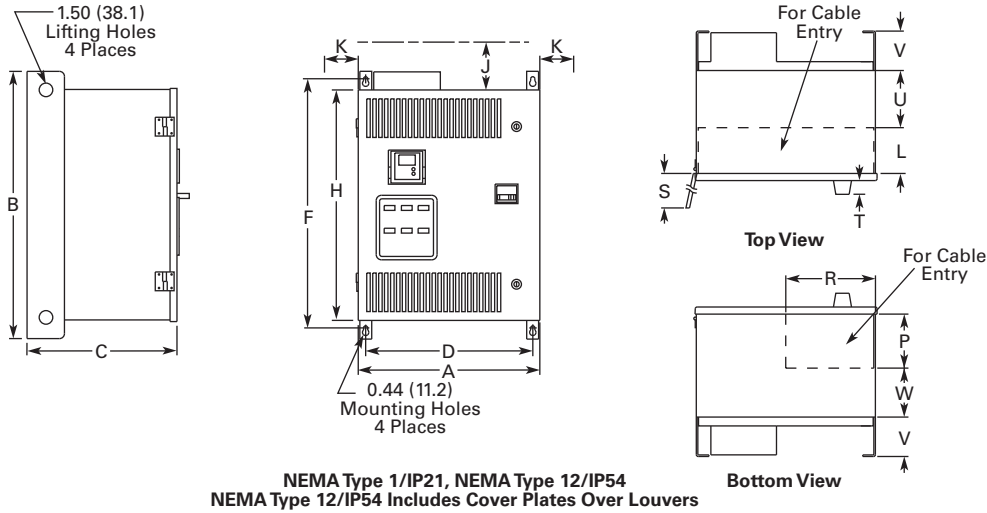

For reference only, dimensions are subject to change.

Wide A	High B	Deep C	Mounting D D1		E	E1	F	G	G1	Door Height H	Min. Air Space J K	
19.9 (504)	29.0 (737)	16.4 (416)	18.3 (465)	—	—	—	27.4 (695)	—	—	25.4 (644)	4.0 (102)	3.0 (76)
Cable Entry L	M	N	P	R	Door Clearance S		CB Handle T U		V	W	Max. Approx. Shipping Weight Lbs (kg)	
5.0 (127)	—	—	6.0 (152)	9.6 (245)	26.4 (669)		1.5 (38) 6.3 (160)		4.3 (108)	5.3 (134)	200 (91)	

Approximate Dimensions in Inches (mm)

Size 1

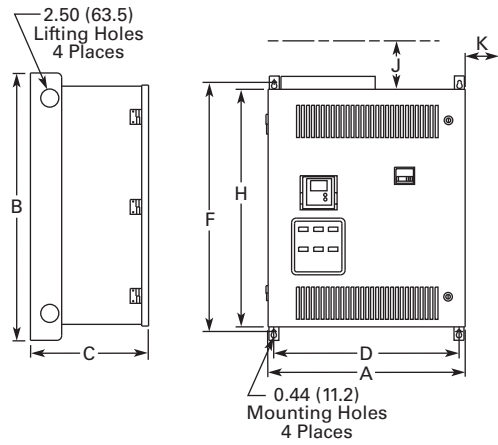

NEMA Type 1/IP21, NEMA Type 12/IP54
NEMA Type 12/IP54 Includes Cover Plates Over Louvers

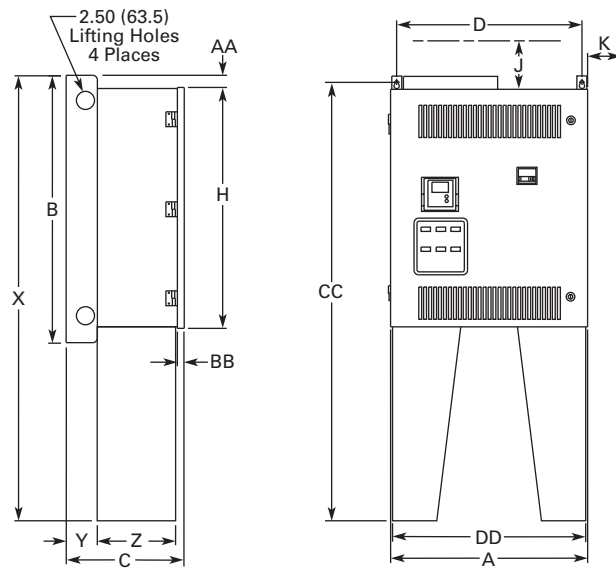

NEMA Type 1/IP21, NEMA Type 12/IP54
with Floor Stand

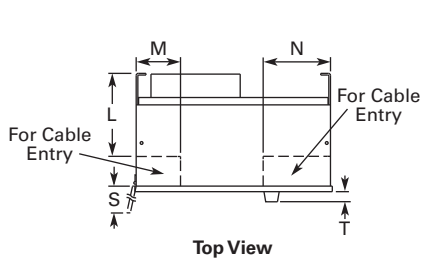

Top View

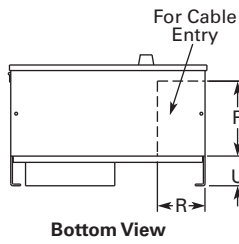

Bottom View

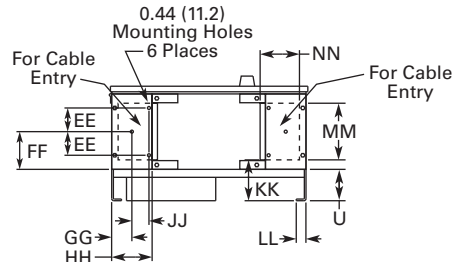

Bottom View
NEMA Type 1/IP21, NEMA Type 12/IP54
with Floor Stand

For reference only, dimensions are subject to change.

Wide	High	Deep	Mounting						Door Height	Min. Air Space		
A	B	C	D	D1	E	E1	F	G	G1	H	J	K
26.4 (669)	36 (914)	16.3 (414)	24.8 (630)	—	—	—	34.0 (864)	—	—	32.4 (822)	4.0 (102)	3.0 (76)

Cable Entry					Door Clearance	CB Handle						Max. Approx. Shipping Weight	
L	M	N	P	R	S	T	U	V	W	XX	YY	ZZ	Lbs (kg)
11.0 (279)	6.0 (152)	9.0 (229)	10.0 (254)	6.5 (165)	26.4 (669)	1.5 (38)	4.3 (108)	—	—	—	—	—	230 (104)

Floor Stand																					
X	Y	Z	AA	BB	CC	DD	EE	FF	GG	HH	JJ	KK	LL	MM	NN	PP	RR	SS	TT	UU	VV
56.0 (1422)	4.3 (108)	11.1 (281)	1.8 (46)	0.8 (19)	55.2 (1402)	26.0 (660)	3.5 (90)	5.5 (141)	3.0 (76)	6.0 (152)	2.0 (51)	5.4 (136)	1.1 (28)	8.8 (224)	5.4 (137)	—	—	—	—	—	—

2.5

Adjustable Frequency Drives

SVX9000 Drives

Approximate Dimensions in Inches (mm)

Size 2

2

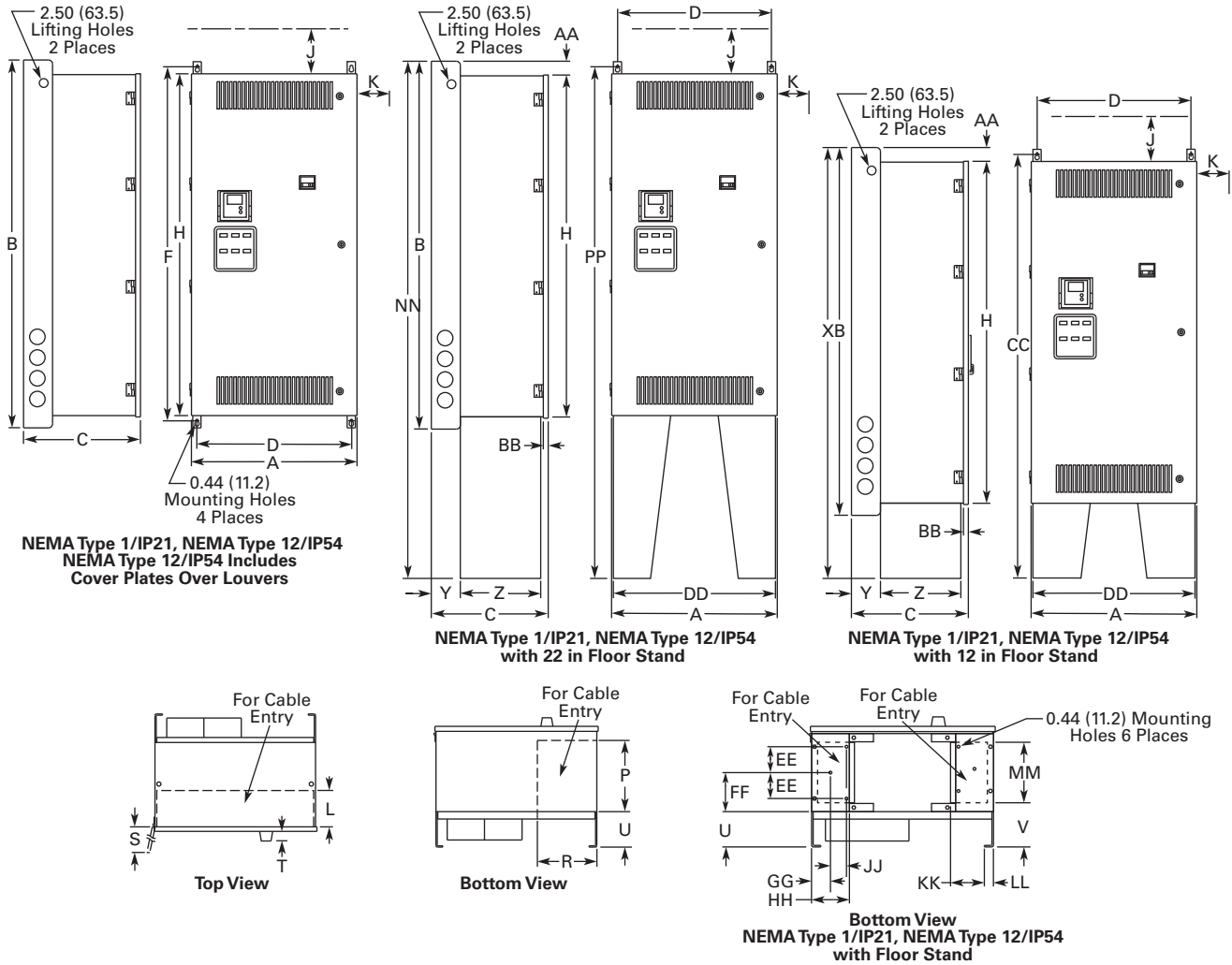

For reference only, dimensions are subject to change.

Wide	High	Deep	Mounting						Door Height	Min. Air Space		
A	B	C	D	D1	E	E1	F	G	G1	H	J	K
26.4 (669)	59.0 (1499)	19.4 (492)	24.8 (630)	—	—	—	57.0 (1448)	—	—	55.4 (1406)	4.0 (102)	3.0 (76)

Cable Entry				Door Clearance		CB Handle					Max. Approx. Shipping Weight
L	M	N	P	R	S	T	U	V	W	SS	Lbs (kg)
5.9 (149)	—	—	12.4 (315)	9.5 (241)	26.4 (669)	1.5 (38)	4.8 (121)	5.9 (151)	—	—	380 (173)

Floor Stand																					
X	Y	Z	AA	BB	CC	DD	EE	FF	GG	HH	JJ	KK	LL	MM	NN	PP	RR	SS	TT	UU	VV
69.0 (1753)	4.8 (121)	13.6 (344)	1.8 (46)	0.8 (19)	68.2 (1732)	26.0 (660)	4.8 (121)	6.8 (172)	3.0 (76)	6.0 (152)	2.0 (51)	5.0 (127)	1.1 (28)	11.3 (288)	79.0 (2007)	78.2 (1986)	—	—	—	—	—

Approximate Dimensions in Inches (mm)

Size 3

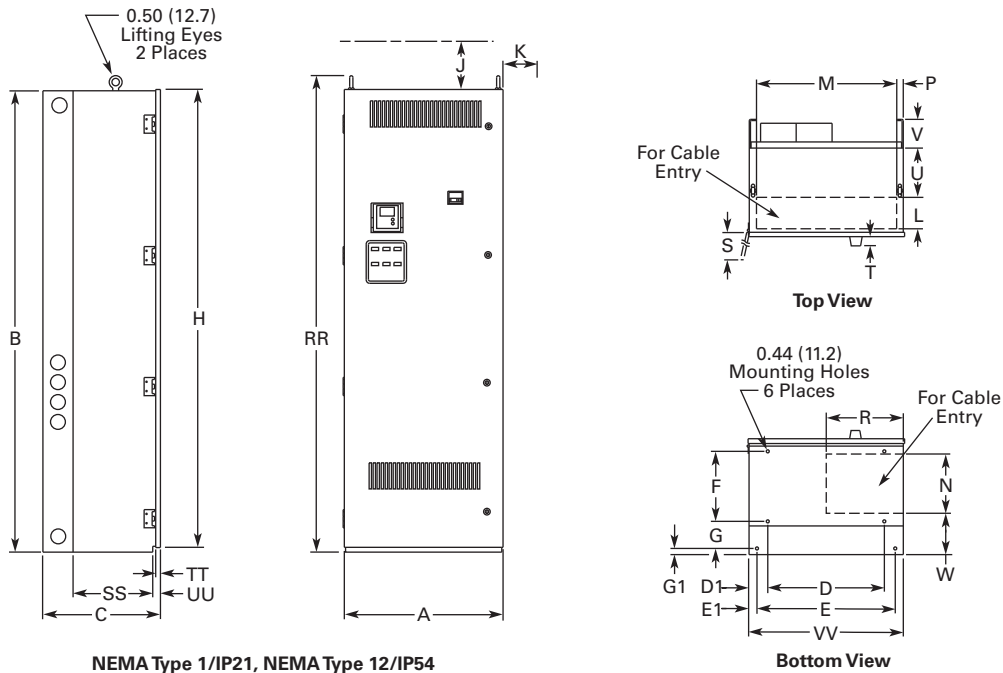

For reference only, dimensions are subject to change.

Wide	High	Deep	Mounting							Door Height	Min. Air Space	
A	B	C	D	D1	E	E1	F	G	G1	H	J	K
26.4 (671)	77.0 (1956)	19.4 (493)	19.5 (495)	3.3 (83)	23.0 (584)	1.5 (38)	11.7 (298)	5.5 (140)	0.9 (24)	76.4 (1939)	4.0 (102)	3.0 (76)

Cable Entry		Door Clearance				CB Handle									Max. Approx. Shipping Weight
L	M	N	P	R	S	T	U	V	W	RR	SS	TT	UU	VV	Lbs (kg)
5.3 (133)	23.4 (594)	10.0 (254)	1.3 (32)	12.9 (328)	26.4 (669)	1.5 (38)	8.0 (203)	4.8 (121)	6.8 (173)	79.5 (2018)	13.40 (340)	0.8 (19)	1.3 (32)	26.0 (660)	690 (313)

2.5

Adjustable Frequency Drives

SVX9000 Drives

Approximate Dimensions in Inches (mm)

Size 4

2

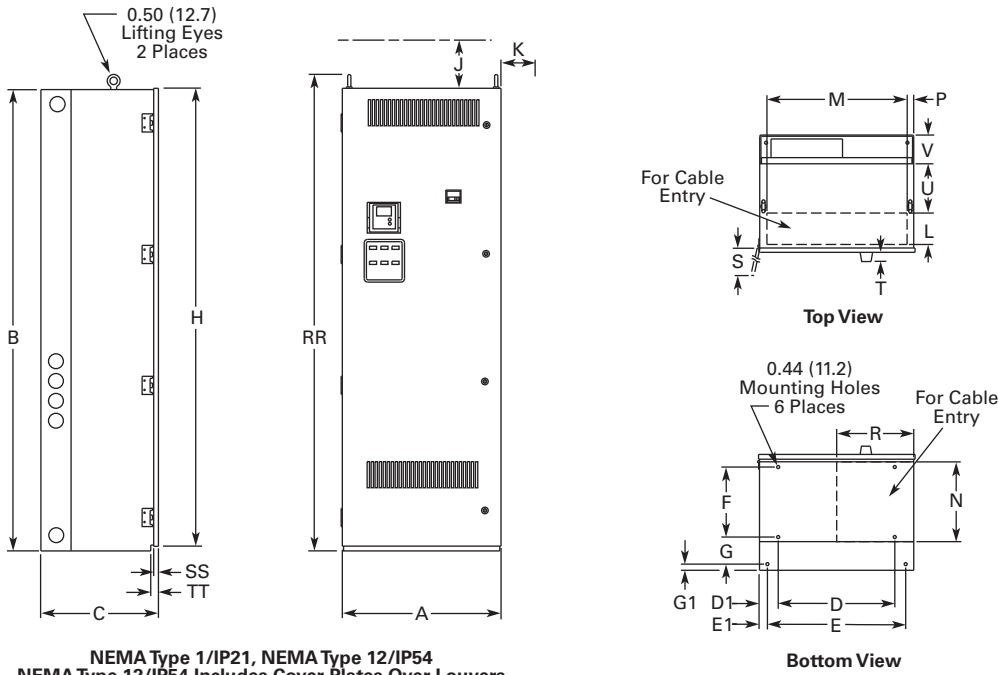

For reference only, dimensions are subject to change.

Wide A	High B	Deep C	Mounting D D1		E	E1	F	G	G1	Door Height H	Min. Air Space J K	
26.4 (671)	90.0 (2286)	19.4 (493)	19.5 (495)	3.3 (83)	23.0 (584)	1.5 (38)	11.7 (298)	5.5 (140)	0.9 (24)	89.4 (2270)	4.0 (102)	3.0 (76)

Cable Entry L M		N	P	R	Door Clearance S	CB Handle T U		V	W	RR	SS	TT	UU	VV	Max. Approx. Shipping Weight Lbs (kg)
5.3 (133)	23.4 (594)	13.8 (351)	1.0 (25)	11.2 (286)	26.4 (669)	1.5 (38)	8.0 (204)	4.8 (121)	—	92.5 (2349)	0.8 (19)	1.3 (32)	—	—	825 (375)

Approximate Dimensions in Inches (mm)

Size 5

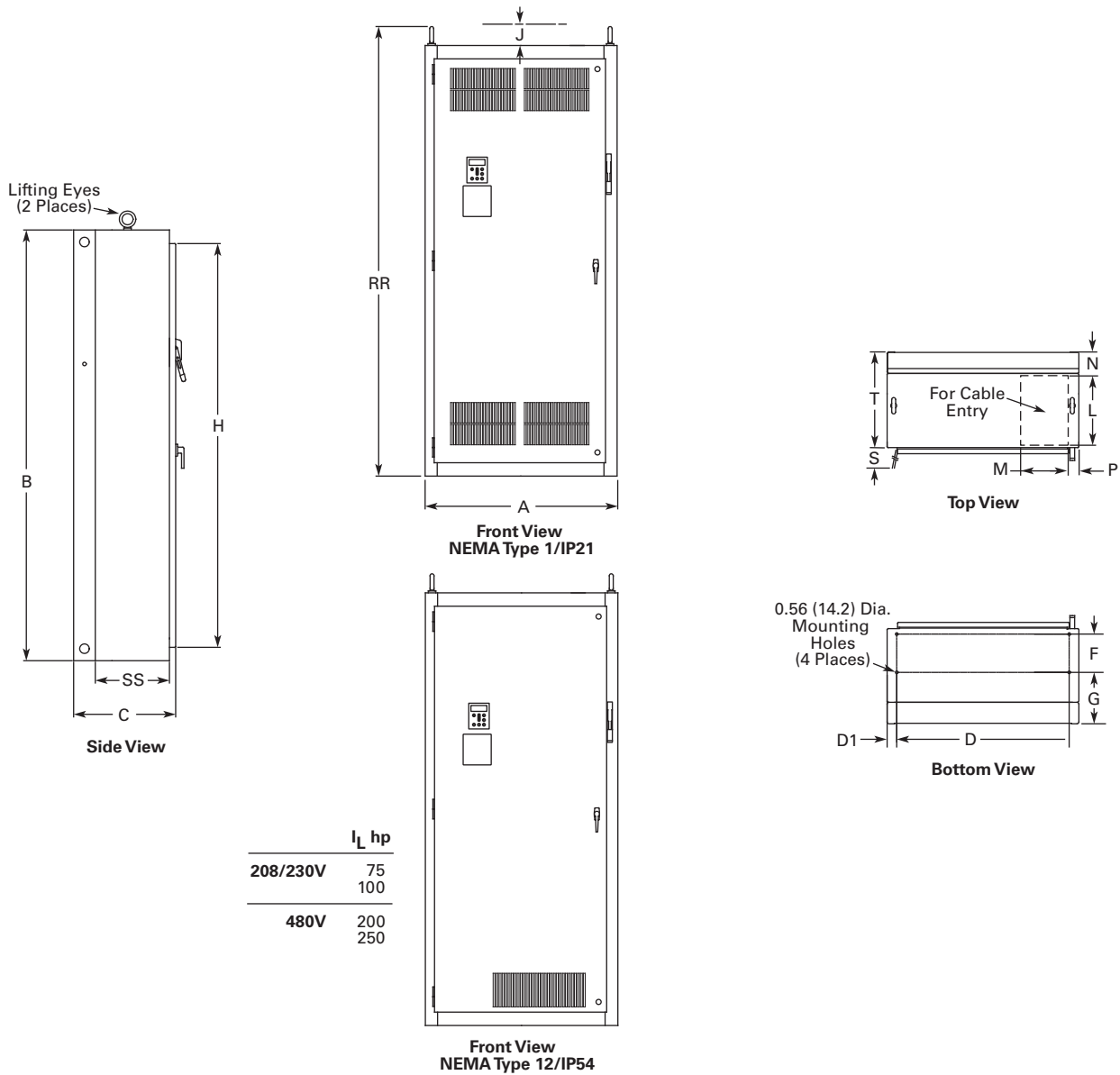

For reference only, dimensions are subject to change.

Wide	High	Deep	Mounting							Door Height	Min. Air Space	
A	B	C	D	D1	E	E1	F	G	G1	H	J	K
40.0 (1016)	90.0 (2286)	21.3 (541)	36.0 (914)	2.0 (51)	—	—	8.0 (203)	10.8 (273)	—	84.4 (2143)	4.0 (102)	—

Cable Entry			Door Clearance										Max. Approx. Shipping Weight		
L	M	N	P	R	S	T	U	V	W	RR	SS	TT	UU	VV	Lbs (kg)
15.0 (381)	10.0 (254)	4.8 (122)	2.0 (51)	—	36.3 (921)	20.0 (508)	—	—	—	94.0 (2387)	15.5 (394)	—	—	—	1275 (579)

2.5

Adjustable Frequency Drives

SVX9000 Drives

Approximate Dimensions in Inches (mm)

Size 5-1P

2

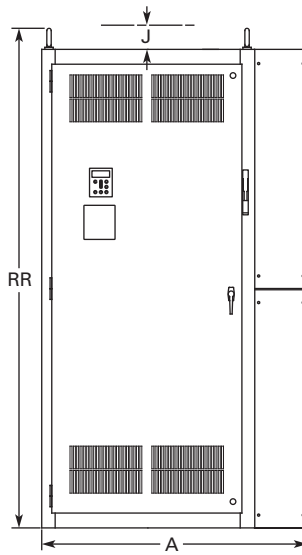
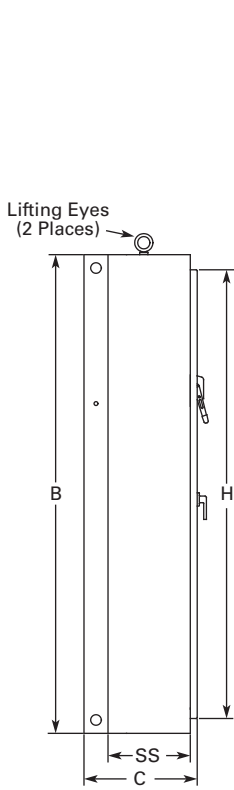

Front View
NEMA Type 1/IP21

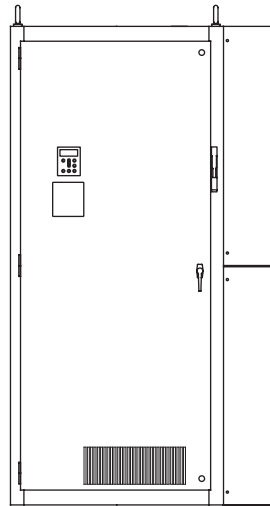

Front View
NEMA Type 12/IP54

	I_L hp
208/230V	75
	100
480V	200
	250

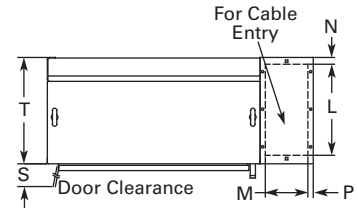

Top View

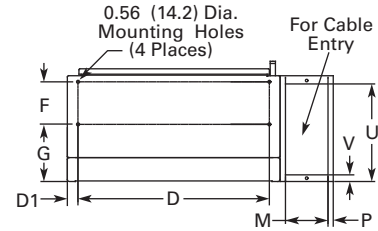

Bottom View

For reference only, dimensions are subject to change.

Wide	High	Deep	Mounting							Door Height	Min. Air Space	
A	B	C	D	D1	E	E1	F	G	G1	H	J	K
50.0 (1270)	90.0 (2286)	21.3 (541)	36.0 (914)	2.0 (51)	—	—	8.0 (203)	10.8 (273)	—	84.4 (2143)	4.0 (102)	—

Cable Entry		Door Clearance										Max. Approx. Shipping Weight			
L	M	N	P	R	S	T	U	V	W	RR	SS	TT	UU	VV	Lbs (kg)
17.1 (435)	8.0 (203)	1.3 (33)	1.0 (25)	—	36.3 (921)	20.0 (508)	18.4 (466)	1.3 (32)	—	94.0 (2387)	15.5 (394)	—	—	—	1375 (624)

Approximate Dimensions in Inches (mm)

Size 5-2P

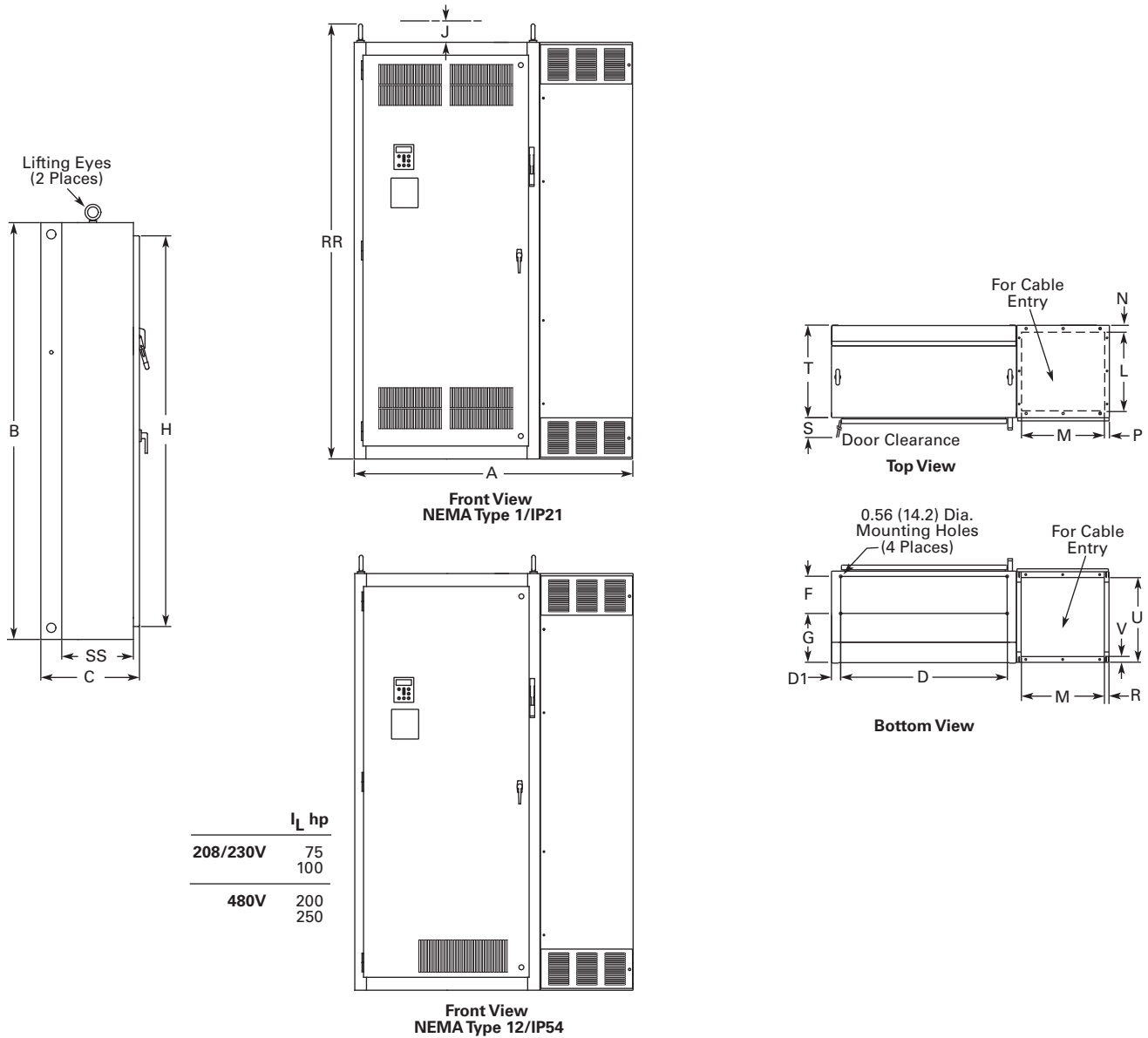

For reference only, dimensions are subject to change.

Wide A	High B	Deep C	Mounting D D1		E	E1	F	G	G1	Door Height H	Min. Air Space J K					
Enclosure Size 5-2P																
60.0 (1524)	90.0 (2286)	21.3 (541)	36.0 (914)	2.0 (51)	—	—	8.0 (203)	10.8 (273)	—	84.4 (2143)	4.0 (102)	—				
Cable Entry L	M	N	P	R	Door Clearance S		T	U	V	W	RR	SS	TT	UU	VV	Max. Approx. Shipping Weight Lbs (kg)
17.0 (432)	18.0 (457)	1.5 (38)	1.0 (25)	0.9 (23)	36.3 (921)	20.0 (508)	18.4 (466)	1.3 (32)	—	—	94.0 (2387)	15.5 (394)	—	—	—	1585 (720)

2.5

Adjustable Frequency Drives

SVX9000 Drives

Approximate Dimensions in Inches (mm)

Size 6

2

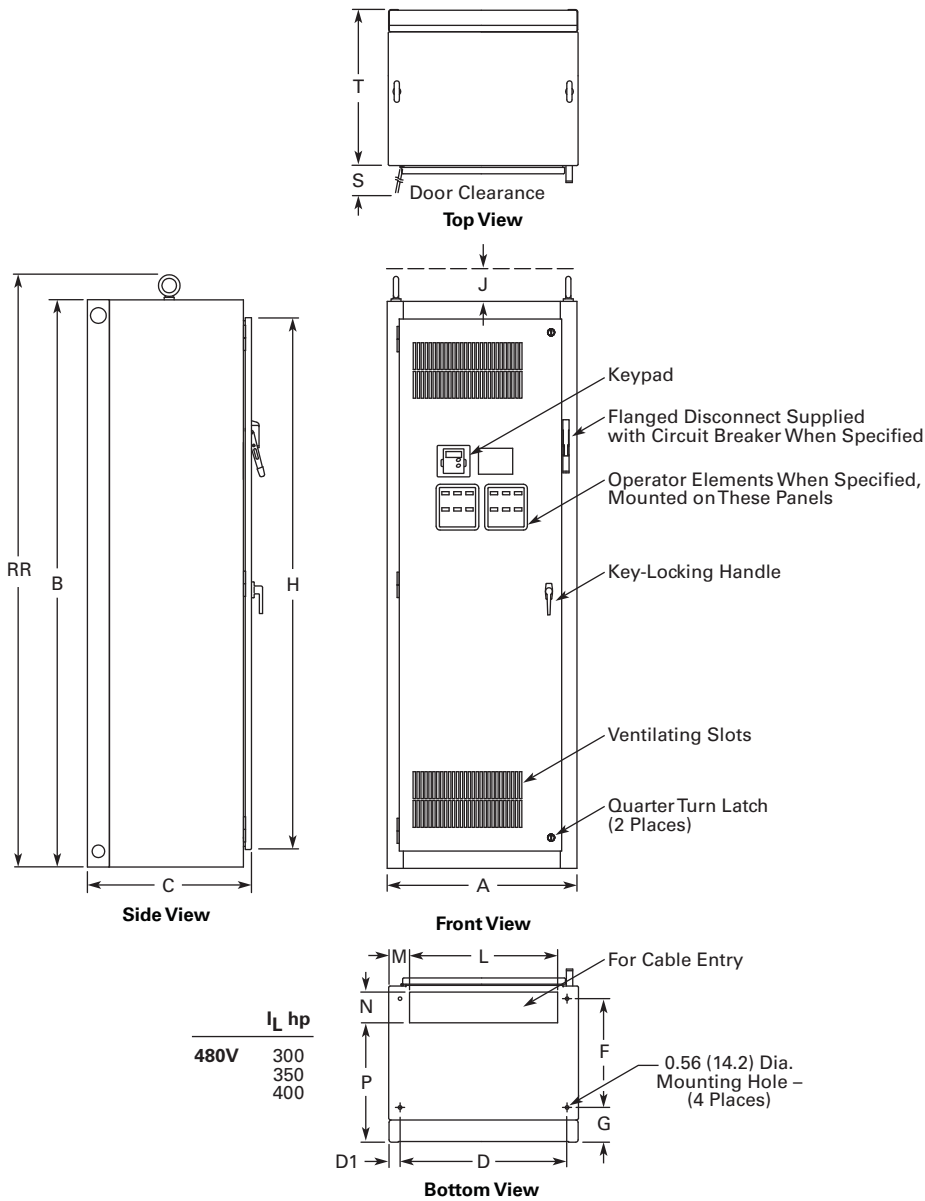

For reference only, dimensions are subject to change. See **Page V6-T2-92**, notes 3 and 5 for enclosure and option selection.

Wide	High	Deep	Mounting							Door Height	Min. Air Space	
A	B	C	D	D1	E	E1	F	G	G1	H	J	K
30.0 (762)	90.0 (2286)	26.0 (660)	26.5 (673)	1.8 (46)	—	—	17.3 (438)	5.5 (140)	—	84.4 (2143)	4.0 (102)	—

Cable Entry		Door Clearance															Max. Approx. Shipping Weight
L	M	N	P	R	S	T	U	V	W	RR	SS	TT	UU	VV	Lbs (kg)		
23.5 (597)	3.3 (84)	4.5 (114)	19.3 (490)	—	26.2 (667)	24.8 (629)	—	—	—	93.9 (2386)	—	—	—	—	1500 (681)		

Approximate Dimensions in Inches (mm)

Size 8

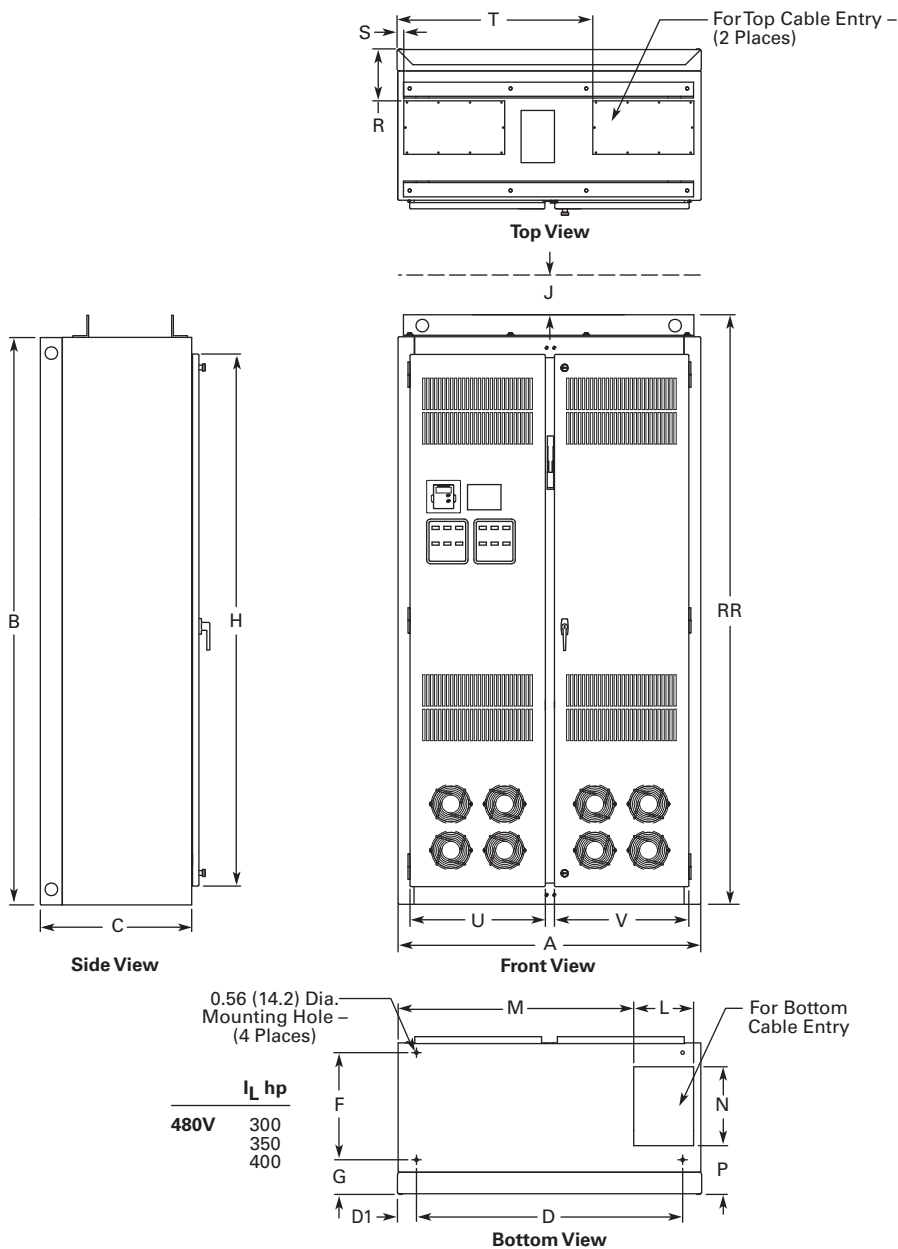

For reference only, dimensions are subject to change. See **Page V6-T2-92**, notes 3 and 5 for enclosure and option selection.

Wide A	High B	Deep C	Mounting D D1		E	E1	F	G	G1	Door Height H	Min. Air Space J K	
48.0 (1219)	90.0 (2286)	24.0 (610)	42.2 (1072)	3.0 (77)	—	—	—	5.5 (139)	—	84.4 (2143)	4.0 (102)	—

Cable Entry															Max. Approx. Shipping Weight Lbs (kg)
L	M	N	P	R	S	T	U	V	W	RR	SS	TT	UU	VV	
9.5 (241)	37.5 (952)	12.5 (318)	7.7 (196)	8.3 (210)	1.3 (32)	31.0 (787)	21.5 (545)	21.3 (541)	—	93.5 (2375)	—	—	—	—	2000 (908)

2.5

Adjustable Frequency Drives

SVX9000 Drives

Approximate Dimensions in Inches (mm)

Size 9

2

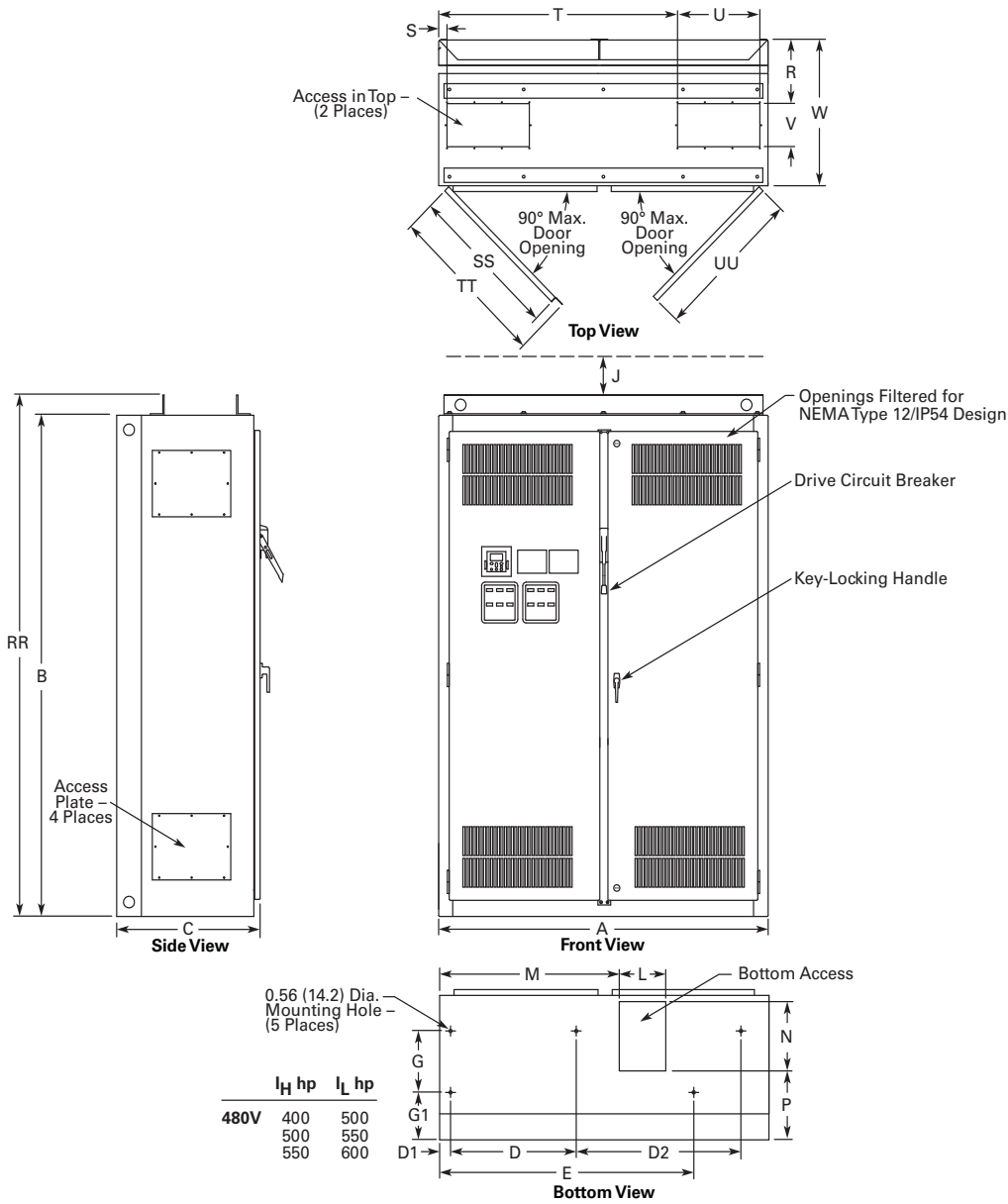

For reference only, dimensions are subject to change. See **Page V6-T2-92**, notes 3 and 5 for enclosure and option selection.

Wide	High	Deep	Mounting								Door Height	Min. Air Space	
A	B	C	D	D1	E	E1	F	G	G1	H	J	K	
60.0 (1524)	90.0 (2286)	260.1 (664)	22.9 (582)	2.0 (51)	30.0 (762)	44.3 (1125)	10.6 (270)	10.6 (270)	8.2 (208)	—	4.0 (102)	—	

Cable Entry													Max. Approx. Shipping Weight Lbs (kg)		
L	M	N	P	R	S	T	U	V	W	RR	SS	TT		UU	VV
8.5 (216)	32.7 (831)	12.0 (305)	11.9 (303)	9.8 (249)	1.5 (38)	43.5 (1105)	15.0 (381)	7.5 (191)	25.0 (635)	93.5 (2375)	27.4 (696)	290.1 (738)	270.1 (687)	—	2500 (1135)

SVX9000 VFD Pump Panels



SVX9000 VFD Pump Panels

Product Description

- **Standard Enclosed**—covers a wide range of the most commonly ordered options. Pre-engineering eliminates the lead time normally associated with customer specific options.
- **Modified Standard Enclosed**—applies to specific customer requirements that vary from the Standard Enclosed offering, such as the need for an additional indicating light or minor modifications to drawings. *Consult your Eaton representative for assistance in pricing and lead time.*
- **Custom Engineered**—for those applications with more unique or complex requirements, these are individually engineered to the customer's needs. *Consult your Eaton representative for assistance in pricing and lead time.*

Features

- NEMA Type 12/IP54 or NEMA Type 3R enclosures
- Input voltage: 208V, 230V, 480V and 575V (consult factory)
- Complete range of control, network and power options
- Horsepower range:
 - 208V—3/4 to 100 hp I_H; 1 to 100 hp I_L
 - 230V—3/4 to 100 hp I_H; 1 to 100 hp I_L
 - 480V—1 to 350 hp I_H; 1-1/2 to 400 hp I_L
- Padlockable disconnect
- Single-phase input available

Standards and Certifications

- UL Listed
- cUL Listed

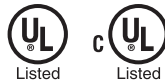

Contents

Description	Page
SVX9000 Drives	V6-T2-48
SVX9000 Enclosed Drives	V6-T2-87
SVX9000 VFD Pump Panels	
Catalog Number Selection	V6-T2-112
Product Selection	V6-T2-113
Options	V6-T2-118
Technical Data and Specifications	V6-T2-121
Wiring Diagrams	V6-T2-123
Dimensions	V6-T2-124

Product Identification

SVX9000 Pump Application

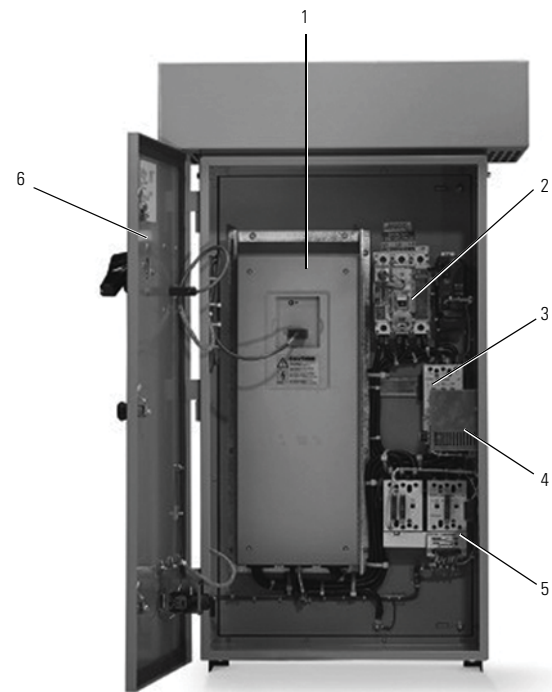

- | | |
|-------------------------------------------------------------|----------------------------------------------|
| 1 SVX9000 variable frequency drive | 4 Space heater Option S9 |
| 2 Input disconnect Option P1 | 5 Bypass contactor Option RA/RB |
| 3 Input contactor (included as standard with bypass option) | 6 Door-mounted keypad (included as standard) |

2.5

Adjustable Frequency Drives

SVX9000 Drives

Catalog Number Selection

SVX9000 Enclosed NEMA Type 12/IP54/3R Drive

2

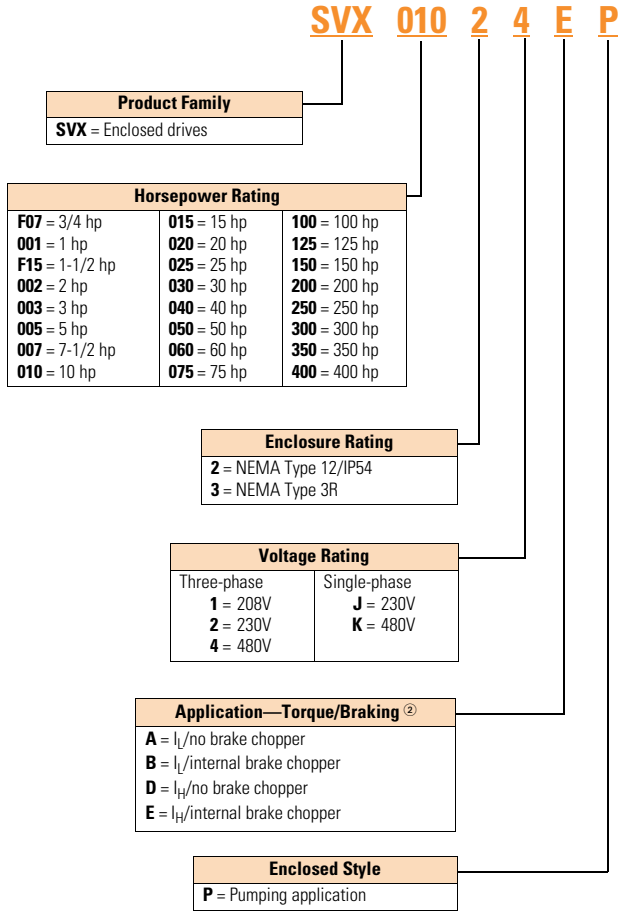

Build Alphabetically and Numerically

Enclosed Options ^{①④⑤}		Type
K1	Door-mounted speed potentiometer ^③	Control
K2	Door-mounted speed potentiometer with HOA selector switch ^③	Control
K5	MANUAL/AUTO reference switch (22 mm)	Control
K6	START and STOP pushbuttons (22 mm)	Control
K9	(2) Factory installed auxiliary contacts	Power
L1	POWER ON, RUN and Fault pilot lights	Light
L2	Bypass pilot lights for RA bypass option ^⑦	Addl. bypass
LD	Green STOP light	Light
LE	Red RUN light	Light
LU	Misc. light (22 mm)	Light
LW	PTT light (22 mm)	Light
P1	Input circuit breaker	Input
P3	Input line fuses (200 kAIC)	Input
P8	SPD (50 kA per phase)	Input
PA	SPD (100 kA per phase)	Input
PE	Output contactor	Output
PF	Output filter	Output
PG	MotoRX (300–600 ft) 1000 V/μS DV/DT filter	Output
RA	Manual HOA bypass controller ^⑦	Bypass
S5	Floor stand 22 in	Enclosure
S9	Space heater w/out CPT	Enclosure
SA	Space heater w/CPT	Enclosure
SB	Socket type control relay	Enclosure
SE	On-delay timer	Enclosure
SF	Off-delay timer	Enclosure

Communication Options ^⑥	
C2	Modbus
C3	PROFIBUS DP
C4	LonWorks
C5	PROFIBUS DP (D9 connector)
C6	CANopen (slave)
C7	DeviceNet
C8	Modbus (D9 type connector)
CA	Johnson Controls N2
CI	Modbus TCP
CJ	BACnet
CQ	EtherNet/IP
D3	RS-232 with D9 connection

Control Options	
B1	6 DI, 1 ext +24 Vdc/EXT +24 Vdc
B2	1 RO (NC-NO), 1 RO (NO), 1 therm
B4	1 AI (mA isolated), 2 AO (mA isolated), 1 ext +24 Vdc/EXT +24 Vdc
B5	3 RO (NO)
B8	1 ext +24 Vdc/EXT +24 Vdc, 3 Pt100
B9	1 RO (NO), 5 DI 42–240 Vac input

Notes

- ① Local/remote keypad is included as the standard control panel.
- ② Brake chopper is a factory installed option only, see drive options on **Page V6-T2-49**. External dynamic braking resistors not included. See **Page V6-T2-58**.
- ③ Includes local/remote speed reference switch.
- ④ Some options are voltage and/or horsepower specific. Consult your Eaton representative for details.
- ⑤ See **Page V6-T2-120** for descriptions.
- ⑥ See **Pages V6-T2-118** and **V6-T2-119** for complete descriptions.
- ⑦ Bypass options applicable only in the pump panel three-phase design.

Product Selection

When Ordering

- Select a base catalog number that meets the application requirements—nominal horsepower, voltage and enclosure rating (the enclosed drive's continuous output amp rating should be equal to or greater than the motor's full load amp rating). The base enclosed package includes a standard drive, door mounted local/remote keypad and enclosure.
- If dynamic brake chopper or control/communication option is desired, change the appropriate code in the base catalog number.
- Select enclosed options. Add the codes as suffixes to the base catalog number in alphabetical and numeric order.
- **Read all footnotes.**

208V Drives

SVX9000 Enclosed Drives



Pump Panel Style (Three-Phase)

Enclosure Size ①	hp	NEMA Type 12/IP54		NEMA Type 3R	
		Frame Size	Base Catalog Number ②	Frame Size	Base Catalog Number ②
High Overload Drive and Enclosure					
A	3/4	4	SVXF0721EP	4	SVXF0731EP
	1		SVX00121EP		SVX00131EP
	1-1/2		SVXF1521EP		SVXF1531EP
	2		SVX00221EP		SVX00231EP
	3	5	SVX00321EP	5	SVX00331EP
	5		SVX00521EP		SVX00531EP
	7-1/2		SVX00721EP		SVX00731EP
	10	6	SVX01021EP	6	SVX01031EP
15		SVX01521EP		SVX01531EP	
B	20	7	SVX02021DP	7	SVX02031DP
	25		SVX02521DP		SVX02531DP
	30		SVX03021DP		SVX03031DP
C	40	8	SVX04021DP	8	SVX04031DP
	50		SVX05021DP		SVX05031DP
	60		SVX06021DP		SVX06031DP
F	75	9	—	9	SVX07531DP
	100		—		SVX10031DP
Low Overload Drive and Enclosure					
A	1	4	SVX00121BP	4	SVX00131BP
	1-1/2		SVXF1521BP		SVXF1531BP
	2		SVX00221BP		SVX00231BP
	3		SVX00321BP		SVX00331BP
	5	5	SVX00521BP	5	SVX00531BP
	7-1/2		SVX00721BP		SVX00731BP
	10		SVX01021BP		SVX01031BP
	15	6	SVX01521BP	6	SVX01531BP
20		SVX02021BP		SVX02031BP	
B	25	7	SVX02521AP	7	SVX02531AP
	30		SVX03021AP		SVX03031AP
	40		SVX04021AP		SVX04031AP
C	50	8	SVX05021AP	8	SVX05031AP
	60		SVX06021AP		SVX06031AP
	75		SVX07521AP		SVX07531AP
F	100	9	—	9	SVX10031AP
	125		—		SVX12531AP

Notes

- ① Enclosure dimensions starting on **Page V6-T2-124**.
 ② Includes drive, local/remote keypad and enclosure.

230V Drives

SVX9000 Enclosed Drives

2



Pump Panel Style (Three-Phase)

Enclosure Size ①	hp	NEMA Type 12/IP54		NEMA Type 3R			
		Frame Size	Base Catalog Number ②	Frame Size	Base Catalog Number ②		
High Overload Drive and Enclosure							
A	3/4	4	SVXF0722EP	4	SVXF0732EP		
	1		SVX00122EP		SVX00132EP		
	1-1/2		SVXF1522EP		SVXF1532EP		
	2		SVX00222EP		SVX00232EP		
	5	3	5	SVX00322EP	5	SVX00332EP	
		5		SVX00522EP		SVX00532EP	
		7-1/2		SVX00722EP		SVX00732EP	
		10		6		SVX01022EP	SVX01032EP
		15				SVX01522EP	SVX01532EP
		B		20		7	SVX02022DP
25	SVX02522DP		SVX02532DP				
30	SVX03022DP		SVX03032DP				
C	40	8	SVX04022DP	8	SVX04032DP		
	50		SVX05022DP		SVX05032DP		
	60		SVX06022DP		SVX06032DP		
F	75	9	—	9	SVX07532DP		
	100		—		SVX10032DP		
Low Overload Drive and Enclosure							
A	1	4	SVX00122BP	4	SVX00132BP		
	1-1/2		SVXF1522BP		SVXF1532BP		
	2		SVX00222BP		SVX00232BP		
	3		SVX00322BP		SVX00332BP		
	5	5	5	SVX00522BP	5	SVX00532BP	
		7-1/2		SVX00722BP		SVX00732BP	
		10		SVX01022BP		SVX01032BP	
		15		6		SVX01522BP	SVX01532BP
		20				SVX02022BP	SVX02032BP
		B		25		7	SVX02522AP
30	SVX03022AP		SVX03032AP				
40	SVX04022AP		SVX04032AP				
C	50	8	SVX05022AP	8	SVX05032AP		
	60		SVX06022AP		SVX06032AP		
	75		SVX07522AP		SVX07532AP		
F	100	9	—	9	SVX10032AP		
	125		—		SVX12532AP		

Notes

- ① Enclosure dimensions starting on **Page V6-T2-124**.
- ② Includes drive, local/remote keypad and enclosure.

230V Drives, continued

SVX9000 Enclosed Drives



Pump Panel Style (Single-Phase)

Enclosure Size ^①	hp	NEMA Type 12/IP54		NEMA Type 3R	
		Frame Size	Base Catalog Number ^②	Frame Size	Base Catalog Number ^②
Low Overload Drive and Enclosure					
A	3/4	4	SVXF072JBP	4	SVXF073JBP
	1		SVX0012JBP		SVX0013JBP
	2	5	SVX0022JBP	5	SVX0023JBP
	3		SVX0032JBP		SVX0033JBP
	5		SVX0052JBP		SVX0053JBP
	7-1/2	6	SVX0072JBP	6	SVX0073JBP
	10		SVX0102JBP		SVX0103JBP
B	15	7	SVX0152JBP	7	SVX0153JBP
	20		SVX0202JAP		SVX0203JAP
C	25	8	SVX0252JAP	8	SVX0253JAP
	30		SVX0302JAP		SVX0303JAP
	40		SVX0402JAP		SVX0403JAP

Notes

- ① Enclosure dimensions starting on **Page V6-T2-124**.
 ② Includes drive, local/remote keypad and enclosure.

480V Drives

SVX9000 Enclosed Drives

2



Pump Panel Style (Three-Phase)

Enclosure Size ①	hp	NEMA Type 12/IP54		NEMA Type 3R	
		Frame Size	Base Catalog Number ②	Frame Size	Base Catalog Number ②
High Overload Drive and Enclosure					
A	1	4	SVX00124EP	4	SVX00134EP
	1-1/2		SVXF1524EP		SVXF1534EP
	2		SVX00224EP		SVX00234EP
	3		SVX00324EP		SVX00334EP
	5		SVX00524EP		SVX00534EP
	7-1/2	5	SVX00724EP		SVX00734EP
	10		SVX01024EP		SVX01034EP
	15		SVX01524EP		SVX01534EP
	20	6	SVX02024EP		SVX02034EP
	25		SVX02524EP		SVX02534EP
B	30	7	SVX03024EP	7	SVX03034EP
	40		SVX04024DP		SVX04034DP
	50		SVX05024DP		SVX05034DP
	60		SVX06024DP		SVX06034DP
C	75	8	SVX07524DP	8	SVX07534DP
	100		SVX10024DP		SVX10034DP
	125		SVX12524DP		SVX12534DP
F	150	9	—	9	SVX15034DP
	200		—		SVX20034DP
	250	10	—	10	SVX25034DP
	300		—		SVX30034DP
	350		—		SVX35034DP
	400		11 ③		—
500	—	SVX50034DP			
Low Overload Drive and Enclosure					
A	1-1/2	4	SVXF1524BP	4	SVXF1534BP
	2		SVX00224BP		SVX00234BP
	3		SVX00324BP		SVX00334BP
	5		SVX00524BP		SVX00534BP
	7-1/2		SVX00724BP		SVX00734BP
	10	5	SVX01024BP		SVX01034BP
	15		SVX01524BP		SVX01534BP
	20		SVX02024BP		SVX02034BP
	25	6	SVX02524BP		SVX02534BP
	30		SVX03024BP		SVX03034BP
B	40	7	SVX04024BP	7	SVX04034BP
	50		SVX05024AP		SVX05034AP
	60		SVX06024AP		SVX06034AP
	75		SVX07524AP		SVX07534AP
C	100	8	SVX10024AP	8	SVX10034AP
	125		SVX12524AP		SVX12534AP
	150		SVX15024AP		SVX15034AP
F	200	9	—	9	SVX20034AP
	250		—		SVX25034AP
	300	10	—	10	SVX30034AP
	350		—		SVX35034AP
	400		—		SVX40034AP
	500		11 ③		—
600	—	SVX60034AP			

Notes

- ① Enclosure dimensions starting on **Page V6-T2-124**.
- ② Includes drive, local/remote keypad and enclosure.
- ③ FR11 has limited power options available.

480V Drives, continued

SVX9000 Enclosed Drives



Pump Panel Style (Single-Phase)

Enclosure Size ①	hp	NEMA Type 12/IP54		NEMA Type 3R	
		Frame Size	Base Catalog Number ②	Frame Size	Base Catalog Number ②
Low Overload Drive and Enclosure					
A	3/4	4	SVXF072KBP	4	SVXF073KBP
	1		SVX0012KBP		SVX0013KBP
	2		SVX0022KBP		SVX0023KBP
	3		SVX0032KBP		SVX0033KBP
	5	5	SVX0052KBP	5	SVX0053KBP
	7-1/2		SVX0072KBP		SVX0073KBP
	10		SVX0102KBP		SVX0103KBP
	15		SVX0152KBP		SVX0153KBP
20	6	SVX0202KBP	6	SVX0203KBP	
B	25	7	SVX0252KAP	7	SVX0253KAP
	30		SVX0302KAP		SVX0303KAP
C	40	8	SVX0402KAP	8	SVX0403KAP
	50		SVX0502KAP		SVX0503KAP
	60		SVX0602KAP		SVX0603KAP

Notes

- ① Enclosure dimensions starting on **Page V6-T2-124**.
 ② Includes drive, local/remote keypad and enclosure.

Options

9000X Series Option Board Kits

2

The 9000X Series drives can accommodate a wide selection of expander and adapter option boards to customize the drive for your application needs. The drive's control unit is designed to accept a total of five option boards.

The 9000X Series factory installed standard board configuration includes an A9 I/O board and an A2 relay output board, which are installed in slots A and B.

Option Boards

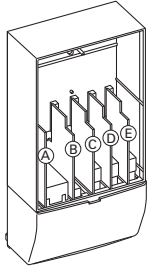

Option Board Kits

Option Kit Description ^①	Allowed Slot Locations ^②	Field Installed Catalog Number	Factory Installed Option Designator	SVX Ready Programs						
				Basic	Local/Remote	Standard	MSS	PID	Multi-P.	PFC
Standard I/O Cards										
6 DI, 1 DO, 2 AI, 1AO, 1 +10 Vdc ref, 2 ext +24 Vdc/EXT +24 Vdc	A	OPTA9	—	■	■	■	■	■	■	■
2 RO (NC-NO)	B	OPTA2	—	■	■	■	■	■	■	■
Extended I/O Cards										
6 DI, 1 ext +24 Vdc/EXT +24 Vdc	B, C, D , E	OPTB1	B1	—	—	—	—	—	■	■
1 RO (NC-NO), 1 RO (NO), 1 therm	B, C, D , E	OPTB2	B2	—	—	—	—	—	■	■
1 AI (mA isolated), 2 AO (mA isolated), 1 ext +24 Vdc/EXT +24 Vdc	B, C, D , E	OPTB4	B4	■	■	■	■	■	■	■
3 RO (NO)	B, C, D , E	OPTB5	B5	—	—	—	—	—	■	■
1 ext +24 Vdc/EXT +24 Vdc, 3 Pt100	B, C, D , E	OPTB8	B8	—	—	—	—	—	—	—
1 RO (NO), 5 DI 42–240 Vac input	B, C, D , E	OPTB9	B9	—	—	—	—	—	■	■
Communication Cards										
Modbus ^③	D, E	OPTC2	C2	■	■	■	■	■	■	■
Modbus TCP	D, E	OPTC1	C1	■	■	■	■	■	■	■
BACnet	D, E	OPTCJ	CJ	■	■	■	■	■	■	■
EtherNet/IP	D, E	OPTCQ	CQ	■	■	■	■	■	■	■
Johnson Controls N2 ^③	D, E	OPTC2	CA	—	—	—	—	—	—	—
PROFIBUS DP	D, E	OPTC3	C3	■	■	■	■	■	■	■
LonWorks	D, E	OPTC4	C4	■	■	■	■	■	■	■
PROFIBUS DP (D9 connector)	D, E	OPTC5	C5	■	■	■	■	■	■	■
CANopen (slave)	D, E	OPTC6	C6	■	■	■	■	■	■	■
DeviceNet	D, E	OPTC7	C7	■	■	■	■	■	■	■
Modbus (D9 type connector)	D, E	OPTC8	C8	■	■	■	■	■	■	■
RS-232 with D9 connection	D, E	OPTD3	D3	■	■	■	■	■	■	■

Notes

- ① AI = Analog Input; AO = Analog Output, DI = Digital Input, DO = Digital Output, RO = Relay Output
- ② Option card must be installed in one of the slots listed for that card. Slot indicated in bold is the preferred location.
- ③ OPTC2 is a multi-protocol option card.

Modbus RTU Network Communications

The Modbus Network Card OPTC2 is used for connecting the 9000X Drive as a slave on a Modbus network. The interface is connected by a 9-pin DSUB connector (female) and the baud rate ranges from 300 to 19200 baud. Other communication parameters include an address range from 1 to 247; a parity of None, Odd or Even; and the stop bit is 1.

PROFIBUS Network Communications

The PROFIBUS Network Card OPTC3 is used for connecting the 9000X Drive as a slave on a PROFIBUS-DP network. The interface is connected by a 9-pin DSUB connector (female). The baud rates range from 9.6K baud to 12M baud, and the addresses range from 1 to 127.

LonWorks Network Communications

The LonWorks Network Card OPTC4 is used for connecting the 9000X Drive on a LonWorks network. This interface uses Standard Network Variable Types (SNVT) as data types. The channel connection is achieved using a FTT-10A Free Topology transceiver via a single twisted transfer cable. The communication speed with LonWorks is 78 kBits/s.

CANopen (Slave) Communications

The CANopen (Slave) Network Card OPTC6 is used for connecting the 9000X Drive to a host system. According to ISO11898 standard cables to be chosen for CAN bus should have a nominal impedance of 120 ohms, and specific line delay of nominal 5 nS/m. 120 ohms line termination resistors required for installation.

DeviceNet Network Communications

The DeviceNet Network Card OPTC7 is used for connecting the 9000X Drive on a DeviceNet Network. It includes a 5.08 mm pluggable connector. Transfer method is via CAN using a two-wire twisted shielded cable with two-wire bus power cable and drain. The baud rates used for communication include 125K baud, 250K baud and 500K baud.

Johnson Controls Metasys N2 Network Communications

The OPTC2 fieldbus board provides communication between the 9000X Drive and a Johnson Controls Metasys™ N2 network. With this connection, the drive can be controlled, monitored and programmed from the Metasys system. The N2 fieldbus is available as a factory installed option and as a field installable kit.

Modbus/TCP Network Communications

The Modbus/TCP Network Card OPTC1 is used for connecting the 9000X Drive to Ethernet networks utilizing Modbus protocol. It includes an RJ-45 pluggable connector. This interface provides a selection of standard and custom register values to communicate drive parameters. The board supports 10 Mbps and 100 Mbps communication speeds. The IP address of the board is configurable over Ethernet using a supplied software tool.

BACnet Network Communications

The BACnet Network Card OPTCJ is used for connecting the 9000X Drive to BACnet networks. It includes a 5.08 mm pluggable connector. Data transfer is Master-Slave/Token Passing (MS/TP) RS-485. This interface uses a collection of 30 Binary Value Objects (BVOs) and 35 Analog Value Objects (AVOs) to communicate drive parameters. The card supports 9.6, 19.2 and 38.4 Kbaud communication speeds and supports network addresses 1–127.

EtherNet/IP Network Communications

The EtherNet/IP Network Card OPTCK is used for connecting the 9000X Drive to Ethernet/Industrial Protocol networks. It includes an RJ-45 pluggable connector. The interface uses CIP objects to communicate drive parameters (CIP is “Common Industrial Protocol”, the same protocol used by DeviceNet). The board supports 10 Mbps and 100 Mbps communication speeds. The IP address of the board is configurable by Static, BOOTP and DHCP methods.

Control/Communication Option Descriptions

For availability, see Product Selection for base drive voltage required.

2

Available Control/Communications Options

Option	Description	Option Type
K1	Door-Mounted Speed Potentiometer —Provides the SVX9000 with the ability to adjust the frequency reference using a door-mounted potentiometer. This option uses the 10 Vdc reference to generate a 0–10V signal at the analog voltage input signal terminal. When the HOA bypass option is added, the speed is controlled when the HOA switch is in the HAND position. Without the HOA bypass option, a two-position switch (labeled local/remote) is provided on the keypad to select speed reference from the Speed Potentiometer or a remote speed signal.	Control
K2	Door-Mounted Speed Potentiometer with HOA Selector Switch —Provides the SVX9000 with the ability to start/stop and adjust the speed reference from door-mounted control devices or remotely from customer supplied inputs. In HAND position, the drive will start and the speed is controlled by the door-mounted speed potentiometer. The drive will be disabled in the OFF position. When AUTO is selected, the drive run and speed control commands are via user-supplied dry contact and 4–20 mA signal.	Control
K5	MANUAL/AUTO Speed Reference Switch —Provides a door-mounted selector switch for MANUAL/AUTO speed reference.	Control
K6	START and STOP Pushbuttons (22 mm) —START (green) STOP (red). Provide door-mounted START and STOP pushbuttons for either bypass or non-bypass configurations.	Control
K9	(2) Factory Installed Auxiliary Contacts —Provide two NO/NC auxiliary contacts.	Power
L2	Bypass Pilot Lights for RA and RB Bypass Options —A green MOTOR ON INVERTER light indicates when the motor is running in inverter mode and an amber MOTOR ON BYPASS light indicates when the motor is running in bypass mode. The lights are mounted on the enclosure door, above the switches.	Addl. bypass
LD	Green STOP Light (22 mm) —Provides a green STOP light that indicates the drive is stopped.	Light
LE	Red RUN Pilot Light (22 mm) —Provides a red RUN pilot light that indicates the drive is running.	Light
LU	Misc. Light (22 mm) —Provides a misc. “user defined” pilot light. User to define light function and color.	Light
LW	PTT (Push-To-Test) Light (22 mm) —Provides misc. “user defined” PTT pilot light. User to define light function and color.	Light
P1	Input Circuit Breaker —Provides a means of short-circuit protection for the power cables between it and the SVX9000, and protection from high-level ground faults on the power cable. Allows a convenient means of disconnecting the SVX9000 from the line and the operating mechanism can be padlocked in the OFF position. This is factory mounted in the enclosure.	Input
P3	Input Line Fuses Rated to 200 kAIC —Provide high-level fault protection of the SVX9000 input power circuit from the load side of the fuses to the input side of the power transistors. This option consists of three 200 kA fuses, which are factory mounted in the enclosure.	Input
P8	SPD (50 kA per Phase) —Provides a surge protection device (SPD) connected to the line side terminals and is designed to clip line side transients. Rated for 50,000A.	Input
PA	SPD (100 kA per Phase) —Provides a surge protection device (SPD) connected to the line side terminals and is designed to clip line side transients. Rated for 100,000A.	Input
PE	Output Contactor —Provides a means for positive disconnection of the drive output from the motor terminals. The contactor coil is controlled by the drive’s run or permissive logic. NC and NO auxiliary contacts rated at 10A, 600 Vac are provided for customer use. Bypass option RA includes an output contactor as standard. This option includes a low VA 115 Vac fused control power transformer and is factory mounted in the enclosure.	Output
RA	Manual HOA Bypass Controller —The Manual HAND/OFF/AUTO (HOA)—3-contactor—bypass option provides a means of bypassing the SVX9000, allowing the AC motor to be operated at full speed directly from the AC supply line. This option consists of an input disconnect, a fused control power transformer, and a full voltage bypass starter with a door mounted HOA selector switch and an INVERTER/BYPASS switch. The HOA switch provides the ability to start and stop the drive in the inverter mode. For applications up to 100 hp, a Freedom Series IEC input contactor, a Freedom Series IEC output contactor, and a Freedom Series IEC starter with a bimetallic overload relay is included. For applications above 100 hp, an Advantage input contactor, an Advantage output contactor and an Advantage starter with electronic overload protection is included. The contactors are mechanically and electrically interlocked.	Bypass
RB	Manual IOB Bypass Controller —The manual INVERTER/OFF/BYPASS (IOB)—3-contactor—bypass option provides a means of bypassing the SVX9000, allowing the AC motor to be operated at full speed directly from the AC supply line. This option consists of an input disconnect, a fused control power transformer, and a full voltage bypass starter with a door mounted IOB selector switch. For applications up to 100 hp, a Freedom Series IEC input contactor, a Freedom Series IEC output contactor, and a Freedom Series IEC starter with a bimetallic overload relay is included. For applications above 100 hp, an Advantage input contactor, an Advantage output contactor and an Advantage starter with electronic overload protection is included. The contactors are mechanically and electrically interlocked.	Bypass
S5	Floor Stand 22 in —Converts a Size A or B, normally wall mounted enclosure to a floor standing enclosure with a height of 22 in (558.8 mm).	Enclosure
S9	Space Heater without CPT —Prevents condensation from forming in the enclosure when the drive is inactive or in storage. Includes a thermostat for variable temperature control. A 200W heater is installed in enclosures A and B, and 400W heater is installed in enclosures C and D. Requires a customer supplied 115V remote supply source.	Enclosure
SA	Space Heater with CPT —Prevents condensation from forming in the enclosure when the drive is inactive or in storage. Includes a thermostat for variable temperature control. A 200W heater is installed in enclosures A and B, and 400W heater is installed in enclosures C and D. Provided with CPT connected to load side of input disconnect.	Enclosure
SB	Ice Cube Style Control Relay —Provides misc. “user defined” 4PDT control relay. Requires user to define functionality.	Enclosure
SE	On-Delay Timer (Delay on Make) —Provides misc. “user defined” time delay relay. Requires user to define functionality and time setting requirement.	Enclosure
SF	Off-Delay Timer (Delay on Break) —Provides misc. “user defined” time delay relay. Requires user to define functionality and time setting requirement.	Enclosure

Technical Data and Specifications

9000X VFD Pump Panels

Description	NEMA Type 12/IP54 or NEMA Type 3R Specification
Primary Design Features	
45–66 Hz input frequency	Standard
Output (AC volts maximum)	Input voltage base
Output frequency range	0–320 Hz
Initial output current (I_H)	250% for 2 seconds
Overload (1 minute (I_H/I_L))	150%/110%
Enclosure space heater	Optional
Oversize enclosure	Standard
Output contactor	Optional
Bypass motor starter	Optional
Listings	UL, cUL
Protection Features	
Incoming line fuses	Optional
AC input circuit disconnect	Optional
Line reactors (3%)	Standard
Phase rotation insensitive	Standard
EMI filter	Standard—Thru Frame 9
Input phase loss protection	Standard
Input overvoltage protection	Standard
Line surge protection	Optional
Output short-circuit protection	Standard
Output ground fault protection	Standard
Output phase protection	Standard
Overtemperature protection	Standard
DC overvoltage protection	Standard
Drive overload protection	Standard
Motor overload protection	Standard
Programmer software	Optional
Local/remote keypad	Standard
Keypad lockout	Standard
Fault alarm output	Standard
Built-in diagnostics	Standard

Description	NEMA Type 12/IP54 or NEMA Type 3R Specification
Input/Output Interface Features	
Setup adjustment provisions	
Remote keypad/display	Standard
Personal computer	Standard
Operator control provisions	
Drive mounted keypad/display	Standard
Remote keypad/display	Standard
Conventional control elements	Standard
Serial communications	Optional
115 Vac control circuit	Optional
Speed setting inputs	
Keypad	Standard
0–10 Vdc potentiometer/voltage signal	Standard
4–20 mA isolated	Configurable
4–20 mA differential	Configurable
Analog outputs	
Speed/frequency	Standard
Torque/load/current	Programmable
Motor voltage	Programmable
Kilowatts	Programmable
0–10 Vdc signals	Configurable w/jumpers
4–20 mA DC signals	Standard
Isolated signals	Optional
Discrete outputs	
Fault alarm	Standard
Drive running	Standard
Drive at set speed	Programmable
Optional parameters	14
Dry contacts	1 (2 relays Form C)
Open collector outputs	1
Additional discrete outputs	Optional
Communications	
RS-232	Standard
RS-422/485	Optional
DeviceNet™	Optional
Modbus RTU	Optional
CANopen (slave)	Optional
PROFIBUS-DP	Optional
Lonworks®	Optional
Johnson Controls Metasys™ N2	Optional
EtherNet/IP	Optional
Modbus TCP	Optional
BACnet	Optional

9000X VFD Pump Panels, continued

Description	NEMA Type 12/IP54 or NEMA Type 3R Specification
Performance Features	
Sensorless vector control	Standard
Volts/hertz control	Standard
IR and slip compensation	Standard
Electronic reversing	Standard
Dynamic braking	Optional ^①
DC braking	Standard
PID setpoint controller	Programmable
Critical speed lockout	Standard
Current (torque) limit	Standard
Adjustable acceleration/deceleration	Standard
Linear or S curve accel/decel	Standard
Jog at preset speed	Standard
Thread/preset speeds	7 Standard, 15 Optional
Automatic restart	Selectable
Coasting motor start	Standard
Coast or ramp stop selection	Standard
Elapsed time meter	Optional
Carrier frequency adjustment	1–16 kHz
Standard Conditions for Application and Service	
Operating ambient temperature	0 to 40°C
Storage temperature	–40 to 60°C
Humidity (maximum), non-condensing	95%
Altitude (maximum without derate)	3300 ft (1000m)
Line voltage variation	+10/–15%
Line frequency variation	45–66 Hz
Efficiency	>96%
Power factor (displacement)	0.96

Standard I/O Specifications

Description	Specification
Six–digital input programmable	24V: “0” ≤10V, “1” ≥18V, R _i >5 kohms
Two–analog input configurable w/jumpers	Voltage: 0–±10V, R _i >200 kohms Current: 0 (4)–20 mA, R _i = 250 ohms
Two–digital output programmable	Form C relays 250 Vac 30 Vdc 2 amp resistive
One–analog output programmable configurable w/jumper	0–20 mA, R _L max. 500 ohms 10 bits ±2%
One digital output programmable	Open collector 48 Vdc 50 mA

I/O Specifications for Control/Communication Options

Description	Specification
Analog voltage, input	0–±10V, R _i ≥200 kohms
Analog current, input	0 (4)–20 mA, R _i = 250 ohms
Digital input	24V: “0” ≤10V, “1” ≥18V, R _i >5 kohms
Auxiliary voltage	24V (±20%), max. 50 mA
Reference voltage	10V ±3%, max. 10 mA
Analog current, output	0 (4)–20 mA, R _L = 500 kohms, resolution 10 bit, accuracy ≤±2%
Analog voltage, output	0 (2)–10V, R _L ≥1 k kohms, resolution 10 bit, accuracy ≤±2%
Relay output	
Maximum switching voltage	300 Vdc, 250 Vac
Maximum switching load	8A/24 Vdc, 0.4A/300 Vdc, 2 kVA/250 Vac
Maximum continuous load	2A rms
Thermistor input	R _{trip} = 4.7 kohms

Note

^① Some horsepower units include dynamic braking chopper as standard—refer to individual drive sections.

Wiring Diagrams

A9 Board Control Wiring

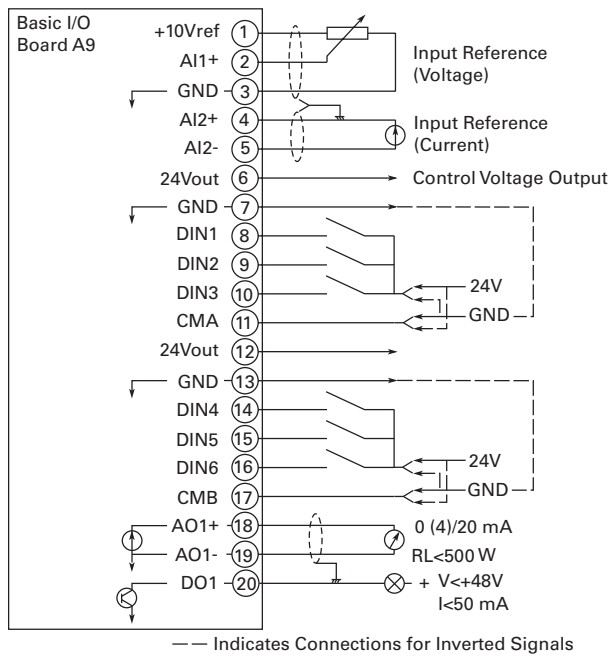

A2 Board Control Wiring

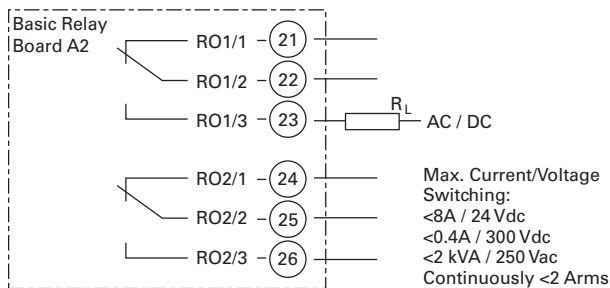

SVX9000 Pump Panel Bypass Power Wiring

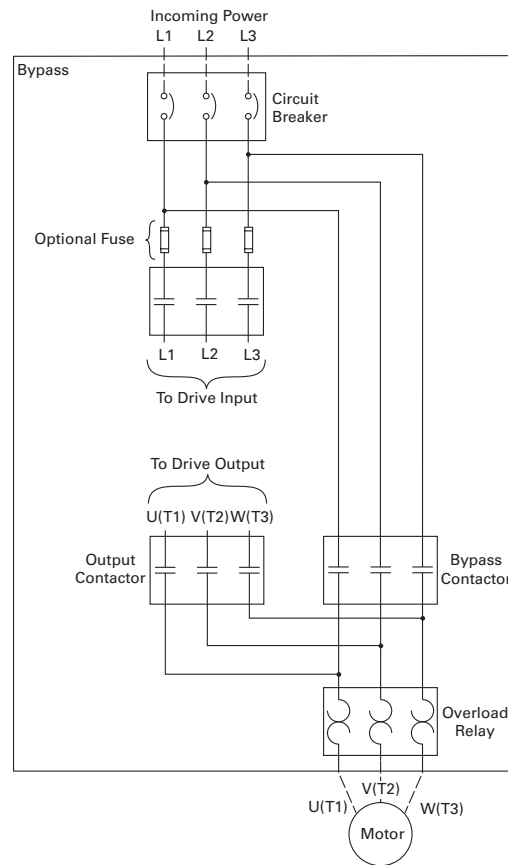

SVX9000 Pump Panel Disconnect Power Wiring

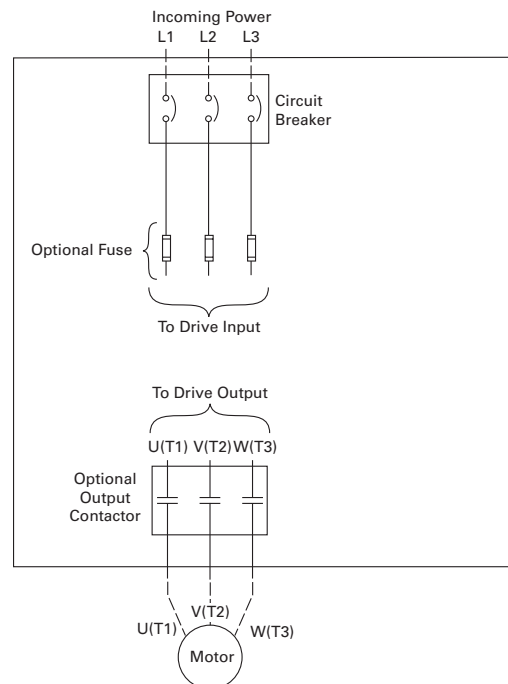

2.5

Adjustable Frequency Drives

SVX9000 Drives

Dimensions

Approximate Dimensions in Inches (mm)

2

SVX9000 Pump Application Drives

Enclosure Box A NEMA Type 12/IP54

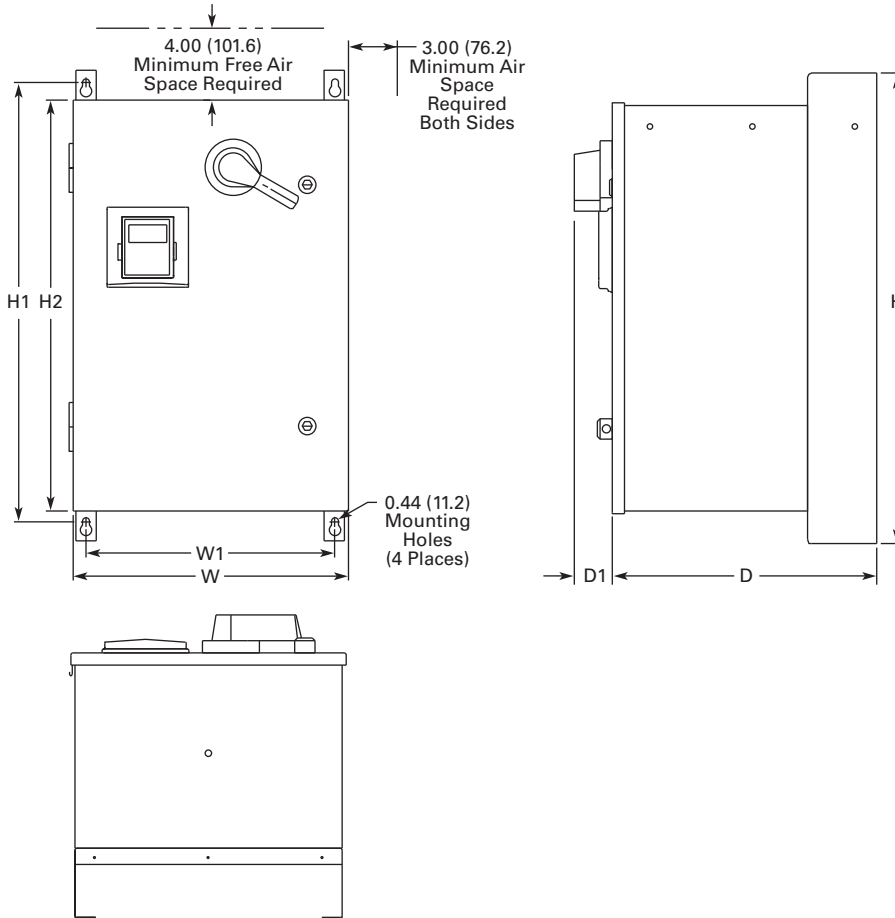

Voltage AC	hp (I _H)	hp (I _L)	H	H1	H2	W	W1	D	D1	Approx. Weight Lbs (kg)	Approx. Shipping Weight Lbs (kg)
Three-Phase											
208V	3/4–10	1–15	29.00	27.00	25.35	16.92	15.30	16.26	2.34	120 (54)	160 (73)
230V	3/4–10	1–15	(736.6)	(685.8)	(643.9)	(429.8)	(388.6)	(413.0)	(59.4)		
480V	1–25	1–30									
Single-Phase											
230V	—	3/4–10	29.00	27.00	25.35	16.92	15.30	16.26	2.34	120 (54)	160 (73)
480V	—	3/4–20	(736.6)	(685.8)	(643.9)	(429.8)	(388.6)	(413.0)	(59.4)		

Approximate Dimensions in Inches (mm)

Enclosure Box B NEMA Type 12/IP54

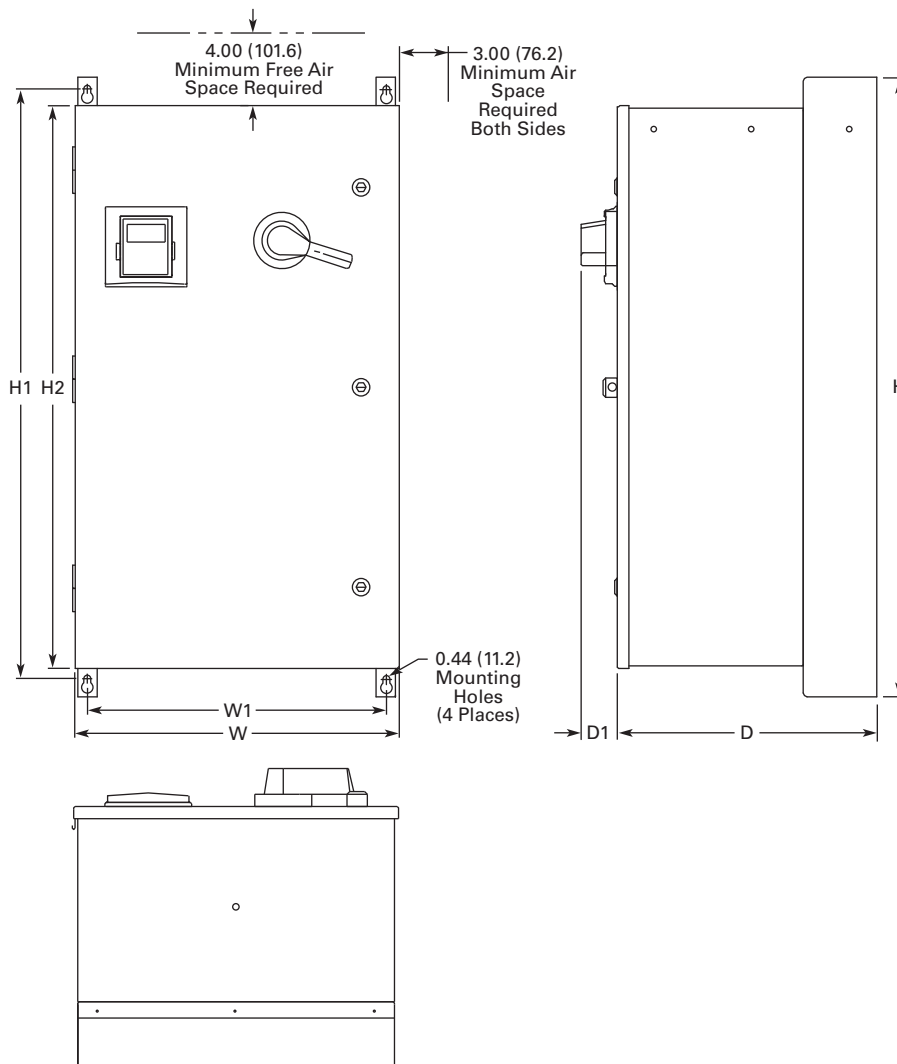

Voltage AC	hp (I _H)	hp (I _L)	H	H1	H2	W	W1	D	D1	Approx. Weight Lbs (kg)	Approx. Shipping Weight Lbs (kg)
Three-Phase											
208V	15–25	20–30	40.00	38.00	36.35	20.92	19.30	16.76	2.34	185 (84)	229 (104)
230V	15–25	20–30	(1016.0)	(965.2)	(923.3)	(531.4)	(490.2)	(425.7)	(59.4)		
480V	30–60	40–75									
Single-Phase											
230V	—	15–20	40.00	38.00	36.35	20.92	19.30	16.76	2.34	185 (84)	229 (104)
480V	—	25–30	(1016.0)	(965.2)	(923.3)	(531.4)	(490.2)	(425.7)	(59.4)		

2.5

Adjustable Frequency Drives

SVX9000 Drives

Approximate Dimensions in Inches (mm)

Enclosure Box C NEMA Type 12/IP54

2

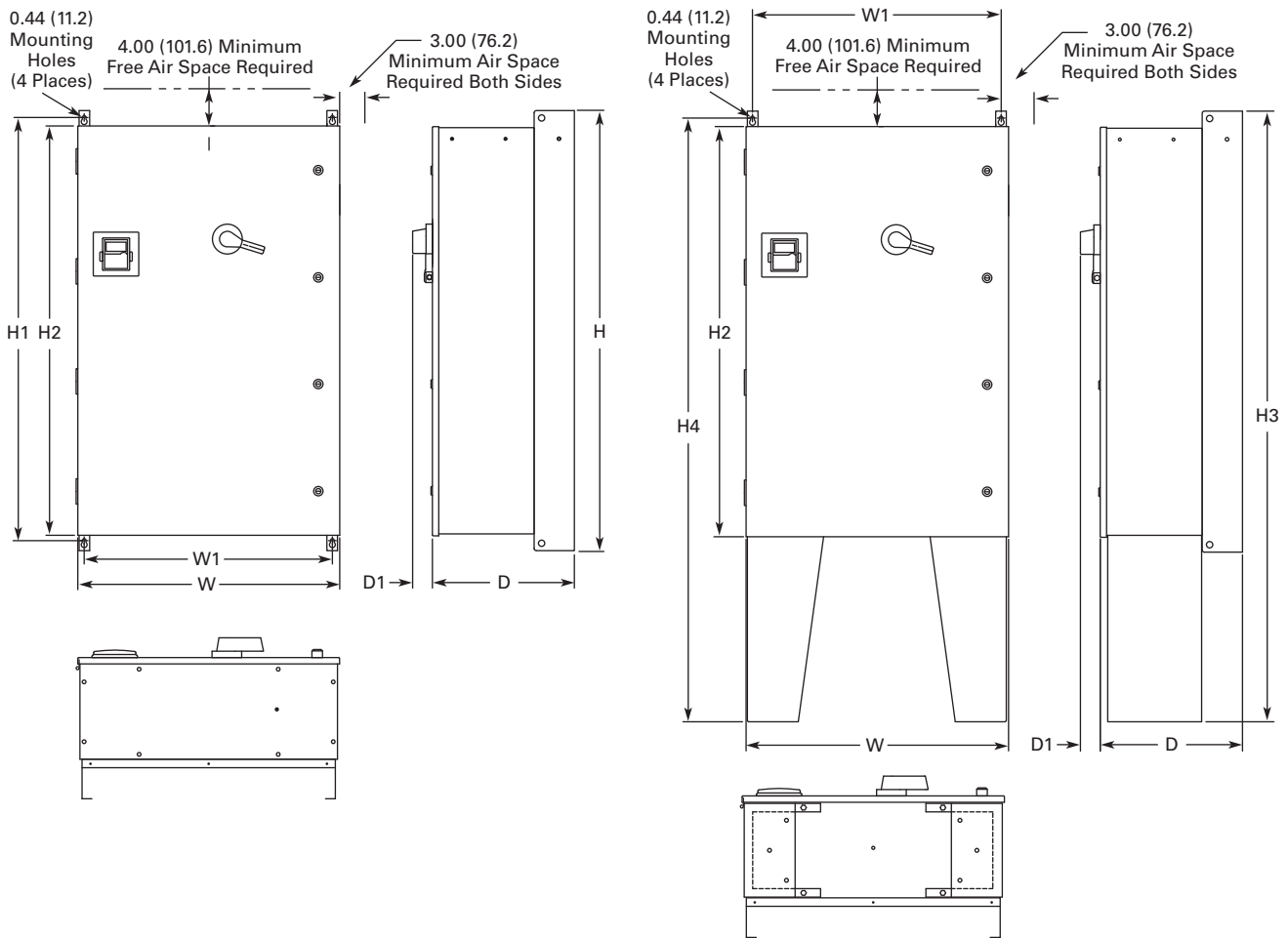

Voltage AC	hp (I _H)	hp (I _L)	H	H1	H2	H3	H4	W	W1	D	D1	Approx. Shipping Weight Lbs (kg)
Three-Phase												
208V	30–50	40–60	52.00 (1320.8)	50.00 (1270.0)	48.35 (1228.1)	72.00 (1828.8)	71.19 (1808.2)	30.92 (785.4)	29.30 (744.2)	16.78 (426.2)	2.34 (59.4)	①
230V	30–50	40–60										
480V	75–125	100–150										
Single-Phase												
230V	—	25–40	52.00 (1320.8)	50.00 (1270.0)	48.35 (1228.1)	72.00 (1828.8)	71.19 (1808.2)	30.92 (785.4)	29.30 (744.2)	16.78 (426.2)	2.34 (59.4)	①
480V	—	40–60										

Note
① Consult factory.

Approximate Dimensions in Inches (mm)

Enclosure Box A NEMA Type 3R

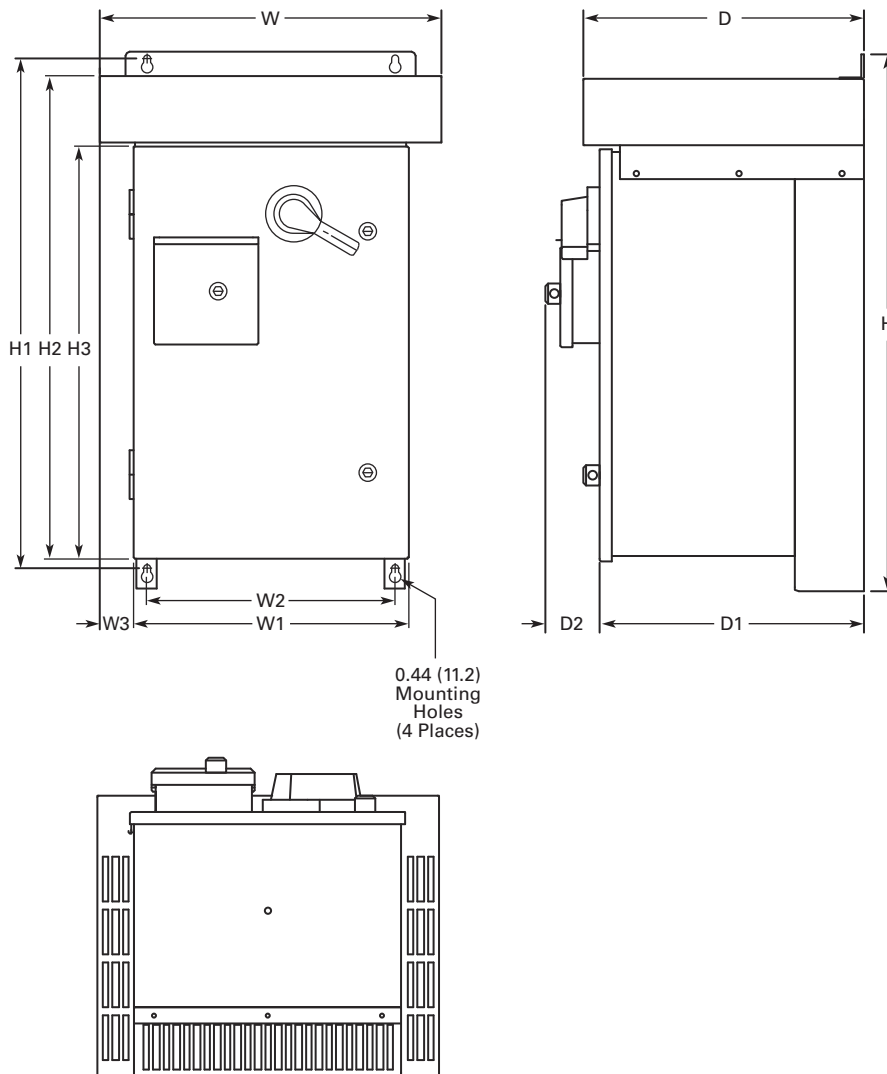

Voltage AC	hp (I _H)	hp (I _L)	H	H1	H2	H3	W	W1	W2	W3	D	D1	D2	Approx. Weight Lbs (kg)	Approx. Shipping Weight Lbs (kg)
Three-Phase															
208V	3/4–10	1–15	33.00 (838.2)	31.36 (796.5)	29.67 (753.6)	25.35 (643.9)	21.05 (534.7)	16.92 (429.8)	15.30 (388.6)	2.07 (52.6)	17.24 (437.9)	16.26 (413.0)	3.31 (84.1)	170 (77)	215 (98)
230V	3/4–10	1–15													
480V	1–25	1–30													
Single-Phase															
230V	—	3/4–10	33.00 (838.2)	31.36 (796.5)	29.67 (753.6)	25.35 (643.9)	21.05 (534.7)	16.92 (429.8)	15.30 (388.6)	2.07 (52.6)	17.24 (437.9)	16.26 (413.0)	3.31 (84.1)	170 (77)	215 (98)
480V	—	3/4–20													

2.5

Adjustable Frequency Drives

SVX9000 Drives

Approximate Dimensions in Inches (mm)

Enclosure Box B NEMA Type 3R

2

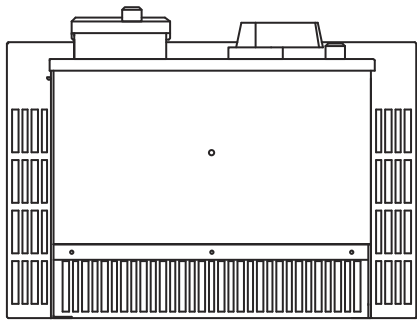
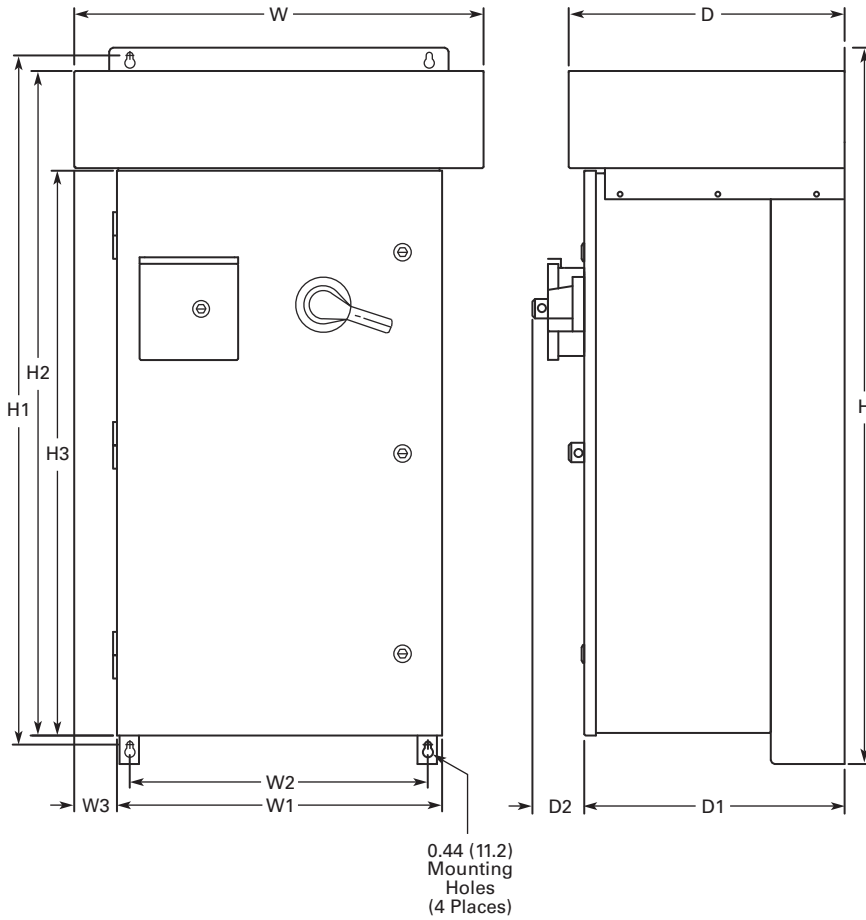

Voltage AC	hp (I _H)	hp (I _L)	H	H1	H2	H3	W	W1	W2	W3	D	D1	D2	Approx. Weight Lbs (kg)	Approx. Shipping Weight Lbs (kg)
Three-Phase															
208V	15–25	20–30	46.09	44.45	42.77	36.35	26.31	20.92	19.30	2.69	17.74	16.76	3.31	235	290
230V	15–25	20–30	(1170.7)	(1129.0)	(1086.4)	(923.3)	(668.3)	(531.4)	(490.2)	(68.3)	(450.6)	(425.7)	(84.1)	(107)	(132)
480V	30–60	40–75													
Single-Phase															
230V	—	15–20	46.09	44.45	42.77	36.35	26.31	20.92	19.30	2.69	17.74	16.76	3.31	235	290
480V	—	25–30	(1170.7)	(1129.0)	(1086.4)	(923.3)	(668.3)	(531.4)	(490.2)	(68.3)	(450.6)	(425.7)	(84.1)	(107)	(132)

Approximate Dimensions in Inches (mm)

Enclosure Box C NEMA Type 3R

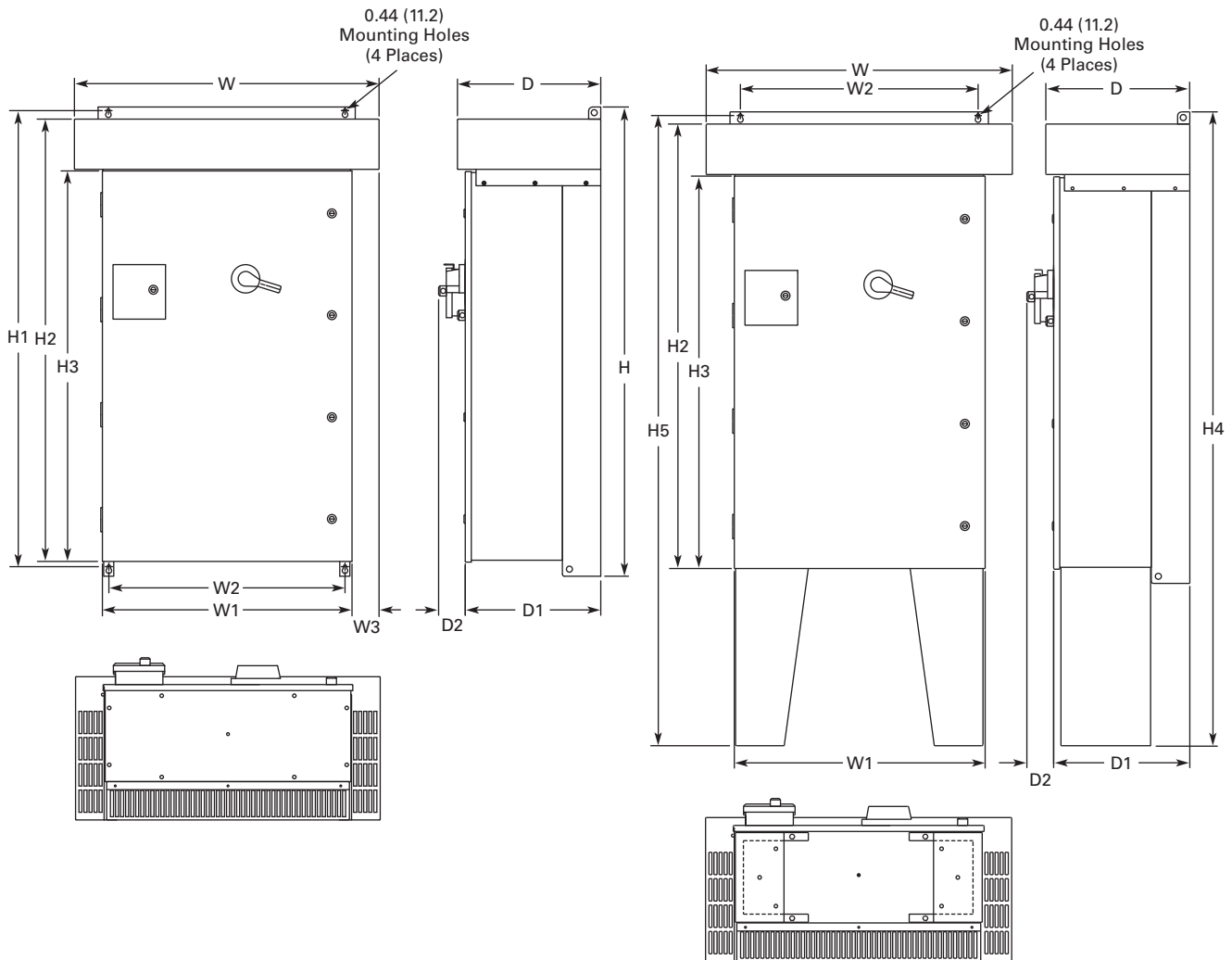

Voltage AC	hp (I _H)	hp (I _L)	H	H1	H2	H3	H4	H5	W	W1	W2	W3	D	D1	D2	Approx. Weight Lbs (kg)
Three-Phase																
208	30–50	40–60	58.09 (1475.5)	56.45 (1433.8)	54.77 (1391.2)	48.35 (1228.1)	78.09 (1983.5)	77.64 (1972.1)	37.73 (958.3)	30.92 (785.4)	29.30 (744.2)	3.34 (84.8)	17.74 (450.6)	16.77 (426.0)	3.31 (84.1)	①
230	30–50	40–60														
480	75–125	100–150														
Single-Phase																
230V	—	25–40	58.09 (1475.5)	56.45 (1433.8)	54.77 (1391.2)	48.35 (1228.1)	78.09 (1983.5)	77.64 (1972.1)	37.73 (958.3)	30.92 (785.4)	29.30 (744.2)	3.34 (84.8)	17.74 (450.6)	16.77 (426.0)	3.31 (84.1)	①
480V	—	40–60														

Note

① Consult factory.

2.5

Adjustable Frequency Drives

SVX9000 Drives

Approximate Dimensions in Inches (mm)

Enclosure Size F

2

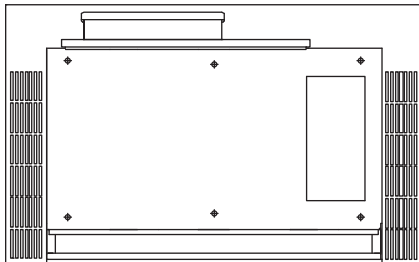
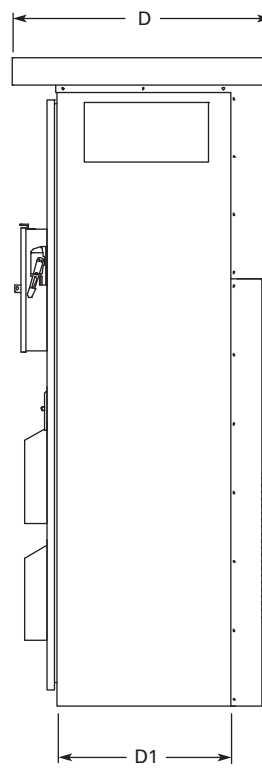
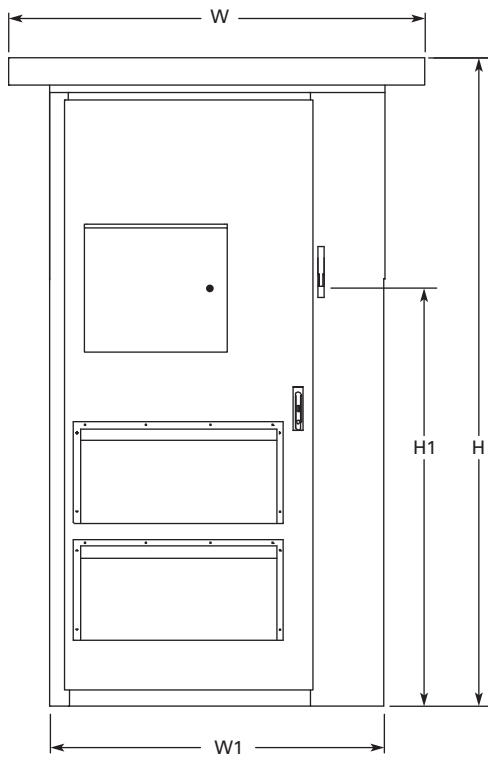

H	H1	W	W1	D	D1	Approximate Weight Lbs (kg)	Approximate Shipping Weight Lbs (kg)
93.58 (2376.9)	69.51 (1765.60)	60.00 (1524.0)	48.00 (1219.2)	37.50 (952.5)	26.00 (660.4)	1700 (771)	1850 (839)

H-Max Series Drives



Contents

Description	Page
H-Max Series Drives	
H-Max Drives	V6-T2-132
H-Max IntelliPass and IntelliDisconnect Drives	V6-T2-141

Product Overview

H-Max Family Introduction

Eaton's H-Max™ Series VFD is the next generation of drives specifically engineered for HVAC pump and fluid control applications. The H-Max family of products boasts industry leading energy efficiency algorithms for your applications. Not only are the drives ultra-efficient—they contain software that minimizes motor winding energy losses in your applications. Designed for easy installation, simple startup, and long life; the H-Max Series drive family provides exceptional value to our customers,

Product Range**Open Style Drives:**

- 0.75–125 hp at 230 Vac
- 1.5–250 hp at 480 Vac

Note: Available in NEMA 1 or NEMA 12 designs.

IntelliPass/IntelliDisconnect Drives:

- 1–30 hp at 208 Vac
- 1–30 hp at 230 Vac
- 1–75 hp at 480 Vac

Note: Available in NEMA 1, NEMA 12, or NEMA 3R enclosures.

Application Description

The H-Max Series drive was designed specifically for HVAC pump and fluid control applications. It is intended to be used on variable torque loads with the intent of moving air or liquids. With this in mind, the H-Max drive has onboard I/O pre-programmed to meet the common needs for these applications. The H-Max drive supports items such as standard speed control, PID functionality, as well as multi-motor applications. The drive easily supports interlock, second motor parameter set, as well as fire mode functionality.

Key Feature

Active Energy Control Algorithm

Eaton's H-Max Series drives have been designed to provide industry leading energy saving solutions. Not only is the drive ultra-efficient, the drive seeks the most efficient operating point of the motor, minimizing energy loss in the windings per the given load requirements. This is an Eaton protected control algorithm exclusive to H-Max drives.

H-Max Drives

2



H-Max Drives

Product Description

Eaton's H-Max Series VFD has software and hardware designed specifically for the HVAC, pump industry. The ultra-efficient DC capacitor and power structure allows the drive to consume less energy, lowering greenhouse gases.

The I/O configuration is designed with wiring ergonomics in mind by including removable terminal blocks. The main, easily removable, control board used for all drive frames with six digital IN, two analog IN, one analog OUT, three relay OUT accepts two additional I/O or communication board. In addition, the control board has built-in RS-485 and Ethernet communication.

These drives continue the tradition of robust performance, and raise the bar on features and functionality, ensuring the best solution at the right price.

In addition to the Active Energy Control Algorithm to maximize motor efficiency, the drive boasts an ultra-efficient DC capacitor and power structure to allow less energy consumption, lowering greenhouse gases.

Features and Benefits

Hardware

- Thin metal capacitor design—ultra-efficient drive operation and extended self life (up to five years without reforming)
- Integrated 5% DC link choke with Input surge protection—protects against voltage spikes and provides a clean wave form to the motor
- EMI/RFI filters standard on all drives—meets EMC Category 2 for commercial applications
- Real-time clock—supports calendaring and PLC functionality
- Graphic LCD display and keypad—supports simple menu navigation as well as on-screen diagnostics and troubleshooting
- HAND-OFF-AUTO and drive-bypass selector on keypad—simplifies control
- Standard I/O: 6DI, 2AI, 1AO, 2 Form C RO (NO/NC), 1 Form A RO (NO)—supports requirements for most installations

Contents

Description

	<i>Page</i>
H-Max Drives	
Catalog Number Selection	V6-T2-133
Product Selection	V6-T2-134
Accessories	V6-T2-137
Replacement Parts	V6-T2-137
Technical Data and Specifications	V6-T2-138
Wiring Diagram	V6-T2-139
Dimensions	V6-T2-140
H-Max IntelliPass and IntelliDisconnect Drives	V6-T2-141

Standards and Certifications

Product

- IEC 61800-5-1
- CE
- UL508C
- cUL
- C-Tick Mark
- OSHPD Seismic Certified
- Plenum Rated

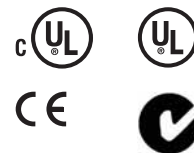

- Onboard RS 485: Modbus, N2, BACnet—meets needs of most communication requirements
- Onboard Ethernet: BACnet/IP, Modbus/TCP—meets needs of most communication requirements
- Two expansion slots—intended to support additional I/O or communication protocols as necessary
- Quick disconnect terminals for I/O connections—supports fast easy installation

Software

- Active energy control—minimizes energy losses in your motor resulting in industry leading energy efficiency for your application
- Quick Start Wizard upon initial power up—supports fast easy installation
- Copy/paste functionality on drive keypad—allows for fast setup of multiple drives
- Pre-programmed I/O—supports fast easy installation for most applications

Catalog Number Selection

H-Max Series Drives

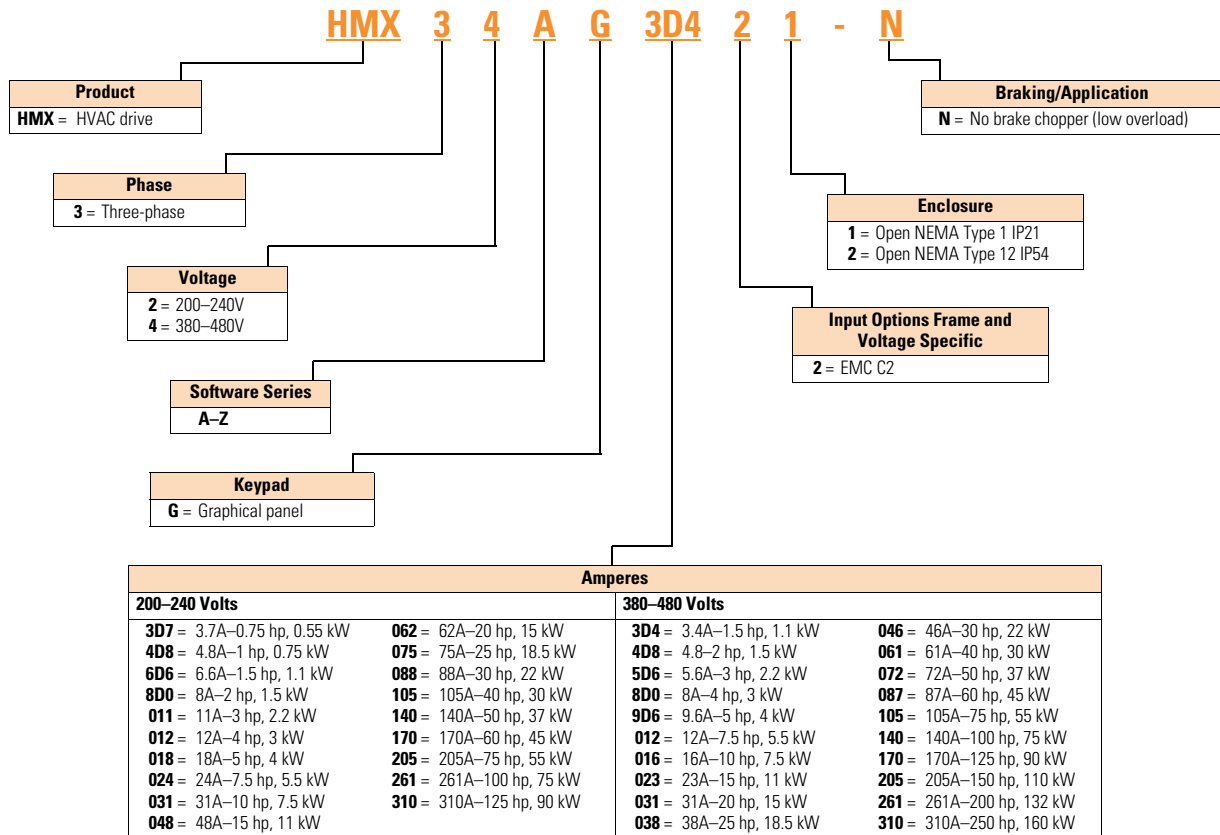
**Notes**

All boards are varnished (conformed coated). Corrosion resistant.

Battery included in all drives for real-time clock.

Keypad kit includes HOA bypass.

Keypad kit includes HOA, back reset for Europe application.

EMI/RFI filters included.

DC link choke included.

2.6

Adjustable Frequency Drives

H-Max Series Drives

Product Selection

H-Max Series Drives—230 Vac

2

NEMA Type 1



NEMA Type 1/IP21

FS Frame Size	Drive Output Current		Assigned Motor Ratings			Catalog Number
	Low Overload Full Load Amps at 40°C	Horsepower	Drive kW 230 Vac/50 Hz	230 Vac NEC Amps ①	Low Overload Full Load Amps at 50°C	
4	3.7	0.75	0.55	3.2	2.6	HMX32AG3D721-N
	4.8	1	0.75	4.2	3.7	HMX32AG4D821-N
	6.6	1.5	1.1	6.6	4.8	HMX32AG6D621-N
	8	2	1.5	6.8	6.6	HMX32AG8D021-N
	11	3	2.2	9.6	8	HMX32AG01121-N
	12.5	4	3	N/A	11	HMX32AG01221-N
5	18	5	4	15.2	12.5	HMX32AG01821-N
	24	7.5	5.5	22	18	HMX32AG02421-N
	31	10	7.5	28	24	HMX32AG03121-N
6	48	15	11	42	31	HMX32AG04821-N
	62	20	15	54	48	HMX32AG06221-N
7	75	25	18.5	68	62	HMX32AG07521-N
	88	30	22	80	75	HMX32AG08821-N
	105	40	30	104	88	HMX32AG10521-N
8	140	50	37	130	105	HMX32AG14021-N
	170	60	45	154	140	HMX32AG17021-N
	205	75	55	192	170	HMX32AG20521-N
9	261	100	75	248	205	HMX32AG26121-N
	310	125	90	N/A	261	HMX32AG31021-N

NEMA Type 12



NEMA Type 12/IP54

FS Frame Size	Drive Output Current		Assigned Motor Ratings			Catalog Number
	Low Overload Full Load Amps at 40°C	Horsepower	Drive kW 230 Vac/50 Hz	230 Vac NEC Amps ①	Low Overload Full Load Amps at 50°C	
4	3.7	0.75	0.55	3.2	2.6	HMX32AG3D722-N
	4.8	1	0.75	4.2	3.7	HMX32AG4D822-N
	6.6	1.5	1.1	6.6	4.8	HMX32AG6D622-N
	8	2	1.5	6.8	6.6	HMX32AG8D022-N
	11	3	2.2	9.6	8	HMX32AG01122-N
	12.5	4	3	N/A	11	HMX32AG01222-N
5	18	5	4	15.2	12	HMX32AG01822-N
	24	7.5	5.5	22	18	HMX32AG02422-N
	31	10	7.5	28	24	HMX32AG03122-N
6	48	15	11	42	31	HMX32AG04822-N
	62	20	15	54	48	HMX32AG06222-N
7	75	25	18.5	68	62	HMX32AG07522-N
	88	30	22	80	75	HMX32AG08822-N
	105	40	30	104	88	HMX32AG10522-N
8	140	50	37	130	105	HMX32AG14022-N
	170	60	45	154	140	HMX32AG17022-N
	205	75	55	192	170	HMX32AG20522-N
9	261	100	75	248	205	HMX32AG26122-N
	310	125	90	N/A	261	HMX32AG31022-N

Note

① For sizing reference.

H-Max Series Drives—480 Vac

NEMA Type 1



NEMA Type 1/IP21

FS Frame Size	Drive Output Current		Assigned Motor Ratings			Catalog Number
	Low Overload Full Load Amps at 40°C	Horsepower	Drive kW 400 Vac/50 Hz	480 Vac NEC Amps ①	Low Overload Full Load Amps at 50°C	
4	3.4	1.5	1.1	2.1	2.6	HMX34AG3D421-N
	4.8	2	1.5	3.4	3.4	HMX34AG4D821-N
	5.6	3	2.2	5.6	4.8	HMX34AG5D621-N
	8.0	4	3.0	N/A	5.6	HMX34AG8D021-N
	9.6	5	4	7.6	8	HMX34AG9D621-N
5	12	7.5	5.5	11	9.6	HMX34AG01221-N
	16	10	7.5	14	12	HMX34AG01621-N
	23	15	11	21	16	HMX34AG02321-N
6	31	20	15	27	23	HMX34AG03121-N
	38	25	18.5	34	31	HMX34AG03821-N
	46	30	22	40	38	HMX34AG04621-N
7	61	40	30	52	46	HMX34AG06121-N
	72	50	37	65	61	HMX34AG07221-N
	87	60	45	77	72	HMX34AG08721-N
8	105	75	55	96	87	HMX34AG10521-N
	140	100	75	124	105	HMX34AG14021-N
	170	125	90	156	140	HMX34AG17021-N
9	205	150	110	180	170	HMX34AG20521-N
	261	200	132	240	205	HMX34AG26121-N
	310	250	160	302	261	HMX34AG31021-N

NEMA Type 12



NEMA Type 12/IP54

FS Frame Size	Drive Output Current		Assigned Motor Ratings			Catalog Number
	Low Overload Full Load Amps at 40°C	Horsepower	Drive kW 400 Vac/50 Hz	480 Vac NEC Amps ①	Low Overload Full Load Amps at 50°C	
4	3.4	1.5	1.1	2.1	2.6	HMX34AG3D422-N
	4.8	2	1.5	3.4	3.4	HMX34AG4D822-N
	5.6	3	2.2	5.6	4.8	HMX34AG5D622-N
	8.0	4	3.0	N/A	5.6	HMX34AG8D022-N
	9.6	5	4	7.6	8	HMX34AG9D622-N
5	12	7.5	5.5	11	9.6	HMX34AG01222-N
	16	10	7.5	14	12	HMX34AG01622-N
	23	15	11	21	16	HMX34AG02322-N
6	31	20	15	27	23	HMX34AG03122-N
	38	25	18.5	34	31	HMX34AG03822-N
	46	30	22	40	38	HMX34AG04622-N
7	61	40	30	52	46	HMX34AG06122-N
	72	50	37	65	61	HMX34AG07222-N
	87	60	45	77	72	HMX34AG08722-N
8	105	75	55	96	87	HMX34AG10522-N
	140	100	75	124	105	HMX34AG14022-N
	170	125	90	156	140	HMX34AG17022-N
9	205	150	110	180	170	HMX34AG20522-N
	261	200	132	240	205	HMX34AG26122-N
	310	250	160	302	261	HMX34AG31022-N

Note

① For sizing reference.

2.6

Adjustable Frequency Drives

H-Max Series Drives

2

Onboard Network Communications

Johnson Controls Metasys N2

H-Max Series provides communication between the drive and a Johnson Controls Metasys™ N2 network. With this connection, the drive can be controlled, monitored and programmed from the Metasys system. N2 can be selected and programmed by the drive keypad.

BACnet

H-Max Series provides communication to BACnet networks. Data transfer is master-slave/token passing (MS/TP) RS-485.

BACnet IP

100Base-T interface.

Modbus TCP

Ethernet based protocol.

Modbus RTU

H-Max Series provides communication to Modbus RTU RS-485 as a slave on a Modbus network. Other communication parameters include an address range from 1–247; a parity of None, Odd or Even; and the stop bit is 1.

H-Max Series Option Board Kits Available for Slot B

The factory issued relay option board can be replaced with the following option

boards to customize the drive for your application needs.

The standard board provides 2 Form C RO (NO/NC) and 1 Form A RO (NO).

Option Boards Mounted in Slot B

Option Kit Description	Option Kit Catalog Number
I/O expander card, 2 RO and thermistor input	Relay Board 2

H-Max Series Option Board Kits Available for Slots D and E

The H-Max Series drives can accommodate a wide selection of expander and adapter option boards to customize the drive for your

application needs. The drive's control unit is designed to accept a total of two option boards.

The H-Max Series factory-installed standard board configuration includes an I/O board and a relay output board.

Option Boards Mounted in Slots D and E

Option Kit Description	Option Kit Catalog Number
6 x DI /DO, each digital input can be individually programmed as digital output	XXM-IO-B1-A
1RO Form C (NO/NC), 1RO Form A (NO), 1 thermistor	XXM-IO-B2-A
1 x AI, 2 x AO (isolated)	XXM-IO-B4-A
3 x RO Form A (NO)	XXM-IO-B5-A
1RO Form A (NO), 5DI 42–240 Vac input	XXM-IO-B9-A
1 x AO, 1 x DO, 1 x RO	XXM-IO-BF-A
LonWorks®	XXM-COM-C4-A

NEMA Type 1 to NEMA Type 12/IP54 Conversion Kit

The NEMA Type 12/IP54 option kit is used to convert a NEMA Type 1 to a NEMA Type 12 drive.

Kit consists of a drive cover, fan kit and plugs.

NEMA Type 12/IP54 Cover

Option Kit Description	Option Kit Catalog Number
FS4-branded N12/IP54 cover with gasket, plastic plug, fans, Eaton logos	FS4-N12KIT
FS5-branded N12/IP54 cover with gasket, plastic plug, fans, Eaton logos	FS5-N12KIT
FS6-branded N12/IP54 cover with gasket, plastic plug, fans, Eaton logos	FS6-N12KIT

Accessories

Flange Kits

The flange kit is used when the power section heat sink is mounted through the back panel of an enclosure.

Flange Kit NEMA Type 12/IP54

Includes flange, mounting brackets, NEMA Type 12 fan components, air shroud screws and plugs.

Frames FS4–FS7 ^{①②}

Description	Catalog Number
NEMA Type 12/IP54	
FS4 N12/IP54 flange kit (mounting N1 drive into N12 enclosure)	FS4-Flange-N12KIT
FS5 N12/IP54 flange kit (mounting N1 drive into N12 enclosure)	FS5-Flange-N12KIT
FS6 N12/IP54 flange kit (mounting N1 drive into N12 enclosure)	FS6-Flange-N12KIT
FS7 N12/IP54 flange kit (mounting N1 drive into N12 enclosure)	FS7-Flange-N12KIT

Keypad Accessories

Remote Mounting Keypad Kit

Frames FS4–FS9

Description	Catalog Number
Remote mounting keypad kit—bezel and cable	OPTRMT-BP-HMAX

Drive Demo

H-Max Series Drive Demo

Demos and Power Supply

Description	Catalog Number
H-Max Series bypass demo	H-MAX-BYPASS-DEMO
Hand-held 24V auxiliary power supply—used to supply power to the control module in order to perform keypad programming before the drive is connected to line voltage	9000XAUX24V

Notes

- ① For installation of a NEMA Type 1 drive into a NEMA Type 12 oversized enclosure.
- ② Frame size 8 and 9 must be ordered from the factory as a flange mount unit.

Replacement Parts

Control Board/Keypad

Description	Current Catalog Number
H-Max Series graphic bypass, HOA	KeypadbypassHOA
H-Max Series graphic back, HOA	KeypadbackHOA

PC Cable

Description	Catalog Number
Remote download USB to RJ-45 cable with software driver disk	REM-USB-Down

Replacement Relay Board in Slot B

Description	Catalog Number
Replacement relay board qty 2 Form C relay, qty 1 Form A relay	Relay board 1

Main Fan

Description	Catalog Number
FS4 main fan	FS4-Main Fan
FS5 main fan	FS5-Main Fan
FS6 main fan	FS6-Main Fan
FS7 main fan	FS7-Main Fan

Internal Fan

Description	Catalog Number
FS4 internal fan (IP54/NEMA 12)	FS4-Internal Fan
FS5 internal fan (IP54/NEMA 12)	FS5-Internal Fan
FS6 internal fan (IP54/NEMA 12)	FS6-Internal Fan
FS7 internal fan (IP54/NEMA 12)	FS7-Internal Fan

Technical Data and Specifications

2

H-Max Series Drives

Description	Specification
Input Ratings	
Input voltage (V_{in})	200–240 Vac, 380–480 Vac, $-10\%/+10\%$
Input frequency (f_{in})	50/60 Hz (variation up to 47–66 Hz)
Connection to power	Once per minute or less (typical operation)
Short-circuit withstand rating	100 kAIC
Output Ratings	
Output voltage	0 to V_{in}/U_{in} line voltage in
Continuous output current	Ambient temperature max. 104°F (40°C)
I_L overload	1.1 x I_L (1 min./10 min.)
Overload current	110% (1 min./10 min.)
Initial output current	150% for two seconds
Output frequency	0 to 320 Hz
Frequency resolution	0.01 Hz
Control Characteristics	
Control method	Frequency control (V/f) open loop sensorless vector control
Switching frequency	1–310 amps FS4–9: default 6 kHz
Frequency reference	Analog input: Resolution 0.1% (10-bit), accuracy $\pm 1\%$ Panel reference: Resolution 0.01 Hz
Field weakening point	8 to 320 Hz
Acceleration time	0.1 to 3000 seconds
Deceleration time	0.1 to 3000 seconds
Braking torque	DC brake: 30% x T_n
Ambient Conditions	
Ambient operating temperature	FS4–FS9: 14°F (–10°C), no frost to 104°F (40°C) (Drive can operate at 122°F (50°C), see Pages V6-T2-134 and V6-T2-135)
Storage temperature	–40° to 158°F (–40° to 70°C)
Relative humidity	0 to 95% RH, noncondensing, non-corrosive, no dripping water
Air quality	Chemical vapors: IEC 60721-3-3, unit in operation, Class 3C2; Mechanical particles: IEC 60721-3-3, unit in operation, Class 3S2
Altitude	100% load capacity (no derating) up to 3280 ft (1000m); 1% derating for each 328 ft (100m) above 3280 ft (1000m); max. 9842 ft (3000m); 380–480V
Vibration	FS4–FS9: EN 61800-5-1, EN 60068-2-6; 5 to 150 Hz, displacement amplitude 1 mm (peak) at 5 to 15.8 Hz, max. acceleration amplitude 1G at 15.8 to 150 Hz
Shock	EN 61800-5-1, EN 60068-2-27 UPS Drop test (for applicable UPS weights) Storage and shipping: max. 15G, 11 ms (in package)
Enclosure class	NEMA Type 1/IP21 or NEMA Type 12/IP54 (keypad required for IP54/Type 12)
Standards	
EMC	Immunity: Fulfills all EMC immunity requirements; Emissions: EN 61800-3, LEVEL H (EMC C2)
Emissions	EMC level dependent— +EMC 2: EN61800-3 (2004) Category C2 Delivered with Class C2 EMC filtering as default.

Description	Specification
Control Connections	
Analog input voltage	0 to 10V, R = 200 kohms differential Resolution 0.1%; Accuracy $\pm 1\%$ DIP switch selection (voltage/current)
Analog input current	0(4) to 20 mA; R_i –250 ohms differential
Digital inputs (6)	Positive or negative logic; 18 to 30 Vdc
Auxiliary voltage	+24V $\pm 10\%$, max. 250 mA
Output reference voltage	+10V +3%, max. load 10 mA
Analog output	0–10V, 0(4) to 20 mA; R_L max. 500 ohms; Resolution 10 bit; Accuracy $\pm 2\%$ DIP switch selection (voltage/current)
Relay outputs	3 programmable, 2 Form C, 1 Form A relay outputs Switching capacity: 24 Vdc/8A, 250 Vac/8A, 125 Vdc/0.4A
Hard wire jumper	Between terminal 6 and 10 factory default
DIP switch setting default	RS-485 = off A01 = current A12 = current A11 = voltage
Protections	
Overcurrent protection	Yes
Overvoltage protection	Yes
DC bus regulation anti-trip	Yes (accelerates or decelerates the load)
Undervoltage protection	Yes
Earth fault protection	Yes (in case of earth fault in motor or motor cable, only the frequency converter is protected)
Input phase supervision	Yes (trips if any of the input phases are missing)
Motor phase supervision	Yes (trips if any of the output phases are missing)
Overtemperature protection	Yes
Motor overload protection	Yes
Motor stall protection	Yes
Motor underload protection	Yes
Short-circuit protection	Yes
Surge protection	Yes (varistor input)
Conformed coated (varnished) boards	Yes (prevents corrosion)

Wiring Diagram

Control Input/Output, PID Application

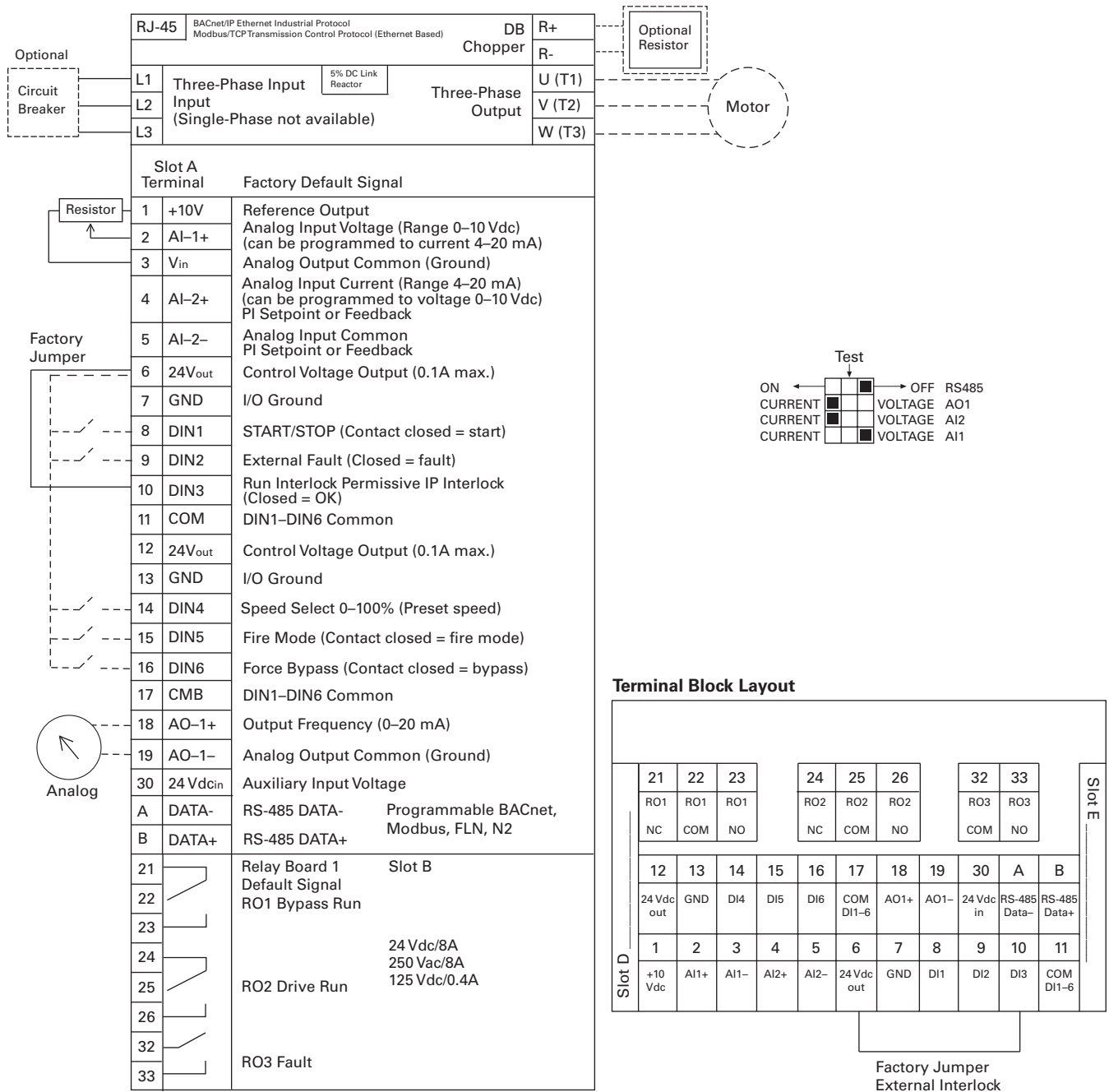
**Standards**

- Digital inputs D1–D6, relay out, analog in/out are freely programmed
- The user can assign a single input to multiple functions

Includes

- Six digital input
- Two analog input
- One analog output
- Three relay output
- RS-485
- Ethernet (BACnet and Modbus)

Reliability

- Pretested components
- Conformal coated (varnished) boards
- 40°C rated
- 110% overload for one minute
- Eaton Electrical Services & Systems national network of AF drive specialists

2.6

Adjustable Frequency Drives

H-Max Series Drives

Dimensions

Approximate Dimensions in Inches (mm)

2

H-Max Series Frames FS4-FS7

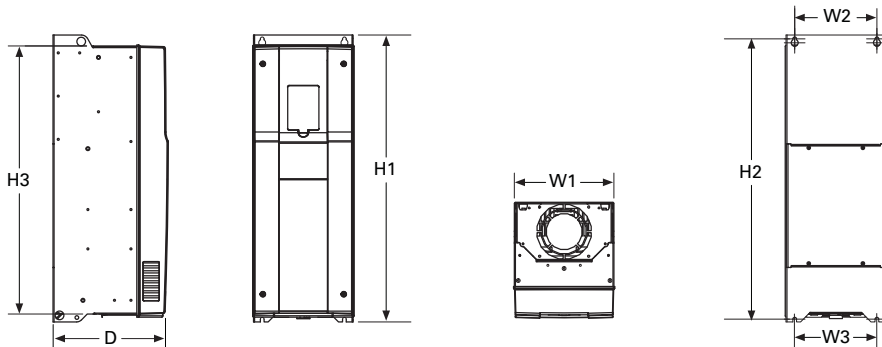

Voltage	hp	kW	Amps	D	H1	Hole Center-to-Center H2	H3	W1	W2	W3	Weight in Lbs (kg)
FS4											
230 Vac	0.75-4	0.55-3.0	3.7-12.5	7.77 (197.3)	12.89 (327.5)	12.32 (313.0)	11.22 (285.0)	5.04 (128.0)	3.94 (100.0)	3.94 (100.0)	13.2 (6)
480 Vac	1.5-7.5	1.1-5.5	3.4-12								
FS5											
230 Vac	5-10	4-7.5	18-31	8.73 (221.6)	16.50 (419.0)	15.98 (406.0)	15.04 (382.0)	5.67 (144.0)	4.53 (115.0)	3.94 (100.0)	22.0 (10)
480 Vac	10-20	7.5-15	16-31								
FS6											
230 Vac	15-20	11-15	48-62	9.29 (236.0)	21.93 (557.0)	21.28 (540.5)	20.24 (514.0)	7.68 (195.0)	5.83 (148.0)	5.83 (148.0)	44.1 (20)
480 Vac	25-40	18.5-30	38-61								
FS7											
230 Vac	25-30	18.5-30	75-105	10.49 (266.5)	25.98 (660.0)	25.39 (645.0)	24.29 (617.0)	9.06 (230.0)	7.48 (190.0)	7.48 (190.0)	82.6 (37.5)
480 Vac	50-75	37-55	72-105								

H-Max Series Frames FS8 and FS9

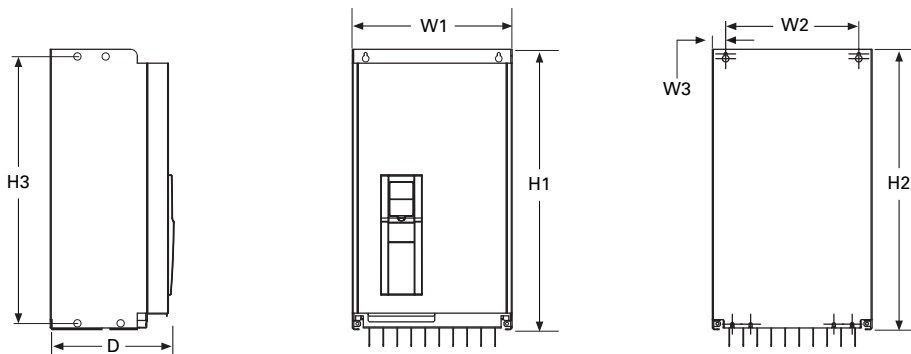

Voltage	hp	kW	Amps	D	H1	Hole Center-to-Center H2	H3	W1	W2	W3	Weight in Lbs (kg)
FS8											
230 Vac	50-75	37-55	140-205	13.76 (349.6)	38.02 (965.7)	37.26 (946.4)	37.26 (946.4)	11.42 (290.1)	9.29 (236.0)	1.42 (36.0)	154.3 (70)
480 Vac	100-150	75-110									
FS9											
230 Vac	100-120	75-90	261-310	14.63 (371.6)	33.09 (890.4)	31.89 (810.0)	31.89 (810.0)	18.90 (480.0)	15.75 (400.0)	1.57 (40.0)	238.1 (108)
480 Vac	200-250	132-160									

Note: For flange dimension, please reference User Manual.

H-Max IntelliPass and IntelliDisconnect Drives**Contents**

Description	Page
H-Max Drives	V6-T2-132
H-Max IntelliPass and IntelliDisconnect Drives	
Catalog Number Selection	V6-T2-142
Product Selection	V6-T2-143
Technical Data and Specifications	V6-T2-151
Wiring Diagrams	V6-T2-152
Dimensions	V6-T2-154

H-Max IntelliPass and IntelliDisconnect Drives**Product Description**

The IntelliPass electronic bypass is a two or optional three contactor design using a 24 Vdc **XT** Series contactor with an optional manual override switch that allows the unit to run in bypass without the H-Max Series drive.

The IntelliPass software parameters utilize engineering units common to the HVAC industry. Onboard startup wizard guarantees flawless commissioning with plug-and-play screen entry. Available in NEMA/UL Type 1, Type 12 and Type 3R with optional pre-engineered operator devices to meet all customized specification requirements.

The IntelliPass construction features allow for easy installation, reliable operation and serviceability with additional onboard wire space, and removable conduit plates with knockouts.

Features and Benefits

Industry-leading energy saving solution—uses the Eaton H-Max drive with Active Energy Control algorithm.

Built to be as tough as the application—Eaton's robust design boasts an industrial grade enclosure and industry proven components.

- Industrial Power Supply
- **XT** Contactors
- 22 mm Pilot Devices

Designed with Our Customers in Mind

- Removable top and bottom entry panels
- Door-mounted graphic display and keypad
- Easily accessible connection terminals with removable I/O terminal connections

Engineered Product Solution

- The Eaton H-Max IntelliPass and IntelliDisconnect products are available with a variety of factory tested and certified options meeting or exceeding UL508C requirements

Standards and Certifications**Product**

- IEC 61800-5-1
- UL508C
- cUL
- OSHPD Seismic Certified



2.6

Adjustable Frequency Drives

H-Max Series Drives

Catalog Number Selection

2

H-Max Series IntelliPass and IntelliDisconnect Drives

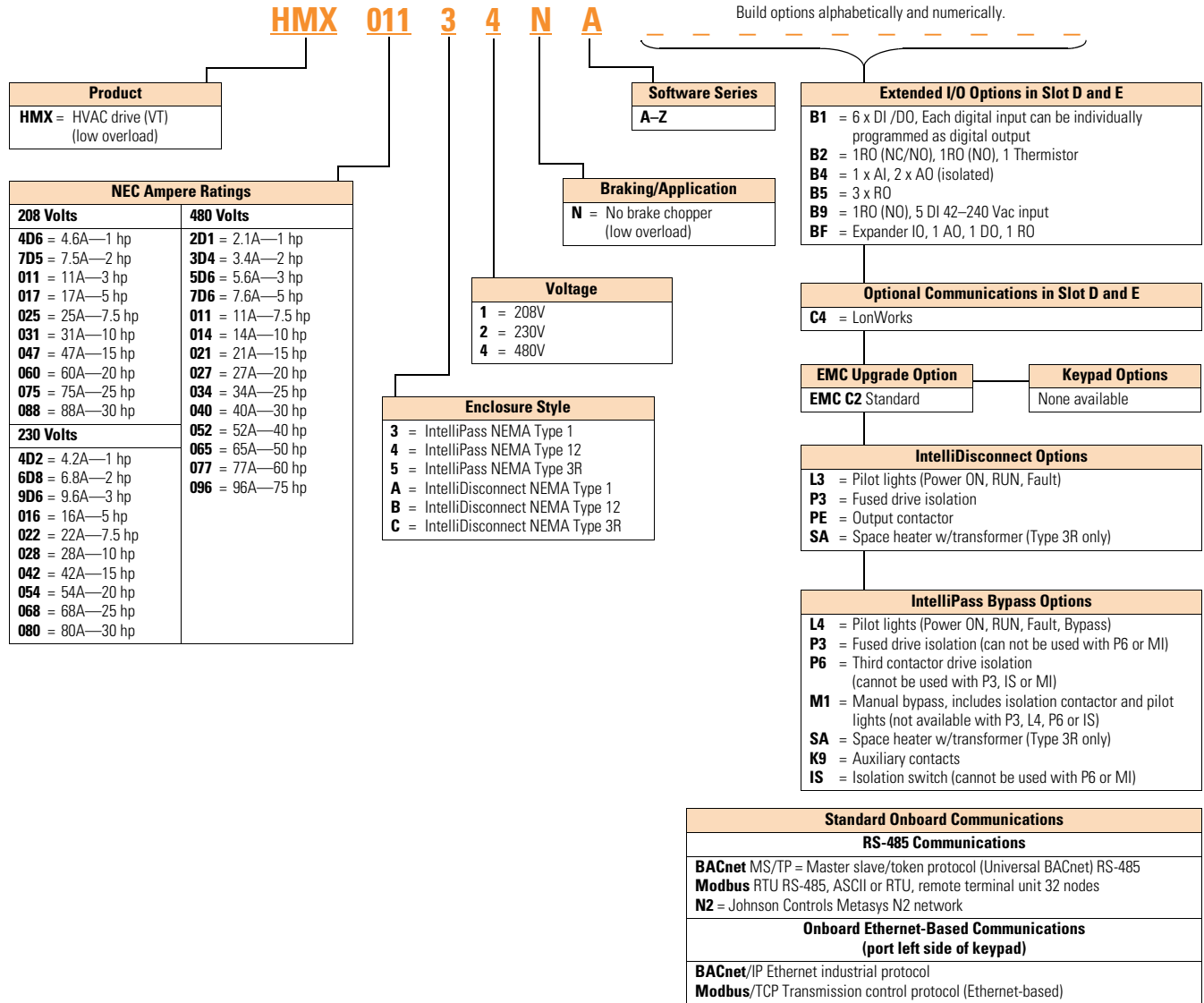

Notes

- IntelliPass—two contactor electronic bypass standard.
- All boards are varnished. Corrosion resistant.
- Battery included in all drives for real-time clock. Three year lifetime.
- Keypad kit includes HOA bypass.
- EMI/RFI filters included.
- DC link choke included.

Product Selection

H-Max Series IntelliPass NEMA Type 1—Two Contactor Bypass Standard

HMX_



208 Vac

FS Frame Size	Horsepower	Drive Rated NEC Amps	Catalog Number
4	1	4.6	HMX4D631NA
	2	7.5	HMX7D531NA
	3	10.6	HMX01131NA
5	5	16.7	HMX01731NA
	7.5	24.2	HMX02531NA
	10	30.8	HMX03131NA
6	15	46.2	HMX04731NA
	20	59.4	HMX06031NA
7	25	74.9	HMX07531NA
	30	88	HMX08831NA

230 Vac

FS Frame Size	Horsepower	Drive Rated NEC Amps	Catalog Number
4	1	4.2	HMX4D232NA
	2	6.8	HMX6D832NA
	3	9.6	HMX9D632NA
5	5	15.2	HMX01632NA
	7.5	22	HMX02232NA
	10	28	HMX02832NA
6	15	42	HMX04232NA
	20	54	HMX05432NA
7	25	68	HMX06832NA
	30	80	HMX08032NA

480 Vac

FS Frame Size	Horsepower	Drive Rated NEC Amps	Catalog Number
4	1	2.1	HMX2D134NA
	2	3.4	HMX3D434NA
	3	5.6	HMX5D634NA
	5	7.6	HMX7D634NA
	7.5	11	HMX01134NA
5	10	14	HMX01434NA
	15	21	HMX02134NA
	20	27	HMX02734NA
6	25	34	HMX03434NA
	30	40	HMX04034NA
	40	52	HMX05234NA
7	50	65	HMX06534NA
	60	77	HMX07734NA
	75	96	HMX09634NA

NotesFor Wiring Diagrams, see **Page V6-T2-153**.For NEMA 12 or 3R enclosures, see Catalog Number Selection on **Page V6-T2-142**.

Call Technical Support for NEMA 3R specifics. Enclosure size and weight differ from NEMA 1 and 12 products.

2.6

Adjustable Frequency Drives

H-Max Series Drives

H-Max Series IntelliPass NEMA Type 12—Two Contactor Bypass Standard

2

HMX_



208 Vac

FS Frame Size	Horsepower	Drive Rated NEC Amps	Catalog Number
4	1	4.6	HMX4D641NA
	2	7.5	HMX7D541NA
	3	10.6	HMX01141NA
5	5	16.7	HMX01741NA
	7.5	24.2	HMX02541NA
	10	30.8	HMX03141NA
6	15	46.2	HMX04741NA
	20	59.4	HMX06041NA
7	25	74.9	HMX07541NA
	30	88	HMX08841NA

230 Vac

FS Frame Size	Horsepower	Drive Rated NEC Amps	Catalog Number
4	1	4.2	HMX4D242NA
	2	6.8	HMX6D842NA
	3	9.6	HMX9D642NA
5	5	15.2	HMX01642NA
	7.5	22	HMX02242NA
	10	28	HMX02842NA
6	15	42	HMX04242NA
	20	54	HMX05442NA
7	25	68	HMX06842NA
	30	80	HMX08042NA

480 Vac

FS Frame Size	Horsepower	Drive Rated NEC Amps	Catalog Number
4	1	2.1	HMX2D144NA
	2	3.4	HMX3D444NA
	3	5.6	HMX5D644NA
	5	7.6	HMX7D644NA
	7.5	11	HMX01144NA
5	10	14	HMX01444NA
	15	21	HMX02144NA
	20	27	HMX02744NA
6	25	34	HMX03444NA
	30	40	HMX04044NA
	40	52	HMX05244NA
7	50	65	HMX06544NA
	60	77	HMX07744NA
	75	96	HMX09644NA

Notes

For Wiring Diagrams, see **Page V6-T2-153**.

For NEMA 12 or 3R enclosures, see Catalog Number Selection on **Page V6-T2-142**.

Call Technical Support for NEMA 3R specifics. Enclosure size and weight differ from NEMA 1 and 12 products.

H-Max Series IntelliPass NEMA Type 3R—Two Contactor Bypass Standard

HMX_

**208 Vac**

FS Frame Size	Horsepower	Drive Rated NEC Amps	Catalog Number
4	1	4.6	HMX4D651NA
	2	7.5	HMX7D551NA
	3	10.6	HMX01151NA
5	5	16.7	HMX01751NA
	7.5	24.2	HMX02551NA
	10	30.8	HMX03151NA
6	15	46.2	HMX04751NA
	20	59.4	HMX06051NA
7	25	74.9	HMX07551NA
	30	88	HMX08851NA

230 Vac

FS Frame Size	Horsepower	Drive Rated NEC Amps	Catalog Number
4	1	4.2	HMX4D252NA
	2	6.8	HMX6D852NA
	3	9.6	HMX9D652NA
5	5	15.2	HMX01652NA
	7.5	22	HMX02252NA
	10	28	HMX02852NA
6	15	42	HMX04252NA
	20	54	HMX05452NA
7	25	68	HMX06852NA
	30	80	HMX08052NA

480 Vac

FS Frame Size	Horsepower	Drive Rated NEC Amps	Catalog Number
4	1	2.1	HMX2D154NA
	2	3.4	HMX3D454NA
	3	5.6	HMX5D654NA
	5	7.6	HMX7D654NA
	7.5	11	HMX01154NA
5	10	14	HMX01454NA
	15	21	HMX02154NA
	20	27	HMX02754NA
6	25	34	HMX03454NA
	30	40	HMX04054NA
	40	52	HMX05254NA
7	50	65	HMX06554NA
	60	77	HMX07754NA
	75	96	HMX09654NA

NotesFor Wiring Diagrams, see **Page V6-T2-153**.For NEMA 12 or 3R enclosures, see Catalog Number Selection on **Page V6-T2-142**.

Call Technical Support for NEMA 3R specifics. Enclosure size and weight differ from NEMA 1 and 12 products.

2.6

Adjustable Frequency Drives

H-Max Series Drives

H-Max Series IntelliDisconnect NEMA Type 1—Main Disconnect Standard

2

HMX_



208 Vac

FS Frame Size	Horsepower	Drive Rated NEC Amps	Catalog Number
4	1	4.6	HMX4D6A1NA
	2	7.5	HMX7D5A1NA
	3	11	HMX011A1NA
5	5	17	HMX017A1NA
	7.5	25	HMX025A1NA
	10	31	HMX031A1NA
6	15	47	HMX047A1NA
	20	60	HMX060A1NA
7	25	75	HMX075A1NA
	30	88	HMX088A1NA

230 Vac

FS Frame Size	Horsepower	Drive Rated NEC Amps	Catalog Number
4	1	4.2	HMX4D2A2NA
	2	6.8	HMX6D8A2NA
	3	9.6	HMX9D6A2NA
5	5	15.2	HMX016A2NA
	7.5	22	HMX022A2NA
	10	28	HMX028A2NA
6	15	42	HMX042A2NA
	20	54	HMX054A2NA
7	25	68	HMX068A2NA
	30	80	HMX080A2NA

480 Vac

FS Frame Size	Horsepower	Drive Rated NEC Amps	Catalog Number
4	1	2.1	HMX2D1A4NA
	2	3.4	HMX3D4A4NA
	3	5.6	HMX5D6A4NA
	5	7.6	HMX7D6A4NA
	7.5	11	HMX011A4NA
5	10	14	HMX014A4NA
	15	21	HMX021A4NA
	20	27	HMX027A4NA
6	25	34	HMX034A4NA
	30	40	HMX040A4NA
	40	52	HMX052A4NA
7	50	65	HMX065A4NA
	60	77	HMX077A4NA
	75	96	HMX096A4NA

Notes

For Wiring Diagrams, see **Page V6-T2-153**.

For NEMA 12 or 3R enclosures, see Catalog Number Selection on **Page V6-T2-142**.

Call Technical Support for NEMA 3R specifics. Enclosure size and weight differ from NEMA 1 and 12 products.

H-Max Series IntelliDisconnect NEMA Type 12—Main Disconnect Standard

HMX

**208 Vac**

FS Frame Size	Horsepower	Drive Rated NEC Amps	Catalog Number
4	1	4.6	HMX4D6B1NA
	2	7.5	HMX7D5B1NA
	3	11	HMX011B1NA
5	5	17	HMX017B1NA
	7.5	25	HMX025B1NA
	10	31	HMX031B1NA
6	15	47	HMX047B1NA
	20	60	HMX060B1NA
7	25	75	HMX075B1NA
	30	88	HMX088B1NA

230 Vac

FS Frame Size	Horsepower	Drive Rated NEC Amps	Catalog Number
4	1	4.2	HMX4D2B2NA
	2	6.8	HMX6D8B2NA
	3	9.6	HMX9D6B2NA
5	5	15.2	HMX016B2NA
	7.5	22	HMX022B2NA
	10	28	HMX028B2NA
6	15	42	HMX042B2NA
	20	54	HMX054B2NA
7	25	68	HMX068B2NA
	30	80	HMX080B2NA

480 Vac

FS Frame Size	Horsepower	Drive Rated NEC Amps	Catalog Number
4	1	2.1	HMX2D1B4NA
	2	3.4	HMX3D4B4NA
	3	5.6	HMX5D6B4NA
	5	7.6	HMX7D6B4NA
	7.5	11	HMX011B4NA
5	10	14	HMX014B4NA
	15	21	HMX021B4NA
	20	27	HMX027B4NA
6	25	34	HMX034B4NA
	30	40	HMX040B4NA
	40	52	HMX052B4NA
7	50	65	HMX065B4NA
	60	77	HMX077B4NA
	75	96	HMX096B4NA

NotesFor Wiring Diagrams, see **Page V6-T2-153**.For NEMA 12 or 3R enclosures, see Catalog Number Selection on **Page V6-T2-142**.

Call Technical Support for NEMA 3R specifics. Enclosure size and weight differ from NEMA 1 and 12 products.

2.6

Adjustable Frequency Drives

H-Max Series Drives

H-Max Series IntelliDisconnect NEMA Type 3R—Main Disconnect Standard

2

HMX



208 Vac

FS Frame Size	Horsepower	Drive Rated NEC Amps	Catalog Number
4	1	4.6	HMX4D6C1NA
	2	7.5	HMX7D5C1NA
	3	11	HMX011C1NA
5	5	17	HMX017C1NA
	7.5	25	HMX025C1NA
	10	31	HMX031C1NA
6	15	47	HMX047C1NA
	20	60	HMX060C1NA
7	25	75	HMX075C1NA
	30	88	HMX088C1NA

230 Vac

FS Frame Size	Horsepower	Drive Rated NEC Amps	Catalog Number
4	1	4.2	HMX4D2C2NA
	2	6.8	HMX6D8C2NA
	3	9.6	HMX9D6C2NA
5	5	15.2	HMX016C2NA
	7.5	22	HMX022C2NA
	10	28	HMX028C2NA
6	15	42	HMX042C2NA
	20	54	HMX054C2NA
7	25	68	HMX068C2NA
	30	80	HMX080C2NA

480 Vac

FS Frame Size	Horsepower	Drive Rated NEC Amps	Catalog Number
4	1	2.1	HMX2D1C4NA
	2	3.4	HMX3D4C4NA
	3	5.6	HMX5D6C4NA
	5	7.6	HMX7D6C4NA
	7.5	11	HMX011C4NA
5	10	14	HMX014C4NA
	15	21	HMX021C4NA
	20	27	HMX027C4NA
6	25	34	HMX034C4NA
	30	40	HMX040C4NA
	40	52	HMX052C4NA
7	50	65	HMX065C4NA
	60	77	HMX077C4NA
	75	96	HMX096C4NA

Notes

For Wiring Diagrams, see **Page V6-T2-153**.

For NEMA 12 or 3R enclosures, see Catalog Number Selection on **Page V6-T2-142**.

Call Technical Support for NEMA 3R specifics. Enclosure size and weight differ from NEMA 1 and 12 products.

Onboard Network Communications**Johnson Controls
Metasys N2**

H-Max Series provides communication between the drive and a Johnson Controls Metasys™ N2 network. With this connection, the drive can be controlled, monitored and programmed from the Metasys system. N2 can be selected and programmed by the drive keypad.

BACnet

H-Max Series provides communication to BACnet networks. Data transfer is master-slave/token passing (MS/TP) RS-485.

BACnet IP

100Base-T interface.

Modbus TCP

Ethernet based protocol.

Modbus RTU

H-Max Series provides communication to Modbus RTU RS-485 as a slave on a Modbus network. Other communication parameters include an address range from 1 to 247; a parity of None, Odd or Even; and the stop bit is 1.

H-Max Series Option Board Kits Available for Slots D and E

The H-Max Series drives can accommodate a wide selection of expander and adapter option boards to customize the drive for your

application needs. The drive's control unit is designed to accept a total of two option boards.

The H-Max Series factory-installed standard board configuration includes an I/O board and a relay output board.

Option Boards Mounted in Slots D and E

Option Kit Description	Option Kit Catalog Number
6 x DI /DO, each digital input can be individually programmed as digital output	XXM-IO-B1-A
1RO Form C (NO/NC), 1RO Form A (NO), 1 thermistor	XXM-IO-B2-A
1 x AI, 2 x AO (isolated)	XXM-IO-B4-A
3 x RO Form A (NO)	XXM-IO-B5-A
1RO Form A (NO), 5DI 42–240 Vac input	XXM-IO-B9-A
LonWorks	XXM-COM-C4-A
1 x AO, 1 x DO, 1 x RO	XXM-IO-BF-A

Extended I/O Options in Slot D and E

2

Description	Suffix Number
6 x DI /DO, Each digital input can be individually programmed as digital output	B1
1RO (NC/NO), 1RO (NO), 1 Thermistor	B2
1 x AI, 2 x AO (isolated)	B4
3 x RO	B5
1RO (NO), 5 DI 42–240 Vac input	B9
Expander IO, 1 AO, 1 DO, 1 RO	BF

Optional Communications in Slot D and E

Description	Suffix Number
LonWorks	C4

IntelliDisconnect Options

Description	Suffix Number
Pilot lights (Power ON, RUN, Fault)	L3
Fused drive isolation (cannot be used with PE)	P3
Output contactor (cannot be used with P3)	PE
Space heater w/transformer (Type 3R only)	SA

IntelliPass Bypass Options

Description	Suffix Number
Pilot lights (Power ON, RUN, Fault)	L4
Fused drive isolation (can not be used with P6)	P3
Third contactor drive isolation (cannot be used with P3 or IS)	P6
Manual bypass switch located on front door	M1
Space heater w/transformer (Type 3R only)	SA
Auxiliary contacts	K9
Isolation switch	IS

Standard Onboard Communications

Description	Suffix Number
RS-485 Communications	
BACnet MS/TP = Master slave/token protocol (Universal BACnet) RS-485	BACnet
Modbus RTU RS-485, ASCII or RTU, remote terminal unit 32 nodes	Modbus
Johnson Controls Metasys N2 network	N2
Onboard Ethernet-Based Communications (port left side of keypad)	
BACnet/IP Ethernet industrial protocol	BACnet
Modbus/TCP Transmission control protocol (Ethernet-based)	Modbus

Technical Data and Specifications

Primary Design Features

Description	IntelliPass	IntelliDisconnect
CB MMP	Standard	Standard
2 contactor bypass	Standard	N/A
Electrical interlock	Standard	N/A
Third contactor (isolation)	Optional	N/A

H-Max Series Drives

Description	Specification
Input Ratings	
Input voltage (V_{in})	208, 230, 480 Vac, -10%/+10%
Input frequency (f_{in})	50/60 Hz (variation up to 47–66 Hz)
Connection to power	Once per minute or less (typical operation)
Short-circuit withstand rating	65 kAIC combination
Output Ratings	
Output voltage	0 to V_{in}/U_{in} line voltage in
Continuous output current	Ambient temperature max. 104°F (40°C)
I_L overload	1.1 x I_L (1 min./10 min.)
Overload current	110% (1 min./10 min.)
Initial output current	150% for two seconds
Output frequency	0 to 320 Hz
Frequency resolution	0.01 Hz
Control Characteristics	
Control method	Frequency control (V/f) open loop sensorless vector control
Switching frequency	1–310 amps; adjustable with parameter 2.6.9 FS4–FS7: default 6 kHz
Frequency reference	Analog input: Resolution 0.1% (10-bit), accuracy $\pm 1\%$ Panel reference: Resolution 0.01 Hz
Field weakening point	8 to 320 Hz
Acceleration time	0.1 to 3000 seconds
Deceleration time	0.1 to 3000 seconds
Braking torque	DC brake: 30% x T_n
Ambient Conditions	
Ambient operating temperature	FS4–FS7: 14°F (–10°C), no frost to 104°F (40°C) (Drive can operate at 122°F (50°C))
Storage temperature	–40° to 158°F (–40° to 70°C)
Relative humidity	0 to 95% RH, noncondensing, non-corrosive, no dripping water
Air quality	Chemical vapors: IEC 60721-3-3, unit in operation, Class 3C2; Mechanical particles: IEC 60721-3-3, unit in operation, Class 3S2
Altitude	100% load capacity (no derating) up to 3280 ft (1000m); 1% derating for each 328 ft (100m) above 3280 ft (1000m); max. 9842 ft (3000m); 380–480V
Vibration	FS4–FS7: IEC 60068-2-6, 10–150 Hz Displacement amplitude = 1 mm peak-to-peak from 10–15.8 Hz Max. acceleration amplitude = 1G peak from 15.8–150 Hz
Shock	FS4–FS7: IEC 60068-2-27, 15G peak acceleration at 11 ms duration, 1/2-sine. ISTA 1A Certified
Enclosure class	NEMA Type 1/IP21 or NEMA Type 12/IP54 (keypad required for IP54/Type 12)

Description	IntelliPass	IntelliDisconnect
Isolation switch	Optional	N/A
Top entry (power)	Standard	Standard
Bottom entry (power)	Standard	Standard
Output contactor	Standard	Optional

Description	Specification
Standards	
EMC	Immunity: Fulfills all EMC immunity requirements; Emissions: EN 61800-3, LEVEL H (EMC C2)
Emissions	EMC level dependent— +EMC 2: EN61800-3 (2004) Category C2 Delivered with Class C2 EMC filtering as default.
Control Connections	
Analog input voltage	0 to 10V, R = 200 kohms differential Resolution 0.1%; Accuracy $\pm 1\%$ DIP switch selection (voltage/current)
Analog input current	0(4) to 20 mA; R_i –250 ohms differential
Digital inputs (6)	Positive or negative logic; 18 to 30 Vdc
Auxiliary voltage	+24V $\pm 10\%$, max. 250 mA
Output reference voltage	+10V +3%, max. load 10 mA
Analog output	0–10V, 0(4) to 20 mA; R_L max. 500 ohms; Resolution 10 bit; Accuracy $\pm 2\%$; DIP switch selection (voltage/current)
Relay outputs	3 programmable, 2 Form C, 1 Form A relay outputs Switching capacity: 24 Vdc/8A, 250 Vac/8A, 125 Vdc/0.4A
Hard wire jumper	Between terminal 6 and 10 factory default
DIP switch setting default	RS-485 = off A01 = current A12 = current A11 = voltage
Protections	
Overcurrent protection	Yes
Overvoltage protection	Yes
DC bus regulation anti-trip	Yes (accelerates or decelerates the load)
Undervoltage protection	Yes
Earth fault protection	Yes (in case of earth fault in motor or motor cable, only the frequency converter is protected)
Input phase supervision	Yes (trips if any of the input phases are missing)
Motor phase supervision	Yes (trips if any of the output phases are missing)
Overtemperature protection	Yes
Motor overload protection	Yes
Motor stall protection	Yes
Motor underload protection	Yes
Short-circuit protection	Yes
Surge protection	Yes (varistor input)
Conformed coated (varnished) board	Yes (prevents corrosion)

Wiring Diagrams

Control Input/Output, PID Application

2

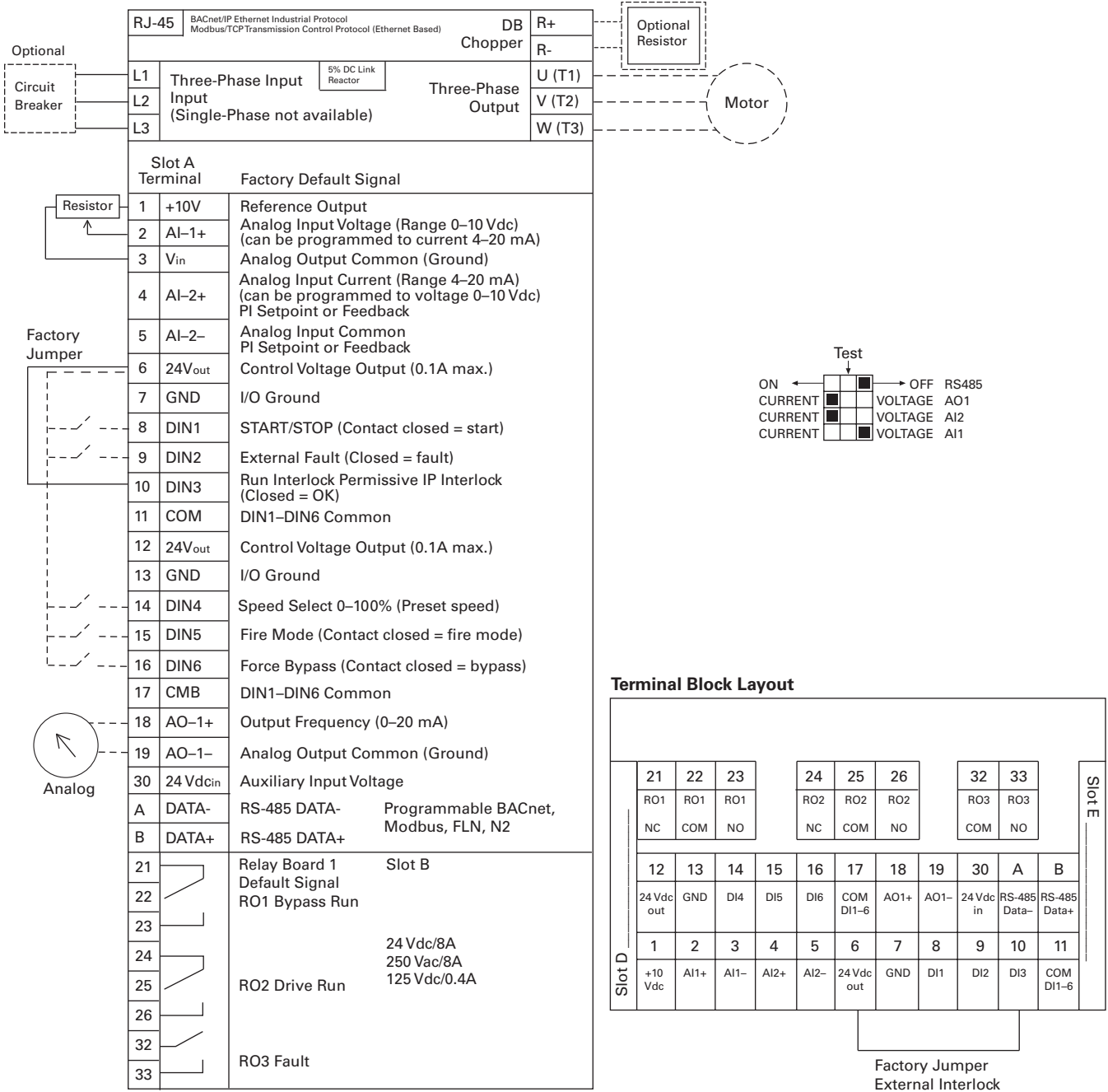

Standards

- Digital inputs D1–D6, relay out, analog in/out are freely programmed
- The user can assign a single input to multiple functions

Includes

- Six digital input
- Two analog input
- One analog output
- Three relay output
- RS-485
- Ethernet

Reliability

- Pretested components
- Conformal coated (varnished) boards
- 40°C rated
- 110% overload for one minute
- Eaton Electrical Services & Systems national network of AF drive specialists

H-Max Series IntelliPass

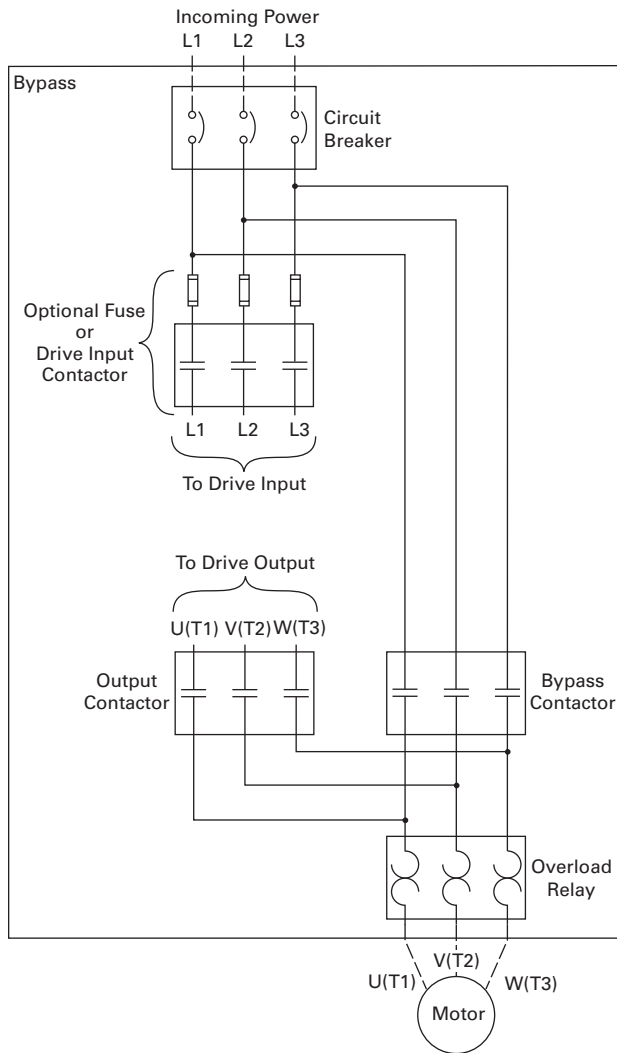

H-Max Series IntelliDisconnect Power Wiring

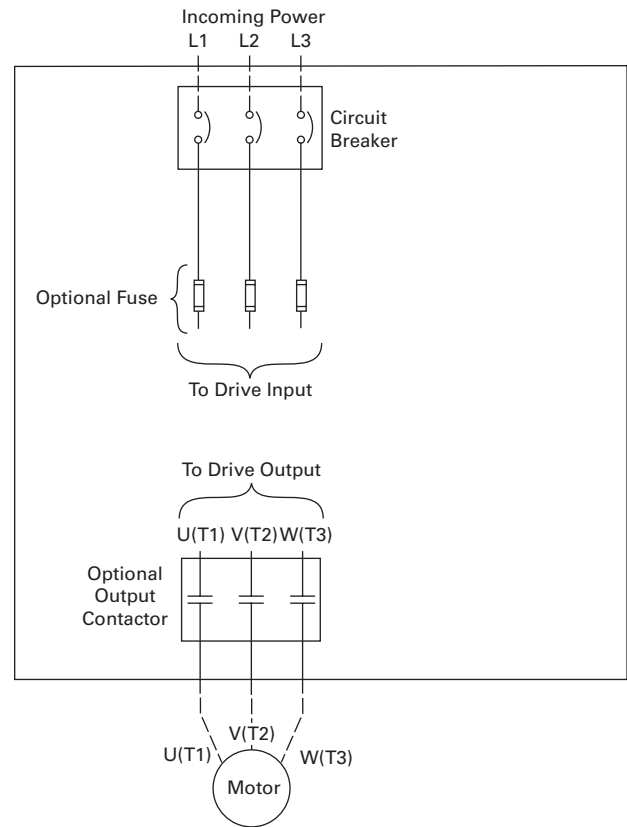

2.6

Adjustable Frequency Drives

H-Max Series Drives

Dimensions

Approximate Dimensions in Inches (mm)

2 H-Max Series IntelliPass and IntelliDisconnect Drives

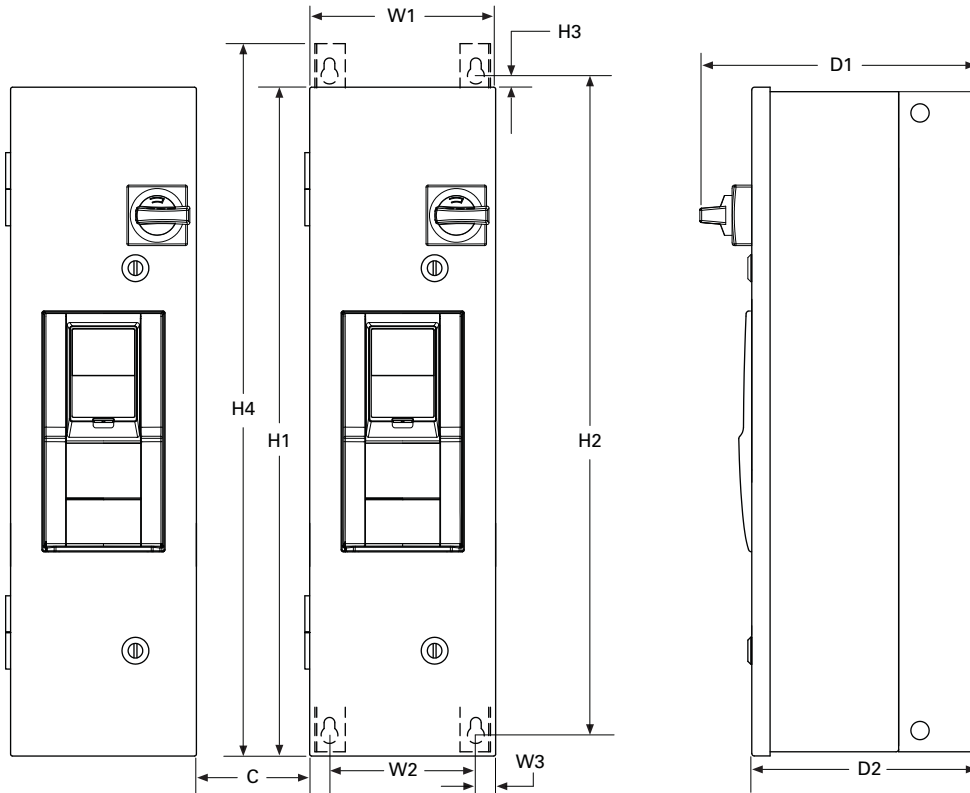

Consult factory or use manual for final dimensions.

Frame Size	Voltage	Horsepower (I _L)	H1	H2	H3	H4	C	W1	W2	W3	D1	D2	Weight in Lbs (kg)
FS4	208	1–3	30.00	29.41	0.25	31.00	3.00	7.88	6.25	0.75	12.49	10.36	45 (20.41)
	230	1–3	(762.0)	(747.1)	(6.35)	(787.4)	(76.2)	(200.2)	(158.8)	(19.1)	(317.2)	(263.1)	
	480	1–7.5											
FS5	208	5–10	37.00	36.72	0.25	38.31	3.00	9.60	7.97	0.75	15.35	13.22	57.5 (26.10)
	230	5–10	(939.8)	(932.7)	(6.35)	(973.0)	(76.2)	(243.8)	(202.4)	(19.1)	(390.0)	(335.8)	
	480	10–20											
FS6	208	15–20	45.45	44.81	0.25	46.4	4.00	11.44	9.75	0.75	15.80	13.67	98.0 (44.45)
	230	15–20	(1154.4)	(1138.2)	(6.35)	(1178.6)	(101.6)	(290.6)	(247.6)	(19.1)	(401.3)	(347.2)	
	480	25–40											
FS7	208	25–30	58.51	57.87	0.25	59.46	5.00	14.52	12.83	0.75	15.68	13.72	165.0 (74.84)
	230	25–30	(1486.2)	(1470.0)	(6.35)	(1510.3)	(127.0)	(368.8)	(325.9)	(19.1)	(398.3)	(348.5)	
	480	50–75											

Note: C distance is spacing required to mount multiple drives.

Approximate Dimensions in Inches (mm)

Enclosure Box A NEMA Type 3R

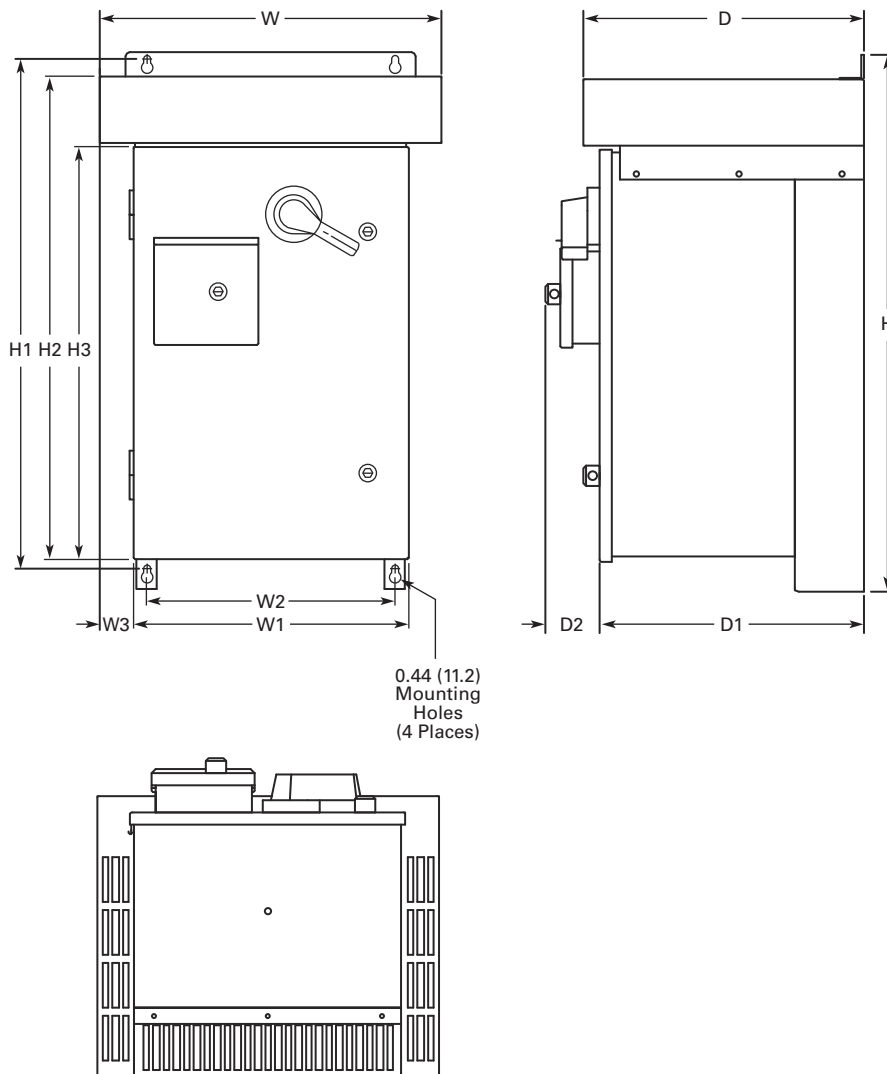

Voltage AC	hp (I _L)	H	H1	H2	H3	W	W1	W2	W3	D	D1	D2	Approx. Weight Lbs (kg)	Approx. Shipping Weight Lbs (kg)
Three-Phase														
208V	1-10	33.00	31.36	29.67	25.35	21.05	16.92	15.30	2.07	17.24	16.26	3.31	170 (77)	215 (98)
230V	1-10	(838.2)	(796.5)	(753.6)	(643.9)	(534.7)	(429.8)	(388.6)	(52.6)	(437.9)	(413.0)	(84.1)		
480V	1-20													

2.6

Adjustable Frequency Drives

H-Max Series Drives

Approximate Dimensions in Inches (mm)

Enclosure Box B NEMA Type 3R

2

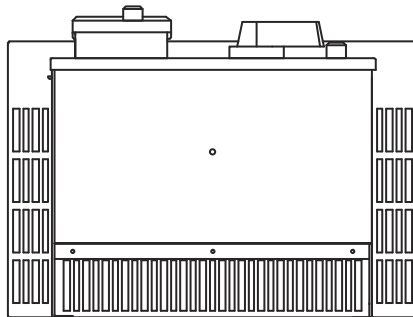
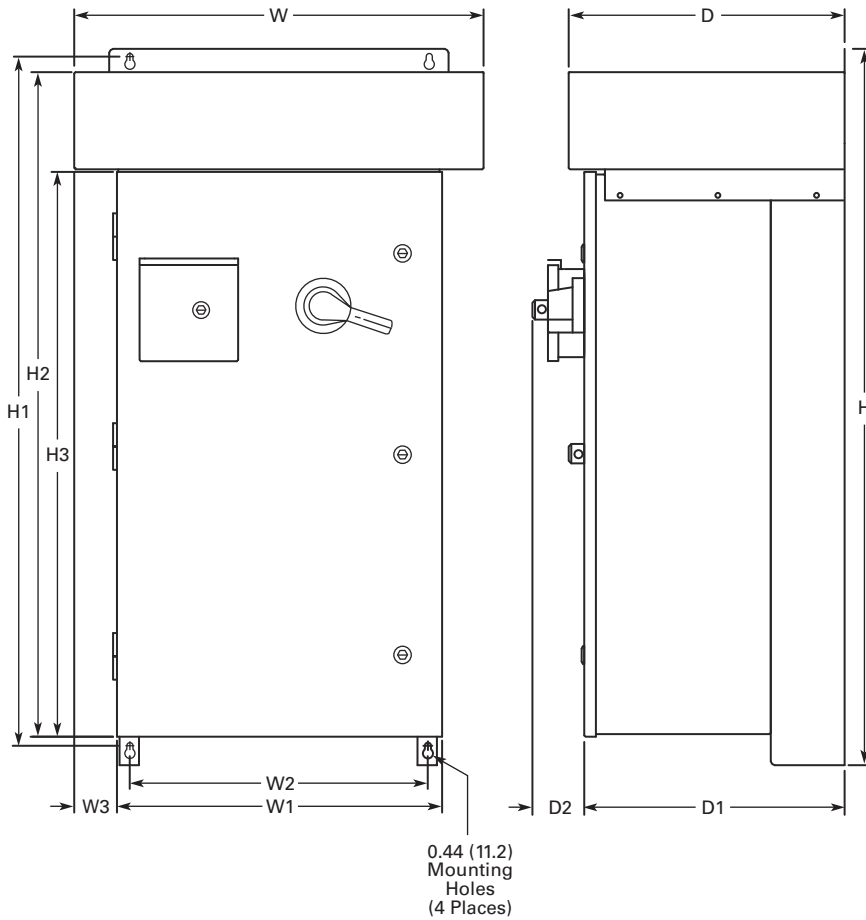

Voltage AC	hp (I _L)	H	H1	H2	H3	W	W1	W2	W3	D	D1	D2	Approx. Weight Lbs (kg)	Approx. Shipping Weight Lbs (kg)
Three-Phase														
208V	15	46.09 (1170.7)	44.45 (1129.0)	42.77 (1086.4)	36.35 (923.3)	26.31 (668.3)	20.92 (531.4)	19.30 (490.2)	2.69 (68.3)	17.74 (450.6)	16.76 (425.7)	3.31 (84.1)	235 (107)	290 (132)
230V	15													
480V	25-40													

Approximate Dimensions in Inches (mm)

Enclosure Box C NEMA Type 3R

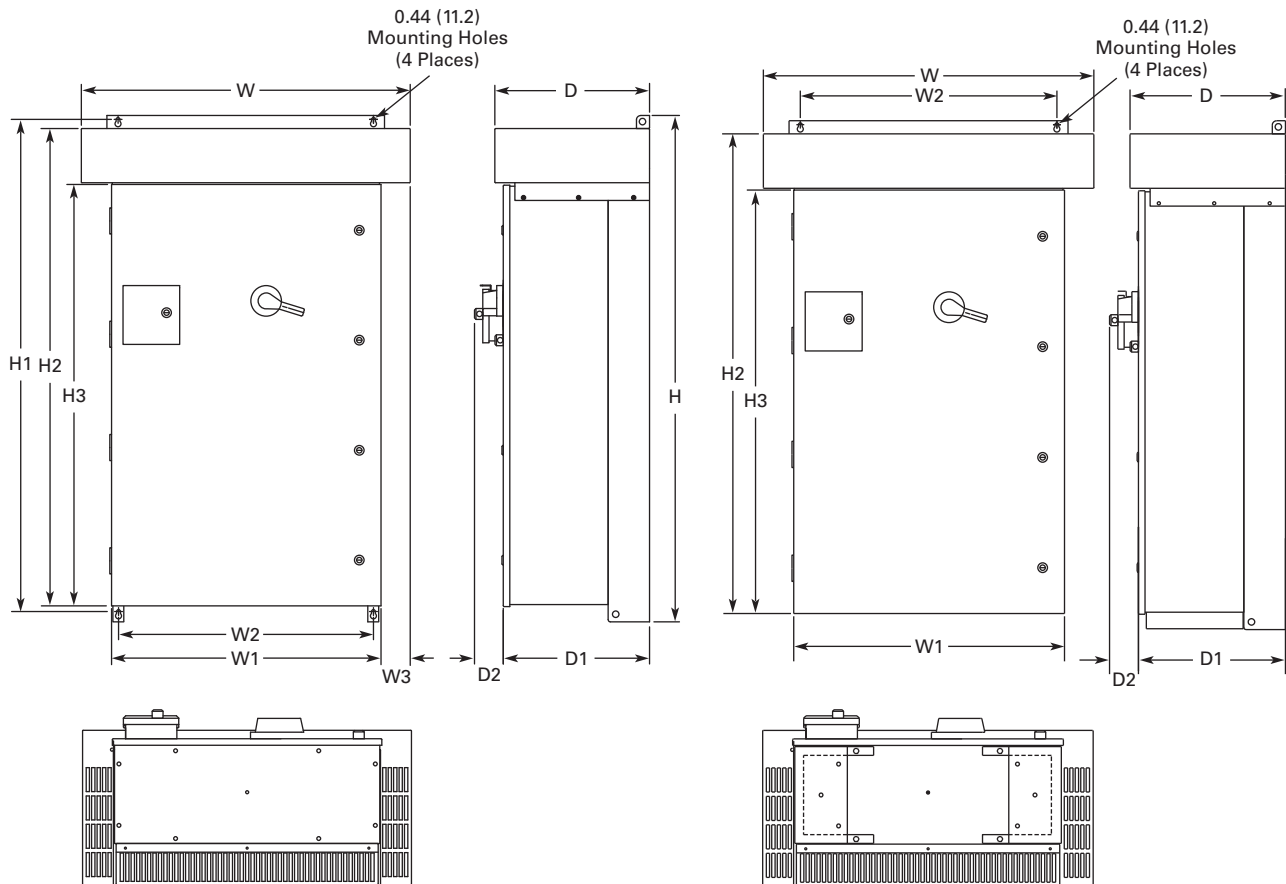

Voltage AC	hp (I _L)	H	H1	H2	H3	W	W1	W2	W3	D	D1	D2	Approx. Weight Lbs (kg)
Three-Phase													
208	20–30	58.09	56.45	54.77	48.35	37.73	30.92	29.30	3.34	17.74	16.77	3.31	①
230	20–30	(1475.5)	(1433.8)	(1391.2)	(1228.1)	(958.3)	(785.4)	(744.2)	(84.8)	(450.6)	(426.0)	(84.1)	
480	50–75												

Note

① Consult factory.

SPX9000 Drives

2



Contents

Description

Page

SPX9000 Drives	
Features and Benefits	V6-T2-159
Standards and Certifications	V6-T2-159
Catalog Number Selection	V6-T2-160
Product Selection	V6-T2-161
Accessories	V6-T2-166
Options	V6-T2-167
Replacement Parts	V6-T2-174
Technical Data and Specifications	V6-T2-183
Dimensions	V6-T2-184

Product Description

The SPX9000 Series Adjustable Frequency Drives from Eaton's Electrical Sector are specifically designed for high performance applications. Equipped with high processing power, the SPX9000 can use information from an encoder or a resolver in order to provide very precise motor control. Sensorless vector and simple frequency control are also supported. Typical applications requiring high performance are: master-slave drives, positioning applications, winder tension control and synchronization.

The core of the SPX9000 is a fast microprocessor, providing high dynamic performance for applications where good motor handling and reliability are required. It can be used both in open loop applications as well as in applications requiring encoder feedback.

The SPX9000 supports fast drive-to-drive communication. It also offers an integrated data logger functionality for analysis of dynamic events without the need of additional hardware. Simultaneous fast monitoring of several drives can be done by using the 9000Xdrive tool and CAN communication. In applications where reliability and quality are essential for high-performance, the SPX9000 is the logical choice.

The Eaton family of drives includes DA1, DC1, H-Max, M-Max, SVX9000 and SPX9000. 9000X Series drive ratings are rated for either high overload (I_H) or low overload (I_L). I_L indicates 110% overload capacity for 1 minute out of 10 minutes. I_H indicates 150% overload capacity for 1 minute out of 10 minutes.

Features and Benefits

- Speed error <0.01 %, depending on the encoder
- Incremental or absolute encoder support
- Encoder voltages of 5V (RS-422), 15V or 24V, depending on the option card
- Full torque control at all speeds, including zero
- Torque accuracy <2%; <5% down to zero speed
- Starting torque >200%, depending on motor and drive sizing
- Integrated datalogger for system analysis
- Fast multiple drive monitoring with PC
- Full capability for master/slave configurations
- High-speed bus (12 Mbit/s) for fast inter-drive communication
- High-speed applications (up to 7200 Hz) possible
- Robust design—proven 500,000 hours MTBF
- Integrated 3% line reactors standard on drives from FR4 through FR9
- Line reactor is included but is separated from chassis
- EMI/RFI Filters H standard up to 200 hp I_H 480V, 100 hp I_H 230V
- Simplified operating menu allows for typical programming changes, while programming mode provides control of everything
- Quick Start Wizard built into the programming of the drive ensures a smooth start-up
- Keypad can display up to three monitored parameters simultaneously
- LOCAL/REMOTE operation from keypad
- Copy/paste function allows transfer of parameter settings from one drive to the next
- Standard NEMA Type 12/IP54 keypad on all drives
- Hand-held auxiliary 240 power supply allows programming/monitoring of control module without applying full power to the drive
- The SPX can be flexibly adapted to a variety of needs using our pre-installed “Seven in One” precision application programs consisting of:
 - Basic
 - Standard
 - Local/remote
 - Multi-step speed control
 - PID control
 - Multi-purpose control
 - Pump and fan control with auto change
- Additional I/O and communication cards provide plug and play functionality
- I/O connections with simple quick connection terminals
- Control logic can be powered from an external auxiliary control panel, internal drive functions and fieldbus if necessary
- Brake chopper standard from: 1–30 hp/380–500V 3/4–15 hp/208–230V
- NEMA Type 1/IP21 enclosures available Frame Sizes FR4–FR11, NEMA Type 12/IP54 enclosures available Frame Sizes FR4–FR10 (FR10 and FR11 freestanding drives)
- Open chassis FR10 and greater
- Standard option board configuration includes an A9 I/O board and an A2 relay output board installed in slots A and B

Standards and Certifications

Product

- IEC 61800-2

Safety

- UL 508C

EMC (at default settings)

- Immunity: Fulfills all EMC immunity requirements; Emissions: EN 61800-3, LEVEL H

- UL Listed
- CE



Catalog Number Selection

SPX9000 Adjustable Frequency Drives

2

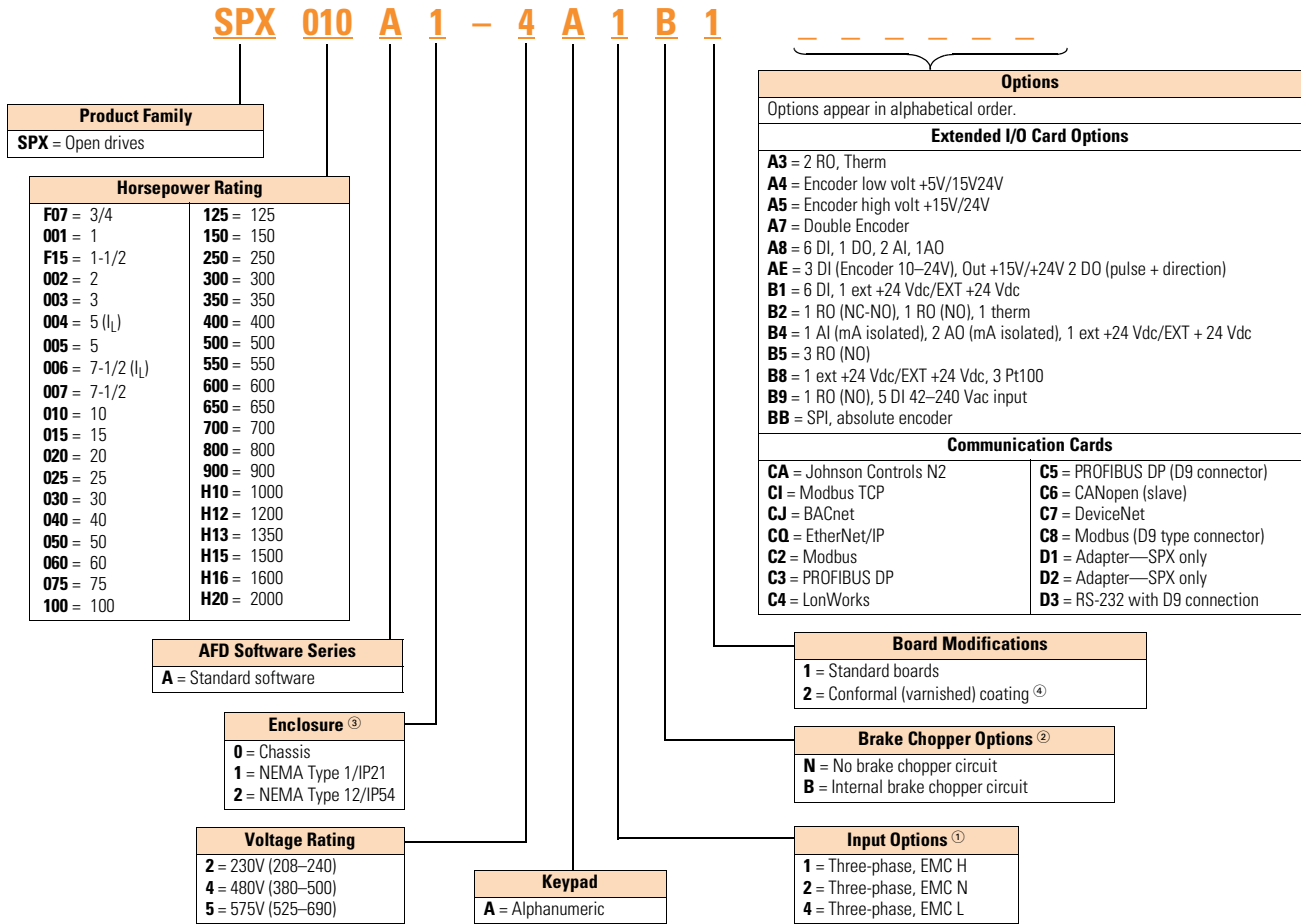

Notes

- ① All 230V drives and 480V drives up to 200 hp (I_H) are only available with input option 1 (EMC level H). 480V drives 250 hp (I_H) or larger are available with input option 2 (EMC level N). 575V drives 200 hp (I_H) or larger are available with input option 2. 575V drives up to 150 hp (I_H) are available with input option 4 (EMC level L). 480V and 690V freestanding drives are available with input option 4 (EMC level L).
- ② 480V drives up to 30 hp (I_H) are only available with brake chopper option B. 480V drives 40 hp (I_H) or larger come standard with brake chopper option N. 230V drives up to 15 hp (I_H) are only available with brake chopper option B. 230V drives 20 hp and larger come standard with brake chopper option N. All 575V drives come standard without brake chopper option (N). N = No brake chopper.
- ③ 480V drives 250–350 hp (I_H) and 690V drives 200–300 hp (I_H) are available with enclosure style 0 (chassis). 480V and 690V FR10 freestanding drives are available with 1 (NEMA Type 1/IP21) or 2 (NEMA Type 12/IP54). FR11 freestanding drives are only available with enclosure style 1 (NEMA Type 1/IP21).
- ④ Factory promise delivery. Consult sales office for availability.

Product Selection

230V Drives

SPX9000 Open Drives



208–240V, NEMA Type 1/IP21 Drives

Frame Size	hp (I _H)	Current (I _H)	hp (I _L)	Current (I _L)	Catalog Number
FR4	3/4	3.7	1	4.8	SPXF07A1-2A1B1
	1	4.8	1-1/2	6.6	SPX001A1-2A1B1
	1-1/2	6.6	2	7.8	SPXF15A1-2A1B1
	2	7.8	3	11	SPX002A1-2A1B1
	3	11	—	12.5	SPX003A1-2A1B1
FR5	—	12.5	5	17.5	SPX004A1-2A1B1
	5	17.5	7-1/2	25	SPX005A1-2A1B1
	7-1/2	25	10	31	SPX007A1-2A1B1
FR6	10	31	15	48	SPX010A1-2A1B1
	15	48	20	61	SPX015A1-2A1B1
FR7	20	61	25	75	SPX020A1-2A1N1
	25	75	30	88	SPX025A1-2A1N1
	30	88	40	114	SPX030A1-2A1N1
FR8	40	114	50	140	SPX040A1-2A1N1
	50	140	60	170	SPX050A1-2A1N1
	60	170	75	205	SPX060A1-2A1N1
FR9	75	205	100	261	SPX075A1-2A1N1
	100	261	—	—	SPX100A1-2A1N1

208–240V, NEMA Type 12/IP54 Drives

Frame Size	hp (I _H)	Current (I _H)	hp (I _L)	Current (I _L)	Catalog Number
FR4	3/4	3.7	1	4.8	SPXF07A2-2A1B1
	1	4.8	1-1/2	6.6	SPX001A2-2A1B1
	1-1/2	6.6	2	7.8	SPXF15A2-2A1B1
	2	7.8	3	11	SPX002A2-2A1B1
	3	11	—	12.5	SPX003A2-2A1B1
FR5	—	12.5	5	17.5	SPX004A2-2A1B1
	5	17.5	7-1/2	25	SPX005A2-2A1B1
	7-1/2	25	10	31	SPX007A2-2A1B1
FR6	10	31	15	48	SPX010A2-2A1B1
	15	48	20	61	SPX015A2-2A1B1
FR7	20	61	25	75	SPX020A2-2A1N1
	25	75	30	88	SPX025A2-2A1N1
	30	88	40	114	SPX030A2-2A1N1
FR8	40	114	50	140	SPX040A2-2A1N1
	50	140	60	170	SPX050A2-2A1N1
	60	170	75	205	SPX060A2-2A1N1
FR9	75	205	100	261	SPX075A2-2A1N1
	100	261	—	—	SPX100A2-2A1N1

480V Drives

2

SPX9000 Open Drives



380–500V, NEMA Type 1/IP21 Drives

Frame Size	hp (I _H)	Current (I _H)	hp (I _L)	Current (I _L)	Catalog Number
FR4	1	2.2	1-1/2	3.3	SPX001A1-4A1B1
	1-1/2	3.3	2	4.3	SPXF15A1-4A1B1
	2	4.3	3	5.6	SPX002A1-4A1B1
	3	5.6	5	7.6	SPX003A1-4A1B1
	5	7.6	—	9	SPX005A1-4A1B1
	—	9	7-1/2	12	SPX006A1-4A1B1
FR5	7-1/2	12	10	16	SPX007A1-4A1B1
	10	16	15	23	SPX010A1-4A1B1
	15	23	20	31	SPX015A1-4A1B1
FR6	20	31	25	38	SPX020A1-4A1B1
	25	38	30	46	SPX025A1-4A1B1
	30	46	40	61	SPX030A1-4A1B1
FR7	40	61	50	72	SPX040A1-4A1N1
	50	72	60	87	SPX050A1-4A1N1
	60	87	75	105	SPX060A1-4A1N1
FR8	75	105	100	140	SPX075A1-4A1N1
	100	140	125	170	SPX100A1-4A1N1
	125	170	150	205	SPX125A1-4A1N1
FR9	150	205	200	261	SPX150A1-4A1N1
	200	245	250	300	SPX200A1-4A1N1

380–500V, NEMA Type 1/IP21 Freestanding Drives

Frame Size	hp (I _H)	Current (I _H)	hp (I _L)	Current (I _L)	Catalog Number
FR10	250	330	300	385	SPX250A1-4A4N1
	300	385	350	460	SPX300A1-4A4N1
	350	460	400	520	SPX350A1-4A4N1
FR11	400	520	500	590	SPX400A1-4A4N1
	500	590	550	650	SPX500A1-4A4N1
	550	650	600	730	SPX550A1-4A4N1

Note

Integrated fuses as standard. Limited option selection available; 115V transformer (KB), light kit (L1), HOA (K4), speed potentiometer w/HOA (K2), Disconnect switch (P2). See Freestanding Option selection on **Page V6-T2-173**.

SPX9000 Open Drives



380–500V, NEMA Type 12/IP54 Drives

Frame Size	hp (I _H)	Current (I _H)	hp (I _L)	Current (I _L)	Catalog Number
FR4	1	2.2	1-1/2	3.3	SPX001A2-4A1B1
	1-1/2	3.3	2	4.3	SPXF15A2-4A1B1
	2	4.3	3	5.6	SPX002A2-4A1B1
	3	5.6	5	7.6	SPX003A2-4A1B1
	5	7.6	—	9	SPX005A2-4A1B1
	—	9	7-1/2	12	SPX006A2-4A1B1
FR5	7-1/2	12	10	16	SPX007A2-4A1B1
	10	16	15	23	SPX010A2-4A1B1
	15	23	20	31	SPX015A2-4A1B1
FR6	20	31	25	38	SPX020A2-4A1B1
	25	38	30	46	SPX025A2-4A1B1
	30	46	40	61	SPX030A2-4A1B1
FR7	40	61	50	72	SPX040A2-4A1N1
	50	72	60	87	SPX050A2-4A1N1
	60	87	75	105	SPX060A2-4A1N1
FR8	75	105	100	140	SPX075A2-4A2N1
	100	140	125	170	SPX100A2-4A1N1
	125	170	150	205	SPX125A2-4A1N1
FR9	150	205	200	261	SPX150A2-4A1N1
	200	245	250	300	SPX200A2-4A1N1

380–500V, NEMA Type 12/IP54 Freestanding Drives

Frame Size	hp (I _H)	Current (I _H)	hp (I _L)	Current (I _L)	Catalog Number
FR10	250	330	300	385	SPX250A2-4A4N1
	300	385	350	460	SPX300A2-4A4N1
	350	460	400	520	SPX350A2-4A4N1

380–500V, Open Chassis Drives

Frame Size	hp (I _H)	Current (I _H)	hp (I _L)	Current (I _L)	Catalog Number
FR10	250	330	300	385	SPX250A0-4A2N1
	300	385	—	460	SPX300A0-4A2N1
	350	460	400	520	SPX350A0-4A2N1
FR11	400	520	500	590	SPX400A0-4A2N1
	500	590	—	650	SPX500A0-4A2N1
	—	650	600	730	SPX550A0-4A2N1
FR12	600	730	—	820	SPX600A0-4A2N1
	—	820	700	920	SPX650A0-4A2N1
	700	920	800	1030	SPX700A0-4A2N1
FR13	800	1030	900	1150	SPX800A0-4A2N1
	900	1150	1000	1300	SPX900A0-4A2N1
	1000	1300	1200	1450	SPXH10A0-4A2N1
FR14	1200	1600	1500	1770	SPXH12A0-4A2N1
	1600	1940	1800	2150	SPXH16A0-4A2N1

Notes

Integrated fuses as standard. Limited option selection available; 115V transformer (KB), light kit (L1), HOA (K4), speed potentiometer w/HOA (K2), disconnect switch (P2). See Freestanding Option selection on [Page V6-T2-173](#).

① FR10–FR14 includes 3% line reactor, but it is not integral to chassis.

575V Drives

2

SPX9000 Open Drives



525–690V, NEMA Type 1/IP21 Drives

Frame Size	hp (I _H)	Current (I _H)	hp (I _L)	Current (I _L)	Catalog Number
FR6	2	3.3	3	4.5	SPX002A1-5A4N1
	3	4.5	—	5.5	SPX003A1-5A4N1
	—	5.5	5	7.5	SPX004A1-5A4N1
	5	7.5	7-1/2	10	SPX005A1-5A4N1
	7-1/2	10	10	13.5	SPX007A1-5A4N1
	10	13.5	15	18	SPX010A1-5A4N1
	15	18	20	22	SPX015A1-5A4N1
	20	22	25	27	SPX020A1-5A4N1
FR7	25	27	30	34	SPX025A1-5A4N1
	30	34	40	41	SPX030A1-5A4N1
FR8	40	41	50	52	SPX040A1-5A4N1
	50	52	60	62	SPX050A1-5A4N1
	60	62	75	80	SPX060A1-5A4N1
FR9	75	80	100	100	SPX075A1-5A4N1
	100	100	125	125	SPX100A1-5A4N1
	125	125	150	144	SPX125A1-5A4N1
	150	144	—	170	SPX150A1-5A4N1
	—	170	200	208	SPX175A1-5A4N1

525–690V, NEMA Type 1/IP21 Freestanding Drives

Frame Size	hp (I _H)	Current (I _H)	hp (I _L)	Current (I _L)	Catalog Number
FR10	200	208	250	261	SPX200A1-5A4N1
	250	261	300	325	SPX250A1-5A4N1
	300	325	400	385	SPX300A1-5A4N1
FR11	400	385	450	460	SPX400A1-5A4N1
	450	460	500	502	SPX450A1-5A4N1
	500	502	550	590	SPX500A1-5A4N1

Note

Integrated fuses as standard. Limited option selection available; 115V transformer (KB), light kit (L1), HOA (K4), speed potentiometer w/HOA (K2), disconnect switch (P2). See Freestanding Option selection on **Page V6-T2-173**.

SPX9000 Open Drives



525–690V, NEMA Type 12/IP54 Drives

Frame Size	hp (I _H)	Current (I _H)	hp (I _L)	Current (I _L)	Catalog Number
FR6	2	3.3	3	4.5	SPX002A2-5A4N1
	3	4.5	—	5.5	SPX003A2-5A4N1
	—	5.5	5	7.5	SPX004A2-5A4N1
	5	7.5	7-1/2	10	SPX005A2-5A4N1
	7-1/2	10	10	13.5	SPX007A2-5A4N1
	10	13.5	15	18	SPX010A2-5A4N1
	15	18	20	22	SPX015A2-5A4N1
	20	22	25	27	SPX020A2-5A4N1
	25	27	30	34	SPX025A2-5A4N1
FR7	30	34	40	41	SPX030A2-5A4N1
	40	41	50	52	SPX040A2-5A4N1
FR8	50	52	60	62	SPX050A2-5A4N1
	60	62	75	80	SPX060A2-5A4N1
	75	80	100	100	SPX075A2-5A4N1
FR9	100	100	125	125	SPX100A2-5A4N1
	125	125	150	144	SPX125A2-5A4N1
	150	144	—	170	SPX150A2-5A4N1
	—	170	200	208	SPX175A2-5A4N1

525–690V, NEMA Type 12/IP54 Freestanding Drives

Frame Size	hp (I _H)	Current (I _H)	hp (I _L)	Current (I _L)	Catalog Number
FR10	200	208	250	261	SPX200A2-5A4N1
	250	261	300	325	SPX250A2-5A4N1
	300	325	400	385	SPX300A2-5A4N1

525–690V, Open Chassis Drives

Frame Size	hp (I _H)	Current (I _H)	hp (I _L)	Current (I _L)	Catalog Number
FR10	200	208	250	261	SPX200A0-5A2N1
	250	261	300	325	SPX250A0-5A2N1
	300	325	400	385	SPX300A0-5A2N1
FR11	400	385	450	460	SPX400A0-5A2N1
	450	460	500	502	SPX450A0-5A2N1
	500	502	—	590	SPX500A0-5A2N1
FR12	—	590	600	650	SPX550A0-5A2N1
	600	650	700	750	SPX600A0-5A2N1
	700	750	800	820	SPX700A0-5A2N1
FR13	800	820	900	920	SPX800A0-5A2N1
	900	920	1000	1030	SPX900A0-5A2N1
	1000	1030	1250	1180	SPXH10A0-5A2N1
FR14	1350	1300	1500	1500	SPXH13A0-5A2N1
	1500	1500	2000	1900	SPXH15A0-5A2N1
	2000	1900	2300	2250	SPXH20A0-5A2N1

Notes

Integrated fuses as standard. Limited option selection available; 115V transformer (KB), light kit (L1), HOA (K4), speed potentiometer w/HOA (K2), disconnect switch (P2). See Freestanding Option selection on [Page V6-T2-173](#).

⊙ FR10–FR14 includes 3% line reactor, but it is not integral to chassis.

Accessories

2

Demo Drive and Power Supply

Demo Drive and Power Supply

Description	Catalog Number
9000X demo drive	9000XDEMO

NEMA Type 12/IP54 Conversion Kit

The NEMA Type 12/IP54 kit option is used to convert a NEMA Type 1/IP21 to a NEMA Type 12/IP54 drive. The NEMA Type 12/IP54 kit consists of a metal drive shroud, fan kit for some frames, adaptor plate and plugs.

NEMA Type 12/IP54 Conversion Kit

Frame Size	Delivery Code	Approximate Dimensions in Inches (mm)			Approximate Weight Lb (kg)	Catalog Number
		Length	Width	Height		
FR4	W	13 (330)	7 (178)	4 (102)	4 (1.8)	OPTN12FR4
FR5		16 (406)	8 (203)	7 (178)	5 (2.3)	OPTN12FR5
FR6		21 (533)	10 (254)	5 (127)	7 (3.2)	OPTN12FR6

Flange Kits

Flange Kit NEMA Type 12/IP54

The flange kit is utilized when the power section is mounted through the back panel of an enclosure. Includes flange mount brackets and NEMA Type 12/IP54 fan components. Metal shroud not included.

Flange kits for NEMA Type 12/IP54 enclosure drive rating are determined by rating of drive.

Flange Kit NEMA Type 12/IP54— Frames 4, 5 and 6 ^①

Frame Size	Delivery Code	Catalog Number
FR4	W	OPTTHRFR4
FR5		OPTTHRFR5
FR6		OPTTHRFR6

Flange Kit NEMA Type 12/IP54— Frames 4–9

Frame Size	Delivery Code	Catalog Number
FR4	FP	OPTTHR4
FR5		OPTTHR5
FR6		OPTTHR6
FR7		OPTTHR7
FR8		OPTTHR8
FR9		OPTTHR9

Note

^① For installation of an SPX9000 NEMA Type 1/IP21 drive into a NEMA Type 12/IP54 oversized enclosure.

Options

9000X Series Option Board Kits

The 9000X Series drives can accommodate a wide selection of expander and adapter option boards to customize the drive for your application needs. The drive's control unit is designed to accept a total of five option boards.

The 9000X Series factory installed standard board configuration includes an A9 I/O board and an A2 relay output board, which are installed in slots A and B.

Option Boards

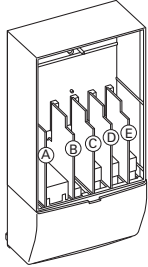

Option Board Kits

Option Kit Description ^①	Allowed Slot Locations ^②	Field Installed Catalog Number	Factory Installed Option Designator	SVX Ready Programs						
				Basic	Local/Remote	Standard	MSS	PID	Multi-P.	PFC
Standard I/O Cards										
6 DI, 1 DO, 2 AI, 1AO, 1 +10 Vdc ref, 2 ext +24 Vdc/EXT +24 Vdc	A	OPTA9	—	■	■	■	■	■	■	■
2 RO (NC-NO)	B	OPTA2	—	■	■	■	■	■	■	■
Extended I/O Cards										
2 RO, therm	B	OPTA3	A3	—	■	■	■	■	■	■
Encoder low volt +5V/15V/24V	C	OPTA4	A4	—	■	■	■	■	■	■
Encoder high volt +15V/24V	C	OPTA5	A5	—	■	■	■	■	■	■
Double encoder—SPX only	C	OPTA7	A7	■	■	■	■	■	■	■
6 DI, 1 DO, 2 AI, 1 AO	A	OPTA8	A8	—	■	■	■	■	■	■
6 DI, 1 DO, 2 AI, 1AO, 1 +10 Vdc ref, 2 ext +24 Vdc/EXT +24 Vdc	A	OPTA1	—	■	■	■	■	■	■	■
3 DI (encoder 10–24V), out +15V/+24V, 2 DO (pulse+direction)—SPX only	C	OPTAE	AE	■	■	■	■	■	■	■
6 DI, 1 DO, 2 AI, 1AO, 1 +10 Vdc ref, 2 ext +24 Vdc/EXT +24 Vdc	A	OPTAFA1	—	■	■	■	■	■	■	■
6 DI, 1 ext +24 Vdc/EXT +24 Vdc	B, C, D , E	OPTB1	B1	—	—	—	—	—	■	■
1 RO (NC-NO), 1 RO (NO), 1 therm	B, C, D , E	OPTB2	B2	—	—	—	—	—	■	■
1 AI (mA isolated), 2 AO (mA isolated), 1 ext +24 Vdc/EXT +24 Vdc	B, C, D , E	OPTB4	B4	—	■	■	■	■	■	■
3 RO (NO)	B, C, D , E	OPTB5	B5	—	—	—	—	—	■	■
1 ext +24 Vdc/EXT +24 Vdc, 3 Pt100	B, C, D , E	OPTB8	B8	—	—	—	—	—	—	—
1 RO (NO), 5 DI 42–240 Vac input	B, C, D , E	OPTB9	B9	—	—	—	—	—	■	■
SPI, absolute encoder	C	OPTBB	BB	—	—	—	—	—	—	—
Communication Cards										
Modbus ^③	D, E	OPTC2	C2	■	■	■	■	■	■	■
Johnson Controls N2 ^③	D, E	OPTC2	CA	—	—	—	—	—	—	—
Modbus TCP	D, E	OPTC1	C1	■	■	■	■	■	■	■
BACnet	D, E	OPTCJ	C4	■	■	■	■	■	■	■
EtherNet/IP	D, E	OPTCQ	CQ	■	■	■	■	■	■	■
PROFIBUS DP	D, E	OPTC3	C3	■	■	■	■	■	■	■
LonWorks	D, E	OPTC4	C4	■	■	■	■	■	■	■
PROFIBUS DP (D9 connector)	D, E	OPTC5	C5	■	■	■	■	■	■	■
CANopen (slave)	D, E	OPTC6	C6	■	■	■	■	■	■	■
DeviceNet	D, E	OPTC7	C7	■	■	■	■	■	■	■
Modbus (D9 type connector)	D, E	OPTC8	C8	■	■	■	■	■	■	■
Adapter—SPX only	D, E	OPTD1	D1	■	■	■	■	■	■	■
Adapter—SPX only	D, E	OPTD2	D2	■	■	■	■	■	■	■
RS-232 with D9 connection	D, E	OPTD3	D3	■	■	■	■	■	■	■

Notes

① AI = Analog Input; AO = Analog Output, DI = Digital Input, DO = Digital Output, RO = Relay Output

② Option card must be installed in one of the slots listed for that card. Slot indicated in bold is the preferred location.

③ OPTC2 is a multi-protocol option card.

Modbus RTU Network Communications

The Modbus Network Card OPTC2 is used for connecting the 9000X Drive as a slave on a Modbus network. The interface is connected by a 9-pin DSUB connector (female) and the baud rate ranges from 300 to 19200 baud. Other communication parameters include an address range from 1 to 247; a parity of None, Odd or Even; and the stop bit is 1.

PROFIBUS Network Communications

The PROFIBUS Network Card OPTC3 is used for connecting the 9000X Drive as a slave on a PROFIBUS-DP network. The interface is connected by a 9-pin DSUB connector (female). The baud rates range from 9.6K baud to 12M baud, and the addresses range from 1 to 127.

LonWorks Network Communications

The LonWorks Network Card OPTC4 is used for connecting the 9000X Drive on a LonWorks network. This interface uses Standard Network Variable Types (SNVT) as data types. The channel connection is achieved using a FTT-10A Free Topology transceiver via a single twisted transfer cable. The communication speed with LonWorks is 78 kBits/s.

CANopen (Slave) Communications

The CANopen (Slave) Network Card OPTC6 is used for connecting the 9000X Drive to a host system. According to ISO11898 standard cables to be chosen for CAN bus should have a nominal impedance of 120 ohms, and specific line delay of nominal 5 nS/m. 120 ohms line termination resistors required for installation.

DeviceNet Network Communications

The DeviceNet Network Card OPTC7 is used for connecting the 9000X Drive on a DeviceNet Network. It includes a 5.08 mm pluggable connector. Transfer method is via CAN using a two-wire twisted shielded cable with two-wire bus power cable and drain. The baud rates used for communication include 125K baud, 250K baud and 500K baud.

Johnson Controls Metasys N2 Network Communications

The OPTC2 fieldbus board provides communication between the 9000X Drive and a Johnson Controls Metasys™ N2 network. With this connection, the drive can be controlled, monitored and programmed from the Metasys system. The N2 fieldbus is available as a factory installed option and as a field installable kit.

Modbus/TCP Network Communications

The Modbus/TCP Network Card OPTC1 is used for connecting the 9000X Drive to Ethernet networks utilizing Modbus protocol. It includes an RJ-45 pluggable connector. This interface provides a selection of standard and custom register values to communicate drive parameters. The board supports 10 Mbps and 100 Mbps communication speeds. The IP address of the board is configurable over Ethernet using a supplied software tool.

BACnet Network Communications

The BACnet Network Card OPTCJ is used for connecting the 9000X Drive to BACnet networks. It includes a 5.08 mm pluggable connector. Data transfer is Master-Slave/Token Passing (MS/TP) RS-485. This interface uses a collection of 30 Binary Value Objects (BVOs) and 35 Analog Value Objects (AVOs) to communicate drive parameters. The card supports 9.6, 19.2 and 38.4 Kbaud communication speeds and supports network addresses 1–127.

EtherNet/IP Network Communications

The EtherNet/IP Network Card OPTCK is used for connecting the 9000X Drive to Ethernet/Industrial Protocol networks. It includes an RJ-45 pluggable connector. The interface uses CIP objects to communicate drive parameters (CIP is "Common Industrial Protocol", the same protocol used by DeviceNet). The board supports 10 Mbps and 100 Mbps communication speeds. The IP address of the board is configurable by Static, BOOTP and DHCP methods.

Control Panel Options

Factory Options

Description	Factory Installed Option Code	Field Installed NEMA Type 1/IP21 Catalog Number
Local/Remote Keypad SVX9000 Control Panel —This option is standard on all drives and consists of an RS-232 connection, backlit alphanumeric LCD display with nine indicators for the RUN status and two indicators for the control source. The nine pushbuttons on the panel are used for panel programming and monitoring of all SVX9000 parameters. The panel is detachable and isolated from the input line potential. Include LOC/REM key to choose control location.	A	KEYPAD-LOC/REM
Keypad Remote Mounting Kit —This option is used to remote mount the SVX9000 keypad. The footprint is compatible to the SV9000 remote mount kit. Includes 10 ft cable, keypad holder and mounting hardware.	—	OPTRMT-KIT-9000X
Keypad Blank —9000X Series select keypad for use with special and custom applications.	—	KEYPAD-BLANK

Miscellaneous Options

Description	Catalog Number
9000XDrive —A PC-based tool for controlling and monitoring of the SVX9000. Features include: loading parameters that can be saved to a file or printed, setting references, starting and stopping the motor, monitoring signals in graphical or text form, and real-time display. To avoid damage to the drive or computer, SVDrivecable must be used.	9000XDRIVE
SVDrivecable —6 ft (1.8m) RS-232 cable (22 gauge) with a 7-pin connector on each end. Should be used in conjunction with the 9000XDrive option to avoid damage to the SVX9000 or computer. The same cable can be used for downloading specialized applications to the drive.	SVDRIVECABLE
External Dynamic Braking Resistors —Used with the dynamic braking chopper circuit to absorb motor regenerative energy for stopping the load and to dissipate the energy flowing back into the drive. Resistors are separated into standard duty and heavy-duty. Standard duty is defined as 20% duty or less with 100% braking torque, while heavy-duty is defined as 50% duty or less with 150% braking torque.	See Page V6-T2-170

2.7

Adjustable Frequency Drives

SPX9000 Drives

SPX9000 Drive Options

2

Brake Chopper Options

The brake chopper circuit option is used for applications that require dynamic braking. Dynamic braking resistors are not included with drive purchase. Consult the factory for additional dynamic braking resistor selections that are supplied separately. A list of common resistors are listed below and are complete indoor assemblies, include a pre-wired terminal block and a thermal switch, and are not UL Listed.

Duty Cycle

The duty cycle rating is based on a 60-second period. For example, the 20% duty cycle resistor can carry 100% current for 12 seconds out of every 60 seconds, while the 50% duty cycle resistor can carry 150% current for 30 seconds out of every 60 seconds.

Torque

If the braking torque required is less than 15%, dynamic braking is not required because the regenerated energy will be dissipated in the drive and motor losses.

Dynamic Brake Resistor—Catalog Number Selection

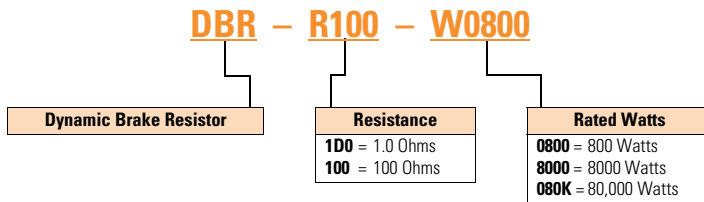

230V Brake Resistors

Drive hp (CT/1/4)	Minimum Ohms	20% Duty Cycle, 100% Torque		50% Duty Cycle, 150% Torque	
		Catalog Number	Dimensions (Inches)	Catalog Number	Dimensions (Inches)
0.75	30.0	DBR-R100-W0400	12W x 5D x 5H	DBR-R100-W0800	12W x 7D x 5H
1	30.0	DBR-R100-W0400	12W x 5D x 5H	DBR-R100-W0800	12W x 7D x 5H
1.5	30.0	DBR-R100-W0400	12W x 5D x 5H	DBR-R036-W1200	12W x 10D x 5H
2	30.0	DBR-R100-W0400	12W x 5D x 5H	DBR-R036-W1200	12W x 10D x 5H
3	30.0	DBR-R036-W0800	12W x 7D x 5H	DBR-R036-W2000	12W x 16D x 5H
4	30.0	DBR-R036-W0800	12W x 7D x 5H	DBR-R030-W2400	19W x 10D x 5H
5	30.0	DBR-R036-W0800	12W x 7D x 5H	DBR-R030-W2800	19W x 13D x 5H
7.5	20.0	DBR-R020-W1200	12W x 10D x 5H	DBR-R020-W4800	26.5W x 13D x 5H
10	10.0	DBR-R015-W1600	12W x 13D x 5H	DBR-R112-W6000	26.5W x 13D x 5H
15	10.0	DBR-R012-W2400	19W x 10D x 5H	DBR-R010-W9000	28W x 10D x 10H
20	3.3	DBR-R9D3-W3200	19W x 10D x 5H	DBR-R3D4-W012K	28W x 10D x 10H
25	3.3	DBR-R5D5-W4000	26.5W x 10D x 5H	DBR-R5D1-W015K	28W x 16D x 10H
30	3.3	DBR-R4D8-W4800	26.5W x 10D x 5H	DBR-R4D1-W020K	28W x 16D x 10H
40	1.4	DBR-R004-W6000	26.5W x 13D x 5H	DBR-R3D4-W025K	30W x 18D x 16H
50	1.4	DBR-R3D1-W7500	26.5W x 16D x 5H	DBR-R2D1-W030K	30W x 18D x 24H
60	1.4	DBR-R2D8-W9000	26.5W x 16D x 5H	DBR-R002-W036K	30W x 18D x 24H
75	1.4	DBR-R2D6-W012K	28W x 10D x 10H	DBR-R1D5-W045K	30W x 18D x 32H
100	1.4	DBR-R002-W015K	28W x 16D x 10H	DBR-R1D4-W060K	30W x 18D x 40H

480V Brake Resistors

Drive hp (CT/l _H)	Minimum Ohms	20% Duty Cycle, 100% Torque		50% Duty Cycle, 150% Torque	
		Catalog Number	Dimensions (Inches)	Catalog Number	Dimensions (Inches)
1	63.0	DBR-R100-W0400	12W x 5D x 5H	DBR-R100-W0800	12W x 7D x 5H
1.5	63.0	DBR-R100-W0400	12W x 5D x 5H	DBR-R100-W1200	12W x 10D x 5H
2	63.0	DBR-R100-W0400	12W x 5D x 5H	DBR-R100-W1200	12W x 10D x 5H
3	63.0	DBR-R100-W0800	12W x 7D x 5H	DBR-R100-W2000	12W x 16D x 5H
5	63.0	DBR-R100-W0800	12W x 7D x 5H	DBR-R100-W2800	19W x 13D x 5H
6	63.0	DBR-R100-W1200	12W x 10D x 5H	DBR-R070-W4000	19W x 16D x 5H
7.5	63.0	DBR-R100-W1200	12W x 10D x 5H	DBR-R063-W4800	26.5W x 13D x 5H
10	63.0	DBR-R063-W1600	12W x 13D x 5H	DBR-R063-W6000	26.5W x 16D x 5H
15	42.0	DBR-R042-W2400	19W x 10D x 5H	DBR-R042-W9000	28W x 10D x 10H
20	21.0	DBR-R030-W3200	19W x 13D x 5H	DBR-R023-W012K	28W x 13D x 10H
25	21.0	DBR-R030-W4000	19W x 16D x 5H	DBR-R021-W015K	28W x 13D x 10H
30	14.0	DBR-R020-W4800	26.5W x 13D x 5H	DBR-R014-W020K	30W x 18D x 24H
40	6.5	DBR-R112-W6000	26.5W x 13D x 5H	DBR-R007-W025K	30W x 18D x 16H
50	6.5	DBR-R013-W7500	26.5W x 16D x 5H	DBR-R8D5-W030K	30W x 18D x 24H
60	6.5	DBR-R010-W9000	28W x 10D x 10H	DBR-R7D3-W036K	30W x 18D x 24H
75	3.3	DBR-R009-W012K	28W x 13D x 10H	DBR-R3D3-W045K	30W x 18D x 32H
100	3.3	DBR-R5D1-W015K	28W x 16D x 10H	DBR-R004-W060K	30W x 18D x 40H
125	3.3	DBR-R4D1-W020K	28W x 16D x 10H	DBR-R004-W070K	30W x 18D x 48H
150	3.3	DBR-R3D4-W025K	30W x 18D x 16H	DBR-R3D5-W085K	30W x 18D x 56H
200	3.3	DBR-R3D3-W030K	30W x 18D x 24H	DBR-R3D3-W110K	30W x 18D x 72H
250	1.4	DBR-R2D5-W036K	30W x 18D x 24H	Ⓢ	—
300	1.4	DBR-R1D5-W045K	30W x 18D x 32H	Ⓢ	—
350	1.4	DBR-R1D4-W060K	30W x 18D x 40H	Ⓢ	—
400	0.9	DBR-R1D4-W060K	30W x 18D x 40H	Ⓢ	—
500	0.9	DBR-R0D9-W080K	30W x 18D x 48H	Ⓢ	—
550	0.9	DBR-R001-W085K	30W x 18D x 56H	Ⓢ	—

Note

Ⓢ Consult factory.

575V Brake Resistors

Drive hp (CT/l _H)	Minimum Ohms	20% Duty Cycle, 100% Torque		50% Duty Cycle, 150% Torque	
		Catalog Number	Dimensions (Inches)	Catalog Number	Dimensions (Inches)
2	100.0	DBR-R100-W0400	12W x 5D x 5H	DBR-R100-W1200	12W x 10D x 5H
3	100.0	DBR-R100-W0800	12W x 7D x 5H	DBR-R100-W2000	12W x 16D x 5H
4	100.0	DBR-R100-W0800	12W x 7D x 5H	DBR-R100-W2400	19W x 10D x 5H
5	100.0	DBR-R100-W0800	12W x 7D x 5H	DBR-R100-W2800	19W x 13D x 5H
7.5	100.0	DBR-R100-W1200	12W x 10D x 5H	DBR-R100-W4800	26.5W x 13D x 5H
10	30.0	DBR-R063-W1600	12W x 13D x 5H	DBR-R063-W6000	26.5W x 16D x 5H
15	30.0	DBR-R042-W2400	19W x 10D x 5H	DBR-R042-W9000	28W x 10D x 10H
20	30.0	DBR-R030-W3200	19W x 13D x 5H	DBR-R030-W012K	28W x 13D x 10H
25	30.0	DBR-R030-W4000	19W x 16D x 5H	DBR-R030-W015K	28W x 16D x 10H
30	18.0	DBR-R020-W4800	26.5W x 13D x 5H	DBR-R020-W020K	30W x 18D x 16H
40	18.0	DBR-R030-W6000	26.5W x 16D x 5H	DBR-R184-W025K	30W x 18D x 16H
50	9.0	DBR-R013-W7500	26.5W x 16D x 5H	DBR-R012-W030K	30W x 18D x 24H
60	9.0	DBR-R010-W9000	28W x 10D x 10H	DBR-R010-W036K	30W x 18D x 24H
75	9.0	DBR-R009-W012K	28W x 13D x 10H	DBR-R009-W045K	30W x 18D x 24H
100	7.0	DBR-R013-W015K	28W x 16D x 10H	DBR-R8D4-W060K	30W x 18D x 40H
125	7.0	DBR-R8D2-W020K	30W x 18D x 10H	DBR-R007-W070K	30W x 18D x 40H
150	7.0	DBR-R007-W025K	30W x 18D x 16H	DBR-R006-W085K	30W x 18D x 56H
175	7.0	DBR-R007-W030K	30W x 18D x 24H	DBR-R007-W100K	30W x 18D x 72H
200	2.5	DBR-R3D3-W030K	30W x 18D x 24H	DBR-R2D6-W110K	30W x 18D x 64H
250	2.5	DBR-R2D5-W036K	30W x 18D x 24H	DBR-R003-W140K	30W x 18D x 72H
300	2.5	DBR-R3D3-W045K	30W x 18D x 32H	⊕	—
400	1.7	DBR-R002-W060K	30W x 18D x 48H	⊕	—
450	1.7	DBR-R1D8-W070K	30W x 18D x 48H	⊕	—
500	1.7	DBR-R002-W080K	30W x 18D x 56H	⊕	—

Note

⊕ Consult factory.

Control/Communication Options**Available Control/Communications Options**

Option	Description	Option Type
K2	Door-Mounted Speed Potentiometer with HOA Selector Switch —Provides the SPX9000 with the ability to start/stop and adjust the speed reference from door-mounted control devices or remotely from customer supplied inputs. In HAND position, the drive will start and the speed is controlled by the door-mounted speed potentiometer. The drive will be disabled in the OFF position. When AUTO is selected, the drive run and speed control commands are via user-supplied dry contact and 4–20 mA signal.	Control
K4	HAND/OFF/AUTO Switch for Non-Bypass Configurations —Provides a three-position selector switch that allows the user to select either a HAND or AUTO mode of operation. HAND mode is defaulted to keypad operation, and AUTO mode is defaulted to control from an external terminal source. These modes of operation can be configured via programming to allow for alternate combinations of start and speed sources. Start and speed sources include keypad, I/O and fieldbus.	Control
KB	115V Control Transformer, 550 VA —Provides a fused control power transformer with additional 550 VA at 115V for customer use.	Control
L1	Power On and Fault Pilot Lights —Provide a white power on light that indicates power to the enclosed cabinet and a red fault light that indicates a drive fault has occurred.	Light
P2	Disconnect Switch —Disconnect switch option is applicable only with NEMA Type 1/IP21 and NEMA Type 12/IP54 Freestanding drives. Allows a convenient means of disconnecting the SPX9000 from the line, and the operating mechanism can be padlocked in the OFF position. This is factory-mounted in the enclosure.	Input

SPX Freestanding Options**480V and 690V Control Options, 200–550 hp** ^①

Description	Catalog Number Suffix
Door-mounted speed potentiometer with HOA selector switch	K2
HAND/OFF/AUTO switch (22 mm)	K4
115 volt control transformer 550 VA	KB

480V and 690V Light Options, 200–550 hp ^①

Description	Catalog Number Suffix
Power on/fault pilot lights	L1

Input Options, 200–550 hp ^①

Description	Catalog Number Suffix
Disconnect switch	P2 ^②

Notes

① Consult factory for adder information.

② Applicable with FR10 and FR11 freestanding designs only.

Replacement Parts

2

FR4 Spare Parts

Category	Description	Quantity/ Drive	230V Catalog Number	480V Catalog Number	575V Catalog Number
Control fan	NEMA Type 12 control fan ^①	1	PP01086	PP01086	—
Control module ^②	SPX control module	1	CPBS0000000000	CPBS0000000000	—
	Standard slot A I/O card	1	OPTA9	OPTA9	—
	Standard slot B I/O card	1	OPTA2	OPTA2	—
Converter	Power board ^③	1	VB00308-0004-2	VB00208-0003-5	—
		1	VB00308-0007-2	VB00208-0004-5	—
		1	VB00308-0008-2	VB00208-0005-5	—
		1	—	VB00208-0007-5	—
		1	—	VB00208-0009-5	—
		1	—	VB00410-0012-5-ARV	—
Keypad ^②	SVX/SPX keypad	1	KEYPAD-LOC/REM	KEYPAD-LOC/REM	—
Main fan ^②	DC fan (main)	1	PP01060	PP01060	—
Other	Mounting kit, fixing kit	1	FR00040	FR00040	—
	Mounting kit, fixing kit, N12 ^①	1	FR00079	FR00079	—
	Control cover, plastic, N1	1	FR00006	FR00006	—

FR5 Spare Parts

Category	Description	Quantity/ Drive	230V Catalog Number	480V Catalog Number	575V Catalog Number
Control fan	NEMA Type 12 control fan ^①	1	PP01088	PP01088	—
Control module ^②	SPX control module	1	CPBS0000000000	CPBS0000000000	—
	Standard slot A I/O card	1	OPTA9	OPTA9	—
	Standard slot B I/O card	1	OPTA2	OPTA2	—
Converter	Power board ^③	1	VB00313-0017-2	VB00213-0016-5	—
		1	VB00313-0025-2	VB00213-0022-5	—
		1	VB00313-0031-2	VB00213-0031-5	—
Keypad ^②	SVX/SPX keypad	1	KEYPAD-LOC/REM	KEYPAD-LOC/REM	—
Main fan ^②	DC fan (main)	1	PP01061	PP01061	—
Other	Mounting kit, fixing kit	1	FR00050	FR00050	—
	Mounting kit, fixing kit, N12 ^①	1	FR00081	FR00081	—
	Control cover, plastic, N1	1	FR05011	FR05011	—

Notes

- ① Only for NEMA Type 12/IP54 Type drives.
- ② Factory recommended spare parts.
- ③ Select one part number based on the amperage rating of the drive. Please contact EatonCare at 877-ETN-CARE for assistance.

FR6 Spare Parts

Category	Description	Quantity/ Drive	230V Catalog Number	480V Catalog Number	575V Catalog Number
Control fan	NEMA Type 12 control fan ^①	1	PP01049	PP01049	—
Control module ^②	SPX control module	1	CPBS0000000000	CPBS0000000000	CPBS0000000000
	Standard slot A I/O card	1	OPTA9	OPTA9	OPTA9
	Standard slot B I/O card	1	OPTA2	OPTA2	OPTA2
Converter	Power board ^③	1	VB00316-0048-2	VB00416-0038-5	VB00404-0004-6
		1	VB00316-0061-2	VB00416-0045-5	VB00404-0005-6
		1	—	VB00416-0061-5	VB00404-0007-6
		1	—	—	VB00404-0010-6
		1	—	—	VB00404-0013-6
		1	—	—	VB00404-0018-6
		1	—	—	VB00404-0022-6
		1	—	—	VB00404-0027-6
		1	—	—	VB00404-0034-6
DC section	Bus capacitor	2	—	—	S00930
Keypad ^②	SVX/SPX keypad	1	KEYPAD-LOC/REM	KEYPAD-LOC/REM	KEYPAD-LOC/REM
Main fan ^②	DC fan (main)	1	PP01062	PP01062	—
Other	Mounting kit, fixing kit	1	FR00060	FR00060	FR00060
	Mounting kit, fixing kit, N12 ^①	1	FR00082	FR00082	FR00082
	Control cover, plastic, N1	1	FR06011	FR06011	FR06011

FR7 Spare Parts

Category	Description	Quantity/ Drive	230V Catalog Number	480V Catalog Number	575V Catalog Number
Control fan	NEMA Type 12 control fan ^①	1	PP01049	PP01049	PP01049
Control module ^②	SPX control module	1	CPBS0000000000	CPBS0000000000	CPBS0000000000
	Standard slot A I/O card	1	OPTA9	OPTA9	OPTA9
	Standard slot B I/O card	1	OPTA2	OPTA2	OPTA2
Converter	Power board ^③	1	VB00319-0075-2	VB00619-0072-5	VB00419-0041-6
		1	VB00319-0088-2	VB00619-0087-5	VB00419-0052-6
		1	VB00319-0114-2	VB00619-0105-5	—
DC section	Bus capacitor	2	—	—	PP01041
Keypad ^②	SVX/SPX keypad	1	KEYPAD-LOC/REM	KEYPAD-LOC/REM	KEYPAD-LOC/REM
Main fan ^②	DC fan (main)	1	PP01063	PP01063	PP01063
Other	Mounting kit, fixing kit	1	FR07071	FR07071	FR07071
	Mounting kit, fixing kit, N12 ^①	1	FR07072	FR07072	FR07072
	Control cover, plastic, N1	1	FR07011	FR07011	FR07011

Notes

^① Only for NEMA Type 12/IP54 Type drives.

^② Factory recommended spare parts.

^③ Select one part number based on the amperage rating of the drive. Please contact EatonCare at 877-ETN-CARE for assistance.

FR8 Spare Parts

2

Category	Description	Quantity/ Drive	230V Catalog Number	480V Catalog Number	575V Catalog Number
Control fan	NEMA Type 12 control fan ^①	1	CP01180	CP01180	CP01180
Control module ^②	SPX control module	1	CPBS0000000000	CPBS0000000000	CPBS0000000000
	Standard slot A I/O card	1	OPTA9	OPTA9	OPTA9
	Standard slot B I/O card	1	OPTA2	OPTA2	OPTA2
Converter	Power board ^③	1	VB00722-0140-2-ANV	VB00636-0140-4-ANV	VB00422-0062-5-ANV
		1	VB00722-0170-2-ANV	VB00636-0168-4-ANV	VB00422-0080-5-ANV
		1	VB00722-0205-2-ANV	VB00636-0205-4-ANV	VB00422-0100-5-ANV
	IGBT	2	PP01175	PP01175	PP01127
DC section	Bus capacitor	4	S00335	S00335	PP01041
Inverter	Diode	3	CP01268	CP01268	CP01373
	Rectifier board	1	VB00227	VB00227	VB00427
Keypad ^②	SVX/SPX keypad	1	KEYPAD-LOC/REM	KEYPAD-LOC/REM	KEYPAD-LOC/REM
Main AC fan	Fan AC	1	PP01123	PP01123	PP01123
	Fan fuse	2	PP20202	PP20202	PP20202
	Starting cap	1	S00734	S00734	S00734
	Fan driver board AC	1	VB00599	VB00799	VB00799
	Isolation transformer (fan)	1	S0000113	S0000113	S0000113
Main DC fan ^②	DC fan	1	PP00071	PP00071	PP00071
	DC power supply	1	S01016	S01016	S01016
Other	Front cover, N12 ^①	1	FR08079	FR08079	FR08079
	Conduit plate, N12	1	FR08082	FR08082	FR08082
	Front cover, N1	1	FR08106	FR08106	FR08106

Notes

^① Only for NEMA Type 12/IP54 Type drives.

^② Factory recommended spare parts.

^③ Select one part number based on the amperage rating of the drive. Please contact EatonCare at 877-ETN-CARE for assistance.

FR9 Spare Parts

Category	Description	Quantity/ Drive	230V Catalog Number	480V Catalog Number	575V Catalog Number
Control fan	50 mm fan	1	PP09041	PP09041	PP09041
	80 mm fan	1	PP01068	PP01068	PP01068
Control module ^①	SPX control module	1	CPBS0000000000	CPBS0000000000	CPBS0000000000
	Standard slot A I/O card	1	OPTA9	OPTA9	OPTA9
	Standard slot B I/O card	1	OPTA2	OPTA2	OPTA2
Converter	Power module ^②	1	FR09-0261-2-ANV	FR09-0261-4-ANV	FR09-0125-5-ANV
		1	FR09-0300-2-ANV	FR09-0300-4-ANV	FR09-0144-5-ANV
		1	—	—	FR09-0170-5-ANV
	Driver board	1	S00583	S00583	S00583
	Shunt board ^②	6	—	VB00535	VB00537
		6	—	VB00536	VB00542
6		—	—	VB00543	
DC section	Balancing resistor	3	PP00052	PP00052	PP00052
	Bus capacitor	8	S00335	S00335	PP01041
	DC busbars DC-	1	FR09043	FR09043	FR09043
	DC busbars DC+	1	FR09044	FR09044	FR09044
	DC busbars connection	1	FR09045	FR09045	FR09045
	DC busbars +/- insulator	1	FR09046	FR09046	FR09046
	DC busbars -/con insulator	1	FR09047	FR09047	FR09047
Inverter	Rectifier module	1	FR09826	FR09822	FR09823
	Diode	3	CP01268	CP01268	CP01268
	Rectifier board	1	—	VB00459	VB00460
Keypad ^①	SVX/SPX keypad	1	KEYPAD-LOC/REM	KEYPAD-LOC/REM	KEYPAD-LOC/REM
Main AC fan	Fan AC	1	PP01080	PP01080	PP01080
	Fan fuse	2	PP20202	PP20202	PP20202
	Starting cap	1	S00465	S00465	S00465
	Fan driver board AC	1	VB00899	VB00399	VB00299
	Isolation transformer (fan)	1	PP09056	PP09055	PP09055
Main DC fan ^①	DC fan	1	PP00072	PP00072	PP00072
	DC power supply	1	S01017	S01017	S01017
Other	Front cover power	1	FR09012	FR09012	FR09012
	Front cover connection	1	FR09013	FR09013	FR09013
	Front power conduit	1	FR09014	FR09014	FR09014

Notes

^① Factory recommended spare parts.

^② Select one part number based on the amperage rating of the drive. Please contact EatonCare at 877-ETN-CARE for assistance.

FR10 Spare Parts

2

Category	Description	Quantity/ Drive	230V Catalog Number	480V Catalog Number	575V Catalog Number
Control	Fiber board	1	—	S00451	S00451
	ASIC board	1	—	S00457	S00457
Control fan	ASIC fan	1	—	PP01096	PP01096
Control module ①	SPX control module	1	—	CPBS0000000000	CPBS0000000000
	Standard slot A I/O card	1	—	OPTA9	OPTA9
	Standard slot B I/O card	1	—	OPTA2	OPTA2
Converter	Power module ②	1	—	FR10-0385-4-ANV	FR10-0261-5-ANV
		1	—	FR10-0460-4-ANV	FR10-0325-5-ANV
		1	—	FR10-0520-4-ANV	FR10-0385-5-ANV
		1	—	—	FR10-0416-5-ANV
	Driver board	1	—	S00450	S00450
	Driver adapter board	1	—	VB00330	VB00330
	Shunt board ②	6	—	VB00497	VB00510
		6	—	VB00498	VB00511
		6	—	VB00537	VB00545
	Covers	Top cover	1	—	FR10340
Side cover		2	—	FR10341	FR10341
DC section	Balancing resistor	2	—	PP13027	PP13028
	DC busbars kit (right)	1	—	S0000005	S0000005
	Bus capacitor	12	—	S00335	S00336
Inverter	Rectifier module	1	—	FR10823	FR10823
	Charging resistor	1	—	PP00066	PP00066
	Diode	3	—	PP01177	PP01177
	Rectifier board	1	—	S00591	S00592
Keypad ①	SVX/SPX keypad	1	—	KEYPAD-LOC/REM	KEYPAD-LOC/REM
Main AC fan	Fan assembly (left)	1	—	FR10846	FR10846
	Fan assembly (right)	1	—	FR10847	FR10847
	Fan AC	2	—	PP01080	PP01080
	Fan fuse	4	—	PP20202	PP20202
	Starting cap	2	—	S00528	S00528
	Fan driver board AC	2	—	VB00299	VB00299
	Isolation transformer (left)	1	—	FR10844	FR10844
	Isolation transformer (right)	1	—	FR10845	FR10845
Main DC fan ①	DC fan	2	—	PP00072	PP00072
	DC power supply	2	—	S01017	S01017

Notes

① Factory recommended spare parts.

② Select one part number based on the amperage rating of the drive. Please contact EatonCare at 877-ETN-CARE for assistance.

FR11 Spare Parts

Category	Description	Quantity/ Drive	230V Catalog Number	480V Catalog Number	575V Catalog Number
Control	Fiber board	1	—	S00451	S00451
	ASIC board	1	—	S00457	S00457
Control fan	ASIC fan	1	—	PP01096	PP01096
Control module ^①	SPX control module	1	—	CPBS0000000000	CPBS0000000000
	Standard slot A I/O card	1	—	OPTA9	OPTA9
	Standard slot B I/O card	1	—	OPTA2	OPTA2
Converter	Power module ^②	1	—	FR11-0590-4-ANV	FR11-0460-5-ANV
		1	—	FR11-0650-4-ANV	FR11-0502-5-ANV
		1	—	FR11-0730-4-ANV	FR11-0590-5-ANV
	Driver board	1	—	S00452	S00452
	Driver adapter board	1	—	VB00330	VB00330
	Shunt board ^②	9	—	VB00513	VB00512
		9	—	VB00514	VB00546
9		—	VB00538	VB00547	
Covers	Top cover	1	—	FR11345	FR11345
DC section	Balancing resistor	3	—	PP13027	PP13027
	DC busbars kit (right)	3	—	S0000005	S0000005
	Bus capacitor	18	—	S00335	S00335
Inverter	Rectifier module	1	—	FR10823	FR10823
	Diode	3	—	PP01177	PP01177
	Rectifier board	1	—	S00591	S00591
Keypad ^①	SVX/SPX keypad	1	—	KEYPAD-LOC/REM	KEYPAD-LOC/REM
Main AC fan	Fan assembly (right)	3	—	FR10847	FR10847
	Fan AC	3	—	PP01080	PP01080
	Fan fuse	4	—	PP20202	PP20202
	Starting cap	3	—	S00530	S00530
	Fan driver board AC	3	—	VB00299	VB00299
	Isolation transformer (right)	3	—	FR10845	FR10845
Main DC fan ^①	DC fan	2	—	PP00072	PP00072
	DC power supply	2	—	S01017	S01017

Notes

^① Factory recommended spare parts.

^② Select one part number based on the amperage rating of the drive. Please contact EatonCare at 877-ETN-CARE for assistance.

FR12 Spare Parts

2

Category	Description	Quantity/ Drive	230V Catalog Number	480V Catalog Number	575V Catalog Number
Control	Fiber board	2	—	S00451	S00451
	ASIC board	2	—	S00457	S00457
	Star coupler	1	—	S00593	S00593
Control fan	ASIC fan	2	—	PP01096	PP01096
Control module ^①	SPX control module	1	—	CPBS0000000000	CPBS0000000000
	Standard slot A I/O card	1	—	OPTA9	OPTA9
	Standard slot B I/O card	1	—	OPTA2	OPTA2
Converter	Power module ^②	1	—	FR12-0820-4-ANV	FR12-0650-5-ANV
		1	—	FR12-0920-4-ANV	FR12-0750-5-ANV
		1	—	FR12-1030-4-ANV	FR12-0820-5-ANV
	Driver board	2	—	S00450	S00450
	Driver adapter board	2	—	VB00330	VB00330
	Shunt board	12	—	VB00498	VB00511
	Covers	Top cover	2	—	FR10340
Side cover		4	—	FR10341	FR10341
DC section	Balancing resistor	4	—	PP13027	PP13027
	DC busbars kit (right)	2	—	S0000005	S0000005
	Bus capacitor	24	—	S00335	S00336
Inverter	Rectifier module	2	—	FR10823	FR10823
	Diode	3	—	PP01177	PP01177
	Rectifier board	2	—	S00591	S00591
Keypad ^①	SVX/SPX keypad	1	—	KEYPAD-LOC/REM	KEYPAD-LOC/REM
Main AC fan	Fan assembly (left)	2	—	FR10846	FR10846
	Fan assembly (right)	2	—	FR10847	FR10847
	Fan AC	4	—	PP01080	PP01080
	Fan fuse	8	—	PP20202	PP20202
	Starting cap	4	—	S00528	S00528
	Fan driver board AC	4	—	VB00299	VB00299
	Isolation transformer (left)	2	—	FR10844	FR10844
	Isolation transformer (right)	2	—	FR10845	FR10845
Main DC fan ^①	DC fan	4	—	PP00072	PP00072
	DC power supply	4	—	S01017	S01017

Notes

^① Factory recommended spare parts.

^② Select one part number based on the amperage rating of the drive. Please contact EatonCare at 877-ETN-CARE for assistance.

FR13 Spare Parts

Category	Description	Quantity/ Drive	230V Catalog Number	480V Catalog Number	575V Catalog Number
Control	ASIC board	1	—	S00457	S00457
	ASIC assembly	1	—	60S01030	60S01030
Control fan	ASIC fan	1	—	PP01096	PP01096
Control module ①	SPX control module	1	—	CPBS0000000000	CPBS0000000000
	Standard slot A I/O card	1	—	OPTA9	OPTA9
	Standard slot B I/O card	1	—	OPTA2	OPTA2
Converter	Power module ②	3	—	FI13-1150-4-ANV	FR13-1030-5-ANV
		3	—	FI13-1300-4-ANV	FR13-1180-5-ANV
		3	—	FI13-1450-4-ANV	FR13-920-5-ANV
	Driver board	3	—	S00454	S00454
	Driver adapter board	2	—	VB00330	VB00330
	Shunt board ②	18	—	VB00505	VB00516
		18	—	VB00514	VB00517
		18	—	VB00541	VB00547
Covers	Top cover	3	—	FI10001	FI10001
	Side cover	3	—	FI10003	FI10003
DC section	Balancing resistor	6	—	PP13034	PP13034
	Bus capacitor	36	—	S00335	S00336
	DC busbars kit	3	—	FI13329	FI13329
Inverter	Rectifier module	2	—	FR10823	FR10823
	Diode	3	—	PP01177	PP01177
	Rectifier board	2	—	S00591	S00591
Keypad ①	SVX/SPX keypad	1	—	KEYPAD-LOC/REM	KEYPAD-LOC/REM
Main AC fan	Fan assembly (left)	3	—	FI13301	FI13301
	Fan AC	3	—	PP01080	PP01080
	Fan fuse	6	—	PP20202	PP20202
	Starting cap	3	—	S00520	S00520
	Fan driver board AC	3	—	VB00299	VB00299
	Isolation transformer	3	—	PP10057	PP10057
Main DC fan ①	DC fan	4	—	PP00072	PP00072
	DC power supply	4	—	S01017	S01017

Notes

① Factory recommended spare parts.

② Select one part number based on the amperage rating of the drive. Please contact EatonCare at 877-ETN-CARE for assistance.

FR14 Spare Parts

2

Category	Description	Quantity/ Drive	230V Catalog Number	480V Catalog Number	575V Catalog Number
Control	ASIC board	2	—	S00457	S00457
	Star coupler	1	—	S00593	S00593
	ASIC assembly	2	—	60S01030	60S01030
	Star coupler kit	1	—	FR10860	FR10860
Control fan	ASIC fan	2	—	PP01096	PP01096
Control module ^①	SPX control module	1	—	CPBS0000000000	CPBS0000000000
	Standard slot A I/O card	1	—	OPTA9	OPTA9
	Standard slot B I/O card	1	—	OPTA2	OPTA2
Converter	Power module ^②	1	—	FR14-1770-4-ANV	FR14-1500-5-ANV
		1	—	FR14-2150-4-ANV	FR14-1900-5-ANV
		1	—	FR14-2700-4-ANV	FR14-2250-5-ANV
	Driver board	6	—	S00454	S00454
	Driver adapter board	2	—	VB00330	VB00330
	Shunt board ^②	36	—	VB00541	VB00516
		36	—	—	VB00517
Covers	Top cover	6	—	FI10001	FI10001
	Side cover	6	—	FI10003	FI10003
DC section	Balancing resistor	6	—	PP13034	PP13034
	Bus capacitor	72	—	S00335	S00336
	DC busbars kit	6	—	FI13329	FI13329
Inverter	Rectifier module	2	—	FR10823	FR10823
	Diode	3	—	PP01177	PP01177
	Rectifier board	2	—	S00591	S00591
Keypad ^①	SVX/SPX keypad	1	—	KEYPAD-LOC/REM	KEYPAD-LOC/REM
Main AC fan	Fan assembly (left)	6	—	FI13301	FI13301
	Fan AC	6	—	PP01080	PP01080
	Fan fuse	12	—	PP20202	PP20202
	Starting cap	6	—	S00520	S00520
	Fan driver board AC	6	—	VB00299	VB00299
	Isolation transformer	6	—	PP10057	PP10057
Main DC fan ^①	DC fan	6	—	PP00072	PP00072
	DC power supply	6	—	S01017	S01017

Notes

^① Factory recommended spare parts.

^② Select one part number based on the amperage rating of the drive. Please contact EatonCare at 877-ETN-CARE for assistance.

Technical Data and Specifications

SPX9000 Drives

Description	Specification
Input Ratings	
Input voltage (V_{in})	+10%/-15%
Input frequency (f_{in})	50/60 Hz (variation up to 45–66 Hz)
Connection to power	Once per minute or less (typical operation)
High withstand rating	100 kAIC
Output Ratings	
Output voltage	0 to V_{in}
Continuous output current	I_H rated 100% at 122°F (50°C), FR9 and below I_L rated 100% at 104°F (40°C), FR9 and below I_H/I_L 100% at 104°F (40°C), FR10 and above
Overload current (I_H/I_L)	150% I_H , 110% I_L for 1 min.
Output frequency	0 to 320 Hz
Frequency resolution	0.01 Hz
Initial output current (I_H)	250% for 2 seconds
Control Characteristics	
Control method	Frequency control (V/f) Open loop: sensorless vector control Closed loop: frequency control Closed loop: vector control
Switching frequency	Adjustable with parameter 2.6.9
Frame 4–6	1 to 16 kHz; default 10 kHz
Frame 7–12	1 to 10 kHz; default 3.6 kHz
Frequency reference	Analog input: Resolution 0.1% (10-bit), accuracy $\pm 1\%$ V/Hz Panel reference: Resolution 0.01 Hz
Field weakening point	30 to 320 Hz
Acceleration time	0 to 3000 sec.
Deceleration time	0 to 3000 sec.
Braking torque	DC brake: 30% $\times T_n$ (without brake option)
Ambient Conditions	
Ambient operating temperature	14°F (-10°C), no frost to 122°F (50°C) I_H (FR4–FR9) 14°F (-10°C), no frost to 104°F (40°C) I_L (FR10 and up) 14°F (-10°C), no frost to 104°F (40°C) I_L (all frames)
Storage temperature	-40° to 158°F (-40° to 70°C)
Relative humidity	0 to 95% RH, noncondensing, non-corrosive, no dripping water
Air quality	Chemical vapors: IEC 721-3-3, unit in operation, class 3C2; Mechanical particles: IEC 721-3-3, unit in operation, class 3S2
Altitude	100% load capacity (no derating) up to 3280 ft (1000m); 1% derating for each 328 ft (100m) above 3280 ft (1000m); max. 9842 ft (3000m)
Vibration	EN 50178, EN 60068-2-6; 5 to 50 Hz, displacement amplitude 1 mm (peak) at 3 to 15.8 Hz, max. acceleration amplitude 1G at 15.8 to 150 Hz
Shock	EN 50178, EN 60068-2-27 UPS Drop test (for applicable UPS weights) Storage and shipping: max. 15G, 11 ms (in package)
Enclosure class	NEMA 1/IP21 or NEMA 12/IP54, open chassis/IP20

Description	Specification
Control Connections	
Analog input voltage	0 to 10V, R = 200 kohms (-10 to 10V joystick control) resolution 0.1%; accuracy $\pm 1\%$
Analog input current	0(4) to 20 mA; R_T —250 ohms differential
Digital inputs (6)	Positive or negative logic; 18 to 30 Vdc
Auxiliary voltage	+24V $\pm 15\%$, max. 250 mA
Output reference voltage	+10V $+3\%$, max. load 10 mA
Analog output	0(4) to 20 mA; R_L max. 500 ohms; resolution 10 bit; Accuracy $\pm 2\%$
Digital outputs	Open collector output, 50 mA/48V
Relay outputs	2 programmable Form C relay outputs switching capacity: 24 Vdc/8A, 250 Vac/8A, 125 Vdc/0.4A
Protections	
Overcurrent protection	Trip limit 4.0 $\times I_H$ instantaneously
Overvoltage protection	Yes
Undervoltage protection	Yes
Earth fault protection	In case of earth fault in motor or motor cable, only the frequency converter is protected
Input phase supervision	Trips if any of the input phases are missing
Motor phase supervision	Trips if any of the output phases are missing
Overtemperature protection	Yes
Motor overload protection	Yes
Motor stall protection	Yes
Motor underload protection	Yes
Short-circuit protection	Yes (+24V and +10V reference voltages)
High Performance Features	
Speed error	<0.01%, depending on the encoder
Encoder support	Incremental or absolute
Encoder voltages	5V (RS-422), 15V or 24V, depending on the option card
Torque control	Full torque control at all speeds, including zero
Torque accuracy	<2%; <5% down to zero speed
Starting torque	>200%, depending on motor and drive sizing
Master/slave configurations	Full capability
System analysis	Integrated data logger
PC communication	Fast multiple drive monitoring with PC
Inter-drive communication	High-speed bus (12 Mbits/s)
High-speed applications	Up to 7200 Hz

2.7

Adjustable Frequency Drives

SPX9000 Drives

Dimensions

Approximate Dimensions in Inches (mm)

2

9000X Drives

NEMA Type 1/IP21 and NEMA Type 12/IP54, FR4, FR5 and FR6

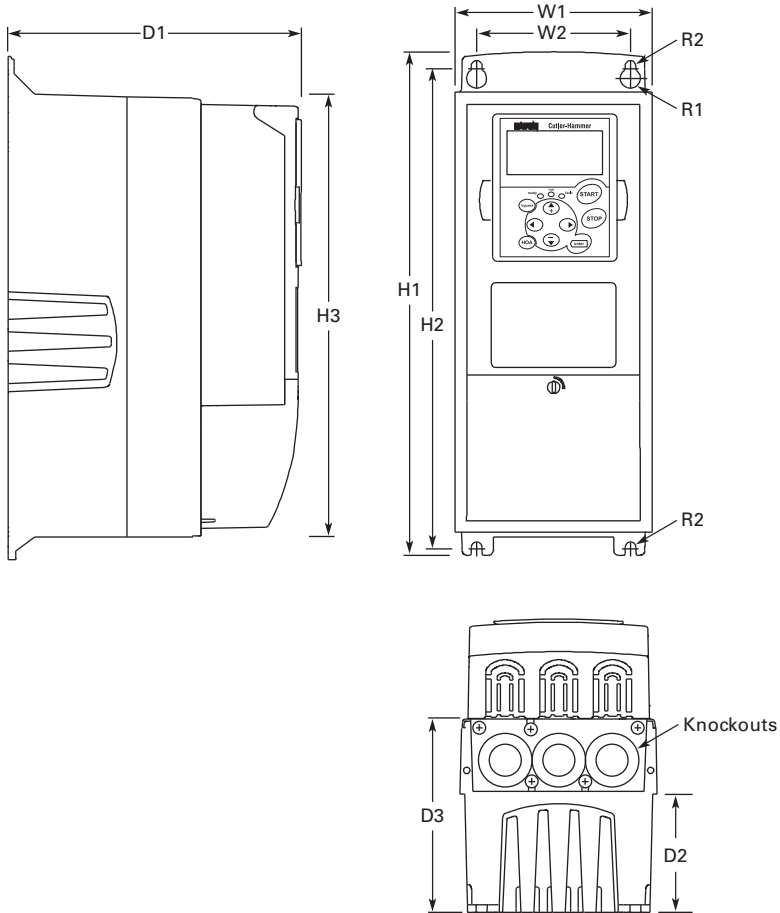

Voltage	hp (I _H)	H1	H2	H3	D1	D2	D3	W1	W2	R1 Dia.	R2 Dia.	Weight Lbs (kg)	Knockouts at Inches (mm) N1 (O.D.)
FR4													
230V	3/4-3	12.9	12.3	11.5	7.5	3.0	5.0	5.04	3.9	0.5	0.3	11.0 (5)	3 at 10.1 (28)
480V	1-5	(327)	(313)	(292)	(190)	(77)	(126)	(128)	(100)	(13)	(7)		
FR5													
230V	5-7-1/2	16.5	16.0	15.3	8.4	3.9	5.8	5.7	3.9	0.5	0.3	17.9 (8)	2 at 1.5 (37)
480V	7-1/2-15	(419)	(406)	(389)	(214)	(100)	(148)	(144)	(100)	(13)	(7)		1 at 10.1 (28)
FR6													
230V	10-15	22.0	21.3	20.4	9.3	4.2	6.5	7.7	5.8	0.6	0.4	40.8 (19)	3 at 1.5 (37)
480V	20-30	(558)	(541)	(519)	(237)	(105)	(165)	(195)	(148)	(15.5)	(9)		
575V	2-25												

Approximate Dimensions in Inches (mm)

NEMA Type 1/IP21 and NEMA Type 12/IP54 with Flange Kit, FR4, FR5 and FR6

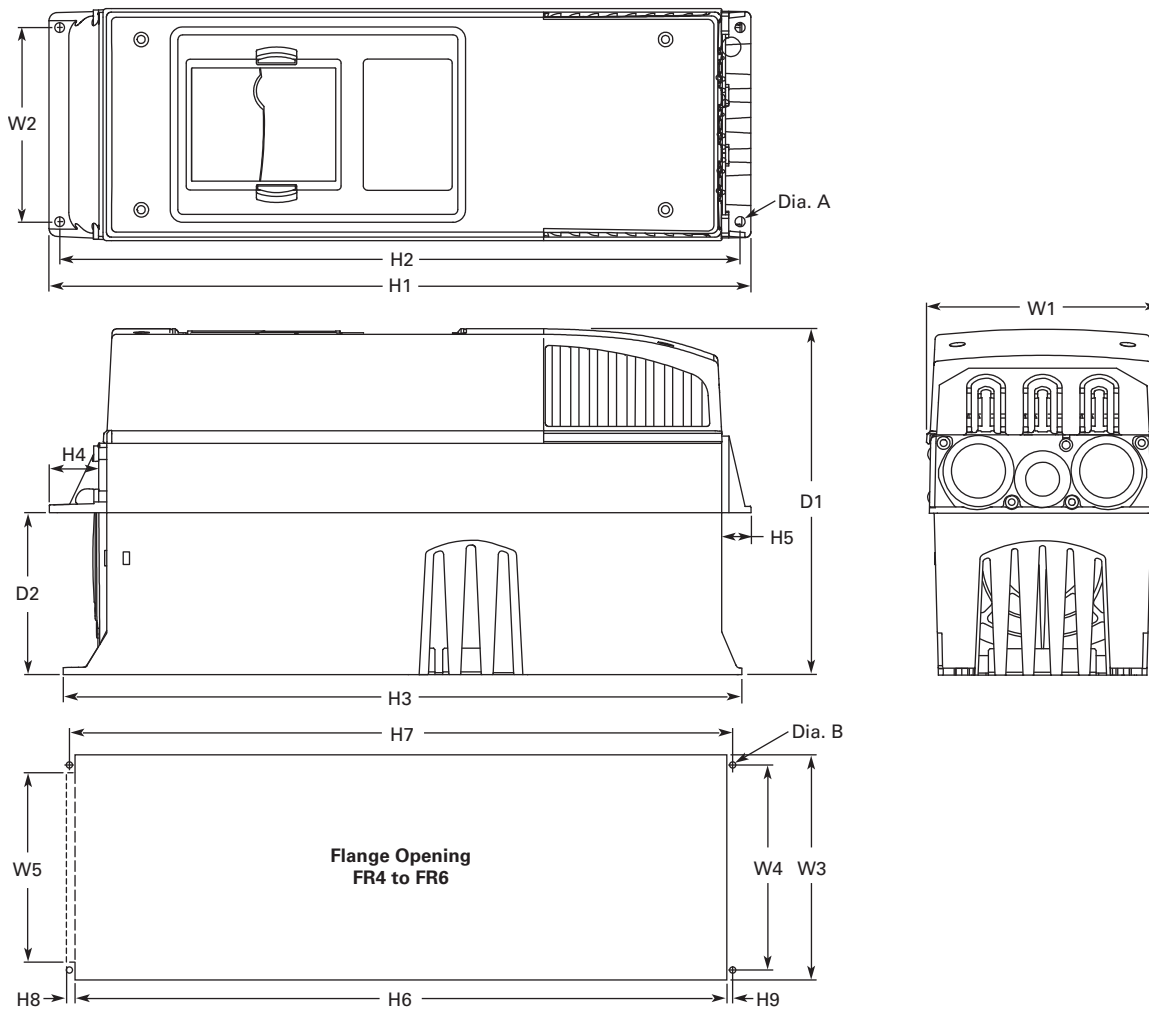

FR4, FR5 and FR6 with Flange Kit

W1	W2	H1	H2	H3	H4	H5	D1	D2	Dia. A
FR4									
5.0 (128)	4.5 (113)	13.3 (337)	12.8 (325)	12.9 (327)	1.2 (30)	0.9 (22)	7.5 (190)	3.0 (77)	0.3 (7)
FR5									
5.6 (143)	4.7 (120)	17.0 (434)	16.5 (420)	16.5 (419)	1.4 (36)	0.7 (18)	8.4 (214)	3.9 (100)	0.3 (7)
FR6									
7.7 (195)	6.7 (170)	22.0 (560)	21.6 (549)	22.0 (558)	1.2 (30)	0.8 (20)	9.3 (237)	4.2 (106)	0.3 (7)

Flange Opening, FR4 to FR6

W3	W4	W5	H6	H7	H8	H9	Dia. B
FR4							
4.8 (123)	4.5 (113)	—	12.4 (315)	12.8 (325)	—	0.2 (5)	0.3 (7)
FR5							
5.3 (135)	4.7 (120)	—	16.2 (410)	16.5 (420)	—	0.2 (5)	0.3 (7)
FR6							
7.3 (185)	6.7 (170)	6.2 (157)	21.2 (539)	21.6 (549)	0.3 (7)	0.2 (5)	0.3 (7)

2.7

Adjustable Frequency Drives

SPX9000 Drives

Approximate Dimensions in Inches (mm)

NEMA Type 1/IP21 and NEMA Type 12/IP54, FR7

2

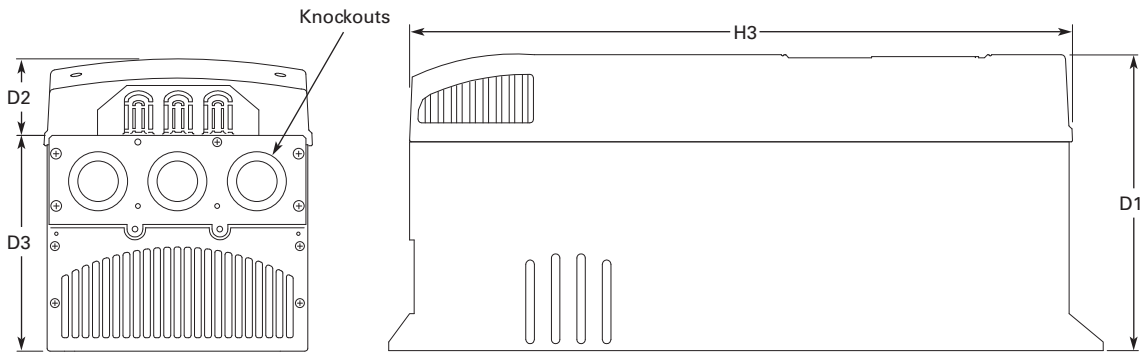
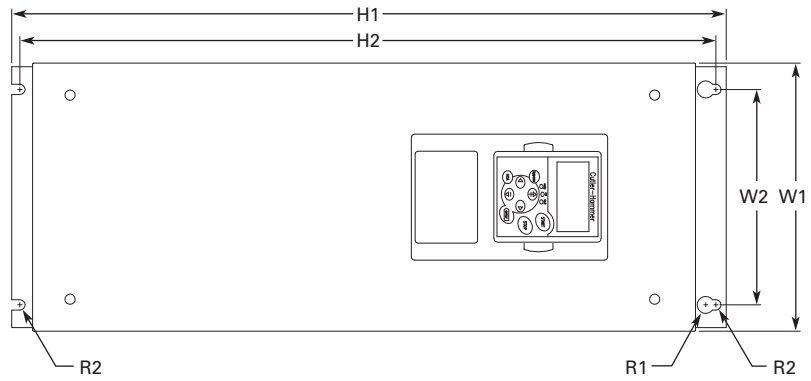

Voltage	hp (I _H)	H1	H2	H3	D1	D2	D3	W1	W2	R1 Dia.	R2 Dia.	Weight Lbs (kg)	Knockouts at Inches (mm) N1 (O.D.)
230V	20–30	24.8 (630)	24.2 (614)	23.2 (590)	10.1 (257)	3.0 (77)	7.3 (184)	9.3 (237)	7.5 (190)	0.7 (18)	0.4 (9)	77.2 (35)	3 at 1.5 (37)
480V	40–60												
575V	30–40												

Approximate Dimensions in Inches (mm)

NEMA Type 1/IP21 and NEMA Type 12/IP54, FR8

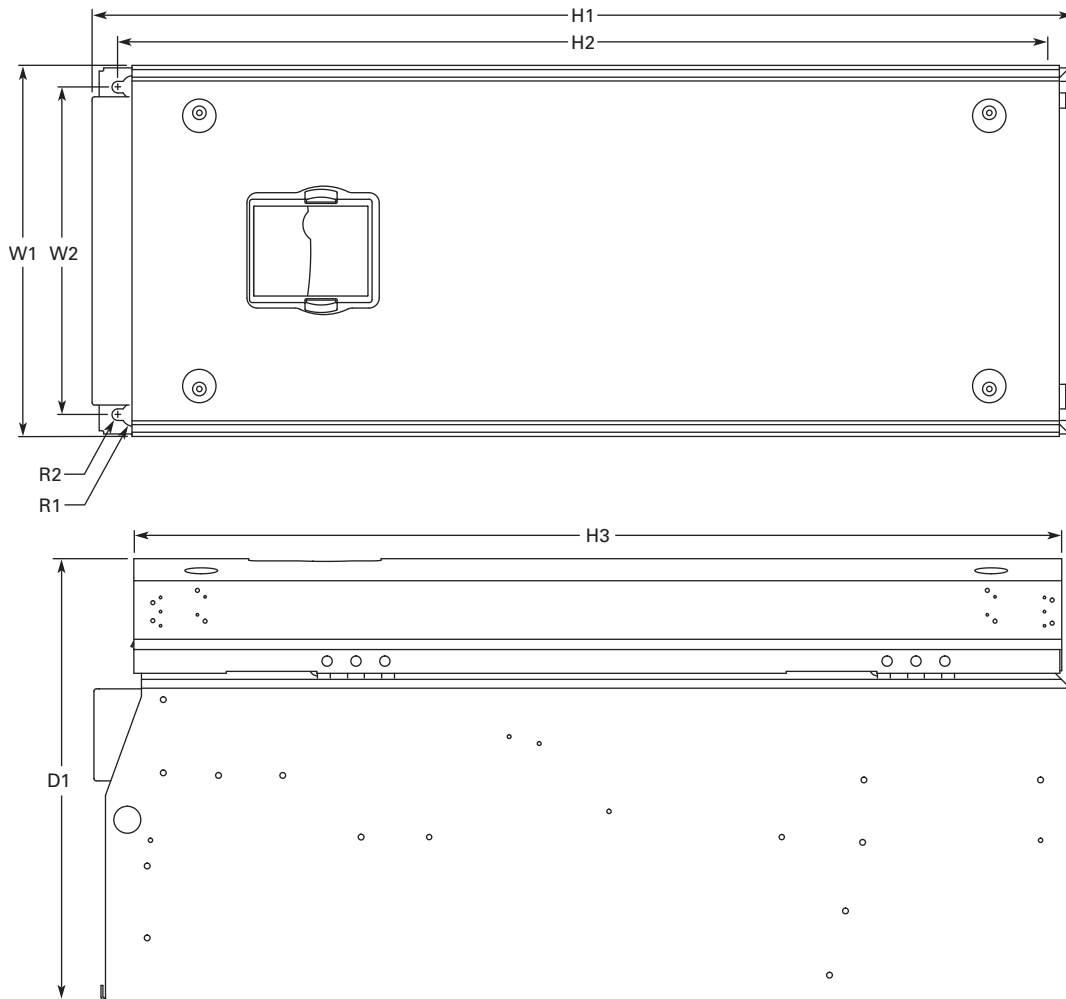

Voltage	hp (I _H)	D1	H1	H2	H3	W1	W2	R1 Dia.	R2 Dia.	Weight Lbs (kg)
230V	40–60	13.5 (344)	300.1 (764)	28.8 (732)	28.4 (721)	11.5 (291)	10 (255)	0.7 (18)	0.4 (9)	127 (58)
480V	75–125									
575V	50–75									

2.7

Adjustable Frequency Drives

SPX9000 Drives

Approximate Dimensions in Inches (mm)

NEMA Type 1/IP21 and NEMA Type 12/IP54, with Flange Kit, FR7 and FR8

2

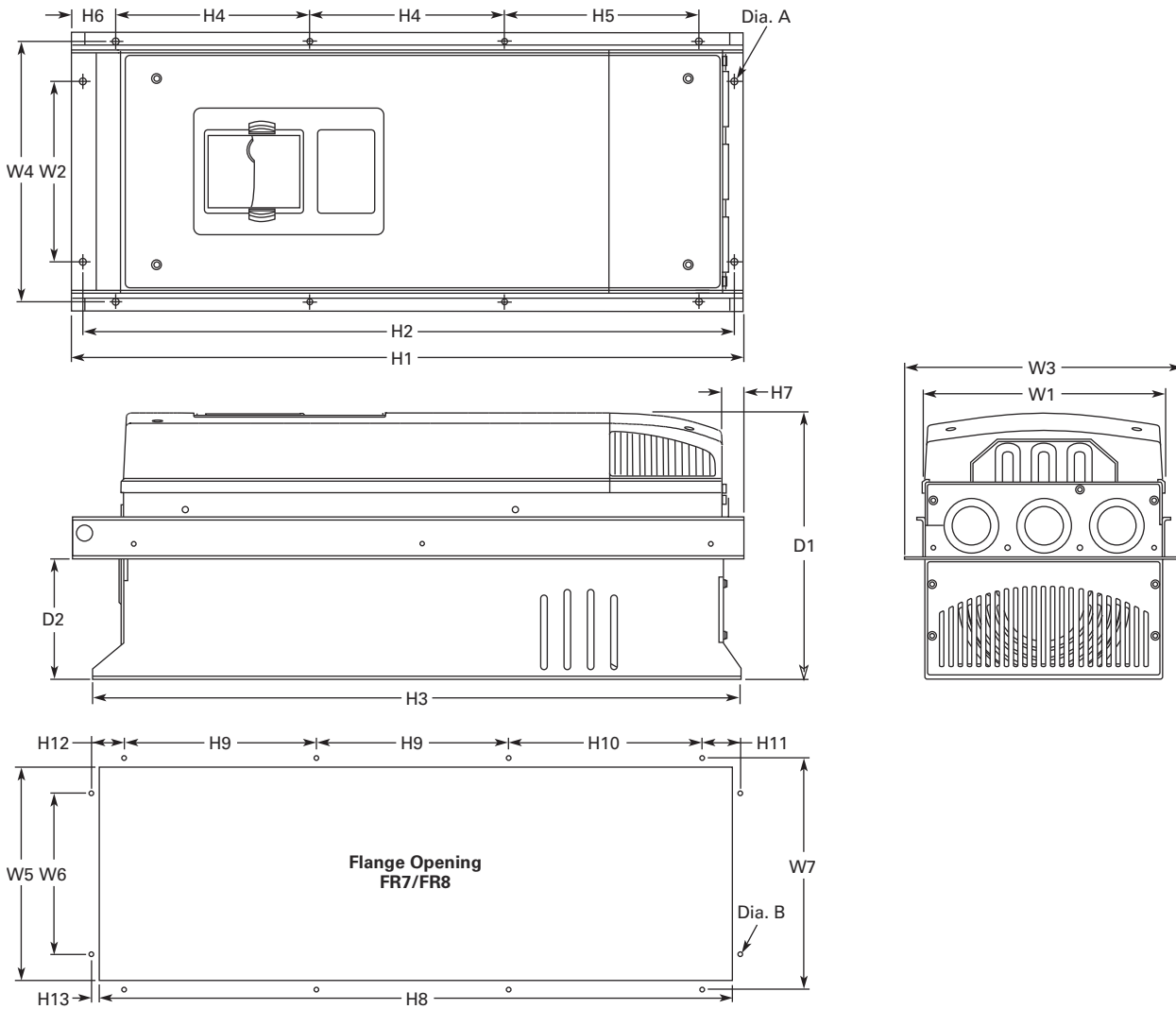

W1	W2	W3	W4	H1	H2	H3	H4	H5	H6	H7	D1	D2	Dia. A
FR7													
9.3 (237)	6.8 (175)	10.6 (270)	10.0 (253)	25.6 (652)	24.9 (632)	24.8 (630)	7.4 (189)	7.4 (189)	0.9 (23)	0.8 (20)	10.1 (257)	4.6 (117)	0.3 (6)
FR8													
11.2 (285)	—	14.0 (355)	13.0 (330)	32.8 (832)	—	29.3 (745)	10.2 (258)	10.4 (265)	1.7 (43)	2.2 (57)	13.5 (344)	4.3 (110)	0.4 (9)

Flange Opening, FR7 and FR8

W5	W6	W7	H8	H9	H10	H11	H12	H13	Dia. B
FR7									
9.2 (233)	6.9 (175)	10.0 (253)	24.4 (619)	7.4 (189)	7.4 (189)	1.4 (35)	1.3 (32)	1.0 (25)	0.3 (6)
FR8									
11.9 (301)	—	13.0 (330)	31.9 (810)	10.2 (258)	10.4 (265)	—	—	1.3 (33)	0.4 (9)

Approximate Dimensions in Inches (mm)

NEMA Type 1/IP21 and NEMA Type 12/IP54, FR9

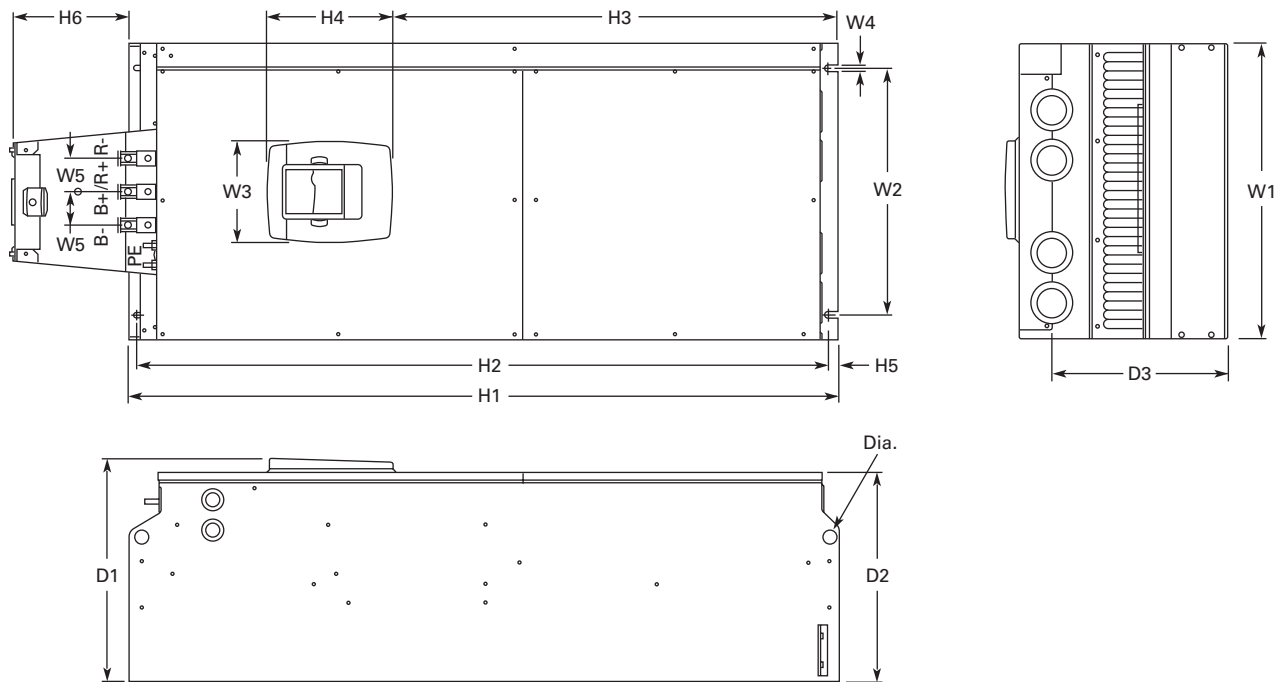

Voltage	hp (I _H)	W1	W2	W3	W4	H1	H2	H3	H4 ^①	D1	D2	D3	Dia.	Weight Lbs (kg)
230V	75–100	18.9 (480)	15.7 (400)	0.4 (9)	2.1 (54)	45.3 (1150)	44.1 (1120)	0.6 (16)	7.4 (188)	14.2 (361.5)	13.4 (340)	11.2 (285)	0.8 (21)	321.9 (146)
480V	150–200													
575V	100–175													

Note

① Brake resistor terminal box (H6) included when brake chopper ordered.

2.7

Adjustable Frequency Drives

SPX9000 Drives

Approximate Dimensions in Inches (mm)

NEMA Type 1/IP21 and NEMA Type 12/IP54, FR9 with Flange Kit

2

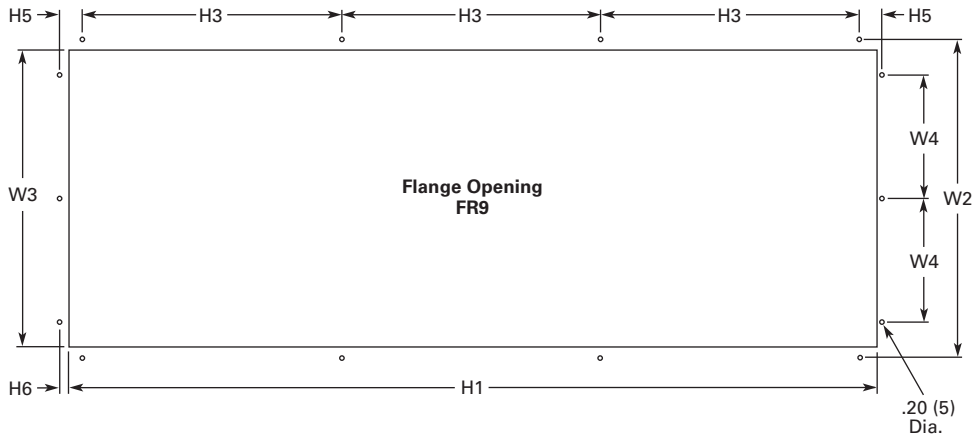
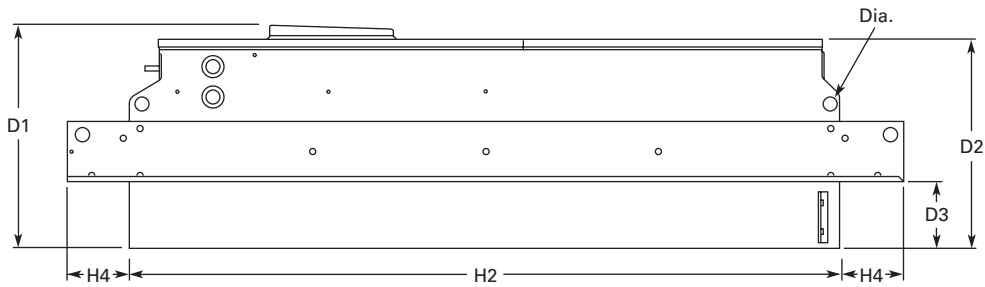
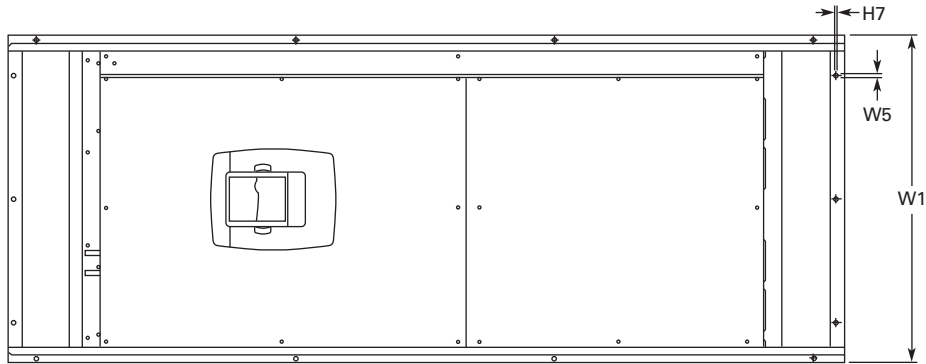

W1	W2	W3	W4	W5	H1	H2	H3	H4	H5	H6	H7	D1	D2	D3	Dia.
20.9 (530)	20.0 (510)	19.1 (485)	7.9 (200)	0.2 (5.5)	51.7 (1312)	45.3 (1150)	16.5 (420)	3.9 (100)	1.4 (35)	0.4 (9)	0.1 (2)	24.9 (362)	13.4 (340)	4.3 (109)	0.8 (21)

Approximate Dimensions in Inches (mm)

NEMA Type 1/IP21 and NEMA Type 12/IP54, FR10 Freestanding

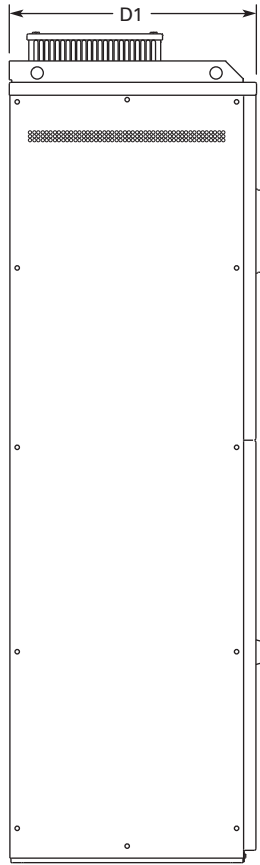
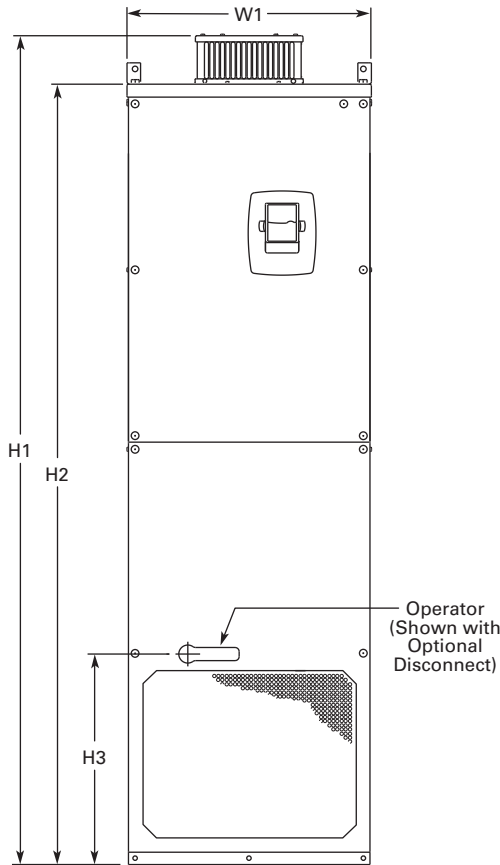
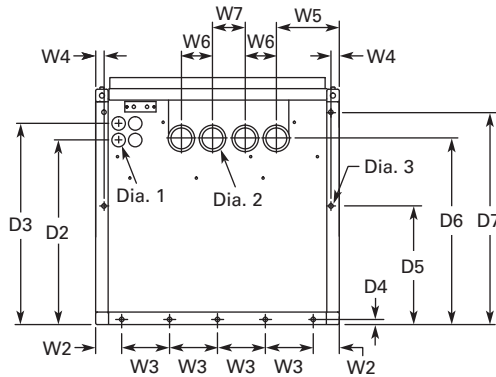
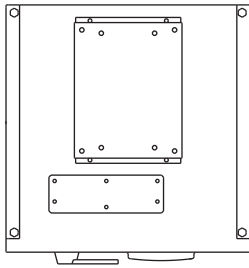

Volts	hp (I _H)	W1	W2	W3	W4	W5	W6	W7	H1	H2	H3	D1	D2	D3	D4	D5	D6	D7	Dia. 1	Dia. 2	Dia. 3	Weight Lbs (kg)
480V	250-350	23.43	2.46	4.53	0.79	5.95	2.95	30.11	79.45	74.80	20.18	23.70	17.44	19.02	0.47	11.22	17.60	20.08	0.83	1.89	0.43	875 (389)
690V	200-300	(595)	(62.5)	(115)	(20)	(151)	(75)	(79)	(2018)	(1900)	(512.5)	(602)	(443)	(483)	(12)	(285)	(447)	(510)	(21)	(48)	(11)	

2.7

Adjustable Frequency Drives

SPX9000 Drives

Approximate Dimensions in Inches (mm)

FR10 Open Chassis ①

2

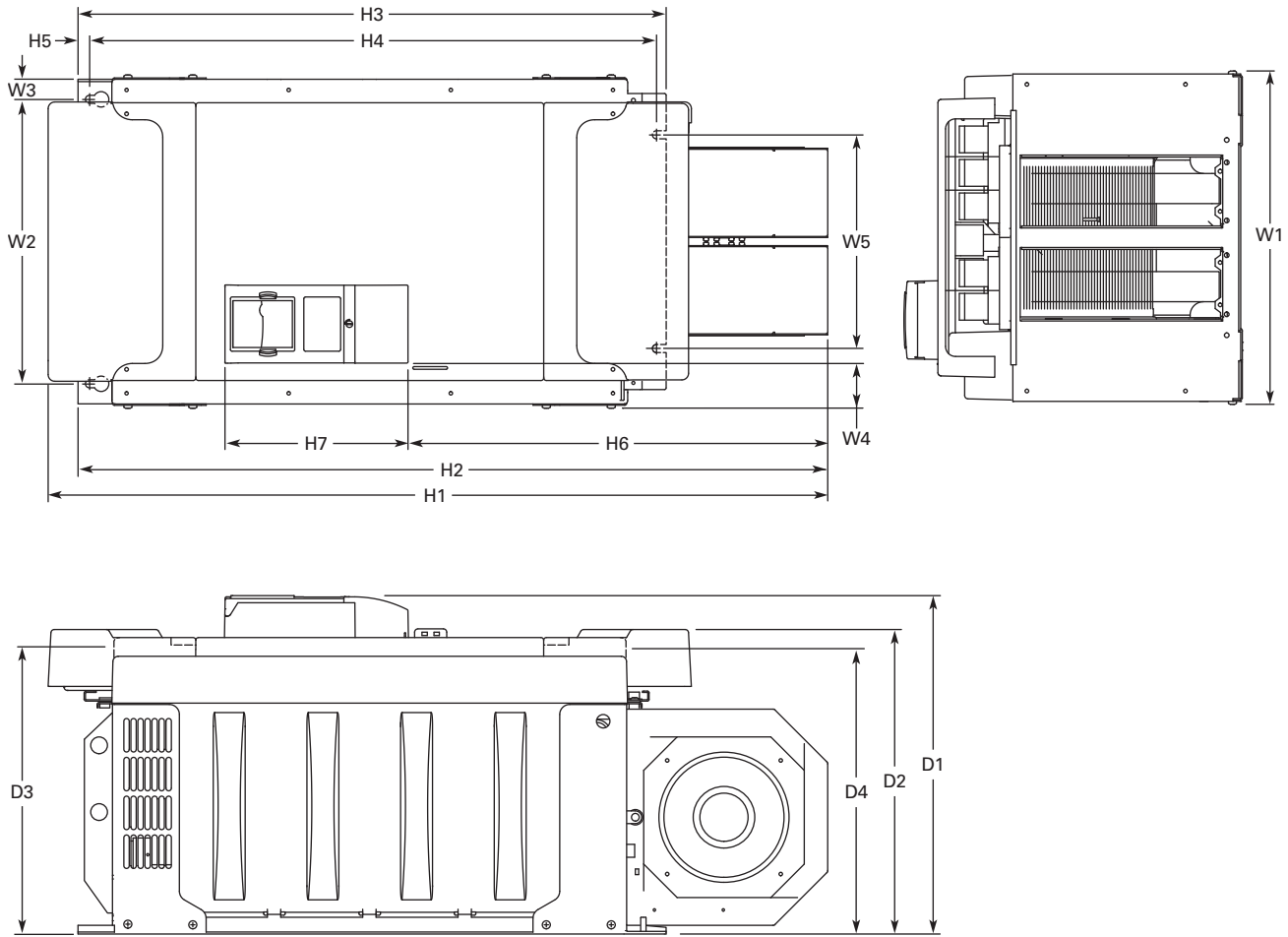

Voltage	hp (I _H)	W1	W2	W3	W4	W5	H1	H2	H3	H4	H5	H6	H7	D1	D2	D3	D4	Weight Lbs (kg)
480V	250–350	19.7	16.7	1.2	2.6	12.8	45.9	44.1	34.6	33.5	0.7	24.7	10.8	19.9	17.9	16.7	16.6	518
575V	200–300	(500)	(425)	(30)	(67)	(325)	(1165)	(1121)	(879)	(850)	(17)	(627)	(275)	(506)	(455)	(423)	(421)	(235)

Note

① SPX9000X FR12 is built of two FR10 modules. Please refer to SPX9000 installation manual for mounting instructions.

Approximate Dimensions in Inches (mm)

NEMA Type 1/IP21, FR11 Freestanding Drive

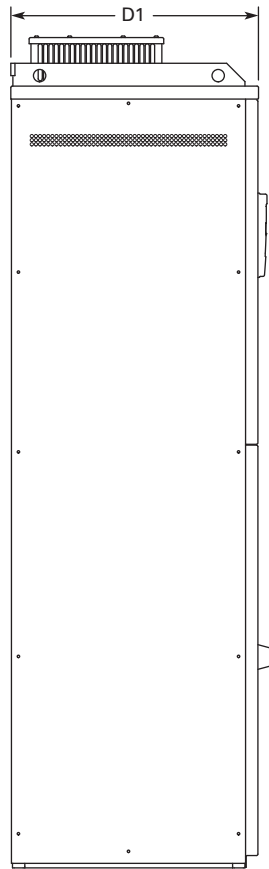
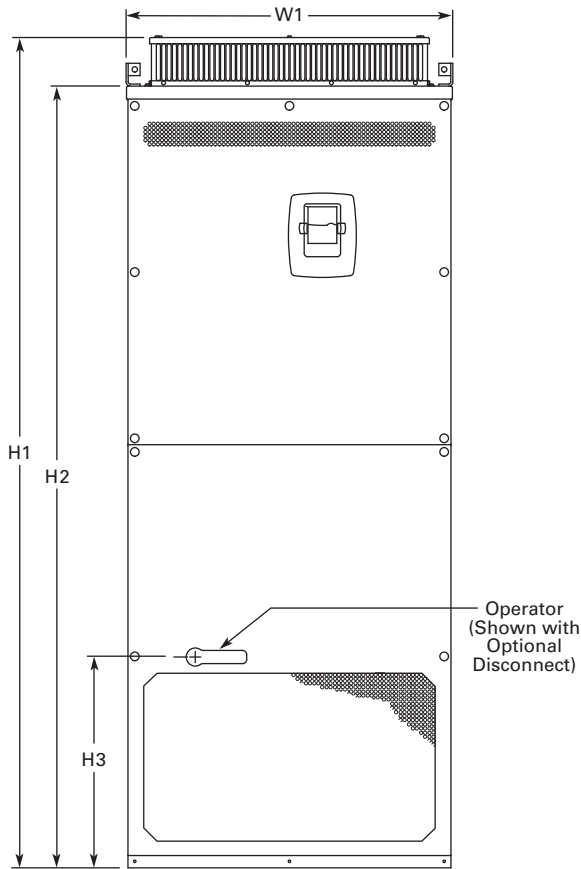
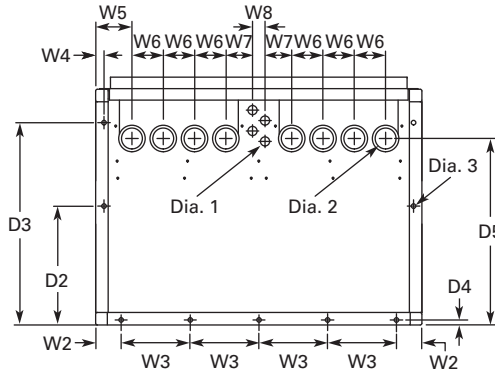
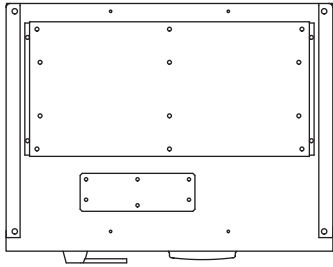

Voltage	hp (I _H)	W1	W2	W3	W4	W5	W6	W7	W8	H1	H2	H3	D1	D2	D3	D4	D5	Dia. 1	Dia. 2	Dia. 3	Weight Lbs (kg)
480V	400-550	31.26 (794)	2.40 (61)	6.50 (165)	0.79 (20)	3.43 (87)	2.95 (75)	2.52 (64)	1.18 (30)	79.45 (2018)	74.80 (1900)	20.18 (512.5)	23.70 (602)	11.22 (285)	19.09 (485)	0.47 (12)	17.60 (447)	0.83 (21)	1.89 (48)	0.35 x 0.43 (9 x 11)	526 (239)
690V	400-500																				

2.7

Adjustable Frequency Drives

SPX9000 Drives

Approximate Dimensions in Inches (mm)

FR11 Open Chassis

2

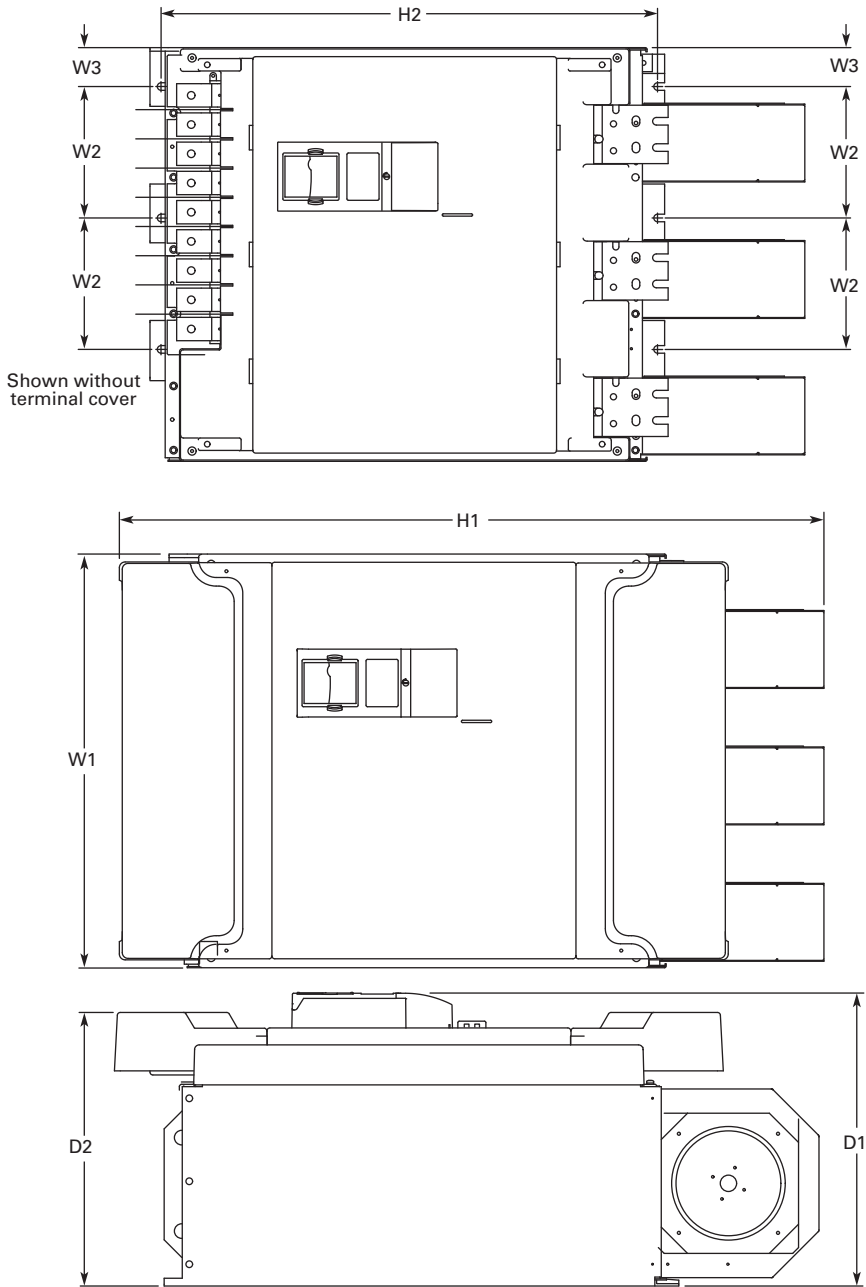

Voltage	hp (I _H)	W1	W2	W3	H1	H2	D1	D2	Weight Lbs (kg)
480V	400-550	27.9 (709)	8.6 (225)	2.6 (67)	45.5 (1155)	33.5 (850)	19.8 (503)	18.4 (468)	833 (378)
575V	400-500								

Approximate Dimensions in Inches (mm)

FR13, Open Chassis Inverter

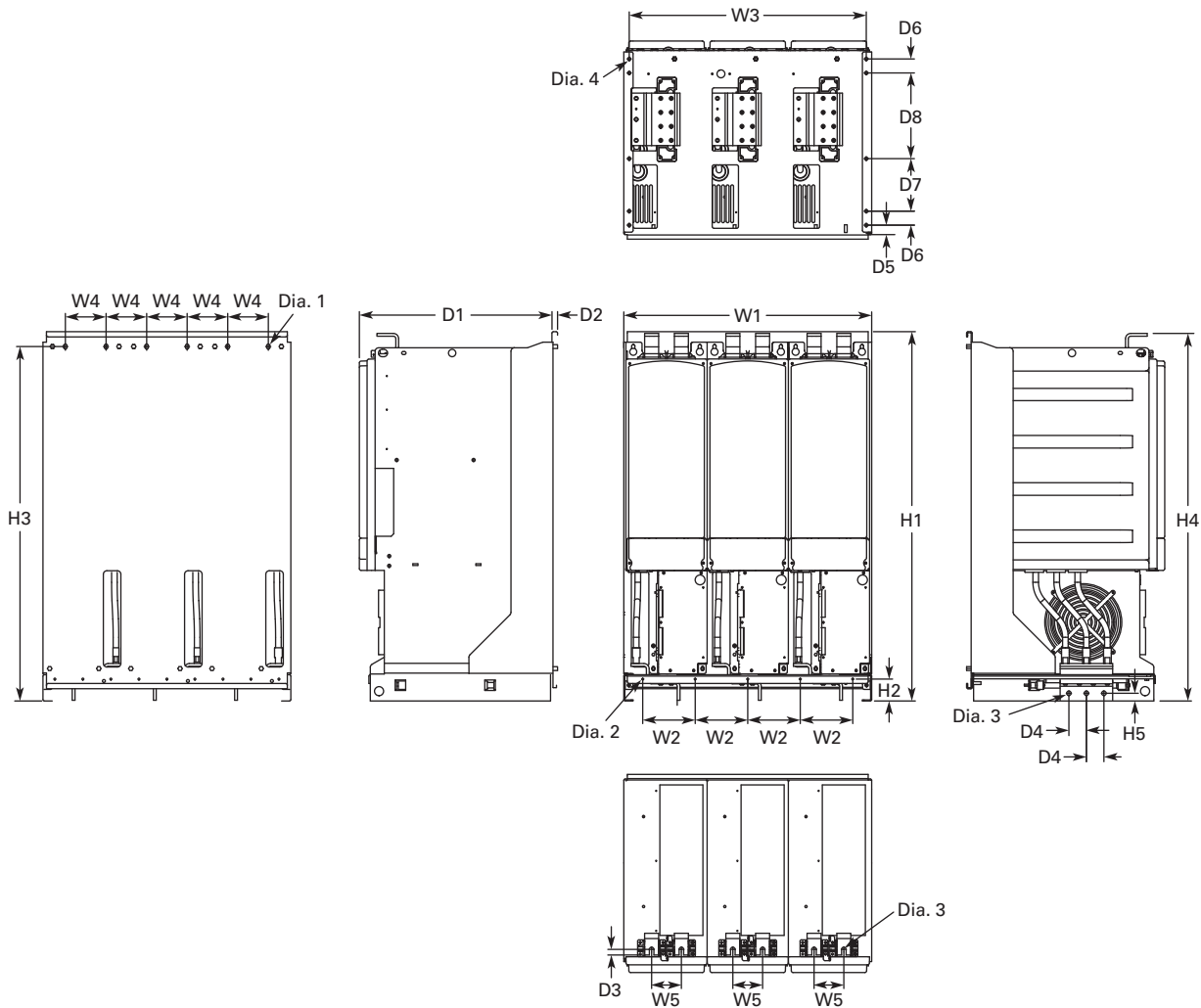

W1	W2	W3	W4	W5	H1	H2	H3	H4	H5	D1	D2	D3	D4	D5	D6	D7	D8	Dia. 1	Dia. 2	Dia. 3	Dia. 4	Weight Lbs (kg)
27.87 (708)	5.91 (150)	26.65 (677)	4.57 (116)	3.35 (85)	41.54 (1055)	2.46 (62.5)	39.86 (1012.5)	41.34 (1050)	0.79 (20)	21.77 (553)	0.51 (13)	0.63 (16)	1.97 (50)	1.06 (27)	1.57 (40)	5.91 (150)	9.64 (244.8)	0.35x0.59 (9x15)	0.18 (4.6)	0.51 (13)	0.37 (9.5)	683 (310)

Notes

9000X FR14 is built of two FR13 modules. Please refer to SPX9000 installation manual for mounting instructions.
 FR13 is built from an inverter module and a converter module. Please refer to SPX9000 installation manual for mounting instructions.

2.7

Adjustable Frequency Drives

SPX9000 Drives

Approximate Dimensions in Inches (mm)

FR13, Open Chassis Converter

2

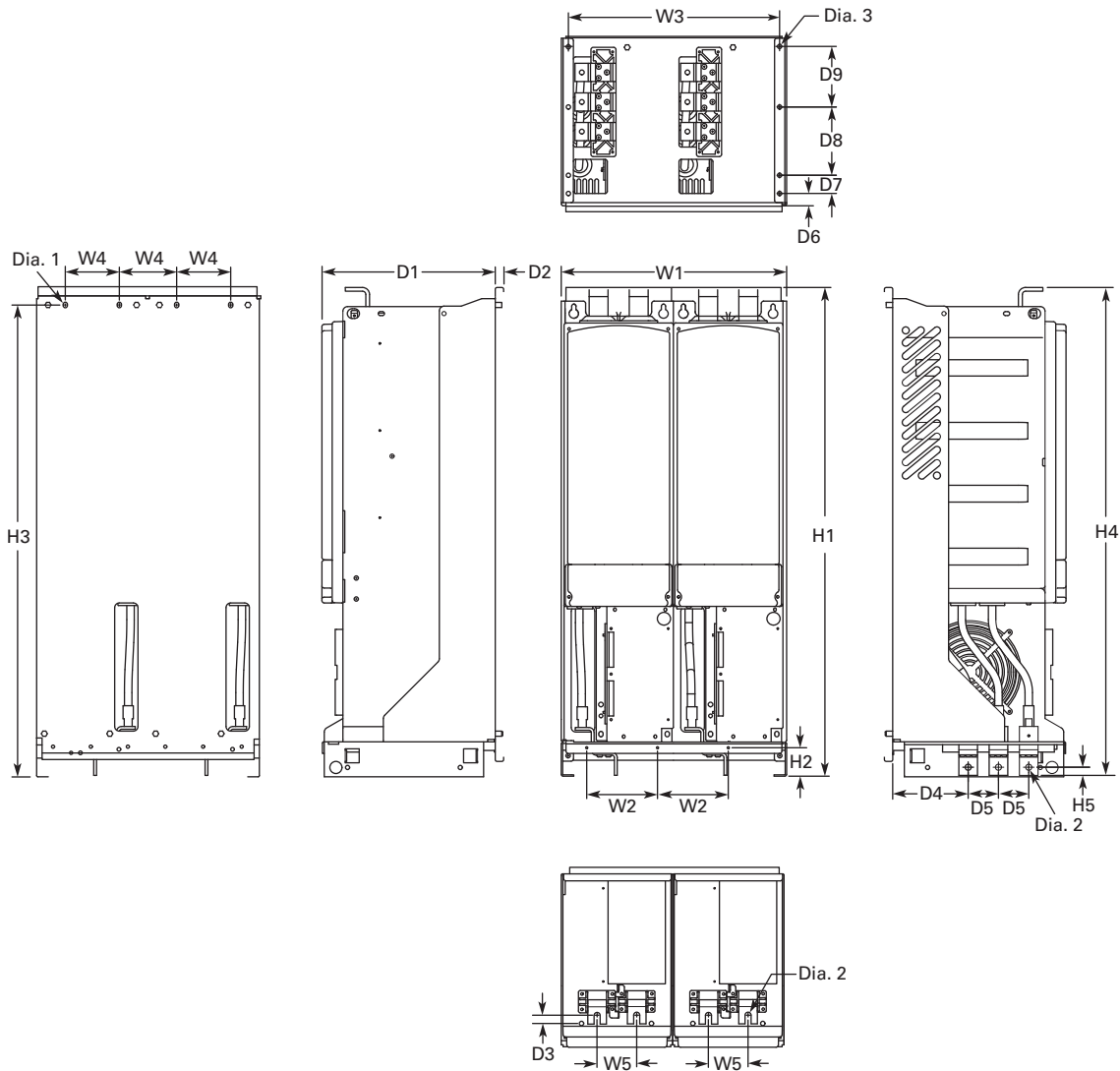

W1	W2	W3	W4	W5	H1	H2	H3	H4	H5	D1	D2	D3	D4	D5	D6	D7	D8	D9	Dia. 1	Dia. 2	Dia. 3	Weight Lbs (kg)
18.74 (476)	5.91 (150)	17.52 (445)	4.57 (116)	3.35 (85)	41.54 (1055)	2.46 (62.5)	39.86 (1012.5)	41.34 (1050)	0.69 (17.5)	14.69 (373)	0.51 (13)	0.73 (18.5)	6.42 (163)	2.56 (65)	1.06 (27)	1.57 (40)	5.91 (150)	5.24 (133)	0.35x0.59 (9x15)	0.51 (13)	0.37 (9.5)	295 (134)

Number of Input Units

480V Catalog Number	hp	Input Modules
SPX800A0-4A2N1	800	2

690V Catalog Number	hp	Input Modules
SPX800A0-5A2N1	800	2
SPX900A0-5A2N1	900	2
SPXH10A0-5A2N1	1000	2

Approximate Dimensions in Inches (mm)

FR13, Open Chassis Converter—900/1000 hp 480V

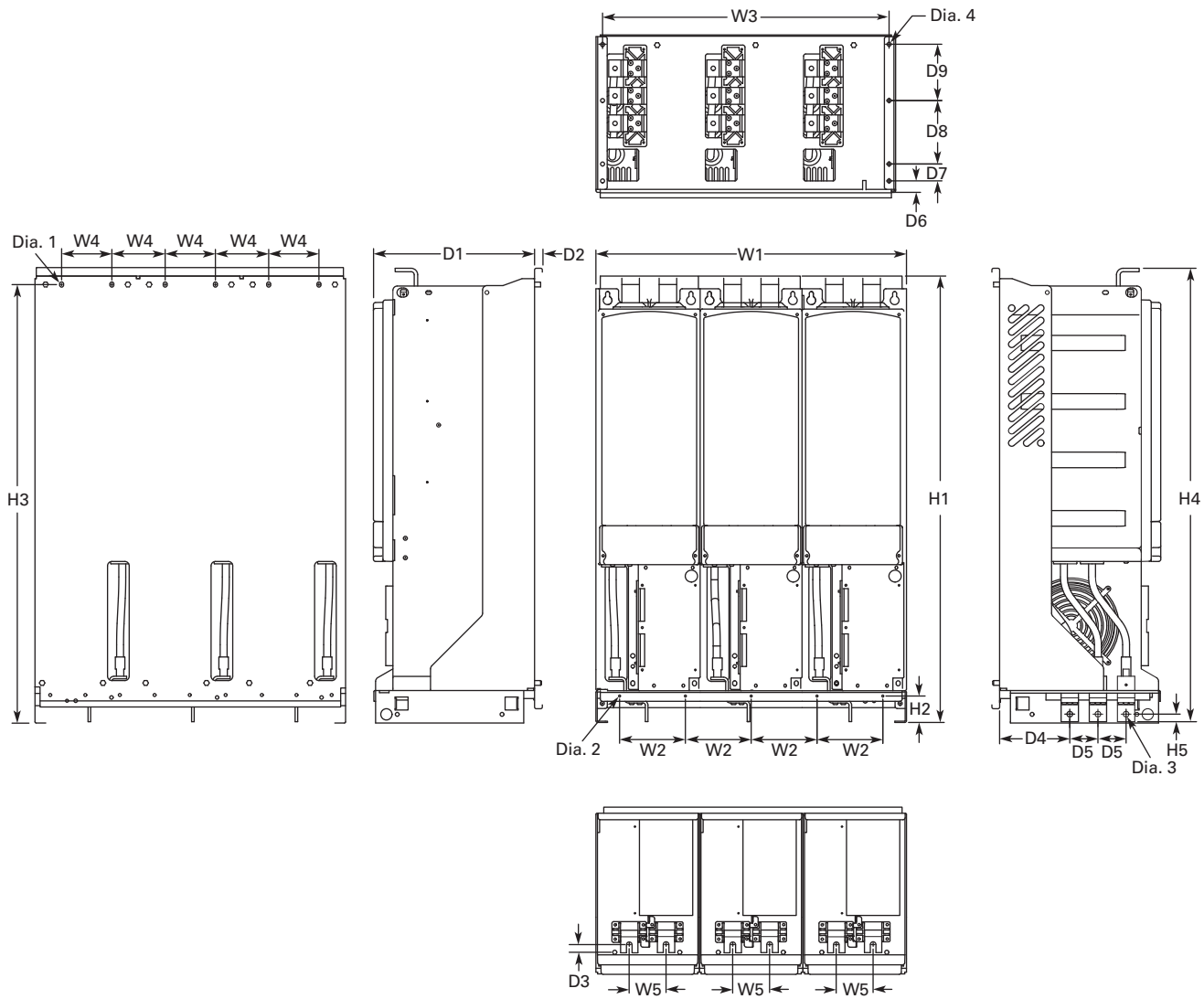

W1	W2	W3	W4	W5	H1	H2	H3	H4	H5	D1	D2	D3	D4	D5	D6	D7	D8	D9	Dia. 1	Dia. 2	Dia. 3	Dia. 4	Weight Lbs (kg)
27.87 (708)	5.91 (150)	26.65 (677)	4.57 (116)	3.35 (85)	41.54 (1055)	2.46 (62.5)	39.86 (1012.5)	41.34 (1050)	0.69 (17.5)	14.69 (373)	0.51 (13)	0.73 (18.5)	6.42 (163)	2.56 (65)	1.06 (27)	1.57 (40)	5.91 (150)	5.24 (133)	0.35x0.59 (9x15)	0.18 (4.6)	0.51 (13)	0.37 (9.5)	443 (201)

Number of Input Units

480V Catalog Number	hp	Input Modules
SPX900A0-4A2N1	900	3
SPXH10A0-4A2N1	1000	3

2.7

Adjustable Frequency Drives

SPX9000 Drives

Approximate Dimensions in Inches (mm)

2

AC Choke Dimensions

Choke Types

Catalog Number	Frame Size	Choke Type ①	Catalog Number	Frame Size	Choke Type ①
Voltage Range 380–500V			Voltage Range 525–690V		
SPX 250 4	FR10	CHK0400	SPX 200 5	FR10	CHK0261
SPX 300 4		CHK0520	SPX 250 5		CHK0400
SPX 350 4		CHK0520	SPX 300 5		CHK0400
SPX 400 4	FR11	2 x CHK0400	SPX 400 5	FR11	CHK0520
SPX 500 4		2 x CHK0400	SPX 450 5		CHK0520
SPX 550 4		2 x CHK0400	SPX 500 5		2 x CHK0400
SPX 600 4	FR12	2 x CHK0520	SPX 550 5	FR12	2 x CHK0400
SPX 650 4		2 x CHK0520	SPX 600 5		2 x CHK0400
SPX 700 4		2 x CHK0520	SPX 700 5		2 x CHK0400
SPX 800 4	FR13	2 x CHK0400	SPX 800 5	FR13	2 x CHK0400
SPX 900 4		3 x CHK0520	SPX 900 5		2 x CHK0400
SPX H10 4		3 x CHK0520	SPX H10 5		2 x CHK0400
SPX H12 4	FR14	4 x CHK0520	SPX H13 5	FR14	4 x CHK0400
SPX H16 4		6 x CHK0400	SPX H15 5		6 x CHK0400

CHK0520

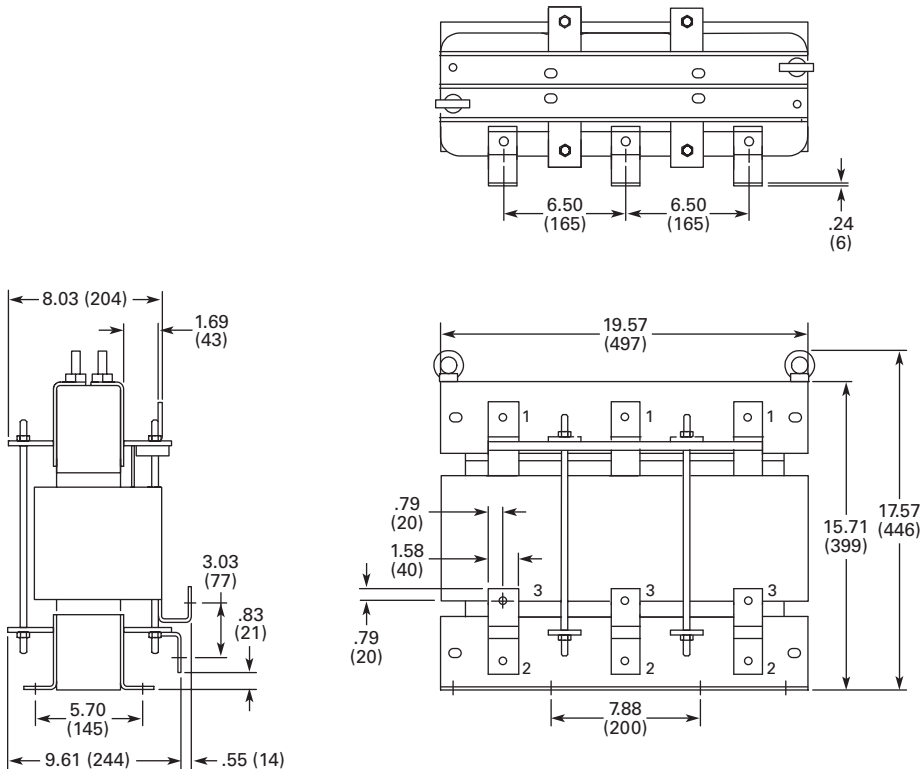

Note

① Chokes are provided with all FR10–FR14 drives.

Approximate Dimensions in Inches (mm)

CHK0400

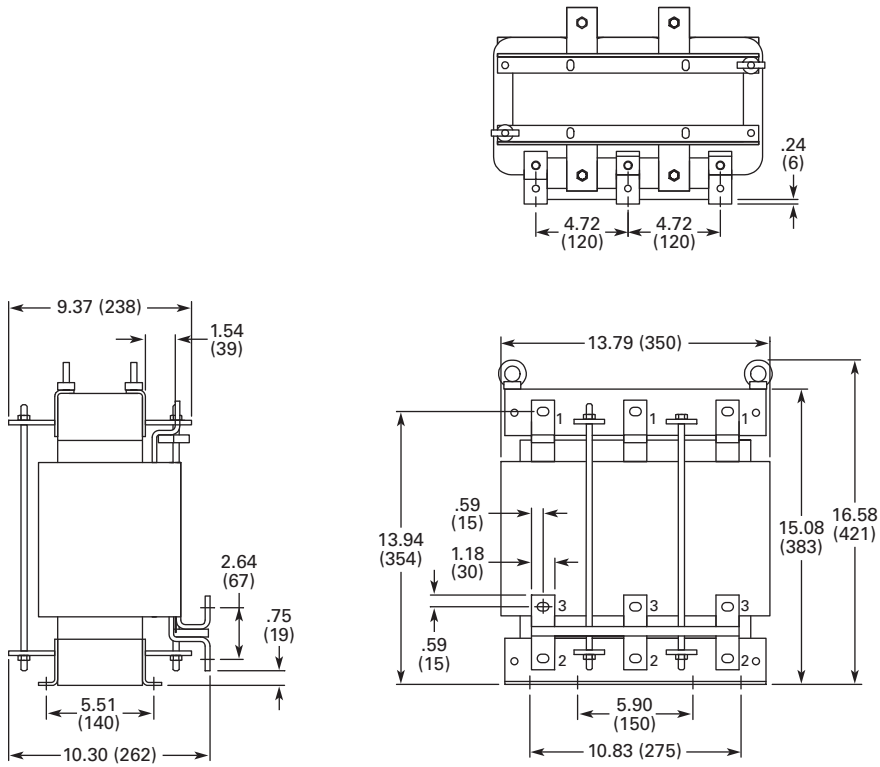

CHK0261

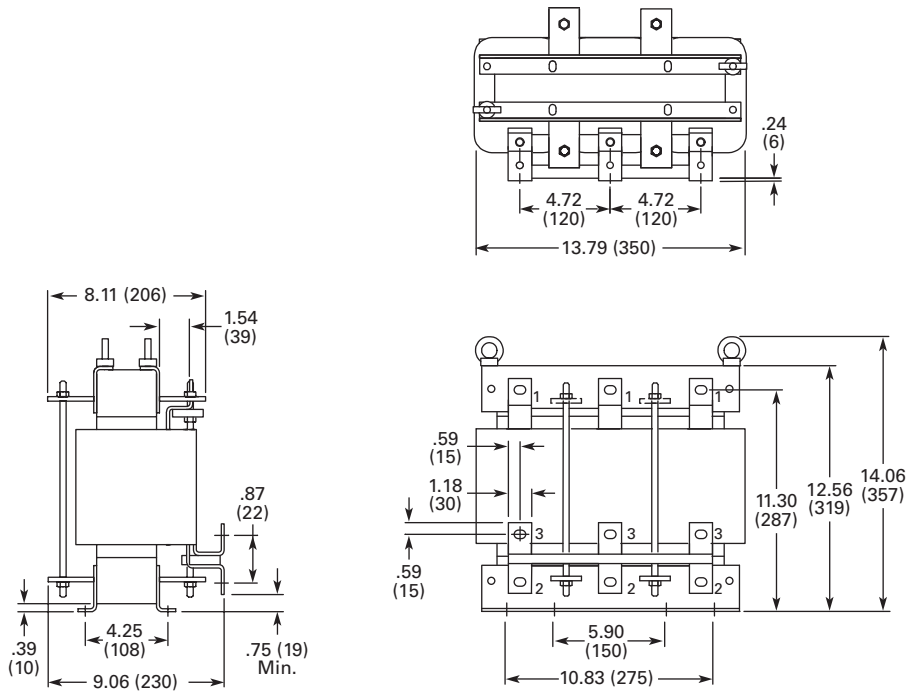

Enclosed Passive Filtered Drives

2



Enclosed Passive Filtered Drives

Product Description

The enclosed passive filtered clean power drives from Eaton’s Electrical Sector use tuned passive filters to significantly reduce line harmonics at the drive input terminals.

The enclosed passive filtered drive also delivers True Power Factor—in addition to reducing harmonic distortion, the enclosed passive filtered drive prevents transformer overheating and overloading of breakers and feeders, which enables the application of adjustable frequency drives on generators and other high impedance power systems.

The 9000X family of drives includes HVX9000, SVX9000, SLX9000, and SPX9000. 9000X Series drive ratings are rated for either high overload (I_H) or low overload (I_L). I_L indicates 110% overload capacity for 1 minute out of 10 minutes. I_H indicates 150% overload capacity for 1 minute out of 10 minutes.

Contents

<i>Description</i>	<i>Page</i>
Enclosed Passive Filtered Drives	
Application Description	V6-T2-201
Features and Benefits	V6-T2-207
Standards and Certifications	V6-T2-207
Product Identification	V6-T2-207
Catalog Number Selection	V6-T2-208
Product Selection	V6-T2-209
Options	V6-T2-216
Technical Data and Specifications	V6-T2-221
Wiring Diagram	V6-T2-223
Dimensions	V6-T2-224
Enclosed 18-Pulse Drives	V6-T2-233

Enclosed Passive Filtered Drive Products

- **Standard Enclosed**—covers a wide range of the most commonly ordered options. Pre-engineering eliminates the lead time normally associated with customer specific options. Available configurations are listed on **Pages V6-T2-207 to V6-T2-222**.
- **Modified Standard Enclosed**—applies to specific customer requirements that vary from the Standard Enclosed offering, such as the need for an additional indicating light or minor modifications to drawings. *Contact your local sales office for assistance in pricing and lead time.*
- **Custom Engineered**—for those applications with more unique or complex requirements, these are individually engineered to the customer’s needs. *Contact your local sales office for assistance in pricing and lead time.*

Application Description

Designed to meet the IEEE® 519-1992 requirements for harmonic distortion, the enclosed passive filtered

drive is an excellent choice for small and midsize drives applications where harmonics are a concern.

What Are Harmonics?

Take a perfect wave with a fundamental frequency of 60 Hz, which is close to what is supplied by the power company.

Perfect Wave

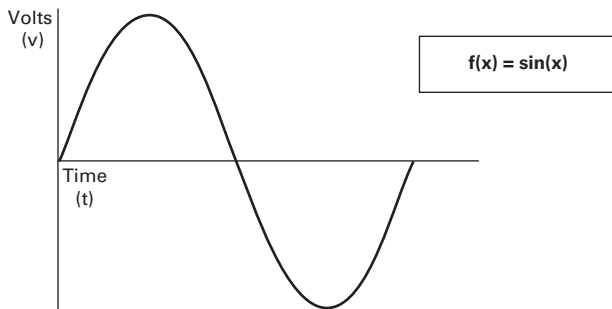

Add a second wave that is five times the fundamental frequency—300 Hz (typical of frequency added to the line by a fluorescent light).

Second Wave

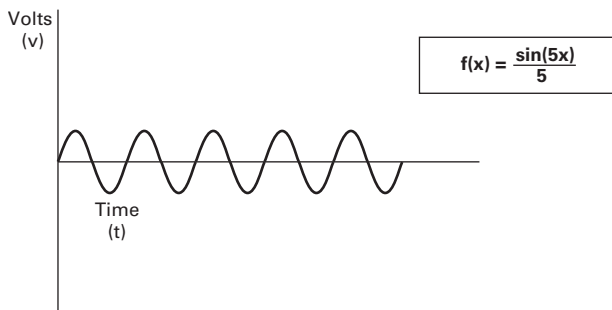

Combine the two waves. The result is a 60 Hz supply rich in fifth harmonics.

Resulting Supply

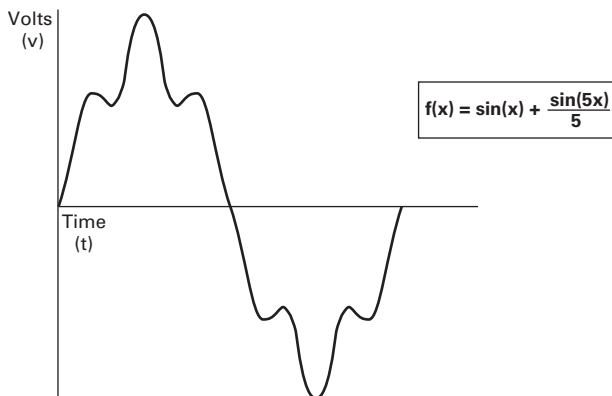

What Causes Harmonics?

Harmonics are the result of nonlinear loads that convert AC line voltage to DC. Examples of equipment that are non-linear loads are listed below:

- AC variable frequency drives
- DC drives
- Fluorescence lighting, computers, UPS systems
- Industrial washing machines, punch presses, welders, etc.

How Can Harmonics Due to VFDs Be Diminished?

By applying drives from the Eaton Clean Power Drives Family; The HCX9000, enclosed passive filtered drive and enclosed 18-pulse drive.

What Are Linear Loads?

Linear loads are primarily devices that run across the line and do not add harmonics. Motors are prime examples. The downside to having large motor linear loads is that they draw more energy than a VFD, because of their inability to control motor speed. In most applications there is a turn down valve used with the motor which will reduce the flow of the material, without significantly reducing the load to the motor. While this provides some measure of speed control, it is extremely inefficient.

Why Be Concerned About Harmonics?

1. **Installation and utility costs increase.** Harmonics cause damage to transformers and lower efficiencies due to the IR loss. These losses can become significant (from 16.6–21.6%) which can have a dramatic effect on the HVAC systems that are controlling the temperatures of the building where the transformer and drive equipment reside.
2. **Downtime and loss of productivity.** Telephones and data transmissions links may not be guaranteed to work on the same power grids polluted with harmonics.
3. **Downtime and nuisance trips of drives and other equipment.** Emergency generators have up to three times the impedance that is found in a conventional utility source. Thus the harmonic voltage can be up to three times as large, causing risk of operation problems.
4. **Larger motors must be used.** Motors running across the line that are connected on polluted power distribution grids can overheat or operate at lower efficiency due to harmonics.
5. **Higher installation costs.** Transformers and power equipment must be oversized to accommodate the loss of efficiencies. This is due to the harmonic currents circulating through the distribution without performing useful work.

2.8

Adjustable Frequency Drives

Low Harmonic Drives

2

How Does a VFD Convert Three-Phase AC to a Variable Output Voltage and Frequency?

The six-pulse VFD: The majority of all conventional drives that are built consist of a six-pulse configuration. The figure below represents a six-diode rectifier design that converts three-phase utility power to DC. The inverter section uses IGBTs to convert DC power to a simulated AC sine wave that can vary in frequency from 0–400 Hz.

The six-pulse VFD drive creates harmonic current distortion. The harmonic current that is created is energy that can not be used by customers and causes external heat and losses to all components including other drives that are on the same power distribution. The figure is a 100 hp drive with 45A of damaging harmonic current.

100 hp Six-Diode Rectifier Design

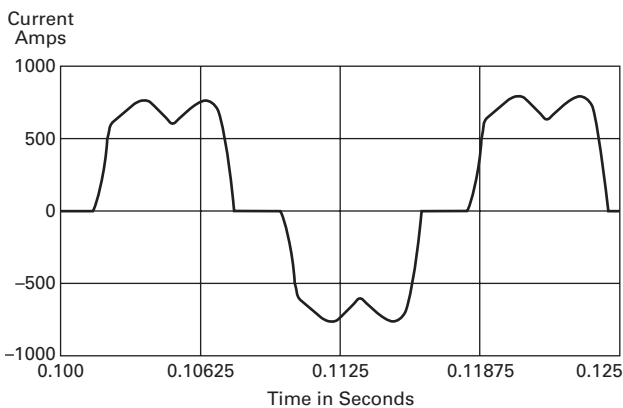

100 hp Six-Pulse Nonproductive Harmonic Current

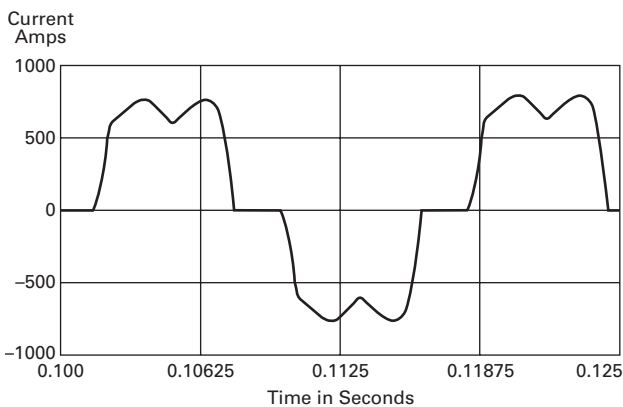

Six-Pulse Nonproductive Harmonic Current

Six-Pulse Circuit

Current harmonics		
$I_1 = 100\%$	$I_{11} = 6.10\%$	$I_{19} = 1.77\%$
$I_5 = 22.5\%$	$I_{13} = 4.06\%$	$I_{23} = 1.12\%$
$I_7 = 9.38\%$	$I_{17} = 2.26\%$	$I_{25} = 0.86\%$
Power = 100 hp		
Harmonic current = 45 amps		

Guidelines of Meeting IEEE Std. 519-1992 Harmonic Distortion Limits

The IEEE 519-1992 Specification is a standard that provides guidelines for commercial and industrial

users that are implementing medium and low voltage equipment.

Maximum Harmonic Current Distortion in % of the Fundamental (120V through 69,000V)

Isc/I _L	Harmonic Order (Odd Harmonics)					TDD
	h<11	11≤h<17	17≤h<23	23≤h<35	35≤h	
<20	4.0	2.0	1.5	0.6	0.3	5.0
20<50	7.0	3.5	2.5	1.0	0.5	8.0
50<100	10.0	4.5	4.0	1.5	0.7	12.0
100<1000	12.0	5.5	5.0	2.0	1.0	15.0
>1000	15.0	7.0	6.0	2.5	1.4	20.0

The ratio I_{sc}/I_L is the ratio of the short-circuit current available at the point of common coupling (PCC), to the maximum fundamental load current. Consequently, as the size of the user load decreases with respect to the size of the system, the percentage of harmonic current that the user is allowed to inject into the utility system increases.

Notes

TDD = Total demand distortion is the harmonic current distortion in percent of the maximum demand load current (15 or 30 minute demand).

I_{sc} = Maximum short-circuit current at the PCC not counting motor contribution.

I_L = Maximum demand load current for all of the connected loads (fundamental frequency component) at the PCC. All of the limits are measured at a point of common coupling.

One-Line Diagram for Harmonic Analysis

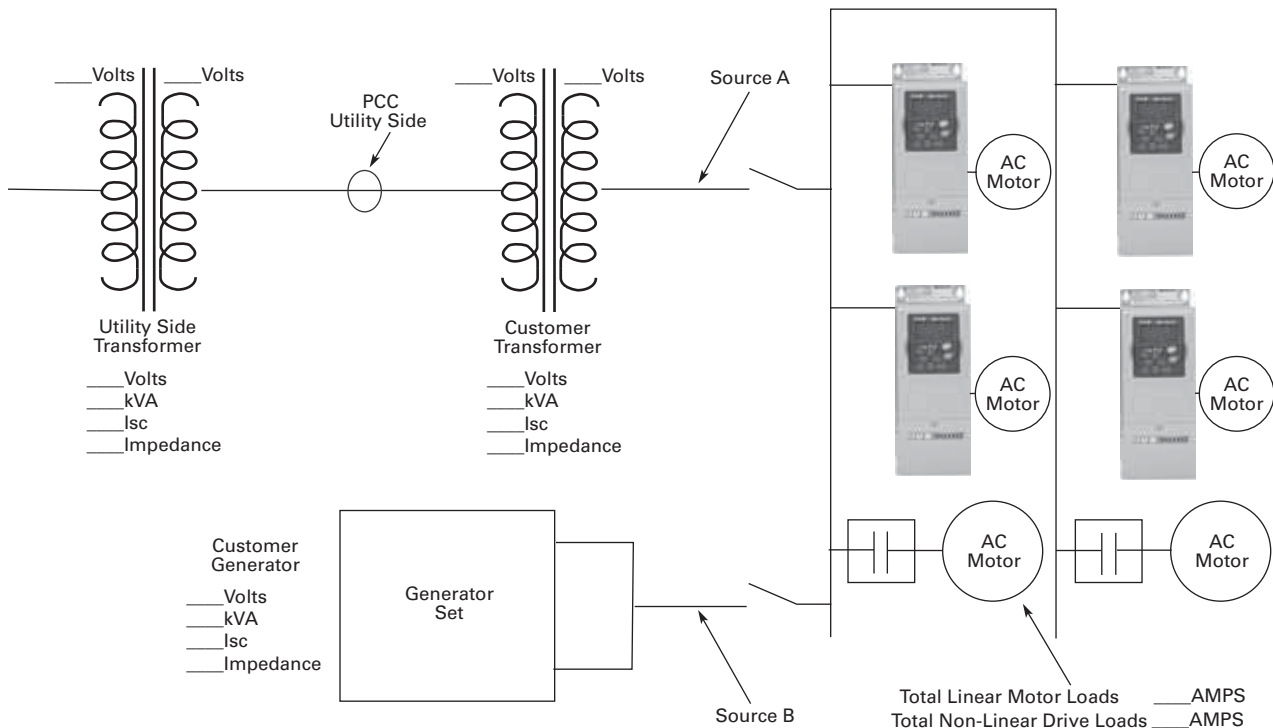

The best way to estimate AFD harmonic contribution to an electrical system is to perform a harmonic analysis based on known system characteristics. The one line in this figure would provide the data to complete the calculations.

Terms

- PCC (Point of Common Coupling) is defined as the electrical connecting point between the utility and multiple customers per the specifications in IEEE 519
- POA (Point of Analysis) is defined as where the harmonic calculations are taken

An oscilloscope can make all measurements at the PCC or POA to do an on-site harmonic evaluation.

Harmonic Reduction Methods to Meet IEEE 519**1. Line Reactor**

A line reactor is a three-phase series inductance on the line side of an AFD. If a line reactor is applied on all AFDs, it is possible to meet IEEE guidelines where 10–25% of system loads are AFDs, depending on the stiffness of the line and the value of line reactance. Line reactors are available in various values of percent impedance, most typically 1–1.5%, 3% and 5%.

Note: The 9000X drives come standard with a nominal 3% input impedance.

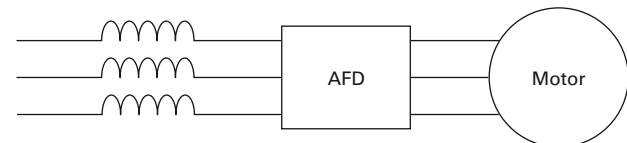
Line Reactor**Advantages**

- Low cost
- Can provide moderate reduction in voltage and current harmonics
- Available in various values of percent impedance
- Provides increased input protection for AFD and its semiconductors from line transients

Disadvantages

- May not reduce harmonic levels to below IEEE 519-1992 guidelines
- Voltage drop due to IR loss

2.8

Adjustable Frequency Drives

Low Harmonic Drives

2

2. Passive Filters

Tuned harmonic filters involve the series connection of an inductor with the shunt connection of an inductor and capacitor to form a low impedance path to ground for

a specific range of frequencies. This path presents an alternative to the flow of harmonic currents back into the utility source.

Enclosed Drive with Integrated Passive Filter

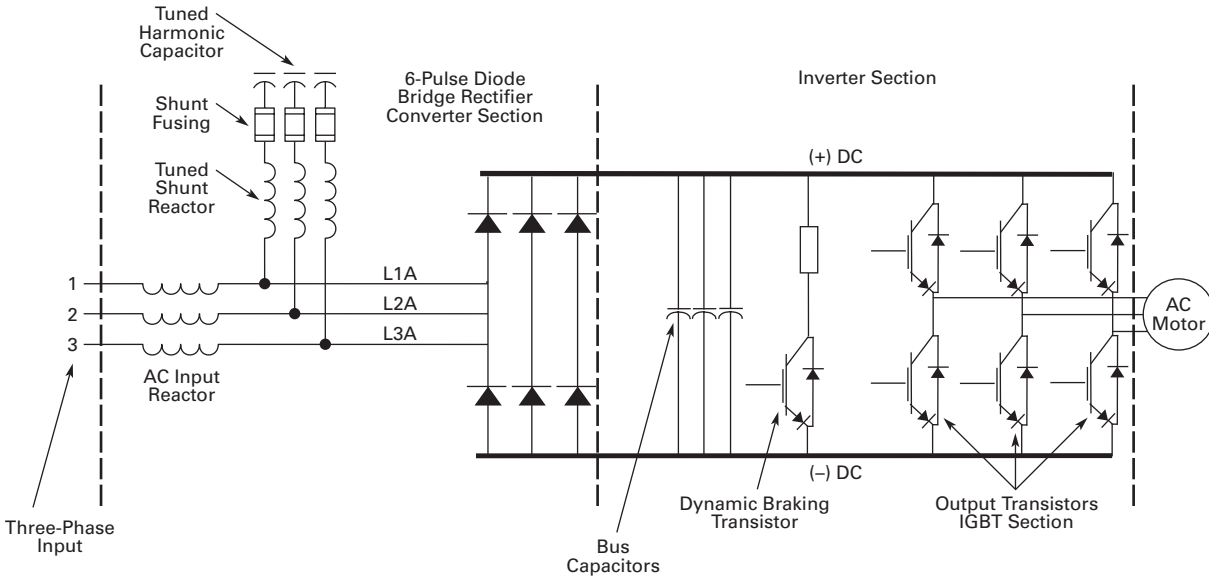

100 hp Enclosed 480V Drive with Integrated Passive Filter

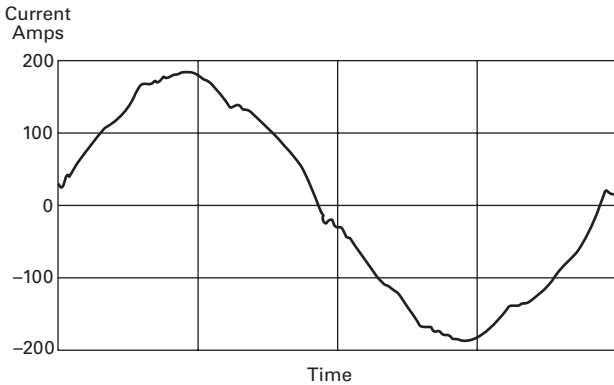

100 hp Enclosed 480V Drive with Integrated Passive Filter

Passive Filter

Current harmonics

$I_1 = 100\%$	$I_{11} = 0.24\%$	$I_{19} = 0.50\%$
$I_5 = 3.76\%$	$I_{13} = 1.1\%$	$I_{23} = 0.55\%$
$I_7 = 1.65\%$	$I_{17} = 0.80\%$	$I_{25} = 0.80\%$

Power = 100 hp

$H_c = 8.6$ Amps

Advantages

- Low cost for smaller horsepower applications
- More effective harmonic attenuation than 12-pulse drives
- Provides increased input protection for AFD from line transients

Disadvantages

- Capacitors age over time, unlike magnetics
- Not as effective as 18-pulse drives
- Challenging to retrofit with bypass applications

3. 12-Pulse Converters

A 12-pulse converter incorporates two separate AFD input semiconductor bridges, which are fed from 30° phase shifted power sources with identical impedance. The sources may be two isolation transformers, where one is a delta/wye design (which provides the phase shift) and

the second a delta/delta design (which does not phase shift). The 12-pulse arrangement allows the harmonics from the first converter to cancel the harmonics of the second. Up to approximately 85% reduction of harmonic current and voltage distortion may be achieved (over standard

six-pulse converter). This permits a facility to use a larger percentage of AFD loads under IEEE 519-1992 guidelines than allowable using line reactors or DC chokes. A harmonic analysis is required to guarantee compliance with guidelines.

Basic 12-Pulse Rectifier with "Phase Shifting" Transformer

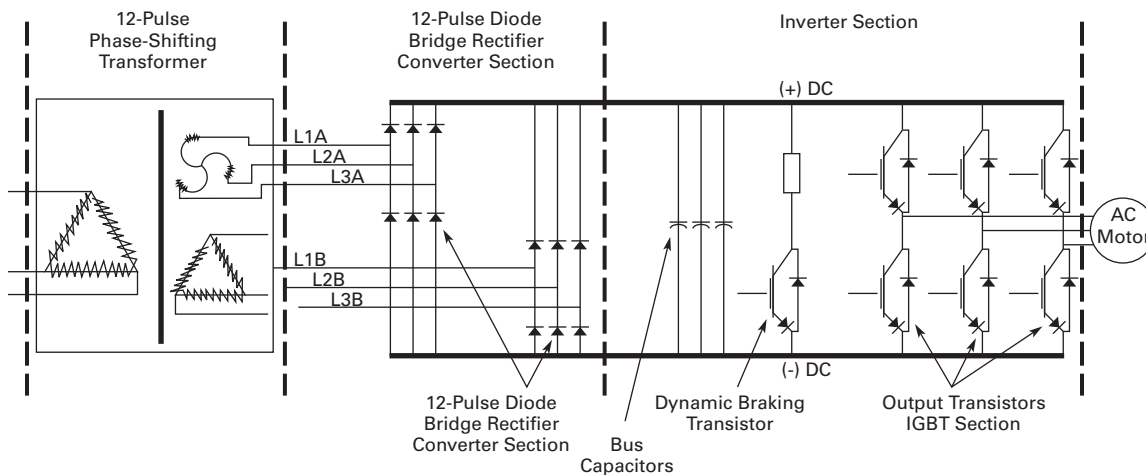

100 hp 480V Drive with 12-Pulse Rectifier

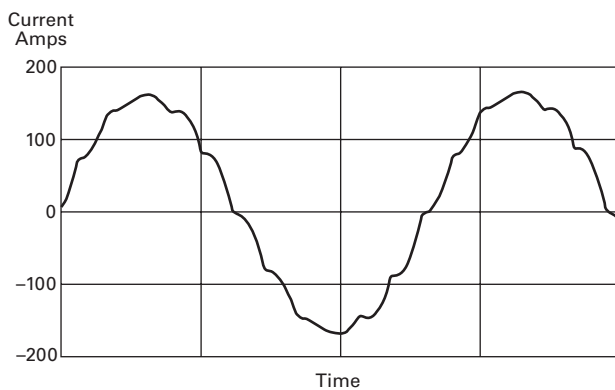

100 hp 480V Drive with 12-Pulse Rectifier

12-Pulse Circuit

Current harmonics

$I_1 = 100\%$	$I_{11} = 4.19\%$	$I_{19} = 0.06\%$
$I_5 = 1.25\%$	$I_{13} = 2.95\%$	$I_{23} = 0.87\%$
$I_7 = 0.48\%$	$I_{17} = 0.21\%$	$I_{25} = 0.73\%$

Power = 100 hp

$H_c = 20$ Amps

Advantages

- Reasonable cost, although significantly more than reactors or chokes
- Substantial reduction (up to approx. 85%) in voltage and current harmonics
- Provides increased input protection for AFD and its semiconductors from line transients

Disadvantages

- Impedance matching of phase shifted sources is critical to performance
- Transformers often require separate mounting or larger AFD enclosures
- May not reduce distribution harmonic levels to below IEEE 519-1992 guidelines
- Cannot retrofit for most AFDs

4. Clean Power Drives

When the total load is comprised of non-linear load such as drives, and the ratio is I_{SC}/I_L , the greatest harmonic mitigation is required. Under these conditions, the currents drawn from the supply need to be sinusoidal and “clean” such that system interference and additional

losses are negligible. Eaton’s Enclosed 18-Pulse clean power drive uses a phase-shifting auto-transformer with delta-connected winding that carries only the ampere-turns caused by the difference in load currents. This results in nine separate phases. In this type of configuration, the

total kVA rating of the transformer magnetic system was only 48% that of the motor load. A traditional isolated transformer system, with multipulse windings, would require the full kVA rating to be supported, which is more common in an MV step-down transformer.

The integrated 18-pulse clean power drive, with near sine wave input current and low harmonics will meet the requirements of IEEE 519-1992 under all practical operating conditions. The comparisons with six-pulse passive filter and 12-pulse systems are shown on **Pages V6-T2-202, V6-T2-204** and below.

Basic 18-Pulse Rectifier with Phase-Shifting Auto-Transformer

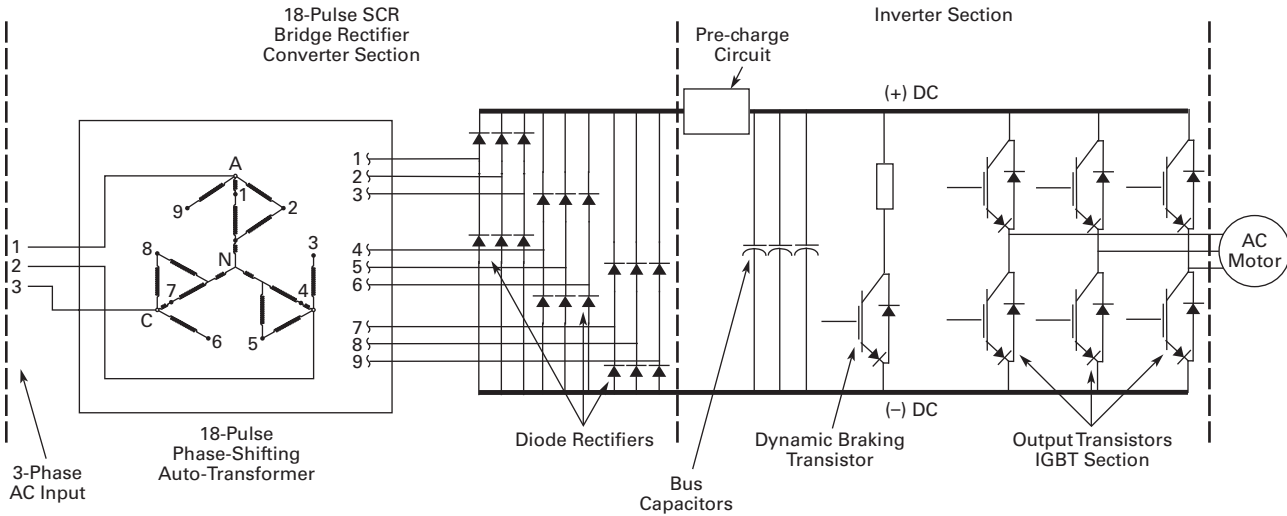

100 hp 480V Drive with 18-Pulse Rectifiers

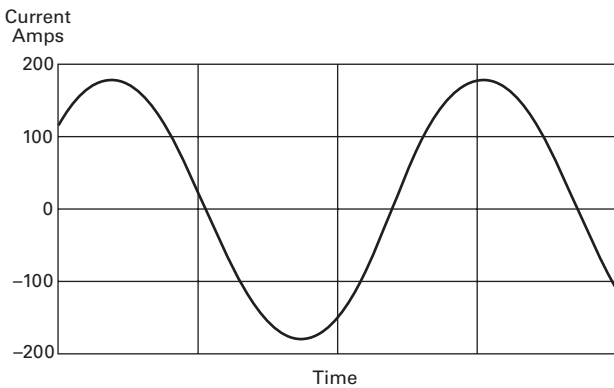

100 hp 480V Drive with 18-Pulse Rectifiers

18-Pulse Clean Power

Current harmonics

$I_1 = 100\%$	$I_{11} = 0.24\%$	$I_{19} = 1.00\%$
$I_5 = 0.16\%$	$I_{13} = 0.10\%$	$I_{23} = 0.01\%$
$I_7 = 0.03\%$	$I_{17} = 0.86\%$	$I_{25} = 0.01\%$

Power = 100 hp

$H_c = 5.9$ Amps

Advantages

- Effectively guarantees compliance with IEEE 519-1992
- Provides increased input protection for AFD and its semiconductors from line transients
- Up to 4 times the harmonic reduction of 12-pulse methods
- Smaller transformer than isolation transformer used in 12-pulse converter
- Minimizes ripple current in capacitors, doubling expected capacitor life

Disadvantages

- Not as cost effective as some other methods at small (<50) horsepower

Features and Benefits

New enclosed passive filtered clean power drive features include (at 480V):

- UL Type 1, UL Type 12, UL Type 3R and NEMA 12 with gaskets and filters
- Input voltage: 480V, 230V, 575V
- Complete range of control, network and power options

- Horsepower range:
 - 480V, 7-1/2–400 hp I_L
 - 230V, 7-1/2–100 hp I_L; consult factory for details
 - 575V, 15–400 hp I_L; consult factory for details

- Single enclosure for both drive and filter reduces field wiring and enables convenient bypass installation
- Packaged solution ensures optimal coordination of drive and filter

Standards and Certifications

- UL
- cUL
- 508C

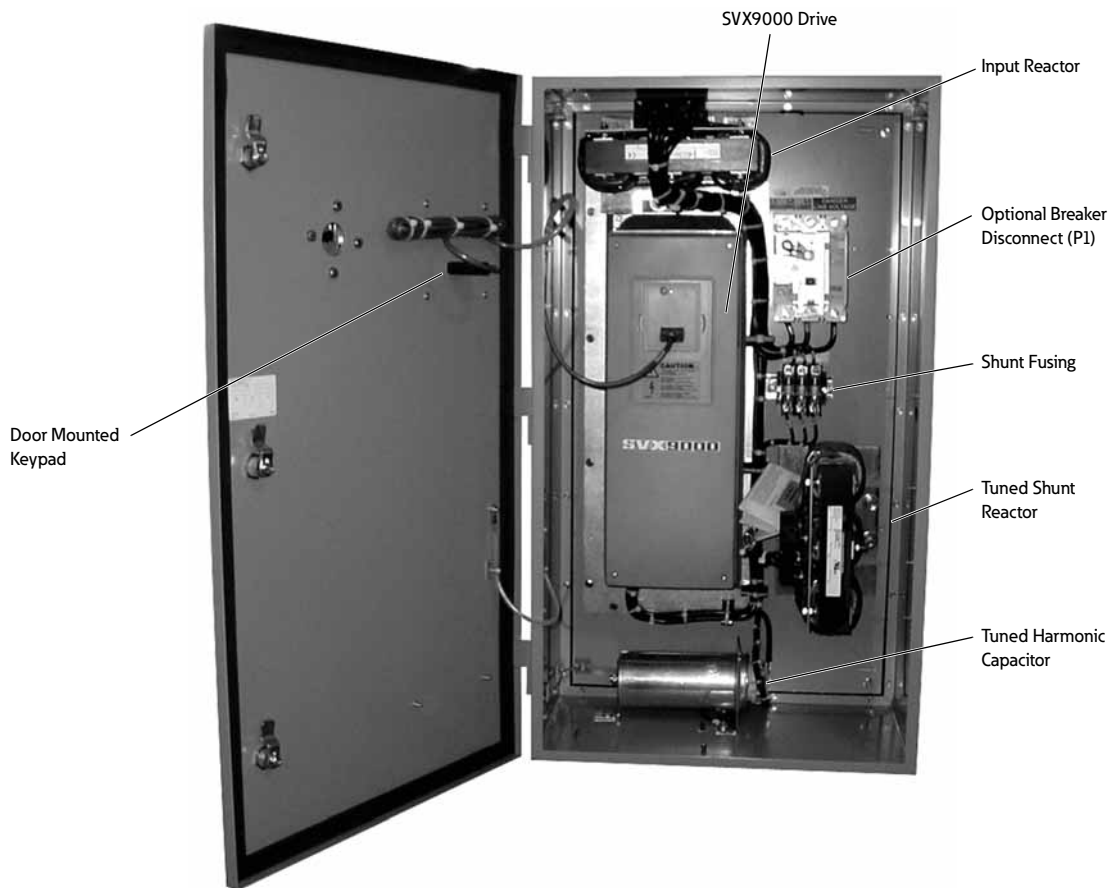
**Product Identification****Enclosed Passive Filtered Drive—UL Type 12, 40 hp**

Catalog Number Selection

Enclosed Passive Filtered Drives

2

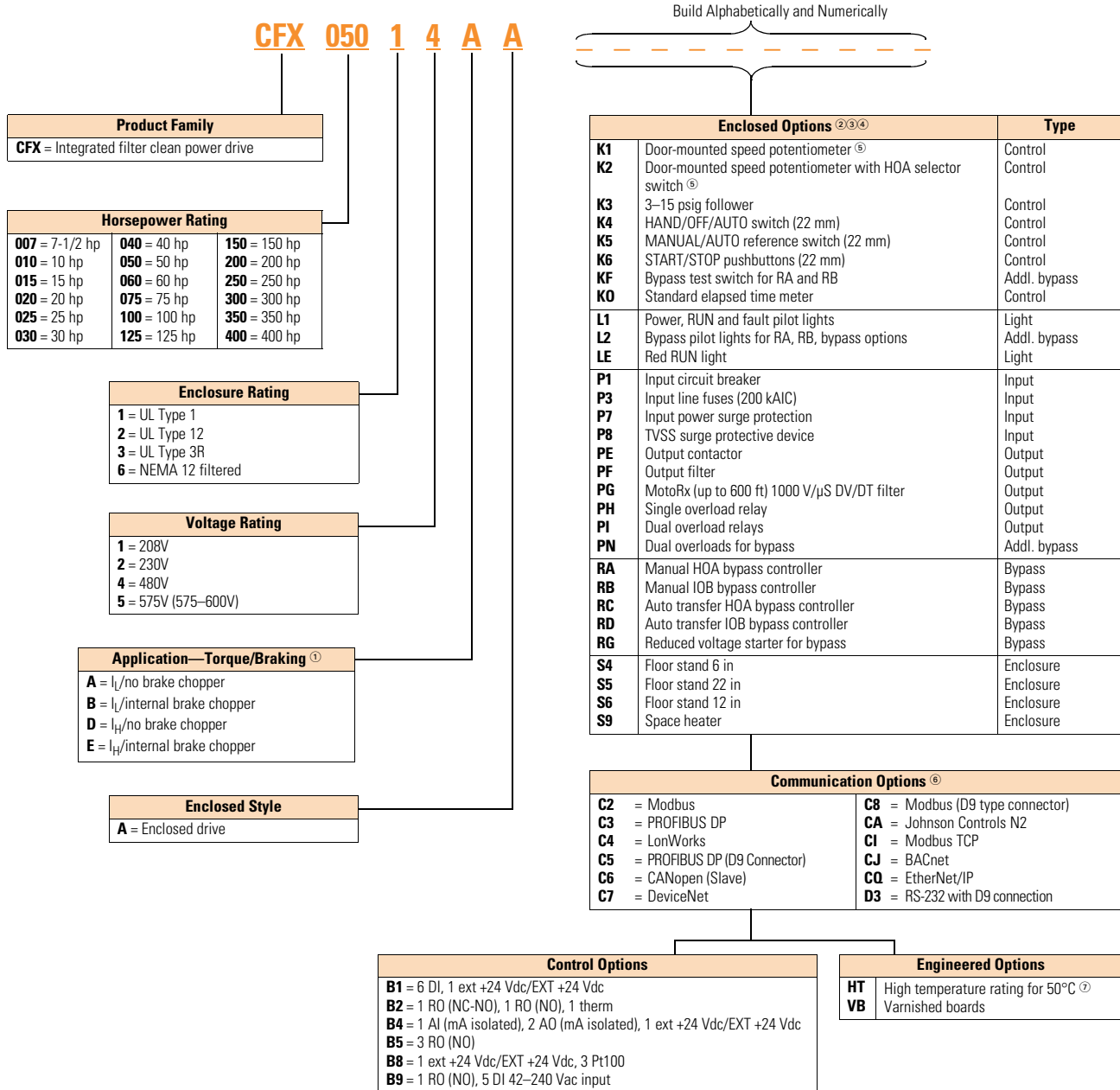

Notes

- ① Brake chopper is standard in 208V, 230V and 480V drives up to FR6; optional in all other drives.
- ② Local/remote keypad is included as the standard control panel.
- ③ Some options are voltage and/or horsepower specific. Consult your Eaton representative for details.
- ④ See **Pages V6-T2-218** and **V6-T2-219** for complete descriptions.
- ⑤ Includes local/remote speed reference switch.
- ⑥ See **Pages V6-T2-216** and **V6-T2-217** for complete descriptions.
- ⑦ Consult Eaton for availability.

Product Selection

When Ordering

- Select a base catalog number that meets the application requirements—nominal horsepower, voltage and enclosure rating. (The enclosed drive's continuous output amp rating should be equal to or greater than the motor's full load amp rating.) The base enclosed package includes a standard drive, door-mounted alphanumeric panel and enclosure.
- The enclosed passive filtered drive product uses the term High Overload (I_H) in place of the term Constant Torque (CT). Likewise, Low Overload (I_L) is used in place of the term Variable Torque (VT). The new terms are a more precise description of the rating. The older terms included ambient temperature ratings in addition to overload ratings. In order to minimize enclosure size and offer the highest ambient temperature rating, overload and temperature ratings are now treated separately. Ambient temperature ratings are shown in the following table.

Ambient Temperature Ratings

Enclosure Size	I_H	I_L
B, C, 9 ①	40°C	40°C
7, 8	50°C	50°C

- If dynamic brake chopper or control/communication option is desired, change the appropriate code in the base catalog number.
- All of the programming is exactly the same as the standard SVX9000 drive.
- Select enclosed options. Add the codes as suffixes to the base catalog number in alphabetical and numeric order.

Note

- ① For high temperature rating, select HT option code and contact factory.

208V Drives

2

Enclosed Passive Filtered Drive



UL Type 1, UL Type 12, UL Type 3R and NEMA 12 Filtered

hp	NEC Current (A)	Chassis Frame	UL Type 1 Base Catalog Number	UL Type 12 and NEMA 12 Filtered Base Catalog Number	UL Type 3R Base Catalog Number
Low Overload Drive					
7-1/2	24.2	FR5	①	CFX00721BA	CFX00731BA
10	30.8	FR5	①	CFX01021BA	CFX01031BA
15	46.2	FR6	①	CFX01521BA	CFX01531BA
20	59.4	FR6	①	CFX02021BA	CFX02031BA
25	74.8	FR7	①	CFX02521AA	CFX02531AA
30	88	FR7	①	CFX03021AA	CFX03031AA
40	114	FR7	①	CFX04021AA	CFX04031AA
50	143	FR8	CFX05011AA	CFX05061AA	CFX05031AA
60	169	FR8	CFX06011AA	CFX06061AA	CFX06031AA
75	211	FR8	CFX07511AA	CFX07561AA	CFX07531AA
100	273	FR9	CFX10011AA	CFX10061AA	CFX10031AA
High Overload Drive					
7-1/2	24.2	FR5	①	CFX00721EA	CFX00731EA
10	30.8	FR6	①	CFX01021EA	CFX01031EA
15	46.2	FR6	①	CFX01521EA	CFX01531EA
20	59.4	FR7	①	CFX02021DA	CFX02031DA
25	74.8	FR7	①	CFX02521DA	CFX02531DA
30	88	FR7	①	CFX03021DA	CFX03031DA
40	114	FR8	CFX04011DA	CFX04061DA	CFX04031DA
50	143	FR8	CFX05011DA	CFX05061DA	CFX05031DA
60	169	FR8	CFX06011DA	CFX06061DA	CFX06031DA
75	211	FR9	CFX07511DA	CFX07561DA	CFX07531DA
100	273	FR9	CFX10011DA	CFX10061DA	CFX10031DA

Enclosed Passive Filtered Drive Enclosure

Chassis Frame	UL Type 1		UL Type 12		UL Type 3R	
	Disconnect Only	With Power Options	Disconnect Only	With Power Options	Disconnect Only	With Power Options
FR4	N/A	N/A	B	C	B	C
FR5	N/A	N/A	B	C	B	C
FR6	N/A	N/A	B	C	B	C
FR7	N/A	7	C	7	C	D
FR8	7	7	7	7	F	F
FR9	8	8	8	8	F	F

Enclosure Dimension Drawings

Enclosure Size	UL Type 1 and UL Type 12	UL Type 3R
B	See Page V6-T2-224	See Page V6-T2-226
C	See Page V6-T2-225	See Page V6-T2-227
D	N/A	See Page V6-T2-228
F	N/A	See Page V6-T2-229
7 ^②	See Page V6-T2-230	③
8 ^②	See Page V6-T2-231	③
9	See Page V6-T2-232	③

Notes

- ① FR5–FR7 drives not available in UL Type 1.
- ② Enclosures 7 and 8 are NEMA 12 filtered.
- ③ Not available for UL Type 3R.

230V Drives

Enclosed Passive Filtered Drive



UL Type 1, UL Type 12, UL Type 3R and NEMA 12 Filtered

hp	NEC Current (A)	Chassis Frame	UL Type 1 Base Catalog Number	UL Type 12 and NEMA 12 Filtered Base Catalog Number	UL Type 3R Base Catalog Number
Low Overload Drive					
7-1/2	22	FR5	①	CFX00722BA	CFX00732BA
10	28	FR5	①	CFX01022BA	CFX01032BA
15	42	FR6	①	CFX01522BA	CFX01532BA
20	54	FR6	①	CFX02022BA	CFX02032BA
25	68	FR7	①	CFX02522AA	CFX02532AA
30	80	FR7	①	CFX03022AA	CFX03032AA
40	104	FR7	①	CFX04022AA	CFX04032AA
50	130	FR8	CFX05012AA	CFX05062AA	CFX05032AA
60	154	FR8	CFX06012AA	CFX06062AA	CFX06032AA
75	192	FR8	CFX07512AA	CFX07562AA	CFX07532AA
100	248	FR9	CFX10012AA	CFX10062AA	CFX10032AA
High Overload Drive					
7-1/2	22	FR5	①	CFX00722EA	CFX00732EA
10	28	FR6	①	CFX01022EA	CFX01032EA
15	42	FR6	①	CFX01522EA	CFX01532EA
20	54	FR7	①	CFX02022DA	CFX02032DA
25	68	FR7	①	CFX02522DA	CFX02532DA
30	80	FR7	①	CFX03022DA	CFX03032DA
40	104	FR8	CFX04012DA	CFX04062DA	CFX04032DA
50	130	FR8	CFX05012DA	CFX05062DA	CFX05032DA
60	154	FR8	CFX06012DA	CFX06062DA	CFX06032DA
75	192	FR9	CFX07512DA	CFX07562DA	CFX07532DA
100	248	FR9	CFX10012DA	CFX10062DA	CFX10032DA

Enclosed Passive Filtered Drive Enclosure

Chassis Frame	UL Type 1		UL Type 12		UL Type 3R	
	Disconnect Only	With Power Options	Disconnect Only	With Power Options	Disconnect Only	With Power Options
FR4	N/A	N/A	B	C	B	C
FR5	N/A	N/A	B	C	B	C
FR6	N/A	N/A	B	C	B	C
FR7	N/A	7	C	7	C	D
FR8	7	7	7	7	F	F
FR9	8	8	8	8	F	F

Enclosure Dimension Drawings

Enclosure Size	UL Type 1 and UL Type 12	UL Type 3R
B	See Page V6-T2-224	See Page V6-T2-226
C	See Page V6-T2-225	See Page V6-T2-227
D	N/A	See Page V6-T2-228
F	N/A	See Page V6-T2-229
7 ②	See Page V6-T2-230	③
8 ②	See Page V6-T2-231	③
9	See Page V6-T2-232	③

Notes

- ① FR5–FR7 drives not available in UL Type 1.
- ② Enclosures 7 and 8 are NEMA 12 filtered.
- ③ Not available for UL Type 3R.

480V Drives

2

Enclosed Passive Filtered Drive



Enclosed Passive Filtered Base Drive

hp	NEC Current (A)	Chassis Frame	UL Type 1 Base Catalog Number ①	UL Type 12 and NEMA 12 Filtered Base Catalog Number ①	UL Type 3R Base Catalog Number ①
Low Overload Drive					
7-1/2	11	FR4	②	CFX00724BA	CFX00734BA
10	14	FR5	②	CFX01024BA	CFX01034BA
15	21	FR5	②	CFX01524BA	CFX01534BA
20	27	FR5	②	CFX02024BA	CFX02034BA
25	34	FR6	②	CFX02524BA	CFX02534BA
30	40	FR6	②	CFX03024BA	CFX03034BA
40	52	FR6	②	CFX04024BA	CFX04034BA
50	65	FR7	CFX05014AA ③	CFX05024AA	CFX05034AA
60	77	FR7	CFX06014AA ③	CFX06024AA	CFX06034AA
75	96	FR7	CFX07514AA ③	CFX07524AA	CFX07534AA
100	124	FR8	CFX10014AA	CFX10064AA	CFX10034AA
125	156	FR8	CFX12514AA	CFX12564AA	CFX12534AA
150	180	FR8	CFX15014AA	CFX15064AA	CFX15034AA
200	240	FR9	CFX20014AA	CFX20064AA	CFX20034AA
250	302	FR9	CFX25014AA	CFX25064AA	CFX25034AA
300	361	FR10	CFX30014AA	CFX30064AA	④
350	414	FR10	CFX35014AA	CFX35064AA	④
400	477	FR10	CFX40014AA	CFX40064AA	④
High Overload Drive					
7-1/2	11	FR5	②	CFX00724EA	CFX00734EA
10	14	FR5	②	CFX01024EA	CFX01034EA
15	21	FR5	②	CFX01524EA	CFX01534EA
20	27	FR6	②	CFX02024EA	CFX02034EA
25	34	FR6	②	CFX02524EA	CFX02534EA
30	40	FR6	②	CFX03024EA	CFX03034EA
40	52	FR7	CFX04014DA ③	CFX04024DA	CFX04034DA
50	65	FR7	CFX05014DA ③	CFX05024DA	CFX05034DA
60	77	FR7	CFX06014DA ③	CFX06024DA	CFX06034DA
75	96	FR8	CFX07514DA	CFX07564DA	CFX07534DA
100	124	FR8	CFX10014DA	CFX10064DA	CFX10034DA
125	156	FR8	CFX12514DA	CFX12564DA	CFX12534DA
150	180	FR9	CFX15014DA	CFX15064DA	CFX15034DA
200	240	FR9	CFX20014DA	CFX20064DA	CFX20034DA
250	302	FR10	CFX25014DA	CFX25064DA	④
300	361	FR10	CFX30014DA	CFX30064DA	④
350	414	FR10	CFX35014DA	CFX35064DA	④

Notes

- ① The integrated filter clean power assembly includes a standard drive, door-mounted local/remote keypad and enclosure.
- ② FR4–FR6 drives not available in UL Type 1.
- ③ This catalog number is used only with power options.
- ④ Consult factory.

Enclosed Passive Filtered Drive Enclosure

Chassis Frame	UL Type 1		UL Type 12		UL Type 3R	
	Disconnect Only	With Power Options	Disconnect Only	With Power Options	Disconnect Only	With Power Options
FR4	N/A	N/A	B	C	B	C
FR5	N/A	N/A	B	C	B	C
FR6	N/A	N/A	B	C	B	C
FR7	N/A	7	C	7	C	D
FR8	7	7	7	7	F	F
FR9	8	8	8	8	F	F
FR10	9	9	9	9	①	①

2

Enclosure Dimension Drawings

Enclosure Size	UL Type 1 and UL Type 12	UL Type 3R
B	See Page V6-T2-224	See Page V6-T2-226
C	See Page V6-T2-225	See Page V6-T2-227
D	N/A	See Page V6-T2-228
F	N/A	See Page V6-T2-229
7 ②	See Page V6-T2-230	③
8 ②	See Page V6-T2-231	③
9	See Page V6-T2-232	③

Notes

- ① Consult factory.
- ② Enclosures 7 and 8 are NEMA 12 filtered.
- ③ Not available for UL Type 3R.

575V Drives

2

Enclosed Passive Filtered Drive



UL Type 1, UL Type 12, UL Type 3R and NEMA 12 Filtered

hp	NEC Current (A)	Chassis Frame	UL Type 1 Base Catalog Number	UL Type 12 and NEMA 12 Filtered Base Catalog Number	UL Type 3R Base Catalog Number
Low Overload Drive					
15	17	FR6	①	CFX01525AA	CFX01535AA
20	22	FR6	①	CFX02025AA	CFX02035AA
25	27	FR6	①	CFX02525AA	CFX02535AA
30	32	FR6	①	CFX03025AA	CFX03035AA
40	41	FR7	①	CFX04025AA	CFX04035AA
50	52	FR7	①	CFX05025AA	CFX05035AA
60	62	FR8	CFX06015AA	CFX06065AA	CFX06035AA
75	77	FR8	CFX07515AA	CFX07565AA	CFX07535AA
100	99	FR8	CFX10015AA	CFX10065AA	CFX10035AA
125	125	FR9	CFX12515AA	CFX12565AA	CFX12535AA
150	144	FR9	CFX15015AA	CFX15065AA	CFX15035AA
200	192	FR9	CFX20015AA	CFX20065AA	CFX20035AA
250	242	FR10	CFX25015AA	CFX25065AA	②
300	289	FR10	CFX30015AA	CFX30065AA	②
400	382	FR10	CFX40015AA	CFX40065AA	②
High Overload Drive					
10	14	FR6	①	CFX01025DA	CFX01035DA
15	17	FR6	①	CFX01525DA	CFX01535DA
20	22	FR6	①	CFX02025DA	CFX02035DA
25	27	FR6	①	CFX02525DA	CFX02535DA
30	32	FR7	①	CFX03025DA	CFX03035DA
40	41	FR7	①	CFX04025DA	CFX04035DA
50	52	FR8	CFX05015DA	CFX05065DA	CFX05035DA
60	62	FR8	CFX06015DA	CFX06065DA	CFX06035DA
75	77	FR8	CFX07515DA	CFX07565DA	CFX07535DA
100	99	FR9	CFX10015DA	CFX10065DA	CFX10035DA
125	125	FR9	CFX12515DA	CFX12565DA	CFX12535DA
150	144	FR9	CFX15015DA	CFX15065DA	CFX15035DA
200	192	FR10	CFX20015DA	CFX20065DA	②
250	242	FR10	CFX25015DA	CFX25065DA	②
300	289	FR10	CFX30015DA	CFX30065DA	②

Notes

- ① FR6–FR7 drives not available in UL Type 1.
- ② Consult factory.

Enclosed Passive Filtered Drive Enclosure

Chassis Frame	UL Type 1		UL Type 12		UL Type 3R	
	Disconnect Only	With Power Options	Disconnect Only	With Power Options	Disconnect Only	With Power Options
FR6	N/A	N/A	B	C	B	C
FR7	N/A	7	C	7	C	D
FR8	7	7	7	7	F	F
FR9	8	8	8	8	F	F
FR10	9	9	9	9	①	①

2

Enclosure Dimension Drawings

Enclosure Size	UL Type 1 and UL Type 12	UL Type 3R
B	See Page V6-T2-224	See Page V6-T2-226
C	See Page V6-T2-225	See Page V6-T2-227
D	N/A	See Page V6-T2-228
F	N/A	See Page V6-T2-229
7 ②	See Page V6-T2-230	③
8 ②	See Page V6-T2-231	③
9	See Page V6-T2-232	③

Notes

- ① Consult factory.
- ② Enclosures 7 and 8 are NEMA 12 filtered.
- ③ Not available for UL Type 3R.

Options

2

Enclosed Passive Filtered Drive Option Board Kits

The enclosed passive filtered drive series can accommodate a wide selection of expander and adapter option boards to customize the drive for your application needs. The drive's control unit is designed to accept a total of five option boards.

The enclosed passive filtered drive series factory-installed standard board configuration includes an A9 I/O board and an A2 relay output board, which are installed in slots A and B.

Option Boards

Option Board Kits

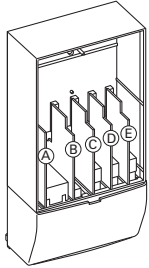

Option Kit Description ^①	Allowed Slot Locations ^②	Field Installed Catalog Number	Factory Installed Option Designator	SVX Ready Programs					
				Basic	Local/Remote	Standard	MSS	PID	Multi-P. PFC
Standard I/O Cards									
2 RO (NC/NO)	B	OPTA2	—	■	■	■	■	■	■
6 DI, 1 DO, 2 AI, 1AO, 1 +10 Vdc ref, 2 ext +24 Vdc/ext +24 Vdc	A	OPTA9	—	■	■	■	■	■	■
Extended I/O Cards									
6 DI	B, C, D , E	OPTB1	B1	—	—	—	—	—	■
1 RO (NC/NO), 1 RO (NO), 1 therm	B, C, D , E	OPTB2	B2	—	—	—	—	—	■
1 AI (mA isolated), 2 AO (mA isolated)	B, C, D , E	OPTB4	B4	■	■	■	■	■	■
3 RO (NO)	B, C, D , E	OPTB5	B5	—	—	—	—	—	■
3 Pt100 RTD board	B, C, D , E	OPTB8	B8	—	—	—	—	—	—
1 RO (NO), 5 DI 42–240 Vac input	B, C, D , E	OPTB9	B9	—	—	—	—	—	■
Communication Cards ^③									
Modbus	D, E	OPTC2	C2	■	■	■	■	■	■
Modbus TCP	D, E	OPTCI	CI	■	■	■	■	■	■
BACnet	D, E	OPTCJ	CJ	■	■	■	■	■	■
EtherNet/IP	D, E	OPTCQ	CQ	■	■	■	■	■	■
Johnson Controls N2	D, E	OPTC2	CA	■	■	■	■	■	■
PROFIBUS DP	D, E	OPTC3	C3	■	■	■	■	■	■
LonWorks	D, E	OPTC4	C4	■	■	■	■	■	■
PROFIBUS DP (D9 connector)	D, E	OPTC5	C5	■	■	■	■	■	■
CANopen (slave)	D, E	OPTC6	C6	■	■	■	■	■	■
DeviceNet	D, E	OPTC7	C7	■	■	■	■	■	■
Modbus (D9 type connector)	D, E	OPTC8	C8	■	■	■	■	■	■
RS-232 with D9 connection	D, E	OPTD3	D3	■	■	■	■	■	■

Notes

- ① AI = Analog Input; AO = Analog Output, DI = Digital Input, DO = Digital Output, RO = Relay Output
 ② Option card must be installed in one of the slots listed for that card. Slot indicated in bold is the preferred location.
 ③ OPTC2 is a multi-protocol option card.

Modbus RTU Network Communications

The Modbus Network Card OPTC2 is used for connecting the 9000X Drive as a slave on a Modbus network. The interface is connected by a 9-pin DSUB connector (female) and the baud rate ranges from 300 to 19,200 baud. Other communication parameters include an address range from 1 to 247; a parity of None, Odd or Even; and the stop bit is 1.

PROFIBUS Network Communications

The PROFIBUS Network Card OPTC3 is used for connecting the 9000X Drive as a slave on a PROFIBUS-DP network. The interface is connected by a 9-pin DSUB connector (female). The baud rates range from 9.6K baud to 12M baud, and the addresses range from 1 to 127.

LonWorks Network Communications

The LonWorks Network Card OPTC4 is used for connecting the 9000X Drive on a LonWorks network. This interface uses Standard Network Variable Types (SNVT) as data types. The channel connection is achieved using a FTT-10A Free Topology transceiver via a single twisted transfer cable. The communication speed with LonWorks is 78 kBits/s.

CANopen (Slave) Communications

The CANopen (Slave) Network Card OPTC6 is used for connecting the 9000X Drive to a host system. According to ISO® 11898 standard cables to be chosen for CAN bus should have a nominal impedance of 120 ohms, and specific line delay of nominal 5 as/m. 120 ohm line termination resistors required for installation.

DeviceNet Network Communications

The DeviceNet Network Card OPTC7 is used for connecting the 9000X Drive on a DeviceNet Network. It includes a 5.08 mm pluggable connector. Transfer method is via CAN using a two-wire twisted shielded cable with two-wire bus power cable and drain. The baud rates used for communication include 125K baud, 250K baud and 500K baud.

Johnson Controls Metasys N2 Network Communications

The OPTC2 fieldbus board provides communication between the 9000X Drive and a Johnson Controls Metasys™ N2 network. With this connection, the drive can be controlled, monitored and programmed from the Metasys system. The N2 fieldbus is available as a factory-installed option and as a field-installable kit.

Modbus/TCP Network Communications

The Modbus/TCP Network Card OPTC1 is used for connecting the 9000X Drive to Ethernet networks using Modbus protocol. It includes an RJ-45 pluggable connector. This interface provides a selection of standard and custom register values to communicate drive parameters. The board supports 10 Mbps and 100 Mbps communication speeds. The IP address of the board is configurable over Ethernet using a supplied software tool.

BACnet Network Communications

The BACnet Network Card OPTCJ is used for connecting the 9000X Drive to BACnet networks. It includes a 5.08 mm pluggable connector. Data transfer is Master-Slave/Token Passing (MS/TP) RS-485. This interface uses a collection of 30 Binary Value Objects (BVOs) and 35 Analog Value Objects (AVOs) to communicate drive parameters. The card supports 9.6, 19.2 and 38.4 Kbaud communication speeds and supports network addresses 1 to 127.

Ethernet/IP Network Communications

The Ethernet/IP Network Card OPTCK is used for connecting the 9000X Drive to Ethernet/Industrial Protocol networks. It includes an RJ-45 pluggable connector. The interface uses CIP objects to communicate drive parameters (CIP is "Common Industrial Protocol," the same protocol used by DeviceNet). The board supports 10 Mbps and 100 Mbps communication speeds. The IP address of the board is configurable by Static, BOOTP and DHCP methods.

Control/Communication Option Descriptions

Available Control/Communications Options

2

Option	Description	Option Type
K1	Door-Mounted Speed Potentiometer —Provides the drive with the ability to adjust the frequency reference using a door-mounted potentiometer. This option uses the 10 Vdc reference to generate a 0–10V signal at the analog voltage input signal terminal. When the HOA bypass option is added, the speed is controlled when the HOA switch is in the HAND position. Without the HOA bypass option, a two-position switch (labeled local/remote) is provided on the keypad to select speed reference from the speed potentiometer or a remote speed signal.	Control
K2	Door-Mounted Speed Potentiometer with HOA Selector Switch —Provides the drive with the ability to start/stop and adjust the speed reference from door-mounted control devices or remotely from customer supplied inputs. In HAND position, the drive will start and the speed is controlled by the door-mounted speed potentiometer. The drive will be disabled in the OFF position. When AUTO is selected, the drive run and speed control commands are via user-supplied dry contact and 4–20 mA signal.	Control
K3	3–15 psig Follower —Provides a pneumatic transducer which converts a 3–15 psig pneumatic signal to either 0–8 Vdc or a 1–9 Vdc signal interface with the drive. The circuit board is mounted on the inside of the front enclosure panel and connects to the user's pneumatic control system via 6 ft (1.8m) of flexible tubing and a 1/4 in (6.4 mm) brass tube union.	Control
K4	HAND/OFF/AUTO Switch for Non-Bypass Configurations —Provides a three-position selector switch that allows the user to select either a HAND or AUTO mode of operation. HAND mode is defaulted to keypad operation, and AUTO mode is defaulted to control from an external terminal source. These modes of operation can be configured via drive programming to allow for alternate combinations of start and speed sources. Start and speed sources include keypad, I/O and fieldbus.	Control
K5	MANUAL/AUTO Speed Reference Switch —Provides door-mounted selector switch for MANUAL/AUTO speed reference.	Control
K6	START/STOP Pushbuttons —Provide door-mounted START and STOP pushbuttons for either bypass or non-bypass configurations.	Control
KF	Bypass Test Switch for RB and RA —Allows the user to energize the AF drive for testing while operating the motor on the bypass controller. The Test Switch is mounted on the inside of the enclosure door.	Addl. bypass
K0	Standard Elapsed Time Meter —Provides a door-mounted elapsed run time meter.	Control
L1	Power On, Run and Fault Lights —Provide a white power on light that indicates power to the enclosed cabinets, a green run light and a red fault light that indicates a drive fault has occurred.	Light
L2	Bypass Pilot Lights for RB, RA Bypass Options —A green light indicates when the motor is running in inverter mode and an amber light indicates when the motor is running in bypass mode. The lights are mounted on the enclosure door, above the switches.	Addl. bypass
LE	Red Run Pilot Light (22 mm) —Provides a red run pilot light that indicates the drive is running.	Light
P1	Input Circuit Breaker —High interrupting circuit breaker that provides a means of short-circuit protection for the power cables between it and the enclosed 18-pulse drive, and protection from high-level ground faults on the power cable. Allows a convenient means of disconnecting the enclosed 18-pulse drive from the line and the operating mechanism can be padlocked in the OFF position. This is factory mounted in the enclosure. Standard rating is 65 kAIC at 208/480V. 100 kAIC is available as an option.	Input
P3	Input Line Fuses Rated to 200 kAIC —Provide high-level fault protection of the drive input power circuit from the load side of the fuses to the input side of the power transistors. This option consists of three 200 kA fuses, which are factory mounted in the enclosure.	Input
P7	MOV Surge Suppressor —Provides a Metal Oxide Varistor (MOV) connected to the line side terminals and is designed to clip line side transients.	Input
P8	TVSS Surge Protective Device with 50 kA Rating —Provides transient voltage protection eliminating surges and spikes which can damage the diode bridge of the drive.	Input
PC	Capacitor Contactor —This option provides a contactor between the tuned reactor and capacitor to disconnect the capacitor from the circuit when desired, typically at light or no load conditions. This contactor is wired to a programmable relay output.	Input
PE	Output Contactor —Provides a means for positive disconnection of the drive output from the motor terminals. The contactor coil is controlled by the drive's run or permissive logic. NO auxiliary contacts rated at 10A, 600 Vac are provided for customer use. Bypass options RB and RA include an output contactor as standard. This option includes a low VA 115 Vac fused control power transformer and is factory mounted in the enclosure.	Output
PF	Output Filter —Used to reduce the transient voltage (DV/DT) at the motor terminals. The output filter is recommended for cable lengths exceeding 100 ft (30m) or for a drive rated at 525–690V. This option is mounted in the enclosure, and may be used in conjunction with a brake chopper circuit.	Output
PG	MotoRx (300–600 ft) 1000 V/μS DV/DT Filter —Used to reduce transient voltage (DV/DT) and peak voltages at the motor terminals. This option is comprised of a 0.5% line reactor, followed by capacitive filtering and an energy recovery/clamping circuit. Unlike the output filter (see option PF), the MotoRx recovers most of the energy from the voltage peaks, resulting in a lower voltage drop to the motor, and therefore conserving power. This option is used when the distance between a single motor and the drive is 300–600 ft (91–183m). <i>This option cannot be used with the brake chopper circuit. The output filter (option PF) should be investigated as an alternative.</i>	Output
PH	Single Overload Relay —Uses a bimetallic overload relay to provide additional overload current protection to the motor on configurations without bypass options. It is included with the bypass configurations for overload current protection in the bypass mode. The overload relay is mounted within the enclosure, and is manually resettable. Heater pack included.	Output
PI	Dual Overload Relays —This option is recommended when a single drive is operating two motors and overload current protection is needed for each of the motors. The standard configuration includes two bimetallic overload relays, each sized to protect a motor with 50% of the drive hp rating. For example, a 100 hp drive would include two overload relays sized to protect two 50 hp motors. The relays are mounted within the enclosure, and are manually resettable. Heater packs not included.	Output
PN	Dual Overloads for Bypass —This option is recommended when a single drive is operating two motors in the bypass mode and overload current protection is needed for each of the motors. The standard configuration includes two bimetallic overload relays, each sized to protect a motor with 50% of the drive hp rating. For example, a 100 hp drive would include two overload relays sized to protect two 50 hp motors. The relays are mounted within the enclosure, and are manually resettable.	Addl. bypass

Available Control/Communications Options, continued

Option	Description	Option Type
RA	Manual HOA Bypass Controller —The manual HAND/OFF/AUTO (HOA)—three-contactor—bypass option provides a means of bypassing the enclosed passive filtered drive, allowing the AC motor to be operated at full speed directly from the AC supply line. This option consists of an input HMCP, a fused control power transformer, and a full voltage bypass starter with a door-mounted HOA selector switch and an INVERTER/BYPASS switch. The HOA switch provides the ability to start and stop the drive in the inverter mode. IEC type input, bypass and input contactors are provided. The contactors are mechanically and electrically interlocked (see wiring diagram on Page V6-T2-223).	Bypass
RB	Manual IOB Bypass Controller —The manual INVERTER/OFF/BYPASS (IOB)—three-contactor—bypass option provides a means of bypassing the enclosed passive filtered drive, allowing the AC motor to be operated at full speed directly from the AC supply line. This option consists of an input HMCP, a fused control power transformer, and a full voltage bypass starter with a door-mounted IOB selector switch. IEC type input, bypass and input contactors are provided. The contactors are mechanically and electrically interlocked (see wiring diagram on Page V6-T2-223).	Bypass
RC	Auto Transfer HOA Bypass Controller —The manual HAND/OFF/AUTO (HOA)—three-contactor—bypass option provides a means of bypassing the enclosed passive filtered drive, allowing the AC motor to be operated at full speed directly from the AC supply line. The circuitry provides an automatic transfer of the load to “across the line” operation after a drive trip. This option consists of an input HMCP, a fused control power transformer, and a full voltage bypass starter with a door-mounted HOA selector switch and an INVERTER/BYPASS switch. The HOA switch provides the ability to start and stop the drive in either mode. IEC type input, bypass and input contactors are provided. The contactors are mechanically and electrically interlocked (see wiring diagram on Page V6-T2-223). Door-mounted pilot lights are provided that indicate bypass or inverter operation. A green light indicates when the motor is running in inverter mode and an amber light indicates when the motor is running in bypass mode. WARNING: The motor may restart when the overcurrent relay is reset when operating in bypass, unless the IOB selector switch is turned to the OFF position.	Bypass
RD	Auto Transfer IOB Bypass Controller —The auto INVERTER/OFF/BYPASS (IOB)—three-contactor—bypass option provides a means of bypassing the enclosed passive filtered drive, allowing the AC motor to be operated at full speed directly from the AC supply line. The circuitry provides an automatic transfer of the load to “across the line” operation after a drive trip. This option consists of an input HMCP, a fused control power transformer, and a full voltage bypass starter with a door-mounted IOB selector switch. IEC type input, bypass and input contactors are provided. The contactors are mechanically and electrically interlocked (see wiring diagram on Page V6-T2-223). Door-mounted pilot lights are provided that indicate bypass or inverter operation. A green light indicates when the motor is running in inverter mode and an amber light indicates when the motor is running in bypass mode. WARNING: The motor may restart when the overcurrent relay is reset when operating in bypass, unless the IOB selector switch is turned to the OFF position.	Bypass
RG	Reduced Voltage Starter for Bypass —Used in conjunction with bypass option RA, RB, RC or RD. This option adds IT . Series reduced voltage soft starter to bypass assembly for soft starting in bypass mode.	Bypass
S4	Floor Stand 6 in —Raises “F” box off the ground 6 in (152.4 mm). Recommended when box is not installed on an appropriate concrete pad.	Enclosure
S5	Floor Stand 22 in —Converts a Size B or C, normally wall mounted enclosure to a floor standing enclosure with a height of 22 in (558.8 mm).	Enclosure
S6	Floor Stand 12 in —Converts a Size C or D, normally wall mounted enclosure to a floor standing enclosure with a height of 12 in (304.8 mm).	Enclosure
S9	Space Heater —Prevents condensation from forming in the enclosure when the drive is inactive or in storage. Includes a thermostat for variable temperature control. Heater requires a customer supplied 115V remote supply source.	Enclosure

Enclosed Drive Options

Conformal (Varnished) Coating ^①

Chassis Frame	Delivery Code	Chassis Frame	Delivery Code
FR6	FP	FR9	FP
FR7	FP	FR10	FP
FR8	FP	FR11	FP
—	—	FR12	FP

Light Options

Description	Catalog Number Suffix
Power on, run, fault LED lights (22 mm)	L1
Power on, fault LED lights (22 mm)	L3
Green LED run light (22 mm)	LA
Green LED stop light (22 mm)	LD
Red LED run light (22 mm)	LE
Red LED stop light (22 mm)	LF
Red LED fault light (22 mm)	LG
Power on white LED light (22 mm)	LJ
Miscellaneous LED light (22 mm)	LU

Control Options

Description	Catalog Number Suffix
Door-mounted speed potentiometer	K1
Door-mounted speed potentiometer with HOA selector switch	K2
3–15 psig follower	K3
HOA selector switch	K4
MANUAL/AUTO reference switch	K5
START-STOP pushbuttons	K6
Type D2 control relay	SD
On-delay relay	SE
Off-delay relay	SF
Additional terminal blocks per 4 points	SD

Note

^① See catalog number description to order.

Bypass Control Options

Description	Catalog Number Suffix
Bypass test switch used with RA and RB	KF
Inverter/bypass pilot lights	L2

Meter Options

Description	Catalog Number Suffix
Standard elapsed time meter	K0
Frequency meter	KS
MP-3000 relay with URTD	KV
MP-3000 relay with URTD and CTs	KU

Enclosure Options

Enclosure Size	Catalog Number Suffix
Space Heater ^①	
7	S9
8	S9
9	S9
B	S9
C	S9
D	S9
F	S9
Plastic Nameplate	
All	SN
Floor Stand/Enclosure Size	
6 in floor stand, size F	S4
22 in floor stand, size B and C	S5
12 in floor stand, size C and D	S6

208V Power Options, 7-1/2–100 hp

Description	Catalog Number Suffix
Input breaker	P1
Input line fusing	P2
Input line fuses 200 kAIC	P3
Output contactor	PE
Single overload relay	PH
Dual overload relays	PI
MOV	P7
50 kA surge protective device	P8
100 kA surge protective device	P9

230V Power Options, 7-1/2–125 hp

Description	Catalog Number Suffix
Input breaker	P1
Input line fusing	P2
Input line fuses 200 kAIC	P3
Output contactor	PE
Single overload relay	PH
Dual overload relays	PI
MOV	P7
50 kA surge protective device	P8
100 kA surge protective device	P9

480 and 575V Power Options, 7-1/2–400 hp

Description	Catalog Number Suffix
Input breaker	P1
Input line fusing	P2
Input line fuses 200 kAIC	P3
Output contactor	PE
Output filter	PF
MotoRx (300–600 ft) DV/DT filter	PG
Single overload relay	PH
Dual overload relays	PI
Input MOV	P7
50 kA surge protective device	P8
100 kA surge protective device	P9

208V Bypass Options, 7-1/2–100 hp

Description	Catalog Number Suffix
Manual HOA bypass controller	RA
IOB bypass controller	RB
Auto transfer HOA bypass controller	RC
Auto transfer IOB bypass controller	RD
Reduced voltage starter for bypass	RG
Dual overloads for bypass	PN

230V Bypass Options, 7-1/2–125 hp

Description	Catalog Number Suffix
Manual HOA bypass controller	RA
IOB bypass controller	RB
Auto transfer HOA bypass controller	RC
Auto transfer IOB bypass controller	RD
Reduced voltage starter for bypass	RG
Dual overloads for bypass	PN

480 and 575V Bypass Options, 7-1/2–400 hp

Description	Catalog Number Suffix
Manual HOA bypass controller	RA
IOB bypass controller	RB
Auto transfer HOA bypass controller	RC
Auto transfer IOB bypass controller	RD
Reduced voltage starter for bypass	RG
Dual overloads for bypass	PN

Note

① Requires customer-supplied 115 Vac supply.

Technical Data and Specifications

Enclosed Passive Filtered Drives

Description	Specification
Primary Design Features	
45–66 Hz input frequency	Standard
Output: AC volts maximum	Input Voltage Base
Output frequency range	0–320 Hz
Initial output current (I_H)	250% for 2 seconds
Overload (1 minute [I_H/I_L])	150%/110%
Enclosure space heater	Optional
Oversize enclosure	Standard
Output contactor	Optional
Bypass motor starter	Optional
Listings	UL, cUL, 508C
Protection Features	
Incoming line fuses	Optional
AC input circuit disconnect	Optional
Phase rotation insensitive	Standard
EMI filter	Standard—FR6 thru FR9 ^①
Input phase loss protection	Standard
Input overvoltage protection	Standard
Line surge protection	Standard
Output short-circuit protection	Standard
Output ground fault protection	Standard
Output phase protection	Standard
Overtemperature protection	Standard
DC overvoltage protection	Standard
Drive overload protection	Standard
Motor overload protection	Standard
Programmer software	Optional
Local/remote keypad	Standard
Keypad lockout	Standard
Fault alarm output	Standard
Built-in diagnostics	Standard
Surge protective device	Optional

Description	Specification
Input/Output Interface Features	
Setup adjustment provisions	
Remote keypad/display	Standard
Personal computer	Standard
Operator control provisions	
Drive mounted keypad/display	Standard
Remote keypad/display	Standard
Conventional control elements	Standard
Serial communications	Optional
115 Vac control circuit	Optional
Speed setting inputs	
Keypad	Standard
0–10 Vdc potentiometer/voltage signal	Standard
4–20 mA isolated	Configurable
4–20 mA differential	Configurable
3–15 psig	Optional
Analog outputs	
Speed/frequency	Standard
Torque/load/current	Programmable
Motor voltage	Programmable
Kilowatts	Programmable
0–10 Vdc signals	Configurable w/jumpers
4–20 mA DC signals	Standard
Isolated signals	Optional
Discrete outputs	
Fault alarm	Standard
Drive running	Standard
Drive at set speed	Programmable
Optional parameters	14
Dry contacts	2 relays Form C
Open collector outputs	1
Additional discrete outputs	Optional
Communications	
RS-232	Standard
RS-422/485	Optional
DeviceNet™	Optional
Modbus RTU	Optional
CANopen (slave)	Optional
PROFIBUS-DP	Optional
Lonworks®	Optional
Johnson Controls Metasys™ N2	Optional
EtherNet/IP/Modbus TCP	Optional
BACnet	Optional

Note

^① The EMI filter is optional in FR10.

Enclosed Passive Filtered Drives, continued

Description	Specification
Performance Features	
Sensorless vector control	Standard
Volts/hertz control	Standard
IR and slip compensation	Standard
Electronic reversing	Standard
Dynamic braking	Optional
DC braking	Standard
PID setpoint controller	Programmable
Critical speed lockout	Standard
Current (torque) limit	Standard
Adjustable acceleration/deceleration	Standard
Linear or S curve accel/decel	Standard
Jog at preset speed	Standard
Thread/preset speeds	7
Automatic restart	Selectable
Coasting motor start	Standard
Coast or ramp stop selection	Standard
Elapsed time meter	Optional
Standard Conditions for Application and Service	
Maximum operating ambient temperature	0 to 40°C, contact factory for 50°C ^①
Storage temperature	-40 to 60°C
Humidity (maximum), non-condensing	95%
Altitude	100% load capacity (no derating) up to 3280 ft (1000m); 1% derating for each 328 ft (100m) above 3280 ft (1000m); max. 9842 ft (3000m)
Line voltage variation	+10/-15%
Line frequency variation	45-66 Hz
Efficiency	>96%
Power factor (displacement)	0.99

Standard I/O Specifications

Description	Specification
Six-digital input programmable	24V: "0" ≤10V, "1" ≥18V, R _i >5 kohms
Two-analog input configurable w/ jumpers	Voltage: 0-±10V, R _i >200 kohms Current: 0 (4)-20 mA, R _i = 250 kohms
Two-digital output programmable	Form C relays 250 Vac or 30 Vdc 2 Amp resistive
One-digital output programmable	Open collector 48 Vdc 50 mA
One-analog output programmable configurable w/jumper	0-20 mA, R _L max. 500 ohms 10 bits ±2%

I/O Specifications for Control/Communication Options

Description	Specification
Analog voltage, input	0-±10V, R _i ≥200 kilohms
Analog current, input	0 (4)-20 mA, R _i = 250 ohms
Digital input	24V: "0" ≤10V, "1" ≥18V, R _i >5 kilohms
Auxiliary voltage	24V (±20%), max. 50 mA
Reference voltage	10V ±3%, max. 10 mA
Analog current, output	0 (4)-20 mA, R _L = 500 kilohms, resolution 10 bit, accuracy ≤±2%
Analog voltage, output	0 (2)-10V, R _L ≥1 kohm, resolution 10 bit, accuracy ≤±2%
Relay output max. switching voltage	300 Vdc, 250 Vac
Relay output max. switching load	3A/24 Vdc, 300 Vdc, 250 Vac ^②
Relay output max. continuous load	2A rms
Thermistor input	R _{trip} = 4.7 kohms

Notes

① Units FR10 rated 40°C.

② For applications above 3A consult instruction manual.

Wiring Diagram

Control Input/Output

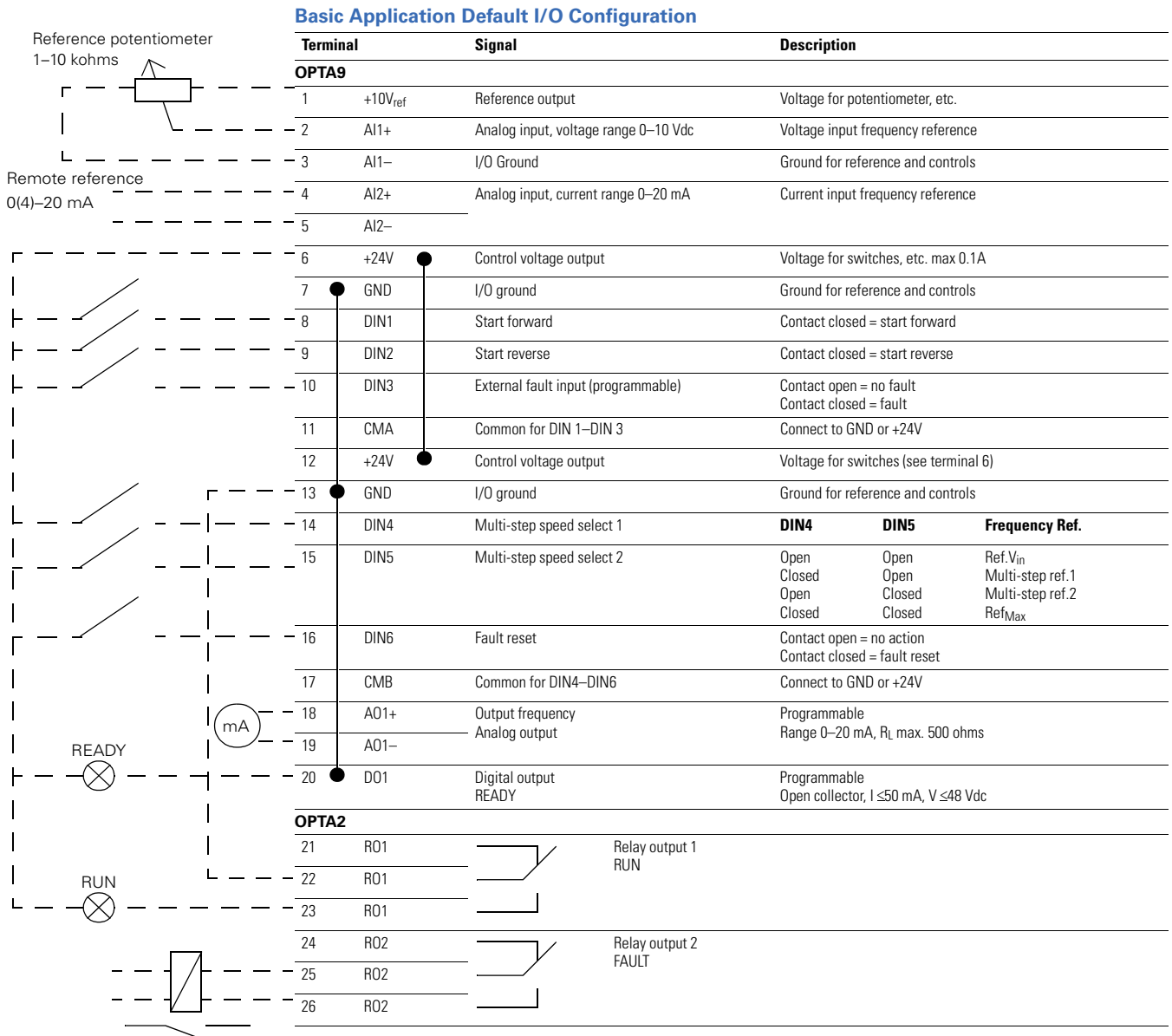

2.8

Adjustable Frequency Drives

Low Harmonic Drives

Dimensions

Approximate Dimensions in Inches (mm)

2

Enclosure Size B—UL Type 12

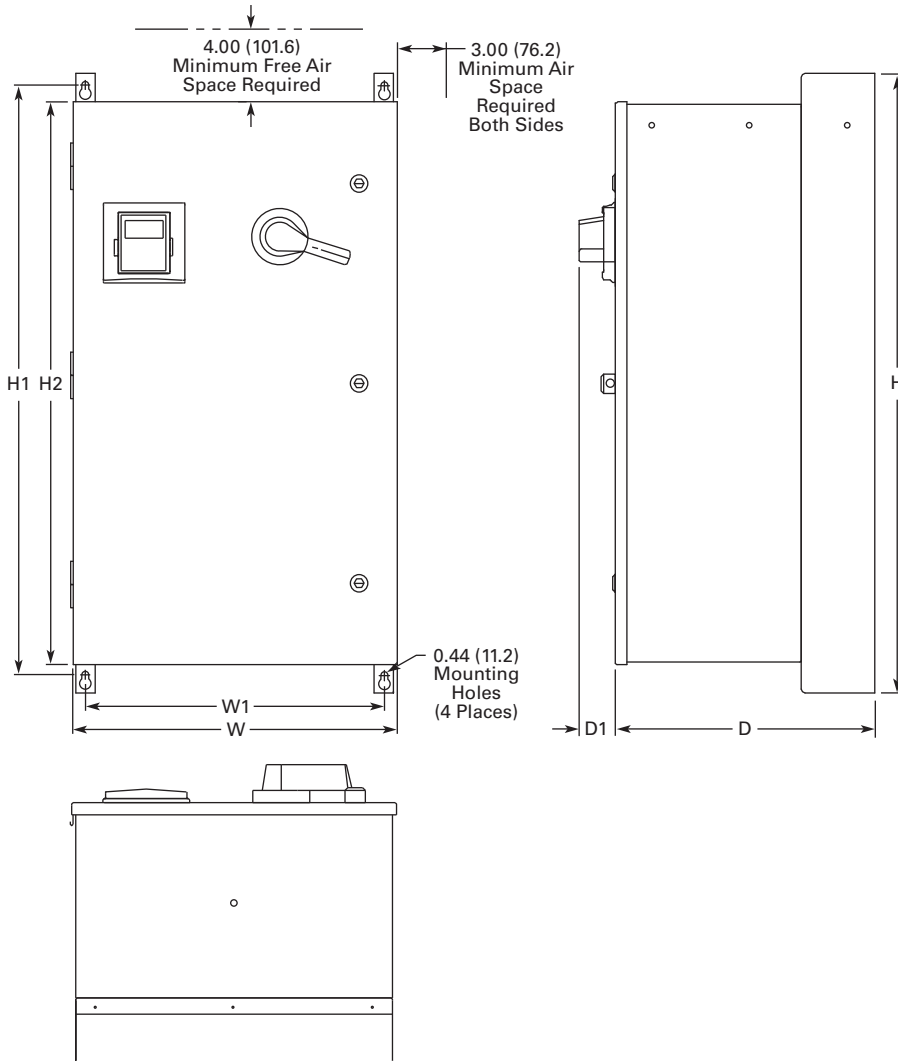

H	H1	H2	W	W1	D	D1	Approximate Weight Lbs (kg)	Approximate Shipping Weight Lbs (kg)
40.00 (1016.0)	38.00 (965.2)	36.35 (923.3)	20.92 (531.4)	19.30 (490.2)	16.76 (425.7)	2.34 (59.4)	185 (84)	229 (104)

Approximate Dimensions in Inches (mm)

Enclosure Size C—UL Type 12

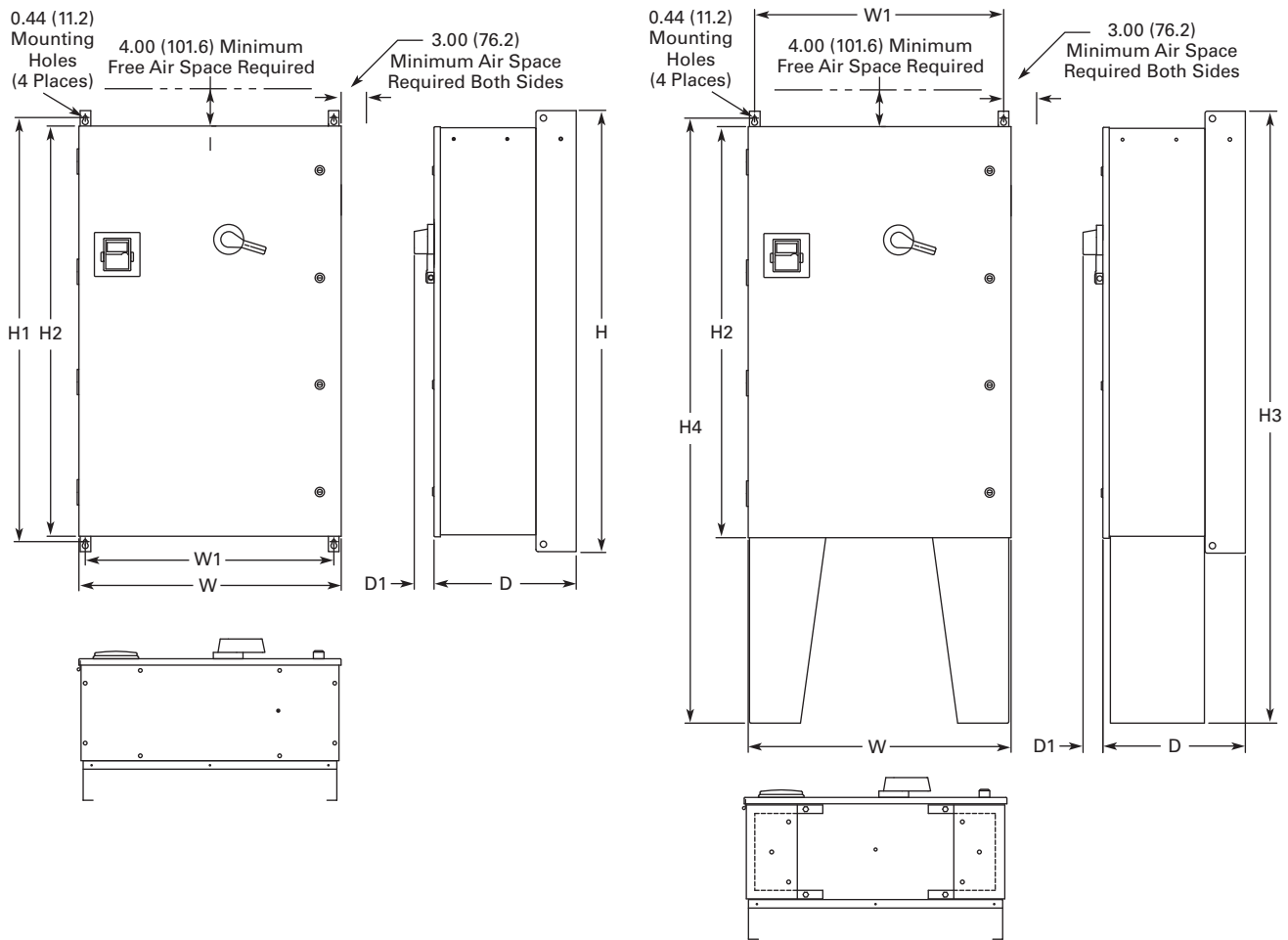

H	H1	H2	H3	H4	W	W1	D	D1	Approximate Weight Lbs (kg)	Approximate Shipping Weight Lbs (kg)
52.00 (1320.8)	50.00 (1270.0)	48.35 (1228.1)	72.00 (1828.8)	71.19 (1808.2)	30.92 (785.4)	29.30 (744.2)	16.78 (426.2)	2.34 (59.4)	320 (145)	435 (197)

2.8

Adjustable Frequency Drives

Low Harmonic Drives

Approximate Dimensions in Inches (mm)

Enclosure Size B—UL Type 3R

2

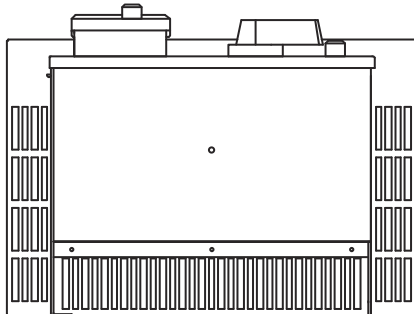
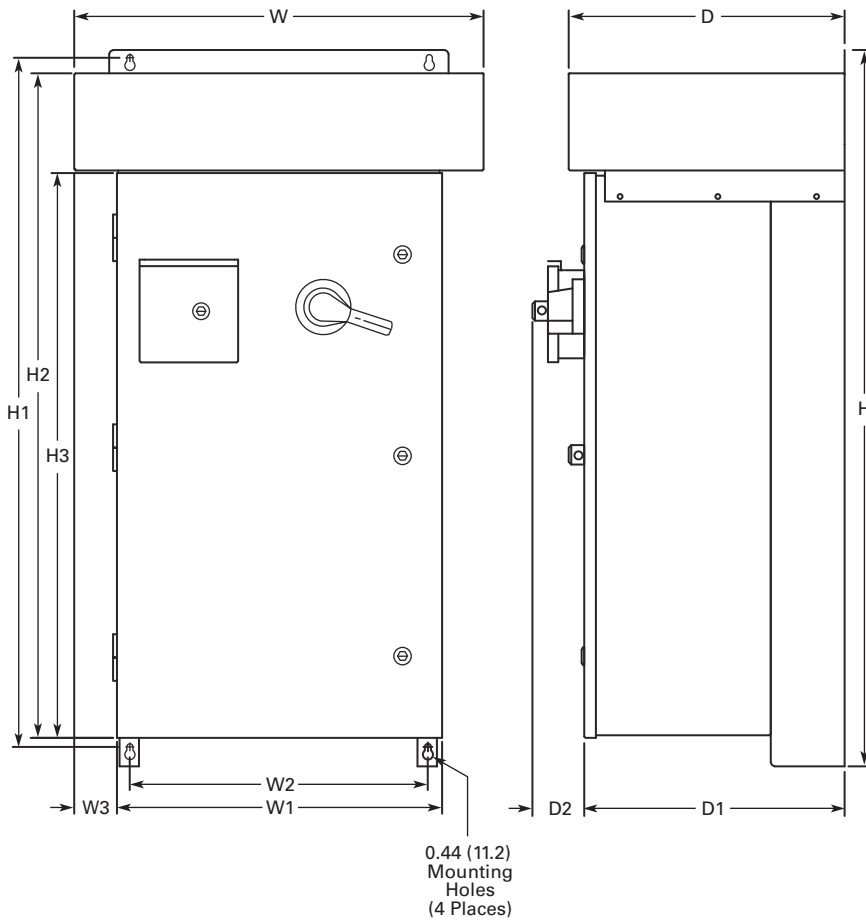

H	H1	H2	H3	W	W1	W2	W3	D	D1	D2	Approximate Weight Lbs (kg)	Approximate Shipping Weight Lbs (kg)
46.09 (1170.7)	44.45 (1129.0)	42.77 (1086.4)	36.35 (923.3)	26.31 (668.3)	20.92 (531.4)	19.30 (490.2)	2.69 (68.3)	17.74 (450.6)	16.76 (425.7)	3.31 (84.1)	235 (107)	290 (132)

Approximate Dimensions in Inches (mm)

Enclosure Size C—UL Type 3R

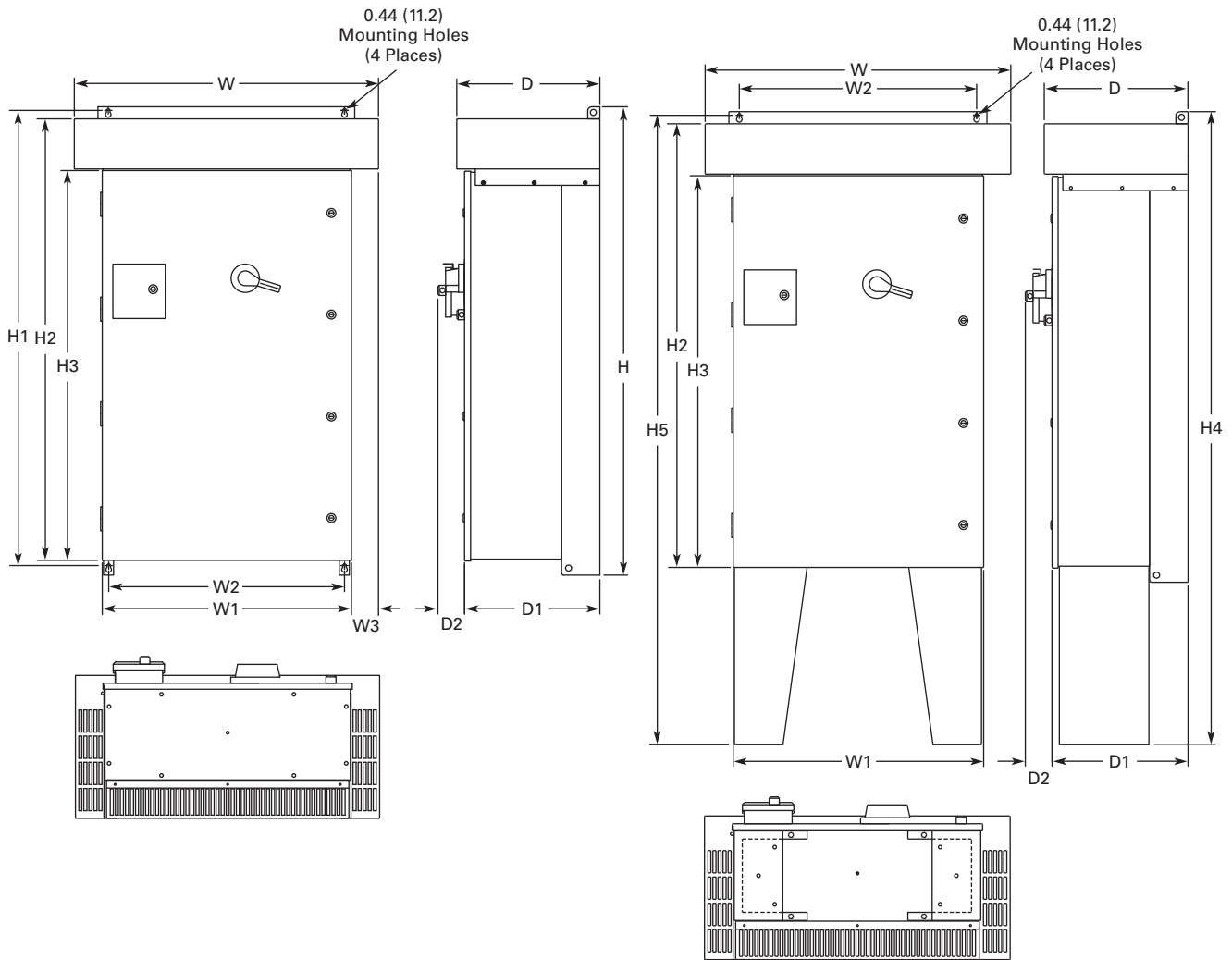

H	H1	H2	H3	H4	H5	W	W1	W2	W3	D	D1	D2	Approximate Weight Lbs (kg)	Approximate Shipping Weight Lbs (kg)
58.09 (1475.5)	56.45 (1433.8)	54.77 (1391.2)	48.35 (1228.1)	78.09 (1983.5)	77.64 (1972.1)	37.73 (958.3)	30.92 (785.4)	29.30 (744.2)	3.34 (84.8)	17.74 (450.6)	16.77 (426.0)	3.31 (84.1)	370 (168)	485 (220)

2.8

Adjustable Frequency Drives

Low Harmonic Drives

Approximate Dimensions in Inches (mm)

Enclosure Size D—UL Type 3R

2

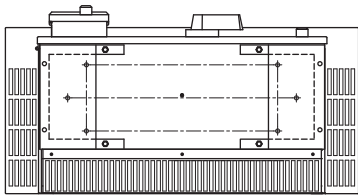
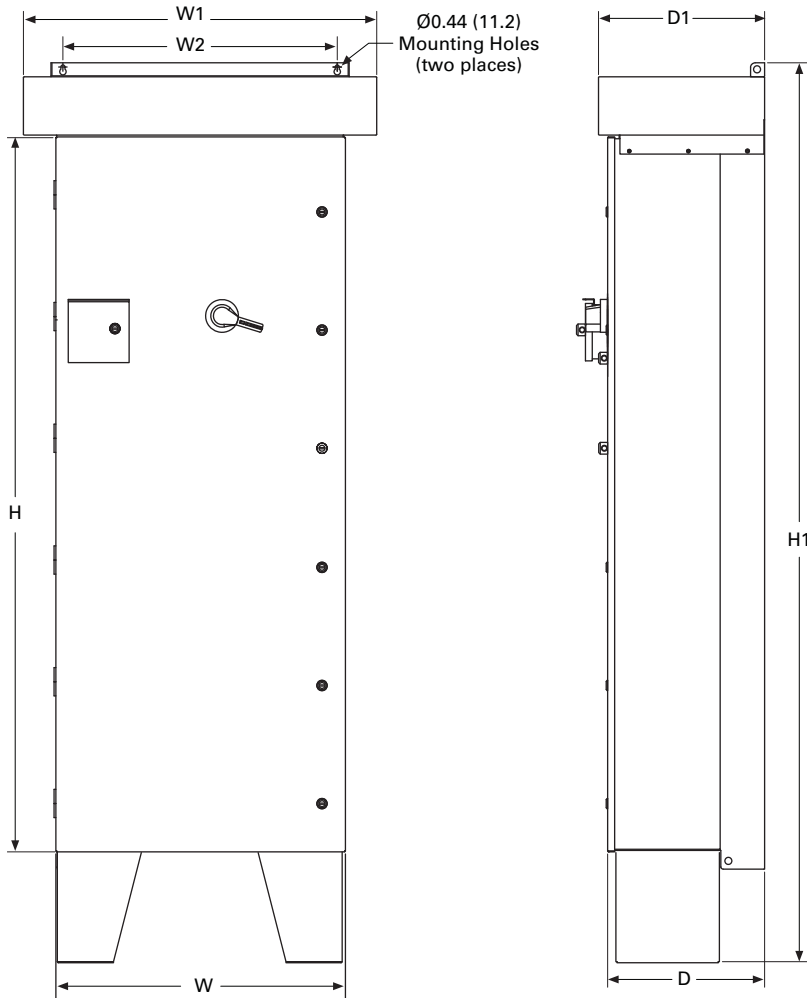

H	H1	W	W1	W2	D	D1	Approximate Shipping Weight Lbs (kg)
76.27 (1937.3)	96.00 (2438.4)	30.92 (784.4)	37.73 (958.3)	29.30 (744.2)	16.76 (424.7)	17.74 (450.6)	1000 (454)

Note
Shown with optional floor stands.

Approximate Dimensions in Inches (mm)

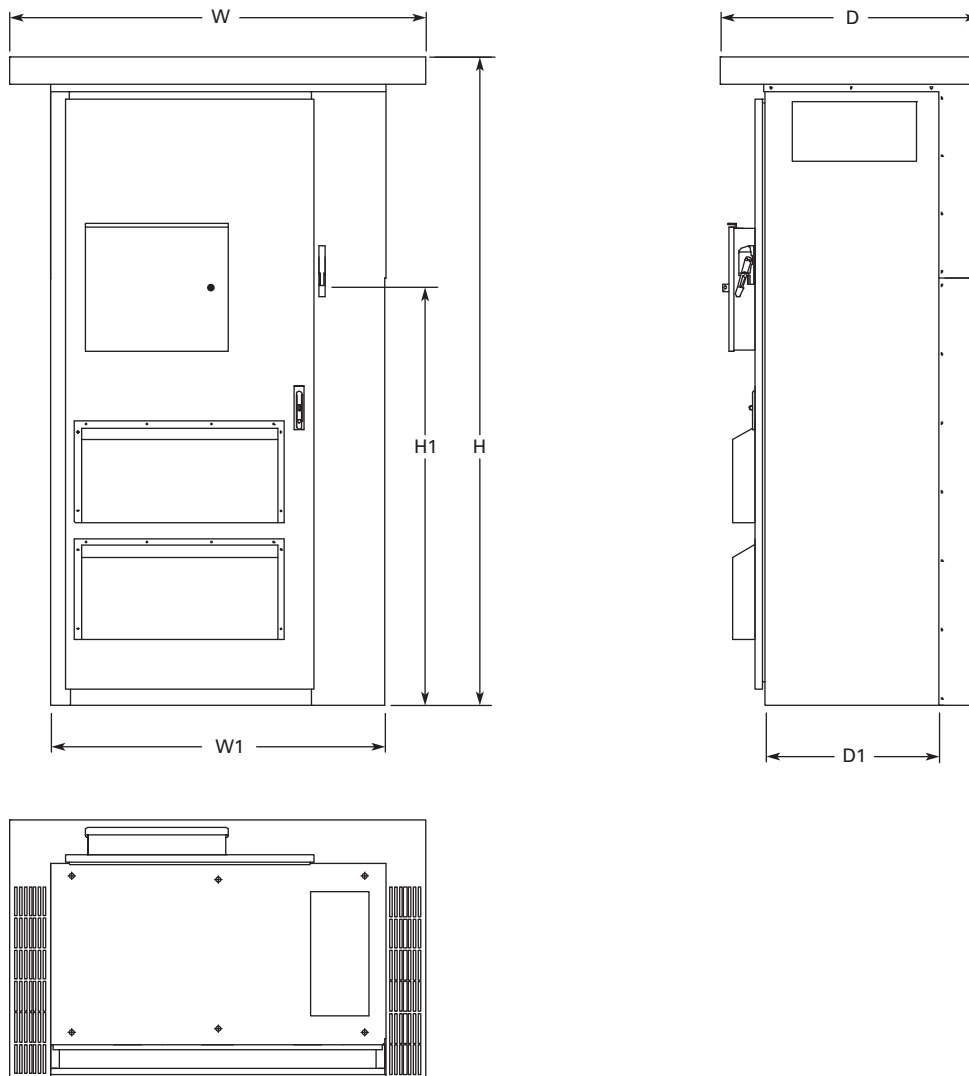
Enclosure Size F

H	H1	W	W1	D	D1	Approximate Weight Lbs (kg)	Approximate Shipping Weight Lbs (kg)
93.58 (2376.9)	69.51 (1765.60)	60.00 (1524.0)	48.00 (1219.2)	37.50 (952.5)	26.00 (660.4)	1700 (771)	1850 (839)

2.8

Adjustable Frequency Drives

Low Harmonic Drives

Approximate Dimensions in Inches (mm)

Enclosure Size 7

2

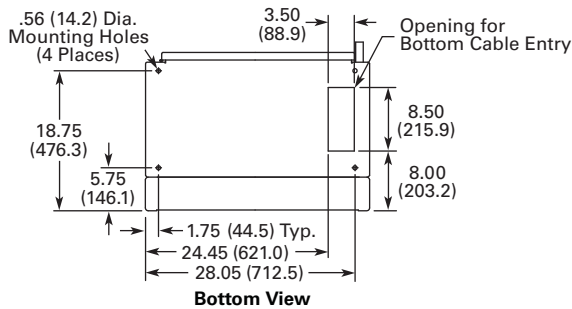
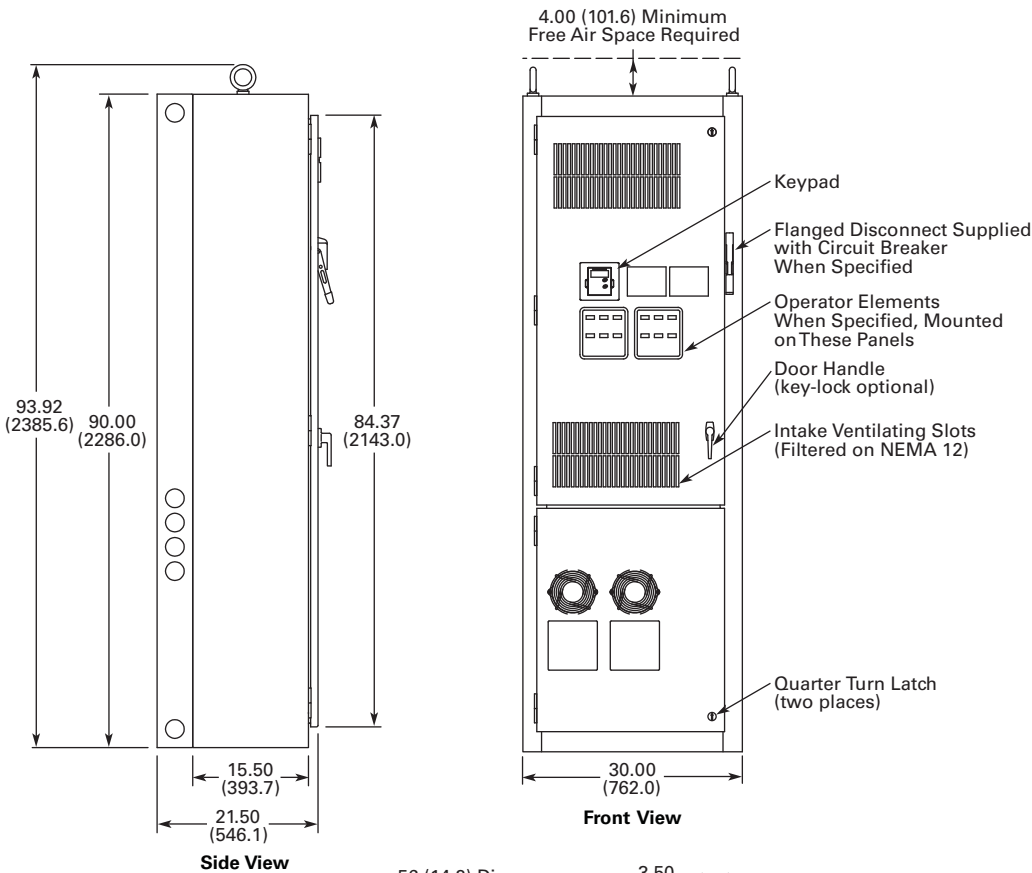
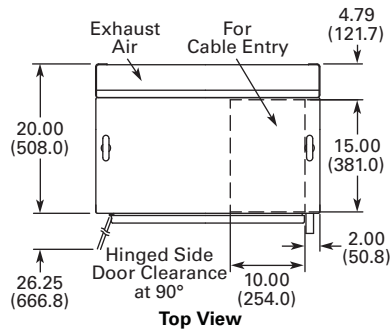

Construction: UL Type 1 Oversize
Finish: Enclosure - ANSI 61 Gray (Light)

Approximate Shipping Weight
Lbs (kg)

1000 (454)

Approximate Dimensions in Inches (mm)

Enclosure Size 8

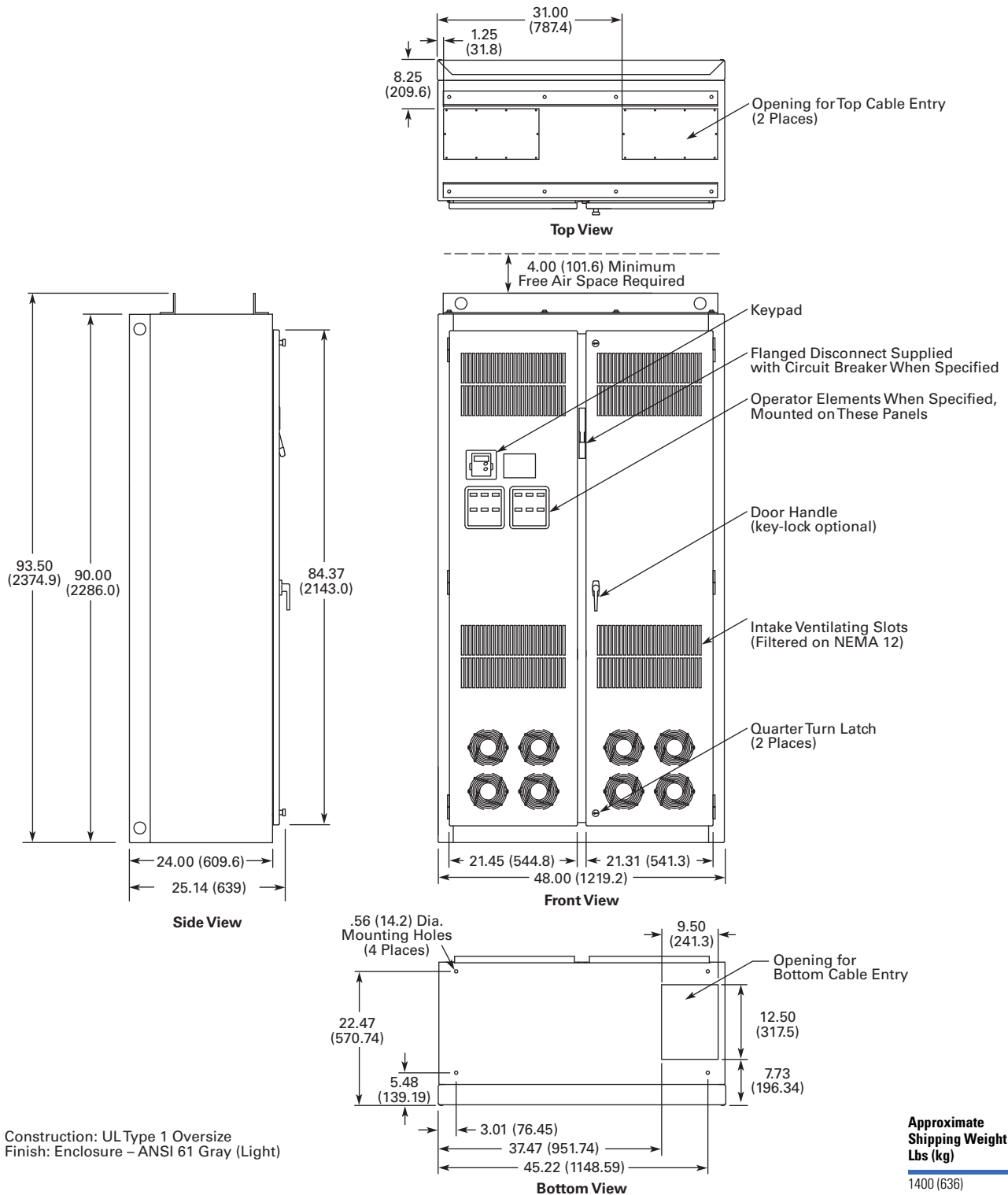

2.8

Adjustable Frequency Drives

Low Harmonic Drives

Approximate Dimensions in Inches (mm)

Enclosure Size 9

2

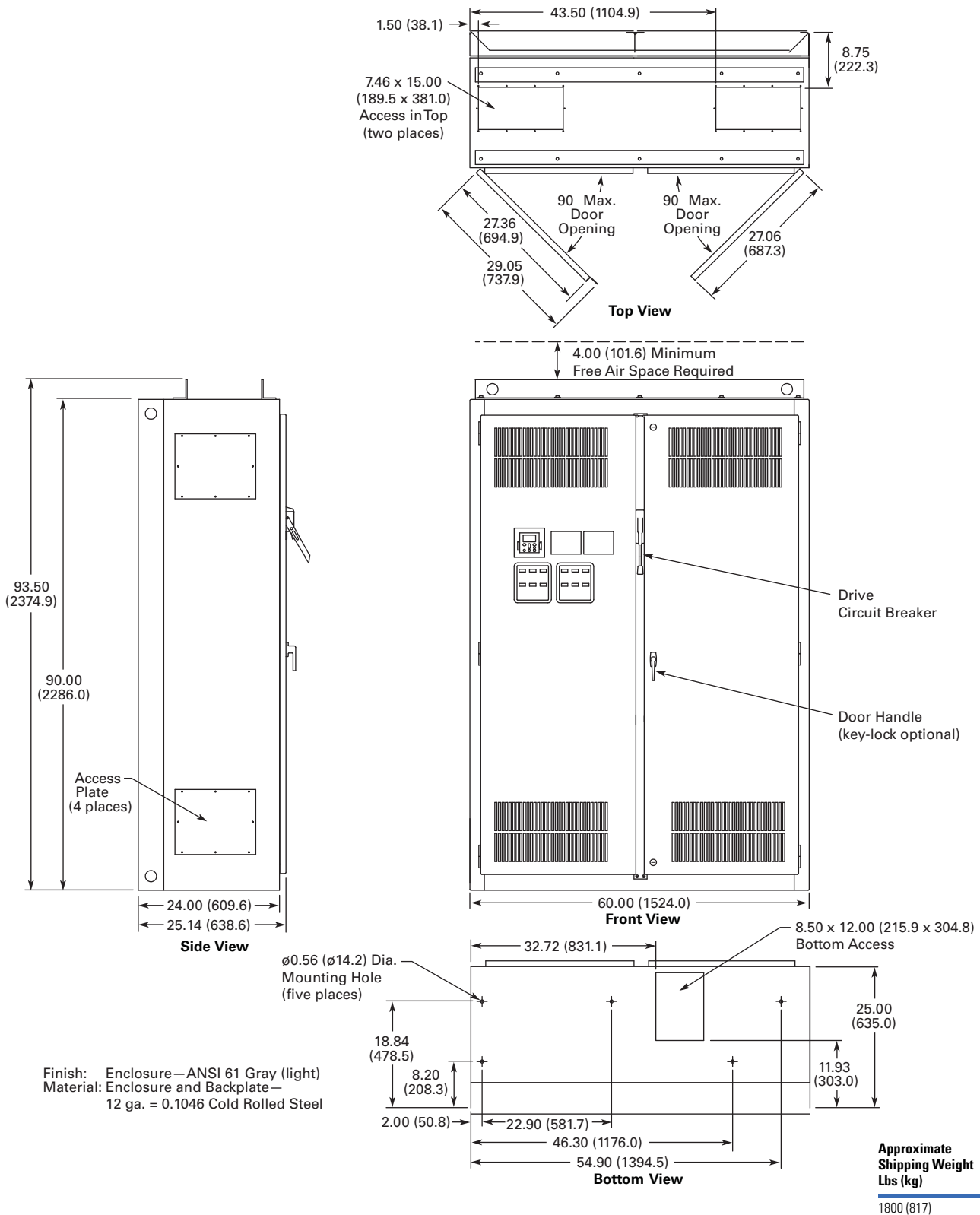

Enclosed 18-Pulse Drives



Enclosed 18-Pulse Drives

Product Description

Eaton's enclosed 18-pulse clean power drives use advanced 18-pulse clean power technology that significantly reduces line harmonics at the drive input terminals, resulting in one of the purest sinusoidal waveforms available.

The enclosed 18-pulse drive also delivers True Power Factor—in addition to reducing harmonic distortion, the enclosed 18-pulse drive prevents upstream transformer overheating and overloading of breakers and feeders, enabling the application of adjustable frequency drives on generators and other high impedance power systems.

All 9000X Series drives are constant torque rated and rated for either high overload (I_H) or low overload (I_L). I_H indicates 150% overload capacity for 1 minute out of 10 minutes. I_L indicates 110% overload capacity for 1 minute out of 10 minutes.

Contents

Description

	Page
Enclosed Passive Filtered Drives	V6-T2-200
Enclosed 18-Pulse Drives	
Application Description	V6-T2-234
Features and Benefits	V6-T2-239
Catalog Number Selection	V6-T2-240
Product Selection	V6-T2-241
Options	V6-T2-249
Technical Data and Specifications	V6-T2-255
Wiring Diagrams	V6-T2-257
Dimensions	V6-T2-258

Enclosed 18-Pulse Drive Products

- **Standard Enclosed**—covers a wide range of the most commonly ordered options. Pre-engineering eliminates the lead time normally associated with customer specific options. Available configurations are listed on **Pages V6-T2-240 and V6-T2-249 to V6-T2-254.**
- **Modified Standard Enclosed**—applies to specific customer requirements that vary from the Standard Enclosed offering, such as the need for an additional indicating light or minor modifications to drawings. *Contact your local sales office for assistance in pricing and lead time.*
- **Custom Engineered**—for those applications with more unique or complex requirements, these are individually engineered to the customer's needs. *Contact your local sales office for assistance in pricing and lead time.*

Application Description

Designed to exceed the IEEE® 519-1992 requirements for harmonic distortion, the enclosed 18-pulse drive is the clear choice for applications in

the water, wastewater, HVAC, industrial and process industries where harmonics are a concern.

What Are Harmonics?

Take a perfect wave with a fundamental frequency of 60 Hz, which is close to what is supplied by the power company.

Perfect Wave

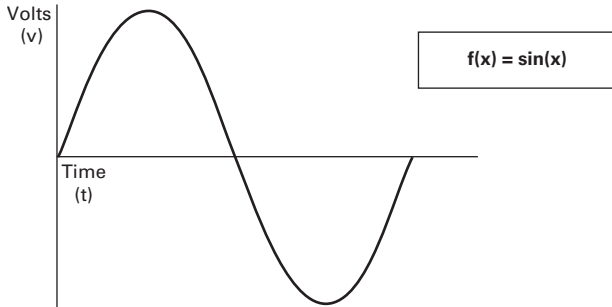

Add a second wave that is five times the fundamental frequency—300 Hz (typical of frequency added to the line by a fluorescent light).

Second Wave

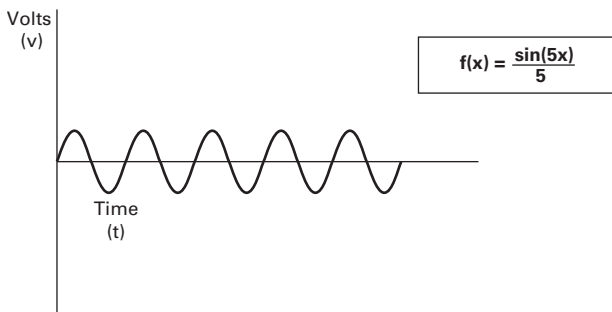

Combine the two waves. The result is a 60 Hz supply rich in fifth harmonics.

Resulting Supply

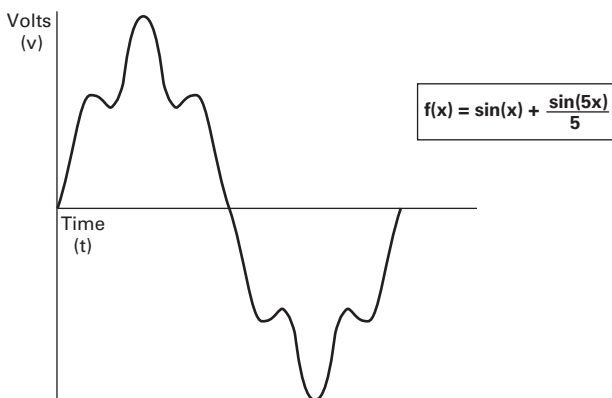

What Causes Harmonics?

Harmonics are the result of nonlinear loads that convert AC line voltage to DC. Examples of equipment that are non-linear loads are listed below:

- AC variable frequency drives
- DC drives
- Fluorescence lighting, computers, UPS systems
- Industrial washing machines, punch presses, welders, etc.

How Can Harmonics Due to VFDs Be Diminished?

By purchasing Eaton's enclosed 18-pulse drive that is guaranteed to meet IEEE Std. 519-1992 Harmonic Distortion Limits.

What Are Linear Loads?

Linear loads are primarily devices that run across the line and do not add harmonics. Motors are prime examples. The downside to having large motor linear loads is that they draw more energy than a VFD, because of their inability to control motor speed. In most applications, there is a turn down valve used with the motor that will reduce the flow of the material, without significantly reducing the load to the motor. While this provides some measure of speed control, it is extremely inefficient.

Why Be Concerned About Harmonics?

1. **Installation and utility costs increase.** Harmonics cause damage to transformers and lower efficiencies due to the IR loss. These losses can become significant and can have a dramatic effect on the HVAC systems that are controlling the temperatures of the building where the transformer and drive equipment reside.
2. **Downtime and loss of productivity.** Telephones and data transmissions links may not be guaranteed to work on the same power grids polluted with harmonics.
3. **Downtime and nuisance trips of drives and other equipment.** Emergency generators have up to three times the impedance that is found in a conventional utility source. Thus the harmonic voltage distortion can be up to three times as large, causing risk of operation problems.
4. **Larger motors must be used.** Motors running across the line that are connected on polluted power distribution grids can overheat or operate at lower efficiency due to harmonics.
5. **Higher installation costs.** Transformers and power equipment must be oversized to accommodate the loss of efficiencies. This is due to the harmonic currents circulating through the distribution without performing useful work.

How Does a VFD Convert Three-Phase AC to a Variable Output Voltage and Frequency?

The six-pulse VFD: The majority of all conventional drives that are built consist of a six-pulse configuration. The figure below represents a six-diode rectifier design that converts three-phase utility power to DC. The inverter section uses IGBTs to convert DC power to a simulated AC sine wave that can vary in frequency from 0–320 Hz.

The six-pulse VFD drive creates harmonic current distortion. The harmonic current that is created is energy that can not be used by customers and causes external heat and losses to all components including other drives that are on the same power distribution. See the curve below showing a 500 hp drive with 167A of damaging harmonic current.

Six-Diode Rectifier Design

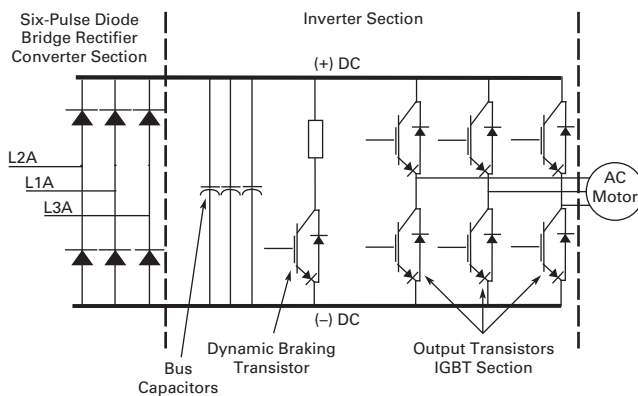

500 hp Six-Pulse Nonproductive Harmonic Current

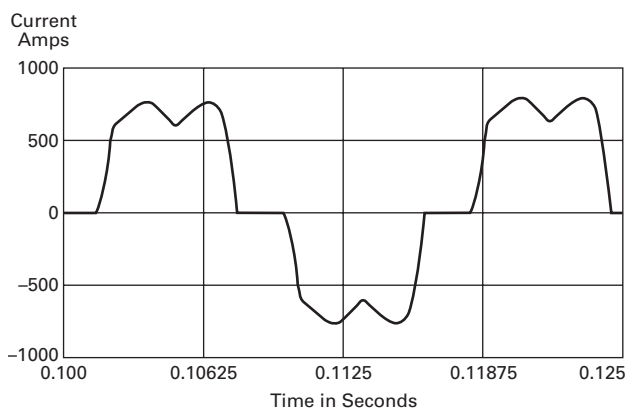

500 hp Six-Pulse Nonproductive Harmonic Current

Six-Pulse Circuit

Current harmonics

$I_1 = 100\%$	$I_{11} = 6.10\%$	$I_{19} = 1.77\%$
$I_5 = 22.5\%$	$I_{13} = 4.06\%$	$I_{23} = 1.12\%$
$I_7 = 9.38\%$	$I_{17} = 2.26\%$	$I_{25} = 0.86\%$

Power = 500 hp

Harmonic current = 167 amps

Guidelines of Meeting IEEE Std. 519-1992 Harmonic Distortion Limits

The IEEE 519-1992 Specification is a standard that provides guidelines for commercial and industrial

users that are implementing medium and low voltage equipment.

Maximum Harmonic Current Distortion in % of the Fundamental (120V through 69,000V)

I_{sc}/I_L	Harmonic Order (Odd Harmonics)					TDD
	$h < 11$	$11 \leq h < 17$	$17 \leq h < 23$	$23 \leq h < 35$	$35 \leq h$	
<20	4.0	2.0	1.5	0.6	0.3	5.0
20<50	7.0	3.5	2.5	1.0	0.5	8.0
50<100	10.0	4.5	4.0	1.5	0.7	12.0
100<1000	12.0	5.5	5.0	2.0	1.0	15.0
>1000	15.0	7.0	6.0	2.5	1.4	20.0

The ratio I_{sc}/I_L is the ratio of the short-circuit current available at the point of common coupling (PCC), to the maximum fundamental load current. Consequently, as the size of the user load decreases with respect to the size of the system, the percentage of harmonic current that the user is allowed to inject into the utility system increases.

Notes

TDD = Total demand distortion is the harmonic current distortion in percent of the maximum demand load current (15 or 30 minute demand).

I_{sc} = Maximum short-circuit current at the PCC not counting motor contribution.

I_L = Maximum demand load current for all of the connected loads (fundamental frequency component) at the PCC. All of the limits are measured at a point of common coupling.

One-Line Diagram for Harmonic Analysis

2

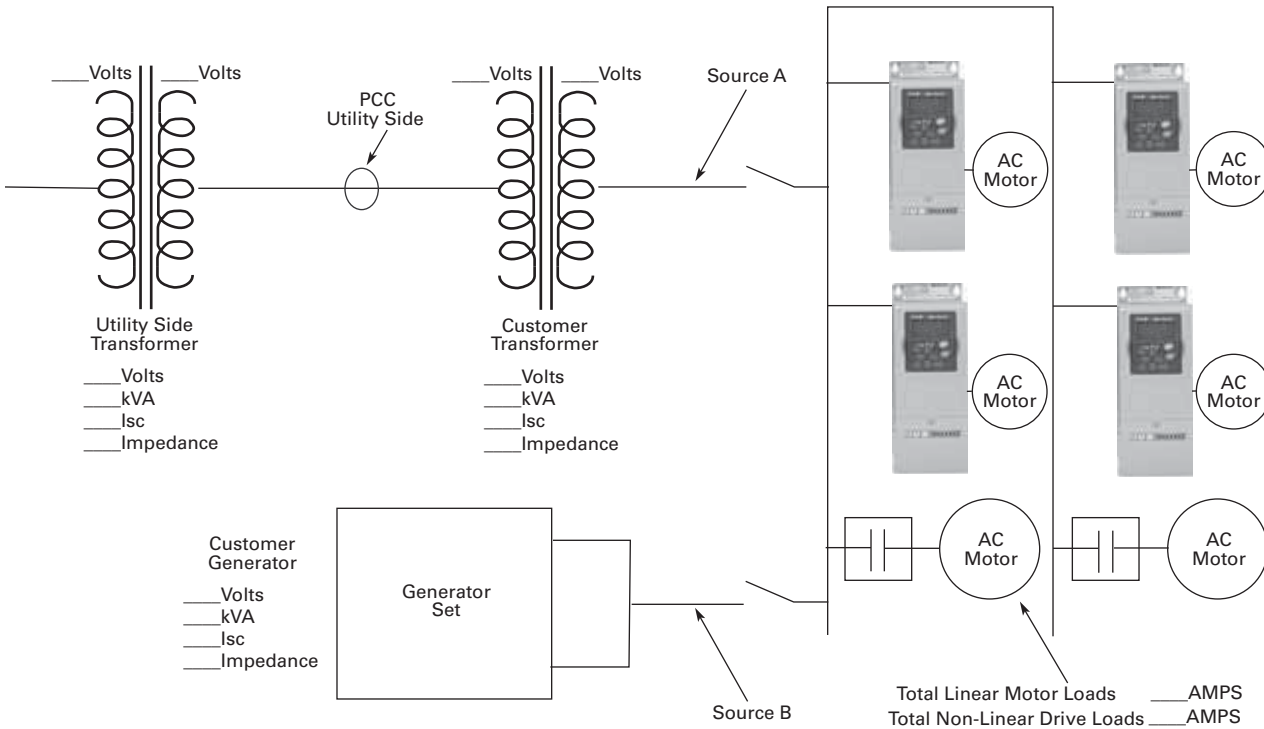

The best way to estimate AFD harmonic contribution to an electrical system is to perform a harmonic analysis based on known system characteristics. The one-line in this figure would provide the data to complete the calculations.

Terms

- PCC (Point of Common Coupling) is defined as the electrical connecting point between the utility and multiple customers per the specifications in IEEE 519
- POA (Point of Analysis) is defined as where the harmonic calculations are taken

An oscilloscope can make all measurements at the PCC or POA do an on-site harmonic evaluation.

Harmonic Reduction Methods to Meet IEEE 519

1. Line Reactor

A line reactor is a three-phase series inductance on the line side of an AFD. If a line reactor is applied on all AFDs, it is possible to meet IEEE guidelines where 10–25% of system loads are AFDs, depending on the stiffness of the line and the value of line reactance. Line reactors are available in various values of impedance, most typically 1–1.5%, 3% and 5%.

Line Reactor

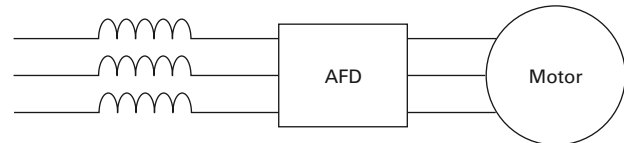

Advantages

- Low cost
- Can provide moderate reduction in voltage and current harmonics
- Available in various values of impedance
- Provides increased input protection for AFD and its semiconductors from line transients

Disadvantages

- May not reduce harmonic levels to below IEEE 519-1992 guidelines
- Voltage drop due to IR loss

2. 12-Pulse Converters

A 12-pulse converter incorporates two separate AFD input semiconductor bridges, which are fed from 30° phase shifted power sources with identical impedance. The sources may be two isolation transformers, where one is a delta/wye design (which provides the phase shift)

and the second a delta/delta design (which does not phase shift). The 12-pulse arrangement allows the harmonics from the first converter to cancel the harmonics of the second. Up to approximately 85% reduction of harmonic current and voltage distortion may be achieved (over standard

six-pulse converter). This permits a facility to use a larger percentage of AFD loads under IEEE 519-1992 guidelines than allowable using line reactors or DC chokes. A harmonic analysis is required to guarantee compliance with guidelines.

Basic 12-Pulse Rectifier with "Phase Shifting" Transformer

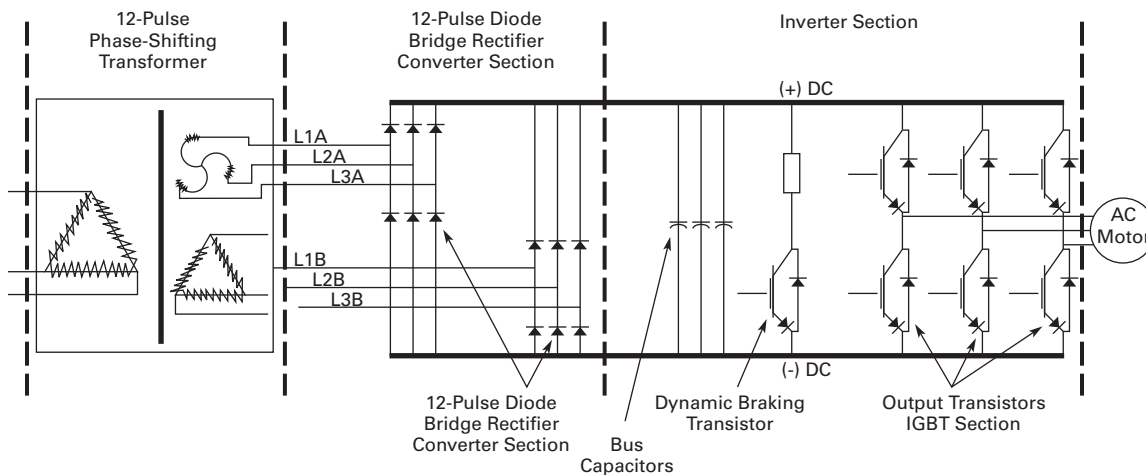

500 hp 480V Drive with 12-Pulse Rectifier

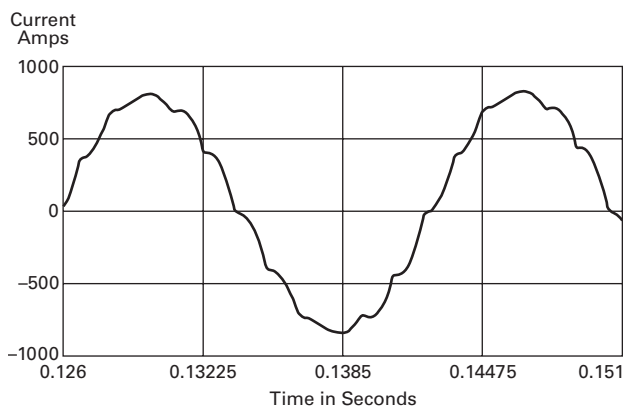

500 hp 480V Drive with 12-Pulse Rectifier

12-Pulse Circuit

Current harmonics

$I_1 = 100\%$	$I_{11} = 4.19\%$	$I_{19} = 0.06\%$
$I_5 = 1.25\%$	$I_{13} = 2.95\%$	$I_{23} = 0.87\%$
$I_7 = 0.48\%$	$I_{17} = 0.21\%$	$I_{25} = 0.73\%$

Power = 500 hp

$H_c = 66.2$ amps

Advantages

- Moderate cost, although significantly more than reactors or chokes
- Substantial reduction (up to approx. 85%) in voltage and current harmonics
- Provides increased input protection for AFD and its semiconductors from line transients

Disadvantages

- Impedance matching of phase shifted sources is critical to performance
- Transformers often require separate mounting or larger AFD enclosures
- May not reduce distribution harmonic levels to below IEEE 519-1992 guidelines
- Cannot retrofit for most AFDs

2.8

Adjustable Frequency Drives

Low Harmonic Drives

2

3. Clean Power Drives

When the total load is of non-linear, the greatest harmonic mitigation is required. Under these conditions, the currents drawn from the supply need to be sinusoidal and “clean” such that system interference and additional losses are negligible. Eaton’s enclosed 18-pulse clean power drive uses a phase-shifting auto-transformer with delta-connected winding. Three of the output phases

are advanced and three are retarded. The remaining three phases of this nine-phase supply are in phase with the incoming line. This results in nine separate phases. In this type of configuration, the total required kVA rating of the transformer is only 48% of a drive rate isolation transformer. A traditional isolated transformer system, with multipulse windings, would require the full kVA

rating to be supported, which is more common in an MV step-down transformer.

The integrated 18-pulse clean power drive, with near sine wave input current and low harmonics will meet the requirements of IEEE 519-1992 under all practical operating conditions. The comparisons with six-pulse and 12-pulse systems are shown, see **Pages V6-T2-235, V6-T2-237 and V6-T2-238.**

Basic 18-Pulse Rectifier with Phase Shifting Transformer

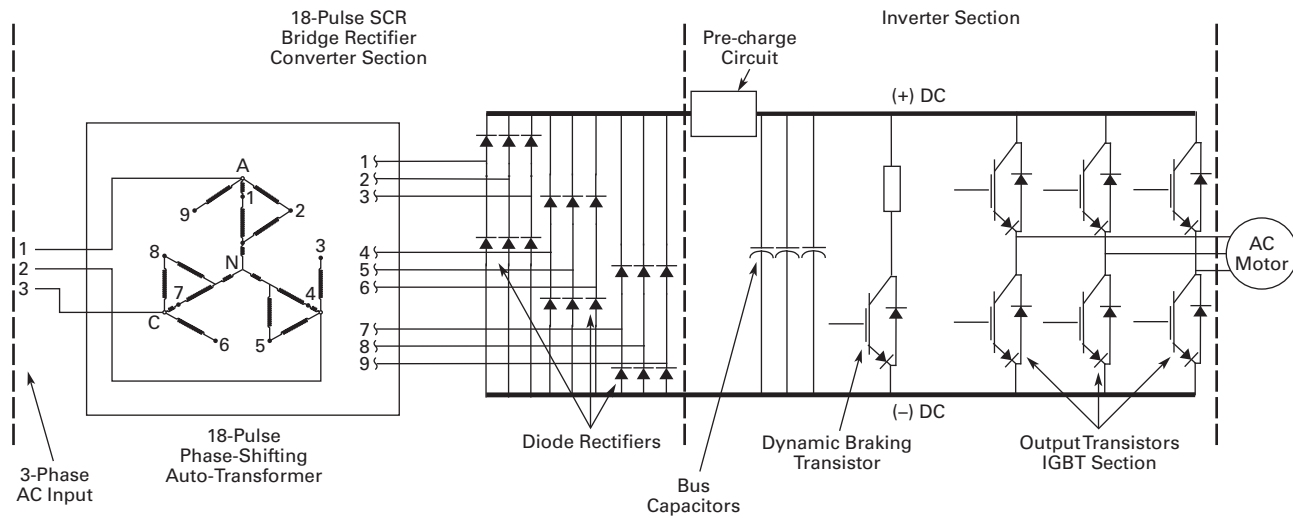

500 hp 480V Drive with 18-Pulse Rectifiers

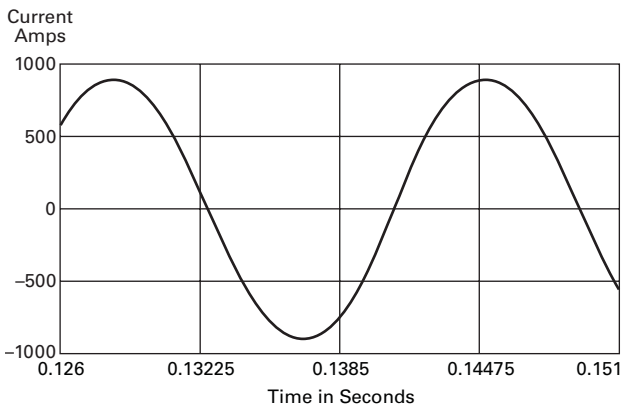

500 hp 480V Drive with 18-Pulse Rectifiers

18-Pulse Clean Power

Current harmonics

$I_1 = 100\%$	$I_{11} = 0.24\%$	$I_{19} = 1.00\%$
$I_5 = 0.16\%$	$I_{13} = 0.10\%$	$I_{23} = 0.01\%$
$I_7 = 0.03\%$	$I_{17} = 0.86\%$	$I_{25} = 0.01\%$

Power = 500 hp

$I_c = 24$ amps

Advantages

- Virtually guarantees compliance with IEEE 519-1992
- Provides increased input protection for AFD and its semiconductors from line transients
- Up to four times the harmonic reduction of 12-pulse methods
- Smaller transformer than isolation transformer used in 12-pulse converter

Disadvantages

- Not as cost-effective as some other methods at small (<50) horsepower

Features and Benefits

Enclosed 18-pulse clean power drive features include:

- Space optimized enclosure
- Simple layout for power options
- Type 1, NEMA 12 with gaskets and filters, Type 3R
- Input voltage: 480V, 208V, 575V
- Complete range of control, network and power options

- Horsepower range:
 - 480V, 25–800 hp (consult factory for larger sizes)
 - 208/230V, 25–200 hp
 - 575V, 25–800 hp (consult factory for larger sizes)
- Over 15 years of 18-pulse clean power experience
- 65 kAIC Standard at 480V and 208V
- 100 kAIC optional

Standards and Certifications

UL 508C tested, listed and approved.

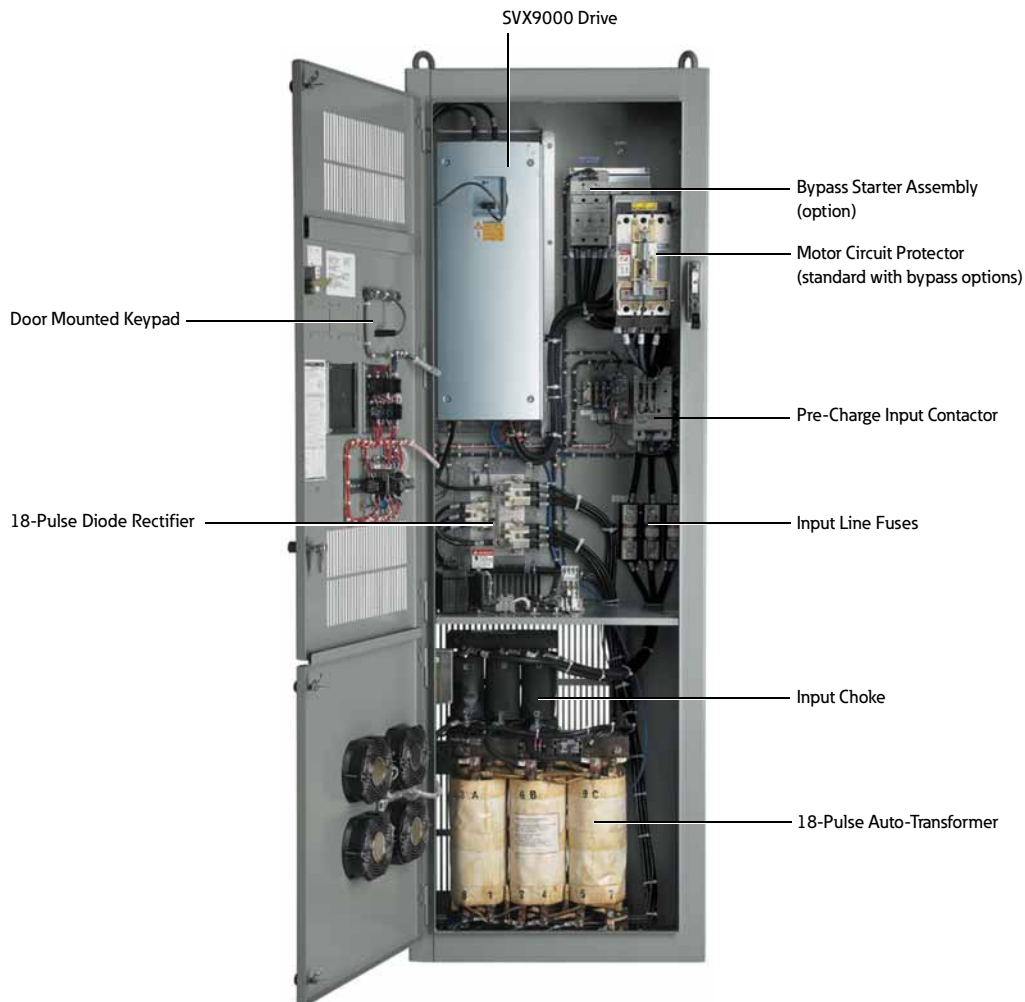
**Product Identification****Type 1, 25–150 hp (30 x 90 x 21.50)**

2.8

Adjustable Frequency Drives

Low Harmonic Drives

Catalog Number Selection

Enclosed 18-Pulse Drive

2

CPX 100 1 4 A A

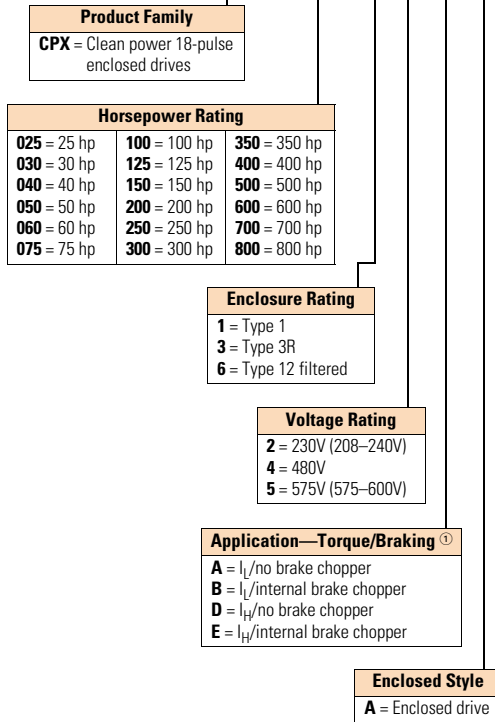

Build options alphabetically and numerically.

Enclosed Options ^{②③④}		Type
K1	Door-mounted speed potentiometer ^⑤	Control
K2	Door-mounted speed potentiometer with HOA selector switch ^⑤	Control
K3	3–15 psig follower	Control
K4	HAND/OFF/AUTO switch 0.87-inch (22 mm)	Control
K5	MANUAL/AUTO reference switch 0.87-inch (22 mm)	Control
K6	START/STOP pushbuttons 0.87-inch (22 mm)	Control
KF	Bypass test switch for RA and RB	Addl. bypass
KO	Standard elapsed time meter	Control
L1	Power, RUN and fault pilot lights	Light
L2	Bypass pilot lights for RA, RB, bypass options	Addl. bypass
LE	Red RUN light	Light
P1	Input disconnect	Input
P8	Surge protective device	Input
PE	Output contactor	Output
PF	Output filter	Output
PG	MotoRx (up to 600 ft [182.9m]) 1000 V/μS DV/DT filter	Output
PH	Single overload relay	Output
PI	Dual overload relays	Output
PN	Dual overloads for bypass	Addl. bypass
RA	Manual HOA bypass controller	Bypass
RB	Manual IOB bypass controller	Bypass
RC	Auto transfer HOA bypass controller	Bypass
RD	Auto transfer IOB bypass controller	Bypass
RG	Reduced voltage starter for bypass	Bypass
S7	10.00-inch (254.0 mm) expansion	Enclosure
S8	20.00-inch (508.0 mm) expansion	Enclosure
S9	Space heater	Enclosure

Communication Options ^⑥	
C2 = Modbus [®]	CA = Johnson Controls N2
C3 = PROFIBUS [®] DP	CI = Modbus TCP
C4 = LonWorks [®]	CJ = BACnet
C5 = PROFIBUS DP (D9 connector)	CQ = EtherNet/IP
C6 = CANopen (slave)	D3 = RS-232 with D9 connection
C7 = DeviceNet [™]	
C8 = Modbus (D9 Type connector)	

Control Options
B1 = 6 DI, 1 ext +24 Vdc/ext +24 Vdc
B2 = 1 RO (NC/NO), 1 RO (NO), 1 therm
B4 = 1 AI (mA isolated), 2 AO (mA isolated), 1 ext +24 Vdc/EXT +24 Vdc
B5 = 3 RO (NO)
B8 = 1 ext +24 Vdc/ext +24 Vdc, 3 Pt100
B9 = 1 RO (NO), 5 DI 42–240 Vac input

Engineered Options	
HT	High temperature rating for 50°C (FR10 and above) ^⑦
VB	Varnished boards

Notes

- ① Brake chopper is standard in drives up to 30 hp I_H or 40 hp I_L at 480V. It is optional in larger drives.
- ② Local/remote keypad is included as the standard control panel.
- ③ Some options are voltage and/or horsepower specific. Consult your Eaton representative for details.
- ④ See **Pages V6-T2-251** and **V6-T2-252** for complete descriptions.
- ⑤ Includes local/remote speed reference switch.
- ⑥ See **Pages V6-T2-249** and **V6-T2-250** for complete descriptions.
- ⑦ Consult Eaton for availability.

Product Selection

When Ordering

- Select a base catalog number that meets the application requirements—nominal horsepower, voltage and enclosure rating. (The enclosed drive's continuous output amp rating should be equal to or greater than the motor's full load amp rating.) The base-enclosed package includes a standard drive, door-mounted alphanumeric panel and enclosure.
- The enclosed 18-pulse drive product uses the term High Overload (I_H) in place of the term Constant Torque (CT). Likewise, Low Overload (I_L) is used in place of the term Variable Torque (VT). The new terms are a more precise description of the rating. The older terms included ambient temperature ratings in addition to overload ratings. In order to minimize enclosure size and offer the highest ambient temperature rating, overload and temperature ratings are now treated separately. Ambient temperature ratings are shown in the table below. Consult the factory for 50°C ratings of FR10 and above.
- If dynamic brake chopper or control/communication option is desired, change the appropriate code in the base catalog number.
- All of the programming is exactly the same as the standard SVX9000 drive.
- Select enclosed options. Add the codes as suffixes to the base catalog number in alphabetical and numeric order.

Ambient Temperature Ratings

Frame Size	I_H	I_L
FR4–FR9	50°C	50°C
FR10 and above	40°C	40°C

208/230V Drives

Enclosed 18-Pulse Drive



Enclosed 18-Pulse Base Drive Type 1

Enclosure Size ①	hp ②	Current (A)	Chassis Frame	Base Catalog Number ③
Low Overload Drive				
7	25	75	FR7	CPX02512AA
	30	88	FR7	CPX03012AA
	40	114	FR7	CPX04012AA
	50	140	FR8	CPX05012AA
	60	170	FR8	CPX06012AA
	75	205	FR8	CPX07512AA
8	100	300	FR9	CPX10012AA
9	125	340	FR8T	CPX12512AA
	150	410	FR8T	CPX15012AA
10	200	522	FR9T	CPX20012AA
High Overload Drive				
7	25	75	FR7	CPX02512DA
	30	88	FR7	CPX03012DA
	40	114	FR8	CPX04012DA
	50	140	FR8	CPX05012DA
	60	170	FR8	CPX06012DA
8	75	205	FR9	CPX07512DA
9	100	300	FR8T	CPX10012DA
	125	340	FR8T	CPX12512DA
10	150	410	FR9T	CPX15012DA
	200	522	FR9T	CPX20012DA

Notes

- ① See enclosure dimensions beginning on [Page V6-T2-258](#).
 ② hp ratings are provided as a guideline. Drives should be sized per motor nameplate FLA.
 ③ The 18-pulse clean power assembly includes a standard drive, door-mounted local/remote keypad and enclosure.

Enclosed 18-Pulse Drive



Enclosed 18-Pulse Base Drive NEMA 12 Filtered

Enclosure Size ^①	hp ^②	Current (A)	Chassis Frame	Base Catalog Number ^③
Low Overload Drive				
7	25	75	FR7	CPX02562AA
	30	88	FR7	CPX03062AA
	40	114	FR7	CPX04062AA
	50	140	FR8	CPX05062AA
	60	170	FR8	CPX06062AA
	75	205	FR8	CPX07562AA
8	100	300	FR9	CPX10062AA
9	125	340	FR8T	CPX12562AA
	150	410	FR8T	CPX15052AA
10	200	522	FR9T	CPX20062AA
High Overload Drive				
7	25	75	FR7	CPX02562DA
	30	88	FR7	CPX03062DA
	40	114	FR8	CPX04062DA
	50	140	FR8	CPX05062DA
	60	170	FR8	CPX06062DA
	75	205	FR8	CPX07562DA
8	100	300	FR9	CPX10062DA
9	125	340	FR8T	CPX12562DA
	150	410	FR8T	CPX15062DA
10	200	522	FR9T	CPX20062DA

Enclosed 18-Pulse Base Drive Type 3R ^④

Enclosure Size ^①	hp ^②	Current (A)	Chassis Frame	Base Catalog Number ^③
Low Overload Drive				
7	25	75	FR7	CPX02532AA
	30	88	FR7	CPX03032AA
	40	114	FR7	CPX04032AA
	50	140	FR8	CPX05032AA
	60	170	FR8	CPX06032AA
	75	205	FR8	CPX07532AA
8	100	300	FR9	CPX10032AA
9	125	340	FR8T	CPX12532AA
High Overload Drive				
7	25	75	FR7	CPX02532DA
	30	88	FR7	CPX03032DA
	40	114	FR8	CPX04032DA
	50	140	FR8	CPX05032DA
	60	170	FR8	CPX06032DA
	75	205	FR8	CPX07532DA
8	100	300	FR9	CPX10032DA
9	125	340	FR8T	CPX12532DA

Notes

- ① See enclosure dimensions beginning on **Page V6-T2-258**.
- ② hp ratings are provided as a guideline. Drives should be sized per motor nameplate FLA.
- ③ The 18-pulse clean power assembly includes a standard drive, door-mounted local/remote keypad and enclosure.
- ④ All Type 3R drives use the Size F enclosure.

480V Drives

Enclosed 18-Pulse Drive



Enclosed 18-Pulse Base Drive Type 1

Enclosure Size ^①	hp ^②	Current (A)	Chassis Frame	Base Catalog Number ^③
Low Overload Drive				
7	25	38	FR6	CPX02514BA
	30	46	FR6	CPX03014BA
	40	61	FR6	CPX04014BA
	50	72	FR7	CPX05014AA
	60	87	FR7	CPX06014AA
	75	105	FR7	CPX07514AA
	100	140	FR8	CPX10014AA
	125	170	FR8	CPX12514AA
	150	205	FR8	CPX15014AA
8	200	261	FR9	CPX20014AA
	250	300	FR9	CPX25014AA
9	300	385	FR10	CPX30014AA
	350	460	FR10	CPX35014AA
	400	520	FR10	CPX40014AA
10	500	590	FR11	CPX50014AA
	550	650	FR11	CPX55014AA
	600	730	FR11	CPX60014AA
11	650	820	FR11	CPX65014AA
	700	920	FR12	CPX70014AA
	800	1030	FR12	CPX80014AA
High Overload Drive				
7	25	38	FR6	CPX02514EA
	30	46	FR6	CPX03014EA
	40	61	FR7	CPX04014DA
	50	72	FR7	CPX05014DA
	60	87	FR7	CPX06014DA
	75	105	FR8	CPX07514DA
	100	140	FR8	CPX10014DA
	125	170	FR8	CPX12514DA
	8	150	205	FR9
200		245	FR9	CPX20014DA
9	250	300	FR10	CPX25014DA
	300	385	FR10	CPX30014DA
	350	460	FR10	CPX35014DA
10	400	520	FR11	CPX40014DA
	500	590	FR11	CPX50014DA
	550	650	FR11	CPX55014DA
11	600	720	FR12	CPX60014DA
	650	820	FR12	CPX65014DA
	700	840	FR12	CPX70014DA

Notes

① See enclosure dimensions beginning on **Page V6-T2-258**.

② hp ratings are provided as a guideline. Drives should be sized per motor nameplate FLA.

③ The 18-pulse clean power assembly includes a standard drive, door-mounted local/remote keypad and enclosure.

Enclosed 18-Pulse Drive



2

Enclosed 18-Pulse Base Drive NEMA 12 Filtered

Enclosure Size ^①	hp ^②	Current (A)	Chassis Frame	Base Catalog Number ^③
Low Overload Drive				
7	25	38	FR6	CPX02564BA
	30	46	FR6	CPX03064BA
	40	61	FR6	CPX04064BA
	50	72	FR7	CPX05064AA
	60	87	FR7	CPX06064AA
	75	105	FR7	CPX07564AA
	100	140	FR8	CPX10064AA
	125	170	FR8	CPX12564AA
8	150	205	FR8	CPX15064AA
	200	261	FR9	CPX20064AA
8	250	300	FR9	CPX25064AA
	300	385	FR10	CPX30064AA
9	350	460	FR10	CPX35064AA
	400	520	FR10	CPX40064AA
10	500	590	FR11	CPX50064AA
	550	650	FR11	CPX55064AA
	600	730	FR11	CPX60064AA
11	650	820	FR11	CPX65064AA
	700	920	FR12	CPX70064AA
	800	1030	FR12	CPX80064AA
High Overload Drive				
7	25	38	FR6	CPX02564EA
	30	46	FR6	CPX03064EA
	40	61	FR7	CPX04064DA
	50	72	FR7	CPX05064DA
	60	87	FR7	CPX06064DA
	75	105	FR8	CPX07564DA
	100	140	FR8	CPX10064DA
	125	170	FR8	CPX12564DA
8	150	205	FR9	CPX15064DA
	200	245	FR9	CPX20064DA
9	250	300	FR10	CPX25064DA
	300	385	FR10	CPX30064DA
	350	460	FR10	CPX35014DA
10	400	520	FR11	CPX40064DA
	500	590	FR11	CPX50064DA
	550	650	FR11	CPX55064DA
11	600	720	FR12	CPX60064DA
	650	820	FR12	CPX65064DA
	700	840	FR12	CPX70064DA

Notes

- ① See enclosure dimensions beginning on [Page V6-T2-258](#).
 ② hp ratings are provided as a guideline. Drives should be sized per motor nameplate FLA.
 ③ The 18-pulse clean power assembly includes a standard drive, door-mounted local/remote keypad and enclosure.

Enclosed 18-Pulse Drive



Enclosed 18-Pulse Base Drive Type 3R ①

Enclosure Size ②	hp ③	Current (A)	Chassis Frame	Base Catalog Number ④
Low Overload Drive				
7	25	38	FR6	CPX02534AA
	30	46	FR6	CPX03034AA
	40	61	FR6	CPX04034AA
	50	72	FR7	CPX05034AA
	60	87	FR7	CPX06034AA
	75	105	FR7	CPX07534AA
	100	140	FR8	CPX10034AA
	125	170	FR8	CPX12534AA
	150	205	FR8	CPX15034AA
8	200	261	FR9	CPX20034AA
	250	300	FR9	CPX25034AA
High Overload Drive				
7	25	38	FR6	CPX02534DA
	30	46	FR6	CPX03034DA
	40	61	FR7	CPX04034DA
	50	72	FR7	CPX05034DA
	60	87	FR7	CPX06034DA
	75	105	FR8	CPX07534DA
	100	140	FR8	CPX10034DA
	125	170	FR8	CPX12534DA
	8	150	205	FR9
200		245	FR9	CPX20034DA

Notes

- ① All Type 3R drives use the Size F enclosure.
- ② See enclosure dimensions beginning on **Page V6-T2-258**.
- ③ hp ratings are provided as a guideline. Drives should be sized per motor nameplate FLA.
- ④ The 18-pulse clean power assembly includes a standard drive, door-mounted local/remote keypad and enclosure.

575V Drives

2

Enclosed 18-Pulse Drive



Enclosed 18-Pulse Base Drive Type 1

Enclosure Size ^①	hp ^②	Current (A)	Chassis Frame	Base Catalog Number ^③
Low Overload Drive				
7	25	27	FR6	CPX02515AA
	30	34	FR6	CPX03015AA
	40	41	FR7	CPX04015AA
	50	52	FR7	CPX05015AA
	60	62	FR8	CPX06015AA
	75	80	FR8	CPX07515AA
	100	100	FR8	CPX10015AA
8	125	125	FR9	CPX12515AA
	150	144	FR9	CPX15015AA
	200	208	FR9	CPX20015AA
9	250	261	FR10	CPX25015AA
	300	325	FR10	CPX30015AA
	400	385	FR10	CPX40015AA
10	500	502	FR11	CPX50015AA
	600	590	FR11	CPX60015AA
11	650	650	FR12	CPX65015AA
	700	750	FR12	CPX70015AA
	800	820	FR12	CPX80015AA
High Overload Drive				
7	25	27	FR6	CPX02515DA
	30	34	FR7	CPX03015DA
	40	41	FR7	CPX04015DA
	50	52	FR8	CPX05015DA
	60	62	FR8	CPX06015DA
	75	80	FR8	CPX07515DA
	100	100	FR9	CPX10015DA
8	125	125	FR9	CPX12515DA
	150	144	FR9	CPX15015DA
	200	208	FR10	CPX20015DA
9	250	261	FR10	CPX25015DA
	300	325	FR10	CPX30015DA
	400	385	FR11	CPX40015DA
10	450	460	FR11	CPX45015DA
	500	502	FR11	CPX50015DA
	600	590	FR12	CPX60015DA
11	650	650	FR12	CPX65015DA
	700	750	FR12	CPX70015DA

Notes

- ① See enclosure dimensions beginning on **Page V6-T2-258**.
- ② hp ratings are provided as a guideline. Drives should be sized per motor nameplate FLA.
- ③ The 18-pulse clean power assembly includes a standard drive, door-mounted local/remote keypad and enclosure.

Enclosed 18-Pulse Drive



Enclosed 18-Pulse Base Drive NEMA 12 Filtered

Enclosure Size ^①	hp ^②	Current (A)	Chassis Frame	Base Catalog Number ^③
Low Overload Drive				
7	25	27	FR6	CPX02565AA
	30	34	FR6	CPX03065AA
	40	41	FR7	CPX04065AA
	50	52	FR7	CPX05065AA
	60	62	FR8	CPX06065AA
	75	80	FR8	CPX07565AA
	100	100	FR8	CPX10065AA
8	125	125	FR9	CPX12565AA
	150	144	FR9	CPX15065AA
	200	208	FR9	CPX20065AA
9	250	261	FR10	CPX25065AA
	300	325	FR10	CPX30065AA
	400	385	FR10	CPX40065AA
10	500	502	FR11	CPX50065AA
	600	590	FR11	CPX60065AA
11	650	650	FR12	CPX65065AA
	700	750	FR12	CPX70065AA
	800	820	FR12	CPX80065AA
High Overload Drive				
7	25	27	FR6	CPX02565DA
	30	34	FR7	CPX03065DA
	40	41	FR7	CPX04065DA
	50	52	FR8	CPX05065DA
	60	62	FR8	CPX06065DA
	75	80	FR8	CPX07565DA
	8	100	100	FR9
125		125	FR9	CPX12565DA
150		144	FR9	CPX15065DA
9	200	208	FR10	CPX20065DA
	250	261	FR10	CPX25065DA
	300	325	FR10	CPX30065DA
10	400	385	FR11	CPX40065DA
	450	460	FR11	CPX45065DA
	500	502	FR11	CPX50065DA
11	600	590	FR12	CPX60065DA
	650	650	FR12	CPX65065DA
	700	750	FR12	CPX70065DA

Notes

① See enclosure dimensions beginning on **Page V6-T2-258**.

② hp ratings are provided as a guideline. Drives should be sized per motor nameplate FLA.

③ The 18-pulse clean power assembly includes a standard drive, door-mounted local/remote keypad and enclosure.

Enclosed 18-Pulse Drive



Enclosed 18-Pulse Base Drive Type 3R ①

Enclosure Size ②	hp ③	Current (A)	Chassis Frame	Base Catalog Number ④
Low Overload Drive				
7	25	27	FR6	CPX02535AA
	30	34	FR6	CPX03035AA
	40	41	FR7	CPX04035AA
	50	52	FR7	CPX05035AA
	60	62	FR8	CPX06035AA
	75	80	FR8	CPX07535AA
	100	100	FR8	CPX10035AA
8	125	125	FR9	CPX12535AA
	150	144	FR9	CPX15035AA
	200	208	FR9	CPX20035AA
High Overload Drive				
7	25	27	FR6	CPX02535DA
	30	34	FR7	CPX03035DA
	40	41	FR7	CPX04035DA
	50	52	FR8	CPX05035DA
	60	62	FR8	CPX06035DA
	75	80	FR8	CPX07535DA
8	100	100	FR9	CPX10035DA
	125	125	FR9	CPX12535DA
	150	144	FR9	CPX15035DA

Notes

- ① All Type 3R drives use the Size F enclosure.
- ② See enclosure dimensions beginning on **Page V6-T2-258**.
- ③ hp ratings are provided as a guideline. Drives should be sized per motor nameplate FLA.
- ④ The 18-pulse clean power assembly includes a standard drive, door-mounted local/remote keypad and enclosure.

Options

Enclosed 18-Pulse Drive Option Board Kits

The enclosed 18-pulse drives can accommodate a wide selection of expander and adapter option boards to customize the drive for your application needs. The drive's control unit is designed to accept a total of five option boards (see figure below).

The enclosed 18-pulse drives factory-installed standard board configuration includes an A9 I/O board and an A2 relay output board, which are installed in slots A and B.

9000X Series Option Board Kits

Option Boards

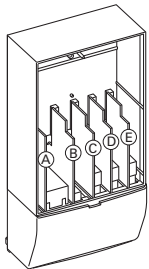

Option Board Kits

Option Kit Description ^①	Allowed Slot Locations ^②	Field Installed Catalog Number	Factory Installed Option Designator	SVX Ready Programs						
				Basic	Local/Remote	Standard	MSS	PID	Multi-P.	PFC
Standard I/O Cards										
2 RO (NC/NO)	B	OPTA2	—	■	■	■	■	■	■	■
6 DI, 1 DO, 2 AI, 1AO, 1 +10 Vdc ref, 2 ext +24 Vdc/ext +24 Vdc	A	OPTA9	—	■	■	■	■	■	■	■
Extended I/O Cards										
6 DI	B, C, D , E	OPTB1	B1	—	—	—	—	—	■	■
1 RO (NC/NO), 1 RO (NO), 1 therm	B, C, D , E	OPTB2	B2	—	—	—	—	—	■	■
1 AI (mA isolated), 2 AO (mA isolated)	B, C, D , E	OPTB4	B4	■	■	■	■	■	■	■
3 RO (NO)	B, C, D , E	OPTB5	B5	—	—	—	—	—	■	■
3 Pt100 RTD board	B, C, D , E	OPTB8	B8	—	—	—	—	—	■	—
1 RO (NO), 5 DI 42–240 Vac input	B, C, D , E	OPTB9	B9	—	—	—	—	—	■	■
Communication Cards ^③										
Modbus	D, E	OPTC2	C2	■	■	■	■	■	■	■
Modbus TCP	D, E	OPTCI	CI	■	■	■	■	■	■	■
BACnet	D, E	OPTCJ	CJ	■	■	■	■	■	■	■
EtherNet/IP	D, E	OPTCQ	CQ	■	■	■	■	■	■	■
Johnson Controls N2	D, E	OPTC2	CA	■	■	■	■	■	■	■
PROFIBUS DP	D, E	OPTC3	C3	■	■	■	■	■	■	■
LonWorks	D, E	OPTC4	C4	■	■	■	■	■	■	■
PROFIBUS DP (D9 connector)	D, E	OPTC5	C5	■	■	■	■	■	■	■
CANopen (slave)	D, E	OPTC6	C6	■	■	■	■	■	■	■
DeviceNet	D, E	OPTC7	C7	■	■	■	■	■	■	■
Modbus (D9 type connector)	D, E	OPTC8	C8	■	■	■	■	■	■	■
RS-232 with D9 connection	D, E	OPTD3	D3	■	■	■	■	■	■	■

Notes

① AI = Analog Input; AO = Analog Output, DI = Digital Input, DO = Digital Output, RO = Relay Output

② Option card must be installed in one of the slots listed for that card. Slot indicated in bold is the preferred location.

③ OPTC2 is a multi-protocol option card.

Modbus RTU Network Communications

The Modbus Network Card OPTC2 is used for connecting the 9000X Drive as a slave on a Modbus network. The interface is connected by a 9-pin DSUB connector (female) and the baud rate ranges from 300 to 19,200 baud. Other communication parameters include an address range from 1 to 247; a parity of None, Odd or Even; and the stop bit is 1.

PROFIBUS Network Communications

The PROFIBUS Network Card OPTC3 is used for connecting the 9000X Drive as a slave on a PROFIBUS-DP network. The interface is connected by a 9-pin DSUB connector (female). The baud rates range from 9.6K baud to 12M baud, and the addresses range from 1 to 127.

LonWorks Network Communications

The LonWorks Network Card OPTC4 is used for connecting the 9000X Drive on a LonWorks network. This interface uses Standard Network Variable Types (SNVT) as data types. The channel connection is achieved using a FTT-10A Free Topology transceiver via a single twisted transfer cable. The communication speed with LonWorks is 78 kBits/s.

CANopen (Slave) Communications

The CANopen (Slave) Network Card OPTC6 is used for connecting the 9000X Drive to a host system. According to ISO[®] 11898 standard cables to be chosen for CAN bus should have a nominal impedance of 120 ohms, and specific line delay of nominal 5 nS/m. 120 ohm line termination resistors required for installation.

DeviceNet Network Communications

The DeviceNet Network Card OPTC7 is used for connecting the 9000X Drive on a DeviceNet Network. It includes a 5.08 mm pluggable connector. Transfer method is via CAN using a two-wire twisted shielded cable with two-wire bus power cable and drain. The baud rates used for communication include 125K baud, 250K baud and 500K baud.

Johnson Controls Metasys N2 Network Communications

The OPTC2 fieldbus board provides communication between the 9000X Drive and a Johnson Controls Metasys™ N2 network. With this connection, the drive can be controlled, monitored and programmed from the Metasys system. The N2 fieldbus is available as a factory-installed option and as a field-installable kit.

Modbus/TCP Network Communications

The Modbus/TCP Network Card OPTCI is used for connecting the 9000X Drive to Ethernet networks using Modbus protocol. It includes an RJ-45 pluggable connector. This interface provides a selection of standard and custom register values to communicate drive parameters. The board supports 10 Mbps and 100 Mbps communication speeds. The IP address of the board is configurable over Ethernet using a supplied software tool.

BACnet Network Communications

The BACnet Network Card OPTCJ is used for connecting the 9000X Drive to BACnet networks. It includes a 5.08 mm pluggable connector. Data transfer is Master-Slave/Token Passing (MS/TP) RS-485. This interface uses a collection of 30 Binary Value Objects (BVOs) and 35 Analog Value Objects (AVOs) to communicate drive parameters. The card supports 9.6, 19.2 and 38.4 Kbaud communication speeds and supports network addresses 1 to 127.

Ethernet/IP Network Communications

The Ethernet/IP Network Card OPTCK is used for connecting the 9000X Drive to Ethernet/Industrial Protocol networks. It includes an RJ-45 pluggable connector. The interface uses CIP objects to communicate drive parameters (CIP is "Common Industrial Protocol," the same protocol used by DeviceNet). The board supports 10 Mbps and 100 Mbps communication speeds. The IP address of the board is configurable by Static, BOOTP and DHCP methods.

Control/Communication Option Descriptions

For availability, see Product Selection for base drive voltage required.

Available Control/Communications Options

Option	Description	Option Type
K1	Door-Mounted Speed Potentiometer —Provides the enclosed 18-pulse drive with the ability to adjust the frequency reference using a door-mounted potentiometer. This option uses the 10 Vdc reference to generate a 0–10V signal at the analog voltage input signal terminal. When the HOA bypass option is added, the speed is controlled when the HOA switch is in the HAND position. Without the HOA bypass option, a two-position switch (labeled local/remote) is provided on the keypad to select speed reference from the speed potentiometer or a remote speed signal.	Control
K2	Door-Mounted Speed Potentiometer with HOA Selector Switch —Provides the enclosed 18-pulse drive with the ability to start/stop and adjust the speed reference from door-mounted control devices or remotely from customer-supplied inputs. In HAND position, the drive will start and the speed is controlled by the door-mounted speed potentiometer. The drive will be disabled in the OFF position. When AUTO is selected, the drive run and speed control commands are via user-supplied dry contact and 4–20 mA signal.	Control
K3	3–15 psig Follower —Provides a pneumatic transducer that converts a 3–15 psig pneumatic signal to either 0–8 Vdc or a 1–9 Vdc signal interface with the enclosed 18-pulse drive. The circuit board is mounted on the inside of the front enclosure panel and connects to the user's pneumatic control system via 6 ft (1.8m) of flexible tubing and a 1/4 inch (6.4 mm) brass tube union.	Control
K4	HAND/OFF/AUTO Switch for Non-Bypass Configurations —Provides a three-position selector switch that allows the user to select either a HAND or AUTO mode of operation. HAND mode is defaulted to keypad operation, and AUTO mode is defaulted to control from an external terminal source. These modes of operation can be configured via drive programming to allow for alternate combinations of start and speed sources. Start and speed sources include Keypad, I/O and fieldbus.	Control
K5	MANUAL/AUTO Speed Reference Switch —Provides door-mounted selector switch for MANUAL/AUTO speed reference.	Control
K6	START/STOP Pushbuttons —Provide door-mounted START and STOP pushbuttons for either bypass or non-bypass configurations.	Control
KF	Bypass Test Switch for RB and RA —Allows the user to energize the AF drive for testing while operating the motor on the bypass controller. The Test Switch is mounted on the inside of the enclosure door.	Addl. bypass
K0	Standard Elapsed Time Meter —Provides a door-mounted elapsed run-time meter.	Control
L1	Power On and Fault Power Lights —Provide a white Power On light that indicates power to the enclosed cabinet and a red fault light that indicates a drive fault has occurred.	Light
L2	Bypass Pilot Lights for RB, RA Bypass Options —A green light indicates when the motor is running in Inverter mode and an amber light indicates when the motor is running in Bypass mode. The lights are mounted on the enclosure door, above the switches.	Addl. bypass
LE	Red Run Pilot Light 0.87-Inch (22 mm) —Provides a red Run pilot light that indicates the drive is running.	Light
P1	Input Circuit Breaker —High interrupting circuit breaker that provides a means of short-circuit protection for the power cables between it and the enclosed 18-pulse drive, and protection from high-level ground faults on the power cable. Allows a convenient means of disconnecting the enclosed 18-pulse drive from the line and the operating mechanism can be padlocked in the OFF position. This is factory mounted in the enclosure. Standard rating is 65 kAIC at 208/480V. 100 kAIC is available as an option.	Input
PE	Output Contactor —Provides a means for positive disconnection of the drive output from the motor terminals. The contactor coil is controlled by the drive's run or permissive logic. NC and NO auxiliary contacts rated at 10A, 600 Vac are provided for customer use. Bypass options RB and RA include an output contactor as standard. This option includes a low VA 115 Vac fused control power transformer and is factory mounted in the enclosure.	Output
PF	Output Filter —Used to reduce the transient voltage (DV/DT) at the motor terminals. The output filter is recommended for cable lengths exceeding 100 ft (30.5m) with a drive of 3 hp and above, for cable lengths of 33 ft (10.1m) with a drive of 2 hp and below, or for a drive rated at 525–690V. This option is mounted in the enclosure.	Output
PG	MotoRx (300–600 Ft) 1000 V/μS DV/DT Filter —Used to reduce transient voltage (DV/DT) and peak voltages at the motor terminals. This option is comprised of a 0.5% line reactor, followed by capacitive filtering and an energy recovery/clamping circuit. Unlike the output filter (see option PF), the MotoRx recovers most of the energy from the voltage peaks, resulting in a lower voltage drop to the motor, and therefore conserving power. This option is used when the distance between a single motor and the drive is 300–600 ft (91.4–182.9m).	Output
PH	Single Overload Relay —Uses a bimetallic overload relay to provide additional overload current protection to the motor on configurations without bypass options. It is included with the bypass configurations for overload current protection in the bypass mode. The overload relay is mounted within the enclosure, and is manually resettable. Heater pack included.	Output
PI	Dual Overload Relays —This option is recommended when a single drive is operating two motors and overload current protection is needed for each of the motors. The standard configuration includes two bimetallic overload relays, each sized to protect a motor with 50% of the drive hp rating. For example, a 100 hp drive would include two overload relays sized to protect two 50 hp motors. The relays are mounted within the enclosure, and are manually resettable. Heater packs not included.	Output
PN	Dual Overloads for Bypass —This option is recommended when a single drive is operating two motors in the Bypass mode and overload current protection is needed for each of the motors. The standard configuration includes two bimetallic overload relays, each sized to protect a motor with 50% of the drive hp rating. For example, a 100 hp drive would include two overload relays sized to protect two 50 hp motors. The relays are mounted within the enclosure, and are manually resettable.	Addl. bypass

For availability, see Product Selection for base drive voltage required.

2 Available Control/Communications Options, continued

Option	Description	Option Type
RA	Manual HOA Bypass Controller —The manual HAND/OFF/AUTO (HOA)—three-contactor—bypass option provides a means of bypassing the enclosed 18-pulse drive, allowing the AC motor to be operated at full speed directly from the AC supply line. This option consists of an input HMCP, a fused control power transformer, and a full voltage bypass starter with a door-mounted HOA selector switch and an INVERTER/BYPASS switch. The HOA switch provides the ability to start and stop the drive in the inverter mode. IEC type input, bypass and input contactors are provided. The contactors are mechanically and electrically interlocked (see wiring diagram on Page V6-T2-257).	Bypass
RB	Manual IOB Bypass Controller —The manual INVERTER/OFF/BYPASS (IOB)—three-contactor—bypass option provides a means of bypassing the enclosed 18-pulse drive, allowing the AC motor to be operated at full speed directly from the AC supply line. This option consists of an input HMCP, a fused control power transformer, and a full voltage bypass starter with a door-mounted IOB selector switch. IEC type input, bypass and input contactors are provided. The contactors are mechanically and electrically interlocked (see wiring diagram on Page V6-T2-257).	Bypass
RC	Auto Transfer HOA Bypass Controller —The manual HAND/OFF/AUTO (HOA)—three-contactor—bypass option provides a means of bypassing the enclosed 18-pulse drive, allowing the AC motor to be operated at full speed directly from the AC supply line. The circuitry provides an automatic transfer of the load to “across the line” operation after a drive trip. This option consists of an input HMCP, a fused control power transformer, and a full voltage bypass starter with a door-mounted HOA selector switch and an INVERTER/BYPASS switch. The HOA switch provides the ability to start and stop the drive in either mode. IEC type input, bypass and input contactors are provided. The contactors are mechanically and electrically interlocked (see wiring diagram on Page V6-T2-257). Door-mounted pilot lights are provided that indicate bypass or inverter operation. A green light indicates when the motor is running in inverter mode and an amber light indicates when the motor is running in bypass mode. WARNING: The motor may restart when the overcurrent relay is reset when operating in bypass, unless the IOB selector switch is turned to the OFF position.	Bypass
RD	Auto Transfer IOB Bypass Controller —The auto INVERTER/OFF/BYPASS (IOB)—three-contactor—bypass option provides a means of bypassing the enclosed 18-pulse drive, allowing the AC motor to be operated at full speed directly from the AC supply line. The circuitry provides an automatic transfer of the load to “across the line” operation after a drive trip. This option consists of an input HMCP, a fused control power transformer, and a full voltage bypass starter with a door-mounted IOB selector switch. IEC type input, bypass and input contactors are provided. The contactors are mechanically and electrically interlocked (see wiring diagram on Page V6-T2-257). Door-mounted pilot lights are provided that indicate bypass or inverter operation. A green light indicates when the motor is running in inverter mode and an amber light indicates when the motor is running in bypass mode. WARNING: The motor may restart when the overcurrent relay is reset when operating in bypass, unless the IOB selector switch is turned to the OFF position.	Bypass
RG	Reduced Voltage Starter for Bypass —Used in conjunction with bypass option RA, RB, RC or RD. This option adds reduced voltage soft starter to bypass assembly for soft starting in bypass mode.	Bypass
S7	10.00-Inch (254.0 mm) Expansion —Expansion cabinet allows for special components, customer-supplied components or oversized cables. NOTE: Enclosure expansion rated Type 1 only.	Enclosure
S8	20.00-Inch (508.0 mm) Expansion —Expansion cabinet allows for special components, customer-supplied components or oversized cables. NOTE: Enclosure expansion rated Type 1 only.	Enclosure
S9	Space Heater —Prevents condensation from forming in the enclosure when the drive is inactive or in storage. Includes a thermostat for variable temperature control. The heater requires a customer-supplied 115V remote supply source.	Enclosure

Dissipated Watt Losses

Horsepower	40	50	60	75	100	125	150	200	250	300	350	400	450	500	600	700	800
Watts	1844	2170	2540	3040	4011	4940	5730	8020	9383	11600	13600	15700	16250	17976	20393	27200	31400

Conformal (Varnished) Coating ^①

Chassis Frame	Delivery Code	Chassis Frame	Delivery Code
FR6	FP	FR9	FP
FR7	FP	FR10	FP
FR8	FP	FR11	FP
—	—	FR12	FP

480V Input Disconnect Selection ^②

Horsepower	P1 Input Breaker	Bypass Motor Circuit Protector (RA, RB, RC, RD)
25	HFD3050	HMCP050K2C
30	HFD3060	HMCP100R3C
40	HFD3080	HMCP100R3C
50	HFD3100	HMCP100R3C
60	HFD3100	HMCP150T4C
75	HFD3125	HMCP150T4C
100	HFD3150	HMCP150U4C
125	HFD3200	HMCP250W5C
150	HFD3225	HMCP250W5C
200	HKD3300	HMCP400X5C
250	HKD3400	HMCP400X5C
300–400	HLD3600	HMCP600L6W
500–600	HND3800	HMCP800X7W
650–800	HND312	^③

Notes

- ① See catalog number description to order.
- ② Contact factory for 208V and 575V applications.
- ③ Contact factory.

Enclosed Drive Options

Light Options

Description	Catalog Number Suffix
Power on, run, fault LED lights (22 mm)	L1
Power on, fault LED lights (22 mm)	L3
Green LED run light (22 mm)	LA
Green LED stop light (22 mm)	LD
Red LED run light (22 mm)	LE
Red LED stop light (22 mm)	LF
Red LED fault light (22 mm)	LG
Power on white LED light (22 mm)	LJ
Miscellaneous LED light (22 mm)	LU

Control Options

Description	Catalog Number Suffix
Door-mounted speed potentiometer	K1
Door-mounted speed potentiometer with HOA selector switch	K2
3–15 psig follower	K3
HOA selector switch	K4
MANUAL/AUTO reference switch	K5
START-STOP pushbuttons	K6
Type D2 control relay	SD
On-delay relay	SE
Off-delay relay	SF
Additional terminal blocks per 4 points	SD

Bypass Control Options

Description	Catalog Number Suffix
Bypass test switch used with RA and RB	KF
Inverter/bypass pilot lights	L2

Meter Options

Description	Catalog Number Suffix
Standard elapsed time meter	KO
Frequency meter	KS
MP-3000 relay with URTD	KV
MP-3000 relay with URTD and CTs	KU

Enclosure Options

Enclosure Size	Catalog Number Suffix
10.00 Inch (254.0 mm) Expansion	
7	S7
8	S7
9	S7
10	S7
11	S7
20.00 Inch (508.0 mm) Expansion	
7	S8
8	S8
9	S8
10	S8
11	S8
Space Heater ^①	
7	S9
8	S9
9	S9
10	S9
11	S9
Plastic Nameplate	
7	SN
8	SN
9	SN
10	SN
11	SN

Note

^① Requires customer-supplied 115 Vac supply.

208V and 230V Power Options, 25–200 hp

Description	Catalog Number Suffix
Input breaker	P1
Output contactor	PE
Single overload relay	PH
Dual overload relays	PI
MOV	P7
50 kA surge protective device	P8
100 kA surge protective device	P9

480 and 575V Power Options, 25–800 hp

Description	Catalog Number Suffix
Input breaker	P1
Output contactor	PE
Output filter	PF
MotoRx (300–600 Ft) DV/DT filter	PG
Single overload relay	PH
Dual overload relays	PI
Input MOV	P7
50 kA surge protective device	P8
100 kA surge protective device	P8

208V and 230V Bypass Options, 25–200 hp

Description	Catalog Number Suffix
Manual HOA bypass controller	RA
IOB bypass controller	RB
Auto transfer HOA bypass controller	RC
Auto transfer IOB bypass controller	RD
Reduced voltage starter for bypass	RG
Dual overloads for bypass	PN

480 and 575V Bypass Options, 25–800 hp

Description	Catalog Number Suffix
Manual HOA bypass controller	RA
IOB bypass controller	RB
Auto transfer HOA bypass controller	RC
Auto transfer IOB bypass controller	RD
Reduced voltage starter for bypass	RG
Dual overloads for bypass	PN

Technical Data and Specifications

Enclosed 18-Pulse Drives

Description	Specification
Primary Design Features	
45–66 Hz input frequency	Standard
Output: AC volts maximum	Input voltage base
Output frequency range	0–320 Hz
Initial output current (I_H)	250% for 2 seconds
Overload (1 minute [I_H/I_L])	150%/110%
Enclosure space heater	Optional
Oversize enclosure	Standard
Output contactor	Optional
Bypass motor starter	Optional
Listings	UL, cUL, 508C
Protection Features	
Incoming line fuses	Standard 200 kAIC rating
AC input circuit disconnect	Optional
Phase rotation insensitive	Standard
EMI filter	Standard FR6 thru FR9 ^①
Input phase loss protection	Standard
Input overvoltage protection	Standard
Line surge protection	Standard
Output short-circuit protection	Standard
Output ground fault protection	Standard
Output phase protection	Standard
Overtemperature protection	Standard
DC overvoltage protection	Standard
Drive overload protection	Standard
Motor overload protection	Standard
Programmer software	Optional
Local/remote keypad	Standard
Keypad lockout	Standard
Fault alarm output	Standard
Built-in diagnostics	Standard
Surge protective device	Optional

Description	Specification
Input/Output Interface Features	
Setup adjustment provisions	
Remote keypad/display	Standard
Personal computer	Standard
Operator control provisions	
Drive mounted keypad/display	Standard
Remote keypad/display	Standard
Conventional control elements	Standard
Serial communications	Optional
115 Vac control circuit	Optional
Speed setting inputs	
Keypad	Standard
0–10 Vdc potentiometer/voltage signal	Standard
4–20 mA isolated	Configurable
4–20 mA differential	Configurable
3–15 psig	Optional
Analog outputs	
Speed/frequency	Standard
Torque/load/current	Programmable
Motor voltage	Programmable
Kilowatts	Programmable
0–10 Vdc signals	Configurable w/jumpers
4–20 mA DC signals	Standard
Isolated signals	Standard
Discrete outputs	
Fault alarm	Standard
Drive running	Standard
Drive at set speed	Programmable
Optional parameters	14
Dry contacts	2 Form C contacts available
Additional discrete outputs	Optional
Communications	
RS-232	Standard
RS-422/485	Optional
DeviceNet™	Optional
Modbus RTU	Optional
CANopen (slave)	Optional
PROFIBUS-DP	Optional
LonWorks	Optional
Johnson Controls Metasys N2	Optional
EtherNet/IP/Modbus TCP	Optional
BACnet	Optional

Note

^① The EMI filter is optional in FR10 and larger.

Enclosed 18-Pulse Drives

Description	Specification
Performance Features	
Sensorless vector control	Standard
Volts/hertz control	Standard
IR and slip compensation	Standard
Electronic reversing	Standard
Dynamic braking	Optional
DC braking	Standard
PID set point controller	Programmable
Critical speed lockout	Standard
Current (torque) limit	Standard
Adjustable acceleration/deceleration	Standard
Linear or S curve accel/decel	Standard
Jog at preset speed	Standard
Thread/preset speeds	7
Automatic restart	Selectable
Coasting motor start	Standard
Coast or ramp stop selection	Standard
Elapsed time meter	Optional
Carrier frequency adjustment	1–16 kHz
Standard Conditions for Application and Service	
Maximum operating ambient temperature	0–50°C up to FR9 0–40°C FR10 and larger, consult factory for 50°C rating above FR9
Storage temperature	–40 to 60°C
Humidity (maximum), noncondensing	95%
Altitude (maximum without derate)	3300 ft (1000m)
Line voltage variation	+10/–15%
Line frequency variation	45–66 Hz
Efficiency	>95%
Power factor (displacement)	0.99+
Power factor (apparent)	0.99

Standard I/O Specifications

Description	Specification
Six–digital input programmable	24V: "0" ≤10V, "1" ≥18V, R _i >5 kohms
Two–analog input configurable w/jumpers	Voltage: 0–±10V, R _i >200 kohms Current: 0 (4)–20 mA, R _i = 250 ohms
Two–digital output programmable	Form C relays 250 Vac 30 Vdc 2 amp resistive
One–analog output programmable configurable w/jumper	0–20 mA, R _L max. 500 ohms 10 bits ±2%

I/O Specifications for Control/Communication Options

Description	Specification
Analog voltage, input	0–±10V, R _i ≥200 kilohms
Analog current, input	0 (4)–20 mA, R _i = 250 ohms
Digital input	24V: "0" ≤10V, "1" ≥18V, R _i >5 kilohms
Auxiliary voltage	24V (±20%), max. 50 mA
Reference voltage	10V ±3%, max. 10 mA
Analog current, output	0 (4)–20 mA, R _L = 500 kilohms, resolution 10 bit, accuracy ≤±2%
Analog voltage, output	0 (2)–10V, R _L ≥1 kilohm, resolution 10 bit, accuracy ≤±2%
Relay output max. switching voltage	300 Vdc, 250 Vac
Relay output max. switching load	3A/24 Vdc, 300 Vdc, 250 Vac ①
Relay output max. continuous load	2A rms
Thermistor input	R _{trip} = 4.7 kohms

Note

① For applications above 3A consult instruction manual.

Wiring Diagrams

Power Diagram Up to FR9

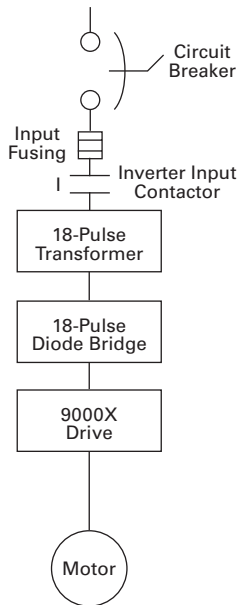

Power Diagram Up to FR9 with Bypass

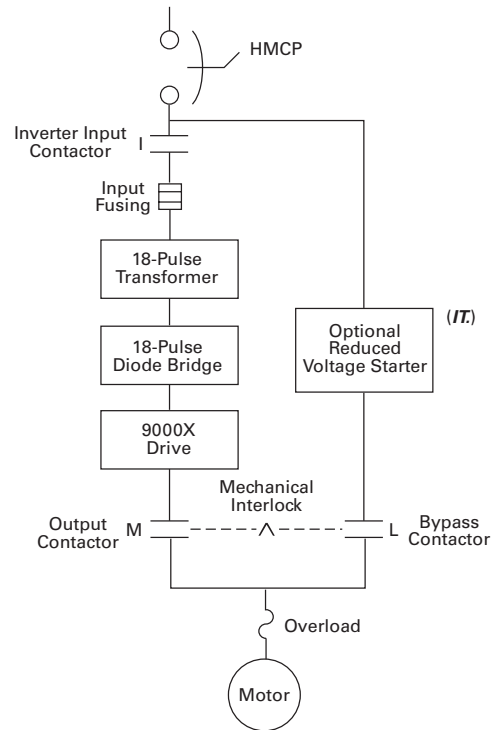

Power Diagram FR10 and Larger

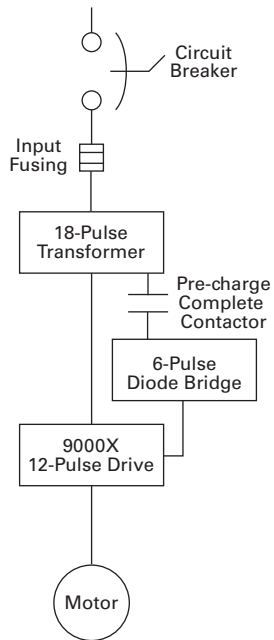

Power Diagram FR10 and Larger with Bypass

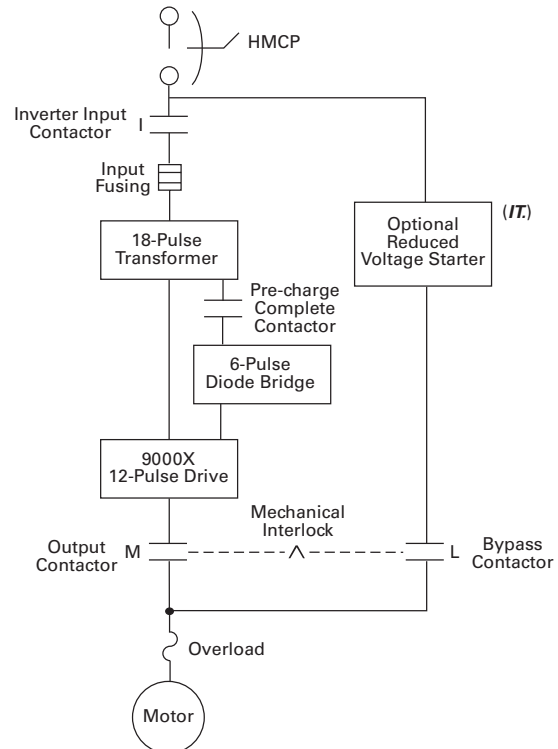

2.8

Adjustable Frequency Drives

Low Harmonic Drives

Dimensions

Approximate Dimensions in Inches (mm)

2

Enclosure Size 7

25–150 hp I_L and 25–125 hp I_H 480V — 25–100 hp I_L and 25–75 hp I_H 575V

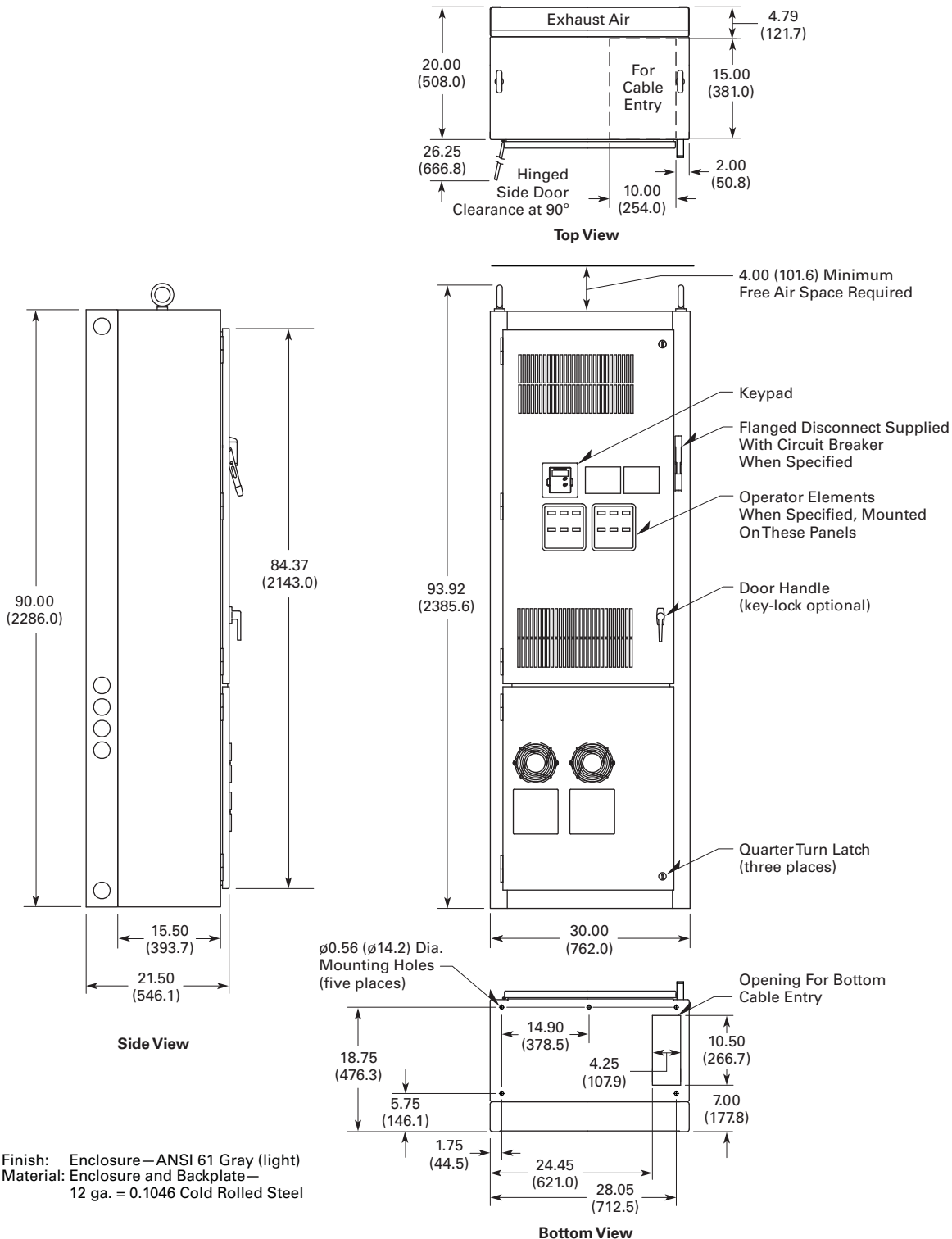

Approximate Dimensions in Inches (mm)

Enclosure Size 8

200–250 hp I_L and 150–200 hp I_H 480V — 125–200 hp I_L and 100–150 hp I_H 575V

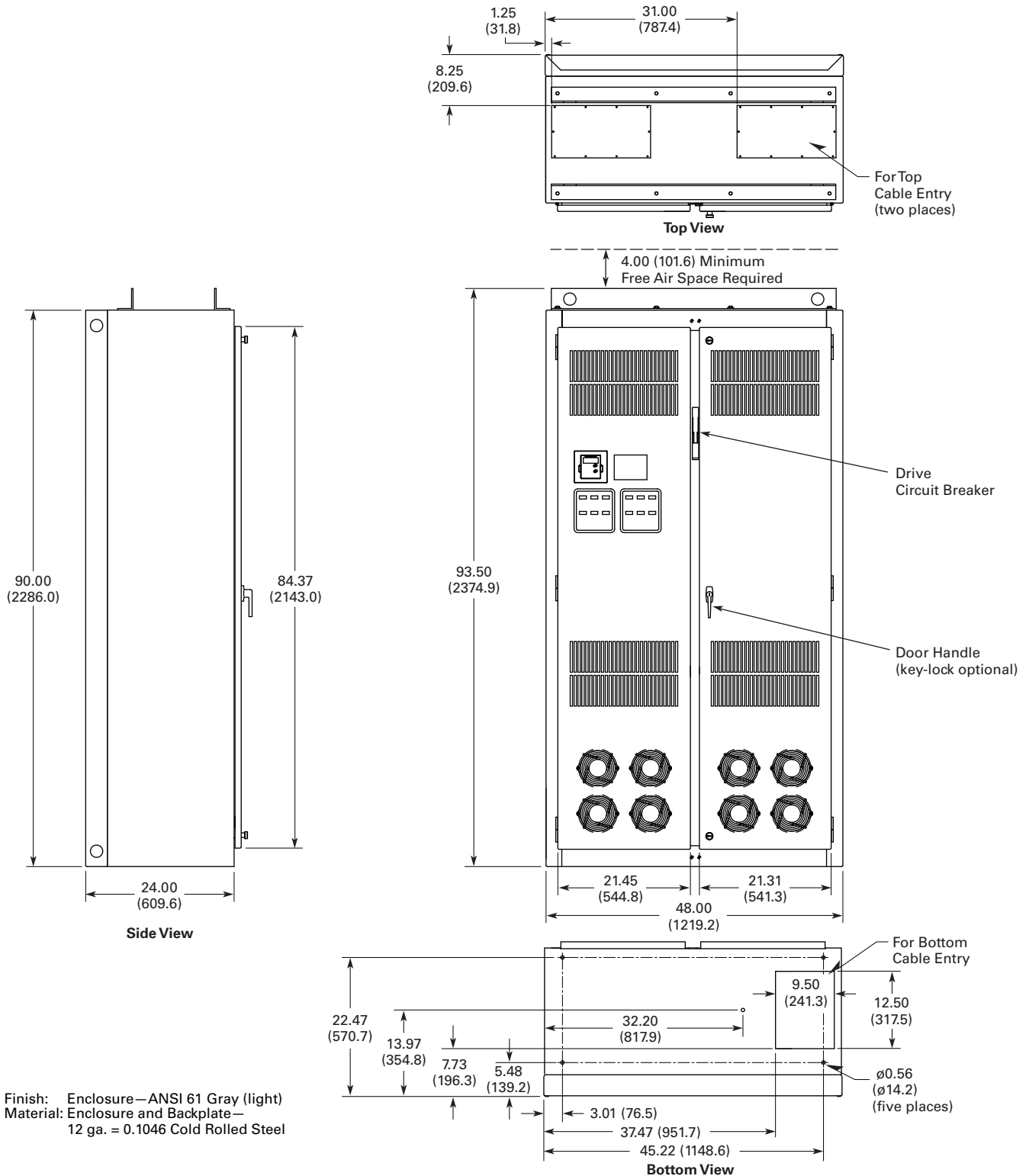

2.8

Adjustable Frequency Drives

Low Harmonic Drives

Approximate Dimensions in Inches (mm)

Enclosure Size 9

2

300–400 hp I_L and 250–350 hp I_H 480V—250–400 hp I_L and 200–300 hp I_H 575V

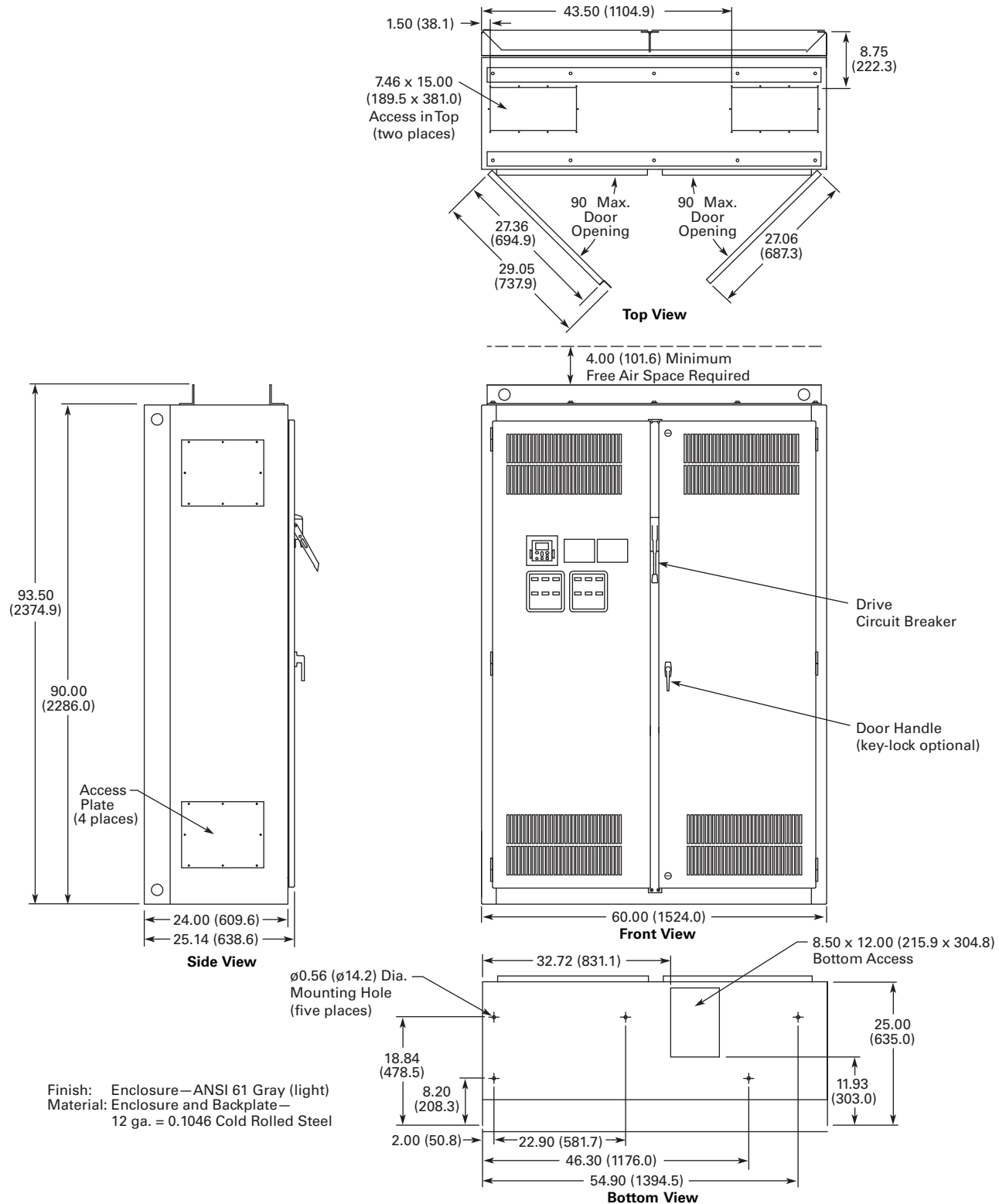

Approximate Dimensions in Inches (mm)

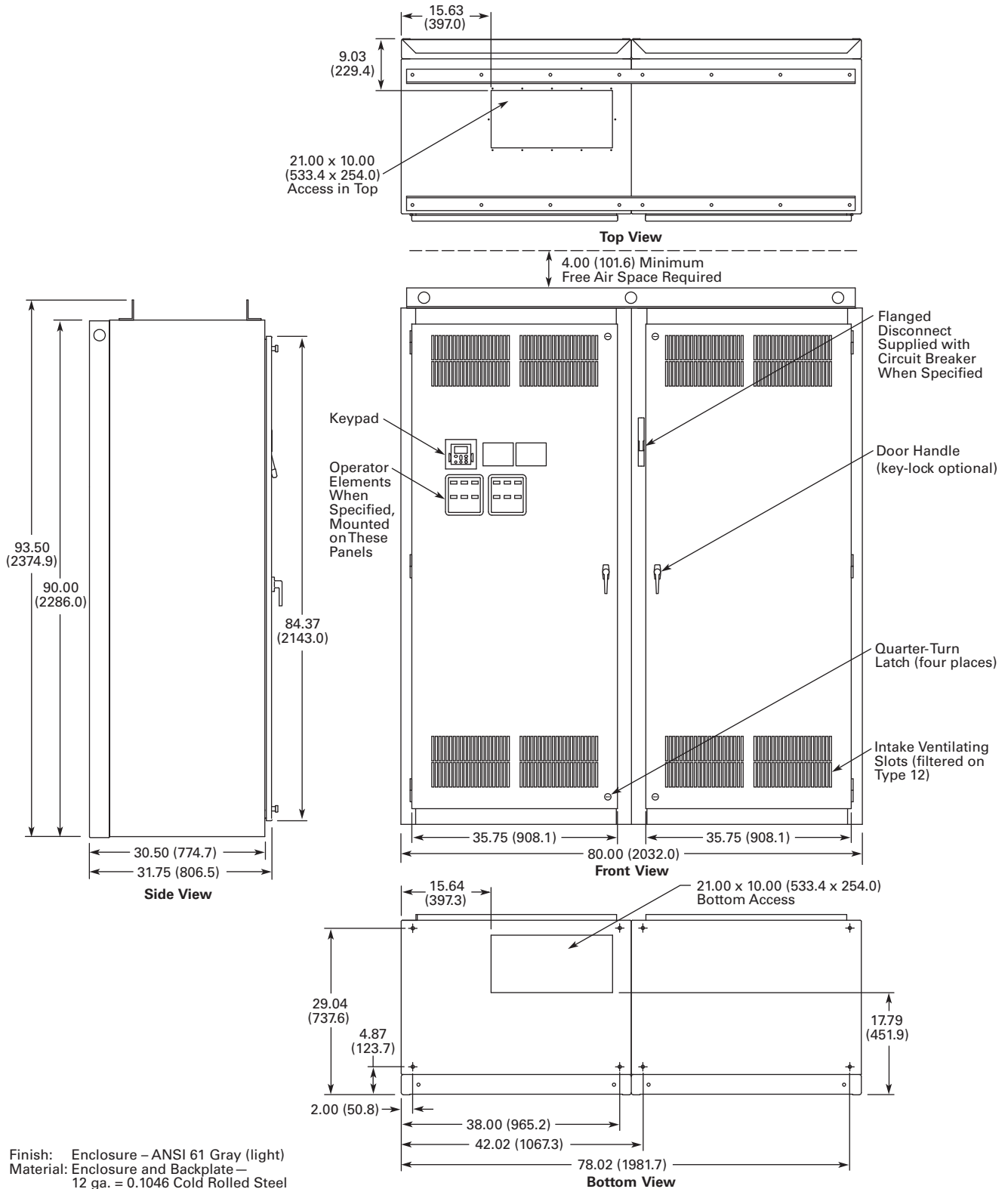
Enclosure Size 10**500–600 hp I_L and 400–500 hp I_H 480V—500–600 hp I_L and 400–500 hp I_H 575V**

2.8

Adjustable Frequency Drives

Low Harmonic Drives

Approximate Dimensions in Inches (mm)

Enclosure Size F Type 3R Drives

2

25–250 hp I_L and 25–200 hp I_H 480V — 25–200 hp I_L and 25–150 hp I_H 575V Type 3R Drives

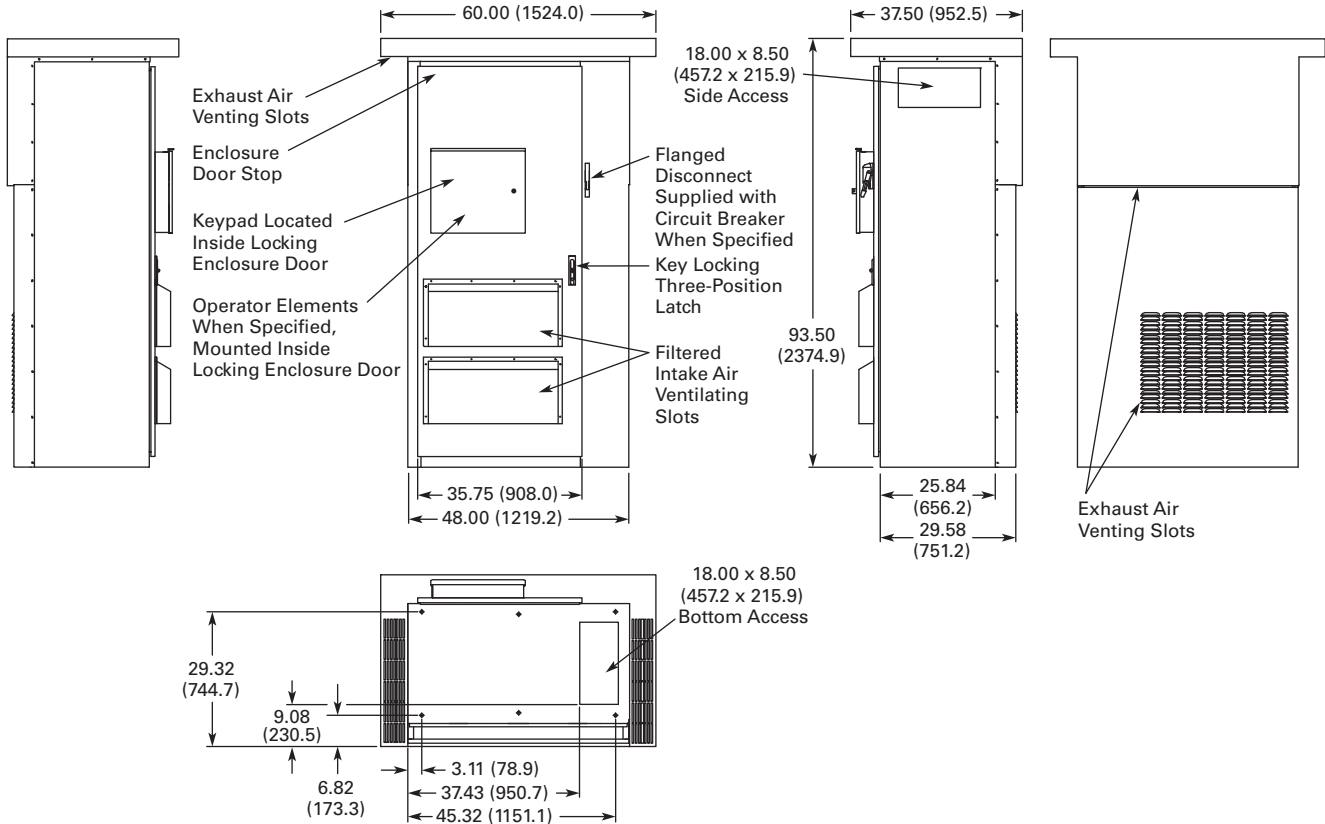

Enclosed 18-Pulse Drive Enclosure Dimensions

Enclosure Size ^①	Width	Height	Depth	Approx. Shipping Weight in Lbs (kg)
7	30.00 (762.0)	90.00 (2286.0)	21.50 (546.1)	1000 (454)
8	48.00 (1219.2)	90.00 (2286.0)	26.14 (664.0)	1400 (636)
9	60.00 (1524.0)	90.00 (2286.0)	25.74 (653.8)	1800 (817)
10	80.00 (2032.0)	90.00 (2286.0)	31.75 (806.5)	2100 (953)
11 ^{②③}	120.00 (3048.0)	90.00 (2286.0)	25.74 (653.8)	2500 (1,135)
F ^④	60.00 (1524.0)	93.50 (2374.9)	37.50 (952.5)	2500 (1,135)

Notes

- ① Enclosure sizes accommodate drive and options, including bypass and disconnect. For other power options, consult your Eaton representative.
- ② Consult factory. Limited power options available.
- ③ Enclosure size 11 consists of two of the enclosure size 9.
- ④ All Type 3R drives use the Size F enclosure.

LCX9000 Liquid Cooled Adjustable Frequency Drives

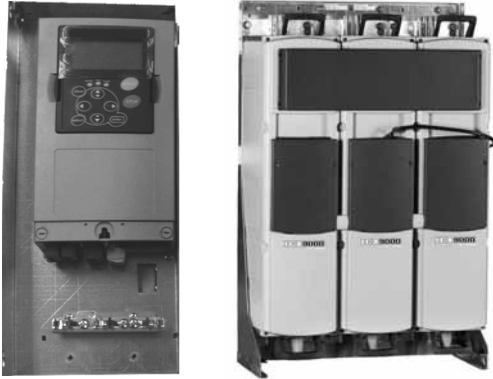

Contents

Description**Page**

LCX9000 Drives	
Catalog Number Selection	V6-T2-264
Product Selection	V6-T2-265
Options	V6-T2-268
Technical Data and Specifications	V6-T2-270
Wiring Diagrams	V6-T2-271
Dimensions	V6-T2-273

Product Description

The LCX9000 Liquid Cooled Drive family continues Eaton's tradition of providing state-of-the-industry products, by taking advantage of liquid cooling technology in lieu of air-cooling techniques.

The LCX9000 drives are liquid-cooled products that utilize potable water or a water-glycol mixture as a cooling medium.

Features and Benefits

- Compact size and low heat transfer rates allow enclosure size to be greatly reduced, which is especially beneficial in UL Type 4X applications
- Design is modular, with control and power modules independent of each other. Connection between power and control modules can be direct or extended via a fiber optic cable
- Same reliable control module and operating system as the SPX9000 air-cooled drives
- CE mark ensures compliance with the Electromagnetic Compatibility Directive (EMC) and the Low Voltage Directive (LVD)
- Reliable drive with over 500,000 hours MTBF based on MIL 217
- Currently supports DeviceNet, PROFIBUS-DP, Modbus RTU and Modbus TCP communication protocols
- Separately mounted line reactor included with AC fed models

Standards and Certifications

- CE



Catalog Number Selection

LCX9000 Liquid Cooled Adjustable Frequency Drives

2

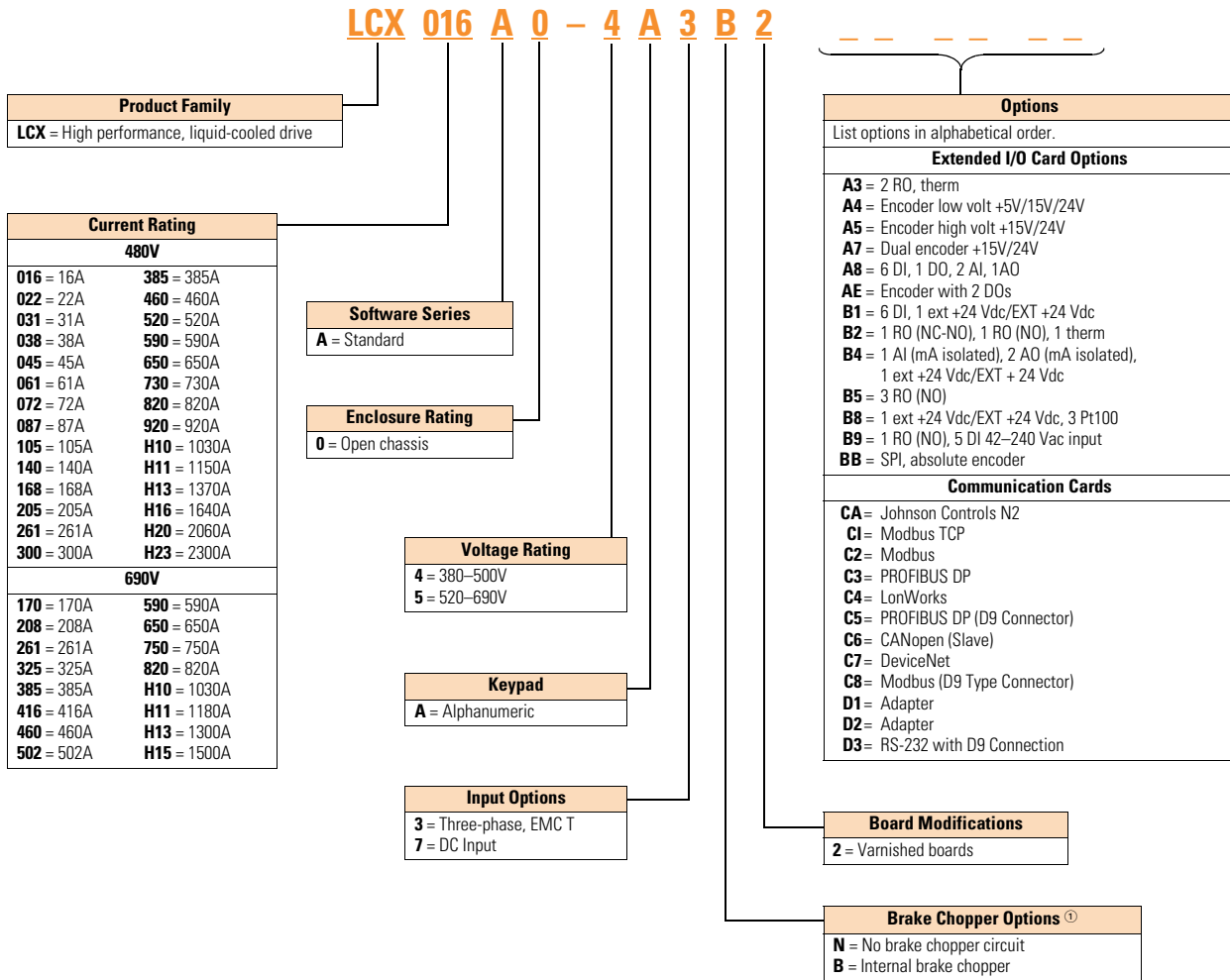

Note

① Brake chopper is only available in 480V CH3 drives.

Product Selection

LCX9000 Liquid Cooled Drives



380–500 Vac Liquid Cooled Drives

Motor Output

Current

Thermal, I _{th} (A)	I _L (A)	I _H (A)	kW	Chassis	Catalog Number
16	15	11	7.5	CH3	LCX016A0-4A3N2
22	20	15	11	CH3	LCX022A0-4A3N2
31	28	21	15	CH3	LCX031A0-4A3N2
38	35	25	18.5	CH3	LCX038A0-4A3N2
45	41	30	22	CH3	LCX045A0-4A3N2
61	55	41	30	CH3	LCX061A0-4A3N2
72	65	48	37	CH4	LCX072A0-4A3N2
87	79	58	45	CH4	LCX087A0-4A3N2
105	95	70	55	CH4	LCX105A0-4A3N2
140	127	93	75	CH4	LCX140A0-4A3N2
168	153	112	90	CH5	LCX168A0-4A3N2
205	186	137	110	CH5	LCX205A0-4A3N2
261	237	174	132	CH5	LCX261A0-4A3N2
300	273	200	160	CH61	LCX300A0-4A3N2
385	350	257	200	CH61	LCX385A0-4A3N2
460	418	307	250	CH72	LCX460A0-4A3N2
520	473	347	250	CH72	LCX520A0-4A3N2
590	536	393	315	CH72	LCX590A0-4A3N2
650	591	433	355	CH72	LCX650A0-4A3N2
730	664	487	400	CH72	LCX730A0-4A3N2
820	745	547	450	CH63	LCX820A0-4A3N2
920	836	613	500	CH63	LCX920A0-4A3N2
1030	936	687	560	CH63	LCXH10A0-4A3N2
1150	1045	766	600	CH63	LCXH11A0-4A3N2
1370	1245	913	700	CH74	LCXH13A0-4A3N2
1640	1491	1093	900	CH74	LCXH16A0-4A3N2
2060	1873	1373	1100	CH74	LCXH20A0-4A3N2
2300	2091	1533	1200	CH74	LCXH23A0-4A3N2

LCX9000 Liquid Cooled Drives



525–690 Vac Liquid Cooled Drives

Motor Output

Current

Thermal, I_{th} (A)	I_L (A)	I_H (A)	kW	Chassis	Catalog Number
170	155	113	110	CH61	LCX170A0-5A3N2
208	189	139	132	CH61	LCX208A0-5A3N2
261	237	174	160	CH72	LCX261A0-5A3N2
325	295	217	200	CH72	LCX325A0-5A3N2
385	350	257	250	CH72	LCX385A0-5A3N2
416	378	277	250	CH72	LCX416A0-5A3N2
460	418	307	300	CH72	LCX460A0-5A3N2
502	456	335	355	CH72	LCX502A0-5A3N2
590	536	393	400	CH63	LCX590A0-5A3N2
650	591	433	450	CH63	LCX650A0-5A3N2
750	682	500	500	CH63	LCX750A0-5A3N2
820	745	547	560	CH74	LCX820A0-5A3N2
920	836	613	650	CH74	LCX920A0-5A3N2
1030	936	687	700	CH74	LCXH10A0-5A3N2
1180	1073	787	800	CH74	LCXH11A0-5A3N2
1300	1182	867	900	CH74	LCXH13A0-5A3N2
1500	1364	1000	1000	CH74	LCXH15A0-5A3N2

540–675 Vdc Liquid Cooled Inverter Units

Drive Output

Current

Thermal I_{th} (A)	Rated Cont. I_L (A)	Rated Cont. I_H (A)	Motor Output Power		Power Loss $c/a/T$ (kW)	Chassis	Catalog Number
			Optimum Motor at I_{th} 400V (kW)	Optimum Motor at I_{th} 500V (kW)			
16	15	11	7.5	11	0.4/0.2/0.6	CH3	LCX016A0-4A7B2
22	20	15	11	15	0.5/0.2/0.7	CH3	LCX022A0-4A7B2
31	28	21	15	18.5	0.7/0.2/0.9	CH3	LCX031A0-4A7B2
38	35	25	18.5	22	0.8/0.2/1.0	CH3	LCX038A0-4A7B2
45	41	30	22	30	1.0/0.3/1.3	CH3	LCX045A0-4A7B2
61	55	41	30	37	1.3/0.3/1.5	CH3	LCX061A0-4A7B2
72	65	48	37	45	1.2/0.3/1.5	CH4	LCX072A0-4A7N2
87	79	58	45	55	1.5/0.3/1.8	CH4	LCX087A0-4A7N2
105	95	70	55	75	1.8/0.3/2.1	CH4	LCX105A0-4A7N2
140	127	93	75	90	2.3/0.3/2.6	CH4	LCX140A0-4A7N2
168	153	112	90	110	2.5/0.3/2.8	CH5	LCX168A0-4A7N2
205	186	137	110	132	3.0/0.4/3.4	CH5	LCX205A0-4A7N2
261	237	174	132	160	4.0/0.4/4.4	CH5	LCX261A0-4A7N2
300	273	200	160	200	4.5/0.4/4.9	CH61	LCX300A0-4A7N2
385	350	257	200	250	5.5/0.5/6.0	CH61	LCX385A0-4A7N2
460	418	307	250	315	5.5/0.5/6.0	CH62	LCX460A0-4A7N2
520	473	347	250	355	6.5/0.5/7.0	CH62	LCX520A0-4A7N2
590	536	393	315	400	7.5/0.6/8.1	CH62	LCX590A0-4A7N2

LCX9000 Liquid Cooled Drives



540–675 Vdc Liquid Cooled Inverter Units, continued

Drive Output

Current			Motor Output Power		Power Loss c/a/T (kW)	Chassis	Catalog Number
Thermal I_{th} (A)	Rated Cont. I_L (A)	Rated Cont. I_H (A)	Optimum Motor at I_{th} 400V (kW)	Optimum Motor at I_{th} 500V (kW)			
650	591	433	355	450	8.5/0.6/ 9.1	CH62	LCX650A0-4A7N2
730	664	487	400	500	10.0/0.7/ 10.7	CH62	LCX730A0-4A7N2
820	745	547	450	560	12.5/0.8/ 13.3	CH63	LCX820A0-4A7N2
920	836	613	500	600	14.4/0.9/ 15.3	CH63	LCX920A0-4A7N2
1030	936	687	560	700	16.5/1.0/ 17.5	CH63	LCXH10A0-4A7N2
1150	1045	766	600	750	18.4/1.0.1/ 19.5	CH63	LCXH11A0-4A7N2
1370	1245	913	700	900	15.5/1.0/ 16.5	CH64	LCXH13A0-4A7N2
1640	1491	1093	900	1100	19.5/1.2/ 20.7	CH64	LCXH16A0-4A7N2
2060	1873	1373	1100	1400	26.5/1.5/ 28.0	CH64	LCXH20A0-4A7N2
2300	2091	1533	1250	1500	29.6/1.7/ 31.3	CH64	LCXH23A0-4A7N2
2470	2245	1647	1300	1600	36.0/2.0/ 38.0	2*CH64	LCXH24A0-4A7N2
2950	2681	1967	1550	1950	39.0/2.4/ 41.4	2*CH64	LCXH29A0-4A7N2
3710	3372	2473	1950	2450	48.0/2.7/ 50.7	2*CH64	LCXH37A0-4A7N2
4140	3763	2760	2150	2700	53.0/3.0/ 66.0	2*CH64	LCXH41A0-4A7N2

710–930 Vdc Liquid Cooled Inverter Unit

Drive Output

Current			Motor Output Power		Power Loss c/a/T (kW)	Chassis	Catalog Number
Thermal I_{th} (A)	Rated Cont. I_L (A)	Rated Cont. I_H (A)	Optimum Motor at I_{th} 400V (kW)	Optimum Motor at I_{th} 500V (kW)			
170	155	113	110	160	4.5/0.2/ 4.7	CH61	LCX170A0-5A7N2
208	189	139	132	200	5.5/0.3/ 5.8	CH61	LCX208A0-5A7N2
261	237	174	160	250	5.5/0.3/ 5.8	CH61	LCX261A0-5A7N2
325	295	217	200	300	6.5/0.3/ 6.8	CH62	LCX325A0-5A7N2
385	350	257	250	355	7.5/0.4/ 7.9	CH62	LCX385A0-5A7N2
416	378	277	250	355	8.0/0.4/ 8.4	CH62	LCX416A0-5A7N2
460	418	307	300	400	8.5/0.4/ 8.9	CH62	LCX460A0-5A7N2
502	456	335	355	450	10.0/0.5/ 10.5	CH62	LCX502A0-5A7N2
590	536	393	400	560	10.0/0.5/ 10.5	CH63	LCX590A0-5A7N2
650	591	433	450	600	13.5/0.7/ 14.2	CH63	LCX650A0-5A7N2
750	682	500	500	700	16.0/0.8/ 16.8	CH63	LCX750A0-5A7N2
820	745	547	560	800	16.0/0.8/ 16.8	CH64	LCX820A0-5A7N2
920	836	613	650	850	18.0/0.9/ 18.9	CH64	LCX920A0-5A7N2
1030	936	687	700	1000	19.0/1.0/ 20.0	CH64	LCXH10A0-5A7N2
1180	1073	787	800	1100	21.0/1.0.1/ 20.1	CH64	LCXH11A0-5A7N2
1300	1182	867	900	1200	27.0/1.4/ 28.4	CH64	LCXH13A0-5A7N2
1500	1364	1000	1050	1400	32.0/1.6/ 33.6	CH64	LCXH15A0-5A7N2
1700	1545	1133	1150	1550	N/A	CH64	LCXH17A0-5A7N2
1850	1682	1233	1250	1650	34.2/1.8/ 36.0	2*CH64	LCXH18A0-5A7N2
2120	1927	1413	1450	1900	37.8/2.0/ 39.8	2*CH64	LCXH21A0-5A7N2
2340	2127	1560	1600	2100	48.6/2.5/ 51.1	2*CH64	LCXH23A0-5A7N2
2700	2455	1800	1850	2450	57.6/3.0/ 60.6	2*CH64	LCXH27A0-5A7N2
3100	2818	2066	2150	2800	N/A	2*CH64	LCXH31A0-5A7N2

Options

9000X Series Option Board Kits

2

The 9000X Series drives can accommodate a wide selection of expander and adapter option boards to customize the drive for your application needs. The drive's control unit is designed to accept a total of five option boards.

The 9000X Series factory installed standard board configuration includes an A9 I/O board and an A2 relay output board, which are installed in slots A and B.

Option Boards

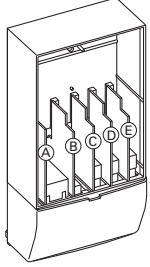

Option Board Kits

Option Kit Description ^①	Allowed Slot Locations ^②	Field Installed Catalog Number	Factory Installed Option Designator	SVX Ready Programs						
				Basic	Local/Remote	Standard	MSS	PID	Multi-P.	PFC
Standard I/O Cards										
2 RO (NC-NO)	B	OPTA2	—	■	■	■	■	■	■	■
6 DI, 1 DO, 2 AI, 1AO, 1 +10 Vdc ref, 2 ext +24 Vdc/EXT +24 Vdc	A	OPTA9	—	■	■	■	■	■	■	■
Extended I/O Cards										
2 RO, therm	B	OPTA3	A3	—	■	■	■	■	■	■
Encoder low Volt +5V/15V/24V	C	OPTA4	A4	—	■	■	■	■	■	■
Encoder high Volt +15V/24V	C	OPTA5	A5	—	■	■	■	■	■	■
Dual encoder +15V/24V	C	OPTA7	A7	—	■	■	■	■	■	■
6 DI, 1 DO, 2 AI, 1 AO	A	OPTA8	A8	—	■	■	■	■	■	■
3 DI (encoder 10–24V), out +15V/+24V, 2 DO (pulse+direction)—SPX only	C	OPTAE	AE	■	■	■	■	■	■	■
6 DI, 1 ext +24 Vdc/EXT +24 Vdc	B, C, D , E	OPTB1	B1	—	—	—	—	—	■	■
1 RO (NC-NO), 1 RO (NO), 1 therm	B, C, D , E	OPTB2	B2	—	—	—	—	—	■	■
1 AI (mA isolated), 2 AO (mA isolated), 1 ext +24 Vdc/EXT +24 Vdc	B, C, D , E	OPTB4	B4	—	■	■	■	■	■	■
3 RO (NO)	B, C, D , E	OPTB5	B5	—	—	—	—	—	■	■
1 ext +24 Vdc/EXT +24 Vdc, 3 Pt100	B, C, D , E	OPTB8	B8	—	—	—	—	—	—	—
1 RO (NO), 5 DI 42–240 Vac input	B, C, D , E	OPTB9	B9	—	—	—	—	—	■	■
SPI, absolute encoder	C	OPTBB	BB	—	—	—	—	—	—	—
Communication Cards ^③										
Modbus	D, E	OPTC2	C2	■	■	■	■	■	■	■
Johnson Controls N2	D, E	OPTC2	CA	—	—	—	—	—	—	—
PROFIBUS DP	D, E	OPTC3	C3	■	■	■	■	■	■	■
LonWorks	D, E	OPTC4	C4	■	■	■	■	■	■	■
PROFIBUS DP (D9 connector)	D, E	OPTC5	C5	■	■	■	■	■	■	■
CANopen (slave)	D, E	OPTC6	C6	■	■	■	■	■	■	■
DeviceNet	D, E	OPTC7	C7	■	■	■	■	■	■	■
Modbus (D9 Type connector)	D, E	OPTC8	C8	■	■	■	■	■	■	■
Modbus TCP	D, E	OPTC1	C1	■	■	■	■	■	■	■
Adapter—SPX only	D, E	OPTD1	D1	■	■	■	■	■	■	■
Adapter—SPX only	D, E	OPTD2	D2	■	■	■	■	■	■	■
RS-232 with D9 connection	D, E	OPTD3	D3	■	■	■	■	■	■	■
Keypad										
9000X Series standard keypad	—	KEYPAD-STD	—	—	—	—	—	—	—	■
9000X Series remote mount keypad unit (keypad not included, includes 10 ft cable, keypad holder, mounting hardware)	—	OPTRMT-KIT-9000X	—	—	—	—	—	—	—	—

Notes

- ① AI = Analog Input; AO = Analog Output, DI = Digital Input, DO = Digital Output, RO = Relay Output
- ② Option card must be installed in one of the slots listed for that card. Slot indicated in bold is the preferred location.
- ③ OPTC2 is a multi-protocol option card.

Line Reactors

The line reactor carries out several functions in the liquid cooled drive. Connection of the line reactor is necessary except if you have a component in your system that performs the same tasks (e.g. a transformer). The line

reactor is needed as an essential component for motor control, to protect the input and DC-link components against abrupt changes of current and voltage as well as to function as a protection

against harmonics. The line reactors are included in the standard delivery of liquid-cooled drives (not inverters). However, you can also order your drive without a line reactor.

Line Reactor Specifications

Drive Rating 480V	Drive Rating 690V	Thermal Current (A)	Nominal Inductance (μ H) A/B ^①	Calculated Loss (W)	Choke Catalog Number (690 Vac)
16 to 22A	12 to 23A	23	1900	145	CHK0023N6A0
31 to 38A	31 to 38A	38	1100	170	CHK0038N6A0
45 to 61A	46 to 62A	62	700	210	CHK0062N6A0
72 to 87A	72 to 87A	87	480	250	CHK0087N6A0
105 to 140A	105 to 140A	145	290	380	CHK0145N6A0
168 to 261A	170 to 261A	261	139/187	460	CHK0261N6A0
300 to 385A	325 to 385A 820 to 1180A ^②	400	90/126	570	CHK0400N6A0
460 to 520A 1370A ^②	416 to 502A 1300 to 1500A ^②	520	65/95	610	CHK0520N6A0
590 to 650A 1640A ^②	590 to 650A	650	51/71	840	CHK0650N6A0
730A 2060A ^②	—	730	45/61	850	CHK0730N6A0
820A 2300A ^②	750A	N/A	N/A	N/A	CHK0820N6A0
920 to 1030A	—	1000	30/41	950	CHK1030N6A0
1150A	—	1150	26/36	1000	CHK1150N6A0

Dimensions, see **Page V6-T2-273**.

Notes

- ^① Inductances for different supply voltages: A = 400–480 Vac; B = 500–690 Vac.
- ^② Drives require three chokes of the designated catalog number with six-pulse supply.

Technical Data and Specifications

2

LCX9000 Products

Description	Specification
General Specifications	
Line voltage	400 to 500 Vac; 525 to 690 Vac; (–10% to 10%) 465 to 800 Vdc; 640 to 1100 Vdc; (–0 to 0%)
Frequency	50/60 Hz
Line voltage variation	–10% to 10%
Input frequency variation	45–66 Hz
Continuous output current	Rated current at incoming cooling liquid temperature of 30°C
Output frequency	0–320 Hz
Drive efficiency	>95%
Power factor (displacement)	0.96
Liquid coolant pressure	87 psi (6 bar) maximum
Liquid coolant flow rate	1.3 to 7.9 gal./min. (5 to 30 liter/min.) minimum depending on drive size
Liquid coolant fittings	Standard quick connect, NPT
Operating ambient temperature	–10/50°C
Storage temperature	–40/70°C
Humidity	95% maximum (non-condensing)
Altitude	3300 ft (1000 m) maximum without derating
Enclosure	IP00
Warranty	Standard terms, 3 years with certified start-up
Mains Connection	
Input voltage (V_{in})	400–500 Vac; 525–690 Vac; (–10%–10%) 465–800 Vdc; 640–1100 Vdc; (–0–0%)
Input frequency (f_{in})	45–66Hz
Connection to mains	Once per minute or less (normal case)
Motor Connection	
Output voltage	0– V_{in}
Continuous output current	Rated current at nominal inflow cooling water temperature of 30°C; Overload 2 sec./20 sec.
Starting current	Rated current at 2 sec./20 sec. if output frequency <30 Hz and temperature of heatsink <149°F (65°C)
Output frequency	0–320 Hz (standard); 7200 Hz (special software)
Frequency resolution	Application dependent
Control Characteristics	
Control method	Frequency control (V/f) Open loop: Sensorless vector control Closed loop: Frequency control Closed loop: Vector control
Switching frequency 480V ①	Adjustable with parameter 2.6.9 Up to and including 61-Amp size: 1–16 kHz (factory default, 10 kHz) From 72-Amp size: 1–12 kHz (factory default, 3.6 kHz)
575V ①	1–6kHz (factory default, 1.5kHz)
Frequency reference	Analog input: resolution 0.1% (10 bits); accuracy ±1% Panel reference: resolution 0.01 Hz
Field weakening point	30–320 Hz
Acceleration time	0.1–3000 seconds
Deceleration time	0.1–3000 seconds
Braking torque	DC brake: 30% x T_n (without brake option)

Description	Specification
Ambient Conditions	
Ambient operating temperature	14°F (–10°C), no frost to 122°F (50°C) at I_{th} 122 to 158°F (50 to 70°C), derating required
Storage temperature	–40°F to 158°F (–40 to 70°C) No liquid in heatsink under 32°F (0°C)
Relative humidity	5–96% RH, noncondensing, no dripping water
Air quality	Chemical vapors: IEC 721-3-3, unit in operation, class 3C2 Mechanical particles: IEC 721-3-3, unit in operation, class 3S2 (no conductive dust allowed); No corrosive gases
Altitude	Up to 1,000m: 100% load capacity (no derating) Above 1,000m: Derating of 1% per each 100m required
Vibration	EN 50178, EN 60068-2-6; 5–150 Hz Displacement amplitude: 0.25 mm (peak) at 3–31 Hz Max. acceleration amplitude: 1G at 31–150 Hz
Shock	EN 50178, EN 60068-2-27, UPS drop test (for applicable UPS weights) Storage and shipping: Max. 15G, 11 ms (in package)
Enclosure class	IP00 open frame standard in entire kW/hp range
EMC	
Immunity	Fulfills all EMC immunity requirements
Emissions	EMC level N; EMC level T for IT networks
Safety	
Approvals	EN 50178, EN 60204-1, CE, UL, CUL, FI, GOST R, IEC 61800-5 (See unit nameplate for more detailed approvals.)
Control Connections	
Analog input voltage	0 to +10V, $R_i = 200$ kohm (–10V to +10V joystick control) Resolution 0.1%; accuracy ±1%
Analog input current	0(4)–20 mA, $R_i = 250$ ohm differential
Digital inputs	6 positive or negative logic; 18–24 Vdc
Auxiliary voltage	+24V, ±15%, max. 250 mA
Output reference voltage	+10V, +3%, max. load 10 mA
Analog output	0(4)–20 mA, R_i max. 500 ohm Resolution 10 bits; accuracy ±2%
Digital outputs	Open collector output, 50 mA/48V
Relay outputs	Two programmable change-over relay outputs Switching capacity: 24 Vdc/8A, 250 Vac/8A, 125 Vdc/0.4A Min. switching load: 5V/10 mA

Note

- ① Derating required if higher switching frequency than the default is used.

LCX9000 Products, continued

Description	Specification
Protections	
Overvoltage protection	
480V	911V
575V	1200V
Undervoltage protection	
480V	333V
575V	461V
Ground fault protection	In case of ground fault in motor or motor cable, only the drive is protected
Mains supervision	Trips if any of the input phases are missing (drives only)
Motor phase supervision	Trips if any of the output phases are missing
Unit overtemperature protection	
Alarm limit	149°F (65°C) for heatsink, 158°F (70°C) for circuit boards
Trip limit	158°F (70°C) for heatsink, 185°F (85°C) for circuit boards

Description	Specification
Protections, continued	
Overcurrent protection	Yes
Motor overload protection	Yes
Motor stall protection	Yes
Motor underload protection	Yes
Short-circuit protection	Yes (+24V and +10V reference voltages)
Liquid Cooling	
Allowed cooling agents	Drinking water Water-glycol mixture
Temperature of cooling agent	32 to 86°F (0 to 30°C) at I_{th} for input; 86 to 149°F (30 to 65°C) Max. temperature rise during circulation: 9°F (5°C), no condensation allowed
System max. working pressure	87 psi (6 bar)
System max. peak pressure	580 psi (40 bar)
Pressure loss (at nominal flow)	Varies according to size

Wiring Diagrams

Cooling System Diagrams

Example of a Typical Cooling System

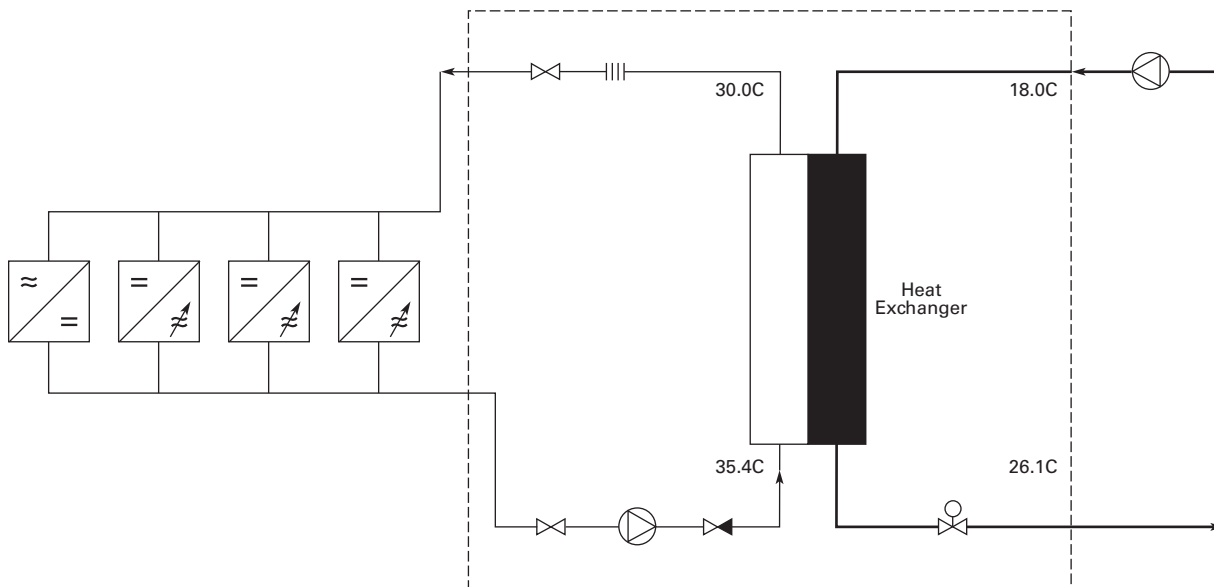

Example PI-Diagram of a Typical Cooling System and Connections

2

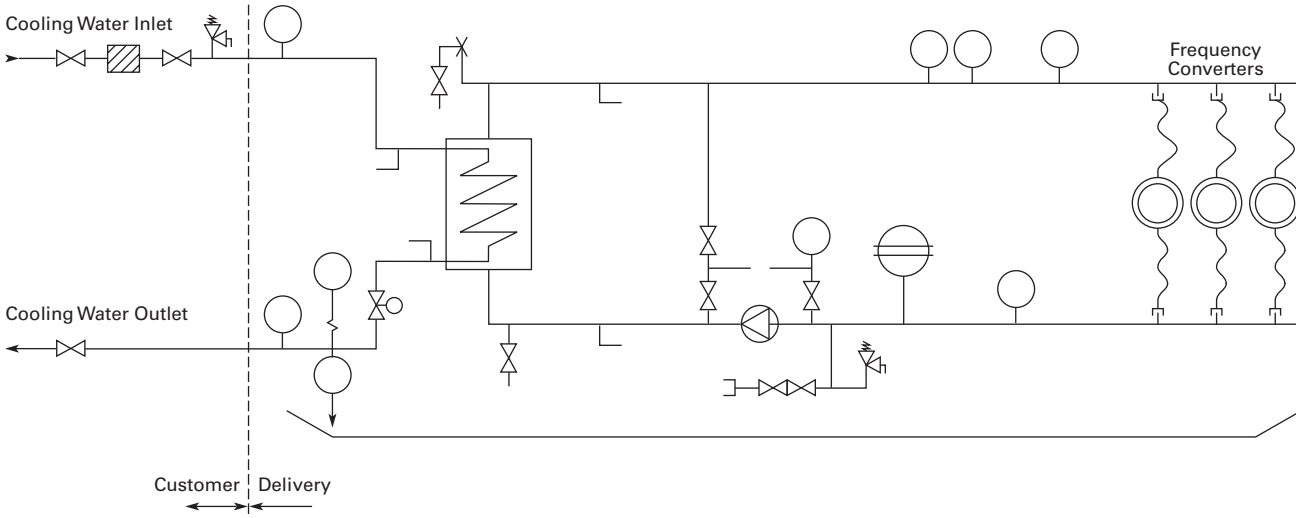

I/O Board Diagrams

A9 Option Board Control Wiring

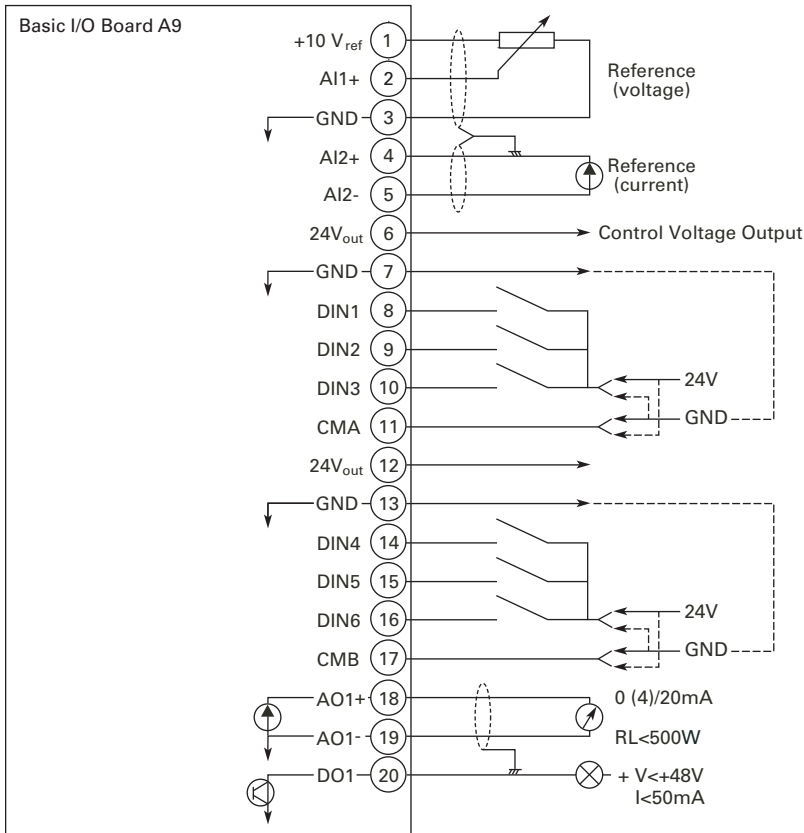

Dotted lines indicate the connections for inverted signals

A2 Option Board Wiring

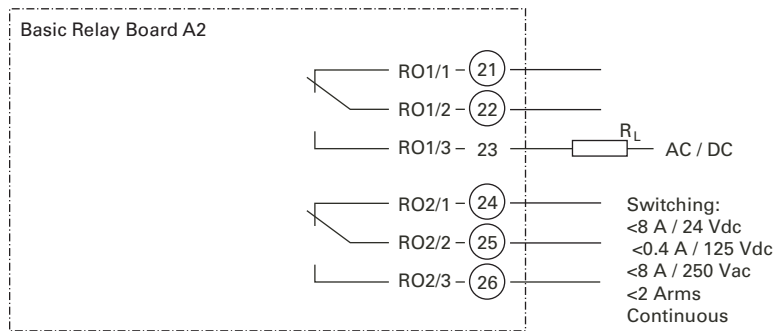

Dimensions

Approximate Dimensions in Inches (mm)

Line Reactors

Sizes Up To 61A

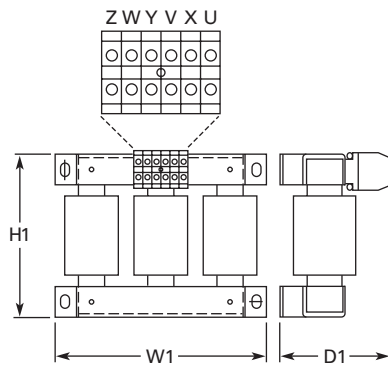

Sizes Larger Than 61A

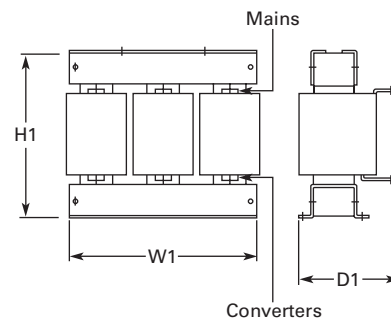

Catalog Number	H1	W1	D1	Weight Lbs (kg)
CHK0023N6A0	7.01 (178)	9.06 (230)	4.76 (121)	22 (10)
CHK0038N6A0	8.23 (209)	10.63 (270)	5.71 (145)	33 (15)
CHK0062N6A0	8.39 (213)	11.81 (300)	6.30 (160)	44 (20)
CHK0087N6A0	9.13 (232)	11.81 (300)	6.69 (170)	57 (26)
CHK0145N6A0	11.50 (292)	11.81 (300)	7.28 (185)	82 (37)
CHK0220N6A0	12.05 (306)	13.86 (352)	7.28 (185)	119 (54)
CHK0325N6A0	13.66 (347)	13.86 (352)	7.28 (185)	132 (60)
CHK0460N6A0	16.54 (423)	13.70 (348)	9.41 (239)	203 (92)
CHK0520N6A0	17.60 (447)	15.51 (394)	10.71 (272)	231 (105)
CHK0590N6A0	20.43 (519)	15.51 (394)	10.71 (272)	276 (125)
CHK0650N6A0	20.51 (521)	15.51 (394)	10.71 (272)	276 (125)
CHK0750N6A0	24.72 (628)	15.51 (394)	11.10 (282)	331 (150)
CHK0820N6A0	24.72 (628)	15.51 (394)	11.10 (282)	331 (150)
CHK1000N6A0	22.68 (576)	19.57 (497)	11.85 (301)	441 (200)
CHK1150N6A0	22.83 (580)	19.57 (497)	11.85 (301)	441 (200)

2.9

Adjustable Frequency Drives

LCX9000 Liquid Cooled Drives

Approximate Dimensions in Inches (mm)

LCX9000 Drives

2

Chassis Size, CH3

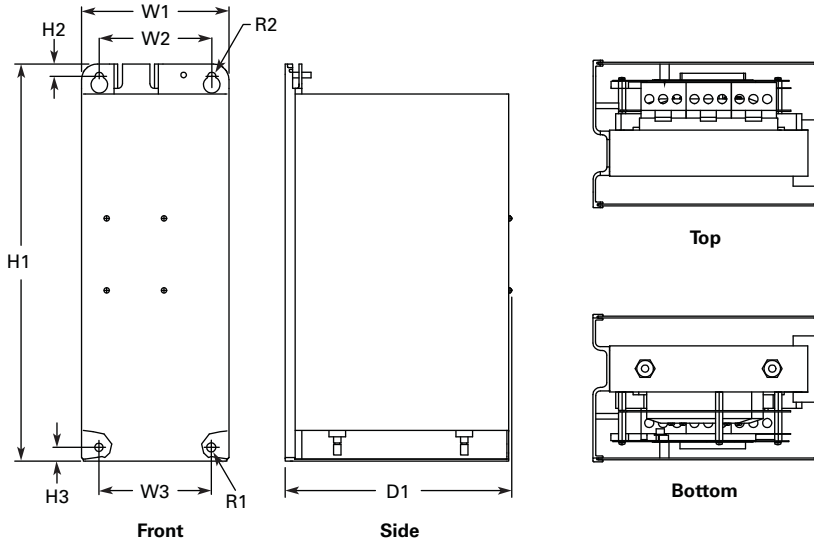

Voltage	Amps	H1	H2	H3	D1	W1	W2	W3	R1 Dia.	R2 Dia.	Weight Lbs (kg)
380–500 Vac	16–61	16.97 (431.0)	0.53 (13.5)	0.59 (15.0)	9.69 (246.0)	6.30 (160.0)	4.80 (122.0)	4.80 (122.0)	0.39 (10.0)	0.35 (9.0)	66 (30)

Chassis Size, CH4

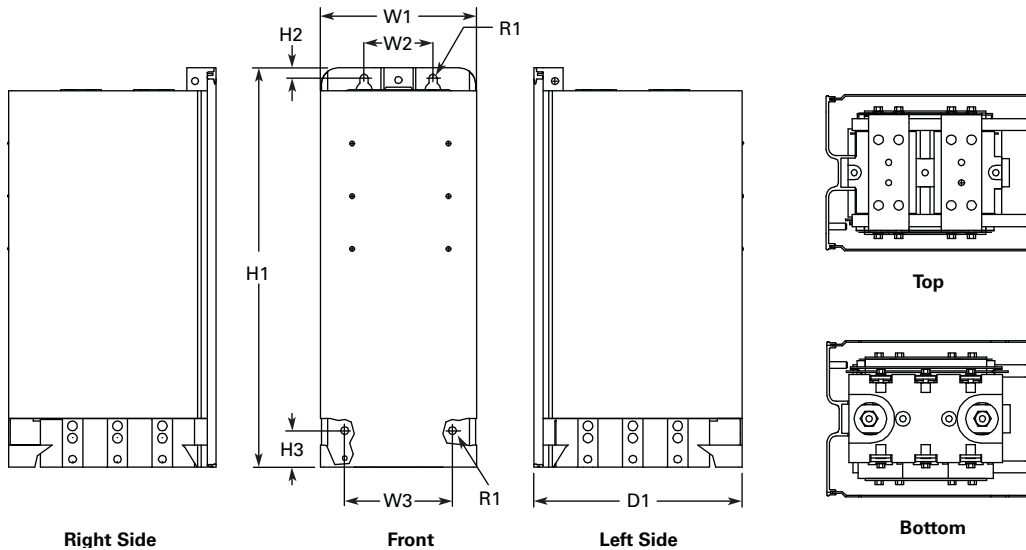

Voltage	Amps	H1	H2	H3	D1	W1	W2	W3	R1 Dia.	R2 Dia.	Weight Lbs (kg)
380–500 Vac	72–140	19.41 (493.0)	0.49 (12.5)	1.77 (45.0)	10.14 (257.5)	7.60 (193.0)	3.35 (85.0)	5.24 (133.0)	0.39 (10.0)	—	77 (35)

Approximate Dimensions in Inches (mm)

Chassis Size, CH5

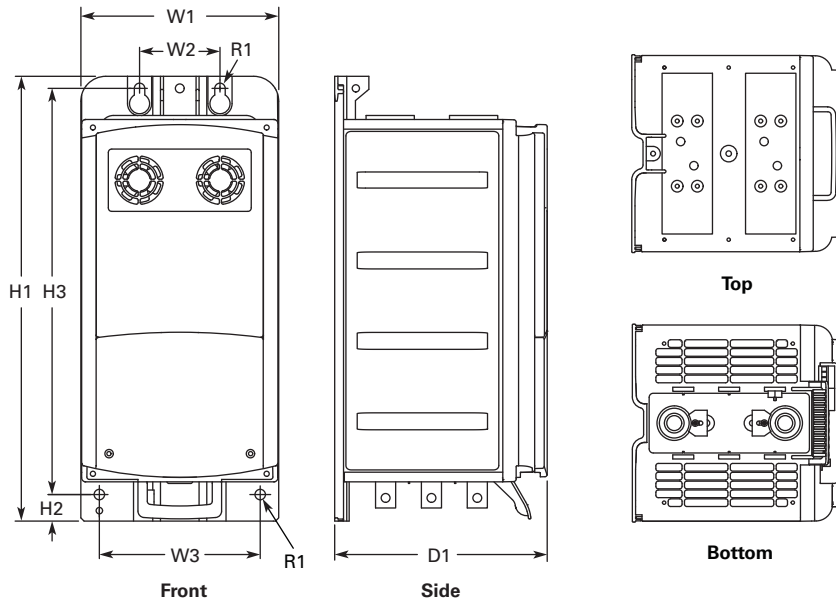

Voltage	Amps	H1	H2	H3	D1	W1	W2	W3	R1 Dia.	R2 Dia.	Weight Lbs (kg)
380–500 Vac	168–261	21.77 (553.0)	1.30 (33.0)	19.88 (505.0)	10.39 (264.0)	9.69 (246)	3.94 (100.0)	7.87 (200.0)	0.51 (13.0)	—	88 (40)

Chassis Size, CH61

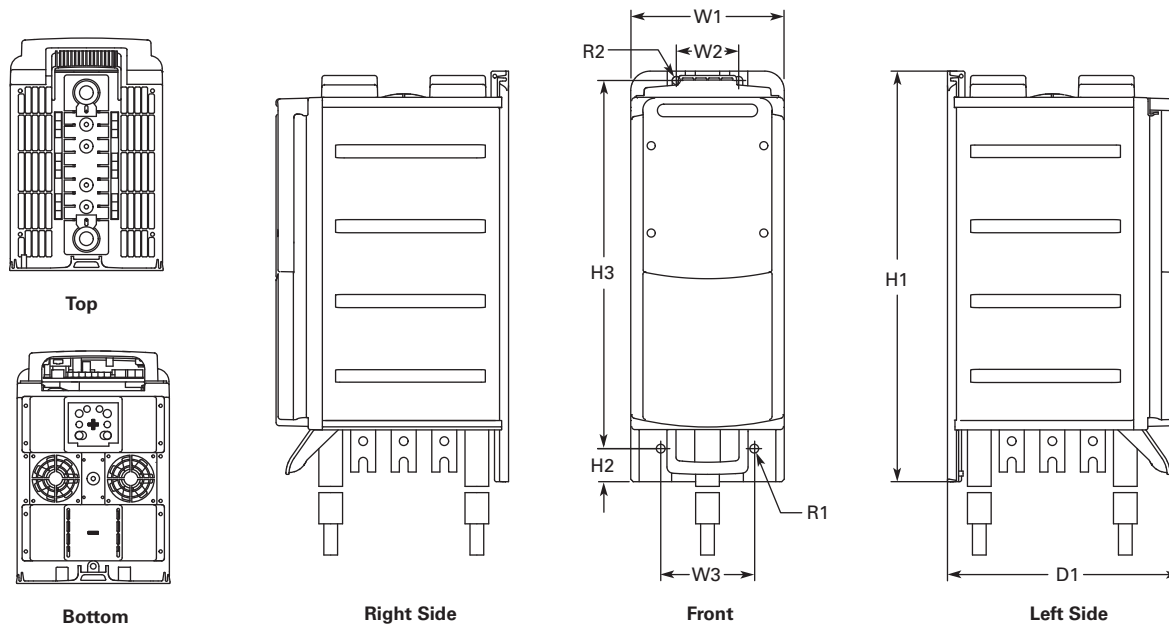

Voltage	Amps	H1	H2	H3	D1	W1	W2	W3	R1 Dia.	R2 Dia.	Weight Lbs (kg)
380–500 Vac	300–385	25.91 (658.0)	2.09 (53.0)	23.23 (590.0)	14.69 (373.0)	9.69 (246.0)	3.94 (100.0)	5.91 (150.0)	0.55 (14.0)	0.51 (13.0)	121 (55)
525–690 Vac	170–208										

2.9

Adjustable Frequency Drives

LCX9000 Liquid Cooled Drives

Approximate Dimensions in Inches (mm)

2

Liquid-Cooled Inverter—Chassis Size, CH62

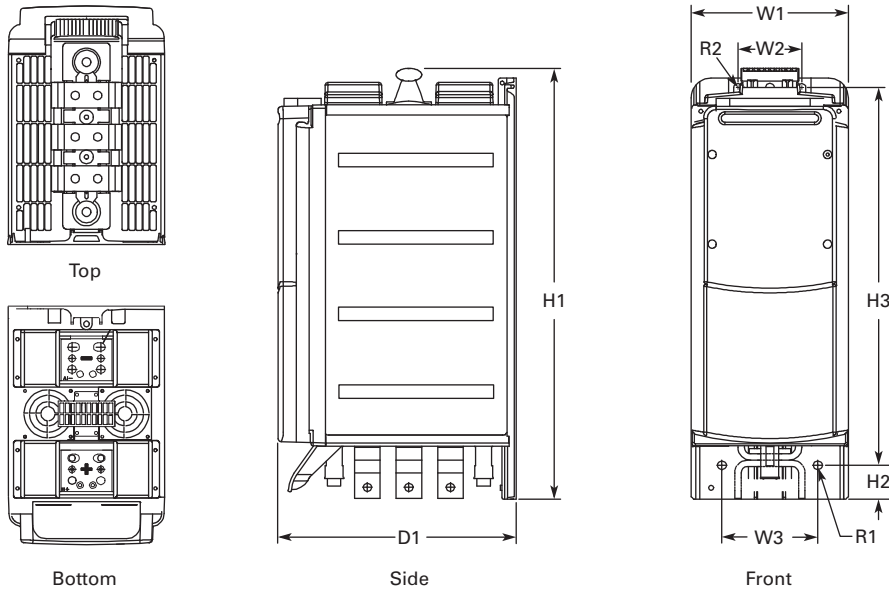

Voltage	Amps	H1	H2	H3	D1	W1	W2	W3	R1 Dia.	R2 Dia.
540–675 Vdc	460–730	26.50	2.0	23.23	14.69	9.69	3.94	5.91	0.55	0.51
710–930 Vdc	325–502	(673)	(53)	(590)	(373)	(246)	(100)	(150)	(14)	(13)

Chassis Size, CH63

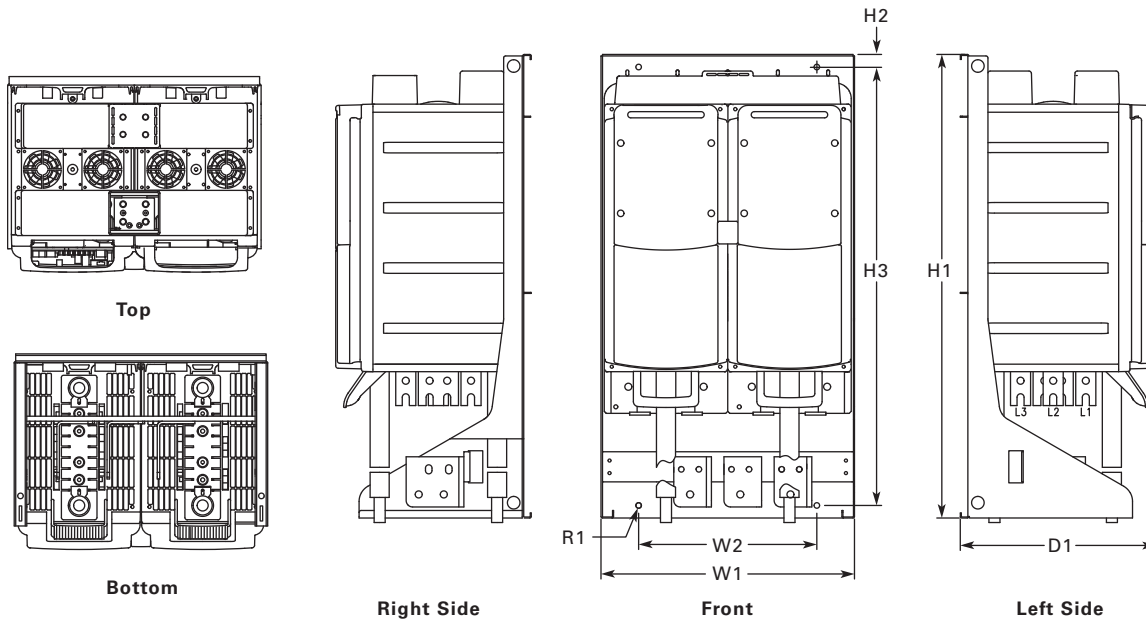

Voltage	Amps	H1	H2	H3	D1	W1	W2	R1 Dia.	Weight Lbs (kg)
380–500 Vac	820–1030	36.36	0.91	34.39	15.35	19.88	13.98	0.43	264 (120)
525–690 Vac	590–750	(923.5)	(23.0)	(873.5)	(390.0)	(505.0)	(355.0)	(11.0)	

Approximate Dimensions in Inches (mm)

Liquid-Cooled Inverter with Mounting Bracket, Chassis Size CH64, IP90

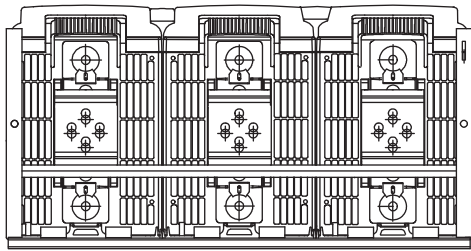

Bottom

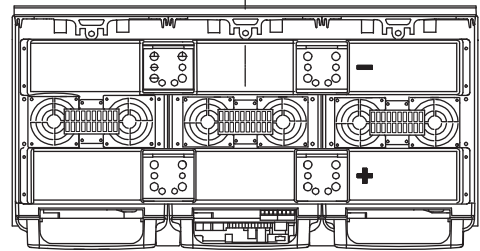

Top

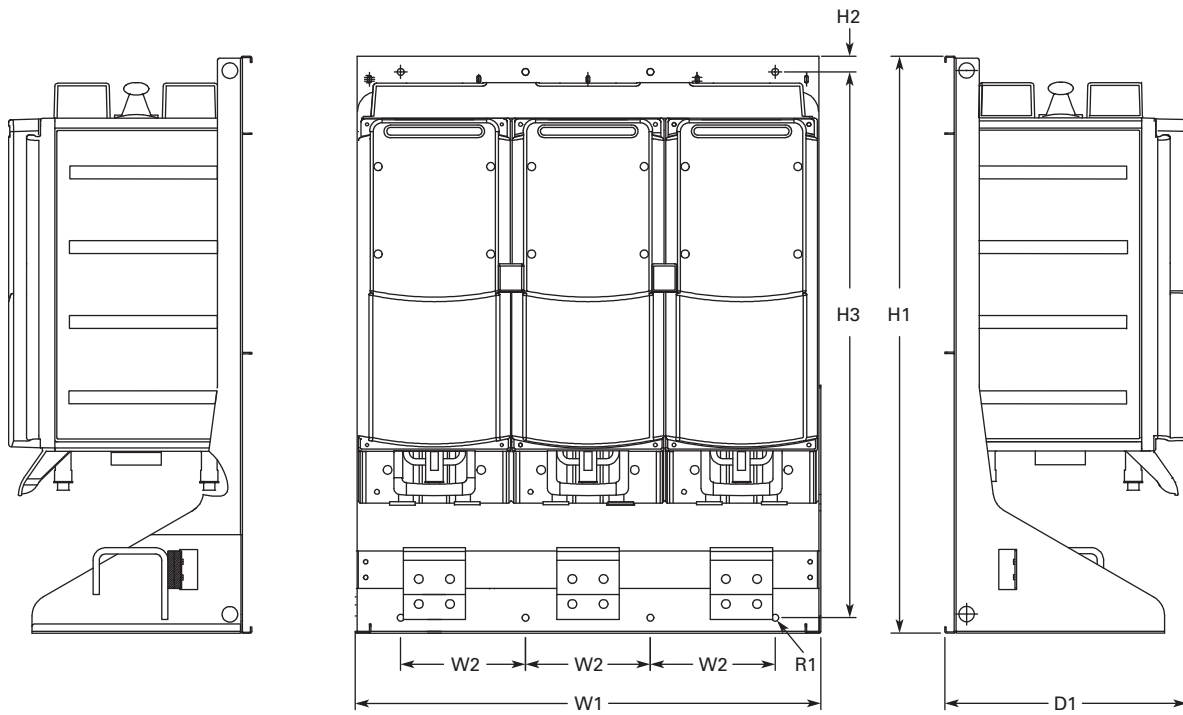

Right Side

Front

Left Side

Voltage	Amps	H1	H2	H3	D1	W1	W2	R1 Dia.
540–675 Vdc	1370–4140	36.38	1.03	34.37	15.35	29.37	7.87	0.43
710–930 Vdc	820–3100	(924)	(26)	(873)	(390)	(746)	(200)	(11)

2.9

Adjustable Frequency Drives

LCX9000 Liquid Cooled Drives

Approximate Dimensions in Inches (mm)

Chassis Size, CH72

2

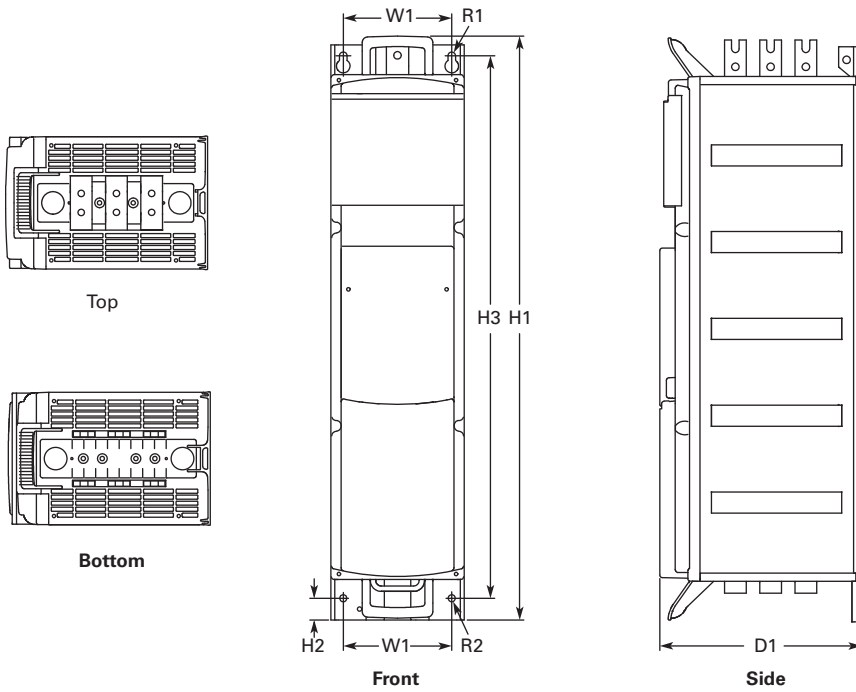

Voltage	Amps	H1	H2	H3	D1	W1	R1 Dia.	R2 Dia.	Weight Lbs (kg)
380–500 Vac	460–730	42.38	1.57	39.37	14.65	7.87	0.55	0.51	198 (90)
525–690 Vac	261–502	(1076.5)	(40.0)	(1000.0)	(372.0)	(200.0)	(14.0)	(13.0)	

Approximate Dimensions in Inches (mm)

Chassis Size, CH74

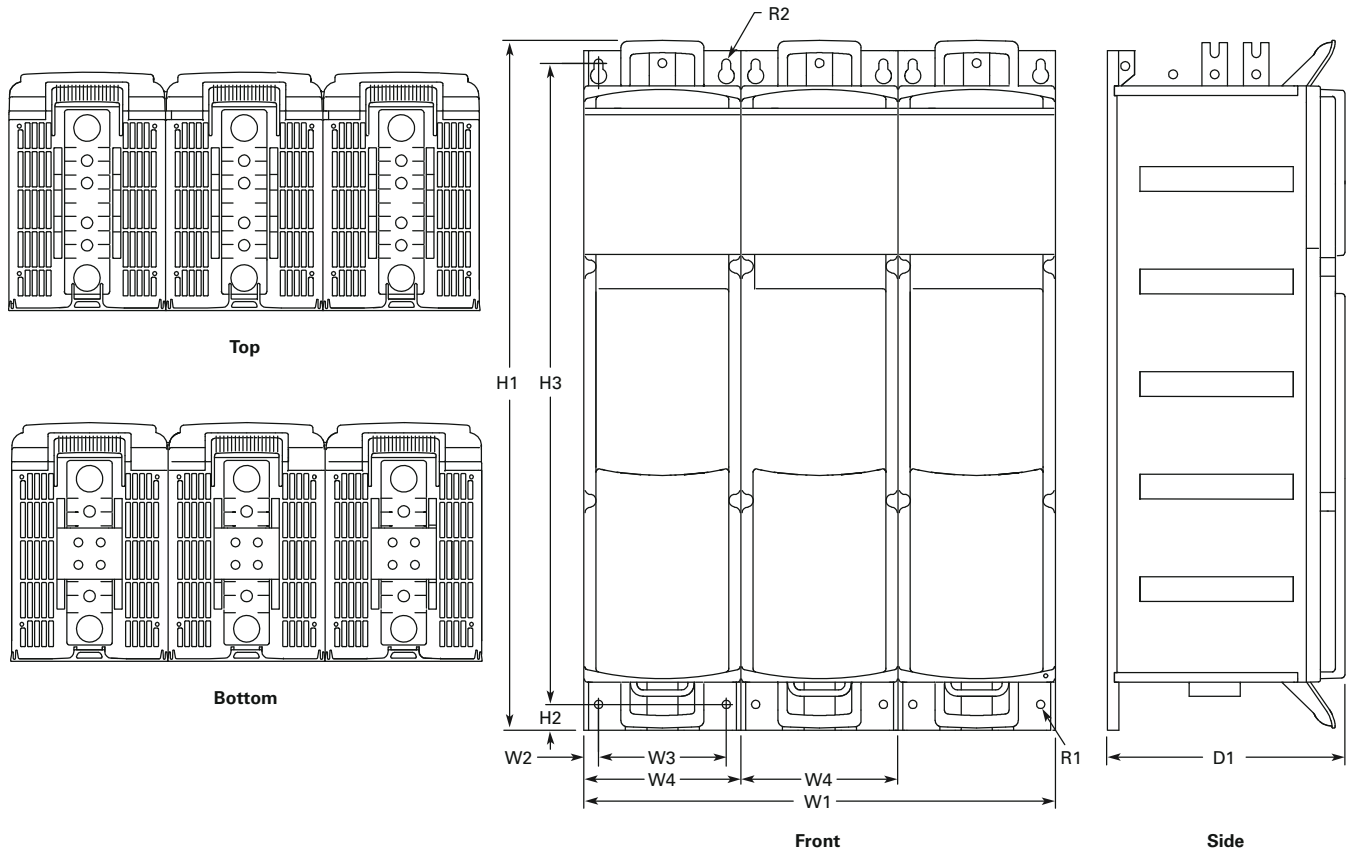

Voltage	Amps	H1	H2	H3	D1	W1	W2	W3	W4	R1 Dia.	R2 Dia.	Weight Lbs (kg)
380–500 Vac	1370–2300	42.38	1.57	39.37	14.65	29.06	0.91	7.87	9.69	0.51	0.55	617 (280)
525–690 Vac	820–1500	(1076.5)	(40.0)	(1000.0)	(372.0)	(738.0)	(23.0)	(200.0)	(246)	(13.0)	(14.0)	

Control Unit

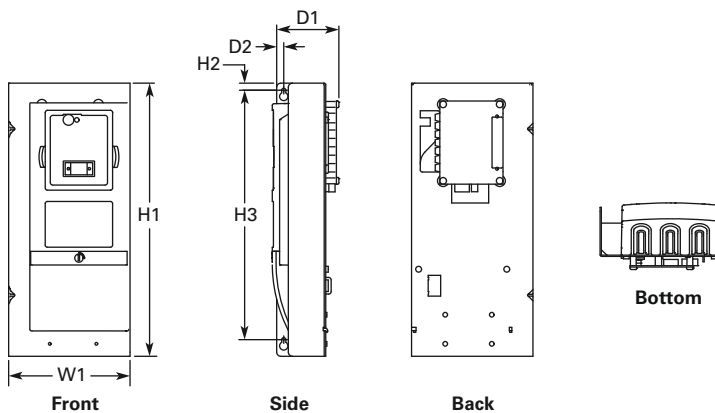

H1	H2	H3	D1	D2	W1
12.93	0.33	11.81	2.95	0.33	5.75
(328.5)	(8.5)	(300.0)	(75.0)	(8.5)	(146.0)

SPA9000/SPN9000/SPI9000 Common DC Bus Drive Products

2



Contents

<i>Description</i>	<i>Page</i>
SPA9000/SPN9000/SPI9000 Common DC Bus Drives	
Application Description	V6-T2-281
Product Comparison	V6-T2-281
Features	V6-T2-282
Standards and Certifications	V6-T2-282
Catalog Number Selection	V6-T2-282
Product Selection	V6-T2-284
Options	V6-T2-287
Technical Data and Specifications	V6-T2-288
Wiring Diagrams	V6-T2-290
Dimensions	V6-T2-291

Product Description

Eaton offers a comprehensive range of common DC bus drive products. The product family covers a number of front-end units and inverter units in the entire power range from 1-1/2 to 2000 horsepower at 460V and 690V. The drive components are built on the SPX9000 technology.

Front-End Units

The front-end units convert a mains AC voltage and current into a DC voltage and current. The power is transferred from the mains to a common DC bus (and, in certain cases, vice versa).

The SPA (active front-end) unit is a bidirectional (regenerative) power converter for the front end of a common DC bus drive line up. An external LCL filter is used at the input. This unit is suitable in applications where low mains harmonics are required.

The SPN (non-regenerative front-end) unit is a unidirectional (motoring) power converter for the front-end of a common DC bus drive line-up. The device operates as a diode bridge using diode/thyristor components. A dedicated external choke is used at the input. The unit has the capacity to charge a common DC bus. This unit is suitable as a rectifying device when a “normal” level of harmonics is accepted and no regeneration to the mains is required.

Inverter Unit

The SPI9000 Inverter Unit is a bidirectional DC-fed power inverter for the supply and control of AC motors. The inverter is supplied from a common DC bus drive line-up. A charging circuit is needed in case a connection to a live DC bus is required. The DC side charging circuit is integrated up to 75 kW (FR4–FR8) and external for higher power ratings (F19–F114).

Application Description

The common DC bus product portfolio fulfills all solution demands with a flexible architecture.

Front end units are selected according to the level of harmonics and power requirements. Typical drive system configurations are illustrated the following figures.

SPA + Inverters

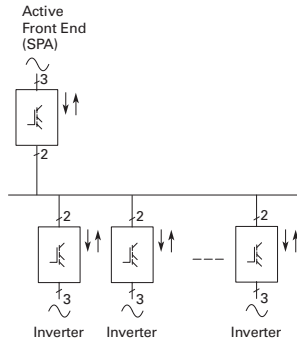

- Low harmonics, $-P_{\text{mains}} \approx +P_{\text{mains}}/P_{\text{mains}} \leq \Sigma P_{\text{INU}}$
- Suitable for almost every application

SPN + Inverters

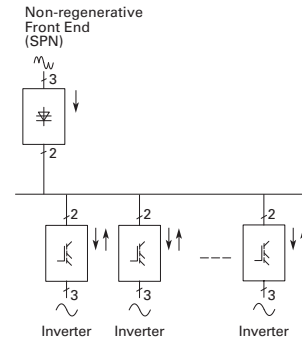

- Low total mains power, $P_{\text{mains}} \leq \Sigma P_{\text{INU}}$
- Suitable e.g. for small processing line with un- and recoiler, em-stop coasting

Combination Configuration

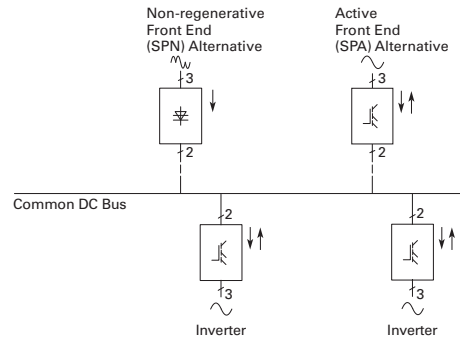

Common DC bus components are used in a multitude of combinations. Drives which are braking can transfer the energy directly to the drives in motoring mode.

Product Comparison

Advantages over Conventional Front Ends

Eaton Front Ends vs. Conventional

	Non-Regenerative Front End	Active Front End	Conventional Regenerative Front End ①
Input device	Choke (L)	Filter (LCL)	Choke or auto-transformer (L)
Bridge type	Diode/thyristor bridge	IGBT bridge, two-level type	Anti-parallel connected thyristor bridge
Type of operation	Controlled half-bridge	High frequency modulation (1.5 to 3.6 kHz)	Firing angle controlled
Direction of power	Motoring	Motoring and regenerating	Motoring and regenerating
Charging	Constant current	External required	Usually internal
DC voltage	Nominal (approx. 1.35 alternative U_N)	Stable at +10% of nominal (approx. 110% of 1.35 alternative U_N)	Lowered DC voltage for commutation margin (e.g. 17% if approx. 83% of 1.35 alternative U_N) or autotransformer on regenerative bridge
THD	Similar to six-pulse bridge normal <40%	Very low	Similar to six-pulse bridge or worse

Note

① Conventional regenerative front end (a.k.a. "anti-parallel thyristor bridge") is not available from Eaton.

2.10

Adjustable Frequency Drives

SPA9000/SPN9000/SPI9000 Common DC Bus Drives

Features

2

Standard Features

Feature	SPI9000		SPA		SPN
	FR4, 6, 7	FR8	FI9-F114	FI9-F114	FI9
IP00	—	■	■	■	■
IP21	■	—	—	—	—
Air cooling	■	■	■	■	■
Standard board	■	■	■	■	—
Varnished board	—	—	—	—	—
Alphanumeric keypad	■	■	■	■	—
EMC class T (EN 61800-3 for IT networks)	■	■	■	■	■
Safety CE/UL	■	■	■	■	■
Input choke	—	—	—	—	■
LCL filter	—	—	—	■	—
No integrated charging	—	—	■	■	—
Integrated charging (DC side)	■	■	—	—	■
Diode/thyristor rectifier	—	—	—	—	■
IGBT	■	■	■	■	—

Standards and Certifications

- CE
- UL
- cUL
- EN 61800-5-1 (2003)



Catalog Number Selection

Active Front End

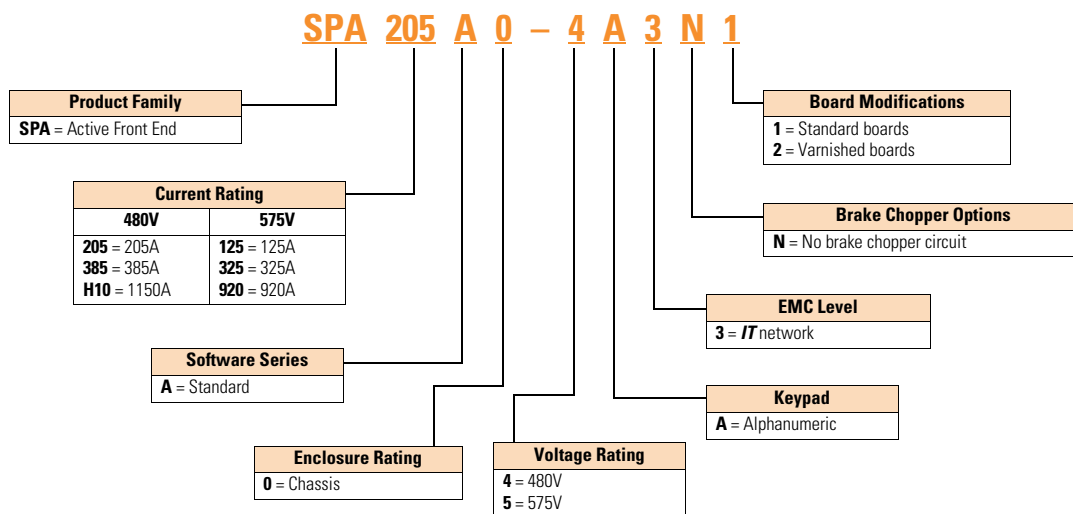

Non-Regenerative Front End

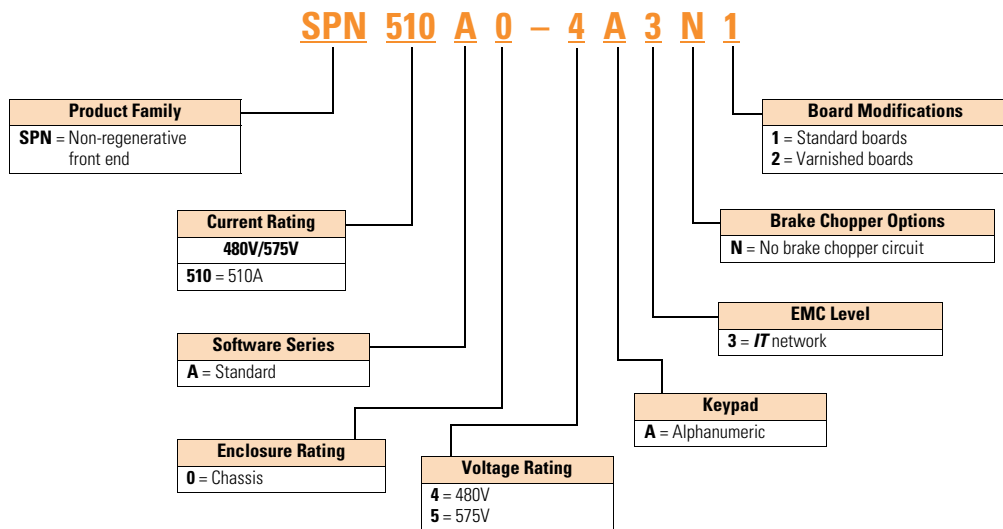

SPI9000 Inverter Unit

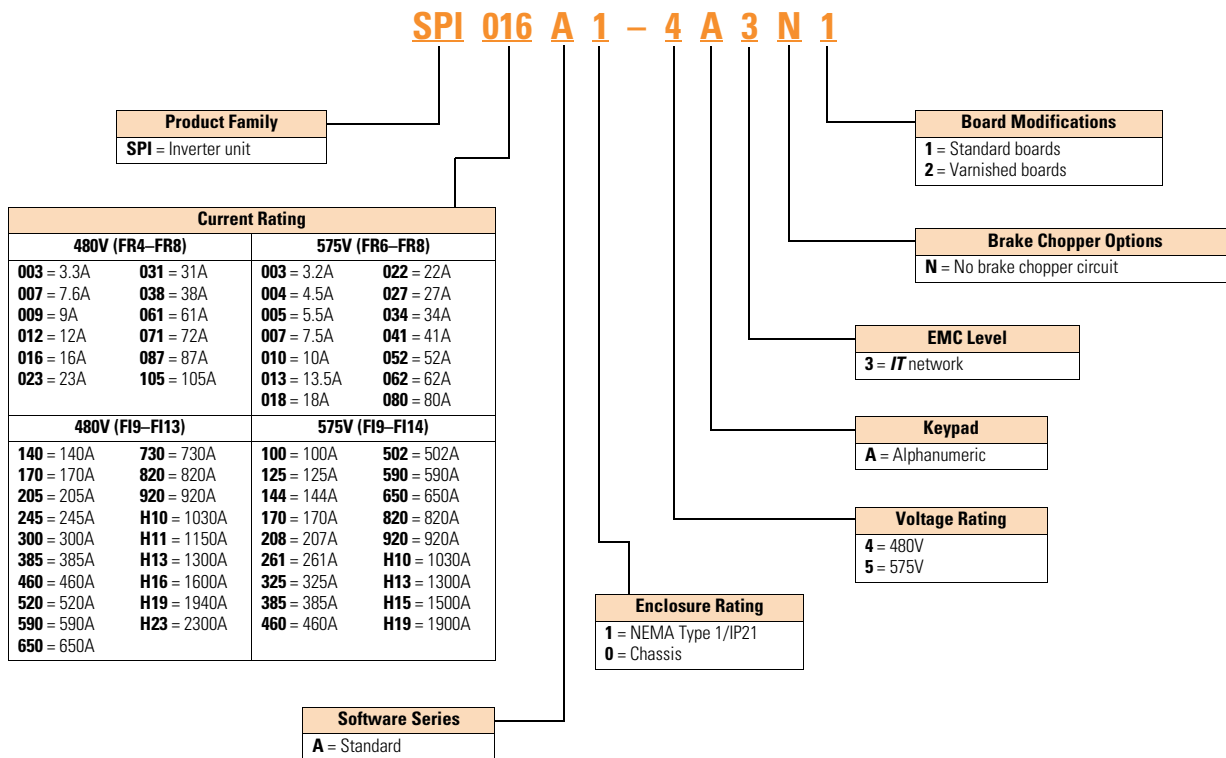

Product Selection

2

Common DC Bus Drive
Products

SPA9000 Active Front End 480V

Frame	Low Overload (AC Current)		High Overload (AC Current)		I _{max} I _{2s} (A)	Catalog Number
	I _{L-cont} (A)	I _{1min} (A)	I _{H-cont} (A)	I _{1min} (A)		
FI9	261	287	205	308	349	SPA205A0-4A3N1
FI10	460	506	385	578	693	SPA385A0-4A3N1
FI13	1300	1430	1150	1725	2070	SPAH11A0-4A3N1

SPN9000 Non-Regenerative Front End 480V

Frame	Low Overload (AC Current)		High Overload (AC Current)		I _{max} I _{2s} (A)	Catalog Number
	I _{L-cont} (A)	I _{1min} (A)	I _{H-cont} (A)	I _{1min} (A)		
FI9	520	572	460	690	828	SPN460A0-4A3N1

SPI9000 Inverter Unit 480V

Frame	Low Overload (AC Current)		High Overload (AC Current)		I _{max} I _{2s} (A)	Catalog Number
	I _{L-cont} (A)	I _{1min} (A)	I _{H-cont} (A)	I _{1min} (A)		
FR4	4.3	4.7	3.3	5	6.2	SPI003A1-4A3N1
	9	9.9	7.6	11.4	14	SPI007A1-4A3N1
	12	13.2	9	13.5	18	SPI009A1-4A3N1
FR6	16	17.6	12	18	24	SPI012A1-4A3N1
	23	25.3	16	24	32	SPI016A1-4A3N1
	31	34	23	35	46	SPI023A1-4A3N1
	38	42	31	47	62	SPI031A1-4A3N1
	46	51	38	57	76	SPI038A1-4A3N1
FR7	72	79	61	92	122	SPI061A1-4A3N1
	87	96	72	108	144	SPI072A1-4A3N1
	105	116	87	131	174	SPI087A1-4A3N1
FR8	140	154	105	158	210	SPI105A0-4A3N1
FI9	170	187	140	210	280	SPI140A0-4A3N1
	205	226	170	255	336	SPI170A0-4A3N1
	261	287	205	308	349	SPI205A0-4A3N1
	300	330	245	379	444	SPI245A0-4A3N1
FI10	385	424	300	450	540	SPI300A0-4A3N1
	460	506	385	578	693	SPI385A0-4A3N1
	520	572	460	690	828	SPI460A0-4A3N1
FI12	590	649	520	780	936	SPI520A0-4A3N1
	650	715	590	885	1062	SPI590A0-4A3N1
	730	803	650	975	1170	SPI650A0-4A3N1
	820	902	730	1095	1314	SPI730A0-4A3N1
	920	1012	820	1230	1476	SPI820A0-4A3N1
FI13	1030	1133	920	1380	1656	SPI920A0-4A3N1
	1150	1265	1030	1545	1854	SPIH10A0-4A3N1
	1300	1430	1150	1720	2070	SPIH11A0-4A3N1
FI14	1450	1595	1300	1950	2340	SPIH13A0-4A3N1
	1770	1947	1600	2400	2880	SPIH16A0-4A3N1
	2150	2365	1940	2910	3492	SPIH19A0-4A3N1

NoteFor filter and line reactor information, see [Page V6-T2-286](#).

Common DC Bus Drive Products



SPA9000 Active Front End 575V

Frame	Low Overload (AC Current)		High Overload (AC Current)		I _{max}	Catalog Number
	I _{L-cont} (A)	I _{1min} (A)	I _{H-cont} (A)	I _{1min} (A)	I _{2s} (A)	
FI9	144	158	125	188	213	SPA125A0-5A3N1
FI10	385	424	325	488	585	SPA325A0-5A3N1
FI13	1030	1133	920	1380	1656	SPA920A0-5A3N1

SPN9000 Non-Regenerative Front End 575V

Frame	Low Overload (AC Current)		High Overload (AC Current)		I _{max}	Catalog Number
	I _{L-cont} (A)	I _{1min} (A)	I _{H-cont} (A)	I _{1min} (A)	I _{2s} (A)	
FI9	600	660	510	732	888	SPN510A0-5A3N1

SPI9000 Inverter Unit 575V

Frame	Low Overload (AC Current)		High Overload (AC Current)		I _{max}	Catalog Number
	I _{L-cont} (A)	I _{1min} (A)	I _{H-cont} (A)	I _{1min} (A)	I _{2s} (A)	
FR6	4.5	5	3.2	5	6.4	SPI003A1-5A3N1
	5.5	6	4.5	7	9	SPI004A1-5A3N1
	7.5	8	5.5	8	11	SPI005A1-5A3N1
	10	11	7.5	11	15	SPI007A1-5A3N1
	13.5	15	10	15	20	SPI010A1-5A3N1
	18	20	13.5	20	27	SPI013A1-5A3N1
	22	24	18	27	36	SPI018A1-5A3N1
	27	30	22	33	44	SPI022A1-5A3N1
FR7	34	37	27	41	54	SPI027A1-5A3N1
	41	45	34	51	68	SPI034A1-5A3N1
FR8	52	57	41	62	82	SPI041A1-5A3N1
	62	68	52	78	104	SPI052A0-5A3N1
FR8	80	88	62	93	124	SPI062A0-5A3N1
	100	110	80	120	160	SPI080A0-5A3N1
	125	138	100	150	200	SPI100A0-5A3N1
FI9	144	158	125	188	213	SPI125A0-5A3N1
	170	187	144	216	245	SPI144A0-5A3N1
	208	229	170	255	289	SPI170A0-5A3N1
	261	287	208	312	375	SPI208A0-5A3N1
FI10	325	358	261	392	470	SPI261A0-5A3N1
	385	424	325	488	585	SPI325A0-5A3N1
	460	506	385	578	693	SPI385A0-5A3N1
FI12	502	552	460	690	828	SPI460A0-5A3N1
	590	649	502	753	904	SPI502A0-5A3N1
	650	715	590	885	1062	SPI590A0-5A3N1
	750	825	650	975	1170	SPI650A0-5A3N1
	920	1012	820	1230	1476	SPI820A0-5A3N1
FI13	1030	1133	920	1380	1656	SPI920A0-5A3N1
	1180	1298	1030	1464	1755	SPIH10A0-5A3N1
	1500	1650	1300	1950	2340	SPIH13A0-5A3N1
FI14	1900	2090	1500	2250	2700	SPIH15A0-5A3N1
	2250	2475	1900	2782	3335	SPIH19A0-5A3N1

NoteFor filter and line reactor information, see [Page V6-T2-286](#).

LCL Filters

2

LCL Filters for Active Front End (480V)

Amps	Catalog Number	Amps	Catalog Number
10	REG 10 5 0	270	REG 270 5 0
18	REG 18 5 0	410	REG 410 5 0
32	REG 32 5 0	580	REG 580 5 0
48	REG 48 5 0	840	REG 840 5 0
75	REG 75 5 0	1160	REG 1160 5 0
110	REG 110 5 0	1480	REG 1480 5 0
180	REG 180 5 0		

LCL Filters for Active Front End (690V)

Amps	Catalog Number	Amps	Catalog Number
14	REG 14 6 0	287	REG 287 6 0
23	REG 23 6 0	390	REG 390 6 0
35	REG 35 6 0	460	REG 460 6 0
52	REG 52 6 0	620	REG 620 6 0
85	REG 85 6 0	780	REG 780 6 0
122	REG 122 6 0	920	REG 920 6 0
185	REG 185 6 0	1180	REG 1180 6 0

Line Reactor

Line Reactor for Non-Regenerative Front End (480/575VV)

Amps	Watts Losses	Catalog Number
600	493	CHK600

Options

9000X Series Option Board Kits

The 9000X Series drives can accommodate a wide selection of expander and adapter option boards to customize the drive for your application needs. The drive's control unit is designed to accept a total of five option boards.

The 9000X Series factory installed standard board configuration includes an A9 I/O board and an A2 relay output board, which are installed in slots A and B.

Option Boards

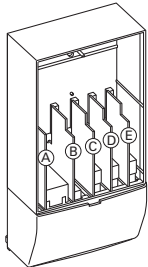

Option Board Kits

Option Kit Description ^①	Allowed Slot Locations ^②	Field Installed Catalog Number	Factory Installed Option Designator	SVX Ready Programs						
				Basic	Local/Remote	Standard	MSS	PID	Multi-P.	PFC
Standard I/O Cards										
2 RO (NC-NO)	B	OPTA2	—	■	■	■	■	■	■	■
6 DI, 1 DO, 2 AI, 1 AO, 1 +10 Vdc ref, 2 ext +24 Vdc/EXT +24 Vdc	A	OPTA9	—	■	■	■	■	■	■	■
Extended I/O Cards										
2 RO, therm	B	OPTA3	A3	—	■	■	■	■	■	■
Encoder low volt +5V/15V/24V	C	OPTA4	A4	—	■	■	■	■	■	■
Encoder high volt +15V/24V	C	OPTA5	A5	—	■	■	■	■	■	■
Double encoder	C	OPTA7	A7	■	■	■	■	■	■	■
6 DI, 1 DO, 2 AI, 1 AO	A	OPTA8	A8	—	■	■	■	■	■	■
3 DI (encoder 10–24V), out +15V/+24V, 2 DO (pulse+direction)	C	OPTAE	AE	■	■	■	■	■	■	■
6 DI, 1 ext +24 Vdc/EXT +24 Vdc	B, C, D , E	OPTB1	B1	—	—	—	—	—	■	■
1 RO (NC-NO), 1 RO (NO), 1 therm	B, C, D , E	OPTB2	B2	—	—	—	—	—	■	■
1 AI (mA isolated), 2 AO (mA isolated), 1 ext +24 Vdc/EXT +24 Vdc	B, C, D , E	OPTB4	B4	—	■	■	■	■	■	■
3 RO (NO)	B, C, D , E	OPTB5	B5	—	—	—	—	—	■	■
1 ext +24 Vdc/EXT +24 Vdc, 3 Pt100	B, C, D , E	OPTB8	B8	—	—	—	—	—	—	—
1 RO (NO), 5 DI 42–240 Vac input	B, C, D , E	OPTB9	B9	—	—	—	—	—	■	■
SPI, absolute encoder	C	OPTBB	BB	—	—	—	—	—	—	—
Communication Cards ^③										
Modbus	D, E	OPTC2	C2	■	■	■	■	■	■	■
Johnson Controls N2	D, E	OPTC2	CA	—	—	—	—	—	—	—
Modbus TCP	D, E	OPTC1	C1	■	■	■	■	■	■	■
BACnet	D, E	OPTCJ	CJ	■	■	■	■	■	■	■
EtherNet/IP	D, E	OPTCQ	CQ	■	■	■	■	■	■	■
PROFIBUS DP	D, E	OPTC3	C3	■	■	■	■	■	■	■
LonWorks	D, E	OPTC4	C4	■	■	■	■	■	■	■
PROFIBUS DP (D9 connector)	D, E	OPTC5	C5	■	■	■	■	■	■	■
CANopen (slave)	D, E	OPTC6	C6	■	■	■	■	■	■	■
DeviceNet	D, E	OPTC7	C7	■	■	■	■	■	■	■
Modbus (D9 type connector)	D, E	OPTC8	C8	■	■	■	■	■	■	■
Adapter	D, E	OPTD1	D1	■	■	■	■	■	■	■
Adapter	D, E	OPTD2	D2	■	■	■	■	■	■	■
RS-232 with D9 connection	D, E	OPTD3	D3	■	■	■	■	■	■	■
Keypad										
9000X Series local/remote keypad (replacement keypad)	—	KEYPAD-LOC/REM	—	—	—	—	—	—	—	■
9000X Series remote mount keypad unit (keypad not included, includes 10 ft cable, keypad holder, mounting hardware)	—	OPTRMT-KIT-9000X	—	—	—	—	—	—	—	—
9000X Series RS-232 cable, 13 ft	—	PP00104	—	—	—	—	—	—	—	—

Notes

① AI = Analog Input; AO = Analog Output, DI = Digital Input, DO = Digital Output, RO = Relay Output

② Option card must be installed in one of the slots listed for that card. Slot indicated in bold is the preferred location.

③ OPTC2 is a multi-protocol option card.

Technical Data and Specifications

2

SPA9000/SPN9000/SPI9000

Description	Specification
Supply Connection	
Input voltage U_{in} (AC) front end modules	380–500 Vac/525–690 Vac –10% to 10%
Input voltage U_{in} (DC) inverter	465–800 Vdc/640–1100 Vdc –0% to 0%, the waviness of the inverter supply voltage, formed in rectification of the electric network's alternating voltage in basic frequency, must be less than 50V peak-to-peak
Output voltage U_{out} (AC) inverter	$3 \sim 0 - U_{in}/1.4$
Output voltage U_{out} (DC) active front end module	$10.10 \times 1.35 \times U_{in}$ (factory default)
Output voltage U_{out} (DC) non-regenerative front end module	$1.35 \times U_{in}$
Ambient Conditions	
Ambient operating temperature	14 (no frost) to 122°F (–10 to 50°C): I_H 14 (no frost) to 104°F (–10 to 40°C): I_L
Storage temperature	–40 to 158°F (–40 to 70°C)
Relative humidity	0 to 95% RH, non-condensing, non-corrosive, no dripping water
Air quality	
Chemical vapors	IEC 721-3-3, unit in operation, class 3C2
Mechanical particles	IEC 721-3-3, unit in operation, class 3S2
Altitude	100% load capacity (no derating) up to 1000m 1% derating for each 100m above 1000m; max. 3000m
Vibration	5–150 Hz
EN50178/EN60068-2-6	Displacement amplitude 0.25 mm (peak) at 3–15.8 Hz Max acceleration amplitude 1G at 15.8–150 Hz
Shock EN50178, EN60068-2-27	UPS Drop Test (for applicable UPS weights) Storage and shipping: max 15G, 11 ms (in package)
Cooling capacity required	Approximately 2%
Cooling air required	FR4 41 cfm, FR6 250 cfm, FR7 250 cfm, FR8 383 cfm FR9 677 cfm, FR10 824 cfm, FR12 1648 cfm, FR13 2472 cfm
Unit enclosure class	FR4–FR7 NEMA Type 1/IP21; FR8, FR9–FR14 chassis (IP00)
EMC (at fault settings)	
Immunity	Fulfill all EMC immunity requirements
Safety	
Approvals	CE, UL, cUL, EN 61800-5-1 (2003), see unit nameplate for more detailed approvals
Control Connections	
Analog input voltage	0–10V, $R_i = 200$ kohms, (–10V to 10V joystick control) Resolution 0.1%, accuracy $\pm 1\%$
Analog input current	0(4)–20 mA, $R_i = 250$ ohms differential
Digital inputs	6, positive or negative logic; 18–30 Vdc
Auxiliary voltage	+24V, $\pm 15\%$, max. 250 mA
Output reference voltage	+10V, +3%, max. load 10 mA
Analog output	0(4)–20 mA; RL max. 500 ohms; resolution 10 bits Accuracy $\pm 2\%$
Digital outputs	Open collector output, 50 mA/48V
Relay outputs	2 programmable change-over relay outputs Switching capacity: 24 Vdc/8A, 250 Vac/8A, 125 Vdc/0.4A Min. switching load: 5V/10 mA

SPA9000/SPN9000/SPI9000, continued

Description	Specification
Protections	
Overvoltage protection	480V/911 Vdc, 575V/1200 Vdc
Undervoltage protection	480V/333 Vdc, 575V/460 Vdc
Ground fault protection	In case of ground fault in motor or motor cable, only the inverter is protected
Motor phase supervision	Trips if any of the output phases is missing
Overcurrent protection	Yes
Unit overtemperature protection	Yes
Motor overload protection	Yes
Motor stall protection	Yes
Motor underload protection	Yes
Short-circuit protection of 24V and 10V reference voltages	Yes

Input Fuses

SHT fuses can be assembled into same-size DIN fuse base.

SPA9000/SPN9000/SPI9000

Module Component	Frame	Bussman Fuse Type (aR)	Size	U _N (V)	I _N (A)	Qty.
Inverter Units						
SPI003A1-4	FR4	170M1560	0	690	20	2
SPI007A1-4	FR4	170M1562	0	690	63	2
SPI009A1-4	FR4	170M1562	0	690	63	2
SPI012A1-4	FR6	170M1565	0	690	63	2
SPI016A1-4	FR6	170M1565	0	690	63	2
SPI023A1-4	FR6	170M1565	0	690	63	2
SPI031A1-4	FR6	170M1567	0	690	100	2
SPI038A1-4	FR6	170M1567	0	690	100	2
SPI061A1-4	FR7	170M1570	0	690	200	2
SPI072A1-4	FR7	170M1570	0	690	200	2
SPI087A1-4	FR7	170M1571	0	690	250	2
SPI105A0-4	FR8	170M3819	DIN1	690	400	2
SPI140A0-4	FR8	170M3819	DIN1	690	400	2
SPI170A0-4	FR8	170M3819	DIN1	690	400	2
SPI205A0-4	FI9	170M6812	DIN3	690	800	2
SPI245A0-4	FI9	170M6812	DIN3	690	800	2
SPI300A0-4	FI10	170M8547	3SHT	690	1250	2
SPI385A0-4	FI10	170M8547	3SHT	690	1250	2
SPI460A0-4	FI10	170M8547	3SHT	690	1250	2
SPI520A0-4	FI12	170M8547	3SHT	690	1250	2 x 2
SPI590A0-4	FI12	170M8547	3SHT	690	1250	2 x 2
SPI650A0-4	FI12	170M8547	3SHT	690	1250	2 x 2
SPI730A0-4	FI12	170M8547	3SHT	690	1250	2 x 2
SPI820A0-4	FI12	170M8547	3SHT	690	1250	2 x 2
SPI920A0-4	FI12	170M8547	3SHT	690	1250	2 x 2
SPIH10A0-4	FI13	170M8547	3SHT	690	1250	6
SPIH11A0-4	FI13	170M8547	3SHT	690	1250	6
SPIH13A0-4	FI13	170M8547	3SHT	690	1250	6
SPIH16A0-4	FI14	170M8547	3SHT	690	1250	2 x 6
SPIH19A0-4	FI14	170M8547	3SHT	690	1250	2 x 6
SPIH23A0-4	FI14	170M8547	3SHT	690	1250	2 x 6

2.10

Adjustable Frequency Drives

SPA9000/SPN9000/SPI9000 Common DC Bus Drives

SHT fuses can be assembled into same-size DIN fuse base.

SPA9000/SPN9000/SPI9000, continued

2

Module Component	Frame	Bussman Fuse Type (aR)	Size	U_N (V)	I_N (A)	Qty.
Active Front Ends						
SPA205A0-4	FI9	170M6202	3SHT	1250	500	3
SPA385A0-4	FI10	170M6277	3SHT	1250	1000	3
SPAH10A0-4	FI13	170M6277	3SHT	1250	1000	3 x 3
Non-Regenerative Front Ends						
SPN468A0-4	FI9	170M8547	3SHT	690	1250	3

Wiring Diagrams

SPA9000—Active Front End

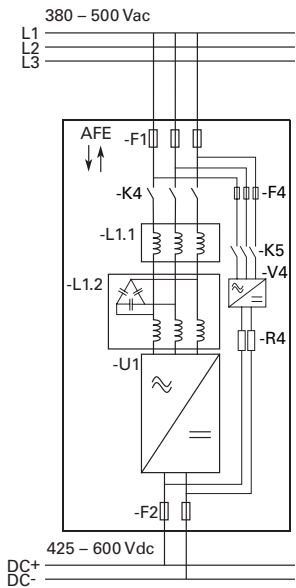

SPN9000—Non-Regenerative Front End

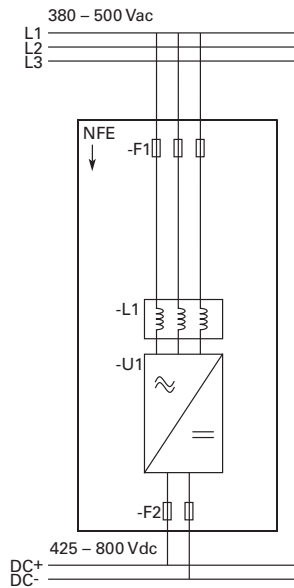

SPI9000—Inverter Unit (FR4–FR8)

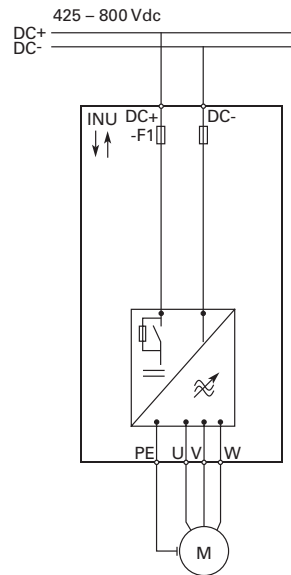

SPI9000—Inverter Unit (FI9–FI14)

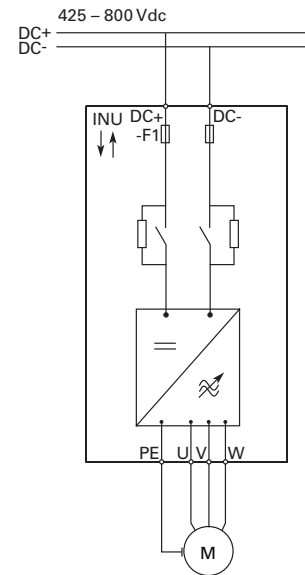

Dimensions

Approximate Dimensions in Inches (mm)

SPA9000/SPN9000/SPI9000

Frame	Height	Width	Depth	Weight Lbs (kg)
Active Front Ends				
FI9	40.6 (1030)	9.4 (239)	14.6 (372)	148 (67)
FI10	40.6 (1032)	9.4 (239)	21.7 (552)	220 (100)
FI12	40.6 (1032)	2 x 9.4 (2 x 239)	21.7 (552)	441 (200)
FI13	40.6 (1032)	27.9 (708)	21.8 (553)	674 (306)
FI14	40.6 (1032)	2 x 27.9 (2 x 708)	21.8 (553)	1348 (612)
Non-Regenerative Front Ends				
FI9	40.6 (1030)	9.4 (239)	14.6 (372)	148 (67)
Inverter Units				
FR4	11.5 (292)	5.0 (128)	7.5 (190)	11 (5)
FR6	20.4 (519)	7.7 (195)	9.3 (237)	35 (16)
FR7	23.3 (591)	9.3 (237)	10.1 (257)	64 (29)
FR8	29.8 (758)	11.4 (289)	13.5 (344)	106 (48)
FI9	40.6 (1030)	9.4 (239)	14.6 (372)	148 (67)
FI10	40.6 (1032)	9.4 (239)	21.7 (552)	220 (100)
FI12	40.6 (1032)	2 x 9.4 (2 x 239)	21.7 (552)	441 (200)
FI13	40.6 (1032)	27.9 (708)	21.8 (553)	674 (306)
FI14	40.6 (1032)	2 x 27.9 (2 x 708)	21.8 (553)	1348 (612)