

Vigirex™ Ground-Fault Relays

April

04

Class 0972



CONTENTS

Description	Page
Introduction	3
Vigirex Ground-Fault Relays System Overview	7
Relay Characteristics	13
Sensors	23
Coordination	29
Application	31
Installation and Dimensions	39
Definitions	49

PLEASE NOTE

Electrical equipment should be installed, operated, serviced, and maintained only by qualified personnel. No responsibility is assumed by Schneider Electric for any consequences arising out of the use of this material.

SECTION 1—INTRODUCTION

VIGIREX™ GROUND-FAULT RELAYS WITH SEPARATE TOROIDS

Overview



Vigirex RH99M Ground-Fault Relay

The purpose of ground-fault protection is to measure the ground leakage current of an electrical installation, or part of an installation, and interrupt the power supply if the ground-fault current becomes dangerous to property.

Vigirex™ ground-fault relays, with associated sensors (current transformers), measure the leakage current in an electrical installation to detect levels that may be damaging. When used for protection, they cause an associated circuit breaker or switch to interrupt the supply of power to the protected system. They may also be used for monitoring only, with output to an alarm.

The Vigirex product line can be used with loads up to 3200 A. It includes fixed sensitivities from 30 mA to 1 A and adjustable sensitivities up to 30 A, providing a solution that offers both flexibility and performance.

The choice of the right Vigirex relay model for a given application depends on the type of protection required:

- Protection against equipment damage
- Protection against fire hazards
- Motor protection

These types of protection are covered by standards and correspond to different current thresholds and time delays on the products.

Characteristics

- UL 1053 Listed
- For currents up to 3200 A (depending on sensor)
- Sensitivities from 30 mA to 30 A
- Control power from 12 Vdc to 220 AC
- Ideal for protection or alarming
- Immunity to nuisance tripping
- Continuous self-monitoring of the detection circuit
- Operation under all unbalanced phase conditions (in solidly-grounded systems)
- Status indicators:
 - red LED: fault
 - green LED: relay is operational
- Allows coordination over several levels so that only the faulty circuit is shut down
- Test with or without trip of relay
- Modular case, 54 mm wide (DIN rail mount) or 72 mm (panel mount)
- Horizontal or vertical flush or surface mounting on a symmetrical DIN rail
- Automatic or remote reset (depending on model)

Vigirex System Catalog

Section 1—Introduction

Operation

Vigirex relays are designed for use on low-voltage AC installations. When the leakage current detected by the sensor exceeds a certain threshold, referred to as the “threshold leakage current $I_{\Delta n}$ ”, the Vigirex relay trips the associated circuit breaker via a shunt trip or under-voltage release on the circuit breaker. The control signal issued by the relay may be instantaneous or delayed. Depending on the model, the operating thresholds and time delays may or may not be adjustable.

Vigirex relays can be used at all levels of an installation: power distribution, industrial control and final distribution, as well as with a variety of OEM equipment. They are designed for AC installations implementing a variety of solidly-grounded arrangements and are suitable to monitor voltages up to 600 Vac and frequencies ranging from 50/60 Hz and 400 Hz.

Function

Vigirex relays measure the earth-leakage current in an electrical installation via their associated sensors. The relays can be used in the following ways:

- Ground-fault protection (RH10, RH21, RH99 with manual reset)
- Earth-leakage alarming (same models, plus RH99 with automatic reset)

Ground-Fault Protection

In protection applications, the relays control the interruption of the supply of power to protect:

- equipment and property against fire; and
- equipment against damage from high ground-fault currents.

A relay trips the associated circuit breaker when the threshold operating current $I_{\Delta n}$ is exceeded. Depending on the model of the relay, the threshold $I_{\Delta n}$ can be fixed or user-selectable. Circuit breaker tripping can be either instantaneous or delayed. On some Vigirex relays, it is possible to adjust the time delay.

The protection relays “latch” the output contacts until the output contact has been manually reset. Once the fault has been cleared the relay can be used again. The exception is the group of RH99 relays with automatic reset.

Earth-Leakage Monitoring (Alarming)

Vigirex relays may also be used to monitor earth-leakage in electrical insulation due to aging of cables or extensions in the installation. Continuous measurement of leakage currents makes it possible to plan maintenance on faulty circuits before an increase in the leakage currents leads to a complete shutdown of the installation.

In alarming applications, the output contacts are connected to a warning light, SCADA system, or other annunciator device. A control signal is issued by the relay when the threshold is overrun. The control signal can be either instantaneous or delayed. On some relays, it is possible to adjust the time delay. Some models of the RH99 Vigirex relays do not latch their output contact and they are automatically reset when the fault is cleared.

It is possible to configure a system to provide both alarming and protection. In that case, one Vigirex ground-fault relay is set to a low sensitivity to alarm when insulation is faulty but still operable, and a second Vigirex ground-fault relay is set to interrupt the circuit when the ground-fault level becomes hazardous.

APPLICATION EXAMPLES

Figure 1: Types of Protection

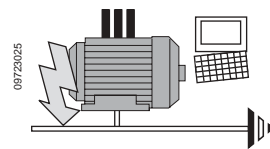

Protection of electronics*

e.g.: $I\Delta n = 30 \text{ mA}$ instantaneous

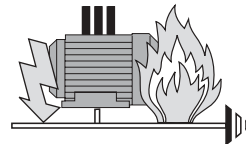

Protection against fire hazards

e.g.: $I\Delta n = 300 \text{ mA}$
90 ms time delay

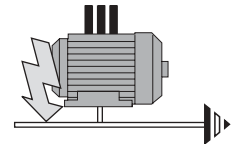

Protection of property (motors, etc)

e.g.: $I\Delta n = 3 \text{ A}$
250 ms time delay

*Depending on the opening time of the circuit breaker or associated contactor

OPTIMIZED PROTECTION AND CONTINUITY OF SERVICE

The design of the Vigirex relay includes several functions that minimize the risk of nuisance tripping. Rms measurement of ground-fault currents, frequency filtering, reduced tolerances on the protection threshold and the inverse-time tripping curve built into the Vigirex relay optimize protection of property and enhance continuity of service.

Continuous Self-Monitoring of Vigirex Relays

Vigirex relays carry out continuous self-monitoring of key relay functions, including:

- Internal electronics
- Power supply
- Relay / sensor link (and the sensor itself)

When the relay detects a problem, the fault or the ON output contact on the relay is actuated. The cause of the internal problem must be cleared before the relay can continue its functions.

Sensors

Vigirex relays are used with closed (type A, diameter 30–300 mm) or split (type OA, diameter 46–110 mm) toroids. Additionally, large rectangular sensors are available. All sensors are easy to mount, with a wide range of installation possibilities.

Environmental Characteristics

Vigirex relays are designed for use in ambient temperatures from -31° F to 158° F (-35° C to 70° C). The temperature range for device storage, in the original packing, is -67° F to 185° F (-55° C to 85° C).

Vigirex relays comply with the environmental requirements contained in the following standards:

- IEC 60068-2-30 and IEC 60068-2-56: damp heat
- IEC 60068-2-52: salt mist

Vigirex relays are certified for operation in pollution degree III environments, as defined by IEC 60664-1 and IEC 60947-1 for low-voltage switchgear.

Vigirex System Catalog

Section 1—Introduction

Compliance with Standards

Vigirex relays are designed to comply with the following Standards:

- UL 1053
- CSA C22.2 No. 144
- IEC 60 947-2 Appendix B
- IEC 364 Chapter 4 and Chapter 5
- IEC 755
- UTE C 60–130
- VDE 664
- NFC 61–141 ad. 1
- NFC 15–100
- CISPR 11

SECTION 2—VIGIREX GROUND-FAULT RELAYS SYSTEM OVERVIEW

INTRODUCTION

Manufacturers can increase production efficiency and decrease downtime by protecting expensive electrical equipment from ground faults. Schneider Electric / Square D has determined that more than 80% of short circuits are initially manifested as ground faults (also called ground leakage or residual current leakage). Detecting ground faults before they reach hazardous levels helps to avoid damage to equipment. Planned maintenance can be scheduled before expensive damage occurs, thus minimizing downtime.

To help protect equipment and electrical distribution systems from ground faults, Square D offers a line of UL Listed Vigirex Ground-Fault Relays. These are compact electronic devices that are easy to install. The ground-fault relays can be used with most industrial voltages and currents. The specific application will dictate which model needs to be used. This is determined primarily by the level of ground fault current it needs to detect (from a range of 30 mA to 30 A) and the speed with which it should react (from instantaneous to 4.5 seconds of time delay).

Other choices include:

- Panel-mount or DIN-mount installation
- A variety of sensors for a wide range of line voltages and amperages
- A model to operate on the most common power supply voltages
- Outputs for alarming or for protection via shunt trip of a circuit breaker or switch
- Manual reset (for protection) or auto-reset (for alarming)

OPERATION

The Vigirex relays compare outgoing currents with returning currents to determine if there is leakage of current to ground. If there is sufficient ground leakage current, the Vigirex relay will operate its contacts. This can be used for protection by opening the associated disconnect, such as a circuit breaker with shunt trip or under-voltage release (UVR) contacts. Or the contacts can be used to only activate an alarm, such as a warning lamp or input to a SCADA system.

Vigirex ground-fault relays are not designed to protect people as defined by UL 943 Class A. Vigirex relays are designed to meet the UL1053 standard for equipment protection.

Ground-fault relays do not provide overcurrent or short circuit protection. A Vigirex ground-fault system includes these components:

- Vigirex Ground-Fault Relay—This has control power inputs, inputs from the sensor, outputs to the disconnect device, and electronic circuitry that determines if the ground-fault exceeds the trip level.
- Sensor—Current transformer through which the monitored line passes (all phases plus neutral; but not ground wire); its secondary goes to the relay input.
- Disconnect Device or Alarm Annunciator—Output of the Vigirex goes to the protective device such as a switch or circuit breaker with a shunt trip device or to an alarming device like a warning lamp or SCADA system.
- Control Power—The electrical energy needed by the relay must be supplied by a source independent of network voltage.

Vigirex System Catalog

Section 2–Vigirex Ground-Fault Relays System Overview

Figure 2: Vigirex Ground-Fault Protection System

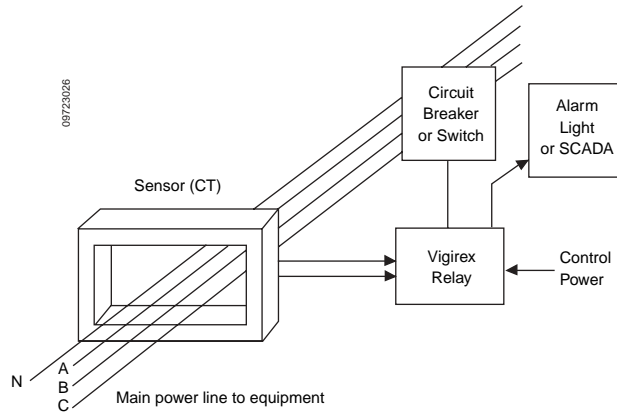

Testing Locally or Remotely, With or Without Tripping

A front-panel test button can be used to test the Vigirex relay, either with or without tripping the disconnect device. This testing can also be done remotely through input terminals on the relay.

BENEFITS TO THE EQUIPMENT USER

The Vigirex relay provides several benefits to the user of electrical equipment:

Table 1: Benefits for the End-Use Customer

Feature	Benefit
Used with circuit breaker or switch to protect equipment from ground-fault	Prevents damage to equipment, reducing down-time and repair costs
Outputs to alarm function	Provides warning that preventive maintenance should be performed on the equipment
Fixed (RH10) or user-settable (RH21 and RH99) sensitivity and time delays	Allows adjustment to balance between nuisance tripping and optimal protection
Frequency filtering and narrow tripping tolerance (between 0.8 and 1 x I Δ n)	Increases immunity to nuisance tripping, resulting in high continuity of service
Local and remote test and reset	Simplifies periodic diagnostics
Test with or without tripping	Allows testing without interruption of service
Electronic technology	High reliability to ensure high availability
Selection of power supplies 12 Vdc–220 Vac	Can use existing line power or control power supplies

Ideally, the Vigirex can be installed in the control panel of a machine when it is manufactured. Alternately, it can be installed by the end-user, either in a machine's control panel or in the feeder or branch circuit supplying the machine.

Vigirex System Catalog

Section 2—Vigirex Ground-Fault Relays System Overview

How can manufacturers be sure equipment has this benefit?

- Purchase only equipment that has adequate ground-fault protection
- Specify it for key custom equipment
- As a last resort, add it to equipment or to the electrical service supplying the equipment

BENEFITS TO THE MANUFACTURER OF EQUIPMENT (OEM)

In addition to the benefits to the end-user, including built-in ground-fault protection also has several benefits for machine manufacturers:

- Provides a better machine for their customers, creating a competitive advantage
- Limits warranty expense by preventing damage to equipment during warranty period
- Ensures that appropriate sensitivity is selected
- The CE mark qualifies equipment for international sales (where ground-fault protection is frequently mandatory).

Table 2: Benefits for the OEM

Feature	Benefit
Protects equipment from ground-faults	Prevents damage to equipment, thus reducing warranty costs
	Increases market value to end-use customer
Small DIN-mount (RHP) or panel-mount (RHM) units	Easy mounting in equipment control panels
Fixed (RH10) or user-settable (RH21 and RH99) sensitivity and time delays with a wide range of pick-up levels	Suitable for most applications
Nine pickup settings and nine time delay settings (RH99)	Can be adapted to specific installation by OEM or end-use customer
Frequency filtering increases immunity to nuisance tripping and gives high continuity of service	Reduces call-backs due to nuisance tripping
Local and remote test and reset	Simplifies diagnostics
Output contacts for up to 6 A	Drives most trip contacts, switch solenoids, or alarm contacts
Selection of power supplies 12 Vdc—220 Vac	Can use line power or control power supplies
Variety of current sensors	Suitable for most loads (amperages) and conductor sizes
UL, IEC with CE mark	Equipment can be sold in many markets

SELECTION CRITERIA FOR RELAYS

Ideal for any machine or branch circuit application, there are a wide variety of Vigirex ground-fault relays. Evaluate the application and select the options that you need, including packaging, supply voltage, sensitivity, and time delays and the ability to reset after a fault. These models are described in more detail below and summarized in Table 3 on page 12.

Mounting / Packaging—RH10M, RH21M, RH99M, and RH10P, RH21P, RH99P

All of the options for Vigirex are available in either of two packages and are identified by the model type:

RH__M DIN-rail Mounting—The RH__M models are compact, non-metallic enclosures with the same universal DIN format and light gray color as Multi 9® miniature circuit breakers. They mount on standard 35 mm DIN rails. Because they measure only 54 mm wide x 88 mm high x 75 mm deep, space can be found in most control panels. All controls and indications are located behind a clear protective door that can be locked for security.

RH__P Panel Mounting—The RH__P models are 72 x 72 mm and can be front-mounted in cut-outs on panels, doors, or front plates using integral mounting clips. The overall depth is 67 mm. These are dark charcoal in color and have a clear protective door that can be locked for security. Integral plug-on connectors are provided for easy connection of all inputs and outputs.

Vigirex System Catalog

Section 2—Vigirex Ground-Fault Relays System Overview

Control Voltage

The Vigirex relays operate with an auxiliary source of power rather than depending on fault power. This means that the relays can be used to monitor low levels of current and can give status even after the monitored circuit is interrupted. Because they only consume four watts of power, the relays cause little drain on a auxiliary power supply.

Three different power supplies are available for the Vigirex relays, depending on the catalog number:

- 12–24 Vac (50/60 Hz) / 12-48 Vdc
- 110–130 Vac (50/60 Hz)
- 220–240 Vac (50/60/400 Hz)

Time Delays

The responsiveness of the Vigirex relay is determined from a combination of their sensitivity (measured in milliamperes or amps) and their time delays (duration that the threshold of ground-fault is exceeded). These can range from instantaneous (no intentional delay) to 4.5 seconds. The shortest delay will provide the greatest protection, while the longest will minimize nuisance tripping. The range of time delays is also helpful when providing a coordinated ground-fault protection scheme.

There are three different groups of Vigirex, based on time delay:

- RH10—Instantaneous (fixed)
- RH21—Instantaneous or 60 milliseconds (two settings)
- RH99—Adjustable from instantaneous to 4.5 seconds (nine settings, including 0.0, 0.06, 0.15, 0.25, 0.31, 0.5, 0.8, 1.0, and 4.5 seconds)

Sensitivity (Tripping Threshold)

The sensitivity of the Vigirex relays determines the level of current leakage to ground at which the relay will operate. Some models can be purchased with a fixed sensitivity, while others are field-selectable. The most sensitive (lowest milliamperage) will provide the greatest protection but have the greatest potential for nuisance tripping. The sensitivity levels include the following:

- RH10—Fixed at 30 mA, 100 mA, 300 mA, 500 mA, or 1 A
- RH21—Selectable between 30 mA or 300 mA (two settings)
- RH99—Adjustable from 30 mA to 30 A (nine settings, including 0.03, 0.1, 0.3, 0.5, 1.0, 3.0, 5.0, 10, and 30 A)

Manual or Automatic Reset

Most Vigirex relays require a manual reset after operating. This is the preferred mode for protection schemes, since it retains the indication that the relay caused tripping of the circuit breaker. For monitoring or alarming applications, it may be desirable to have automatic reset after the current leakage (ground fault) has been cleared. The RH99M and RH99P are available in either a manual reset version or an automatic reset version.

- Manual reset—The only version of RH10 and RH21; available in certain models of RH99
- Automatic reset—Available only in certain models of RH99

Vigirex System Catalog

Section 2–Vigirex Ground-Fault Relays System Overview

SELECTION CRITERIA FOR SENSORS

All current-carrying conductors of the monitored circuit must pass through a Vigirex sensor, which detects the level of residual current in the line. These must include all phases plus neutral.

NOTE: Only Vigirex sensors should be used with Vigirex relays.

Ten different models of sensors (current transformers) are included in the product line. These sensors should be selected primarily based on the maximum current of the monitored line, size of conductors, and mounting considerations. See Table 4 on page 12 for the models available.

Closed Toroid Sensors

The widest range of Vigirex sensors is the closed toroid type. The smaller ones can be clipped directly on to the Vigirex relay or mounted on DIN rail for easy mounting. The sizes and ratings include the following:

- Window diameters from 30 mm (1.18 in.)–300 mm (11.8 in.)
- Current ratings from 65 A–630 A

Split Toroid Sensors

Split toroids are designed to be used in existing installations, as they can be installed without having to disconnect the existing cabling. Two models are available:

- Window diameters of 46 mm (1.81 in.) and 110 mm (4.33 in.)
- Current ratings of 85 A and 250 A

Rectangular Sensors

Rectangular sensors are designed for use with large bus bars and high currents. See Section 4 for details on these sensors. Two models are available:

- 1200 A – 280 x 115 mm (11 x 4.5 in.)
- 1200 and 3200 A – 470 x 160 mm (18.5 x 6.3 in.)

Vigirex System Catalog

Section 2–Vigirex Ground-Fault Relays System Overview

Table 3: Vigirex Ground-Fault Relays (UL 1053)

Model	Delay	Reset	Control / Voltage	Sensitivity	Catalog Number
DIN-Rail Mounted					
RH10M	Instantaneous	Manual	12–24 Vac / 12–48 Vdc	30 mA 100 mA 300 mA 500 mA 1A	56300 56302 56305 56306 56307
			110–130 Vac	30 mA 100 mA 300 mA 500 mA 1A	56320 56322 56325 56326 56327
			220–240 Vac	30 mA 100 mA 300 mA 500 mA 1A	56330 56332 56335 56336 56337
RH21M	Instantaneous or 60 ms (2 settings)	Manual	12–24 Vac / 12–48 Vdc 110–130 Vac 220–240 Vac	30 mA or 300 mA (2 settings)	56360 56362 56363
RH99M	9 user-selectable time delays: 0 sec (instantaneous), 60 ms, 150 ms, 250 ms, 310 ms, 500 ms, 800 ms, 1 s, 4.5 s	Manual	12–24 Vac / 12–48 Vdc 110–130 Vac 220–240 Vac	9 user-selectable thresholds (30 mA to 30 A): 30 mA, 100 mA, 300 mA, 500 mA, 1 A, 3 A, 5 A, 10 A, 30 A	56370 56372 56373
		Automatic	12–24 Vac / 12–48 Vdc 110–130 Vac 220–240 Vac		56390 56392 56393
Panel Mounted					
RH10P	Instantaneous	Manual	12–24 Vac / 12–48 Vdc	30 mA 100 mA 300 mA 500 mA 1A	56400 56402 56405 56406 56407
			110–130 Vac	30 mA 100 mA 300 mA 500 mA 1A	56420 56422 56425 56426 56427
			220–240 Vac	30 mA 100 mA 300 mA 500 mA 1A	56430 56432 56435 56436 56437
RH21P	Instantaneous or 60 mSec (2 settings)	Manual	12–24 Vac / 12–48 Vdc 110–130 Vac 220–240 Vac	30 mA or 300 mA (2 settings)	56460 56462 56463
RH99P	9 user-selectable time delays: 0 sec (instantaneous), 60 ms, 150 ms, 250 ms, 310 ms, 500 ms, 800 ms, 1 s, 4.5 s	Manual	12–24 Vac / 12–48 Vdc 110–130 Vac 220–240 Vac	9 user-selectable thresholds (30 mA to 30 A): 30 mA, 100 mA, 300 mA, 500 mA, 1 A, 3 A, 5 A, 10 A, 30 A	56470 56472 56473
		Automatic	12–24 Vac / 12–48 Vdc 110–130 Vac 220–240 Vac		56490 56492 56493

Table 4: Sensors for Vigirex Ground-Fault Relays

Sensors	Type	Current Rating	Inside Diameter		Catalog Number
			In.	mm	
Closed toroids, type A	TA30	65 A	1.18	30	50437
	PA50	85 A	1.97	50	50438
	IA80	160 A	3.15	80	50439
	MA120	250 A	4.72	120	50440
	SA200	400 A	7.87	200	50441
	GA300	630 A	11.81	300	50442
Split toroids, type OA	POA*	85 A	1.81	46	50485
	GOA*	250 A	4.33	110	50486
Rectangular sensors	280 x 115	1600 A	11.02 x 4.53	280 x 115	56053
	470 x 160	3200 A	18.50 x 6.30	470 x 160	56054

* Not UL Recognized

SECTION 3—RELAY CHARACTERISTICS

OPTIMUM CONTINUITY OF SERVICE

The Vigirex range of ground-fault relays offers multiple setting possibilities that may be used to create many coordination levels, from the feeder circuits to the final circuits in equipment. Correctly setting the Vigirex ensures total discrimination for ground faults in the installation, i.e., only the faulty section is shut down. Elimination of most cases of nuisance tripping by the ground-fault relay ensures both safety and continuity of service, two indispensable features for users.

Provisions to minimize downtime of the Vigirex relay include:

- Reduced tripping tolerances
- Dependable power supply
- Continuous self-monitoring
- Tests with or without tripping of load
- Test and reset of relay

Reduced Tripping Tolerances

The Vigirex relays trip between 80% and 100% of their tripping threshold ($I_{\Delta n}$) thus increasing immunity to nuisance tripping.

Dependable Power Supply

A range of power supplies is available, including a low voltage unit for operation from AC or DC control power sources. These include:

- 12–24 Vac / 12–48 Vdc
- 110–130 Vac
- 220–240 Vac

Voltage-dip withstand capacity: The Vigirex relay will operate correctly at 55% of the rated control power voltage.

Additional standard functions are available to make the protection as dependable as possible:

- Disconnect of the circuit if the relay fails, by using the Normally Closed (NC) output contacts and an undervoltage release (UVR) instead of shunt trip
- A Green Operating (ON) LED provides a local indication that voltage is not present; this status can be provided remotely via the ON contacts

Vigirex relays are not affected by micro-outages lasting less than 60 ms. The maximum break time during micro-outages complies with standard IEC/EN 60947-2.

















Vigirex System Catalog

Section 3—Relay Characteristics

Continuous Self-Monitoring

Vigirex relays continuously monitor the power supply, relay / sensor link and internal electronics. Internally detected faults are signalled and may be used to trip the circuit breaker. The LEDs on the front of the face can also be used to check operation at any time.

Table 5: Test and Reset Functions

LED Status		Meaning
ON (Green)	Fault (Red)	
		Normal operation
		Fault current detected
	  	Faulty sensor
		No power or device not working
		Non-standard operation detected
Legend		
		OFF (O)
		ON (I)
  		Flashing

NOTE: For RH99M models 56390, 56392, and 56393 resetting is automatic.

Tests With or Without Tripping

The Vigirex relay can be manually tested as part of a maintenance routine. This procedure can be performed locally by employing the TEST button, or remotely by using the TEST contacts. The test can be performed without tripping the protection device, to minimize down-time of equipment. Also, the test can include testing of the tripping function of the disconnect device.

Either method can be used locally (with front-panel push buttons) or remotely via the Test and Reset contacts.

Operation in Less Than 50 Milliseconds

If a Vigirex relay with a 30 mA setting is used to shunt trip a Schneider Electric / Square D Compact NS circuit breaker rated up to 630 A, it will clear faults of greater than 5 x I Δ n in less than 50 milliseconds.

REDUCED NUISANCE TRIPPING

The electronic design of the Vigirex relay provides several functions to minimize outages and eliminate unnecessary downtime. These features include:

- Inverse-time tripping curve
- RMS measurements of ground-fault currents
- Frequency and harmonic filtering
- Immunity to electromagnetic disturbances

Inverse-Time Tripping curve

The inverse-time tripping curve of the Vigirex relays (see Figure 3) affects performance in two beneficial ways:

- Protection is optimized because the higher the ground-fault current it detects, the faster the relay will operate;
- Inverse-time tripping also minimizes the potential for nuisance tripping. This is because, if the duration of the ground-fault is very short the current can be relatively high, but the relay will not trip. This inherently helps to avoid nuisance tripping due to electrical noise since it usually exists for a short duration.

Also, when circuits are energized, the inverse-time tripping curve avoids nuisance tripping due to short, transient phase-sequence currents, which are caused by:

- the high transient currents caused by certain loads (motors, LV/LV transformers, etc.) and
- the charging of capacitances between live conductors and earth.

Figure 3: Vigirex Inverse-Time Tripping Curve

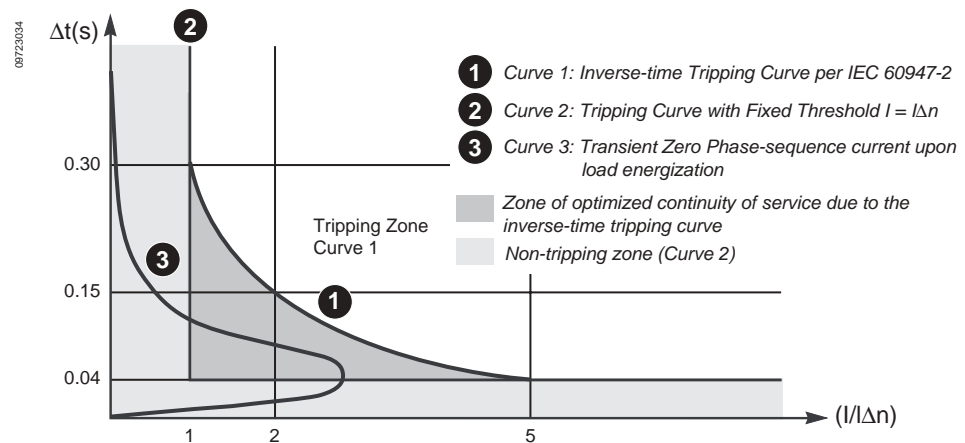

RMS Measurements of Ground-Fault Current

Vigirex devices use rms measurements for the zero-sequence currents. This is the means to:

- accurately measure the harmonic currents and avoid nuisance tripping due to non-dangerous currents with high crest factors; and
- correctly calibrate the energies of the fault currents.

Vigirex System Catalog

Section 3—Relay Characteristics

Frequency Filtering

Frequency filtering by Vigirex residual current relays ensures maximum protection against insulation faults and a particularly high level of continuity of service.

Frequency converters (e.g. variable-speed drives) generate significant levels of high-frequency leakage currents. During normal operation (no fault), these capacitive high-frequency leakage currents flowing in the installation conductors do not represent a danger to equipment.

Figure 4: Frequency Filtering

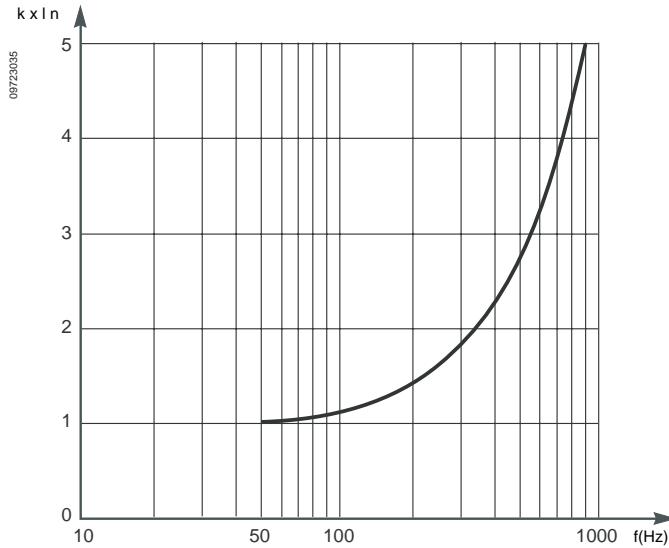

Example

At 50 / 60 Hz, the tripping threshold is I_n .

At 900 Hz, the tripping threshold is $k \times I_n$ (where $k = 5$).

Electromagnetic Disturbances

Vigirex relays are designed to optimize immunity to:

- overvoltages produced by switching (e.g. lighting circuits)
- overvoltages produced by atmospheric disturbances
- radio-frequency waves emitted by devices such as mobile telephones, radio transmitters, two-way radios, radar, etc., and
- electrostatic discharges produced directly by users

To ensure optimal immunity, Vigirex relays are tested in compliance with the following standards:

- IEC/EN 60947-2: low-voltage switchgear and controlgear, Part 2: circuit breakers)
- IEC/EN 61000-4-1: overview of the IEC/EN 61000-4 series
- IEC/EN 61000-4-2: electrostatic-discharge immunity test
- IEC/EN 61000-4-3: radiated, radio-frequency, electromagnetic-field immunity test
- IEC/EN 61000-4-4: electrical fast transient/burst immunity test
- IEC/EN 61000-4-5: surge immunity test
- IEC/EN 61000-4-6: immunity to conducted disturbances, induced by radio frequency fields
- CISPR 22: limits and methods of measurement of electromagnetic disturbance characteristics of industrial, scientific and medical (ISM) radio frequency equipment

The high immunity levels of Vigirex relays ensure optimum safety without nuisance tripping.

Vigirex System Catalog

Section 3—Relay Characteristics

TEST AND RESET OF RELAY

Test

According to the National Electrical Code (NEC), a test is required after installation to check correct operation of the ground-fault relay system.

The purpose of the test is to check:

- the output contacts
 - the complete protection system with actuation of the output contacts (this shuts down the installation)
 - the protection system without actuation of the output contacts ("no trip" test) to maintain the installation up and running.
- correct operation of the LEDs and the internal electronics.

Reset

Whatever the test mode, a reset clears the fault stored in memory and resets the LEDs and the relay status condition.

Table 6: Test and Reset Modes

Pushbutton and Remote Controls	Function
Test	Test with trip (tests relay and protection device or alarm)
Reset	Reset
Both	Test with no trip

Switchboard Acceptance Tests

During acceptance of a switchboard or other electrical equipment and prior to dielectric testing, isolation of the residual-current relays by disconnecting the power supply is mandatory, as shown in Figure 5 below.

Vigirex relays are supplied with a plug-in connector for easy and secure connection and disconnection of control power.

Figure 5: Supply Connections for the DIN and Front-Panel Mount Formats

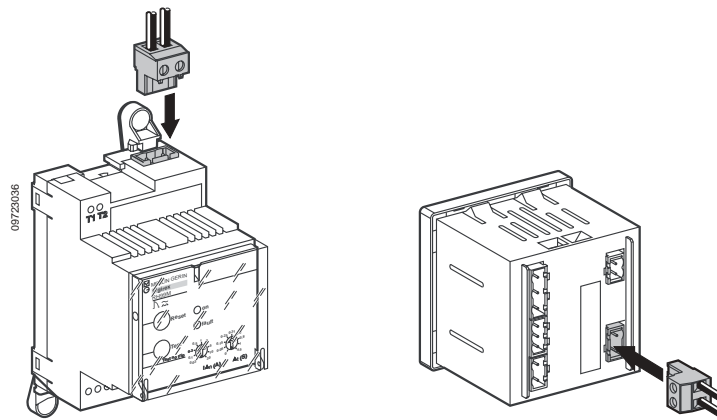

MOUNTING OF VIGIREX RELAYS

The Vigirex relays can be mounted in a variety of ways:

Figure 6: RH Device with Mounting Clips Secured to a Mounting Plate



Figure 7: RH-P Front-Panel Mounted Device



Figure 8: RH-M Device Mounted on a DIN Rail



Figure 9: RH-M with Clip-on Toroid



Plug in connectors allow easy and secure disconnection of control panel for switchboard acceptance dielectric tests.

DIN-format Vigirex relays can be equipped with toroids from 1–2 in. (30–50 mm) in diameter.

Vigirex System Catalog

Section 3—Relay Characteristics

Table 7: Characteristics

Vigirex Relays		RH10	RH21	RH99
General Characteristics				
Monitored Distribution System: LV AC / System Voltage		50/60/400 Hz and up to 600 V		
System Earthing Arrangement		TNS (solidly grounded)		
A, AC type class as per IEC 60947-2		—		
Operating Temperature Range		-31°– +158° F (-35°– +70° C)		
Storage Temperature Range		-67°– +185° F (-55°– +85° C)		
Electrical Characteristics per IEC 60755, IEC 60947-2 and EN 60947-2, and UL 1053				
Power Supply: rated operational voltage U_e	12–24 Vac (55%–120% U_e ¹) 12–48 Vdc	50/60 Hz / DC	—	
	110–130 Vac (55%–110% U_e)	50/60 Hz	—	
	220–240 Vac (55%–110% U_e)	50/60/400 Hz	—	
Rated Impulse Withstand Voltage up to $U_e = 525$ Vac		Uimp (kV)	8	
Maximum Consumption		AC	4 Va	
		DC	4 W	
Inensitive to Micro-outages	<60 ms	—		
Maximum Break Time on Toroid Failure (as per Standard IEC 60947-2)		—		
Fault Current Detection Threshold $I_{\Delta n}$	1 fixed threshold 0.03 A, 0.1 A, 0.3 A, 0.5 A, 1 A		2 user-selectable thresholds 0.03 A or 0.3 A	9 user-selectable thresholds 0.03 A, 0.1 A, 0.3 A, 0.5 A, 1 A, 3 A, 5 A, 10 A, 30 A
	Fault-current Detection Range		74% $I_{\Delta n}$ to 100% $I_{\Delta n}$	
Time Delay Δt	Instantaneous		Instantaneous for $I_{\Delta n} = 0.03$ A Instantaneous or 0.06 s for $I_{\Delta n} = 0.3$ A	9 user-selectable time delays Instantaneous to 4.5 s
Δt Settings	0 s		0 s, 0.06 s	0 s, 0.06 s, 0.15 s, 0.25 s, 0.31 s, 0.5 s, 0.8 s, 1 s, 4.5 s
Maximum Non-operating Time at 2 $I_{\Delta n}$	—		—, 0.06 s	—, 0.06 s, 0.15 s, 0.25 s, 0.31 s, 0.5 s, 0.8 s, 1 s, 4.5 s
Maximum Non-operating Time at 5 $I_{\Delta n}$ (residual-current relay alone)	0.015 s		0.015 s, 0.13 s	0.015 s, 0.13 s, 0.23 s, 0.32 s, 0.39 s, 0.58 s, 0.88 s, 1.08 s, 4.58 s
Maximum Total Time at 5 $I_{\Delta n}$ ²	0.05 s		0.05 s, 0.15 s	0.05 s, 0.15 s, 0.25 s, 0.34 s, 0.41 s, 0.6 s, 0.9 s, 1.1 s, 4.6 s
Setting Switch	none		one	Two selectors: for sensitivity and for time delay
Output Contact	for protection	changeover w/ latching		
	for monitoring	—	—	some models auto-reset
Test with or without actuation of the output contacts and output-contact reset following a fault	Local	—		
	Remote (hard-wired) (10 m max.)	—		
	Remote (hard-wired for several relays) (10 m max.)	—		

¹ 80% to 120% U_e if $U_e < 20$ V

² Maximum time to clear the fault current when a Vigirex relay with a 30 mA setting is used to shunt trip a Schneider Electric / Square D Compact NS circuit breaker rated up to 630 A.

—Continued next page

Vigirex System Catalog Section 3—Relay Characteristics

Table 7: Characteristics

Vigirex Relays		RH10	RH21	RH99
Electrical Characteristics per IEC 60755, IEC 60947-2 and EN 60947-2, and UL 1053				
Self-monitoring	Relay / Sensor Link	Continuous		
	Power Supply			
	Electronics			
Rated Operational Current (A) of Output Contacts	Voltage:	AC	DC-Resistive	DC-Inductive
	24 V	5	6	2
	48 V	5	2	—
	110 V	4	0.6	—
	220–240 V	4	—	—
	250 V	—	0.4	—
Display and Indications	Voltage Presence (LED and / or Relay) ³ : Green	—		
	Threshold Overrun: (fault): Red	—		
Setting Protection: Sealable Cover Enabling Local Reset and Test		—		
Mechanical Characteristics		Front-Panel Mount		DIN
Dimensions		2.8 x 2.8 x 3.0 in. (72 x 72 x 78 mm)		3.2 x 2.8 x 2.6 in. (81 x 63 x 65.5 mm)
Weight		0.7 lb. (0.32 kg)		0.5 lb. (0.23 kg)
Insulation Class (IEC 60664-1)		Front face		II
Degree of Protection	Front face		IP40	
	Other faces		IP30	
	Connections		IP20	
Sinusoidal Vibrations (Lloyd's and Veritas)		2 to 13.2 Hz ± 1 mm and 13.2 to 100 Hz–0.7 g		
Fire (IEC 60695-2-1)		—		
Environment		RH10	RH21	RH99
Damp Heat, Equipment not in Service (IEC 60068-2-30)		28 cycles +77°F (+25° C) / 170° F (+55° C) / RH 95%		
Damp Heat, Equipment in Service (IEC 60068-2-56)		48 hours, Environment Category C2		
Salt Mist (IEC 60068-2-52)		KB Test, Severity 2		
Degree of Pollution (IEC 60664-1)		3		
Electromagnetic Compatibility ⁴	Electrostatic Discharges (IEC 61000-4-2)	Level 4		
	Radiated Susceptibility (IEC 61000-4-3)	Level 3		
	Low-energy Conducted Susceptibility (IEC 61000-4-4)	Level 4		
	High-energy Conducted Susceptibility (IEC 61000-4-5)	Level 4		
	Radio / Frequency Interference (IEC 61000-4-6)	Level 3		
	Conducted and Radiated Emissions (CISPR11)	Class B		
Sensors and Accessories				
Sensors ⁵	A, OA Type Toroids	—		
	Merlin Gerin Rectangular Sensors for I Δ n ≥ 500 mA	—		
Cables	Relay / Sensor Link via Standard twisted Pair (not supplied)	—		

³ Depending on the type of wiring (optimum continuity of service or optimum safety)

⁴ Compatibility for both relay and sensor

⁵ Compatibility with E-type toroids in existing installations (see restrictions in Section 7, Installation and Dimensions)

Vigirex System Catalog
Section 3—Relay Characteristics

Figure 10: Tripping Curves—RH10, RH21, and RH99

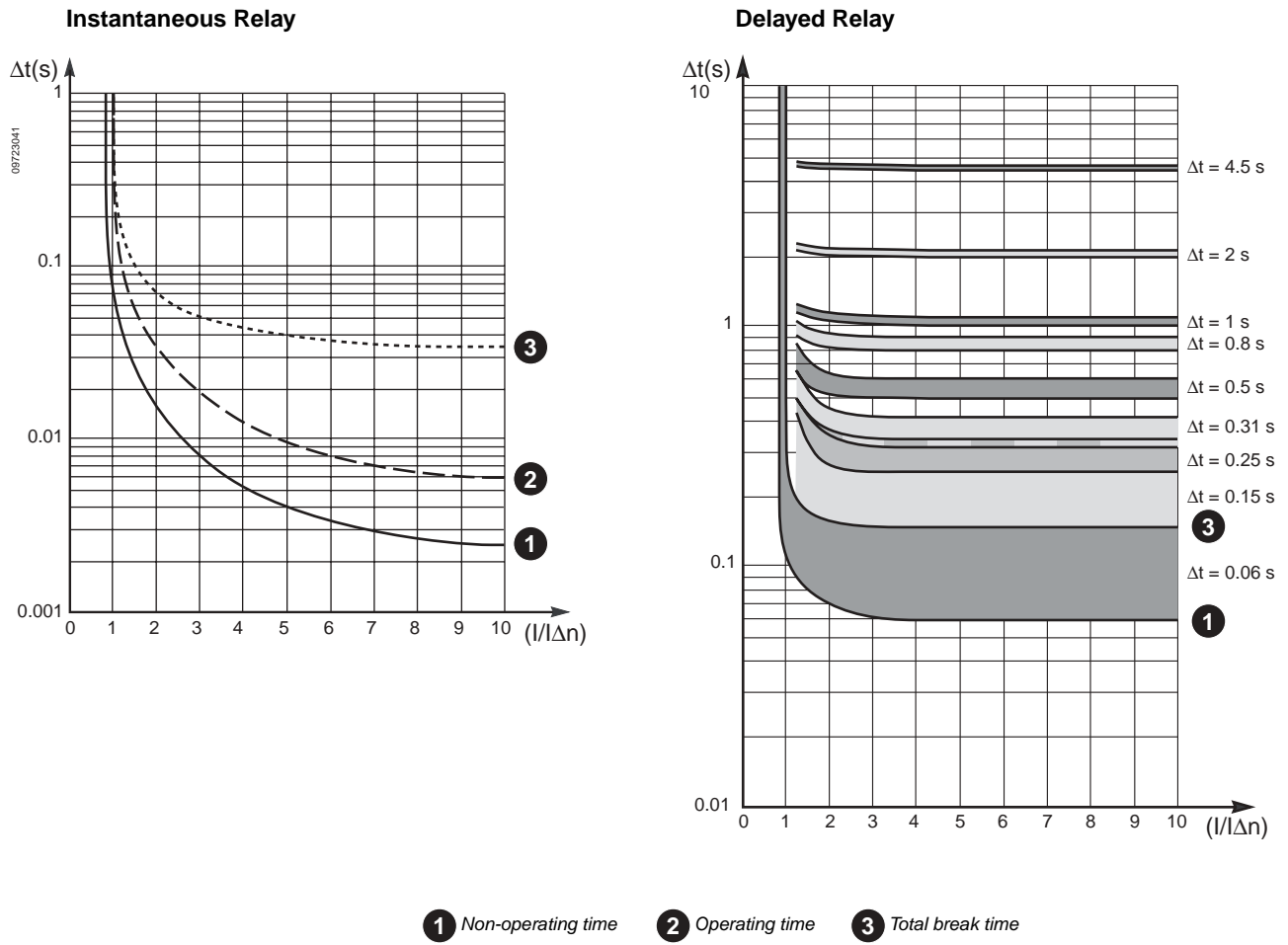

SECTION 4—SENSORS

INTRODUCTION

The sensors used for Vigirex relays enable the electronic relay to measure the zero-sequence currents flowing in the monitored circuit. They are designed to measure ground-fault currents and present a proportional signal to the relay. They also protect the relay from overvoltage and short-circuit currents in the line being monitored.

The Vigirex relay system includes a variety of sensors, which can be called current transformers (CTs) or zero-sequence transformers. They are available in three different configurations, and each configuration comes in different sizes.

- Closed toroids are suitable for new installations up to 630 A. (Certain toroids may be mounted on DIN rails, plates, or brackets; clipped onto the Vigirex relay; or tied to cables.)
- Split toroids facilitate installation in existing systems up to 400 A and may be installed on plates and brackets.
- Rectangular sensors are for busbars in installations with currents up to 3200 A.
- Suitable for line voltages up to 600 volts.

Figure 11: A Type Closed Toroid SA200



Figure 12: POA Split Toroid



Figure 13: Rectangular Sensor



Figure 14: Plug-on TA30 Type Toroid



Vigirex System Catalog

Section 4—Sensors

Measurement Dynamics

The measurement dynamics of ground-fault protection require a special magnetic circuit to measure very low currents and correct adaptation of the impedance (to avoid saturation) when measuring higher currents.

To that end, a compromise is required between each of these:

- a material with high magnetic permeability and its saturation phenomena;
- sensor size (cross-sectional area) and acceptable dimensions;
- a high number (n) of turns; but yet:
 - sufficiently low resistance
 - sufficient signal amplitude (gain 1/n).

Measurement Limits

When a three-phase current flows through the measurement sensor and there is no insulation fault (the sum of the currents is equal to zero), a secondary current equivalent to a false zero-sequence fault current is created. This is due to leakage flows caused by manufacturing tolerances. It is necessary to qualify this phenomenon by indicating the rated operational current for a given zero-sequence leakage current. See Table 9 on page 28.

NOTE: Strict compliance with the installation rules for the cables passing through the sensor is mandatory. The addition of a “magnetic sleeve” for the magnetic field considerably increases the rated operational current.

Rated Operational Current of the Sensors

Certain precautions may be required for sensor installation. This is because high currents (but not an insulation fault) can locally saturate the magnetic circuit of the sensor, creating abnormal flows that are interpreted on the secondary winding as zero-sequence currents.

The rated operational current for the sensors used with Vigirex devices:

- is indicated for the minimum setting value at 30 mA
- takes into account switching-in currents (up to $6 I_{\Delta n}$).

SELECTION OF TOROID AND RECTANGULAR SENSORS, DEPENDING ON THE POWER CIRCUIT

Example 1: A motor feeder (280 A at 400 V) must be monitored by a Vigirex relay with a toroid having a minimum diameter of 200 mm (SA200). This means that the device may be set to 30 mA instantaneous without risk of nuisance tripping. The rated operational current must be taken into account to avoid nuisance tripping; however, higher currents will not damage the toroid.

Example 2: On the motor feeder in example 1, the switching-in current is in fact significantly higher than $6 I_{\Delta n}$. To avoid possible tripping, it may be necessary to:

- use the same sensor but with a magnetic sleeve to channel the flux;
- use a sensor having a higher current rating and larger diameter; or
- increasing the time delay, yet coordination requirements for upstream RCDs.

These three measures may be implemented simultaneously.

SPECIAL PRECAUTIONS IN SEVERE ELECTRICAL NOISE ENVIRONMENT

Measurements in disturbed environments may require special wiring precautions:

- greater distance between the toroid wires and power circuits;
- use of shielded, twisted cables with the shielding grounded at one end;
- reduction to the shortest length possible for the cable between the toroid and the relay;
- use of a dedicated supply with galvanic isolation to eliminate conducted disturbances.

For severe operating conditions, the use of a mild steel magnetic sleeve placed around the cable inside the sensor considerably increases immunity.

NOTE: Always consult applicable codes before installing magnetic sleeve. When applying, do not compromise insulator system.

Recommended characteristics:

- mild steel foil 0.1 mm thick to be wrapped several times around the cable inside the toroid (minimum thickness 1 mm);
- inner diameter of the sensor > 1.4 x outer diameter of the cable bundle;
- length of sleeve $L \geq$ sensor diameter.

The current can be increased by adding a magnetic sleeve to channel the leakage flux.

Magnetic Sleeve (soft steel \geq 1 mm)		
L \geq sensor diameter		
L = 80 mm	L = 200 mm	L = 300 mm
TA30	MA120	GA300
PA50	SA200	—
IA80	—	—

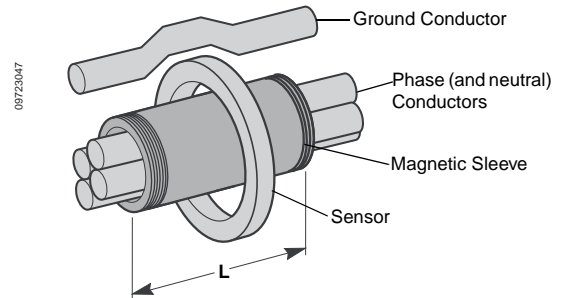

CONNECTION BETWEEN VIGIREX RELAYS AND SENSORS

Vigirex relays must be connected to the sensors as indicated:

Table 8: Wiring Characteristics

Cross-Section (Cu)—mm ² (in ²)	AWG	Maximum Length—m (ft)
Toroids		
0.22 (1)	20	18 (60)
0.75 (1)	18	60 (200)
1 (1)	16	80 (260)
1.5 (1)	14	100 (330)
Rectangular Sensors		
0.5 (0.0007) min. / 2.5 (0.0038) max.	20 / 12	10 (33)

(1) Wire size for resistance R maximum = 3 Ω

Cable Type

Standard twisted, shielded pair (not to be run alongside [parallel to] power cables)

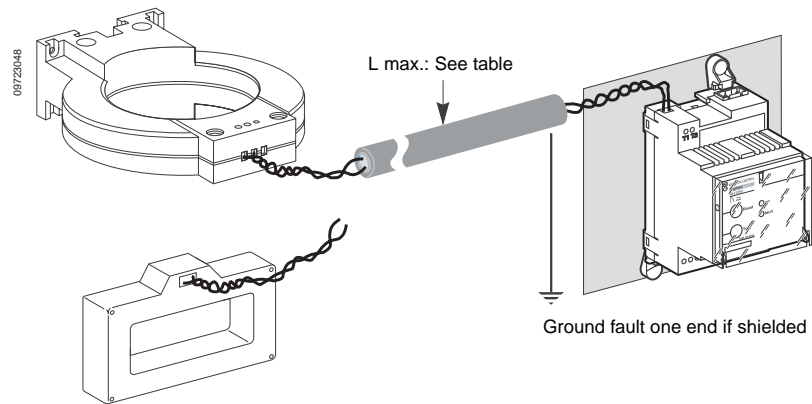

Vigirex System Catalog

Section 4—Sensors

Table 9: Sensor Specifications

Sensors		A Type Closed Sensor		OA Type Split Sensor		Rectangular Sensor	
Relays							
Relay Names		RH10, RH21, RH99				RH10, RH99 ⁽¹⁾	
General Characteristics							
Monitored Distribution System		50/60/400 Hz					
Voltage Rating		600 V					
Operating-temperature range		-31° F–158° F (-35°C–70°C)				-31° F–176° F (-35°C–80°C)	
Storage-temperature range		-67° F–185° F (-55°C–85°C)				-67° F–212° F (-55°C–100°C)	
Degree of Protection		IP30 (connections IP20)		—		IP30 (connections IP20)	
Electrical Characteristics							
Transformation Ratio		1/1000					
Rated short-time withstand current		100 kA/0.5 s					
Residual short-circuit withstand current (IEC 60947-2) (kA rms)		85 kA/0.5 s					
Rated Impulse Withstand Voltage Uimp		12 kV					
Sensor Characteristics							
Type of Sensor	Rated Operational Current (A)	Conductor Max. Size per phase mm ² Cu	AWG / kcmil	Dia. mm (in.)	Weight kg (lb.)	Inside dim. mm (in.)	Weight kg (lb.)
TA30	65	25	4	30 (1.18)	0.120 (0.26)	—	—
PA50	85	50	1/0	50 (1.97)	0.200 (0.44)	—	—
IA80	110	95	4/0	80 (3.15)	0.420 (0.925)	—	—
MA120	250	240	500	120 (4.72)	0.590 (1.3)	—	—
SA200	400	2 x 185	2 x 400	200 (7.97)	1.320 (2.9)	—	—
GA300	630	2 x 240	2 x 500	300 (11.81)	2.230 (4.9)	—	—
POA	85	50	1/0	46 (1.81)	—	—	—
GOA	250	240	500	110 (4.33)	—	—	—
Rectangular Sensor	1600	2 x 100 x 5	2 x 4/0 x 5	—	—	280 x 115 (11 x 4.5)	13.26 (29.2)
Rectangular Sensor	4000	2 x 125 x 5	2 x 250 x 5	—	—	470 x 160 (18/5 x 6.3)	21.16 (46.6)
Environment							
Damp Heat, equipment not in service (IEC 60068-2-30)		28 cycles 77° F (25° C) / 131° F (55° C) / RH 95%					
Damp heat, equipment in service (IEC 60069-2-56)		48 hours, Environment category C2					
Salt mist (IEC 60068-2-52)		KB test, severity 2					
Degree of pollution (IEC 60664-1)		3				4	

¹ For IΔn ≥ 500 mA with RH10, and RH99

SECTION 5—COORDINATION

The term “coordination” refers to the behavior of two or more series-connected devices in electrical power distribution in the event of an overcurrent or ground fault downstream.

When designing a ground-fault protection system, consideration must be given to two conflicting requirements: maximizing the continuity of service in as much of the system as possible, yet minimizing potential damage to equipment from thermal stress. A coordinated relay system allows this optimization.

The first requirement can be provided by coordination of the ground-fault protection scheme. Coordination involves using multiple levels of ground-fault relay protection and setting longer time delays and higher fault current pickups on upstream devices so as to allow downstream devices to trip first. This localizes the interruption of service at the lowest level possible.

Some of the Vigirex relays allow field-tuning of the pickup and delay settings to allow greater flexibility in coordination with both upstream and downstream devices. See Figure 15.

The second requirement is minimizing damage to equipment. The relay at the lowest level detecting a fault will operate with the least delay or without intentional delay (instantaneous). This clears the fault at the lowest level possible (minimizing the scope of the outage) and in the shortest time possible (minimizing the stress on the power system).

In equipment manufactured by an OEM, consideration should be given to the possibility that ground-fault protection could be included in the permanent facility wiring. In that case, the sensitivity and time delay of the equipment should be lower than that of the facility.

Figure 15: Coordination of Multiple Levels of Ground-Fault Protection

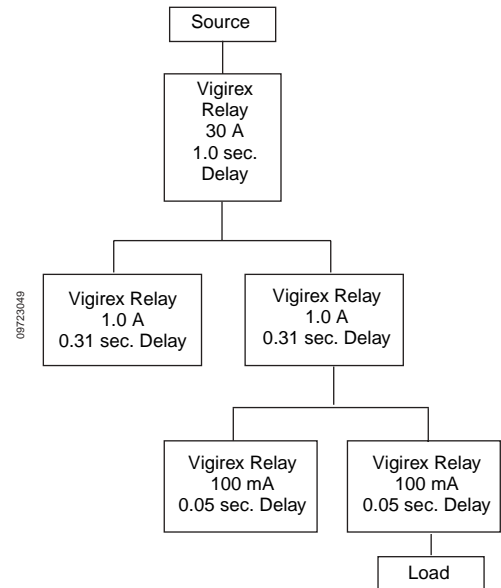

Vigirex System Catalog

Section 5—Coordination

IMPLEMENTING COORDINATION

Coordination between upstream and downstream ground-fault devices is ensured by considering:

- the operating-current settings, and
- the non-operating (time delay) and overall breaking times.

The following general coordination guidelines ensure correct operation:

- In terms of the current, the setting for the upstream device must be at least double that of the downstream device:
 - Upstream $I_{\Delta n} \geq 2 \times$ downstream $I_{\Delta n}$
- In terms of time, the non-operating time (time delay) for the upstream device must be greater than the total time (the intentional ground-fault device delay and the breaking time of the breaking device) for the downstream device.
 - upstream time delay $T \geq$ downstream total time T

The time / current curves indicate the operating-current values of the Vigirex devices depending on their standardized characteristics. When superimposed, the curves indicate the protection settings required to ensure total coordination (See Figure 10 on page 22, “Tripping Curves”).

The Vigirex devices, combined with Square D and Merlin Gerin breaking devices (switches, circuit breakers), have successive operating-current and time-delay settings that enhance the coordination rules mentioned above.

SECTION 6—APPLICATION OF VIGIREX GROUND-FAULT RELAYS

INTRODUCTION TO EQUIPMENT GROUND-FAULT PROTECTION

Ground-fault protection is a subject that is often overlooked when designing a protection scheme for an electrical system. Often, the only question asked is “Does the NEC require it?” Unfortunately, the NEC has minimal requirements and only specifies: “Ground-fault protection of equipment shall be provided for solidly-grounded wye electrical services of more than 150 volts to ground, but not exceeding 600 volts phase-to-phase for each service disconnect rated 1,000 amperes or more” (NEC 230-95, 215-10, 240-13).

The correct question to ask when specifying a circuit breaker for overcurrent protection is: “Why wouldn't I also need ground-fault protection to protect equipment against the most common of all faults?”

The following points should be considered when evaluating the need for ground-fault protection:

Installation in Equipment by the End-User

Ground-fault protection is needed for the following reasons:

- To protect costly equipment,
- To minimize costly downtime and expense for maintenance, and
- To minimize loss of production.

Installation in Equipment by the OEM

Ground-fault protection is needed for the following reasons:

- To give competitive advantage to finished product, and
- To minimize warranty risk to OEM (repair and liability).

Distribution Applications in Addition to NEC Requirements at Main Service

Ground-fault protection is needed at more levels than the minimum required by NEC for the following reasons:

- To avoid shutting down an entire facility when only one machine or circuit has a ground-fault—A properly coordinated system will provide protection at multiple levels by setting longer time delays and higher fault current pickups on upstream devices to allow the downstream devices to trip first. (See Section 5 on page 29.)
- To better protect equipment located far downstream of the main breaker with more sensitive ground-fault devices.
- To provide additional protection beyond over-current protection (nearly 85% of faults start as ground faults).

Alarming / Monitoring Applications

A need to set up the relay for an alarm only (but not protection) may be encountered in situations where an automatic shutdown would introduce additional hazards and therefore an operator must make the shutdown decision (e.g., continuous industrial processes, life-support equipment, or a fire pump circuit).

Critical processes of industrial machines can also benefit by application of Vigirex relays in alarm mode. In these cases, providing indication of higher than normal earth-leakage current can allow planned maintenance, rather than a costly disruption of production.

Vigirex System Catalog

Section 6—Application of Vigirex Ground-Fault Relays

Identifying the Right Applications

The Vigirex ground-fault relay may be used if the application requires one or more of the following:

- equipment protection (30 mA up to 30 A), including controls, motors, transformers, and cable;
- self-protection of the equipment or distribution system from damage due to arcing ground-faults;
- an earth-leakage alarm for emergency systems, per the NEC, or other critical processes;
- coordinated ground-fault protection to avoid nuisance tripping at a level upstream of the ground fault.

CONSEQUENCES OF AN INSULATION FAULT

An insulation fault occurs when a live conductor—phase or neutral—comes in contact with an exposed conductive part (e.g. motor casing).

The consequences depend upon the type of electrical system used in the installation or part of installation concerned. Such faults create hazards to life and property.

Ground-fault relays should be used in the following situations:

- a feeder with excessive cable length;
 - a circuit supplying portable equipment (such as socket outlet circuits); or
- a circuit where there is a risk of the protective conductor breaking.

Do not use the Vigirex ground-fault relay if:

- protection level of more than 30 A is required;
- circuit breaker already includes a ground-fault function, at an appropriate level;
- circuit breaker can have ground-fault option added economically;
- people protection (4–6 mA per UL 943) is required.

INTRODUCTION TO ELECTRICAL SYSTEMS

The Vigirex ground-fault relay is designed to be used in solidly-grounded electrical systems, the most common system in the United States, which is equivalent to the TN-S grounding system in Europe.

APPLICATIONS

TN-S Grounding System

This “multiple-grounded neutral” system has the following main features:

- the neutral point of the distribution transformer is grounded;
- all installation frames are grounded by a ground conductor; and
- the ground conductors and the N neutral conductor are separate.

This system’s characteristics and constraints upon installation:

- allows tripping on the first fault to ground;
- use of a ground-fault relay is recommended, although not compulsory;
- requires calculation, sometimes complex, of loop impedance; and
- tripping of the protection devices must be checked when these devices are installed.

Figure 16: TN-S Grounding System

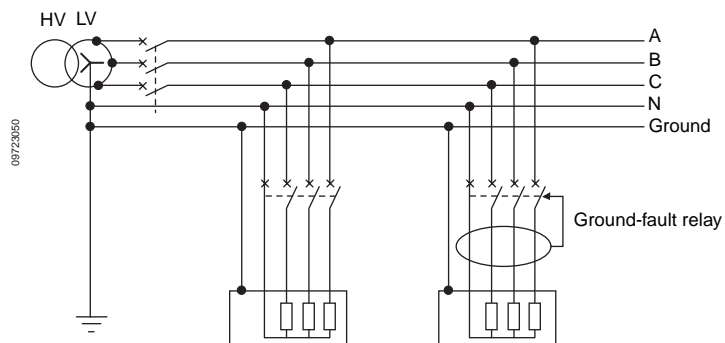

An insulation fault results in a short-circuit between phase and neutral. The resulting current flow is high. The exposed conductive parts are at a hazardous voltage. Tripping is essential.

Vigirex System Catalog

Section 6—Application of Vigirex Ground-Fault Relays

ELECTRICAL SHOCK HAZARD

NOTE: The Vigirex ground-fault relays are intended for protection of equipment and electrical distribution systems. They are NOT intended for protection of persons. The protection of persons requires the use of UL Listed 943 Class A ground-fault circuit interrupters (GFCIs).

Vigirex relays are NOT UL Listed to comply with UL standards for people protection.

WIRING DIAGRAMS—RH10, RH21, AND RH99

Wiring for Optimum Continuity of Service (with Shunt Trip)

All diagrams are shown with circuits de-energized, all devices open, and relays in released position.

Figure 17: RH10M, RH21M, and RH99M Wiring with MX Shunt Trip

- MX: Shunt Release
- Q1: Main Circuit Protection
- Q2: Circuit Breaker
- Q3: 1 A Circuit Breaker, curve C or D

RH10M, RH21M, and RH99M

- A1-A2: Auxiliary Power Supply Inputs
- T1-T2: A or OA Type Sensor or Rectangular Sensor (if $I_{\Delta n} \geq 500$ mA) Inputs
- 11-14: Operational (ON) Output
- 26-25: Device Test Input
- 27-25: Device Reset Input
- 31-32-34: Fault Relay Output

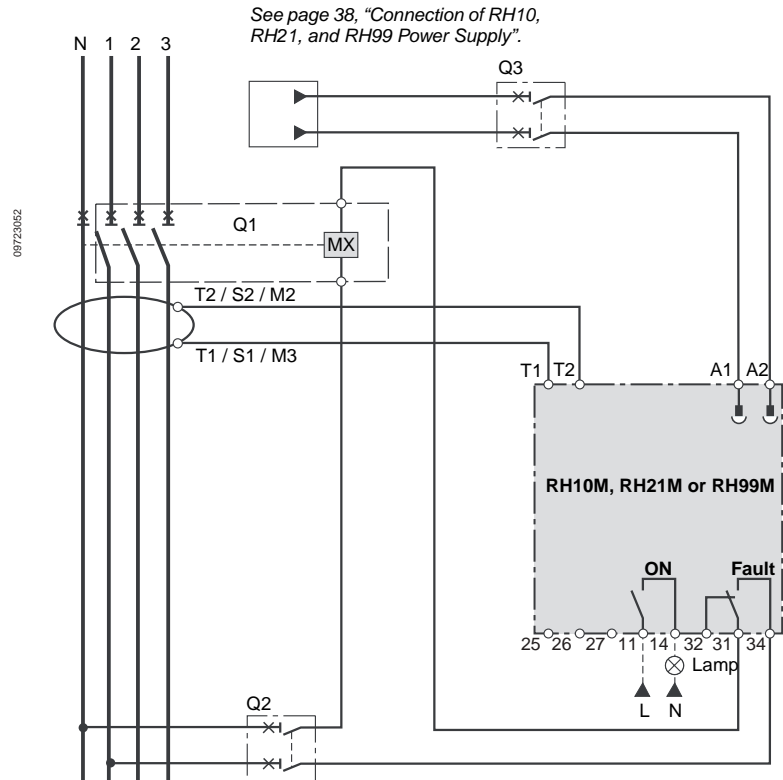

Vigirex System Catalog

Section 6—Application of Vigirex Ground-Fault Relays

Figure 18: RH10P, RH21P, and RH99P Wiring with MX Shunt Trip

MX: Shunt Release
 Q1: Main Circuit Protection
 Q2: Circuit Breaker
 Q3: 1 A Circuit Breaker, curve C or D

RH10P, RH21P, and RH99P

- A1-A2: Auxiliary Power Supply Inputs
- T1-T2: A or OA Type Sensor or Rectangular Sensor (if $I\Delta n \geq 500$ mA) Inputs
- 11-14: Operational (ON) Output
- 26-25: Device Test Input
- 27-25: Device Reset Input
- 31-32-34: Fault Relay Output

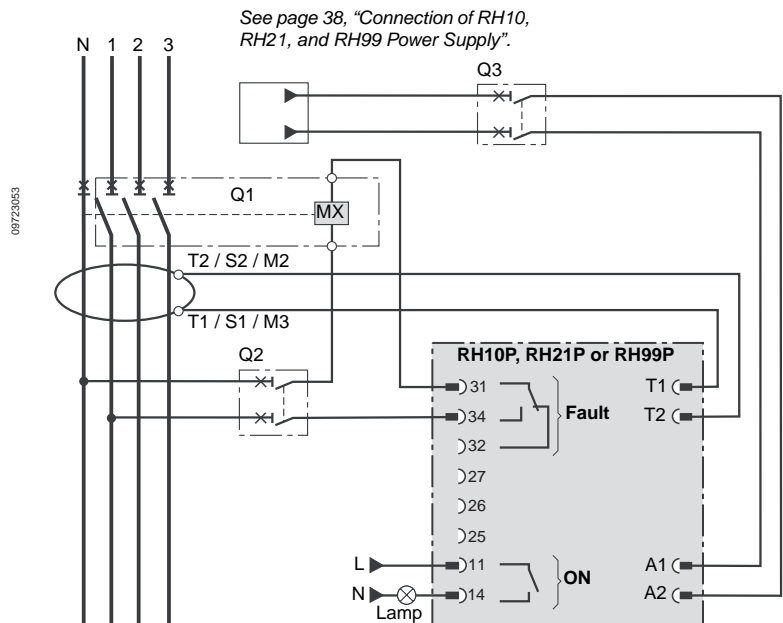

Wiring for Optimum Safety (with Undervoltage Release)

All diagrams are shown with circuits de-energized, all devices open, and relays in released position.

Figure 19: RH10M, RH21M, and RH99M Wiring with MN Undervoltage Release

MN: Undervoltage Release
 Q1: Main Circuit Protection
 Q2: Circuit Breaker
 Q3: 1 A Circuit Breaker, curve C or D

RH10M, RH21M, and RH99M

- A1-A2: Auxiliary Power Supply Inputs
- T1-T2: A or OA Type Sensor or Rectangular Sensor (if $I\Delta n \geq 500$ mA) Input
- 11-14: Operational (ON) Output
- 26-25: Device Test Input
- 27-25: Device Reset Input
- 31-32-34: Fault Relay Output

NOTE: For the RH99 with automatic reset, use the "fault" contact 31, 32, 34.

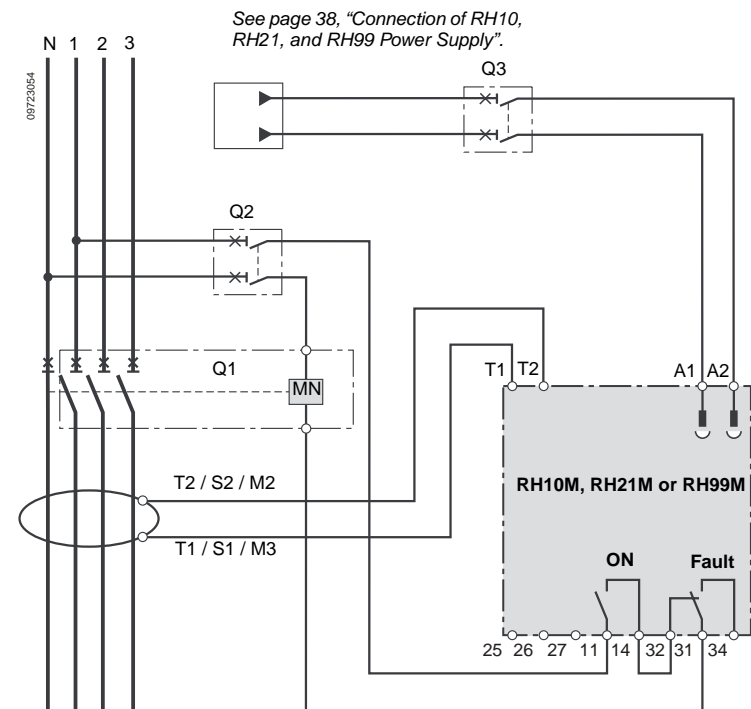

Vigirex System Catalog

Section 6—Application of Vigirex Ground-Fault Relays

Figure 20: RH10P, RH21P, and RH99P Wiring with MN Undervoltage Release

MN: Undervoltage Release
 Q1: Main Circuit Protection
 Q2: Circuit Breaker
 Q3: 1 A Circuit Breaker, curve C or D

RH10M, RH21M, and RH99M

- A1-A2: Auxiliary Power Supply Inputs
- T1-T2: A or OA Type Sensor or Rectangular Sensor (if $\Delta n \geq 500$ mA) Inputs
- 11-14: Operational (ON) Output
- 26-25: Device Test Input
- 27-25: Device Reset Input
- 31-32-34: Fault Relay Output

NOTE: For the RH99 with automatic reset, use the "fault" contact 31, 32, 34.

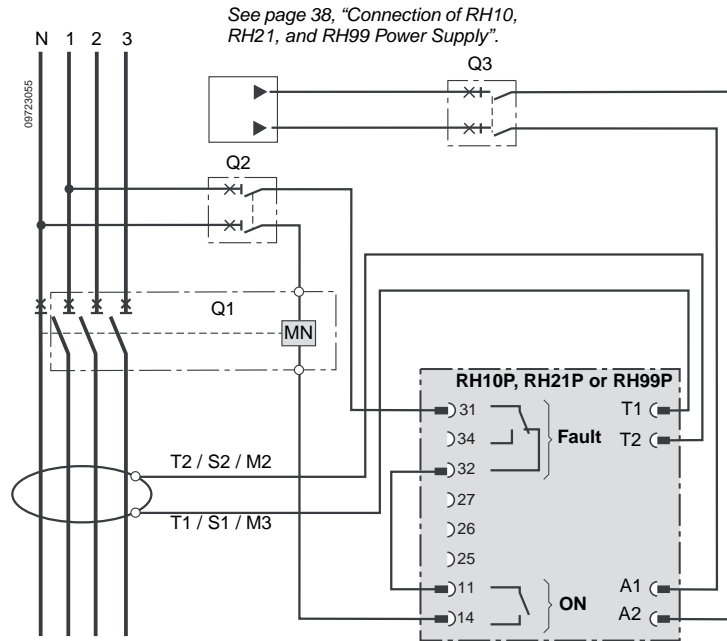
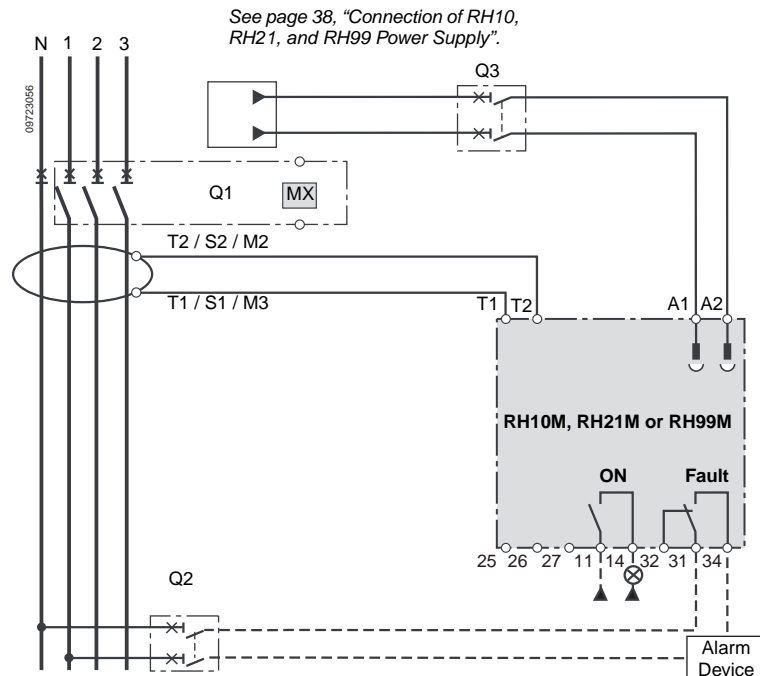

Figure 21: Cabling for Alarm

MN: Undervoltage Release
 Q1: Main Circuit Protection
 Q2: Circuit Breaker
 Q3: 1 A Circuit Breaker, curve C or D

RH10M, RH21M, and RH99M

- A1-A2: Auxiliary Power Supply Input
- T1-T2: A or OA Type Sensor or Rectangular Sensor (if $\Delta n \geq 500$ mA) Input
- 11-14: Operational (ON) Output
- 26-25: Device Test Input
- 27-25: Device Reset Input
- 31-32-34: Fault Relay Output



CONNECTION OF TEST AND REMOTE RESET FUNCTIONS

Cable

The cable must not exceed 33 ft. (10 m) in length. Use a cable with three twisted wires.

Contacts

Use pushbuttons with low-level contacts suitable for the minimum load of 1 mA at 4 V.

Figure 22: Wiring for Test and Reset

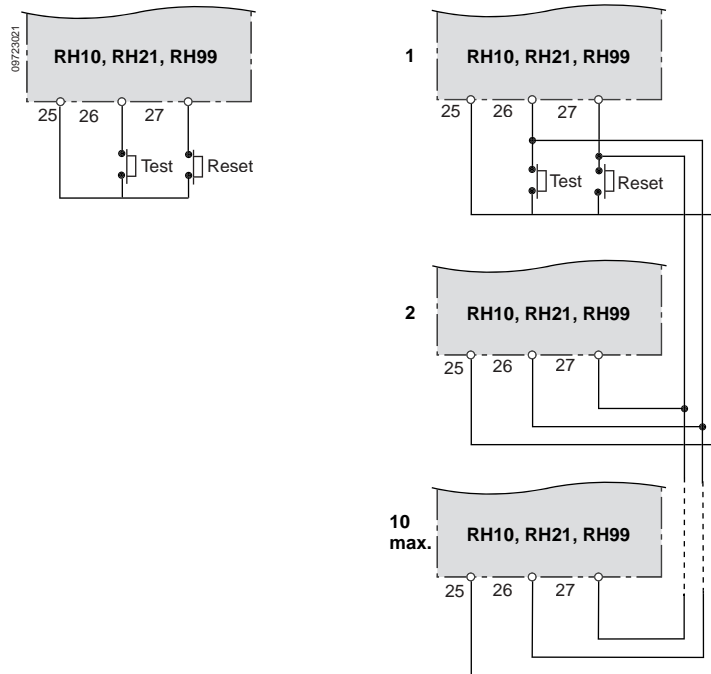

CONNECTION OF RH10, RH21, AND RH99 POWER SUPPLY

Figure 23: Alternative Power Sources

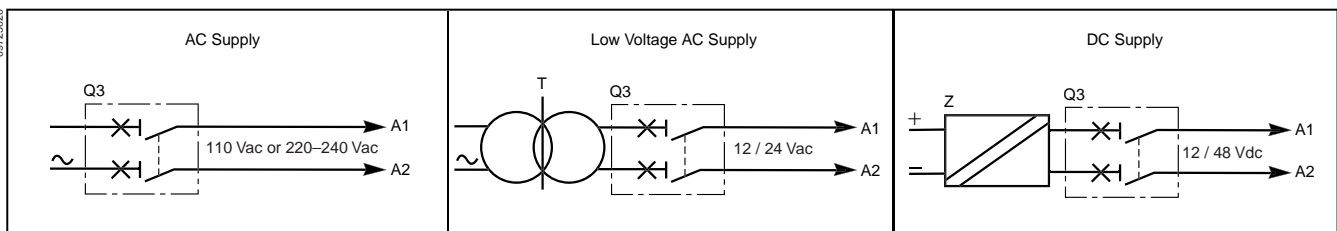

References T and Z: there is no galvanic isolation between A1, A2 and the control circuitry. User must provide, if needed.

Vigirex System Catalog
Section 6—Application of Vigirex Ground-Fault Relays

SECTION 7—VIGIREX RELAYS AND SENSORS INSTALLATION AND DIMENSIONS

POSSIBLE INSTALLATION POSITIONS

Figure 24: RH__M Format (RH10M, RH21M, and RH99M)

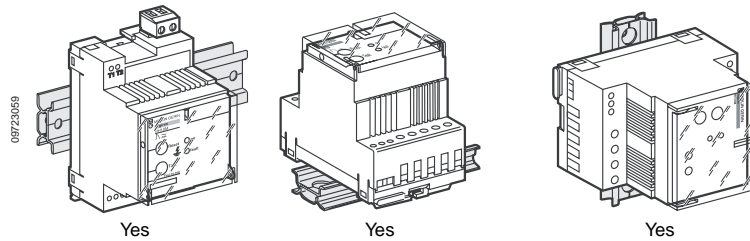
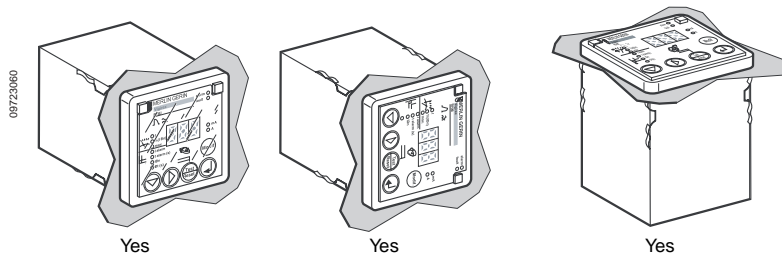

Figure 25: RH__P Mount Format (RH10P, RH21P, and RH99P)



RELAY MOUNTING POSSIBILITIES

Mounting of Relays RH10M, RH21M, RH99M

The RHM relays can be mounted in three ways:

- on a DIN rail;
- on a mounting plate using three removable mounting accessories (supplied) and three M4 screws (not supplied); or
- on a slotted mounting plate with M4 clip-on nuts.

Figure 26: Mounting Configurations

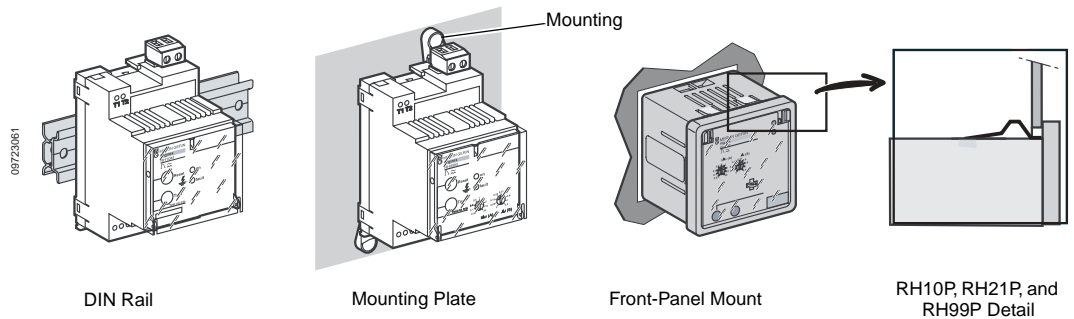

Vigirex System Catalog

Section 7—Vigirex Relays and Sensors Installation and Dimensions

DIMENSIONS—RH10M, RH21M, AND RH99M

Figure 27: Mounting on a DIN Rail

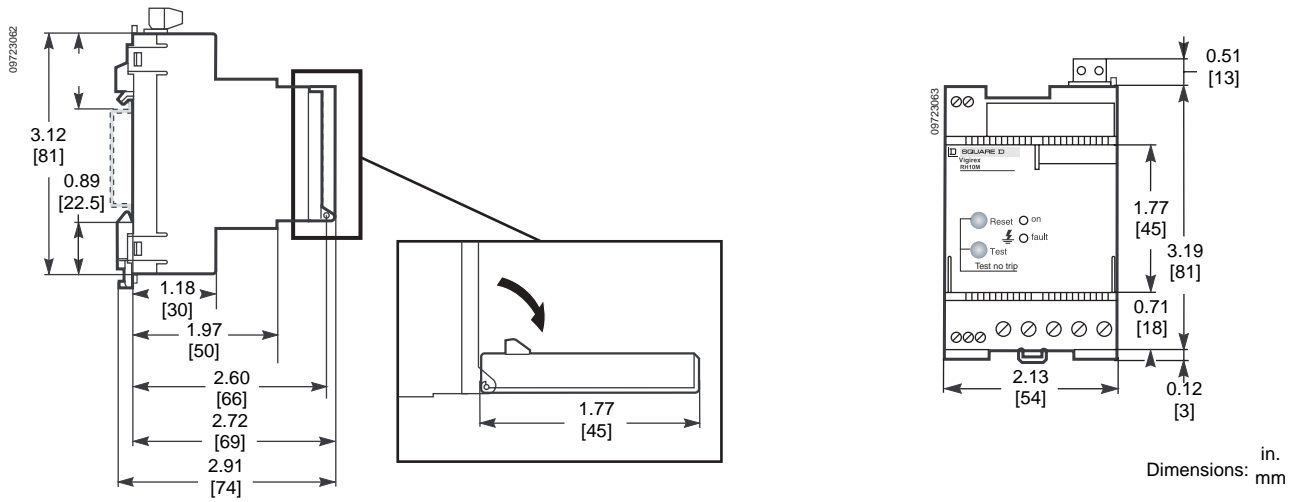

Figure 28: Mounting on a Mounting Plate

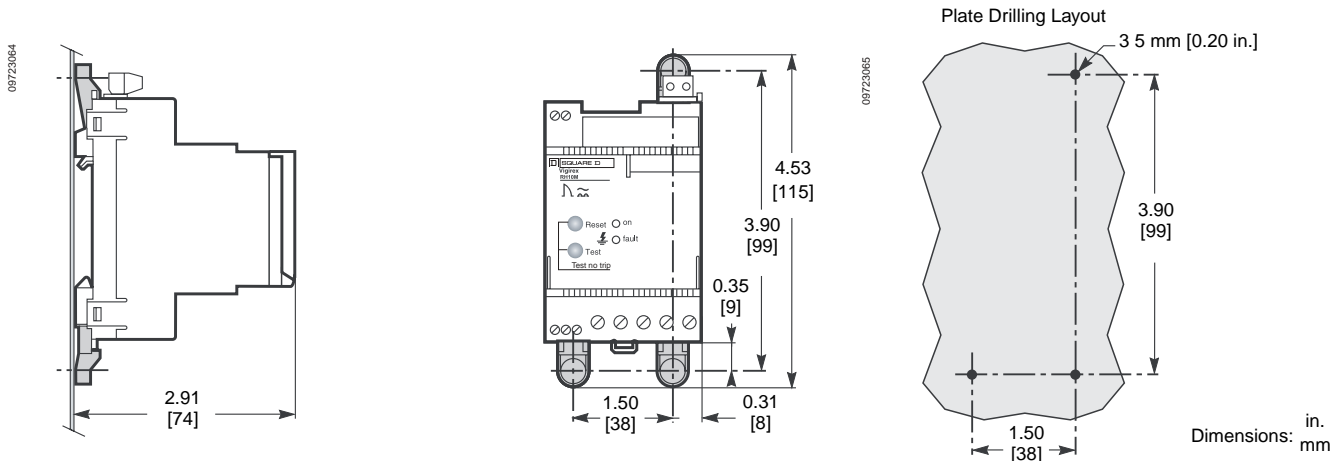
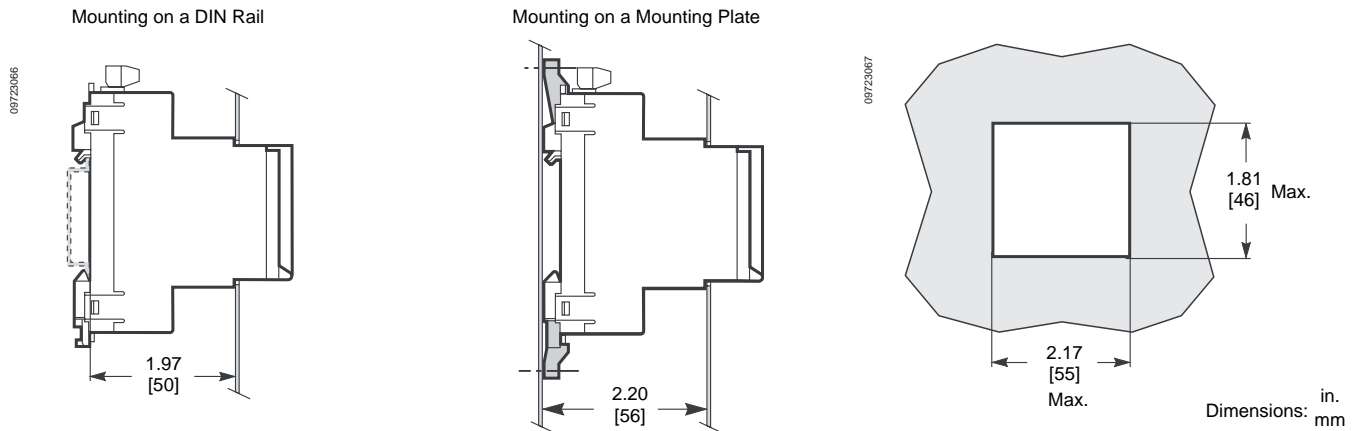

Figure 29: Door Cutout



Vigirex System Catalog

Section 7—Vigirex Relays and Sensors Installation and Dimensions

DIMENSIONS—RH10P, RH21P, AND RH99P

Figure 30: Front-Panel Mount Relays (Cutout Complying with Standard DIN 43700)

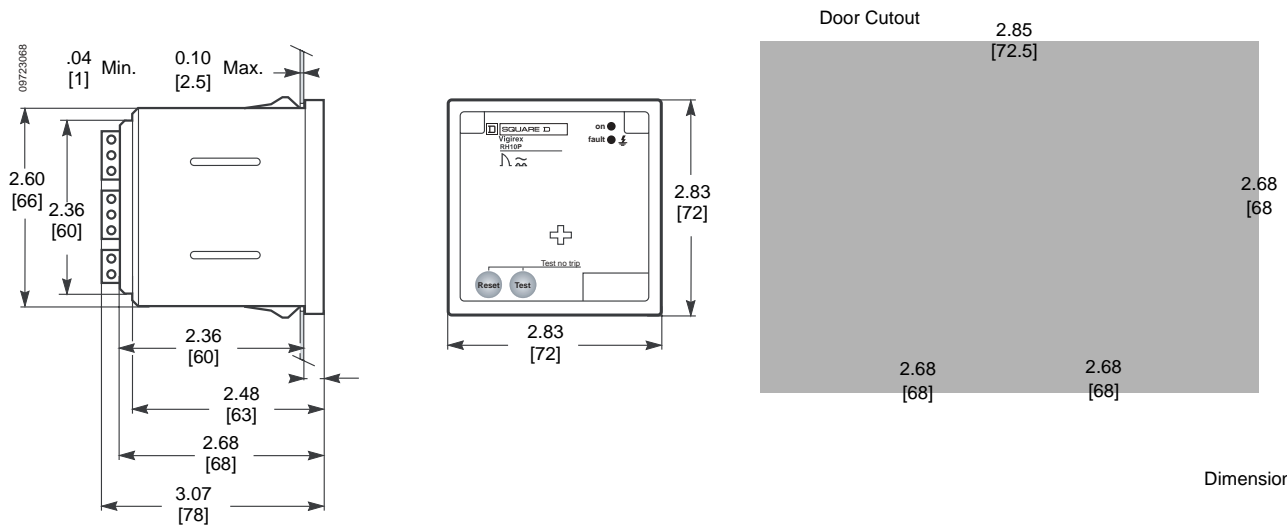

Vigirex System Catalog

Section 7—Vigirex Relays and Sensors Installation and Dimensions

CONNECTION (RELAYS AND SENSORS)

Figure 31: RH_ _M Connections

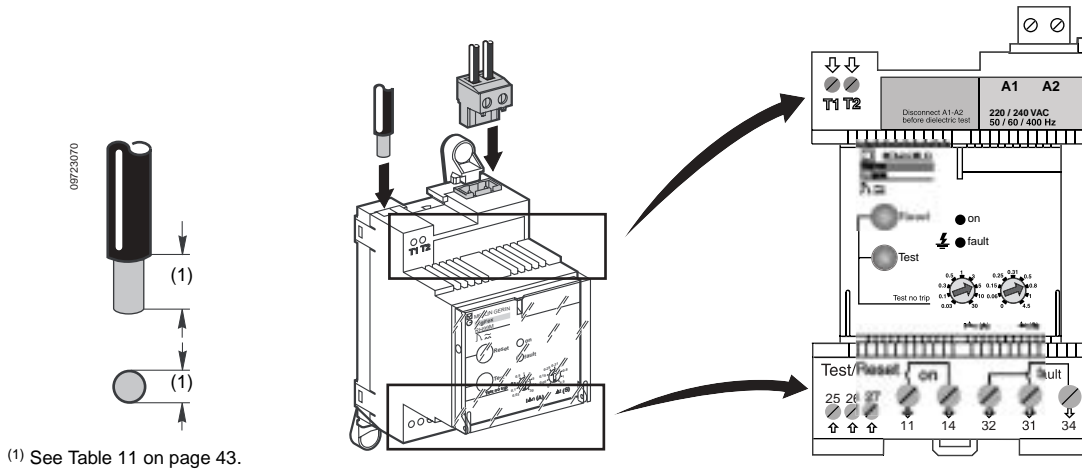
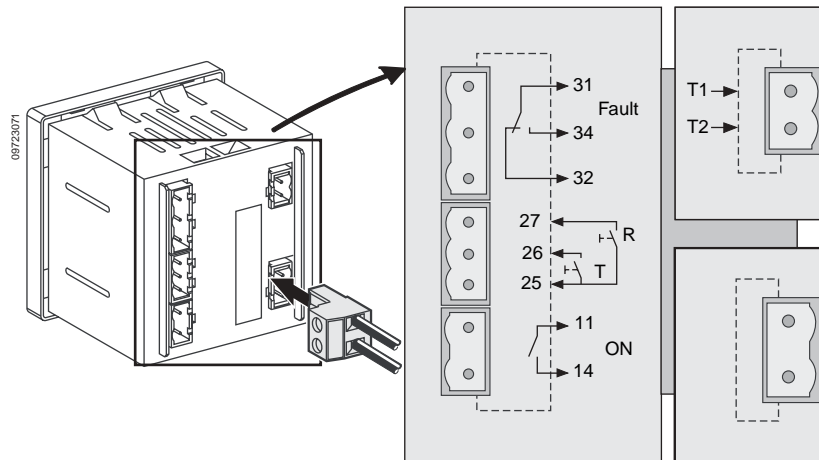

Figure 32: RH_ _P Mount Connections



Vigirex System Catalog

Section 7—Vigirex Relays and Sensors Installation and Dimensions

Table 11: Terminal Capacity

Product, Terminal, or Screw	Cable Type	Terminal Capacity (mm ²)						Conductor Size	Stripping		Tightening Torque	
		Solid		Stranded		Flexible w/ Ferrule		AWG	Solid / Stranded			
		min.	max.	min.	max.	min.	max.		(mm)	(in.)	(N•m)	(in-lbs)
RH10M, RH21M, and RH99M												
11, 14		0.2	4.0	0.2	2.5	0.25	2.5	24-12	8.0	0.31	0.6	0.0678
31, 32, 34		0.2	4.0	0.2	2.5	0.25	2.5	24-12	8.0	0.31	0.6	0.0678
A1, A2	Connector	0.2	2.5	0.2	2.5	0.25	2.5	24-12	7.0	0.27	0.6	0.0678
T1, T2	Twisted Pair	0.14	1.5	0.14	1.0	0.25	0.5	26-16	5.0	0.19	0.25	0.02825
25, 26, 27	3 twisted wires L<10 m	0.14	1.5	0.14	1.0	0.25	0.5	26-16	5.0	0.19	0.25	0.02825
RH10P, RH21P, and RH99P—All Wire Connectors												
11, 14		0.20	2.50	0.2	2.50	0.25	2.5	24-12	7.0	0.27	0.60	0.0678
31, 32, 34		0.20	2.50	0.2	2.50	0.25	2.5	24-12	7.0	0.27	0.60	0.0678
A1, A2		0.20	2.50	0.2	2.50	0.25	2.5	24-12	7.0	0.27	0.60	0.0678
T1, T2	Twisted Pair	0.20	2.50	0.2	2.50	0.25	2.5	24-12	7.0	0.27	0.60	0.0678
25, 26, 27	3 Twisted wires L<10 m	0.20	2.50	0.2	2.50	0.25	2.5	24-12	7.0	0.27	0.60	0.0678
Toroids and Rectangular Sensors												
30 mm to 200 mm diameter connectors supplied with TA30 and PA50	Twisted Cu / Al	0.2	2.5	0.2	1.5	0.2	1.5	24-16	6.0	0.23	0.5	0.565
GA300 2 Fasten connectors 6.35 x 0.8 mm (supplied with product)	Twisted Cu / Al	—	1.5	—	1.0	—	—	16	7.0	0.27	—	—
POA-GOA 5 mm diameter ring terminals not supplied:												
S1, S2	Twisted Cu / Al	—	—	—	—	—	—	—	—	—	3	0.339
Shunt		—	—	—	—	—	—	—	—	—	3	0.339
Tightening of 2 half-toroids		—	—	—	—	—	—	—	—	—	7	0.791
Mounting on a mounting plate		—	—	—	—	—	—	—	—	—	3	0.339
Rectangular Sensors M2, M3	twisted pair L<10 m	0.5	2.5	0.5	2.5	0.5	2.5	20-14	8 to 9	0.33	—	—

Vigirex System Catalog

Section 7—Vigirex Relays and Sensors Installation and Dimensions

SENSOR MOUNTING

Figure 33: TA30, PA50, IA80, or MA120 on DIN Rail Using Supplied Accessories

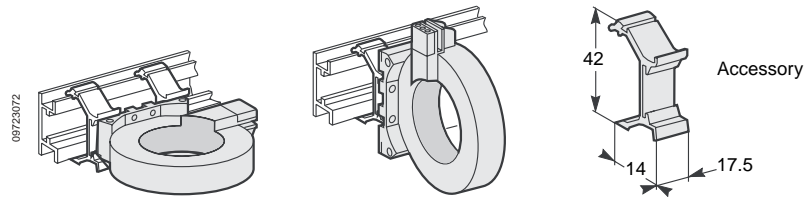

Figure 34: TA30, PA50, IA80, MA120, SA 200 GOA, or POA on a Plate or Bracket

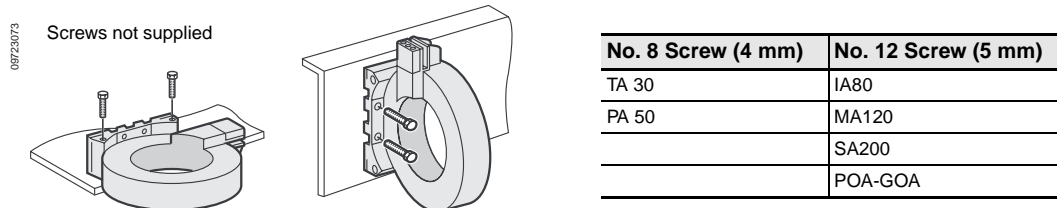

Figure 35: TA30 and PA50 Clipped on the Back of the Relay

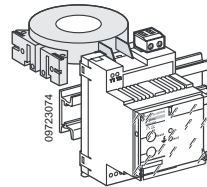

Figure 36: IA80, MA120, SA200, and GA300 Tied to Cables

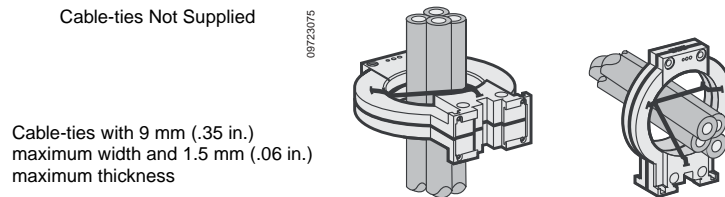

Figure 37: Rectangular Sensors Tied to Cables

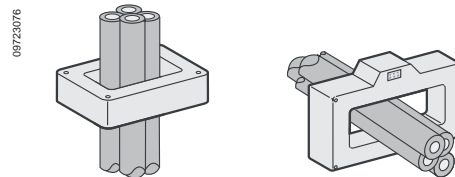
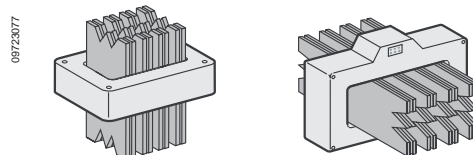

Figure 38: Rectangular Sensors on Bars with Chocks



CONDUCTOR INSTALLATION GUIDELINES

IMMUNITY TO LINE OVERCURRENT

Line overcurrents due to motor starting or transformer switching may cause unnecessary tripping of ground-fault relays.

This can be avoided by a few simple precautions with cumulative effects:

- place the toroid on a straight section of cable;
- center the cable in the toroid;
- use a toroid with a much larger diameter than the cable going through it; 2 x diameter.

CABLE LAYOUT

Figure 39: Cable with Toroid

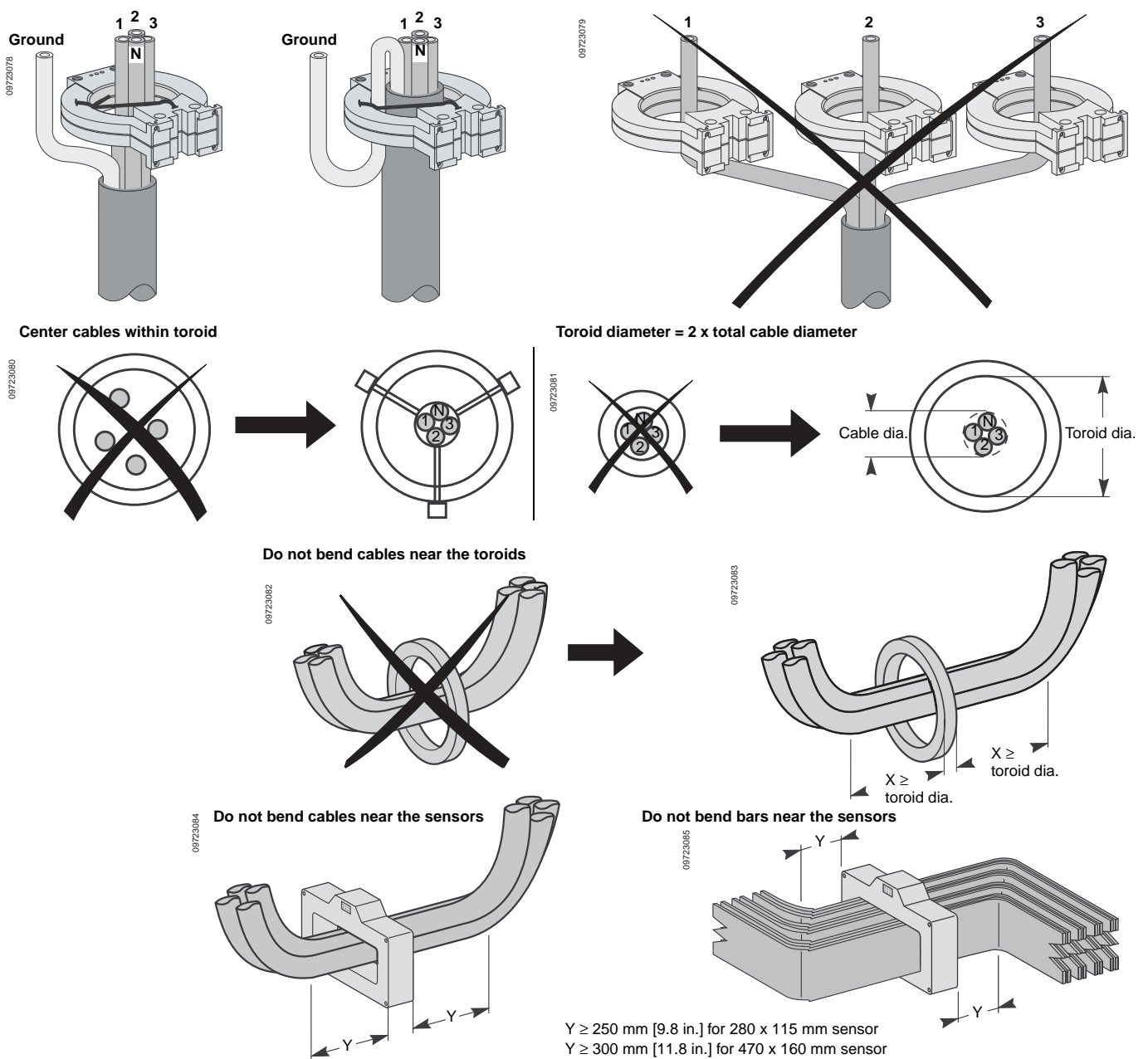

Vigirex System Catalog

Section 7—Vigirex Relays and Sensors Installation and Dimensions

CONNECTION OF TOROID SENSORS

Figure 40: Connecting Toroid Sensors

GA300 Closed Toroid
(2 Faston connectors 6.35 x 0.8 mm supplied)

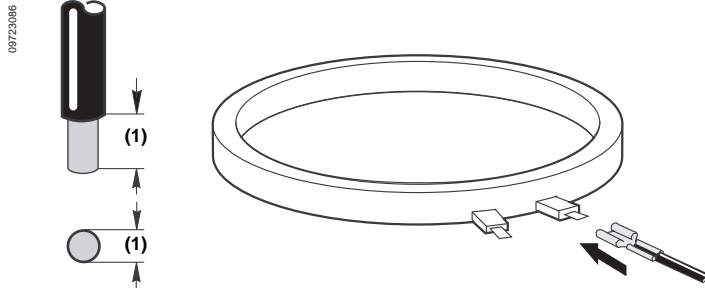

(1) See Table 12 on page 48.

POA and GOA Split Toroids
5 mm diameter round lugs not supplied

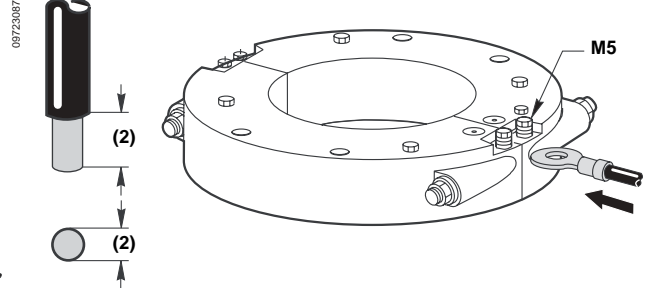

(2) Depending on the lug.

TA30 and PA50 Closed Toroids
(Connectors supplied)

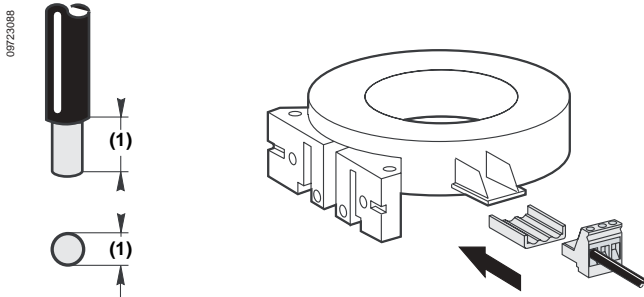

(1) See Table 12 on page 48.

IA80, MA120 and SA200 Closed Toroids

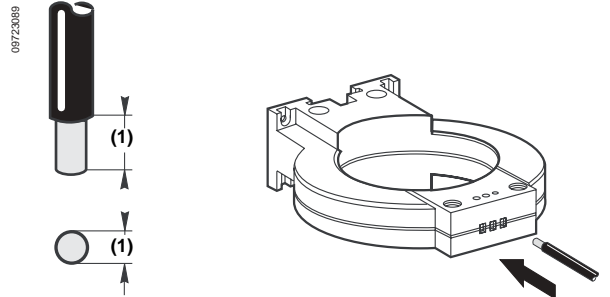

(1) See Table 12 on page 48.

Vigirex System Catalog

Section 7—Vigirex Relays and Sensors Installation and Dimensions

CONNECTION OF RECTANGULAR SENSORS AND CONDUCTOR LAYOUT

Figure 41: Connecting Rectangular Sensors

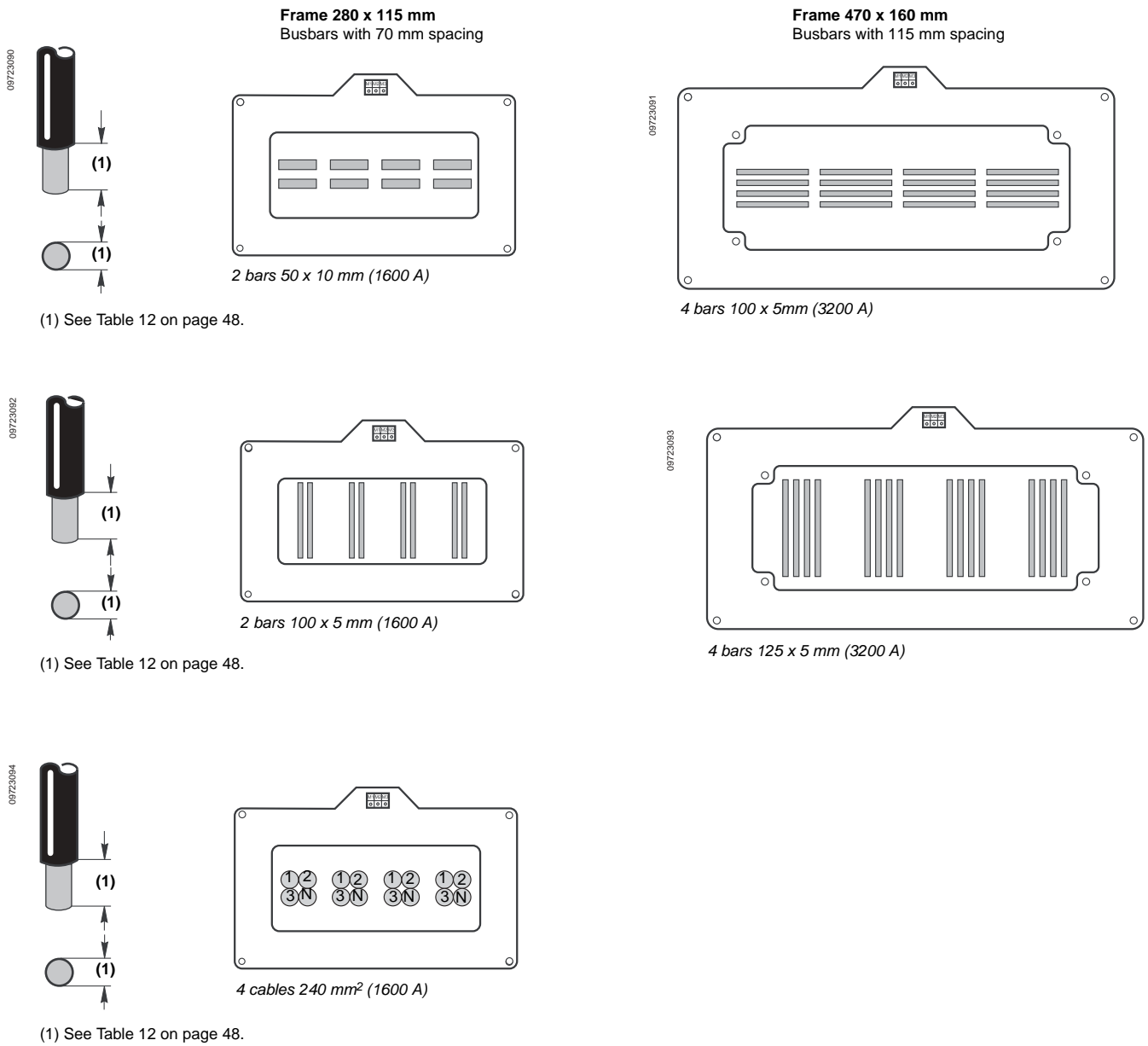

Vigirex System Catalog

Section 7—Vigirex Relays and Sensors Installation and Dimensions

CONNECTION BETWEEN VIGIREX RELAYS AND SENSORS

Vigirex relays must be connected to the sensors as indicated:

Table 12: Sensor Wiring

Wire Cross-Section (Cu)—mm ² (in ²)		Maximum Cable Length	
mm ²	AWG	Feet	m
0.22 (1)	20 (1)	60	18
0.75 (1)	18 (1)	200	60
1.0 (1)	16 (1)	260	80
1.5 (1)	14 (1)	330	100
Rectangular Sensors			
0.5 (0.0007) min. / 2.5 (0.0038) max.	20 –14	30	10

(1) Wire cross-section for a resistance of $R_{\text{maximum}} = 3$ ohms.

Cable Type

Standard twisted, shielded pair (not to be run alongside (parallel to) power cables)

Figure 42: Connecting Vigirex Relays and Sensors

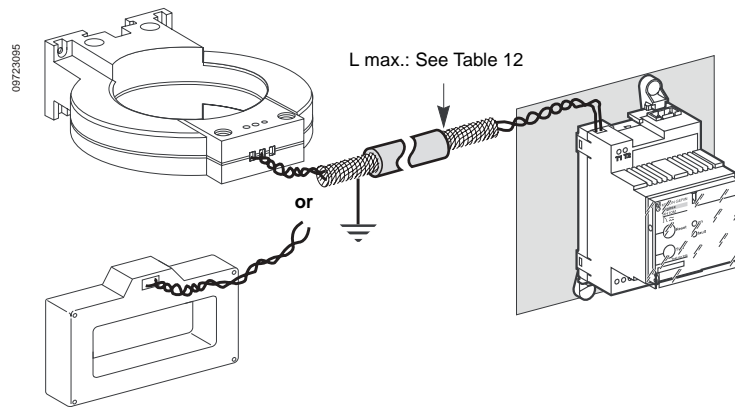

In Highly Disturbed Environments:

Measurements in disturbed environments may require special precautions:

- greater distance between the toroid wires and power circuits;
- use of twisted, shielded cables with the shielding grounded at one end;
- reduction to the shortest length possible for the cable between the toroid and the relay.

Figure 43: Connecting Vigirex Relays and Sensors in Highly Disturbed Environments

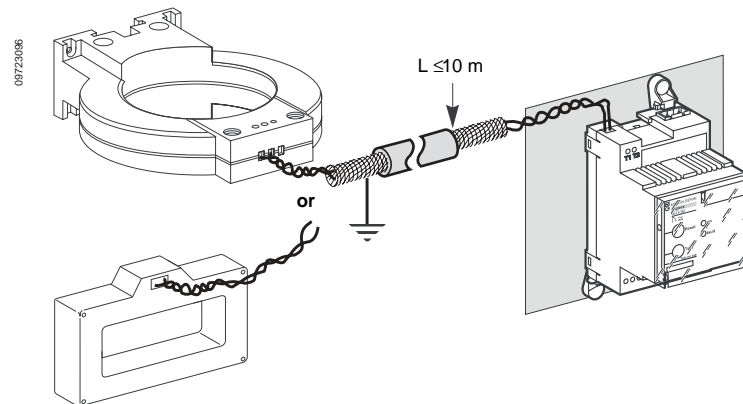

SECTION 8—DEFINITIONS

Coordination

Coordination of the automatic switching devices such that only the faulty part of the installation is cut off by opening of the device located immediately upstream of the fault.

Direct Contact

Human contact with the normally live parts of electrical equipment.

Double Insulation

Insulation that includes both:

- basic insulation required for protection against direct contact, and
- supplementary insulation required for protection against indirect contact in case of a fault of the basic insulation.

Earth Leakage

See “Ground-Leakage Current”.

EMC / EM

Electromagnetic compatibility (EMC): the ability of a device or system to operate in its electromagnetic (EM) environment satisfactorily and without itself producing unacceptable electromagnetic disturbances for its environment.

Earth (Ground)

The conducting mass of the earth, whose electric potential at any point is conventionally taken as zero.

Equipotential Bonding

Electrical connection putting various exposed conductive parts and extraneous conductive parts at a substantially equal potential.

Exposed Conductive Part

Any accessible metal part of an electrical equipment item other than the live parts and which can accidentally become live.

Fault (Electrical)

Accidental connection between two points at different potentials, such as an insulation fault. A fault may be solid or may exhibit a certain impedance. A solid fault between live conductors is a short circuit. A distinction is made between phase exposed conductive parts, phase-ground, phase-phase, phase-neutral, neutral exposed conductive parts and neutral-ground faults.

Fault Voltage

Voltage, in case of an insulation fault, across an exposed conductive part and an grounding reference; (i.e., a point on which the voltage is not modified when the exposed conductive part becomes live).

Ground Electrode

Conductive part that can be incorporated in a particular conductive environment, for example: concrete in electrical contact with earth.

Ground-Fault Current

Current flowing to ground due to an insulation fault.

Ground-Fault Protection (GFP)

The system used to measure zero-sequence currents that flow if a fault occurs in the TN-S system used in the United States (see TN-S).

Ground-Leakage Current

Current flowing from the live parts to ground or extraneous conductive parts in the absence of an insulation fault.

Vigirex System Catalog

Section 8—Definitions

Grounding Resistance

(Also “Overall Grounding Resistance”).

Resistance between the main grounding terminal (terminal or bar to which the grounding conductors are connected) and earth.

Indirect Contact

Contact of persons with exposed conductive parts accidentally live due to an insulation fault.

Insulation Voltage

(Preferred term: “Rated Insulation Voltage”).

The rated insulation voltage of an assembly is the voltage characterizing it and used as reference for the dielectric tests, the isolating distances and the creepage distance.

Intentional Leakage Current

Current flowing to ground or extraneous conductive parts via intentionally installed components (resistors or capacitors), in the absence of an insulation fault.

Isolated System

System with an autonomous supply of power; not connected to utility power.

IT

In an IT system, all the live parts are either isolated from earth or grounded at one point via an impedance. The exposed conductive parts of the electrical installation are grounded.

Leakage Current

See “Ground-Leakage Current” and “Natural Leakage Current”.

Live Conductor

Conductor used for transmission of electrical power during normal operation (including the neutral conductor).

National Electrical Code (NEC)

The National Electrical Code is the installation standard published in the United States.

Natural Leakage Current

Current flowing to ground or extraneous conductive parts via the insulation, in the absence of an insulation fault.

People Protection Devices

See “UL 943”.

Pickup Current (Residual Operating Current) ($I_{\Delta n}$)

The value of the residual current that causes a residual current device to operate.

Protective Ground Conductor (PE)

A conductor required for protection against electric shock for electrically connecting any of the following parts: exposed conductive parts, extraneous conductive parts, main grounding terminal, ground electrode, grounded point of the source or artificial neutral, metallic parts of the building structure that are not part of an electrical device, protected by equipotential bonding, if they are simultaneously accessible. The presence of switchgear on such conductors is prohibited.

RFI

Radio-Frequency Interference

RFI Filter

An RFI Filter limits radio-frequency disturbances.

RMS

Root Mean Square Value

Residual Current

Vector sum of the currents flowing through all the live conductors (phases plus neutral). It is equal to zero in the absence of an insulation fault. In case of an insulation fault, the residual current is the leakage current returned to the source through the ground and the protective conductor.

Residual Current Device (RCD)

A device that opens the associated switchgear when it detects a residual current above its residual operating current $I_{\Delta n}$ (see “Pickup Current”).

Residual Operating Current $I_{\Delta n}$

The value of the residual current that causes a residual current device to operate ($I_{\Delta n}$).

Sensor

The element of a ground-fault current sensing and relaying equipment that detects ground-fault current and transmits a resulting signal to ground-fault relaying equipment. In the Vigirex system, these are toroid, split-core, or rectangular current transformers (CTs).

Service Voltage

(Preferred term: “Rated Operating Voltage”).

The rated operating voltage (U_e) of a system is the voltage which, together with the rated current of the system, determines the load. For three-phase systems, it is the voltage between phases.

TN

In the TN system, a point in the supply system is connected directly to earth. The exposed conductive parts of the electrical installation are connected to this point via protective conductors.

TN-S

The TN-S system is a TN system in which a protective conductor separate from the neutral is used throughout the installation. This is common in the United States.

TT

In the TT system, a point in the supply system is connected directly to earth. The exposed conductive parts of the electrical installation are connected to earth electrodes that are electrically separate from that for the supply system.

Time Delay

Intentional delay before operation of a device. The time delay on operation of an upstream circuit breaker allows time discrimination with the downstream circuit breaker. The time delay, which is voluntary, should not be confused with the break time of a device, which is intrinsic to the device.

Touch Voltage

Voltage in case of an insulation fault across simultaneously accessible parts.

UL 943

UL 943 Class A defines the requirements for protection of personnel from ground-fault current. The Vigirex system does not fulfill these requirements.

UL 1053

UL 1053 is the standard for ground-fault sensing and relaying equipment under which the Vigirex Relay System is Listed. It is intended for protection of equipment and wiring, and not as people protective (see “People Protection Devices”).

Zero-Sequence Current

A method of electrically summing all currents in an electrical line. Any non-zero sum indicates the presence of leakage of current to ground.

Schneider Electric USA
3700 Sixth St SW
Cedar Rapids, IA 52404
1-888-SquareD
(1-888-778-2733)
www.SquareD.com

Schneider Canada Inc.
19 Waterman Avenue,
M4B 1 Y2
Toronto, Ontario
1-800-565-6699
www.schneider-electric.ca

Catalog No. 0972CT0401 April 2004 © 2004 Schneider Electric All Rights Reserved