

Wall-Mounted Network Equipment Rack Heavy Duty, 19" Panel Mount

- Rated for 350 lb. (159kg) load capacity (assuming suitable mounting surface)
- Double sided universal ($\frac{5}{8}$ " (16mm), $\frac{5}{8}$ " (16mm), $\frac{1}{2}$ " (13mm)) mounting spacing.
- #12-24 panel mounting holes.
- Conformance to EIA/ECA-310-E.
- 19" (482mm) width (other sizes are available upon request)
- 25" (635mm), 39" (990mm) and 74" (1879mm) heights
- 18" (457mm), 24" (609mm) and 30" (762mm) depths
- Permanently stamped rack mount unit (RMU) markings included.
- Packaged unassembled in protective carton suitable for parcel shipment.
- Installs in about fifteen (15) minutes using standard hand tools.
- Material: Aluminum uprights and steel extension brackets
- Finish ____: Brushed (AL)
Telco Gray Powder Coat (TG) or Flat Black Powder Coat (FB)
Other finishes are available upon request

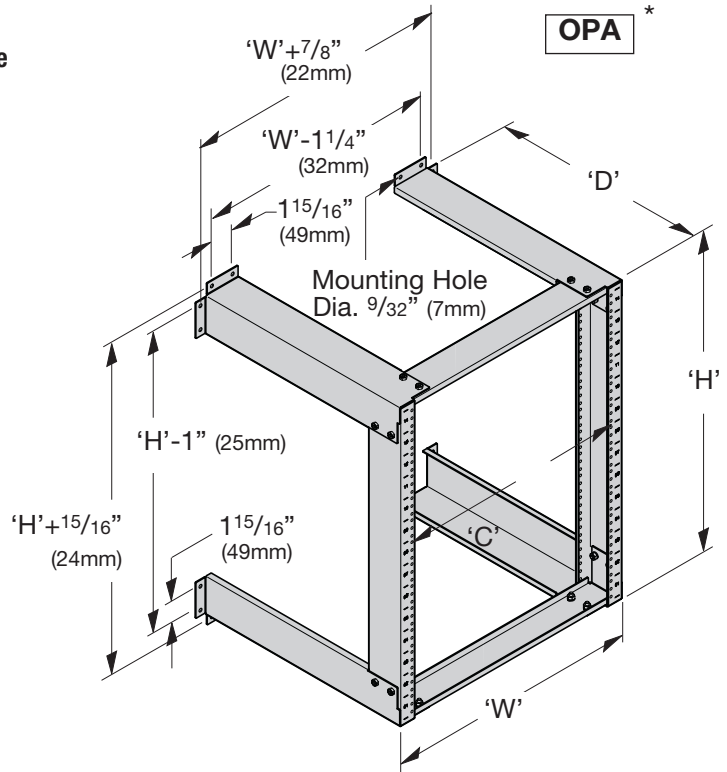

Mounting Spaces for Height 'H' of
25 $\frac{1}{4}$ " - 14 spaces • 39 $\frac{1}{4}$ " - 22 spaces • 74 $\frac{1}{4}$ " - 42 spaces

Part Number	'W' Rack Width		'H' Height		'C' Panel Mounting		'D' Depth		Weight	
	In.	(mm)	In.	(mm)	In.	(mm)	In.	(mm)	Lbs.	(kg)
SB704192518__	20 $\frac{1}{2}$ "	(521)	25 $\frac{1}{2}$ "	(648)	18 $\frac{5}{16}$ "	(465)	18"	(457)	16.6	(7.5)
SB704192524__	20 $\frac{1}{2}$ "	(521)	25 $\frac{1}{2}$ "	(648)	18 $\frac{5}{16}$ "	(465)	24"	(609)	19.8	(9.0)
SB704192530__	20 $\frac{1}{2}$ "	(521)	25 $\frac{1}{2}$ "	(648)	18 $\frac{5}{16}$ "	(465)	30"	(762)	22.9	(10.4)
SB704193918__	20 $\frac{1}{2}$ "	(521)	39 $\frac{1}{2}$ "	(1003)	18 $\frac{5}{16}$ "	(465)	18"	(457)	18.7	(8.5)
SB704193924__	20 $\frac{1}{2}$ "	(521)	39 $\frac{1}{2}$ "	(1003)	18 $\frac{5}{16}$ "	(465)	24"	(609)	21.8	(9.9)
SB704193930__	20 $\frac{1}{2}$ "	(521)	39 $\frac{1}{2}$ "	(1003)	18 $\frac{5}{16}$ "	(465)	30"	(762)	25.0	(11.3)
SB704197418__	20 $\frac{1}{2}$ "	(521)	74 $\frac{1}{2}$ "	(1892)	18 $\frac{5}{16}$ "	(465)	18"	(457)	24.0	(10.9)
SB704197424__	20 $\frac{1}{2}$ "	(521)	74 $\frac{1}{2}$ "	(1892)	18 $\frac{5}{16}$ "	(465)	24"	(609)	27.1	(12.3)
SB704197430__	20 $\frac{1}{2}$ "	(521)	74 $\frac{1}{2}$ "	(1892)	18 $\frac{5}{16}$ "	(465)	30"	(762)	30.2	(13.7)

*See page 8 for OPA details.