

# Superstrut® Support Systems

## 1-5/8" x 1-5/8 Channel

### Superstrut® 1-5/8" x 1-5/8" - 12 Gauge Channel Type A

Solid Base



Punched

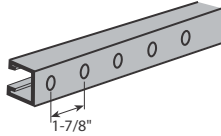

Half Slots

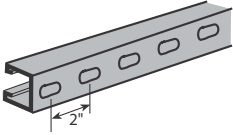

Long Slots

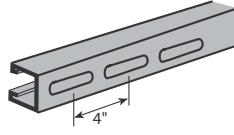

Knockouts

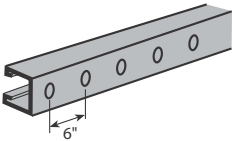

Back to Back



#### Catalogue Number Description

A1200	Solid base
A1200-P	Punched
A1200-HS	Half slots
A1200-S	Long slots
A1200-KO	Knockouts
A1202	Back to back

Example: A1200HS10ALC, A120020HDGC

#### Finishes & Materials

No Suffix	Gold galvanized dichromate finish
ALC	Aluminum
EG	Electrogalvanized
HDGC	Hot dipped galvanized
PGC	Pregalvanized
T316L	Stainless steel Type 316

- Offered in 10 or 20 ft lengths.
- Aluminum, hot dipped galvanized or stainless steel channels are recommended to support aluminum steel or stainless steel cable tray.

### Channel Nuts

#### A100

#### Regular Spring Nut

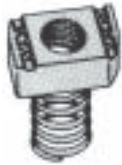

AC100  
Springless Nut



UC100  
Universal Nylon Cone Nut



For all 1-5/8" and 1-1/2" channels  
May be used with ALL Strut Depths.

#### Catalogue Number Size

A100-1/4EGC	1/4	Standard Finish:
A100-5/16EGC	5/16	
A100-3/8EGC	3/8	Electrogalvanized
A100-1/2EGC	1/2	Stainless steel channel nuts are recommended for aluminum channel and cable tray rungs.
A100-5/8EGC	5/8	
A100-3/4	3/4	
A100-7/8EGC	7/8	
Nut is square over 1/2" size.		Change suffix to SS6(C).
AC100-1/4EGC	1/4	Standard Finish:
AC100-3/8EGC	3/8	Electrogalvanized
AC100-1/2EGC	1/2	Stainless steel channel nuts are recommended for aluminum channel and cable tray rungs.
AC100-5/8	5/8	
AC100-3/4	3/4	
UC100-1/4	1/4	
UC100-3/8	3/8	
UC100-1/2	1/2	

### Hex. Head Cap Screw



#### Catalogue Number Size

E142-1/4x100EG	1/4 x 1	Standard finish
E142-1/4x150EG	1/4 x 1-1/2	
E142-3/8x100EG	3/8 x 1	Electrogalvanized
E142-3/8x150EG	3/8 x 1-1/2	Available in stainless steel
E142-1/2x100EG	1/2 x 1	Change suffix to SS6(C)
E142-1/2x150EG	1/2 x 1-1/2	

For our complete selection, consult our Superstrut® catalogue.

# Superstrut® Support Systems

## 1-5/8" x 1-5/8" Channel

### Superstrut® Fittings and Brackets

**AB241HDGC**

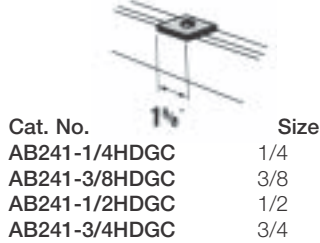

Cat. No.	Size
AB241-1/4HDGC	1/4
AB241-3/8HDGC	3/8
AB241-1/2HDGC	1/2
AB241-3/4HDGC	3/4

**AB206HDGC**

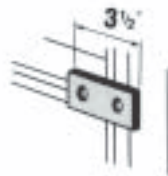

**AB207HDGC**

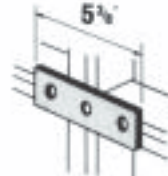

**X207HDGC**

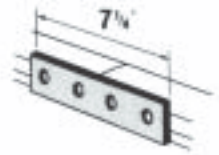

**AB201HDGC**

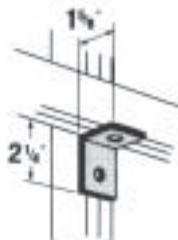

**AB202HDGC**

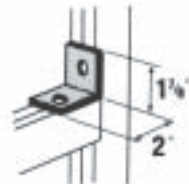

**AB203HDGC**



**AB204HDGC**

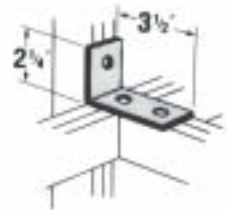

**AB205HDGC**

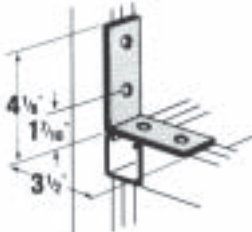

**AB213HDGC**

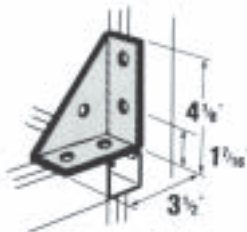

**AB214HDGC**

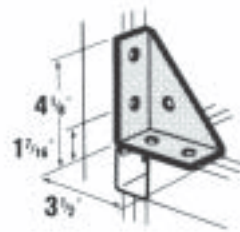

**AB254-LHDGC**

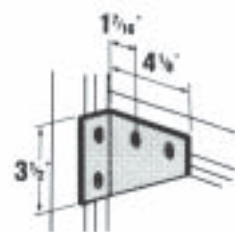

**AB254-RHDGC**

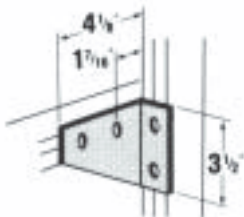

**X289HDGC**

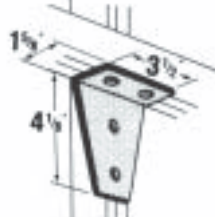

**AP232HDG**

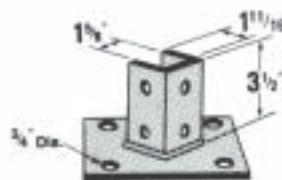

**AP235HDGC**



**S249HDG**



Cat. No.	A	B	Design Load/lb
S249-8HDG	8-1/2	8	1500
S249-14HDG	14-1/2	9	1500
S249-20HDG	20-1/2	9	1500
S249-26HDG	26-1/2	11-1/2	1500
S249-32HDG	32-1/2	11-1/2	1500
S249-38HDG	38-1/2	11-1/2	1500

**S256HDGC**



Cat. No.	A	Design Load/lb
S256-8HDGC	8-1/2	1000
S256-14HDGC	14-1/2	500
S256-20HDGC	20-1/2	300
S256-26HDGC	26-1/2	250

When installed in inverted position reduce load rating 40%. Strut section made from half slot channel.

**S251HDGC**

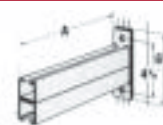

Cat. No.	A	Design Load/lb
S251-14HDGC	14-1/2	1650
S251-20HDGC	20-1/2	800
S251-26HDGC	26-1/2	650
S251-32HDGC	32-1/2	500
S251-38HDGC	38-1/2	500

Hot dipped galvanized HDG(C) or stainless steel SS6(C) fittings are recommended to assemble aluminum channel. Also available in Electrogalvanized (EG) and Gold galvanized dichromate (no suffix).

For our complete selection, consult our Superstrut® catalogue.

Standard Dimensions: Hole Spacing 13/16" from end  
Hole Size 9/16" dia.

Hole Spacing 1-7/8" centers  
Fitting width 1-5/8"

# Superstrut® Support Systems

## Quick-Clamp II (TBQC)

### Quick-Clamp II



**True one-piece construction** — arrives ready to install

**NO breaking apart** — half the installation time of break apart clamps

**Integral bolt and captive nut** — no separate pieces to lose

**One size fits EMT and rigid conduit** — takes the guesswork out of clamp selection. Pipe size and catalogue number stamped right on clamp.

**Attaches a complete range of EMT and rigid conduit (1/2 in. to 4 in.)** to strut channels

**Multi-driver combo bolt head** — accepts a wrench, most screwdrivers or 1/2 in. nut driver

**Field-adjustable angle ( $\pm 4^\circ$ )** — easy installation even when strut is not square

**Embossed J-hooks** increase loading capabilities

**T&B flex window** provides wrapping action around pipes

**Easy reconfiguration without complete disassembly** — easily accessible angled bolt allows for field adjustments and closer conduit spacing

**Electrogalvanized finish** — additional corrosion resistance



### Ordering information

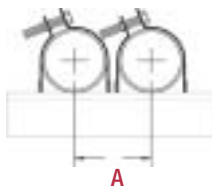

Catalogue Number	Dimension A for EMT inches (mm)	Dimension A for Rigid Conduit inches (mm)	Quantity per Box
TBQC050	1-5/16 (33.5)	1-1/4 (31.5)	100
TBQC075	1-3/4 (44.5)	1-11/16 (43)	100
TBQC100	1-13/16 (46)	1-3/4 (44.5)	100
TBQC125	2-1/8 (54)	2 (51)	50
TBQC150	2-3/8 (60.5)	2-3/16 (55.5)	50
TBQC200	2-5/8 (66.5)	2-1/2 (63.5)	50
TBQC250	3-1/16 (78)	3-1/16 (78)	25
TBQC300	3-11/16 (93.5)	3-11/16 (93.5)	25
TBQC350	4-3/16 (106.5)	4-3/16 (106.5)	25
TBQC400	4-11/16 (119)	4-11/16 (119)	25

### Loading Data

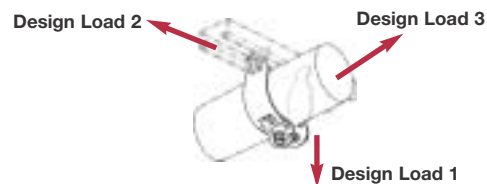

Catalogue Number	Design Load 1 Static Load Limit lb (kg)	Design Load 2 lb (kg)	Design Load 3 lb (kg)
TBQC050	200 (90)	50 (23)	50 (23)
TBQC075	200 (90)	50 (23)	50 (23)
TBQC100	200 (90)	50 (23)	50 (23)
TBQC125	200 (90)	50 (23)	50 (23)
TBQC150	200 (90)	50 (23)	50 (23)
TBQC200	200 (90)	50 (23)	50 (23)
TBQC250	350 (158)	50 (23)	50 (23)
TBQC300	350 (158)	50 (23)	50 (23)
TBQC350	350 (158)	50 (23)	50 (23)
TBQC400	350 (158)	50 (23)	50 (23)

Design Load 1 has a safety factor of 4. Design Loads 2 and 3 have a safety factor of 1.

For our complete selection, consult our Superstrut® catalogue.

# Cobra Cable and Pipe Clamp (CPC)

# Superstrut® Support Systems

## Cobra



**Clear markings on each clamp** identify the catalogue number, min./max. outer cable diameters, EMT/Rigid trade sizes, CSA and UL stamps.

One size clamp works on **equal trade sizes for both EMT and rigid conduit**.

Works with **all depths of strut - 13/16" to 3-1/4"**.

**Two hooks on the same side** make the clamp easy to install and keep conduits and cable square with strut.

**Rugged stirrup and wide saddle design** holds securely with no damage to conduit or cable.

**Suggested design load** is 200 lb (1/2" to 2"); 350lb (2-1/2" to 4"). Safety factor 4:1 (safety factor = ratio of ultimate load to the design load).

**Heavy-duty 5/16" hex bolt** with multi-driver head (Robertson square, Phillips cross-recess and slot) provides full range of installation options. Virtually any tool will work!

**Bright zinc finish** - clamps are electrogalvanized after fabrication for additional durability.



## Ordering information



Catalogue No	For EMT Trade Size	For Rigid Conduit Trade Size	Cable O.D. Range (in.)	Static Load Limit (lb) Safety Factor = 4	Quantity per Box
CPC050	1/2	1/2	0.650 - 0.890	200	100
CPC075	3/4	3/4	0.860 - 1.110	200	100
CPC100	1	1	1.100 - 1.400	200	100
CPC125	1 1/4	1 1/4	1.400 - 1.725	200	50
CPC150	1 1/2	1 1/2	1.690 - 1.980	200	50
CPC200	2	2	1.980 - 2.576	200	50
CPC250	2 1/2	2 1/2	2.576 - 3.060	350	25
CPC300	3	3	3.060 - 3.626	350	25
CPC350	3 1/2	3 1/2	3.626 - 4.126	350	25
CPC400	4	4	4.126 - 4.626	350	25

Standard material is commercial-grade, bright electrogalvanized steel. Stainless steel 316L is also available; add the suffix "SS6" to catalogue no. (i.e.: CPC050SS6). Stainless steel bolt head is hexagonal and slotted only. Not available in aluminum.

Superstrut®

For our complete selection, consult our Superstrut® catalogue.

# Superstrut® Support Systems

## Cobra Cable and Pipe Clamp (KCPC)

### King-Cobra



Superior design load capabilities for industrial applications: 350 lb for 1/2" to 2" trade sizes; 450 lb for 2-1/2" to 4" trade sizes.

- Durable one-piece, heavy-duty steel construction – designed specifically for use in industrial applications.
- Embosses on shoulder and hooks increase loading capability and durability, preventing deformation of clamps.
- Rugged stirrup provides increased strength for heavier loads, minimizing deflection.
- Wider saddle design with anti-rotation tabs distributes load evenly over a larger surface area, preventing jacket damage.
- Increased corrosion protection - GoldGalv® (yellow zinc dichromate) finish stands up to harsh industrial applications.\* Compared to conventional electrogalvanization.
- Parallel hook design keeps conduit and cable square with strut.
- Heavy-duty 5/16" hex bolt
- One size clamp works on equal trade sizes for both EMT and rigid conduit, simplifying clamp specification.



### Ordering information

Catalogue Number	For EMT Trade Size inches (mm)	For Rigid Conduit Trade Size inches (mm)	Cable Range (in.)	Quantity per Box
KCPC050	1/2	1/2	0.650-0.890	100
KCPC075	3/4	3/4	0.860-1.110	100
KCPC100	1	1	1.100-1.400	100
KCPC125	1-1/4	1-1/4	1.400-1.725	50
KCPC150	1-1/2	1-1/2	1.690-1.980	50
KCPC200	2	2	1.980-2.576	50
KCPC250	2-1/2	2-1/2	2.576-3.060	25
KCPC300	3	3	3.060-3.626	25
KCPC350	3-1/2	3-1/2	3.626-4.126	25
KCPC400	4	4	4.126-4.626	25

### Loading Data

Catalogue Number	Design Load 1 Static Load Limit lb (kg)	Design Load 2 lb (kg)	Design Load 3 lb (kg)
Safety Factor = 4			
KCPC050	350 (159)	50 (23)	50 (23)
KCPC075	350 (159)	50 (23)	50 (23)
KCPC100	350 (159)	50 (23)	50 (23)
KCPC125	350 (159)	50 (23)	50 (23)
KCPC150	350 (159)	50 (23)	50 (23)
KCPC200	350 (159)	50 (23)	50 (23)
KCPC250	350 (159)	50 (23)	50 (23)
KCPC300	450 (204)	50 (23)	50 (23)
KCPC350	450 (204)	50 (23)	50 (23)
KCPC400	450 (204)	50 (23)	50 (23)

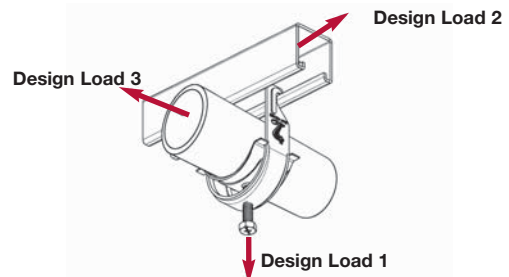

For our complete selection, consult our Superstrut® catalogue.

# Beam Clamps and Hanger Rods

# Superstrut® Support Systems

## Superstrut® Beam Clamps and Hanger Rods

### U562HDG

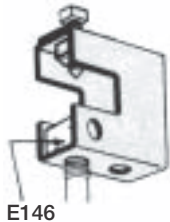

E146

Rod Size	Design Load Load/lb
1/2	800

E146 Square nut order separately. 1/2" set screw included.

For 20° swivel application use ES145-1/2 nut.

### UM562HDGC

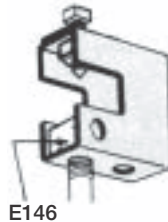

E146

Rod Size	Design Load Load/lb
1/2	1200

E146 Square nut order separately. 1/2" set screw included.

For 20° swivel application use ES145-1/2 nut.

### US562HDGC

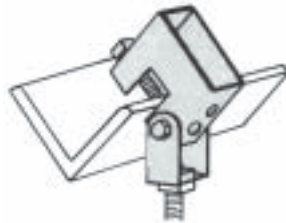

Rod Size	Design Load Load/lb
1/2	800

1/2" set screw included.

### U568



Cat. no.	Beam Flange Width	A
U568-3EG	6	9
U568-4EG	9	12
U568-5EG	12	15

16 ga. material

### U514HDGC



3/8" x 1-1/2" set screw included.

Design Load 750 lb/per pair

### U515HDGC



For all "A" series channel. 1/2" x 1-1/2" set screw included.

Design Load 800 lb

### ES145

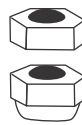

Cat. No.	Size
ES145-3/8EG	3/8
ES145-1/2EG	1/2

### E146



Cat. No.	Size
E146-1/4EG	1/4
E146-5/16EG	5/16
E146-3/8EG	3/8
E146-1/2EG	1/2
E146-5/8EG	5/8

### H104



Standard length, 10 ft

Also available in stainless steel (304 and 316) in length of 6 ft

#### NATIONAL COARSE THREAD

Cat. No.	Size	Threads per inch	Design Load lb
H104-1/4x10EGC	1/4	20	150
H104-3/8x10EGC	3/8	16	610
H104-1/2x10EGC	1/2	13	1130
H104-5/8x10EGC	5/8	11	1810
H104-3/4x10EGC	3/4	10	2710
H104-7/8x10EGC	7/8	9	3770
H104-1x10EGC	1	8	4960

### H119

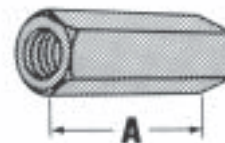

Order by product number, rod size, and finish. Example: H119-1/2EGC

Rod Size	A
1/4	7/8
5/16	7/8
3/8	1-1/8
1/2	1-1/4
5/8	2-1/8
3/4	2-1/4
7/8	2-1/2
1	2-1/4

Superstrut®

Finished & Materials: Gold Galv. dichromate (no suffix), Electrogalvanized (EG), Hot dipped Galvanized (HDGC), Stainless Steel Type 316 (SS6C)

For our complete selection, consult our Superstrut® catalogue.

# Superstrut® Support Systems

## Design Applications Mechanical Support

### Example: 1

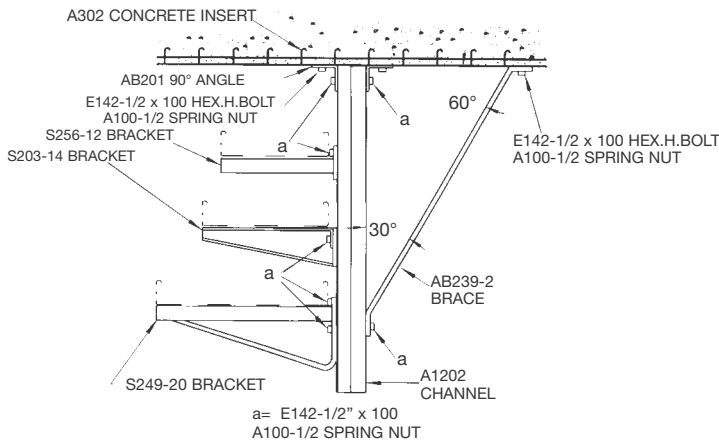

Suspended column, carrying brackets, braced to the ceiling.

### Example: 2

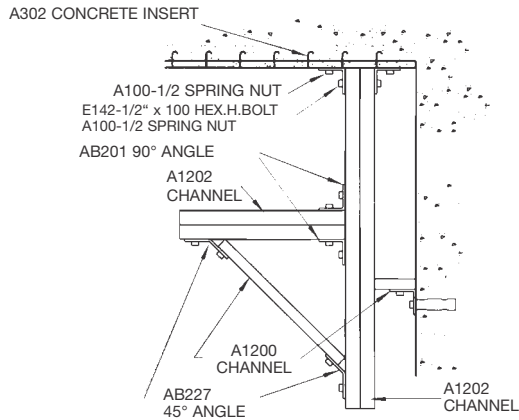

Suspended column, holding bracket and console braced to wall.

### Example: 3

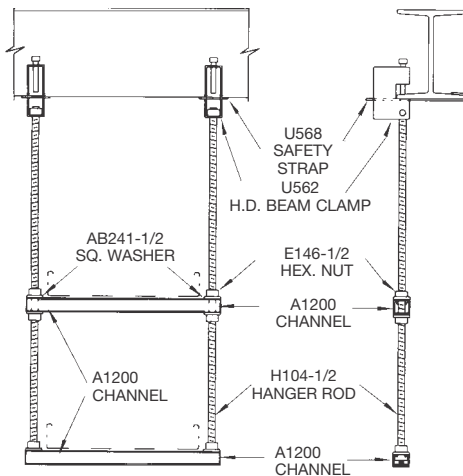

Trapeze, T&B channels are used as cross members.

### Example: 4

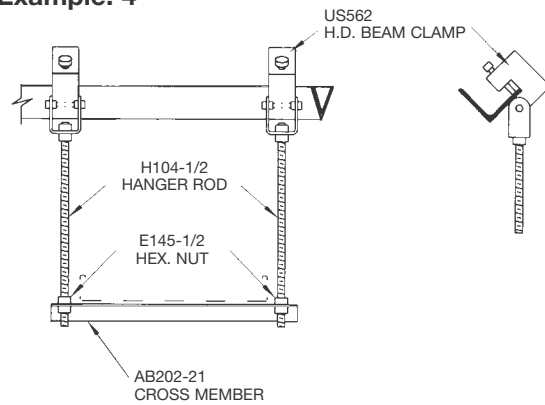

Sketch depicts the use of beam clamps on slanted beams.

### Example: 5

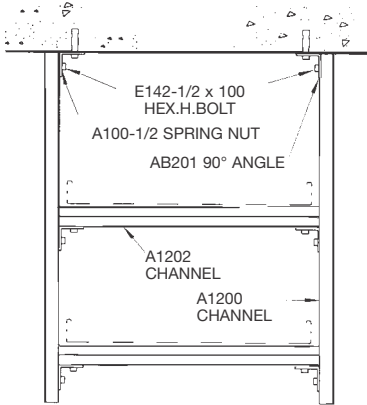

Trapeze, constructed from T&B channels, fittings. The use of spot inserts is shown.

### Example: 6

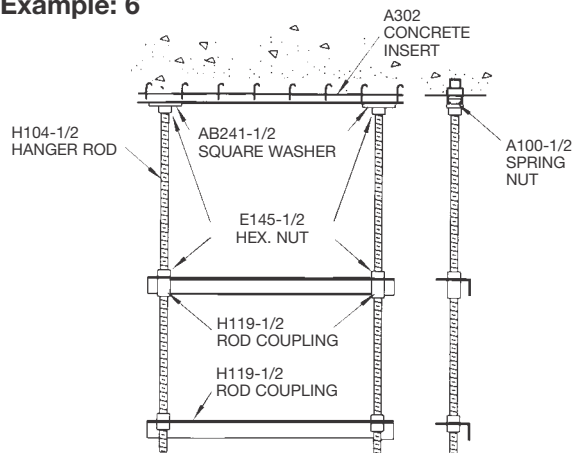

Trapeze, using T&B hanger rods, cross members.

For our complete selection, consult our Superstrut® catalogue.

# Design Applications Mechanical Support

# Superstrut® Support Systems

**Example: 7**

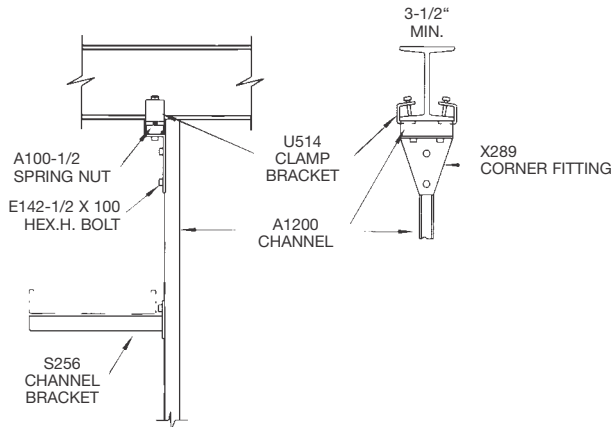

\* NOTE: BRACE SHOULD BE USED FOR LENGTHS GREATER THEN 30"

**Single-sided bracket application**

**Example: 8**

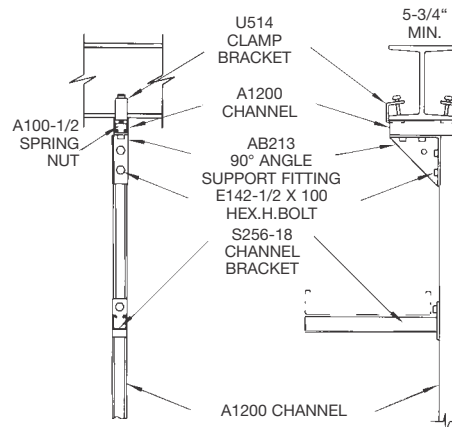

**Single-sided bracket application**

**Example: 9**

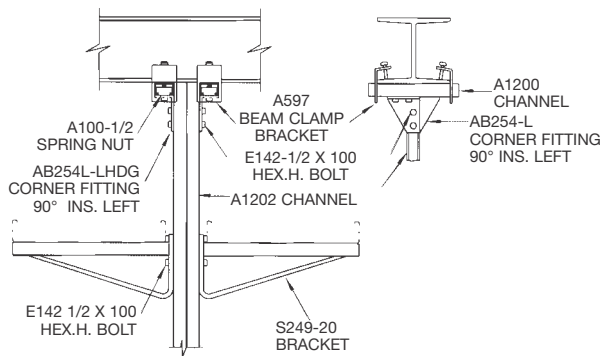

**Two-sided heavy duty application**

**Example: 10**

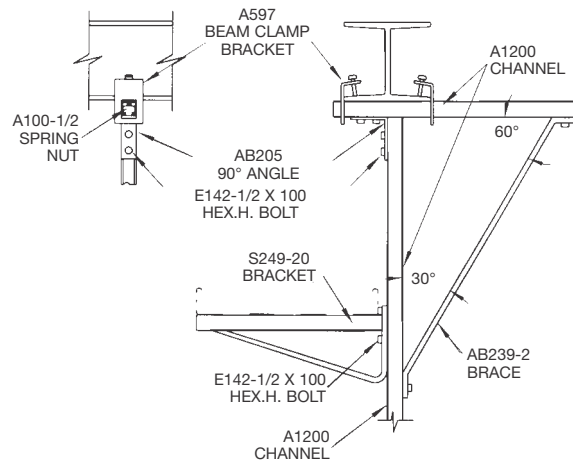

**Heavy duty bracket application**

**Example: 11**

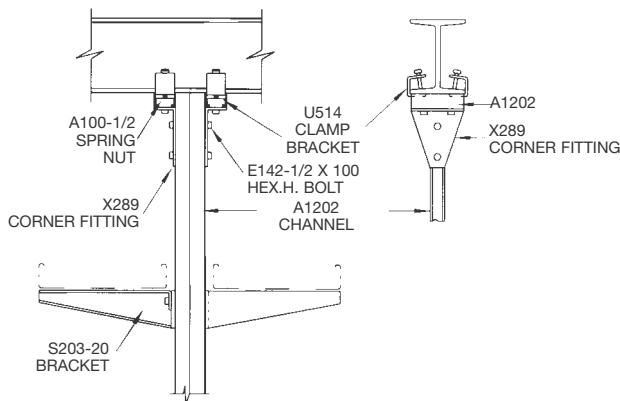

**Brackets parallel to beam**

**Example: 12**

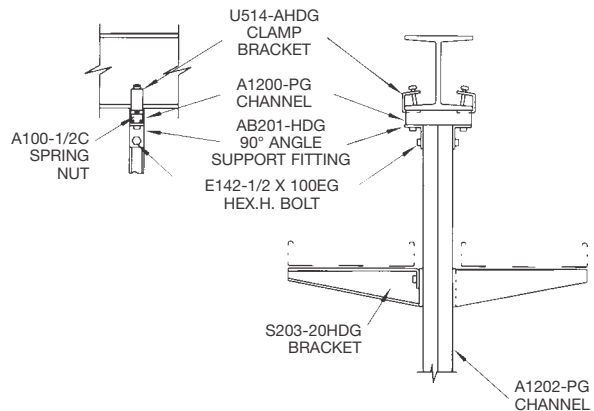

**Brackets perpendicular to beam**

For our complete selection, consult our Superstrut® catalogue.

Superstrut®