

EXACTECH | KNEE

Operative Technique

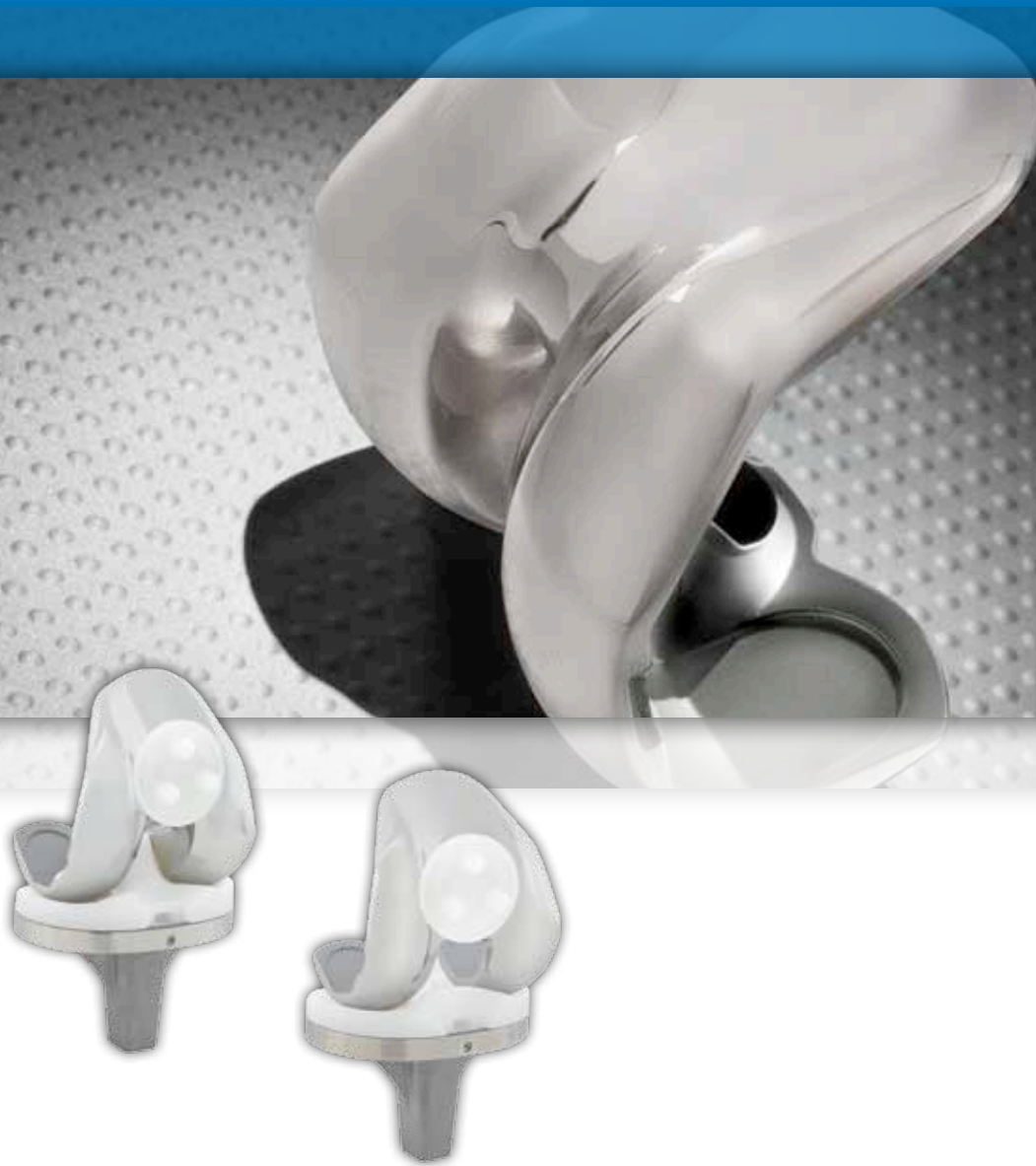

OPTETRAK[®]
LOGIC[®]
CR/PS Low Profile
Instrumentation (LPI[®])

TABLE OF CONTENTS

INTRODUCTION	1
DESIGN RATIONALE	1
PRE-OPERATIVE PLANNING	1
OPERATIVE TECHNIQUE OVERVIEW	2
DETAILED OPERATIVE TECHNIQUE	4
APPROACH AND EXPOSURE	4
PREPARATION OF THE FEMUR.....	5
Step 1: Opening the Intra-medullary Canal.....	5
Step 2: Distal Femoral Resection	6
Step 3: Sizing of Femoral Component.....	7
Step 4: Rotation of Femoral Component.....	8
Step 5: Resection of Anterior, Posterior and Chamfer Femoral Bone.....	8
Step 6: Femoral Notch Preparation.....	9
PREPARATION OF THE TIBIA	10
Assembly of the Extra-medullary Tibial Alignment Guide.....	10
Placement of the LPI Extra-medullary Tibial Alignment Guide.....	11
TRADITIONAL TIBIAL APPROACH: RECOMMENDED FOR PS KNEES.....	12
CRTIBIAL RESECTION: POSTERIOR CRUCIATE REFERENCING TECHNIQUE	13
Step 1: Identification of the Posterior Cruciate Ligament (PCL)	
Insertion Points.....	13
Step 2: Placement and Distal Alignment	
of the Extra-medullary Alignment Guide	13
Step 3: Determination of Posterior Tibial Slope.....	13
Step 4: Determination of Tibial Resection Depth	13
Step 5: Securing Tibial Resection Guide to Tibia and Final Checking	14
PREPARATION OF THE PATELLA	14
FINAL PROTHESISTRIAL CHECK.....	15
Trial Placement	15
Alignment Check	15
Stability Check	15
PS Surgical Approach	15
CR Surgical Approach	16
Motion Check.....	16
Patellar Tracking Check.....	17
FINAL PREPARATION OF THE TIBIA	17
IMPLANTATION OF FINAL COMPONENTS	19
Step 1: Final Bone Preparation.....	19
Step 2: Implantation of the Tibial Prosthesis.....	20
Step 3: Implantation of Femoral Component	21
Step 4: Polymerization of Cement	22
Step 5: Implantation of Patellar Component.....	22
Step 6: Installation of Tibial Polyethylene Insert	
(Modular Tibial Component Only).....	23
FINAL CHECK AND CLOSURE	23
DESIGN SPECIFICATIONS	24
PTS ANNEX	24
INSTRUMENT LISTING	26

Optetrak Logic® is an advanced approach to total knee replacement that introduces modern design features and intuitive instrumentation while building on the wisdom of a strong design lineage.

INTRODUCTION

Total knee replacement surgery has been one of the most successful orthopaedic procedures during the past three decades. Advanced surgical techniques and implant design improvements have been two of the factors responsible for that success. Exactech developed Low Profile Instrumentation (LPI®) to provide user-friendly instruments that achieve reproducible bone preparation and limb alignment and allow for superior visualization and accessibility while keeping soft tissue disruption to a minimum.

Based on more than 30 years of clinical results from Hospital for Special Surgery, Exactech's comprehensive knee systems address your concerns for contact stress, patellar tracking, polyethylene wear, joint stability and bone preservation with streamlined instrumentation that allows you to work quickly and efficiently.

DESIGN RATIONALE

Exactech's LPI instrumentation is not a radical departure from the classic Optetrak instrumentation. It is, rather, an optimized system of instruments that can be used in total knee replacement surgery, regardless of the size of the incision or method of handling soft tissues. The system's easy-to-use instrumentation allows you to work quickly and efficiently with streamlined solutions for your preferred surgical technique.

PRE-OPERATIVE PLANNING

The mechanical goal of total knee surgery is to effectively restore the normal alignment of the affected limb. Normal alignment implies that the mechanical axis, from the center of the femoral head to the center of the ankle, passes through the center of the knee joint. The implant should be positioned perpendicular to this axis. Correct positioning is usually accomplished by performing the tibial cut perpendicular to the frontal plane, usually with some degree of posterior slope and by cutting the distal femur between 5-7 degrees of valgus from the anatomical axis (*Figure 1*). Templating is done in both the frontal and sagittal planes to estimate the implant size for both the femur and tibia.

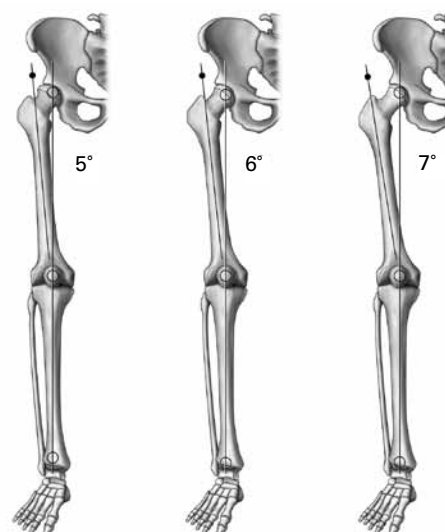
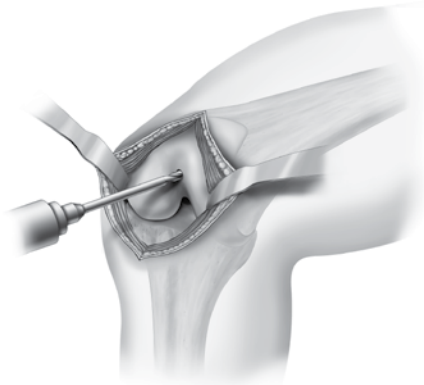

Figure 1
Different Alignment Angles of the
Mechanical Axis of the Lower Limb

OPERATIVE TECHNIQUE OVERVIEW



1

**Enter Intra-medullary Canal
with the IM Pilot Drill**

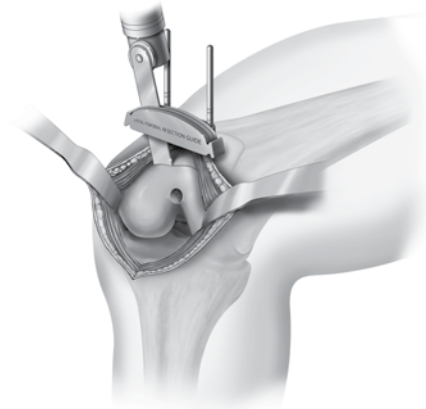

2

Perform Distal Femoral Resection



3

Determine Femoral A/P Size

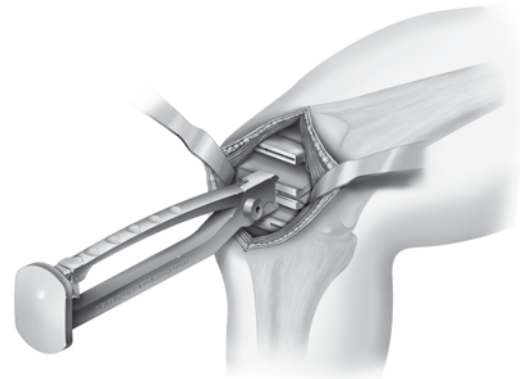

4

**Prepare Femur with Femoral
Finishing Guide**

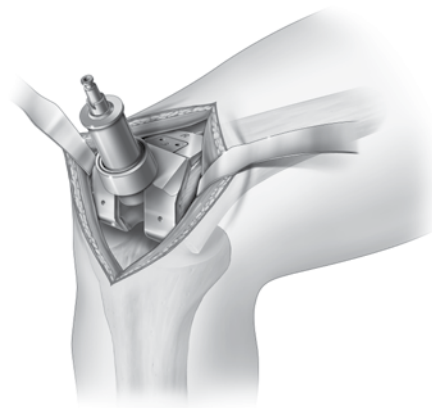

5

Prepare PS Notch with Notch Cutting Guide*



6

**Prepare Tibia with Extra-medullary
Alignment Guide and
Perform Tibial Resection**

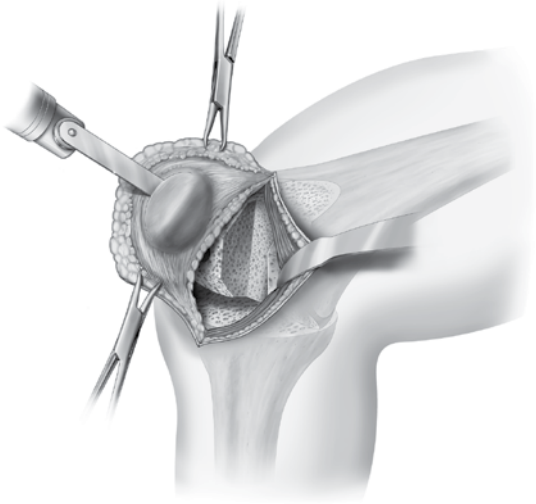

7

Prepare Patella



8

**Assemble Trials and Perform
Final Stability Assessment**

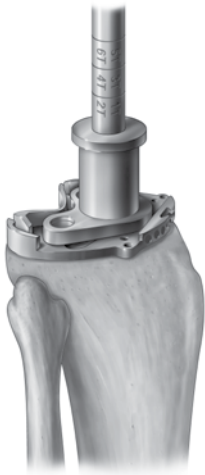

9

Drill Pilot Hole on Tibia



10

Prepare Tibia with Fit Tamp



11

Implant Final Components

DETAILED OPERATIVE TECHNIQUE

APPROACH AND EXPOSURE

Setup is important, and because the degree of flexion and extension of the knee must be adjusted and optimized for each step of the procedure, an adjustable foot holder, an extra assistant or placement of multiple bolsters on the surgical table is helpful. Although a great deal of traditional arthroplasty is performed with the knee in a flexed or hyperflexed position, the use of reduced exposure is often facilitated by placing the knee in a more extended position, thereby relaxing the anterior soft tissue envelope. The landmarks shown in this procedure performed with the Optetrak Low Profile Instrumentation (LPI) are the same ones used during standard incision total knee replacement surgery, including the shape of the patella, the anterior tibial tuberosity and the joint line (Figure 2).

An 8-10cm incision is made, beginning at or 1cm above the superior pole of the patella and extending 2cm distal of the joint line. Fascia adhesions of the quadriceps muscle to the tissues are freed with blunt and sharp dissection, which facilitates subsequent soft tissue and patellar mobilization.

The joint is then entered through one of three approaches: subvastus, midvastus or rectus femoris split (Figure 3).

During a *subvastus* approach, the arthrotomy is capsular only, preserving the entire extensor mechanism insertion onto the patella. A fascia rim is preserved bordering the vastus medialis obliquus (VMO) to assure retractors are placed against this rim and not directly on the muscle over the quadriceps itself. The reflected retinaculum contains the medial patellofemoral ligament and must be tagged, retracted and protected. The medial capsular reflection under the VMO is released, allowing the quadriceps to be displaced laterally.

In the *midvastus* approach, an incision is made between the vastus medialis and the vastus medialis obliquus, beginning at the superior and medial corner of the patella. The muscle is split bluntly in line with its fibers, while the underlying fascia is split sharply by pushing scissors in a similar direction. This 2cm split can be safely extended for 3-4cm, although this is rarely necessary.

The *rectus femoris split* approach is simply a shortened conventional arthrotomy. Of course, all approaches can be and are being used successfully. To optimize the ease and efficiency of the procedure in patients with increased obesity, increased thigh muscularity, increased distal femoral dimension, patella baja, a more horizontal VMO insertion, a decreased extensor mechanism mobility, or in any case when difficult exposure is anticipated, it is recommended to move away from the subvastus toward either the midvastus, or on occasion, the rectus split approach.

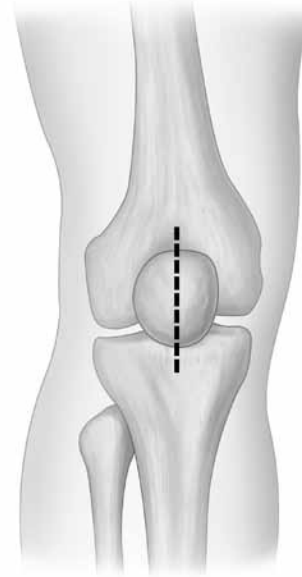
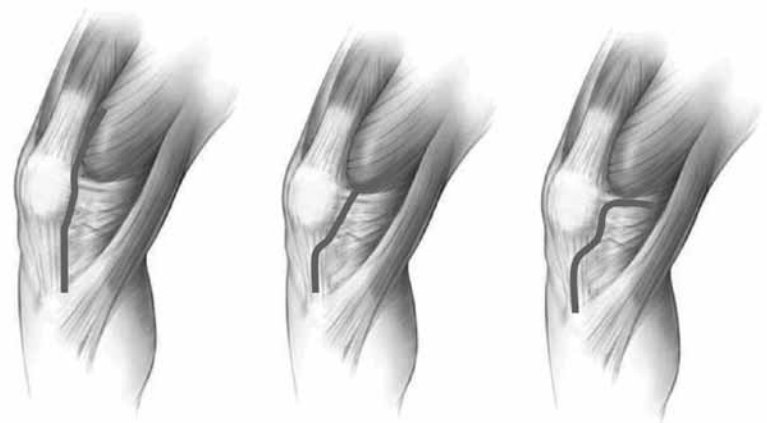

Figure 2

Skin Incision. Bony Landmarks Can Be Recognized Underneath the Skin



Rectus Femoris Split

Mini-midvastus

Subvastus

Figure 3

Enter Joint Through One of These Three Approaches

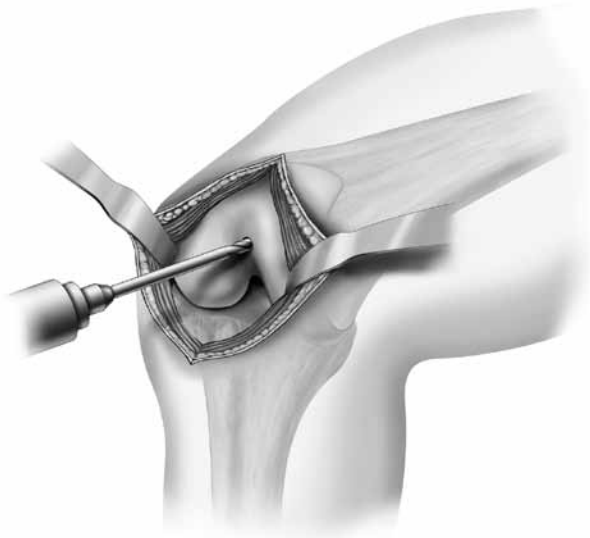

Figure 4
Enter Intra-medullary Canal
with the IM Pilot Drill

The exposure is expanded medially using an angled narrow and sharpened Hohmann Retractor. A second Hohmann Retractor is used to push the patella laterally. The patella is not everted. Initially, exposure is limited to the central and medial compartments. However, with some extension, the entire joint can be delivered into the wound. An interesting paradox exists with regard to both the number of retractors and the force of retraction: less is more. Retraction for exposure in one area will result in a proportionate and obligate reduction of exposure in another. Using fewer and narrower angled retractors and pulling reciprocally rather than forcefully is recommended. The retractor and leg position must be constantly adjusted and optimized for each step of the procedure.

Exposure during the remainder of the procedure is achieved by moving the soft tissue window. The anterior cruciate ligament (ACL) and the anterior horns of both menisci are resected. The superficial layers of the medial collateral ligament (MCL) are subperiosteally elevated, and a meticulous resection of osteophytes is performed. This not only helps to mobilize the unresected patella into the lateral gutter of the knee, but also relieves tension off the lateral and medial collateral ligaments.

A very important precaution in every small incision procedure is to keep the suprapatellar pouch as intact as possible; this decreases the incidence of short-term post-operative pain and long-term scar formation and limited flexion.

PREPARATION OF THE FEMUR

Step 1: Opening the Intra-medullary Canal

The **Intra-medullary (IM) Pilot Drill** should be used to drill a hole in the distal femur coaxially with the femoral endosteal canal (*Figure 4*). The entry point for this drill is located in the intercondylar groove 5-10mm anterior to the intercondylar notch. This entry point may be more accurately located by one of these two methods:

1. palpating the femur in the cephalad portion of the exposure, or
2. opening the cortex anterior to the femoral notch with a rongeur, osteotome or gouge.

It may be beneficial to enlarge the hole in the distal femur while drilling so that a slightly malpositioned entrance point does not affect the alignment of the **T-Handle Intra-medullary Rod**. After the canal has been opened with the IM Pilot Drill, the T-Handle IM Rod should be inserted into the femoral canal to be sure it passes easily. The T-Handle IM Rod should then be removed from the canal.

Step 2: Distal Femoral Resection

To set the distal femoral valgus alignment of the femoral cut, insert the **LPI Intra-medullary Alignment Guide Bushing** into the **LPI Intra-medullary Alignment Guide** with the proper side (left or right) facing anteriorly (*Figure 5*). The release button underneath the rectangular hole in the IM Alignment Guide should be pressed, allowing the IM Alignment Guide Bushing to slide into it.

Place the T-Handle IM Rod through the LPI IM Alignment Guide Bushing and introduce the assembly onto the distal femur (*Figure 6*). The IM Alignment Guide can be aligned parallel to the transepicondylar axis, although alignment is not crucial at this point.

Affix the **LPI Distal Link** to the **LPI Distal Femoral Resection Guide** (*Figure 5*); this makes placement of the resection guide underneath the soft tissue easier (*Figure 7a*).

The distal femoral resection will be influenced by the degree of flexion contracture documented during pre-operative examination. Adjusting the depth of distal femoral resection to the degree of flexion contracture is important to ease balancing the flexion and extension gaps. The Distal Femoral Resection Guide features different pinholes that allow for adjustment of the resection depth in 2mm increments.

Pin the Distal Femoral Resection Guide in the nominal holes (*Figure 7b*). Performing the distal femoral cut through the standard slot resects 10mm from the distal femur (*Figure 7b*); the alternative slot resects 3mm more (13mm). The block may be shifted to the second pin location for an additional 2mm resection. The Distal Femoral Resection Guide also features two extra holes for cross pins that enhance the fixation of the Resection Guide to the bone and make it more stable during the resection.



Figure 5
Assemble the Femoral Alignment Instruments for Distal Femoral Resection

1. Bushing
2. IM Alignment Guide
3. Distal Link
4. Distal Femoral Resection Guide

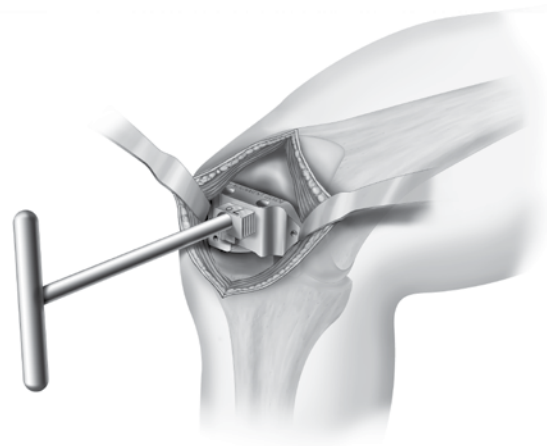

Figure 6
Align Distal Femoral Cutting Instruments



Figure 7a
Assemble Distal Femoral Resection Guide to Distal Link

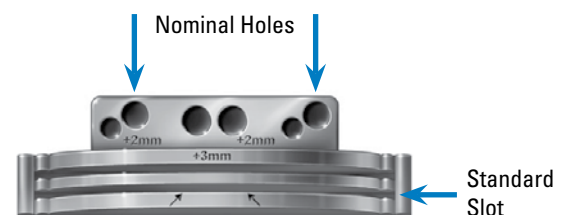

Figure 7b
Pin Distal Resection Guide in Nominal Holes

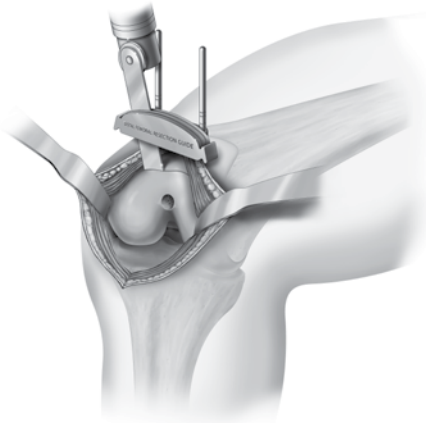

Figure 8
Perform Distal
Femoral Resection

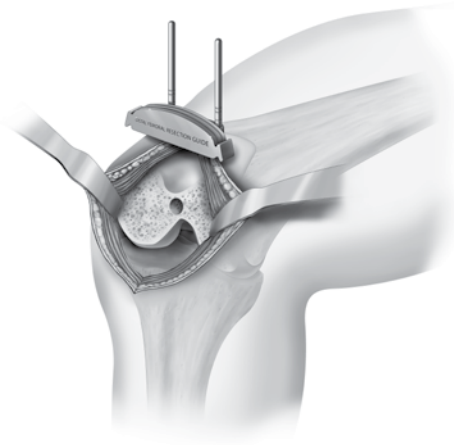

Figure 9
Resected Distal Femur



Figure 10
Place Femoral A/P Sizer on
Distal Femur

Remove the T-Handle, Alignment Guide and Distal Link. The quadriceps and skin must be retracted proximally and the knee slightly extended before performing the distal femoral resection.

The distal femoral resection is performed, always protecting the medial and lateral collateral ligaments (*Figure 8*). The medial condyle should be resected first. The surgical window should now be mobilized to the lateral compartment of the knee to perform the lateral condylar resection (*Figure 9*).

The Distal Femoral Resection Guide should now be removed. Bone remnants may now be removed with a rongeur, a saw or a bone file. To be sure that the resected surfaces of the medial and lateral femoral condyles are coplanar, a flat cutting block may be used to check the cuts.

Step 3: Rotation of Femoral Components

Templating is essential in small incision procedures, since the surgeon has a limited view of the anterior aspect of the distal femur. Adjust the **LPI Femoral A/P Sizer** to the templated size or set to 3 to begin. External femoral rotation is determined by inserting the **LPI Femoral A/P Sizer Drill Guide Bushing** into the LPI Femoral A/P Sizer. The LPI instruments feature different Drill Guide Bushings, including 0- and 3-degree options for both right and left. This handle does not interfere with the Drill Guide.

Step 4: Sizing the Femoral Component

The LPI Femoral A/P Sizer should be placed flush against the resected distal surface of the femur. The **LPI Offset A/P Sizer Handle** is provided to facilitate insertion and manipulation of the A/P sizer (*Figure 10*).

The posterior feet of the Sizer should be inserted under the posterior femoral condyles. If a posterior condylar defect is present, the LPI Femoral A/P Sizer should be rotated to a position that accommodates the defect. Due to the size of the incision and the medial arthrotomy, the A/P Sizer could be placed slightly medial on the femoral bone. The Femoral A/P Sizer is adjusted to the femoral size. Slide the tip of the A/P Sizer Stylus underneath the quadriceps and into the suprapatellar pouch. The surgeon palpates the position of the tip of the Stylus Pointer, trying to make it rest in the midportion of the femoral metaphysis. It is advisable to choose a smaller femoral size if the A/P Sizer is measuring between sizes. The surgeon may correlate the template size with the size given by the Femoral A/P Sizer as a size confirmation.

Verify that the A/P Sizer is flat against the distal femoral surface, and drill holes with the **LPI Collar Drill** (Figure 11).

Step 5: Resection of Anterior, Posterior and Chamfer Femoral Bone

The **LPI Femoral Finishing Guide** should be positioned onto the distal femur using the **LPI Finishing Guide Impaction/Extraction Handle** (Figure 12).

The size of the Femoral Finishing Guide has been determined previously with the LPI Femoral A/P Sizer. The Femoral Finishing Guide has two pegs that align with the pre-drilled rotation holes and can be pinned on the medial and lateral sides, as well as in the center with cross pins to enhance fixation stability. The anterior and posterior cuts are performed followed by the chamfer cuts. Once the cuts on the distal femur have been completed, the Femoral Finishing Guide should be removed and the resected bone excised.

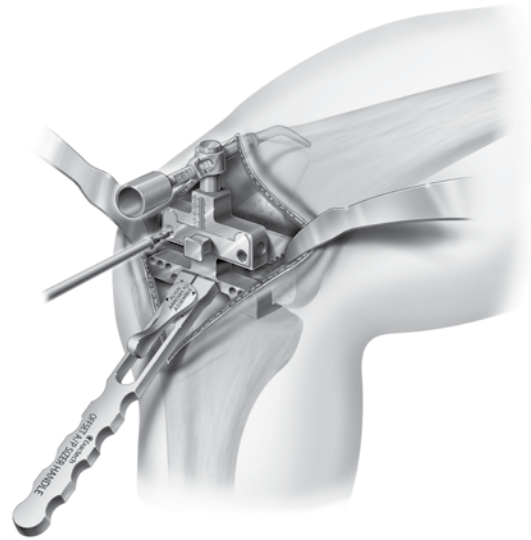

Figure 11

Verify Placement of A/P Sizer and Drill Rotational Alignment Holes

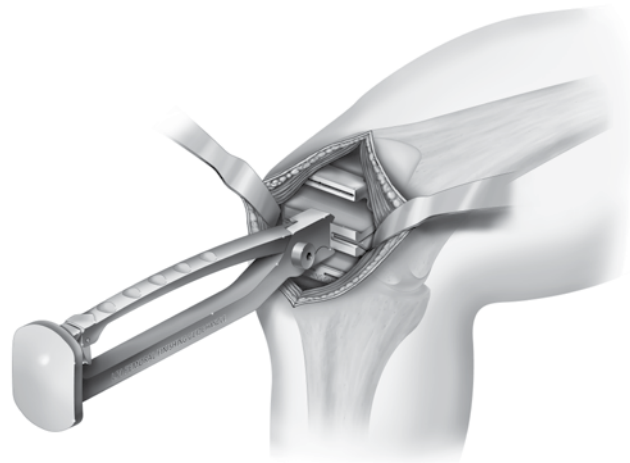

Figure 12

Position Femoral Finishing Guide

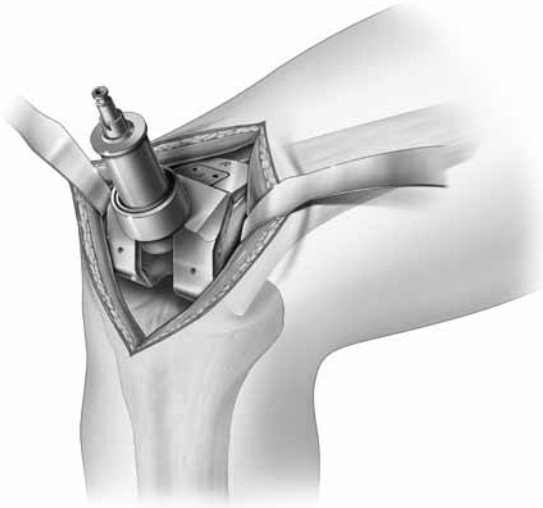

Figure 13
Prepare PS Notch
with Cutting Guide

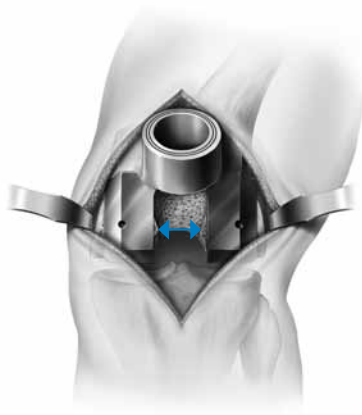

Figure 14
Remove Bone Remnants from
the Distal Femur

If an Optetrak Logic CR implant is selected, the femoral preparation is complete for now. Proceed to the next section, Preparation of the Tibia.

If an Optetrak Logic PS implant is selected, proceed to Step 6 to complete the femoral notch preparation.

Step 6: Femoral Notch Preparation

Select the **Logic PS Femoral Notch Cutting Guide** and the **Logic PS Femoral Notch Cutter** that correspond to the previously determined femoral component size.

Rotate the anterior flange of the Notch Cutting Guide to the appropriate side that corresponds to the operative knee (left or right), place on finished cuts and affix the Notch Cutting Guide onto the distal femur with fixation pins.

Note: While pinning, be sure the Notch Cutting Guide maintains contact with the distal and anterior chamfer resections. Affix the two distal pins, then affix one pin in the offset medial anterior flange.

Attach the Notch Cutter to a power drill. With the knee in flexion, introduce the Notch Cutter into the Notch Cutting Guide, making sure that the drill is set on "drill" setting. Once the teeth on the Notch Cutter have cleared the black bushing and before the teeth contact the bone, activate the drill. Apply pressure to the Notch Cutter as it travels posteriorly and ream until the Notch Cutting Guide prevents the Notch Cutter from further travel (Figure 13).

Turn the power drill off, and remove the Notch Cutter from the Cutting Guide. **Note:** Be sure not to activate the drill while removing the Notch Cutter in order to prevent the cutting teeth from scoring the black bushing.

Due to the cylindrical shape of the Notch Cutter, it is necessary to remove any existing bone remnants from the distal femur (Figure 14). It is recommended to use a sagittal saw to remove the bone remnants, aligning the saw to the inner surfaces of the Notch Cutting Guide and trim the medial and lateral sides of the notch. Remove the Notch Guide after all cuts are performed. Preparation for the Optetrak Logic PS femoral component is complete.

PREPARATION OF THE TIBIA

The tibia can be prepared using either the LPI extra-medullary preparation method or the LPI intra-medullary preparation method.

Note: See the *Intra-medullary Tibial Preparation Operative Technique Addendum* for preparation details.

Assembly of the Extra-medullary Tibial Alignment Guide

The proximal tibial resection can be aligned and performed using the **LPI Extra-medullary Tibial Alignment Guide** (LPI Ankle Clamp Base, LPI Ankle Clamp Upright, LPI Tibial Resector Shaft and LPI Tibial Resection Guide) (*Figure 15*).

To assemble the Extra-medullary Tibial Alignment Guide, slide the shaft of the **LPI Ankle Clamp Base** into the lower end of the **LPI Ankle Clamp Upright**. The markings on the LPI Ankle Clamp Base should face upward, and the push button on the LPI Ankle Clamp Upright should face away from the Ankle Clamp. While pressing the button on the LPI Ankle Clamp Upright, assemble the upright onto the shaft of the LPI Ankle Clamp Base (*Figure 16*).

Position the lever on the proximal end of LPI Ankle Clamp Upright pointing down. Press the button on the proximal end of the LPI Ankle Clamp Upright and insert the **LPI Tibial Resector Shaft** into the LPI Ankle Clamp Upright with the teeth facing posteriorly, or away from the lever and button (*Figure 17*).

When the button is pressed, the **LPI Tibial Resector Shaft** will be able to move within the LPI Ankle Clamp Upright. When the button is released, the position of the LPI Tibial Resector shaft is locked.

Note: The lever can be shifted to either side to disengage the push button locking mechanism, allowing the LPI Tibial Resector Shaft to move freely.

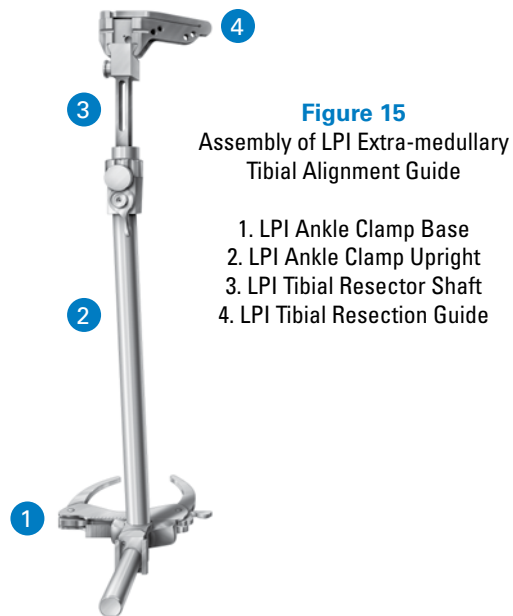

Figure 15
Assembly of LPI Extra-medullary Tibial Alignment Guide

1. LPI Ankle Clamp Base
2. LPI Ankle Clamp Upright
3. LPI Tibial Resector Shaft
4. LPI Tibial Resection Guide

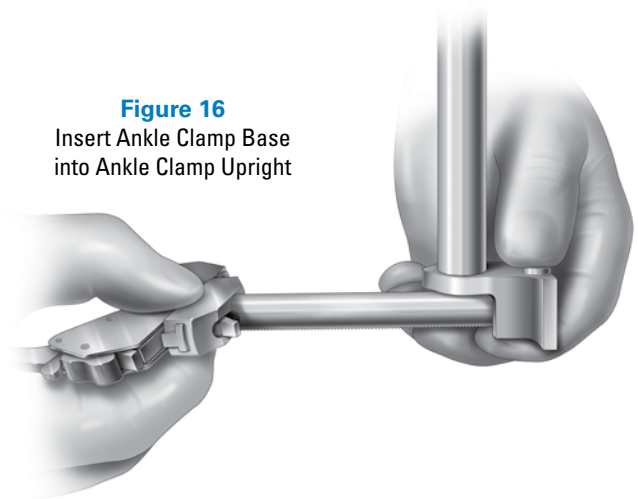

Figure 16
Insert Ankle Clamp Base into Ankle Clamp Upright

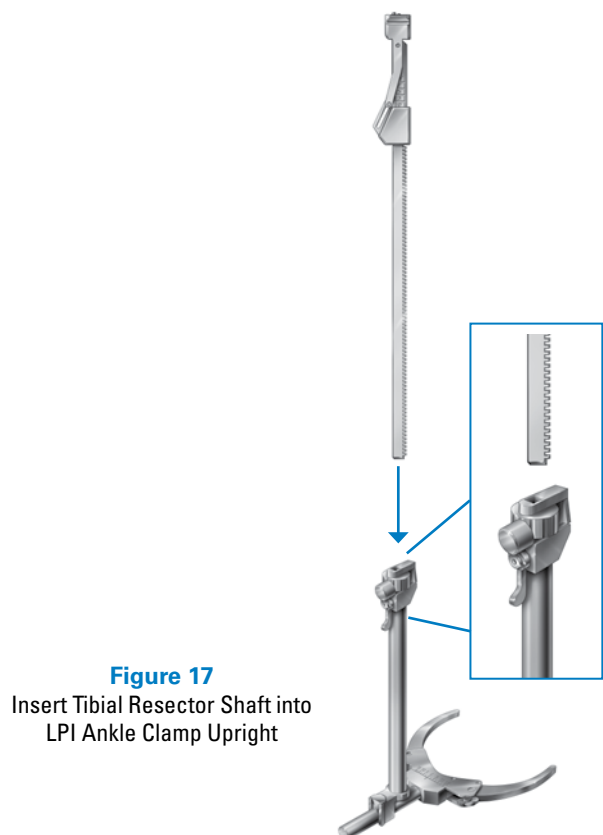

Figure 17
Insert Tibial Resector Shaft into LPI Ankle Clamp Upright

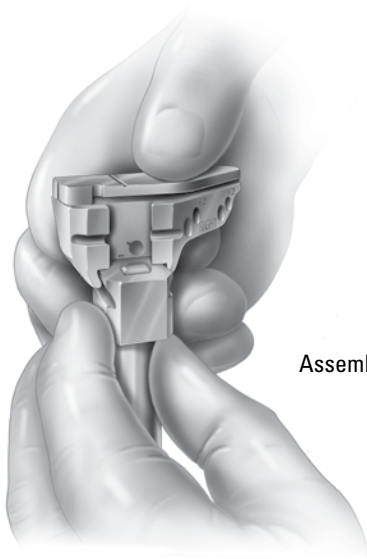

Figure 18
Assemble Tibial Resection Guide and
Tibial Resector Shaft



Figure 19
Placement of Extra-medullary
Tibial Alignment Guide

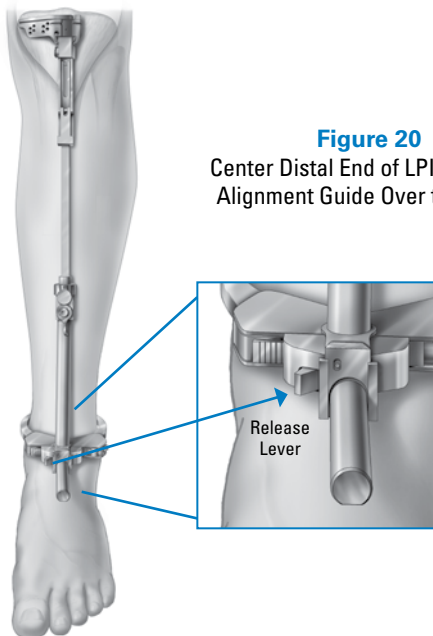

Figure 20
Center Distal End of LPI EM Tibial
Alignment Guide Over the Ankle

Attach the **LPI Tibial Resection Guide** to the proximal end of the LPI Tibial Resector Shaft by pressing the button on the LPI Tibial Resector Shaft and sliding the LPI Tibial Resection Guide onto the dovetail, from posterior to anterior (*Figure 18*).

Placement of the LPI Extra-medullary Tibial Alignment Guide

Place the LPI EM Tibial Alignment Guide on the front of the tibia and clamp the spring-loaded arms around the ankle in the supra-malleolar position (*Figure 19*).

The distal end of the LPI EM Tibial Alignment Guide should be centered over the ankle joint. In most instances, the LPI Ankle Clamp Base will read 2-5mm medial when properly centered on the ankle. The second toe is another common landmark for the distal alignment of the Ankle Clamp. The position of the LPI Ankle Clamp Base can be adjusted by pressing the release lever and shifting the Guide medially or laterally (*Figure 20*).

Landmarks to center the LPI Tibial Resection Guide proximally include the medial 1/3 of the anterior tibial tuberosity and tibial spine. In the sagittal plane, the LPI EM Tibial Alignment Guide should be aligned parallel to a line extending from the center of the knee joint to the center of the ankle joint.

The posterior slope of the LPI Tibial Resection Guide can be adjusted by positioning the proximal end of the Resector Shaft to the desired degree of posterior slope (0, 3, 5, 7 or 10 degrees). If the surgeon prefers, posterior slope may also be adjusted by repositioning the LPI Ankle Clamp Upright on the LPI Ankle Clamp Base. Positioning the LPI Ankle Clamp Upright more anterior onto the base will add slope to the LPI Tibial Resection Guide, while positioning it more posterior will reduce slope.

The next two sections outline the tibial resection technique for the Optetrak Logic PS and Optetrak Logic CR systems, respectively.

TRADITIONAL TIBIAL APPROACH:

RECOMMENDED FOR PS KNEES

Once the appropriate slope has been dialed in, the **LPI Fixed Tibial Stylus** should be placed in the cutting slot of the LPI Tibial Resection Guide. The resection level should be adjusted so that the LPI Fixed Tibial Stylus references the proximal tibia plateau.

The resection level of the LPI Tibial Resection Guide can be adjusted by pressing the button on the proximal end of the LPI Ankle Clamp Upright. Micro adjustments to the resection level can be made by rotating the knob on the proximal end of the LPI Ankle Clamp Upright (*Figure 21*).

To set resection depth, use the 10mm side of the Stylus when referencing the most normal plateau and the 1mm side when referencing the most affected plateau (*Figure 22*).

The **LPI Cut Line Predictor** may be used to evaluate the tibial resection level. Once the LPI Tibial Resection Guide is adjusted to the desired resection level and slope, it can be pinned in position.

The alignment of the resection guide can be verified by locking the **Mauldin Multi-Tool** into the anterior recess of the block and inserting the drop rod into the holes of the Mauldin Multi-Tool. The drop rod can be used to assess alignment with extra-medullary landmarks (*Figure 23*). Proceed to resect the proximal tibia.

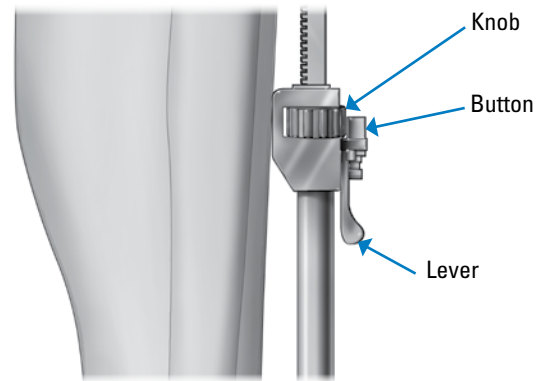

Figure 21
Adjust Resection Level

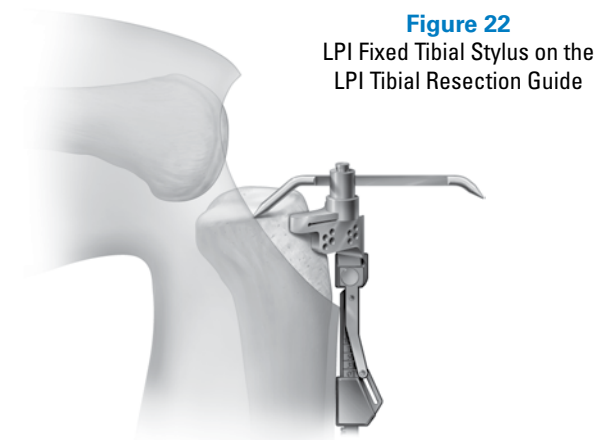

Figure 22
LPI Fixed Tibial Stylus on the
LPI Tibial Resection Guide

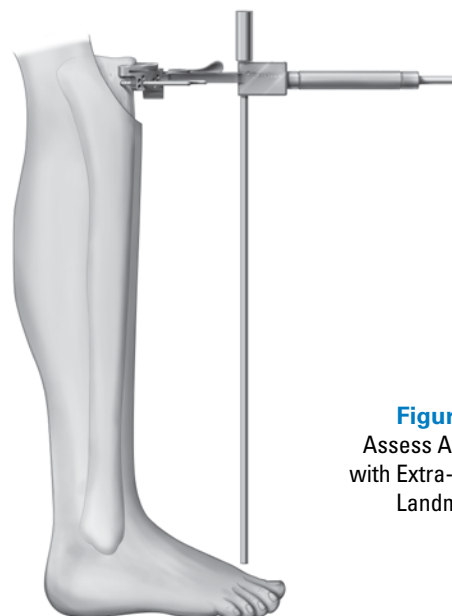

Figure 23
Assess Alignment
with Extra-medullary
Landmarks

Figure 24
Placement of No-Touch
PCL Retractor

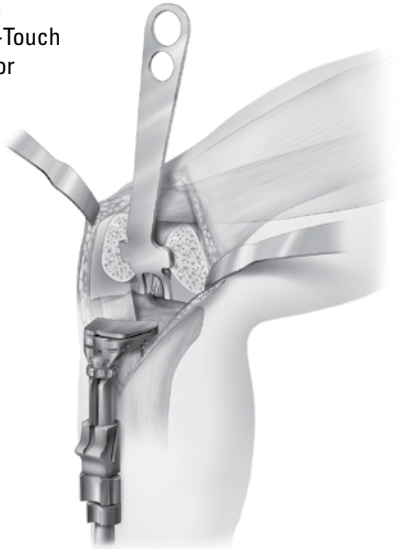
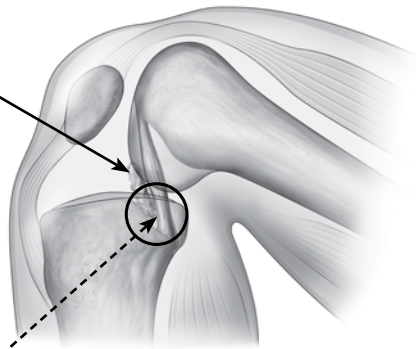

Figure 25
Clear Soft Tissues
around PCL



Place Tip of PCL Stylus
at Footprints of PCL

Figure 26a

Determine Tibial Resection Depth

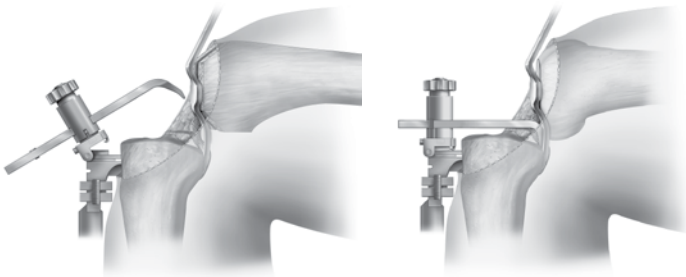

CR TIBIAL RESECTION: POSTERIOR CRUCIATE REFERENCING TECHNIQUE (PCRT)

Note: Standard CR inserts are available for a more traditional tibial approach.

Step 1: Identification of the posterior cruciate ligament (PCL) Insertion Points

Place the **No-Touch PCL Retractor** behind the tibia with one prong medial and one prong lateral to the PCL (*Figure 24*). Subluxate the posterior margin of the tibia anterior to the femur. At this point, the No-Touch PCL Retractor should protect both the PCL and the resected surface of the distal femur. Connective and scar tissues are usually present around the anterior aspect of the tibial insertion of the PCL. These tissues are intimately attached to the fibers of the PCL. Proceed to release the tissues around the anterior portion of the PCL, until the fibers of the PCL are recognized at their insertion into the posterior tibia (*Figure 25*).

Identification of the PCL fibers and release of the scar tissue surrounding the PCL is essential at this point. This is the anatomical landmark that will be used to reference the proximal tibial resection.

It is also advisable to resect any remaining posterior horns of both menisci and menisco-femoral ligaments at this time.

Step 2: Placement and Distal Alignment of the Extra-medullary Alignment Guide

The proximal tibial resection can be aligned and performed using the **LPI Extra-medullary Tibial Alignment Guide**. For assembly and positioning, please refer to the LPI Extra-medullary Tibial technique as described previously.

Step 3: Determination of Posterior Tibial Slope

When setting up the sagittal orientation of the proximal tibial resection, aim for a posterior slope between 0 and 3 degrees. Increasing the posterior tibial slope angle beyond 5 degrees may damage the tibial insertion of the PCL. Adjustments to the flexion gap can be made during trial reduction by using various **Logic CR Slope Tibial Insert Trial** options as detailed later in the technique.

Step 4: Determination of Tibial Resection Depth

The **Adjustable PCL Stylus** should be placed in the cutting slot of the LPI Tibial Resection Guide with the stylus in the raised position (*Figure 26a*). After assembly, snap the stylus down and place the tip of the stylus at the tibial insertion of the PCL. The Adjustable PCL stylus has three settings: 0, 2, and 4mm. This setting indicates the amount of additional distal tibial resection from the tip of the stylus. For example, if the stylus guide is set to 0mm, the tibia resection is aligned exactly to the tip of the stylus. If the stylus is set to 2mm or 4mm, the tibial resection is aligned either 2mm or 4mm below (more distal) the tip of the stylus. The recommended resection level is at the 2mm position.

Step 5: Securing Tibial Resection Guide to Tibia and Final Checking

When the proper positioning of the LPI Tibial Resection Guide has been assured, drill pins should be placed through the guide into the tibia (*Figure 26b*). Drill pins should be placed in the "0" or "nominal" holes.

The LPI Tibial Resection Guide may be adjusted proximally or distally in 2mm increments by shifting the LPI Tibial Resection guide to either the +2mm or -2mm holes on the block itself on the existing drill pins.

Proceed to make your proximal tibial resection.

PREPARATION OF THE PATELLA

For patellar resection performed without a Patellar Resection Guide ("free hand"), the patella should be stabilized with large towel clips or similar instruments. The articular surface of the patella should be resected with an oscillating saw from either (1) the edge of the medial articular surface to the edge of the lateral articular surface, or (2) from the patellar tendon insertion cephalad to the quadriceps tendon insertion (*Figure 27*). When patellar resection is complete, final determination of patellar size (diameter) and hole preparation should be performed using the **LPI Patellar Universal Drill Guide** assembled to the **LPI Patella Preparation Handle** (*Figure 28*). With the handle completely open, position the Drill Guide on the patella to determine the patellar diameter. The pattern and size of the Drill Guide holes are universal for all three-peg patella components. Clamp the patella and secure the handle by turning the knob. Holes should be drilled through the patellar universal drill guide in either the three-hole or the single-hole configuration. After the holes are drilled, loosen the knob and remove the handle and Drill Guide from the patella. The appropriate size of trial prosthesis should be placed on the patella.

Note: Other options for patella resection guides are available. See the *Patella Operative Technique Addendum* for details.

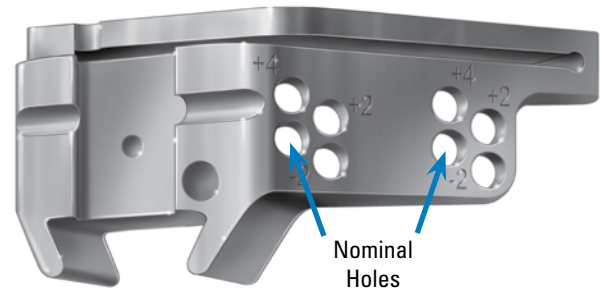

Figure 26b
Place Drill Pins

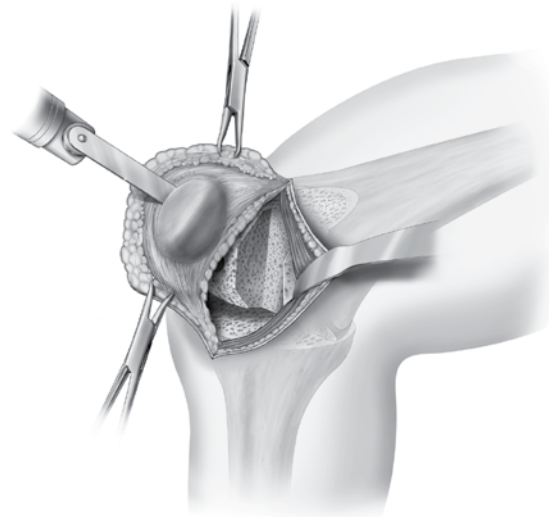

Figure 27
Prepare Patella with Freehand
Patellar Resection Technique

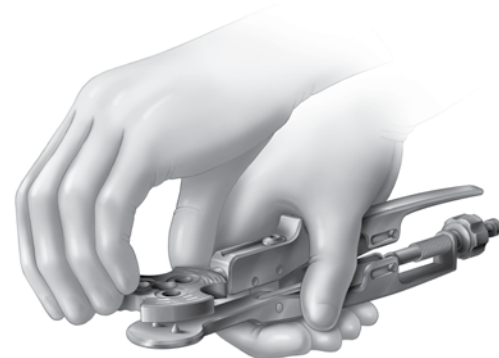

Figure 28
Assemble the LPI Universal Patellar
Drill Guide to the LPI Patella
Preparation Handle

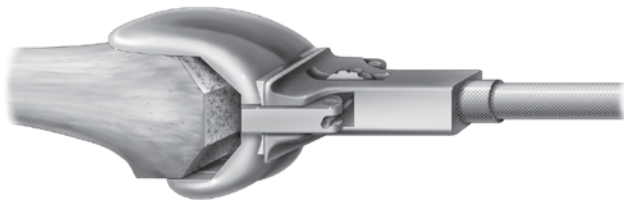

Figure 29
Place Femoral Trial

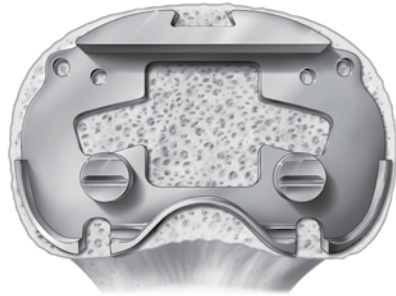

Figure 30
Fixation of Tibial Tray Trial

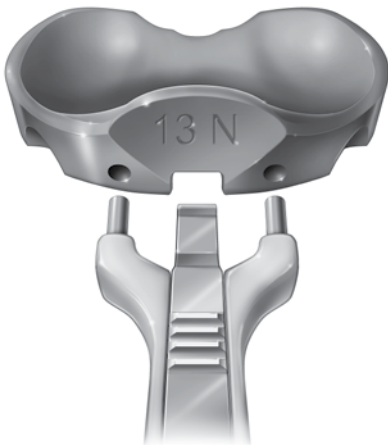

Figure 31
Assemble Trial with the Insert Handle

Figure 32
Assess Alignment



FINAL PROSTHESIS TRIAL CHECK

Final prosthesis trial check should include assessment of:

ALIGNMENT,
STABILITY,
MOTION and
PATELLAR TRACKING

Trial Placement

Place the CR Femoral Trial on the distal femur utilizing the Locking Femoral Impactor (*Figure 29*). Assemble the selected femoral trial to the Locking Femoral Impactor. Ensure that the femoral component is properly positioned on the distal femoral condyles in the medial and lateral direction. Apply slight upward pressure to the impactor handle as the component is being impacted to prevent the femoral component from rotating into flexion. Once correct positioning is assured, the component should be fully seated by striking the Locking Femoral Impactor with a mallet.

The tibial tray trial should be selected as the largest tray that fits within the borders of the resected tibial surface, without any overhang, and then fixed to the proximal tibia. Please note that the position of the tibial tray trial relative to the resected tibial surface should be centered along the A/P direction (*Figure 30*). Notably any anterior offset of the tibial tray trial should be avoided, as it would result in a posterior shift of the femoro-tibial contact point. Next, tibial insert trials should be exchanged using the LPI Trial Insert Handle until a "best fit" is achieved (*Figure 31*).

Keep in mind that the size of the femur must always match the size of the tibial insert in order to maintain the 0.96 femoral/tibial congruency.

Alignment Check

With the knee in full extension and the Mauldin Multi-Tool assembled to the Tibial Tray Trial, EM Alignment Rods should be placed in the holes in the Mauldin Multi-Tool and the alignment should be assessed (*Figure 32*). Proper rotation of the tibial component should be determined by its congruency with the femoral component. Normally, the anterior plane of the tibial component will point approximately in the direction of the tibial tubercle and second toe when congruency is established.

Stability Check

The knee should be assessed for stability in both extension and flexion. The extension check should be performed with the knee flexed a few degrees to relax the posterior capsule. However, the knee should extend fully. The flexion check should be performed with the knee flexed to 90 degrees. The most appropriate stability is achieved when the medial and lateral opening is similar to that of a normal knee during application of valgus and varus stress. An adjustment of ligament tightness between varus and valgus in flexion or extension.

PS Surgical Approach

For the PS approach, if the knee is loose in extension and flexion, proceed to exchange the Insert Trial with greater thickness and reassess stability. A Proximal Tibial Spacer (PTS) can be used for gaps requiring larger than 15mm inserts, see the PTS Annex.

Note: Optional constraint may be added by utilizing a Logic PSC insert.

CR Surgical Approach

The initial assessment should begin with the CR 9mm Neutral or Standard Tibial Insert Trial. If the joint is tight in flexion, the CR Slope 9mm + or ++ insert may be selected. There are four different indicators of a tight flexion space:

1. Excessive femoral rollback with limited ROM in flexion
2. Anterior lift-off of the Tibial Insert Trial and/or Tibial Tray Trial (*Figure 33*)
3. Palpable tension of the PCL when the knee is in flexion
4. If there is difficulty in extracting the Insert Trial with the Femoral Trial in place and the knee flexed at 90 degrees (pull-out test)

Refer to the table for tips regarding flexion/extension gap balancing (*Table 1*).

The combination of additional thicknesses and slope continues until joint stability is achieved.

Motion Check

The knee should extend fully without force (*Figure 34*). To check flexion, the surgeon should elevate the thigh and allow the leg to flex by the pull of gravity (*Figure 35*). The amount of flexion determined in this manner is the best intra-operative predictor of the flexion that will ultimately be achieved.

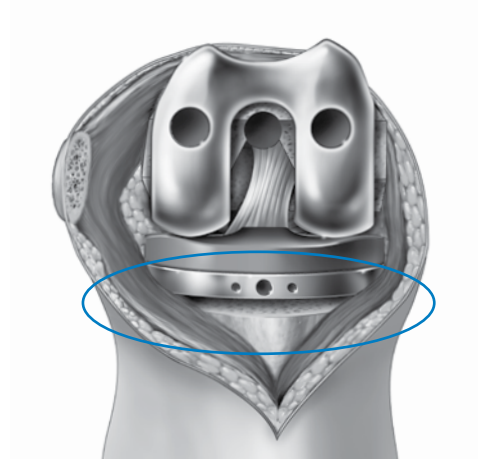

Figure 33
Anterior Lift-Off of the Tibial Tray Trial

Table 1: FLEXION/EXTENSION GAP BALANCING FOR OPTETRAK LOGIC CR

	Tight Extension	Loose Extension	OK Extension
Tight Flexion	<ul style="list-style-type: none"> • Use a thinner Logic CR Neutral Tibial Insert Trial if possible • Cut additional tibia, respecting the PCL insertion • Recess the PCL fibers respecting the PCL footprint 	<ul style="list-style-type: none"> • Increase insert thickness and trial with Logic CR Slope+ or Slope++ Tibial Insert Trials • Downsize femoral component • Recess the PCL fibers respecting the PCL footprint 	<ul style="list-style-type: none"> • Trial with Logic CR Slope+ or Slope++ Tibial Insert Trials of the same thickness • Downsize femoral component • If trialed with Slope++ and flexion gap is still tight, convert to Logic PS
Loose Flexion	<ul style="list-style-type: none"> • Resect additional distal femoral bone and use a thicker Logic CR Neutral Tibial Insert Trial • Verify integrity of the PCL if the Neutral Tibial Insert Trial is thicker than 13mm 	<ul style="list-style-type: none"> • Use a thicker Logic CR Neutral Tibial Insert Trial • Verify integrity of the PCL if the Neutral Tibial Insert Trial is thicker than 13mm 	<ul style="list-style-type: none"> • Resect additional distal femoral bone and use a thicker Logic CR Neutral Tibial Insert Trial • Verify integrity of the PCL if the Neutral Tibial Insert Trial is thicker than 13mm
OK Flexion	<ul style="list-style-type: none"> • Resect additional distal femoral bone 	<ul style="list-style-type: none"> • Increase insert thickness and trial with Logic CR Slope+ or Slope++ Tibial Insert Trials 	

Note: Some studies reported that an additional degree of insert slope on average increases peak flexion by 1.5° to 1.7°¹

Figure 34
Check Motion in Extension

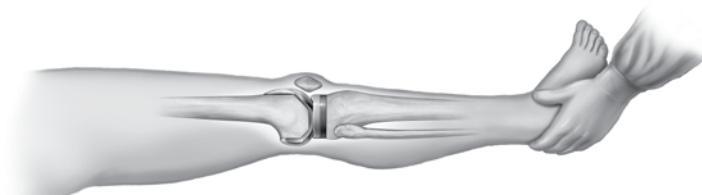

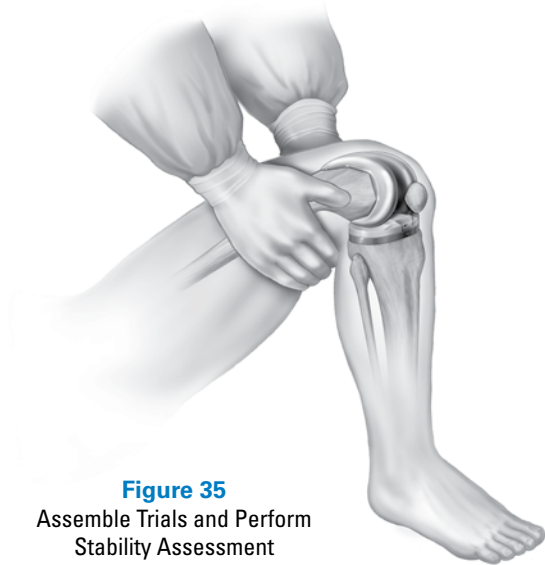

Figure 35
Assemble Trials and Perform
Stability Assessment

Patellar Tracking Check

As the knee is put through a range of motion (ROM), the patella should track smoothly in the patellar groove of the femoral prosthesis with little or no pressure exerted against its lateral edge and without it being held medially. If there is a tendency to lateral subluxation, lateral retinacular release should be performed. After final ROM assessment, remove the Optetrak LogicTibial InsertTrial and LPI Tibial TrayTrial.

For Logic CR, leave the Femoral Trial in place. The **LPI One-Peg Patellar Drill** is drilled through the medial and lateral holes on the Femoral Trial. This will create the space required to accommodate the pegs on the Logic CR femoral implant (*Figure 36*).

If the small holes created for the Femoral Finishing Guide are in the correct medial/lateral location, they may be used for the pegs of the cruciate retaining femoral prosthesis.

FINAL PREPARATION OF THE TIBIA

When all checks have been completed and the appropriate size and rotation of the tibial components have been determined, the tibia must be prepared for the tibial tray implant. Pins may be drilled or driven into the medial and lateral outrigger holes on the LPI Tibial TrayTrial to provide stability during final tibial preparation. It is recommended to use Short-Headed Pins on the inside holes or LPI Quick-Connect Headless Pins on the outrigger holes (*Figure 37*).



Figure 36
Prepare Femoral Peg Hole



Figure 37
Fixation of Tibial Tray Trial

Assemble the **Tibial Pilot Drill Guide** to the Tibial Tray Trial. Drill through the Tibial Pilot Drill Guide with the IM Pilot Drill until the mark on the IM Pilot Drill matching the selected tray size reaches the proximal surface of the Tibial Pilot Drill Guide (Figure 38).

Note: For Half sizes, drill down to the closest whole size mark.

Assemble the **LPI Fit Tibial Tamp** to the **LPI Tibial Tamp Guide** by pressing the button on the anterior distal end of the Tibial Tamp Guide and sliding the Fit Tibial Tamp into the Fit Tibial Tamp Guide (Figure 39).

Select the size on the LPI Fit Tibial Tamp corresponding to the Tibial Tray size you intend to use. The size can be selected by rotating the dial until the appropriate size is viewed in the window (Figure 39).

Align the Tamp Guide to the posterior pegs of the Tray Trial and seat the Tamp Guide flush and stable against the Tibial Tray Trial (Figure 40). The Tamp is driven into the tibia until the impaction plate contacts the handle (Figure 41).

Note: Be sure to hold the Tamp steady during impaction to avoid tilt or lift-off.

The Tamp should be ejected from the proximal tibia by squeezing the release lever (Figure 42). If the Tamp Guide does not disengage from the tibia with the release lever, a Mauldin Multi-Tool can be used to disengage it by inserting the small stud on the end of the Mauldin Multi-Tool into the hole in the handle of the Tamp, then rotating the Mauldin Multi-Tool to loosen the Tibial Tamp (Figure 43).

Figure 38
Drill Pilot Hole on Tibia

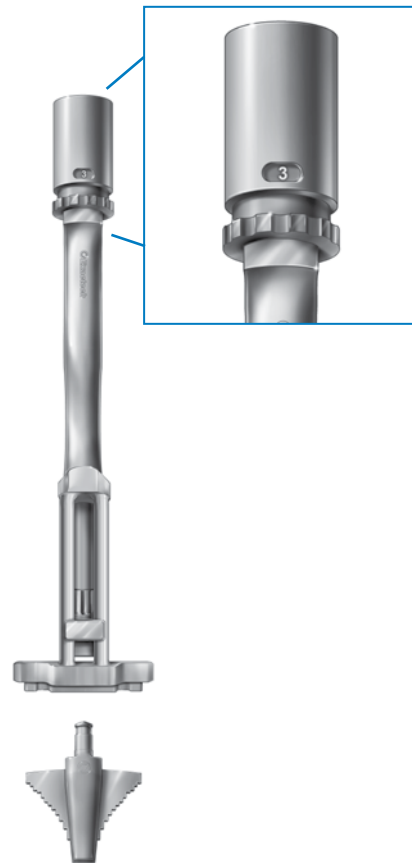
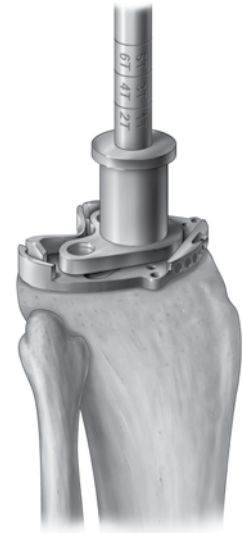

Figure 39
Assemble Tibial Tamp

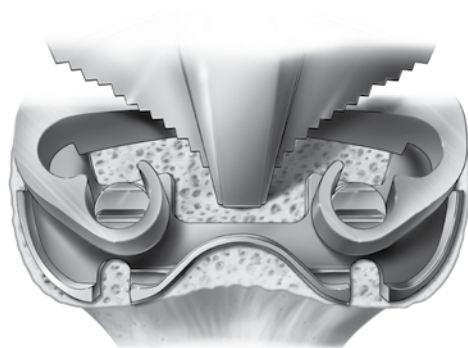

Figure 40
Align Tibial Tamp Guide



Figure 41
Fully Impact Tamp

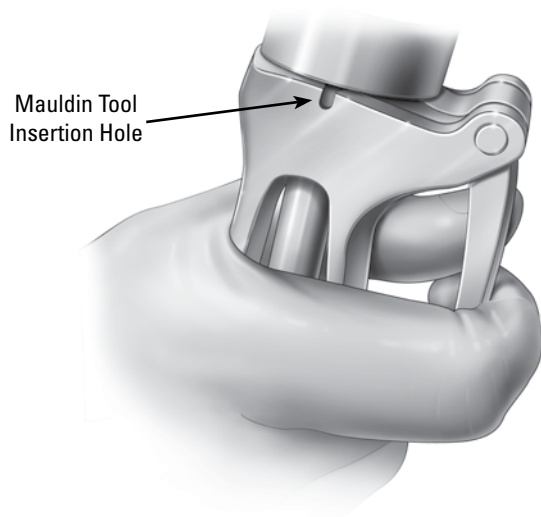

Figure 42
Eject Tibial Tamp Using the
Lever or Mauldin Tool
Insertion Hole

IMPLANTATION OF FINAL COMPONENTS

Surgeons have different preferences in regard to the sequences used to place the prosthesis components. A standard, successful technique sequence is described here. If the surgeon prefers another sequence, the Optetrak Logic knee system provides sufficient flexibility to accommodate adjustments in the implantation technique.

Step 1: Final Bone Preparation

Retractors should be placed to expose the joint (*Figure 44*). All tissue debris should be removed from resected bone surfaces. The bone trabeculae should be thoroughly cleansed with pulsed lavage.

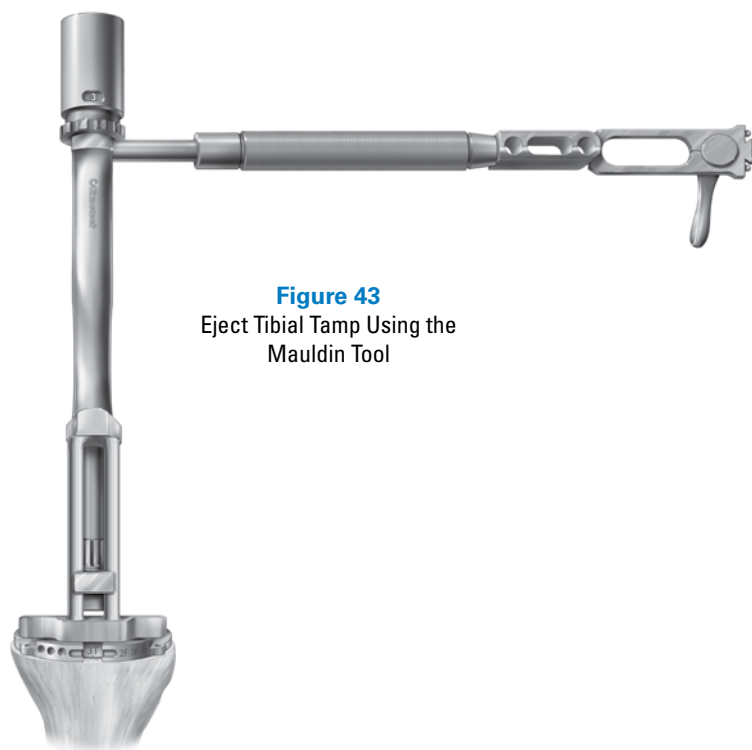

Figure 43
Eject Tibial Tamp Using the
Mauldin Tool



Figure 44
Place Retractors to
Expose the Knee Joint

Step 2: Implantation of the Tibial Prosthesis

Method 1: Implantation of Modular Tibial Component

Bone cement should be applied to the prosthesis and prepared bone surfaces when the cement has a viscosity low enough to promote good penetration into the trabecular bone.

Apply bone cement to the proximal tibia and the distal surface of the tibial tray component, including the stem, using either a cement gun or by manually pressurizing the cement. Assure that both the bone and the boneside of the prosthesis are thoroughly coated with cement. When using the Fit tray components, ensure that cement is pressed into the cement pockets (*Figures 45a-c*). Care should be taken to limit the amount of cement placed on the posterior lateral corner of the implant to limit cement cleanup in the posterior capsule.

Next, assemble the LPI impactor handle to the appropriate size Tibial Impactor Plate (*Figures 46*).

Introduce the tibial tray component onto the prepared tibial surface using the **Locking Tibial Tray Impactor** construct by applying a constant downward force (*Figure 47*).

The extraneous cement must be removed from the borders of the tibial component, starting posteriorly and working around to the sides and front. All cement must be removed from the posterior capsular area of the knee.



Figure 45a
Press Cement Into Cement Pockets



Figure 45b
Coat Tray Thoroughly with Cement

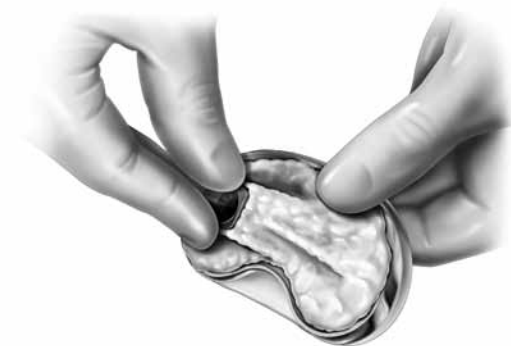

Figure 45c
Coat Keel Thoroughly with Cement



Figure 46
Assemble Locking Tibial Tray Impactor
and Impact Tibial Component



Figure 47
Place Tibial Prosthesis

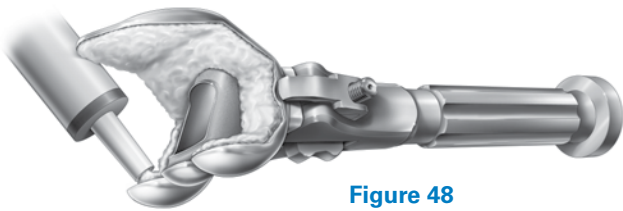

Figure 48
Place Cement on
Femoral Component

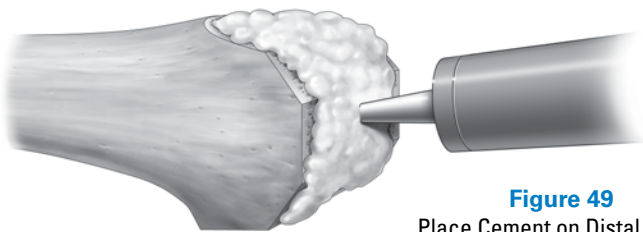

Figure 49
Place Cement on Distal Femur



Figure 50
Position Femoral Component
on Distal Femur

Method 2: Implantation of Pre-assembled Tibial Components

Alternately, the polyethylene tibial insert may be assembled to the tibial tray prior to implantation. In this case, the **Tibial Insert Driver** should be used to complete the installation of the pre-assembled tibial components. At this point, bone cement should be applied to the prosthesis and prepared bone surfaces as described in Method 1.

Introduce the pre-assembled tibial components onto the prepared tibial surface using the **LPI Non-Locking Tibial Impactor**, applying a constant downward force.

All extraneous cement must be removed from the borders of the tibial component, starting posteriorly and working around to the sides and front. All cement must be removed from the posterior capsular area of the knee. The same technique applies when using all-polyethylene or metal-backed tibial components.

Step 3: Implantation of Femoral Component

With the femoral component assembled to the **LPI Locking Femoral Impactor**, apply bone cement to the bone mating surface of the femoral component (*Figure 48*). Take care to apply only a thin layer of cement on the posterior surface of the prosthesis in order to avoid excessive cement extrusion posteriorly where it could be difficult to remove.

Apply bone cement to the anterior, chamfer and distal surfaces of the prepared femur (*Figure 49*). Avoid placing cement on the posterior bone surface to prevent excessive cement extrusion posteriorly. Using the LPI Locking Femoral Impactor, position the femoral component onto the distal femur (*Figure 50*). Slight upward pressure should be applied to the Impactor Handle as the component is being impacted to prevent the femoral component from rotating into flexion.

To assemble the **Non-locking Femoral Impactor** to the **LPI Impactor Handle**, place the lever on the LPI Impactor Handle to the “release” position, attach the Non-locking Femoral Impactor onto the handle then move the lever to the “locked” position (*Figure 51*). Final impaction of the femoral component is performed with the Non-locking Femoral Impactor assembled to the LPI Impactor Handle (*Figure 52*).

Care should be taken to remove all excess bone cement.

Step 4: Implantation of Patellar Component

Coat the resected patella surface and bone-mating surface of the patellar component with cement. Align the pegs of the patellar implant with the previously drilled peg hole(s) in the patella bone and press the implant onto the patella.

Assemble the **LPI Patella Clamp Head** to the **LPI Patellar Preparation Handle** (*Figure 53*). Clamp the patellar component onto the patella bone with the LPI Patella Preparation Handle and Clamp Head, avoiding excessive clamping pressure as it may damage the patella, especially when the bone is soft. Lock the handle by adjusting the locking nut.

Step 5: Polymerization of Cement

A Tibial Insert Trial should be used when pressurizing the cement during polymerization. Hold axial pressure across the joint during cement polymerization, avoiding either hyperextension or flexion which may tip the prosthesis into either flexion or extension (*Figure 54*).

This is important in every case, but especially in osteopenic bone. Avoid any movement of the prosthesis until the bone cement has completely polymerized.

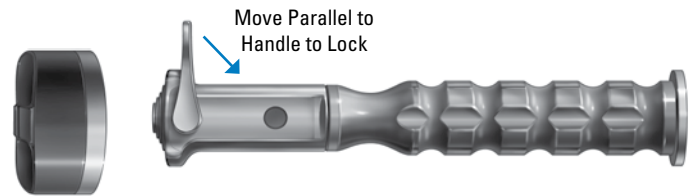

Figure 51
Assemble Non-Locking
Femoral Impactor to the
LPI Impactor Handle

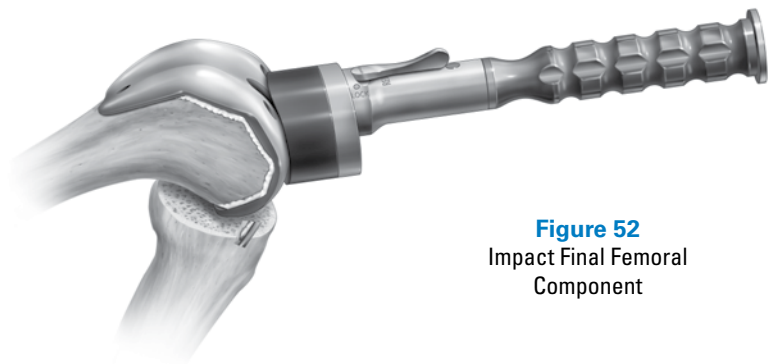

Figure 52
Impact Final Femoral
Component



Figure 53
Assemble LPI Patellar Clamp

Figure 54
Axial Pressure During Cement
Polymerization

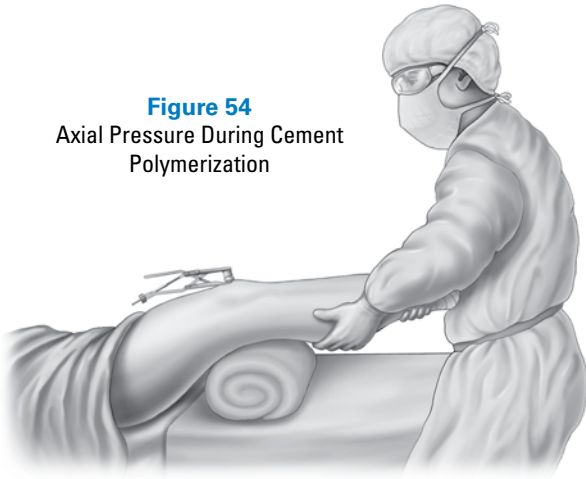

Figure 55
Introduce Polyethylene Insert



Figure 56
Assemble Polyethylene
Insert to Tibial Tray



**Step 6: Installation of Tibial Polyethylene Insert
(Modular Tibial Component Only)**

After polymerization of the cement, introduce the polyethylene insert into the previously implanted tibial tray taking care that the posterior feet of the insert appropriately engage the undercuts of the posterior aspect of the metal tibial tray (*Figure 55*).

Be sure to check for any soft tissue or bony remnants that could interfere with implant assembly. Continue pushing the polyethylene insert back with two thumbs until the insert is fully engaged and the anterior gap between the tray and the insert is closed (*Figure 56*).

The **Tibial Insert Driver** should be used to complete the assembly of the tibial components (*Figure 57*). A mallet should be used for final impaction of the tibial component.

The surgeon should check to be certain that the tibial insert is fully seated in the metal tibial tray.

FINAL CHECK AND CLOSURE

Final check includes the following:

1. Removal of any remaining extruded cement
2. Final assessment of:

ALIGNMENT,
STABILITY,
MOTION and
PATELLAR TRACKING

Closure:

A standard closure technique preferred by the surgeon may be used.

Figure 57
Complete Tibial
Component Assembly
Using Tibial Insert Driver

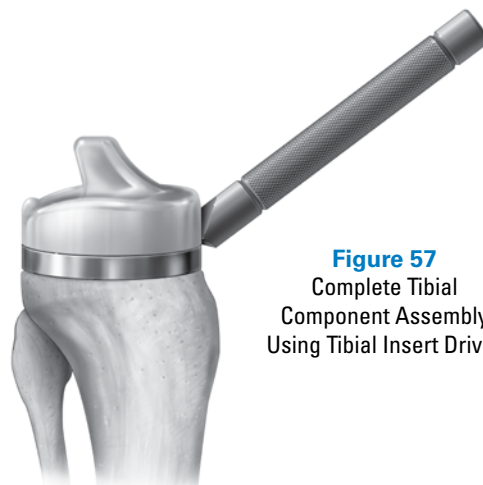

PTS ANNEX

For gaps that require greater than 15mm tibial inserts

INTRODUCTION

Optetrak Logic Proximal Tibial Spacer (PTS) is a titanium spacer intended to provide surgeons more flexibility in the adjustment of flexion and extension gaps. PTS maintains the three-part locking features found on all Optetrak Logic modular tibial trays, including posterior undercuts, a central “mushroom” and a peripheral rim (Figure 58). This allows Optetrak Logic tibial inserts to lock into PTS exactly the same way they would lock into an Optetrak modular tibial tray.

DESIGN SPECIFICATIONS

Optetrak Logic PTS is compatible with all Optetrak Logic modular tibial trays and tibial inserts that are 9 to 15mm thick, allowing surgeons to accommodate flexion and extension gaps ranging from 17 to 23mm. The femur, tibia and patella should be prepared as described previously in the Logic LPI Operative Technique.



Figure 58
Cross-section of Proximal Tibial Spacer

Step 1: Perform a trial reduction and assess stability of the joint both in flexion and extension (Figure 59). If the flexion and extension gaps are loose during trial reduction with a 15mm tibial insert trial, PTS can be combined with the 9, 11, 13 or 15mm tibial insert trial for 17mm to 23mm gaps (Table 1). Select the PTS trial that corresponds with the Optetrak Logic tibial insert trial size being used. For example, if a Size 3 tibial insert trial is being used, an 8mm Optetrak PTS Trial, Size 3 must be selected.

Step 2: Place the PTS trial onto the Optetrak Logic tibial tray trial. Place the Optetrak Logic tibial insert trial onto the Optetrak Logic PTS trial (Figure 60). Proceed with the trial reduction to assess stability. If the flexion and extension gaps are loose, select the next thickness insert trial and re-assess. Once the flexion and extension gaps have been properly balanced after the trial reduction, proceed to the final preparation of the tibia.

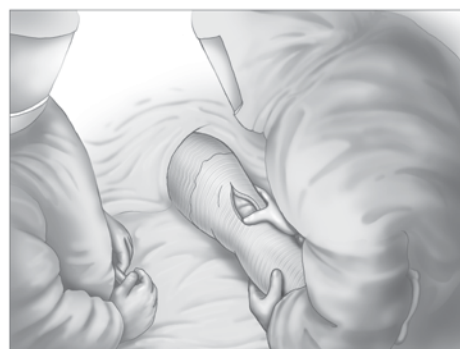

Figure 59
Assessment of Overall Stability of Knee Joint in Flexion and Extension

Table 1: OVERALL THICKNESS OF OPTETRAK LOGIC INSERT TRIALS AND PTS

Trial Insert Thickness	PTS Thickness	Overall Insert Thickness
9mm	8mm	17mm
11mm	8mm	19mm
13mm	8mm	21mm
15mm	8mm	23mm

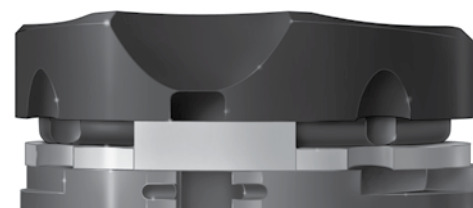

Figure 60
PTS Trial Assembled to Modular Insert Trial



Figure 61
PTS and Tibial Tray
Assembly Impaction

Step 3: Assemble PTS onto the appropriate Optetrak Logic tibial tray. The assembly should be performed on the back table of the operating room. Engage the posterior feet of PTS with the posterior undercut of the Optetrak Logic tibial tray. Protect the anterior of the PTS with a lap or sponge and tap with a mallet. Place the PTS and Optetrak Logic tibial tray assembly upside-down on a flat surface. Protect the bottom surface of the tibial tray with a sponge or lap. Impact the Optetrak tibial tray until PTS is fully seated onto the tray (*Figure 61*).

Step 4: Insert the **Optetrak Logic PTS Locking Screw** through the central hole of PTS. The screw will keep the mushroom feature on PTS engaged with the Optetrak Logic tibial tray. Using the **Optetrak Logic PTS Locking Hex Screwdriver**, tighten the screw (*Figure 62*). The PTS Locking Hex Screwdriver should be rotated until the screw is fully seated, or flush with the mushroom hole in PTS (*Figure 63*).

Caution: Do not over-tighten the PTS Locking Screw. Over-tightening the locking screw will cause the hex feature on both components to deform, making it difficult to extract the PTS Locking Hex Screwdriver from the PTS Locking Screw.

Proceed to the implantation of final components and final check and closure. Recommended cementation techniques should be followed as described in the corresponding Optetrak Logic operative techniques.



Figure 62
Insert PTS Locking Screw with PTS Locking
Hex Screwdriver

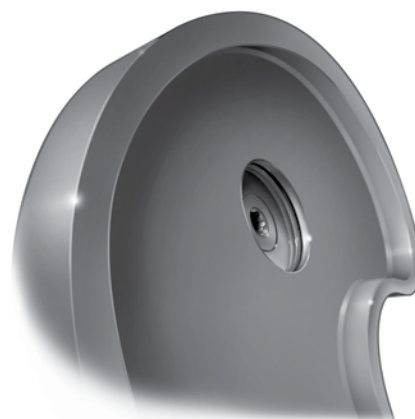

Figure 63
PTS Locking Screw Fully Seated

INSTRUMENT LISTING

Catalog Number Part Description

201-02-26 Three-Peg Patella Trial, Size 26
 201-02-29 Three-Peg Patella Trial, Size 29
 201-02-32 Three-Peg Patella Trial, Size 32
 201-02-35 Three-Peg Patella Trial, Size 35
 201-02-38 Three-Peg Patella Trial, Size 38
 201-02-41 Three-Peg Patella Trial, Size 41



201-40-03 IM Pilot Drill



201-41-00 T-Handle Intra-medullary Rod



201-44-00 Mauldin Multi-Tool



201-58-01 Extra-medullary Tibial Alignment Rod/Coupler



201-58-02 Extra-medullary Alignment Rod



201-61-11 Patellar Drill, One-Peg, Zimmer Hudson



201-61-13 Patellar Drill, Three-Peg, Zimmer Hudson



201-78-11 Holding Pin, Small Head, Cup Point, 1.75"



201-78-51 Quick Chuck w/Hall End, 1/8"



201-78-89 Quick Connect Drill Bit modified Hex, 3", 1/8"



201-90-01 Tibial Insert Driver



213-03-02* LPI Intra-medullary Alignment Guide Bushing,
 2 Degrees, 8mm*
 213-03-05 LPI Intra-medullary Alignment Guide Bushing,
 5 Degrees, 8mm
 213-03-06 LPI Intra-medullary Alignment Guide Bushing,
 6 Degrees, 8mm
 213-03-07 LPI Intra-medullary Alignment Guide Bushing,
 7 Degrees, 8mm

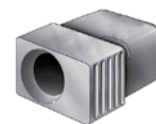

Catalog Number Part Description

213-37-02 LPI Femoral A/P Sizer

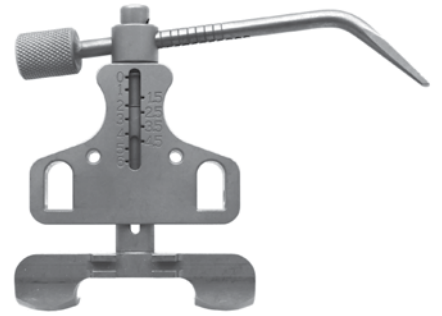

213-44-01 LPI Offset A/P Sizer Handle



213-46-12 LPI Pin Puller



213-56-00 LPI 0-Degree Femoral A/P Sizer Drill Guide
 213-56-01 LPI 3-Degree Femoral A/P Sizer Drill Guide, Right
 213-56-02 LPI 3-Degree Femoral A/P Sizer Drill Guide, Left



213-49-00 LPI A/P Sizer Collar Drill, 4mm



213-50-10* LPI Femoral Finishing Guide, Size 0
 213-50-11 LPI Femoral Finishing Guide, Size 1
 213-50-51* LPI Femoral Finishing Guide, Size 1.5
 213-50-12 LPI Femoral Finishing Guide, Size 2
 213-50-52 LPI Femoral Finishing Guide, Size 2.5
 213-50-13 LPI Femoral Finishing Guide, Size 3
 213-50-53 LPI Femoral Finishing Guide, Size 3.5
 213-50-14 LPI Femoral Finishing Guide, Size 4
 213-50-15 LPI Femoral Finishing Guide, Size 5
 213-50-16* LPI Femoral Finishing Guide, Size 6



213-52-10 LPI Finishing Guide Impaction/Extraction Handle



213-64-01 LPI Locking Femoral Impactor



213-72-00 Fit Tray Tibial Pilot Drill



INSTRUMENT LISTING

Catalog Number Part Description

213-83-00 LPI Distal Femoral Resection Guide



213-83-10 LPI Distal Link



213-60-00 LPI Patella Prep Handle



213-60-01 LPI Patella Clamp Head



213-60-08 LPI Patellar Universal Drill Guide



213-65-00 LPI Impactor Handle



213-65-01 LPI Tibial Tray Impact Plate, Sizes 0-2
 213-65-02 LPI Tibial Tray Impact Plate, Sizes 3,4
 213-65-03 LPI Tibial Tray Impact Plate, Sizes 4,5



213-65-04 LPI Femoral Impactor, Non-locking



213-65-05 LPI Tibial Insert Impactor Head



213-66-03 Logic PS Femoral Trial Extractor



Catalog Number Part Description

213-66-04 Logic CR Femoral Trial Extractor



213-67-00 Patella Thickness Gauge



213-73-17 LPI Tibial Resection Guide, Left
213-73-18 LPI Tibial Resection Guide, Right



213-75-00 LPI Fit Tibial Tamp Guide



213-75-01 LPI Fit Tibial Tamp Head



213-77-01 LPI Cut Line Predictor



231-04-01 No-Touch PCL Retractor



231-04-02 Adjustable PCL Stylus



231-04-03 LPI Trial Insert Handle



INSTRUMENT LISTING

Catalog Number Part Description

02-011-01-0200*	Logic Femoral Trial, PS, Size 0, Left
02-011-01-0300*	Logic Femoral Trial, PS, Size 0, Right
02-011-01-0210	Logic Femoral Trial, PS, Size 1, Left
02-011-01-0310	Logic Femoral Trial, PS, Size 1, Right
02-011-01-0215*	Logic Femoral Trial, PS, Size 1.5, Left
02-011-01-0315*	Logic Femoral Trial, PS, Size 1.5, Right
02-011-01-0220	Logic Femoral Trial, PS, Size 2, Left
02-011-01-0320	Logic Femoral Trial, PS, Size 2, Right
02-011-01-0225	Logic Femoral Trial, PS, Size 2.5, Left
02-011-01-0325	Logic Femoral Trial, PS, Size 2.5, Right
02-011-01-0230	Logic Femoral Trial, PS, Size 3, Left
02-011-01-0330	Logic Femoral Trial, PS, Size 3, Right
02-011-01-0235	Logic Femoral Trial, PS, Size 3.5, Left
02-011-01-0335	Logic Femoral Trial, PS, Size 3.5, Right
02-011-01-0240	Logic Femoral Trial, PS, Size 4, Left
02-011-01-0340	Logic Femoral Trial, PS, Size 4, Right
02-011-01-0250	Logic Femoral Trial, PS, Size 5, Left
02-011-01-0350	Logic Femoral Trial, PS, Size 5, Right
02-011-01-0260*	Logic Femoral Trial, PS, Size 6, Left
02-011-01-0360*	Logic Femoral Trial, PS, Size 6, Right



02-011-03-0200*	Logic Femoral Trial, CR, Size 0, Left
02-011-03-0300*	Logic Femoral Trial, CR, Size 0, Right
02-011-03-0210	Logic Femoral Trial, CR, Size 1, Left
02-011-03-0310	Logic Femoral Trial, CR, Size 1, Right
02-011-03-0215*	Logic Femoral Trial, CR, Size 1.5, Left
02-011-03-0315*	Logic Femoral Trial, CR, Size 1.5, Right
02-011-03-0220	Logic Femoral Trial, CR, Size 2, Left
02-011-03-0320	Logic Femoral Trial, CR, Size 2, Right
02-011-03-0225	Logic Femoral Trial, CR, Size 2.5, Left
02-011-03-0325	Logic Femoral Trial, CR, Size 2.5, Right
02-011-03-0230	Logic Femoral Trial, CR, Size 3, Left
02-011-03-0330	Logic Femoral Trial, CR, Size 3, Right
02-011-03-0235	Logic Femoral Trial, CR, Size 3.5, Left
02-011-03-0335	Logic Femoral Trial, CR, Size 3.5, Right
02-011-03-0240	Logic Femoral Trial, CR, Size 4, Left
02-011-03-0340	Logic Femoral Trial, CR, Size 4, Right
02-011-03-0250	Logic Femoral Trial, CR, Size 5, Left
02-011-03-0350	Logic Femoral Trial, CR, Size 5, Right
02-011-03-0260*	Logic Femoral Trial, CR, Size 6, Left
02-011-03-0360*	Logic Femoral Trial, CR, Size 6, Right



Catalog Number Part Description

02-013-35-0009*	Logic Tibial Insert Trial, PS, Size 0, 9mm
02-013-35-0011*	Logic Tibial Insert Trial, PS, Size 0, 11mm
02-013-35-0013*	Logic Tibial Insert Trial, PS, Size 0, 13mm
02-013-35-0015*	Logic Tibial Insert Trial, PS, Size 0, 15mm
02-013-35-1009	Logic Tibial Insert Trial, PS, Size 1, 9mm
02-013-35-1011	Logic Tibial Insert Trial, PS, Size 1, 11mm
02-013-35-1013	Logic Tibial Insert Trial, PS, Size 1, 13mm
02-013-35-1015	Logic Tibial Insert Trial, PS, Size 1, 15mm
02-013-35-1509*	Logic Tibial Insert Trial, PS, Size 1.5, 9mm
02-013-35-1511*	Logic Tibial Insert Trial, PS, Size 1.5, 11mm
02-013-35-1513*	Logic Tibial Insert Trial, PS, Size 1.5, 13mm
02-013-35-1515*	Logic Tibial Insert Trial, PS, Size 1.5, 15mm
02-013-35-2009	Logic Tibial Insert Trial, PS, Size 2, 9mm
02-013-35-2011	Logic Tibial Insert Trial, PS, Size 2, 11mm
02-013-35-2013	Logic Tibial Insert Trial, PS, Size 2, 13mm
02-013-35-2015	Logic Tibial Insert Trial, PS, Size 2, 15mm
02-013-35-2509	Logic Tibial Insert Trial, PS, Size 2.5, 9mm
02-013-35-2511	Logic Tibial Insert Trial, PS, Size 2.5, 11mm
02-013-35-2513	Logic Tibial Insert Trial, PS, Size 2.5, 13mm
02-013-35-2515	Logic Tibial Insert Trial, PS, Size 2.5, 15mm
02-013-35-3009	Logic Tibial Insert Trial, PS, Size 3, 9mm
02-013-35-3011	Logic Tibial Insert Trial, PS, Size 3, 11mm
02-013-35-3013	Logic Tibial Insert Trial, PS, Size 3, 13mm
02-013-35-3015	Logic Tibial Insert Trial, PS, Size 3, 15mm
02-013-35-3509	Logic Tibial Insert Trial, PS, Size 3.5, 9mm
02-013-35-3511	Logic Tibial Insert Trial, PS, Size 3.5, 11mm
02-013-35-3513	Logic Tibial Insert Trial, PS, Size 3.5, 13mm
02-013-35-3515	Logic Tibial Insert Trial, PS, Size 3.5, 15mm
02-013-35-4009	Logic Tibial Insert Trial, PS, Size 4, 9mm
02-013-35-4011	Logic Tibial Insert Trial, PS, Size 4, 11mm
02-013-35-4013	Logic Tibial Insert Trial, PS, Size 4, 13mm
02-013-35-4015	Logic Tibial Insert Trial, PS, Size 4, 15mm
02-013-35-5009	Logic Tibial Insert Trial, PS, Size 5, 9mm
02-013-35-5011	Logic Tibial Insert Trial, PS, Size 5, 11mm
02-013-35-5013	Logic Tibial Insert Trial, PS, Size 5, 13mm
02-013-35-5015	Logic Tibial Insert Trial, PS, Size 5, 15mm
02-013-35-6011*	Logic Tibial Insert Trial, PS, Size 6, 11mm
02-013-35-6013*	Logic Tibial Insert Trial, PS, Size 6, 13mm
02-013-35-6015*	Logic Tibial Insert Trial, PS, Size 6, 15mm



INSTRUMENT LISTING

Catalog Number	Part Description
02-013-44-0009*	Logic Tibial Insert Trial, PSC, SIZE 0, 9mm
02-013-44-0011*	Logic Tibial Insert Trial, PSC, SIZE 0, 11mm
02-013-44-0013*	Logic Tibial Insert Trial, PSC, SIZE 0, 13mm
02-013-44-0015*	Logic Tibial Insert Trial, PSC, SIZE 0, 15mm
02-013-44-1009	Logic Tibial Insert Trial, PSC, SIZE 1, 9mm
02-013-44-1011	Logic Tibial Insert Trial, PSC, SIZE 1, 11mm
02-013-44-1013	Logic Tibial Insert Trial, PSC, SIZE 1, 13mm
02-013-44-1015	Logic Tibial Insert Trial, PSC, SIZE 1, 15mm
02-013-44-1509*	Logic Tibial Insert Trial, PSC, SIZE 1.5, 9mm
02-013-44-1511*	Logic Tibial Insert Trial, PSC, SIZE 1.5, 11mm
02-013-44-1513*	Logic Tibial Insert Trial, PSC, SIZE 1.5, 13mm
02-013-44-1515*	Logic Tibial Insert Trial, PSC, SIZE 1.5, 15mm
02-013-44-2009	Logic Tibial Insert Trial, PSC, SIZE 2, 9mm
02-013-44-2011	Logic Tibial Insert Trial, PSC, SIZE 2, 11mm
02-013-44-2013	Logic Tibial Insert Trial, PSC, SIZE 2, 13mm
02-013-44-2015	Logic Tibial Insert Trial, PSC, SIZE 2, 15mm
02-013-44-2509	Logic Tibial Insert Trial, PSC, SIZE 2.5, 9mm
02-013-44-2511	Logic Tibial Insert Trial, PSC, SIZE 2.5, 11mm
02-013-44-2513	Logic Tibial Insert Trial, PSC, SIZE 2.5, 13mm
02-013-44-2515	Logic Tibial Insert Trial, PSC, SIZE 2.5, 15mm
02-013-44-3009	Logic Tibial Insert Trial, PSC, SIZE 3, 9mm
02-013-44-3011	Logic Tibial Insert Trial, PSC, SIZE 3, 11mm
02-013-44-3013	Logic Tibial Insert Trial, PSC, SIZE 3, 13mm
02-013-44-3015	Logic Tibial Insert Trial, PSC, SIZE 3, 15mm
02-013-44-3509	Logic Tibial Insert Trial, PSC, SIZE 3.5, 9mm
02-013-44-3511	Logic Tibial Insert Trial, PSC, SIZE 3.5, 11mm
02-013-44-3513	Logic Tibial Insert Trial, PSC, SIZE 3.5, 13mm
02-013-44-3515	Logic Tibial Insert Trial, PSC, SIZE 3.5, 15mm
02-013-44-4009	Logic Tibial Insert Trial, PSC, SIZE 4, 9mm
02-013-44-4011	Logic Tibial Insert Trial, PSC, SIZE 4, 11mm
02-013-44-4013	Logic Tibial Insert Trial, PSC, SIZE 4, 13mm
02-013-44-4015	Logic Tibial Insert Trial, PSC, SIZE 4, 15mm
02-013-44-5009	Logic Tibial Insert Trial, PSC, SIZE 5, 9mm
02-013-44-5011	Logic Tibial Insert Trial, PSC, SIZE 5, 11mm
02-013-44-5013	Logic Tibial Insert Trial, PSC, SIZE 5, 13mm
02-013-44-5015	Logic Tibial Insert Trial, PSC, SIZE 5, 15mm
02-013-44-6011*	Logic Tibial Insert Trial, PSC, SIZE 6, 11mm
02-013-44-6013*	Logic Tibial Insert Trial, PSC, SIZE 6, 13mm
02-013-44-6015*	Logic Tibial Insert Trial, PSC, SIZE 6, 15mm



Catalog Number Part Description

02-013-47-0009*	Logic Tibial Insert Trial, CR Neutral, Size 0, 9mm
02-013-47-0011*	Logic Tibial Insert Trial, CR Neutral, Size 0, 11mm
02-013-47-0013*	Logic Tibial Insert Trial, CR Neutral, Size 0, 13 mm
02-013-47-0015*	Logic Tibial Insert Trial, CR Neutral, Size 0, 15 mm
02-013-47-1009	Logic Tibial Insert Trial, CR Neutral, Size 1, 9mm
02-013-47-1011	Logic Tibial Insert Trial, CR Neutral, Size 1, 11mm
02-013-47-1013	Logic Tibial Insert Trial, CR Neutral, Size 1, 13mm
02-013-47-1015	Logic Tibial Insert Trial, CR Neutral, Size 1, 15mm
02-013-57-1509*	Logic Tibial Insert Trial, CR Neutral, Size 1.5, 9mm
02-013-57-1511*	Logic Tibial Insert Trial, CR Neutral, Size 1.5, 11mm
02-013-57-1513*	Logic Tibial Insert Trial, CR Neutral, Size 1.5, 13mm
02-013-57-1515*	Logic Tibial Insert Trial, CR Neutral, Size 1.5, 15mm
02-013-47-2009	Logic Tibial Insert Trial, CR Neutral, Size 2, 9mm
02-013-47-2011	Logic Tibial Insert Trial, CR Neutral, Size 2, 11mm
02-013-47-2013	Logic Tibial Insert Trial, CR Neutral, Size 2, 13mm
02-013-47-2015	Logic Tibial Insert Trial, CR Neutral, Size 2, 15mm
02-013-57-2509	Logic Tibial Insert Trial, CR Neutral, Size 2.5, 9mm
02-013-57-2511	Logic Tibial Insert Trial, CR Neutral, Size 2.5, 11mm
02-013-57-2513	Logic Tibial Insert Trial, CR Neutral, Size 2.5, 13mm
02-013-57-2515	Logic Tibial Insert Trial, CR Neutral, Size 2.5, 15mm
02-013-47-3009	Logic Tibial Insert Trial, CR Neutral, Size 3, 9mm
02-013-47-3011	Logic Tibial Insert Trial, CR Neutral, Size 3, 11mm
02-013-47-3013	Logic Tibial Insert Trial, CR Neutral, Size 3, 13mm
02-013-47-3015	Logic Tibial Insert Trial, CR Neutral, Size 3, 15mm
02-013-57-3509	Logic Tibial Insert Trial, CR Neutral, Size 3.5, 9mm
02-013-57-3511	Logic Tibial Insert Trial, CR Neutral, Size 3.5, 11mm
02-013-57-3513	Logic Tibial Insert Trial, CR Neutral, Size 3.5, 13mm
02-013-57-3515	Logic Tibial Insert Trial, CR Neutral, Size 3.5, 15mm
02-013-47-4009	Logic Tibial Insert Trial, CR Neutral, Size 4, 9mm
02-013-47-4011	Logic Tibial Insert Trial, CR Neutral, Size 4, 11mm
02-013-47-4013	Logic Tibial Insert Trial, CR Neutral, Size 4, 13mm
02-013-47-4015	Logic Tibial Insert Trial, CR Neutral, Size 4, 15mm
02-013-47-5009	Logic Tibial Insert Trial, CR Neutral, Size 5, 9mm
02-013-47-5011	Logic Tibial Insert Trial, CR Neutral, Size 5, 11mm
02-013-47-5013	Logic Tibial Insert Trial, CR Neutral, Size 5, 13mm
02-013-47-5015	Logic Tibial Insert Trial, CR Neutral, Size 5, 15mm
02-013-47-6011*	Logic Tibial Insert Trial, CR Neutral, Size 6, 11mm
02-013-47-6013*	Logic Tibial Insert Trial, CR Neutral, Size 6, 13mm
02-013-47-6015*	Logic Tibial Insert Trial, CR Neutral, Size 6, 15mm



INSTRUMENT LISTING

Catalog Number Part Description

02-013-48-0009*	Logic Tibial Insert Trial, CR Slope+, Size 0, 9mm
02-013-48-0011*	Logic Tibial Insert Trial, CR Slope+, Size 0, 11mm
02-013-48-0013*	Logic Tibial Insert Trial, CR Slope+, Size 0, 13mm
02-013-48-1009	Logic Tibial Insert Trial, CR Slope+, Size 1, 9mm
02-013-48-1011	Logic Tibial Insert Trial, CR Slope+, Size 1, 11mm
02-013-48-1013	Logic Tibial Insert Trial, CR Slope+, Size 1, 13mm
02-013-58-1509*	Logic Tibial Insert Trial, CR Slope+, Size 1.5, 9mm
02-013-58-1511*	Logic Tibial Insert Trial, CR Slope+, Size 1.5, 11mm
02-013-58-1513*	Logic Tibial Insert Trial, CR Slope+, Size 1.5, 13mm
02-013-48-2009	Logic Tibial Insert Trial, CR Slope+, Size 2, 9mm
02-013-48-2011	Logic Tibial Insert Trial, CR Slope+, Size 2, 11mm
02-013-48-2013	Logic Tibial Insert Trial, CR Slope+, Size 2, 13mm
02-013-48-2509	Logic Tibial Insert Trial, CR Slope+, Size 2.5, 9mm
02-013-48-2511	Logic Tibial Insert Trial, CR Slope+, Size 2.5, 11mm
02-013-48-2513	Logic Tibial Insert Trial, CR Slope+, Size 2.5, 13mm
02-013-58-3009	Logic Tibial Insert Trial, CR Slope+, Size 3, 9mm
02-013-58-3011	Logic Tibial Insert Trial, CR Slope+, Size 3, 11mm
02-013-58-3013	Logic Tibial Insert Trial, CR Slope+, Size 3, 13mm
02-013-48-3509	Logic Tibial Insert Trial, CR Slope+, Size 3.5, 9mm
02-013-48-3511	Logic Tibial Insert Trial, CR Slope+, Size 3.5, 11mm
02-013-48-3513	Logic Tibial Insert Trial, CR Slope+, Size 3.5, 13mm
02-013-58-4009	Logic Tibial Insert Trial, CR Slope+, Size 4, 9mm
02-013-58-4011	Logic Tibial Insert Trial, CR Slope+, Size 4, 11mm
02-013-58-4013	Logic Tibial Insert Trial, CR Slope+, Size 4, 13mm
02-013-48-5009	Logic Tibial Insert Trial, CR Slope+, Size 5, 9mm
02-013-48-5011	Logic Tibial Insert Trial, CR Slope+, Size 5, 11mm
02-013-48-5013	Logic Tibial Insert Trial, CR Slope+, Size 5, 13mm
02-013-48-6011*	Logic Tibial Insert Trial, CR Slope+, Size 6, 11mm
02-013-48-6013*	Logic Tibial Insert Trial, CR Slope+, Size 6, 13mm
02-013-49-0009*	Logic Tibial Insert Trial, CR Slope++, Size 0, 9mm
02-013-49-0011*	Logic Tibial Insert Trial, CR Slope++, Size 0, 11mm
02-013-49-0013*	Logic Tibial Insert Trial, CR Slope++, Size 0, 13mm
02-013-49-1009	Logic Tibial Insert Trial, CR Slope++, Size 1, 9mm
02-013-49-1011	Logic Tibial Insert Trial, CR Slope++, Size 1, 11mm
02-013-49-1013	Logic Tibial Insert Trial, CR Slope++, Size 1, 13mm
02-013-59-1509*	Logic Tibial Insert Trial, CR Slope++, Size 1.5, 9mm
02-013-59-1511*	Logic Tibial Insert Trial, CR Slope++, Size 1.5, 11mm
02-013-59-1513*	Logic Tibial Insert Trial, CR Slope++, Size 1.5, 13mm
02-013-49-2009	Logic Tibial Insert Trial, CR Slope++, Size 2, 9mm
02-013-49-2011	Logic Tibial Insert Trial, CR Slope++, Size 2, 11mm
02-013-49-2013	Logic Tibial Insert Trial, CR Slope++, Size 2, 13mm
02-013-59-2509	Logic Tibial Insert Trial, CR Slope++, Size 2.5, 9mm
02-013-59-2511	Logic Tibial Insert Trial, CR Slope++, Size 2.5, 11mm
02-013-59-2513	Logic Tibial Insert Trial, CR Slope++, Size 2.5, 13mm
02-013-49-3009	Logic Tibial Insert Trial, CR Slope++, Size 3, 9mm
02-013-49-3011	Logic Tibial Insert Trial, CR Slope++, Size 3, 11mm
02-013-49-3013	Logic Tibial Insert Trial, CR Slope++, Size 3, 13mm
02-013-49-3509	Logic Tibial Insert Trial, CR Slope++, Size 3.5, 9mm
02-013-49-3511	Logic Tibial Insert Trial, CR Slope++, Size 3.5, 11mm
02-013-49-3513	Logic Tibial Insert Trial, CR Slope++, Size 3.5, 13mm
02-013-59-4009	Logic Tibial Insert Trial, CR Slope++, Size 4, 9mm
02-013-59-4011	Logic Tibial Insert Trial, CR Slope++, Size 4, 11mm
02-013-59-4013	Logic Tibial Insert Trial, CR Slope++, Size 4, 13mm
02-013-49-5009	Logic Tibial Insert Trial, CR Slope++, Size 5, 9mm
02-013-49-5011	Logic Tibial Insert Trial, CR Slope++, Size 5, 11mm
02-013-49-5013	Logic Tibial Insert Trial, CR Slope++, Size 5, 13mm
02-013-49-6011*	Logic Tibial Insert Trial, CR Slope++, Size 6, 11mm
02-013-49-6013*	Logic Tibial Insert Trial, CR Slope++, Size 6, 13mm



Catalog Number Part Description

02-019-10-0100** Logic Femoral Notch Cutting Guide, PS, Size 0
 02-019-10-0110 Logic Femoral Notch Cutting Guide, PS, Size 1
 02-019-10-0115* Logic Femoral Notch Cutting Guide, PS, Size 1.5
 02-019-10-0120 Logic Femoral Notch Cutting Guide, PS, Size 2
 02-019-10-0125 Logic Femoral Notch Cutting Guide, PS, Size 2.5
 02-019-10-0130 Logic Femoral Notch Cutting Guide, PS, Size 3
 02-019-10-0135 Logic Femoral Notch Cutting Guide, PS, Size 3.5
 02-019-10-0140 Logic Femoral Notch Cutting Guide, PS, Size 4
 02-019-10-0150 Logic Femoral Notch Cutting Guide, PS, Size 5
 02-019-10-0160** Logic Femoral Notch Cutting Guide, PS, Size 6



02-019-11-0000** Logic Femoral Notch Cutter, PS, Size 0
 02-019-11-0010 Logic Femoral Notch Cutter, PS, Size 1
 02-019-11-0015* Logic Femoral Notch Cutter, PS, Size 1.5
 02-019-11-0020 Logic Femoral Notch Cutter, PS, Size 2
 02-019-11-0025 Logic Femoral Notch Cutter, PS, Size 2.5
 02-019-11-0030 Logic Femoral Notch Cutter, PS, Size 3
 02-019-11-0035 Logic Femoral Notch Cutter, PS, Size 3.5
 02-019-11-0040 Logic Femoral Notch Cutter, PS, Size 4
 02-019-11-0050 Logic Femoral Notch Cutter, PS, Size 5
 02-019-11-0060** Logic Femoral Notch Cutter, PS, Size 6



213-70-00* LPI Tibial Tray Trials, Size 0
 213-70-10 LPI Tibial Tray Trials, Size 1
 213-70-15* LPI Tibial Tray Trials, Size 1.5
 213-70-20 LPI Tibial Tray Trials, Size 2
 213-70-25 LPI Tibial Tray Trials, Size 2.5
 213-70-30 LPI Tibial Tray Trials, Size 3
 213-70-35 LPI Tibial Tray Trials, Size 3.5
 213-70-40 LPI Tibial Tray Trials, Size 4
 213-70-45 LPI Tibial Tray Trials, Size 4.5
 213-70-50 LPI Tibial Tray Trials, Size 5
 213-70-60* LPI Tibial Tray Trials, Size 6

285-08-71 PTS Inserter Handle

285-08-72 PTS Hex Inserter



02-013-42-0008 Logic Proximal Tibial Spacer Trial, 8mm, Size 0
 02-013-42-1008 Logic Proximal Tibial Spacer Trial, 8mm, Size 1
 02-013-42-2008 Logic Proximal Tibial Spacer Trial, 8mm, Size 2
 02-013-42-2508 Logic Proximal Tibial Spacer Trial, 8mm, Size 2.5
 02-013-42-3008 Logic Proximal Tibial Spacer Trial, 8mm, Size 3
 02-013-42-3508 Logic Proximal Tibial Spacer Trial, 8mm, Size 3.5
 02-013-42-4008 Logic Proximal Tibial Spacer Trial, 8mm, Size 4
 02-013-42-5008 Logic Proximal Tibial Spacer Trial, 8mm, Size 5
 02-013-42-6008 Logic Proximal Tibial Spacer Trial, 8mm, Size 6





OPTETRAK
LOGIC[®]

REFERENCES

1. **Bellemans J, Robijns F, Duerinckx J, Banks S, Vandenneucker H.** The influence of tibial slope on maximal flexion after total knee arthroplasty. *Knee Surgical Sports Traumatol Arthroscopy.* (2005) 13: 193–196.

Exactech is proud to have offices and distributors around the globe.
For more information about Exactech products available in your country, please visit www.exac.com

For additional device information, refer to the Exactech Optetrak® Logic® Knee System—Instructions for Use for a device description, indications, contraindications, precautions and warnings. For further product information, please contact Customer Service, Exactech, 2320 NW 66th Court, Gainesville, Florida 32653-1630, USA. (352) 377-1140, (800) 392-2832 or FAX (352) 378-2617.

Exactech, as the manufacturer of this device, does not practice medicine, and is not responsible for recommending the appropriate surgical technique for use on a particular patient. These guidelines are intended to be solely informational and each surgeon must evaluate the appropriateness of these guidelines based on his or her personal medical training and experience. Prior to use of this system, the surgeon should refer to the product package insert for comprehensive warnings, precautions, indications for use, contraindications and adverse effects.

The products discussed herein may be available under different trademarks in different countries. All copyrights, and pending and registered trademarks, are property of Exactech. This material is intended for the sole use and benefit of the Exactech sales force and physicians. It should not be redistributed, duplicated or disclosed without the express written consent of Exactech.
©2012 Exactech.

352-377-1140
1-800-EXACTECH
www.exac.com



712-25-31 Rev. B
Logic CR LPI Operative Technique 0113