

E354755

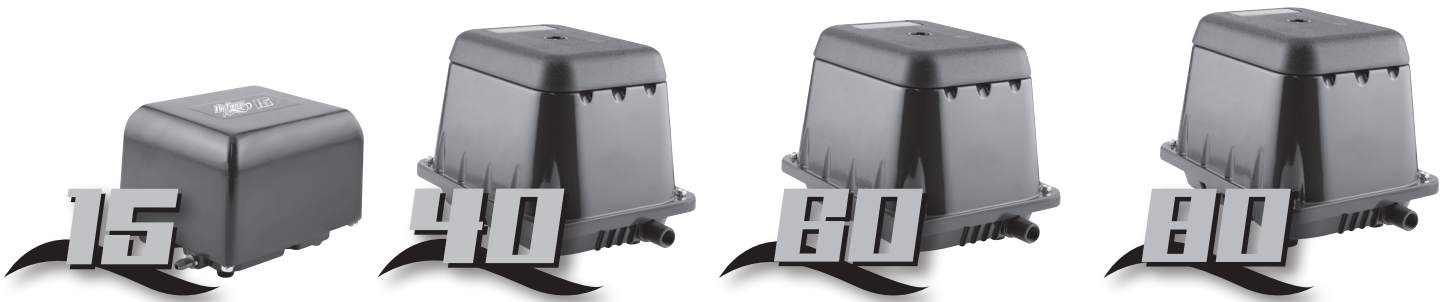

models



LINEAR AIR PUMP

Oil-Less Compressor

Operation & Maintenance Manual

IMPORTANT:

PLEASE READ THIS MANUAL COMPLETELY.
SAVE THIS MANUAL FOR FUTURE REFERENCE AND KEEP IN CLOSE
PROXIMITY TO THE AIR PUMP.

Thank you for purchasing Air Force Pro™ Linear Air Pumps.
It is manufactured to the highest standards using quality
materials. Please follow all recommended maintenance,
operational and safety instructions and you will receive
years of trouble free service.

WARNING

- ※ **IMPORTANT SAFEGUARDS — READ AND FOLLOW ALL SAFETY INSTRUCTIONS**
- ※ **TO REPLACE OR CHANGE ANY OF THE PARTS REFERRED IN THE SERVICE MANUAL, WE STRONGLY RECOMMEND YOU CONTACT AN AUTHORIZED TECHNICIAN.**

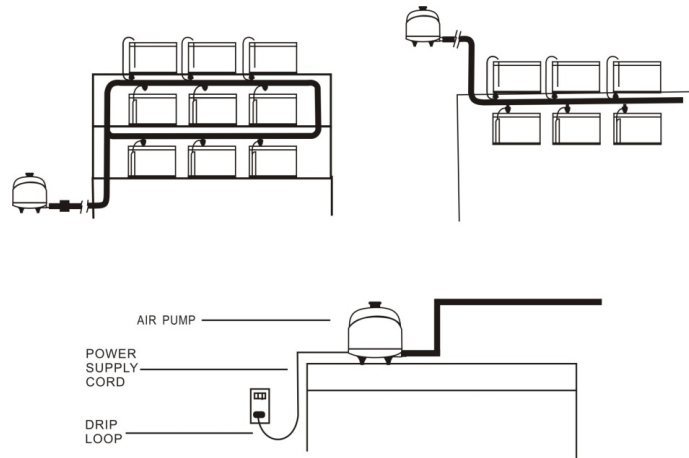

DANGER --To avoid possible electric shock, special care should be taken since water is used with or near aquariums and reservoirs. For each of the following situations **DO NOT** attempt repairs yourself, instead return the air pump to the retailer where you purchased the pump for servicing or discarding of the pump.

Precautions for pump use:

- 1) If the pump falls into the water, **DO NOT REACH FOR IT**. First unplug the pump and then retrieve it. If the pump's electrical components get wet, unplug the pump immediately.
- 2) Carefully examine the air pump after installation. It should **NOT** be plugged in if there is water present on any of the pumps parts.
- 3) **DO NOT** operate if the cord or plug is damaged.
- 4) **DO NOT** operate if the pump is malfunctioning, dropped, or damaged in any way.
- 5) To prevent the plug or electrical outlet from getting wet, position the aquarium tank or reservoir stand to one side of a wall mounted outlet. A "drip loop" shown in the figure above, should be arranged for each cord connecting an air pump to an electrical outlet. The "drip loop" is the part of the cord below the level of the outlet or connector if an extension cord is used. The "drip loop" prevents water from traveling along the cord from coming into contact with the outlet.

- 6) If the plug or outlet does get wet DO NOT UNPLUG THE CORD; Disconnect the fuse or circuit breaker supplying power to the pump, then unplug and examine for the presence of water in the outlet.
- 7) DO NOT use the pump near volatile liquids such as gasoline, thinners, etc., as this creates the possibility of an explosion.

CAUTIONS FOR USE

- 1) Close supervision is necessary when an air pump is used by or near children.
- 2) This pump is intended for **clean, dry air only**. DO NOT, under any circumstances, attempt operation with water or other liquids, otherwise pump may be damaged.
- 3) The ambient operating temperature for this pump is between 41°F(5°C) and 104°F(40°C). Operation of pump in temperatures outside the recommended temperature range may result in malfunction or severely shortened service life.
- 4) DO NOT block the air from being discharged. Air pumps must have sufficient room to allow for heat dissipation.
- 5) Failure to observe cautions will cause the pump to automatically switch off until cool.

**DO NOT REMOVE PUMP CASING UNLESS UNIT IS DISCONNECTED
FROM MAIN POWER SUPPLY.**

- 6) Always unplug pump prior to servicing. Grasp plug to remove cord from outlet. DO NOT remove by pulling on power cord.
- 7) DO NOT use the air pump for other than its intended use. The use of attachments not recommended or not sold by Sunlight Supply, Inc may cause an unsafe condition.
- 8) DO NOT install pump where it will be exposed to weather.
- 9) DO NOT store pump in temperatures below freezing.
- 10) Ensure pump is securely mounted prior to operation.
- 11) Read and observe all important markings on pump.
- 12) Ensure that extension cords (if required) have the correct or higher rating (amperes or watts). Ensure cord is properly positioned to avoid tripping.
- 13) To avoid injury, DO NOT contact moving parts or hot parts.
- 14) Always unplug an appliance from an outlet before putting on or taking off parts, before cleaning and when not in use

SAVE THESE INSTRUCTIONS

GROUNDING INSTRUCTIONS

- 1) For all grounded, cord-connected products:

This product must be properly grounded. In the event of an electrical short circuit, grounding reduces the risk of electric shock by providing an escape wire for the electric current. This product is equipped with a cord having a grounding wire with an appropriate grounding plug. The plug must be plugged into an outlet that is properly installed and grounded in accordance with all local codes and ordinances.

WARNING – Improper installation of the grounding plug may cause a risk of electric shock. Failure to follow these instructions can result in death, fire, or electrical shock. When repair or replacement of the cord or plug is required, do not connect the grounding wire to either flat blade terminal. The wire with insulation having an outer surface that is green with or without yellow stripes is the grounding wire.

Check with a qualified electrician or serviceman when the grounding instructions are not completely understood, or when in doubt as to whether the product is properly grounded. Do not modify the plug provided; if it does not fit the outlet, have the proper outlet installed by a qualified electrician.

This product is for use on a 120-V circuit, and has a grounding plug similar to the plug illustrated in Figure 1.

Figure 1: Grounding methods

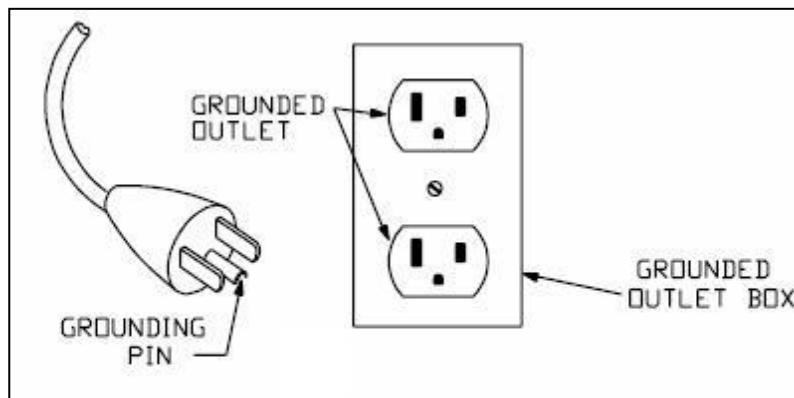

2) Extension Cords:

Use only a 3-wire extension cord that has a 3-blade grounding plug, and a 3-slot receptacle that accepts the plug on the product. Make sure your extension cord is not damaged. When using an extension cord, be sure to use one heavy enough to carry the current your product draws. An undersized cord results in a drop in line voltage and loss of power and overheating. (NOTE: Table 1 shows the correct size to use depending on cord length and nameplate ampere rating. When in doubt, use the next heavier gauge. The smaller the gauge number, the heavier the cord.)

Exception: A 2-conductor or 3-conductor extension cord may be used for a double-insulated or 2-wire product.

**Table 1
Minimum gauge for extension cords**

Ampere Rating Range	Voltage	Length of cord in ft								
	120V	25 ft	50 ft	100 ft	150 ft	200 ft	250 ft	300 ft	400 ft	500 ft
	240V	50 ft	100 ft	200 ft	300 ft	400 ft	500 ft	600 ft	800 ft	1000 ft
0 – 2		18	18	18	16	16	14	14	12	12
2 – 3		18	18	16	14	14	12	12	10	10
3 – 4		18	18	16	14	12	12	10	10	8
4 – 5		18	18	14	12	12	10	10	8	8
5 – 6		18	16	14	12	10	10	8	8	6

OPERATION

Use only recommended air handling parts acceptable for pressure not less than 10 psi. When provided, motor terminal covers must be in place for safe operation. Product surfaces may become hot during operation. DO NOT direct air stream at body. Air stream from product may contain solid or liquid material that can result in eye or skin damage, wear proper eye protection. DO NOT spray flammable or combustible liquid. Failure to follow these instructions can result in burns, eye injury or other serious injury.

It is your responsibility to operate this product at recommended duty pressure and ambient room temperature.

Start Up

If pump fails to start or slows down significantly under load, shut off and disconnect from power supply. Check that the voltage is correct for the pump.

MAINTENANCE

Disconnect electrical power supply cord before performing maintenance on this product. Failure to follow these instructions can result in death, fire or electrical shock. Product surfaces may become hot during operation; allow product surfaces to cool before handling. DO NOT direct air stream at body. Air stream from product may contain solid or liquid material that can result in eye or skin damage, wear proper eye protection. Clean this product in a well ventilated area. Failure to follow these instructions can result in burns, eye injury or other serious injury.

It is your responsibility to:

- Regularly inspect and make necessary repairs to product in order to maintain proper operation.
- Make sure that pressure is released from product before starting maintenance.
- NEVER add oil to this oil-less compressor.

Check intake filter after first 500 hours of operation. Clean filter and determine how frequently filter should be checked during future operation. This one procedure will help to assure the product's performance and service life.

Cleaning

DO NOT use kerosene or ANY other combustible solvent to clean product.

1. Remove filter and clean using detergent and water.
2. Rinse filter well and air dry.

Check that all external accessories such as relief valves and gauges are attached to cover and are not damaged before re-operating product.

Maintenance Manual

Air Force Pro™ 15

Part No: 746500

IMPORTANT: To open upper enclosure, please make sure you have unplugged the power cord before opening.

1. To change the diaphragms

- A. Remove the four screws around the aluminum upper housing, and take the housing off. (As shown in figure 1)
- B. Remove the four screws from the diaphragm housing. (As shown in figure 2)
- C. Remove the u-nut in the center of diaphragm.
- D. Take the diaphragm off its place.
- E. Replace a new one by mounting the rubber studs into their position.
- F. Press the rim of the diaphragm into the ring.
- G. Secure the magnet with a new u-nut and screw and put the diaphragm housing back with the four screws on.

*Replacement part Information

Model	Diaphragm Service kit
Air Force Pro™ 15 Part No: 746500	Part No: 746530

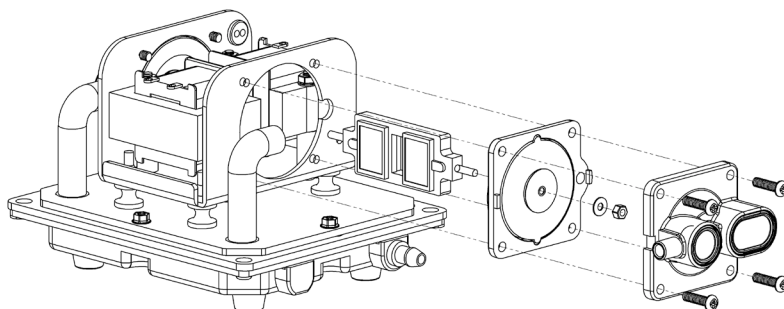

Figure 2

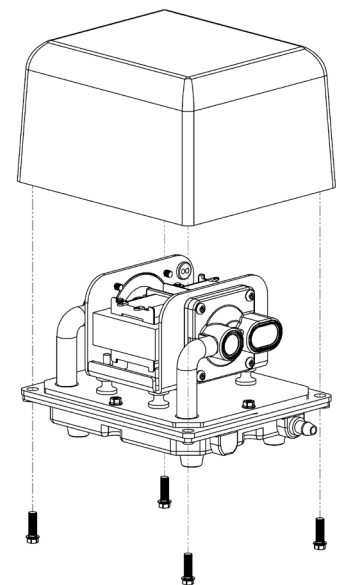
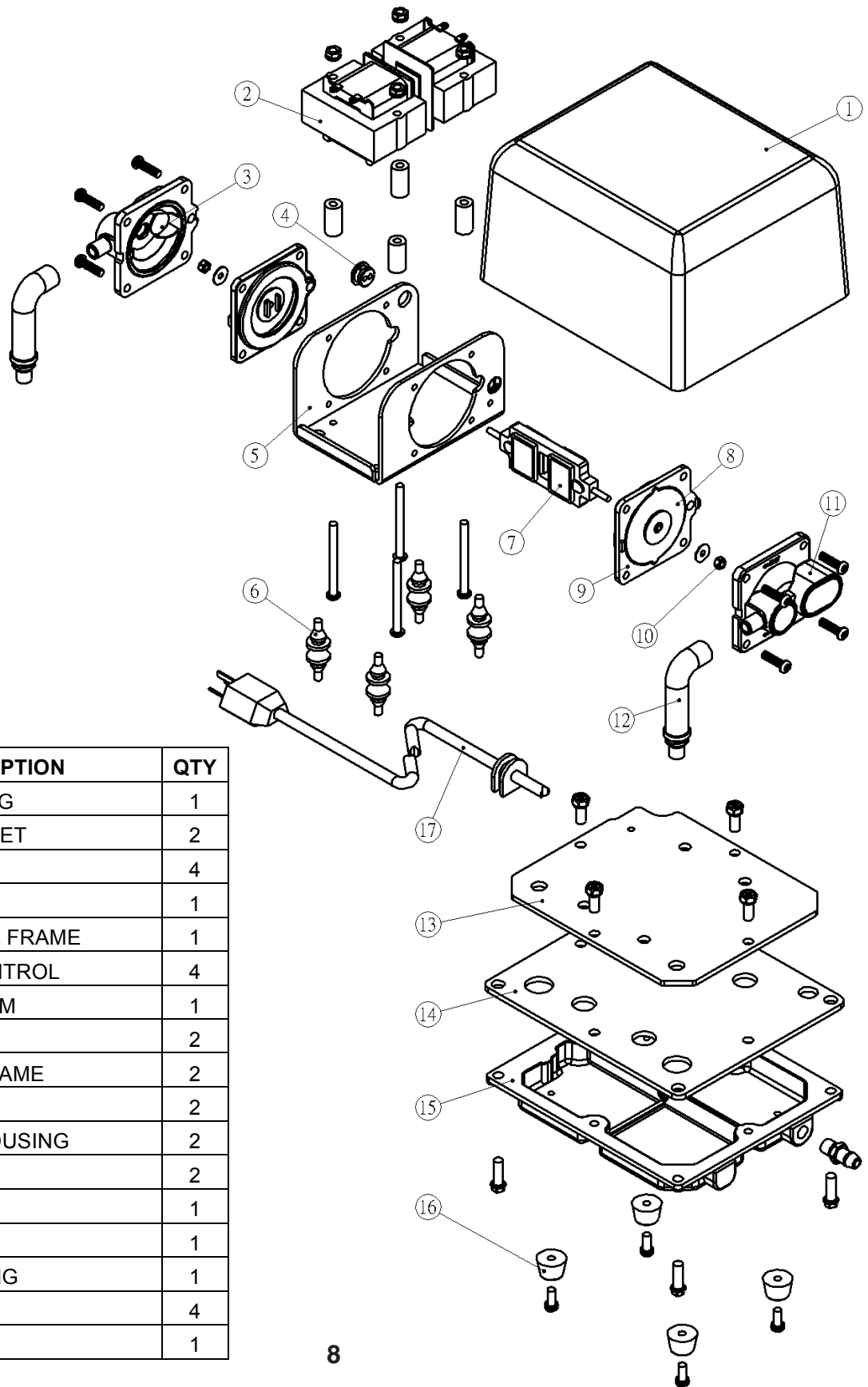

Figure 1

Product View and Parts List

Air Force Pro™ 15

Part No: 746500



NO.	DESCRIPTION	QTY
1	UPPER HOUSING	1
2	ELECTROMAGNET	2
3	CHECK VALVE	4
4	WIRE STOPPER	1
5	U-SHAPED COIL FRAME	1
6	VIBRATION CONTROL	4
7	ACTIVATING ARM	1
8	DIAPHRAGM	2
9	DIAPHRAGM FRAME	2
10	U NUT	2
11	DIAPHRAGM HOUSING	2
12	L - TUBE	2
13	STEEL PLATE	1
14	GASKET	1
15	LOWER HOUSING	1
16	RUBBER FEET	4
17	POWER CORD	1

Product Specifications

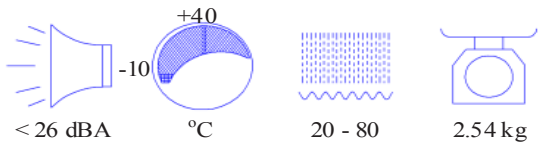

Part No.	Voltage (VAC)	Frequency (HZ)	AMP (A)	WATT (W)
746500	110 ~ 120	60	0.43	20

NOTES:

1. All dimensions are for reference only.
2. Technical data subject to change without notice

Performance

★ Allowance : $\pm 5\%$

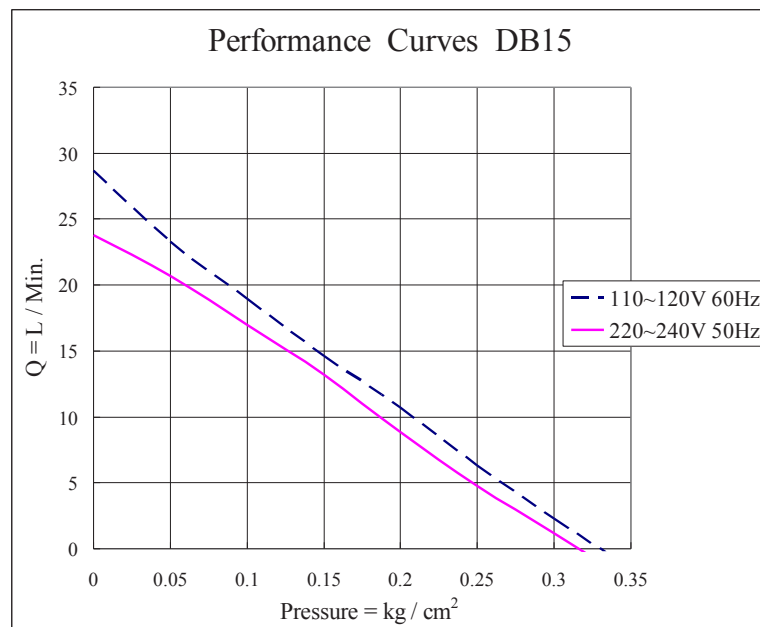

Dimensions (mm)

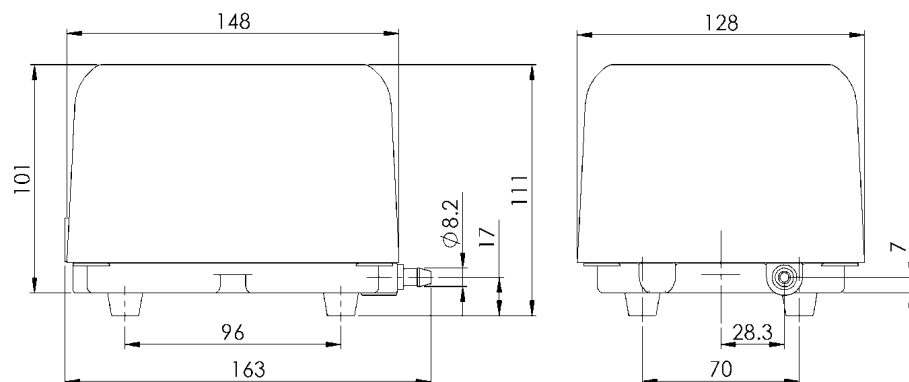

Maintenance Manual

Air Force Pro™ 40, 60, 80

Part No: 746505, 746510, 746515

1. To clean the air filter (Recommended once every six months)

- Remove the screw on top. (As shown in Figure1)
- Remove filter cover.
- Take the filter out and clean it with clean water and dry it.
- Put it back and secure the fixing plate with the screw in.

IMPORTANT: To open upper enclosure, please make sure you have unplugged the power cord before opening.

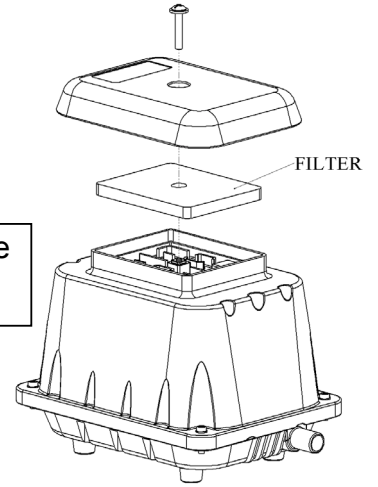

2. To change the diaphragms

- Remove the four screws around the aluminum upper housing, and take the housing off. (As shown in figure 2)
- Remove the four screws from the diaphragm housing. (As shown in figure 3)
- Remove the u-nut in the center of diaphragm.
- Take the diaphragm off its place.
- Replace a new one by mounting the rubber studs into their position.
- Press the rim of the diaphragm into the ring.
- Secure the magnet with a new u-nut and screw and put the diaphragm housing back with the four screws on.

Figure 1

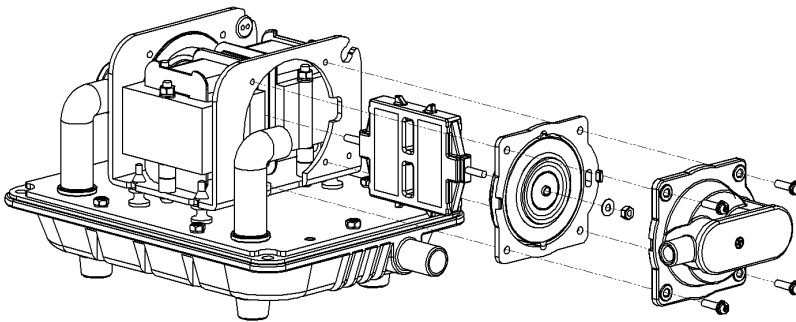

Figure 3

*Replacement part information.

Model Type	Diaphragm service kit	Air filter service kit
Air Force Pro™ 40 Part No: 746505	Part No: 746520	Part No: 746535
Air Force Pro™ 60 Part No: 746510	Part No: 746525	Part No: 746535
Air Force Pro™ 80 Part No: 746515	Part No: 746525	Part No: 746535

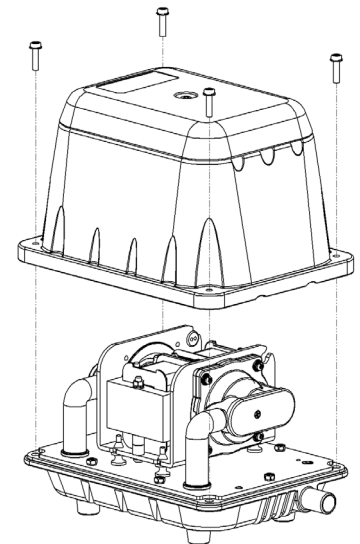
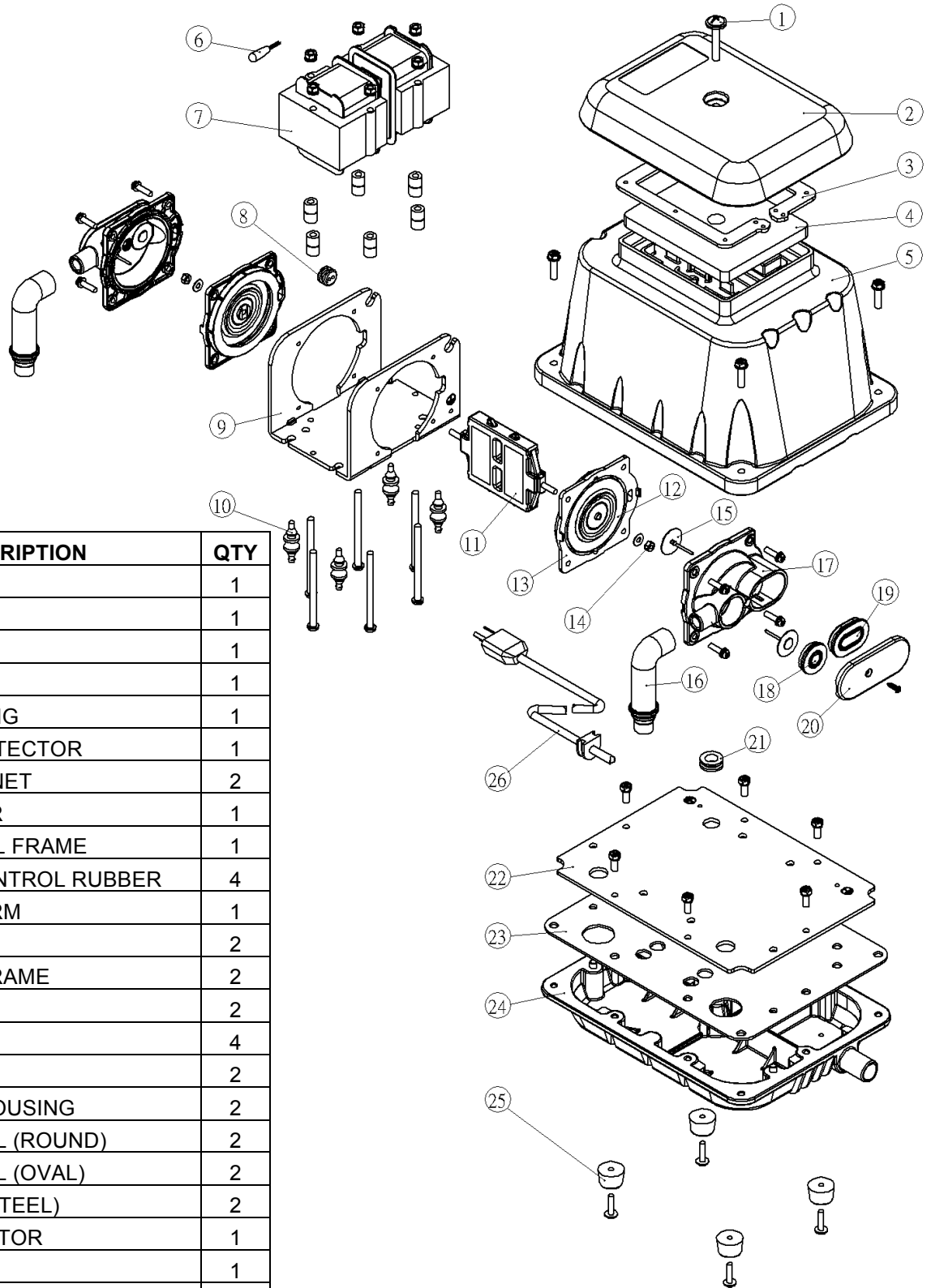

Figure 2

Product View and Parts List

Air Force Pro™ 40, 60, 80

Part No: 746505, 746510, 746515



NO.	DESCRIPTION	QTY
1	TOP SCREW	1
2	FILTER COVER	1
3	FOAM SEAL	1
4	FILTER	1
5	UPPER HOUSING	1
6	THERMAL PROTECTOR	1
7	ELECTROMAGNET	2
8	WIRE STOPPER	1
9	U-SHAPED COIL FRAME	1
10	VIBRATION CONTROL RUBBER	4
11	ACTIVATING ARM	1
12	DIAPHRAGM	2
13	DIAPHRAGM FRAME	2
14	U NUT	2
15	CHECK VALVE	4
16	L - TUBE	2
17	DIAPHRAGM HOUSING	2
18	CHAMBER SEAL (ROUND)	2
19	CHAMBER SEAL (OVAL)	2
20	SIDE COVER (STEEL)	2
21	CORD PROTECTOR	1
22	STEEL PLATE	1
23	GASKET	1
24	LOWER HOUSING	1
25	RUBBER FEET	4
26	POWER CORD	1

Product Specifications

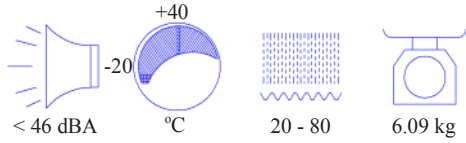

Part No.	Voltage (VAC)	Frequency (HZ)	AMP (A)	WATT (W)
746505	110 ~ 120	60	1.1	45

Performance

NOTES:

- All dimensions are for reference only.
- Technical data subject to change without notice.

★ Allowance : $\pm 5\%$

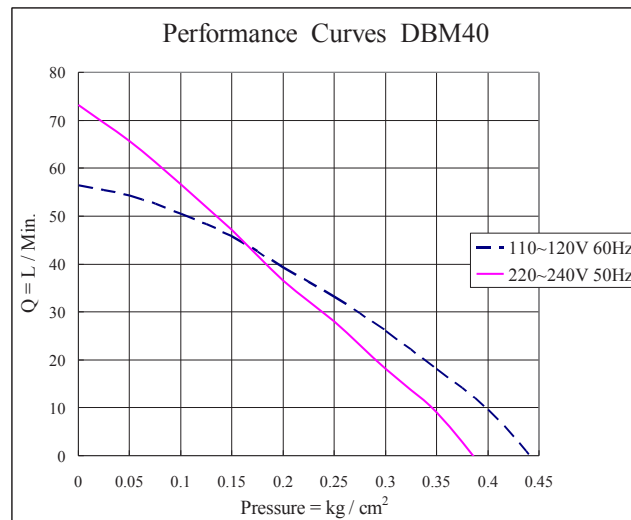

Dimensions (mm)

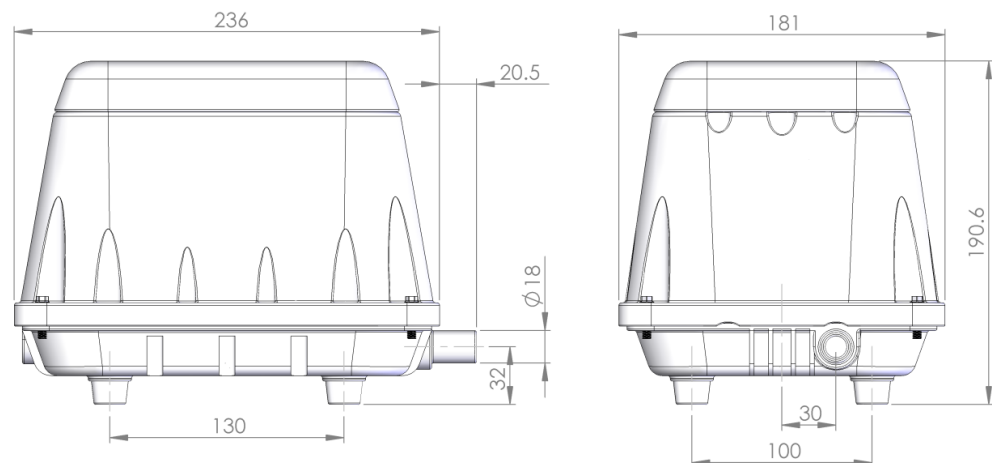

Product Specifications

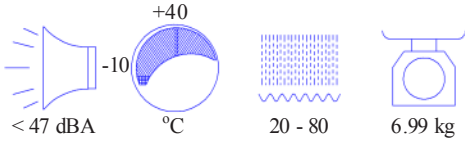

Part No.	Voltage (VAC)	Frequency (HZ)	AMP (A)	WATT (W)
746510	110 ~ 120	60	1.7	63

Performance

NOTES:

1. All dimensions are for reference only.
2. Technical data subject to change without notice.

★ Allowance : ±5%

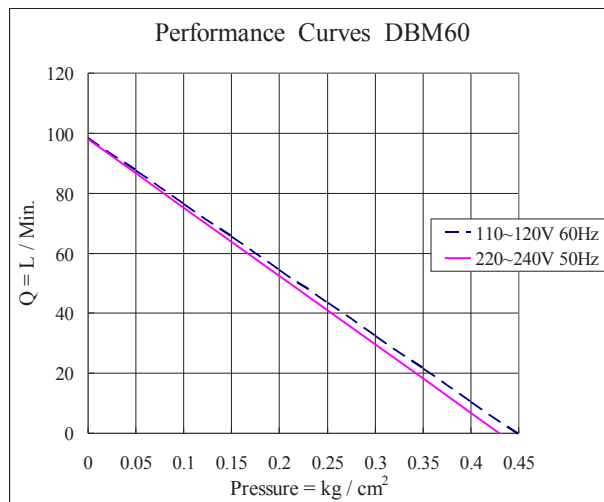

Dimensions (mm)

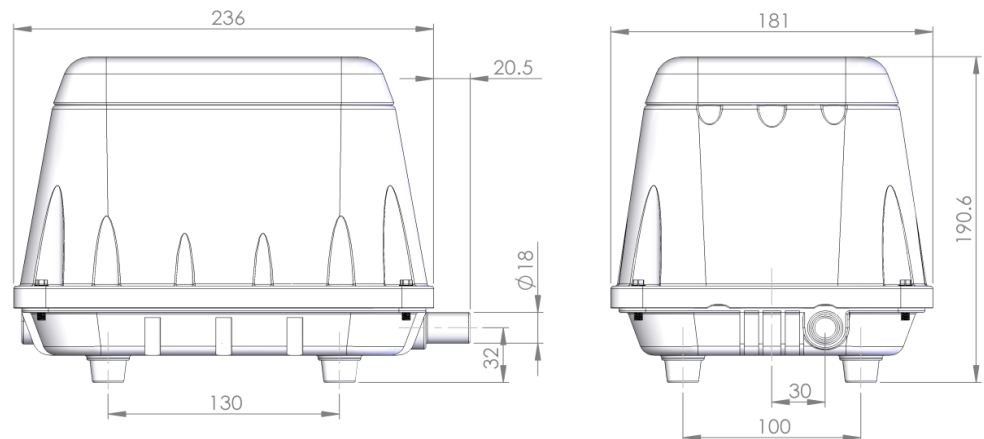

Product Specifications

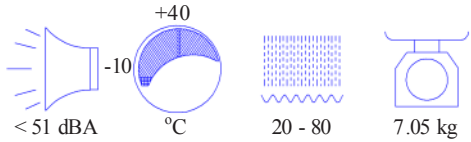

Part No.	Voltage (VAC)	Frequency (HZ)	AMP (A)	WATT (W)
746515	110 ~ 120	60	1.9	84

Performance

NOTES:

1. All dimensions are for reference only.
2. Technical data subject to change without notice.

★ Allowance : $\pm 5\%$

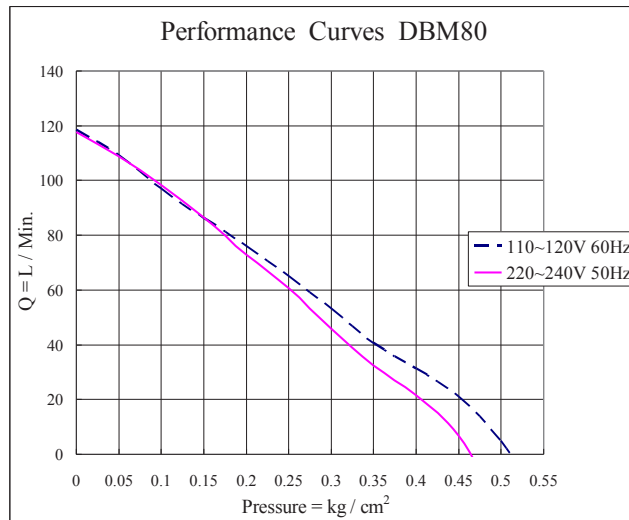

Dimensions (mm)

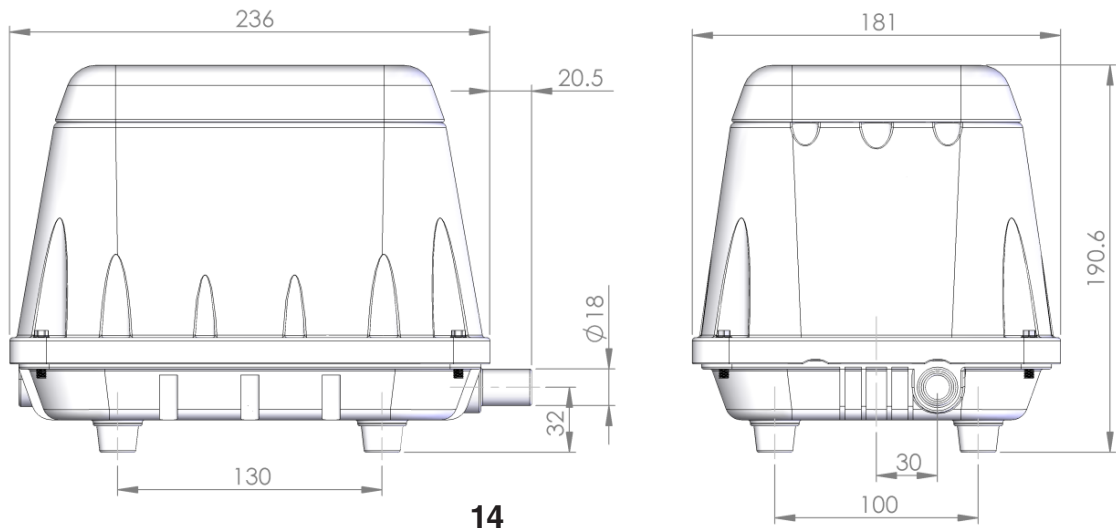

Limited Warranty

Thank you for choosing Air Force Pro™ Linear Air Pumps from Sunlight Supply, Inc. This unit is built to the highest standards using quality materials. To ensure the life and performance of your Air Force Pro™ Linear Air Pump a change of the diaphragm and air filter every year is absolutely necessary for users. Abuse or neglect will void the warranty.

TWO-YEAR LIMITED WARRANTY. The Air Force Pro™ 15, 40, 60, 80 Linear Air Pump covered in this manual, is warranted under normal use for two years after purchase date. Any part determined defective in material or workmanship can be returned with a receipt of purchase to the retail store where it was purchased. Product under warranty will be repaired or replaced.

LIMITATION OF LIABILITY. To the extent allowable under applicable law, liability consequential and incidental damages are expressly disclaimed. Liability in all events is limited to and shall not exceed the purchase price paid.

WARRANTY DISCLAIMER. Product information in this literature is provided for the sole purpose of identification, and does state or imply that products are merchantable, or fit for a particular purpose, or that the products will conform to the descriptions.

PRODUCT SUITABILITY. Many jurisdictions have codes and regulations governing sales, construction, installation and /or use of products for certain purposes, which may vary from those in neighboring areas. While we attempt to assure that the products comply with such codes, it cannot guarantee compliance, and cannot be responsible for how the product is installed or used. Before purchase and use of a product, review the product applications, and all applicable national and local codes and regulations, and be sure that the product, installation, and use will comply with them.

Please read this manual and save for future reference.

This pump is Oil-less compressors requiring NO lubrication.

Consult your supplier before using at high altitudes.



Exclusively distributed by:
Sunlight Supply, Inc.
National Garden Wholesale®