

WAVEFORM MULTIPLIER

A single VCO on a synth is, to be honest, pretty boring. Generate rich multiple oscillator sounds by hooking it up to one of our multiplier boards. Design by David Ward-Hunt.

Many synthesisers, both mono and polyphonic, utilise two or more VCOs, slightly detuned, to generate a rich chorusing sound. Chorus or phasing treatment of a single VCO can go some way towards livening up the sound, but these tend to suffer from a rather repetitive sweep and on some units a considerable amount of background noise during periods of silence — not to mention aliasing when used with high frequency high harmonic content waveforms which any decent synthesiser is capable of producing.

The beauty of using two or more slightly detuned oscillators is that in addition to producing a full chorusing sound, the problems of background noise and bandwidth are eliminated. However, multiple VCOs don't come cheap! An alternative method of achieving a 'multiple oscillator sound' is to generate additional waveforms from the existing VCO output. If each of these 'new' waveforms is out of phase with the original and with each other, then a fuller sound will be heard. However, the richness of the sound from multiple oscillators comes not from the fact that they are out of phase with each other, but from the fact that the phase difference is continually changing — the ear perceives phase *change* rather than phase difference. Therefore it is necessary not only to have additional out-of-phase waveforms, but their phase differences should be continually moving with respect to each other and the original.

A Passing Phase

The circuit described here does just that. It will accept sawtooth, triangle or sine wave inputs, though with the latter two the output will bear little resemblance to the original waveform due to the circuit action: however, they are still useful



The picture shows how the prototype was mounted in a Teko Alba A23 case, but this is not essential and most people will build the boards into their synth.

sounds to experiment with. The circuit has been used successfully to treat the VCO sawtooth outputs from a number of synthesisers including the Transcendent, Digisound '80 and PE Minisonic; it has also been used with a Korg Sigma and Roland SH02 (see the interfacing notes below). The one disadvantage of the circuit (there has to be one, doesn't there?) is that for setting-up purposes, constructors will need access to a scope or a second VCO with which to adjust the circuit to produce the correct waveforms.

Using The Multiplier

The multiplier board is fed with the output from your existing VCO. With a sawtooth waveform fed to the circuit, the output is a series of six sawtooth waveforms each individually phase modulated and mixed with the original sawtooth from the VCO. One multiplier PCB (generating six 'new' waveforms) is used with each VCO. If you do have two or more VCOs each feeding a separate multiplier board the effect is outstanding, especially when the VCOs are tuned to form a

chord. The output from the multiplier(s) is then fed back to the synthesiser and treated by the VCF and VCA in the normal way.

Construction

The project consists of two PCBs. The first holds the modulation oscillators for phase modulating the multiplier; the second PCB holds the multipliers and associated circuitry. The reason for splitting the project into two PCBs is that one modulation PCB is sufficient to drive up to four multiplier PCBs. (In fact there is no reason why it wouldn't drive more; however, we believe that if you intend to use more than four multiplier boards, the small additional expense of another modulator is well worth it for adding an even richer sound.)

All the components are mounted on the two PCBs with the exception of two diodes which are mounted on a switch (thereby saving two wires from the PCB to the switch). The only external connections required are the VCO input and the output from the unit plus the power supply connections (see below) which ideally should

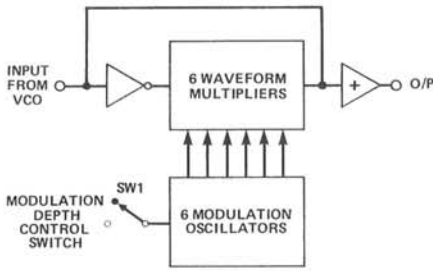

Fig. 1 Block diagram of the ETI Waveform Multiplier. Should you require an even richer sound, there's no reason why more than six multipliers shouldn't be used.

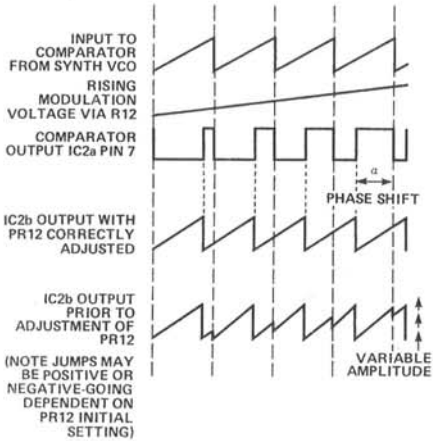

Fig. 2 The waveforms associated with various sections of the circuit. This indicates the operation of the unit and will also guide those people who are setting up the unit with an oscilloscope.

come from the same power supply as the VCO being input to the unit.

Interwiring between the PCBs should be clear from the diagram, as should the wiring up of the switch with its associated zener diodes. The switch is a DPDT with centre off and it is essential (for setting-up purposes if nothing else) to have this 'off' position (see Buylines).

A note is in order here about the component numbering. In order to make the numbering clearer and logically the same for each of the six multipliers on the PCB, each resistor or preset is designated by a two-figure number. The first figure indicates which of the six multipliers it is associated with, and the second is the 'relative number' of the component. For example, R11 is 'R1' on the first multiplier, R21 is 'R1' on the second multiplier, R35 is 'R5' on the third multiplier and so on.

With regard to the modulation PCB, though all the capacitors are of the same value, take care not to mix up the resistors associated with the two oscillators, as each oscillator should have all three of its resistors the same value. If not, the modulation output waveform will take on a pulse form at the output associated with the first op-amp in each oscillator.

PARTS LIST

MODULATION BOARD

Resistors (all $\frac{1}{4}$ W, 5%)

R1-3 1M8
R4-6 2M2

Capacitors

C1-8 100n polyester

Semiconductors

IC1 LM324
IC2 LM1458
ZD1,2 6V2 400 mW zener

Miscellaneous

SW1 DPDT with centre off (see Buylines)
PCB (see Buylines)

MULTIPLIER BOARD

Resistors (all $\frac{1}{4}$ W, 5%)

R1-3, 11,12,13,14, 15,16,21,22, etc to 66 100k (39 in total)
R4 18k

Potentiometers

PR11-61 100k miniature horizontal preset (six in total)
PR12-62 220k miniature horizontal preset (six in total)

Capacitors

C1,2 47u 16 V PCB electrolytic
C3-6 100n polyester

Semiconductors

IC1 LM1458
IC2-4 LM324
D1-6 1N4148

Miscellaneous

PCB (see Buylines); case to suit (Teko Alba A23); sockets to suit.

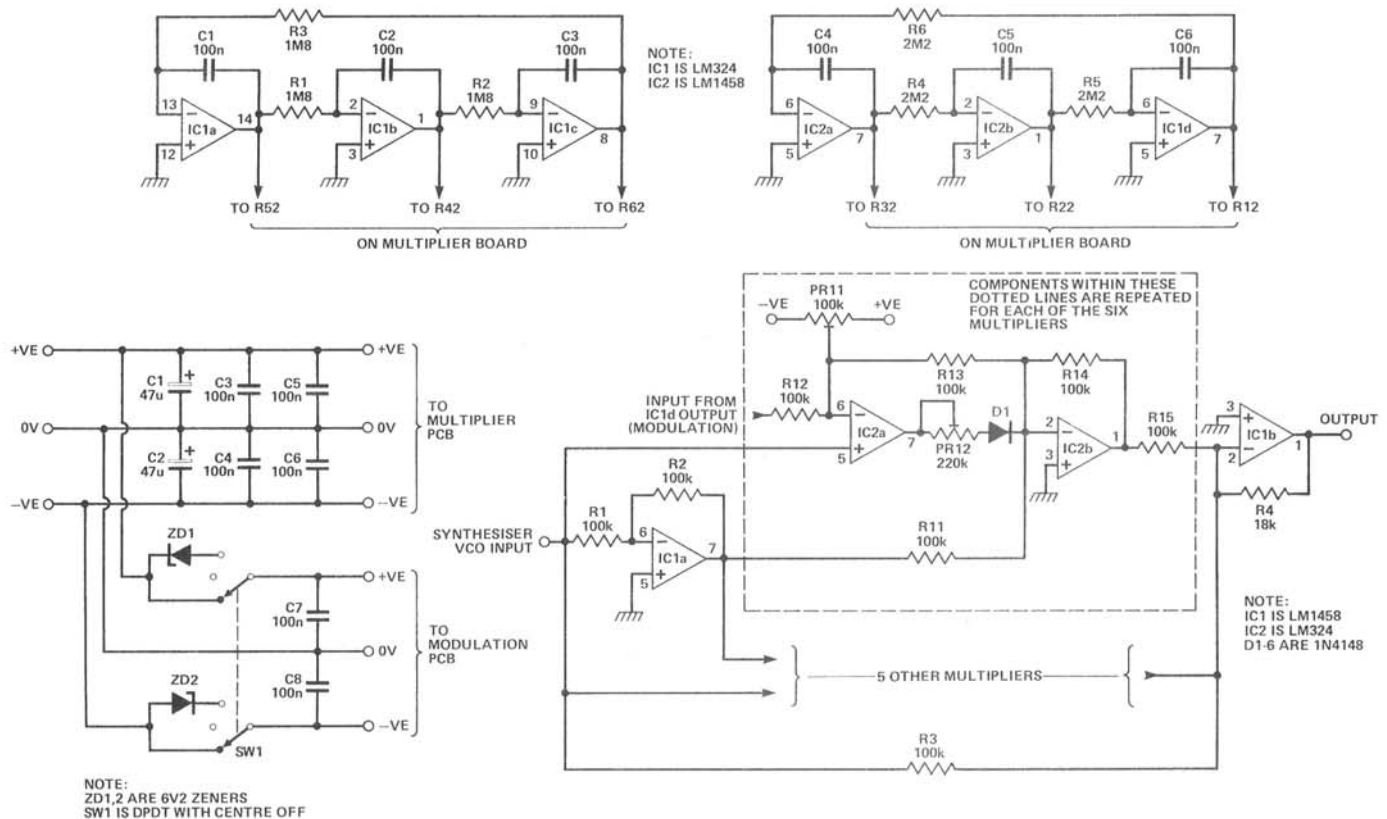

Fig. 3 Complete circuit diagram of the Waveform Multiplier.

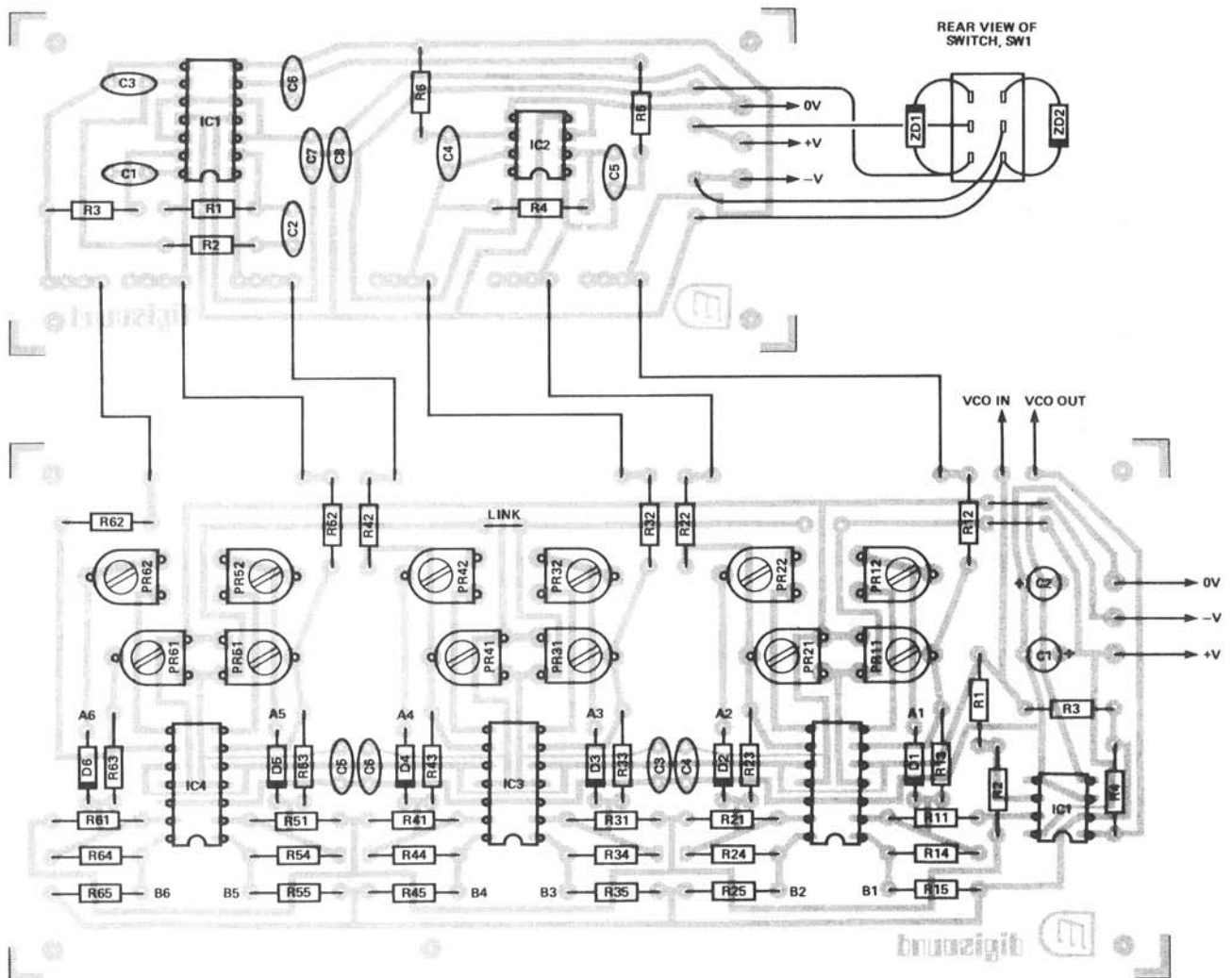

Fig. 4 Component overlays for the modulator board (top) and the multiplier board (bottom), and the interwiring required. Several multiplier boards may be driven from one modulator board.

HOW IT WORKS

The modulation oscillators are based on a standard three phase oscillator; two of these are used. Each of the three integrators in the loop outputs a waveform that is one-third of a cycle behind the others. The speed of the two oscillators is set at about 0.6 Hz and 0.4 Hz respectively. This modulation rate was found to give the best simulation of a number of oscillators running in free phase over a wide keyboard span.

It should be noted that the output of these oscillators is, in fact, a trapezoid shape waveform and it might be thought that some filtering would be required to produce a waveform more akin to a sine wave. This was tried in the development stage, but in practice the trapezoid waveform gave a better randomness to the overall output, whereas with a sine wave modulation a more definite sweep could be detected on long sustained notes.

Referring now to the multiplier circuit, the output from the synthesiser VCO is taken to IC1a configured as an inverter/buffer; the VCO waveform also goes to one input of the comparator IC2a. The other input of the comparator is fed with a voltage set up on PR11 together with the modulation voltage via

R12. With a positive-going sawtooth, the point at which the comparator goes high is determined by the sum of the fixed voltage from PR11 and the modulating voltage via R12. As shown in the waveform diagram, with a rising modulation voltage the width of the pulse at the comparator's output increases. However, the comparator will, of course, always reset at the same moment as the VCO sawtooth. Thus the comparator's reset is synchronised with the original sawtooth, whereas its positive-going excursion can be voltage-controlled to any point within one cycle of the input waveform.

The output of the comparator is rectified by D1 and summed with the inverted sawtooth from IC1a via R11. These voltages (actually currents) result in a new sawtooth whose reset point is determined by the positive-going edge of the comparator. Thus, as shown in the waveform diagram, this new sawtooth is phase-shifted from the original and the amount of phase shift is dependent on the comparator pulse width. The output of the summing amplifier IC2b is taken via R15 and mixed with the other multiplier outputs plus the original sawtooth (via R3), where IC1b acts as the mixing amplifier.

Setting Up

As stated earlier in the article, setting up requires access to an oscilloscope; you should have two VCOs and some method of listening to their output, but hopefully these requirements will not be a problem for most constructors.

Once all the components have been installed, ensure that the ICs, diodes and the two polarised capacitors are correctly orientated. All the ICs should be facing the same way and the diodes mounted on the PCB should have their band pointing towards pin 1/pin 14 of the ICs. Turn all the presets to their mid-position.

The setting up procedure is reasonably straightforward, though repetitive, since each of the six multipliers has two presets which need to be adjusted; however, your efforts will be rewarded! Constructors with access to a scope will find it easier to use the scope to see the various waveforms mentioned in the text. Those of you

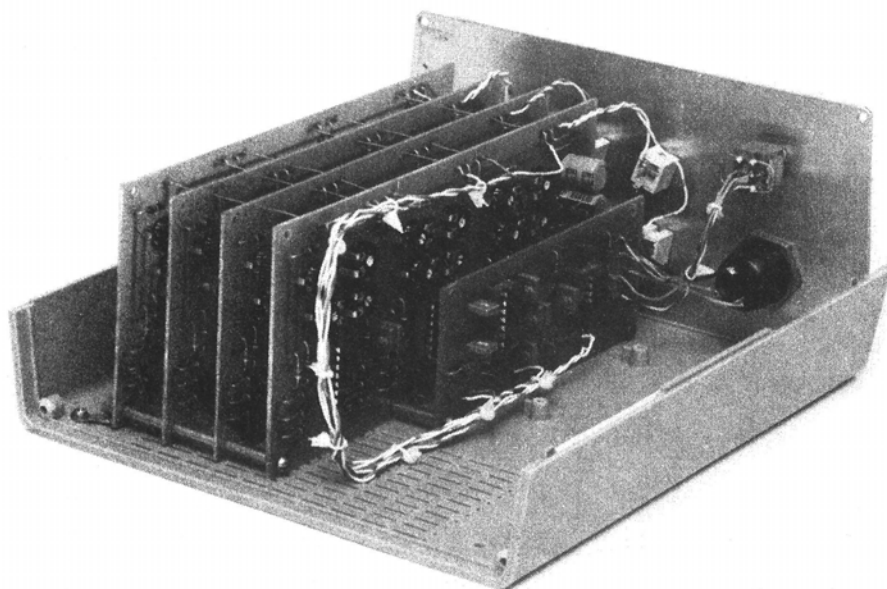

A view inside the prototype showing how it is configured to provide four independent channels driven by one modulator board. Miniature jack sockets are used for input and output (see also the lead photograph).

without a scope will be using your ears rather than your eyes, so make sure you have some means of listening handy. Either an amplifier and speakers, or headphones of reasonable quality will do, but remember we are listening to a 'raw' signal so don't stick it straight into your favourite hi-fi amp!

The first step is to power up the circuit and apply a VCO sawtooth waveform running at about 500 Hz (for ease of listening — so with a scope it doesn't matter). Ensure that the modulation switch is in the off position. Attach a lead to the output of IC1b (junction of pin 7 and R2). This should be outputting the VCO sawtooth (inverted). Next move the scope probe or audio lead to the junction of D1 and PR12 (marked A on the component overlay). This is the comparator output from which we want to get an approximate square wave output. At first you may hear no sound at all, but as PR11 is rotated you should hear a square wave break in with the pulse width varying as you turn the preset. Adjust PR11 for an approximate 50% duty cycle. (For

those unfamiliar with this sound, adjust PR11 for the 'loudest' sound. When the duty cycle is less than about 30% or more than about 70% a 'thin' spiky sound predominates, so set PR11 midway between these two — an accurate 50% is not important.) Repeat this step on each of the five other multipliers.

With the comparators now set up, we need to adjust the presets on the comparator outputs so as to give a smooth sawtooth waveform. PR12 is the preset associated with this adjustment. Attach your lead to the output of IC2b (junction of pin 1 and R15 — point B on the overlay). Until PR12 is correctly adjusted the sawtooth will contain a jump in it as shown in the waveform diagram. Using a scope, all you need to do is turn PR12 until this jump is smoothed out. Without a scope you will need two VCOs in order to accomplish this adjustment.

First, slow down the VCO which is connected to the circuit, to its lowest setting (somewhere around one cycle per second is fine). Now attach a lead from the aforementioned junction of pin 1 and R15 (point B) and run it to the FM input of your second VCO. If you now listen to the output of this second VCO it will be frequency-modulated by the sawtooth wave that we need to smooth out. So all you need to do now is turn PR12 until this second VCO gives a smooth upward frequency sweep followed by a sudden return to the starting frequency. This may sound difficult to perform but in fact it is surprising how easily the ear can detect any jumps in the modulating

waveform. However, if you are unsure of what a VCO sounds like when it is being frequency-modulated by a slow running sawtooth, listen to this effect on its own before trying to set up PR12. Again this adjustment is carried out on each of the six multipliers.

With all the multipliers now set up, speed up the VCO connected to the circuit, attach a lead to the output and you should see/hear a multiple sawtooth waveform. Now switch the modulators on (either setting of SW1) and you should hear a 'phasing' sound as the modulation builds up. Finally, check that the two 'on' positions of SW1 give different depths of modulation.

If, when the modulation switch is set to 'full' you find you can hear a distinct pause or break in one of the new waveforms, this indicates an incorrect setting of the preset associated with the comparator. To determine which one needs a finer adjustment, check each of the six multipliers by attaching an audio lead or probe to point B and adjust PR11, 21, 31 etc as appropriate, so that even with full modulation depth the comparator (and thus the sawtooth) remain within the range of one full cycle of the original sawtooth.

Interfacing Notes

The original circuit was developed for a Digisound 80 modular synthesiser; this has $\pm 15V$ supplies and a positive-going 0-10V VCO output. However, the circuit is fairly tolerant of a wide range of conditions and can be adapted to almost any synth with possibly some small additional components. The most likely problem concerns the ratio of the VCO output amplitude when compared with the voltage supply rails. The minimum and maximum supply voltages to the circuit described are $\pm 5V$ to $\pm 16V$. Bearing in mind these two limits, the waveform to be treated should be equal to or greater than one-third the sum of the voltage rails.

If the input waveform does not meet these requirements the obvious course is to add an op-amp to the front end of the circuit to bring the waveform up to the required level. For instance, with the PE Minisonic, which is pretty much a worst case, the power supply is $\pm 9V$, the VCO output is 1V peak-to-peak. In this case a simple $\times 6$ amplifier would do, but so as to allow plenty of headroom a $\times 8$ amplifier was made up. **ETI**

BUYLINES

A kit of parts for this project, comprising glass fibre PCB and all electronic components, is available from Digisound Ltd, 14-16 Queen Street, Blackpool, Lancs FY1 1PQ. The prices, inclusive of VAT and postage, are £10 for the multiplier and £6.05 for the modulator. Housing the project is entirely up to you and most people will simply fit the boards inside their synth, but we put ours into a Teko Alba A23 case to match the rest of the Project 80 modules. If you want to do likewise, the case is available from West Hyde, Unit 9, Park Street Industrial Estate, Aylesbury, Buck.

WAVEFORM MULTIPLIER

ETI ARTICLE. JANUARY 1983

No errors have been noted and in Figure 4 it is quite obvious that the unmarked IC on the Multiplier Board is IC2.

GENERAL

With the co-operation of David Ward-Hunt the Waveform Multiplier has been added to the DIGISOUND 80 range. While the cost for a single unit is over half that of an 80-2 VCO the advantage of the multiplier approach is that it produces a 'new' and consistent sound over a wide range.

DIGISOUND 80 users should, however, note the following points -

1. The power connections are not our standard CHIRI type but the PCB's will accept a screw connector shown on the price list as 'Mains 3-pin PCB connector'. One reason for this is that the power connections on the Multiplier Board do not follow our usual convention (also note that power connections are not in the same order on the modulator board).
2. At this time we do not have any plans to produce a panel for this kit. As can be seen from the cased unit in the article one only requires three holes for a single multiplier and the amount of printing is minimal. We do, however, supply blank panels and it would be quite practical to mount two multipliers on a single 3 inch wide panel. To simulate lettering used on our printed panels use 14pt (3.9mm) Helvetica Medium {Letraset Sheet No.729} for the main heading and 12pt (3.0mm) Helvetica Medium {Letraset Sheet No.1568} for the other lettering. Subsequent spraying of the panel with Letraset Matt will prevent scuffing of the lettering. When drilling the panel the best approach is to gradually increase the size of the hole. 1/4 inch or 6.5mm holes are required for both switch and 3.5mm jack sockets.

For customers with multiple VCO's it may be advantageous to have a larger panel - please let us know whether you wish to have 6 X 9 and 9 X 9 inch blank panels added to the range.