

Amana Technical Information—Refrigerator

SCD22TB

P1303511W

- Due to a possibility of personal injury or property damage, always contact an authorized technician for servicing or repair of this refrigerator.
- Refer to Service Manual RS1000001 for installation, disassembly, ice maker, safety, testing, and troubleshooting information.



CAUTION

All safety information must be followed as provided in Service Manual RS1000001.



WARNING

To avoid risk of electrical shock, personal injury, or death, disconnect power to refrigerator before servicing, unless testing requires power. Wires removed during disassembly must be replaced on proper terminals to insure correct earthing and polarization.

Model	SCD22TB
Capacity	22.14 cu ft
Electrical requirements separate circuit	115 VAC 60 Hz 15 amps
Refrigerant type	R134a
Width without side extrusions	35.75"
Depth without handle includes door extrusions	29.75"
Height including top hinge cap	68.5"





No Load Performance Controls in Normal Position

	Kw/24hr ± 0.4			Percent Run Time $\pm 10\%$			Cycles/24 hr $\pm 25\%$			Refrigerator Center Compartment Food Average Temperature $\pm 3^\circ\text{F}$			Freezer Compartment Food Average Temperature $\pm 3^\circ\text{F}$		
	65°	90°	110°	65°	90°	110°	65°	90°	110°	65°	90°	110°	65°	90°	110°
22 Cu Ft	1.	2.	4.	37.	50.	100.	37.	33.	0.	38.	40.	40.	1.	2.	2.

Temperature Relationship Test Chart

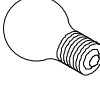
Ambient °F	T-1 Outlet $\pm 3^\circ\text{F}$		T-2 Inlet $\pm 3^\circ\text{F}$		T-3 Suction Line $\pm 7^\circ\text{F}$		Average Total Wattage $\pm 10\%$		Suction Pressure $\pm 2\text{ PSIG}$		Head Pressure $\pm 5\text{ PSIG}$	
	65°	90°	65°	90°	65°	90°	65°	90°	65°	90°	65°	110°
22 Cu Ft	-10.	-11.	-13.	-12.	67.	90.	161.	171.	1.	1.	85.	185.

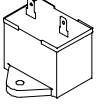
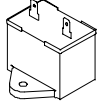
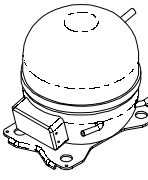
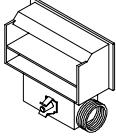
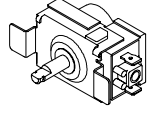
Component Specifications

Part Number	Component Name	Test Procedure
A0282803 	Bulb	Volt 115/125 VAC Watt 40 watts
M0360001 	Bulb	Volt 115/125 VAC Watt 6 watts
C8931604 	Capacitor, compressor run	Volt 220 VAC Capacitance 15 Mfd +10% -5%
C8931605 	Capacitor, auger motor	Volt 220 VAC Capacitance 17 Mfd +10% -5%
12049702 	Compressor	Type Fan Cooled, R134a refrigerant BTUH 970 BTUH Volt 115 VAC, 60 Hz Watt 176 watts Current Lock rotor 21.3 amps Full load 1.6 amps Resistance Run Windings 2.60 ohms Start Windings 4.35 ohms
D7547412 	Control, damper	Settings Closing temperatures #1 47°F #4 40°F #7 30°F
C3615024 	Control, freezer temperature	Settings Temperatures #1-in 21.0°F #1-out 4.5°F #4-in 13.3°F #4-out -5.9°F #7-in 9.8°F #7-out -11.0°F
B2150504 	Drier	Drier must be changed every time the system is opened for testing or compressor replacement. Desiccant (20) 8 x 12 4AXH - 7 M>S> -Grams
10882105	Heater, cavity	Volt 115 VAC Watt 5 ±7.5% watts Resistance 1.89 ±7.5% ohms
12049801	Heater, evaporator	Volt 115 VAC Wattage 450 ±5% watts Resistance 29 ±5% ohms

Component Specifications

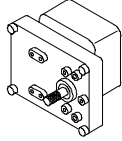
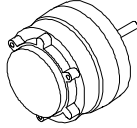
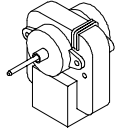
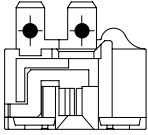
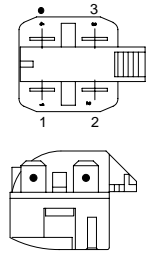
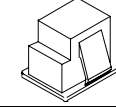
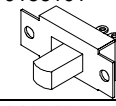
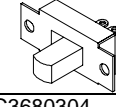
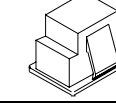
Part Number	Component Name	Test Procedure	
10114804 	Motor, auger	Volt Rotation (facing shaft) RPM Watt Bimetal Cut-out Opens Closes	115 VAC, 60 Hz Power to blue and white leads is clockwise Power to white and orange leads is counterclockwise 13-17 RPM 165- watts 266° ±9°C 1185° ±9°C
10884501 	Motor, condenser	Volt Rotation (facing end opposite shaft) RPM Watt Current Resistance	115 VAC, 60 Hz Clockwise 1300 RPM 10.0 watts 0.15 amps 220 ±10% ohms
10513803 	Motor, evaporator fan	Volt Rotation (facing end opposite shaft) RPM Watt	115 VAC, 60 Hz Clockwise 2500 RPM 12 ±15% watts
10377015 	Overload, 4TM	Volt Ult. trip amps @ 158°F (70°C) Close temperature Open temperature Short time trip (seconds) Short time trip (amps @77°F 25°C))	115 VAC 3.51 amps 142°F (61°C) ±9° 257°F (125°C) ±5° 10 seconds ±5 14 amps
10097202 	Relay, ptc	Resistance With power off check: Across terminals 2 & 3 Shorted Open	3-12 ohms 0 ohms Very high or infinite ohms
C3680306 	Switch, auger motor interrupt	Type Volt Current	DPST, NO 125/250 VAC 5/2.5 amps
10166101 	Switch, cavity light	Type Volt Current	SPDT 125 VAC 4 amps
10166103 	Switch, crushed/cubed	Type Volt Current	SPST 250 VAC 6 amps
C3680304 	Switch, light	Type Volt Current	DPST 125/250 VAC 5/2.5 amps

Component Specifications

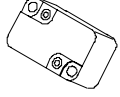
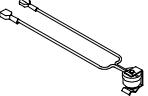
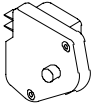
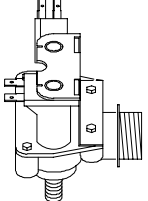
Part Number	Component Name	Test Procedure	
10533001 10533002 10533003 	Switch, limit and dispensing arms	Type Volt Current	SPSP, NO 125/250 VAC 10 amps
12017816 	Thermostat	Volt Watt Current Resistance across terminals Above 48° ±5°F Below 15° ±7°F Between 48° ±5°F and 15° ±7°F	120/240 VAC 1000 watts 10/5 amps Open Closed Will stay in current state (either open or closed) until either 48° ±6°F or 15° ±8°F is reached.
10530702 	Timer, defrost	Volt Defrost period (minutes) Defrost cycle (hours)	120 VAC, 60 Hz 33 ±3.6 8
D7742204 	Valve, water	Volt Watt Water pressure (inlet) Max Min Fill rate	120 VAC, 60 Hz 20 watts/per coil 120 PSI 20 PSI 140 ±10 CC's at 7.5 seconds

Schematic Diagram



WARNING

To avoid risk of electrical shock, personal injury, or death, disconnect power to refrigerator before servicing, unless testing requires power. Wires removed during disassembly must be replaced on proper terminals to insure correct earthing and polarization.



DANGER High Voltage

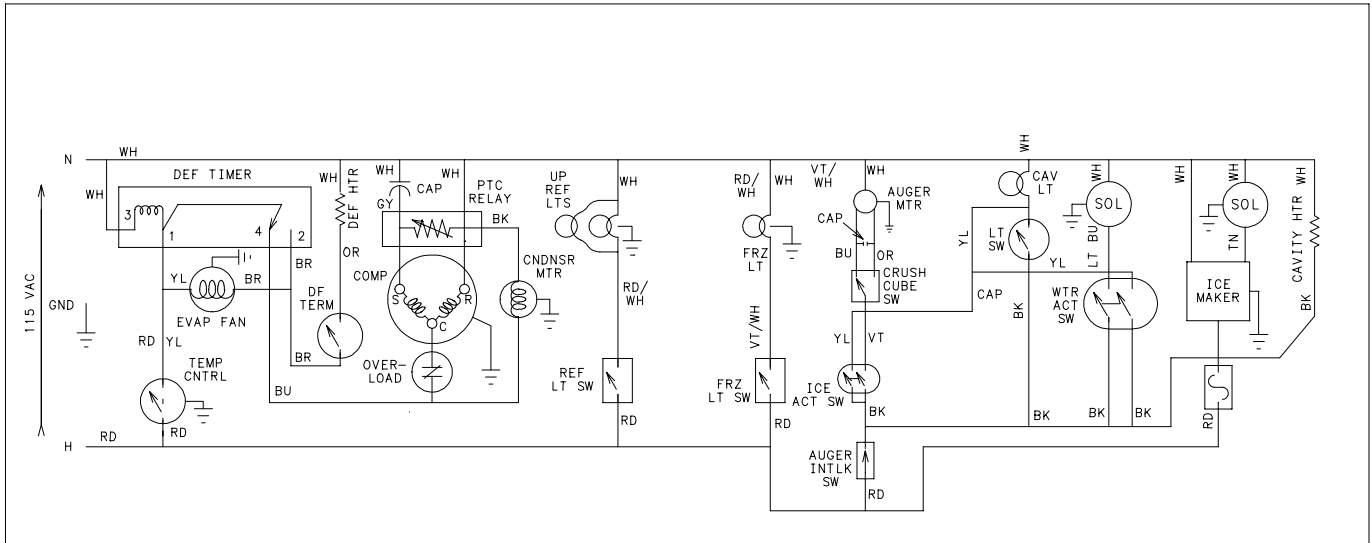

SCD22TB

P1303511W

Wiring Diagram



WARNING

To avoid risk of electrical shock, personal injury, or death, disconnect power to refrigerator before servicing, unless testing requires power. Wires removed during disassembly must be replaced on proper terminals to insure correct earthing and polarization.

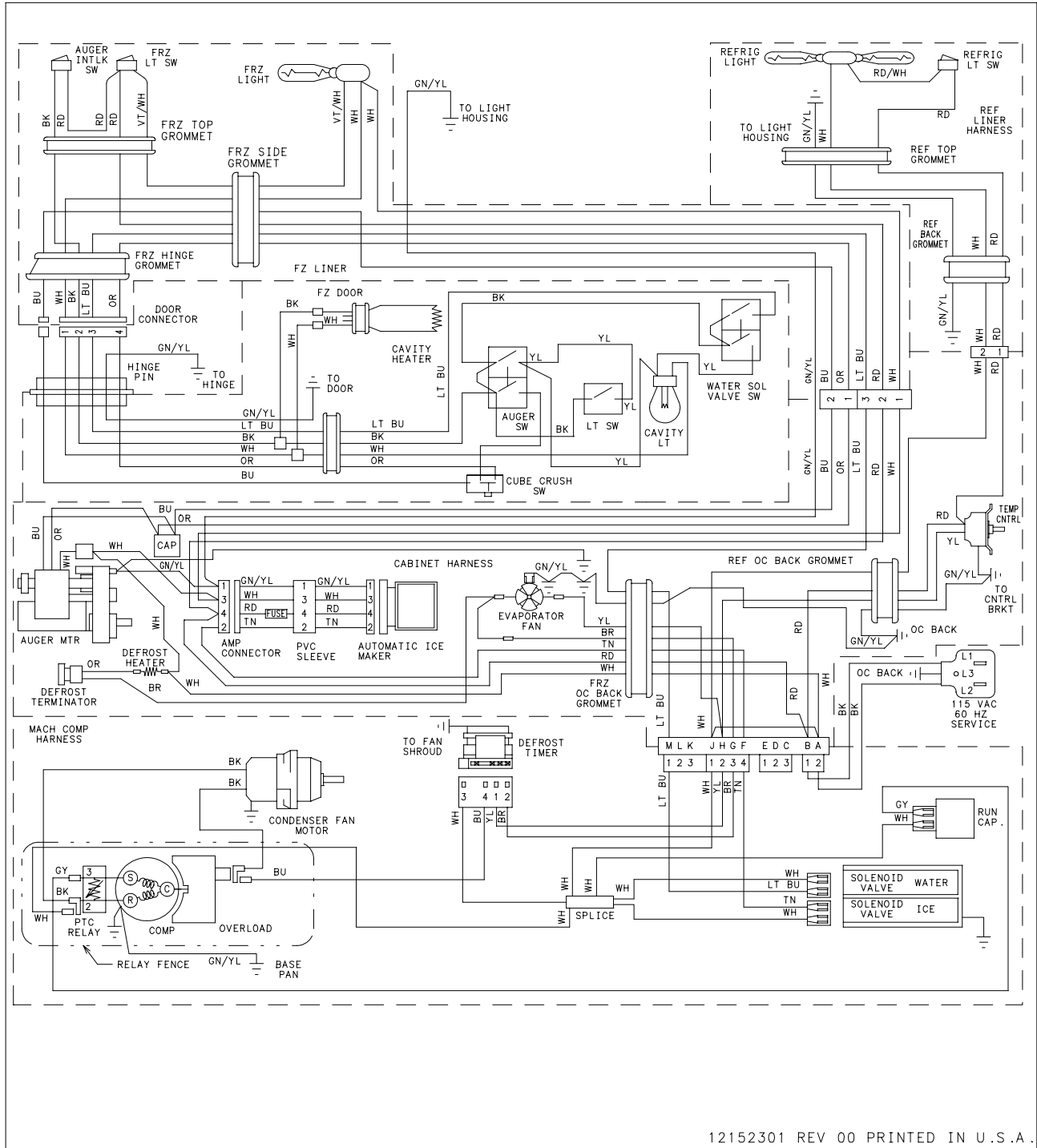

12152301 REV 00 PRINTED IN U.S.A.

SCD22TB

P1303511W