

**FEATURES**

- Energy saving luminaire with integrated occupancy controls
- Bi-level light control offers safety and security
- Ideal for stairwells, parking structures, restrooms and areas where maximum light levels are not needed when area is unoccupied
- A single low wattage 2' lamp delivers constant light output while the 4' lamps are controlled by an integral occupancy sensor
- White aluminum body allows for greater heat dissipation
- Tool-less access to ballast for ease of maintenance
- Can be surface mounted, wall mounted, or suspended
- Multiple ballast options available for needed energy savings and light output
- Fail safe operation switches light level to 100% if sensor is damaged
- Optional battery backup available for emergency egress applications

**PROJECT INFORMATION**

Project Name \_\_\_\_\_

Type \_\_\_\_\_

Catalog No. \_\_\_\_\_

Date \_\_\_\_\_

**HOUSING**

Steel fixture body.

**BALLASTS**

Energy efficient, thermally protected, automatic resetting, Class P, high power factor, sound rated A, magnetic or electronic ballasts. CEE NEMA Premium compliant.

**ELECTRICAL**

Standard class "P", thermally protected, autoresetting HPF ballast, sound rated A. CEE NEMA Premium compliant. All ballast leads extend a minimum of 6" through access location. NEC/CEC-compliant ballast disconnect is standard.

**LENS**

Highly efficient acrylic lens with a linear refractive pattern for even illumination and excellent lamp obscuration.

**OCCUPANCY SENSOR**

Hubbell Building Automation Internally mounted Passive Infrared Occupancy sensor. LED indicator for easy verification of coverage. Lens has a 1500 square-foot, 360° coverage area at a mounting height of 10 ft, and a 2:1 radius to height ratio coverage pattern. Sensor includes an adjustable time delay, and motion/photo cell sensitivity.

**CERTIFICATION**

All luminaires are built to UL 1598 standards and bear appropriate UL and cUL or CSA labels. Damp location labeling is standard. Units are UL 924 listed when equipped with optional battery back-up and meet requirements of the life safety code /NFPA101.

**ORDERING INFORMATION**

**EXAMPLE BIL4-232-EPLWU**

BIL		4	-	2	-	U	-	
MODEL	SIZE	LAMPS IN CROSS SECTION	LAMP TYPE	PRIMARY BALLAST	VOLTAGE	OPTIONS		
BIL Bi-Level Luminaire	4 4'	2 Two	<b>32</b> 4', T8: 32, 30, 28, or 25 Watt and 2', T8: 17 Watt <b>28</b> 4', T5: 28 Watt and 2', T5: 14 Watt <b>54</b> 4', T5HO: 54, 51 or 49 Watt and 2', T5: 14 Watt	<b>EP</b> Electronic T5, T5HO, 1.0 BF or T8 Programmed Start, 0.88 BF <b>EPLW</b> Electronic T8, Programmed Start, 0.77 BF <b>EPHL</b> Electronic T8, Programmed Start, 1.18 BF	U 120V-277V	<b>EL</b> Emergency Battery Pack, 2' lamp 500 lumens <sup>2</sup> <b>EL5</b> 390-750 Lumens, T5 1-Lamp <b>ELSH</b> 725-1250 Lumens, T5HO 1-Lamp <b>F0830</b> T8 Lamps Installed, 82 CRI, 3000K <b>F0835</b> T8 Lamps Installed, 82 CRI, 3500K <b>F5830</b> T5 or T5HO Lamps Installed, 85 CRI, 3000K <b>F5835</b> T5 or T5HO Lamps Installed, 85 CRI, 3500K <b>F5841</b> T5 or T5HO Lamps Installed, 85 CRI, 4100K <b>F5850</b> T5 or T5HO Lamps Installed, 85 CRI, 5000K <b>ODS1</b> Factory Installed Occupancy Sensor with daylight harvesting photosensor, 120/277/347V, one relay <sup>1</sup> <b>NYC</b> NYC Compliant <b>VH</b> (2) V-Hangers		
		UNOCCUPIED	OCCUPIED					
		(1) 17 WATT T8 LAMP	(1) 17 WATT T8 LAMP & (2) 32 WATT T8 LAMPS					
Ballast Type	Watts	Lumens	Watts	Lumens				
EP (0.88 BF)	15	989	74	4669				
EPLW (0.77 BF)	15	989	62	4208				
EPHL (1.18 BF)	15	989	90	5170				

<sup>1</sup> Use programmed start ballast. Not recommended for use with instant start. For more occupancy/daylight harvesting sensor accessories contact your Columbia Lighting representative.

<sup>2</sup> Voltage Required



## PHOTOMETRIC DATA

Test RWS-3-1x4-1L17-2L32-M4-CA-PHa Test Date 3/19/08

### LUMINAIRE DATA

Luminaire	BIL4-232-EPHLU Photometry based on Photopia software simulation. For relative photometry contact Columbia Lighting. Miro 4 Reflector Acrylic Lens
Ballast	Electronic T8
Ballast Factor	1.00
Lamp	F32T8
Lumens per Lamp	2383
Watts	100
Shielding Angle	N/A
Spacing Criterion	0°= 1.27 90°= 1.41
Luminous Opening in Feet	Length: 3.99 Width: 0.50 Height: 0.34

### ZONAL LUMEN SUMMARY

Zone	Lumens	%Lamp	%Fixt.
0-30	1041	14.6	20.1
0-40	1742	24.4	33.7
0-60	3241	45.3	62.6
0-90	4599	64.3	88.9
0-180	5175	72.4	100.0

### ENERGY DATA

Total Luminaire Efficiency	72.4%
Luminaire Efficacy Rating (LER)	N/A
IESNA RP-1-1993 Compliance	Noncompliant
Comparative Yearly Lighting Energy Cost per 1000 Lumens	\$N/A based on 3000 hrs. and \$0.08 per KWH

### COEFFICIENTS OF UTILIZATION (%)

RC	RW	80				70				50				0
		70	50	30	10	70	50	30	10	50	30	10	0	
1	75	71	67	64	72	69	65	62	64	61	59	50		
2	68	61	56	51	65	59	54	50	55	51	47	41		
3	61	53	47	42	59	51	46	41	48	43	39	34		
4	56	47	40	35	54	45	39	34	42	37	33	28		
5	51	42	35	30	49	40	34	29	38	32	28	24		
6	47	37	31	26	45	36	30	25	34	29	24	21		
7	44	34	27	23	42	33	27	22	31	25	21	18		
8	41	31	24	20	39	30	24	20	28	23	19	16		
9	38	28	22	18	36	27	21	18	26	21	17	15		
10	36	26	20	16	34	25	20	16	24	19	15	13		

### INDOOR CANDELA PLOT

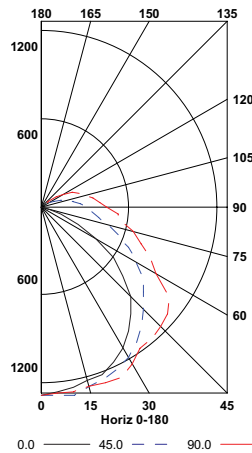

### AVG. LUMINANCE (Candela/Sq. M.)

	0.0	22.5	45.0	67.5	90.0
0	6950	6950	6950	6950	6950
30	6621	5988	5641	5575	5572
40	6291	5473	5170	5091	5241
45	6103	5055	4867	5060	5241
50	5589	4582	4639	5025	5245
55	5035	4122	4495	4911	5064
60	4053	3604	4167	4470	4504
65	3038	2933	3866	4216	4252
70	1809	2313	3605	3928	4006
75	941	1874	3224	3599	3816
80	522	1642	3058	3460	3622
85	267	1495	2954	3559	3726

RCR = Room Cavity Ratio

RC = Effective Ceiling Cavity Reflectance RW = Wall Reflectance

### DIMENSIONAL DATA

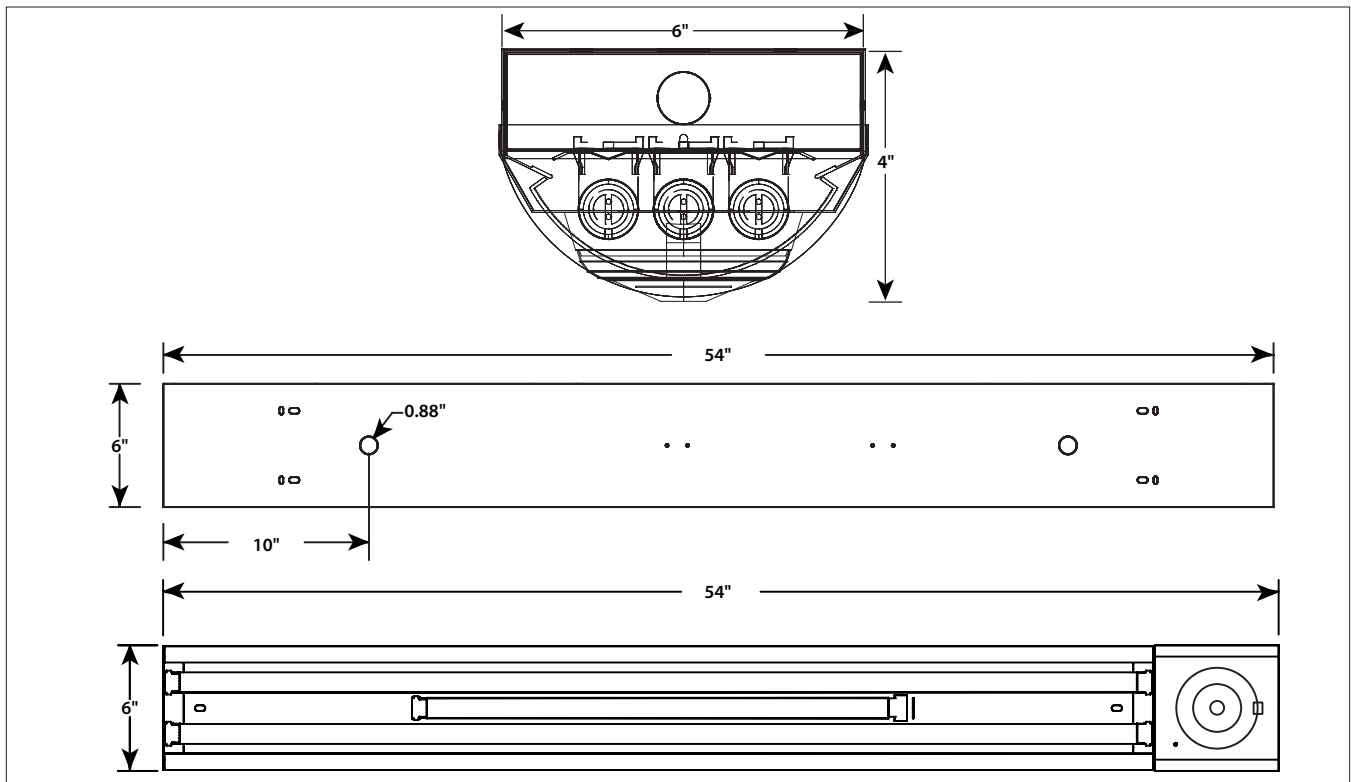

**NOTE:** All dimensions are in inches; dimensions and specifications are subject to change without notice. Please consult factory or check sample for verification.