

BRIGGS®

ABINGDON™

4231/4764/4759

Two Piece Toilet, 1.6 gpf/ 6.0 lpf

FEATURES

- Vitreous china
- Boxed rim, jetted bowl
- 12" (305 mm) rough-in
- 1.6 gpf/6.0 Lpf
- Includes color matched plastic trip lever
- Limited Lifetime Warranty
- Toilet seat sold separately

MODEL & DESCRIPTION

4759 Combination consists of:

4860 Abingdon Round front bowl
Shipping weight: 35 lb (15.9 kg)

4440 Abingdon 12" Rough-In tank
Shipping weight: 34 lb (15.4 kg)

4764 Combination consists of:

4865 Abingdon Elongated front bowl
Shipping weight: 38 lb (17.2 kg)

4440 Abingdon 12" Rough-in tank
Shipping weight: 34 lb (15.4 kg)

4231 Combination consists of:

4868 Abingdon ComfortFit ADA front bowl
Shipping weight: 43 lb (kg)

4440 Abingdon HET 12" Rough-in tank
Shipping weight: 34 lb (15.4 kg)

Optional Tanks:

4442 12" R.I. with Right Hand Flush Lever

4444 10" Rough-in Tank

4445 14" Rough-in Tank

CODES & STANDARDS

Meets or exceeds the following:

- ASME A112.19.2
- CSA B45.1
- IAPMO/cUPC 

Dimensions may vary (+) or (-) 1/4". Dimensions shown in parentheses are in millimeters: 25.4 mm = 1 inch. Note: Fixture dimensions are nominal and conform with dimension and performance requirements of ASME A112.19.2-2008/CSA B45.1-08 standards. PSI rating: 20 minimum to 80 maximum per ASME A112.19.2-2008/CSA B45.1-08 standards. Dimensions subject to change or cancellation without notice. Briggs is not responsible for the use of superceded or voided specification information.



COLORS:

- WHITE (130)
- BISCUIT (235)
- BONE(733)

SPECIFICATIONS

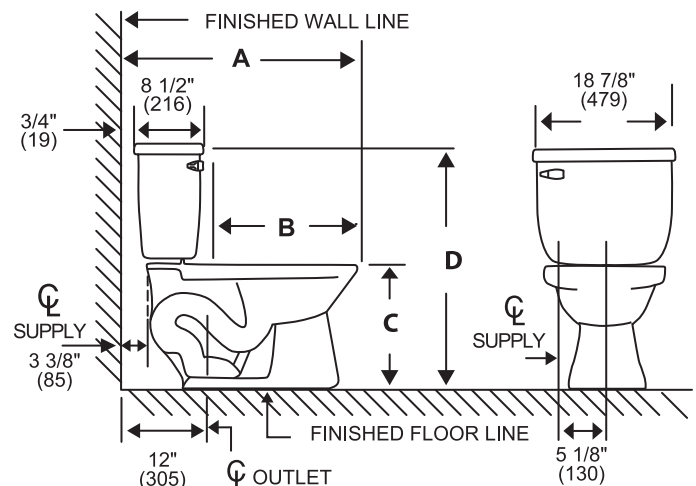

	4759	4764	4231
A	27 1/2" (699)	29 1/2" (749)	30 1/2" (775)
B	16 1/2" (419)	18 1/2" (470)	18 1/2" (470)
C	14 3/4" (375)	14 3/4" (375)	17" (432) ♿
D	29" (737)	29" (737)	31 1/2" (802)

BRIGGS®

(800) 888-4458

www.briggsplumbing.com

Conforme con:
 ASME/ANSI A 112.19.2M
 This drawing complies
 according to ASME 112
 CONFORMING WITH ASME 112
 WITH AN ADDED COMMENT
 1.4µm/0.1µm OR LESS
 THIS LABEL IS RESERVED FOR
 REMOVAL BY OCCUPANT ONLY

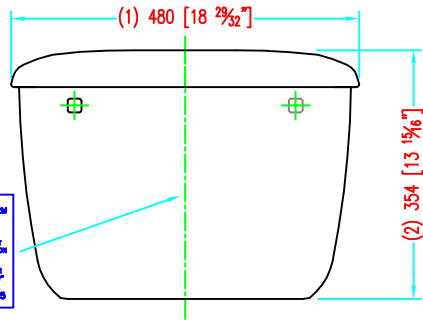

FRONT VIEW

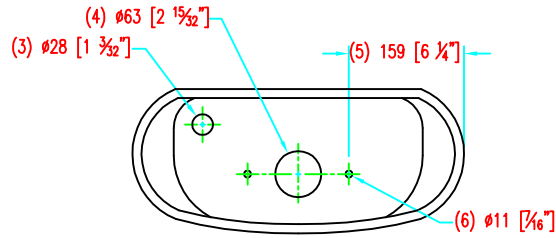

PLANT VIEW

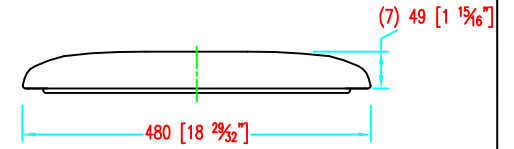

FRONT VIEW

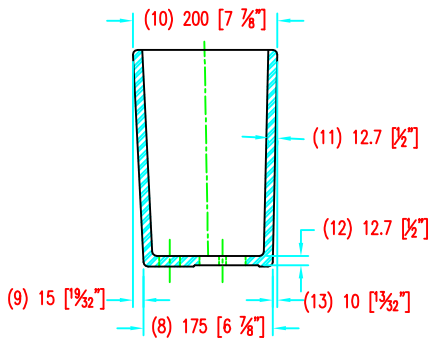

SECTION B - B

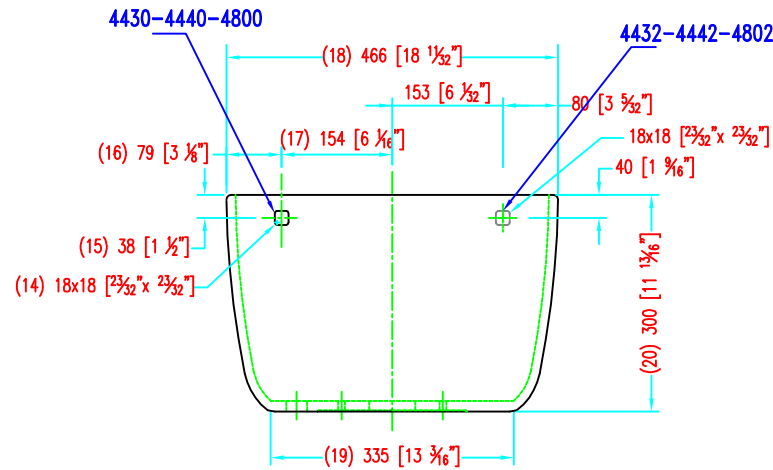

FRONT VIEW

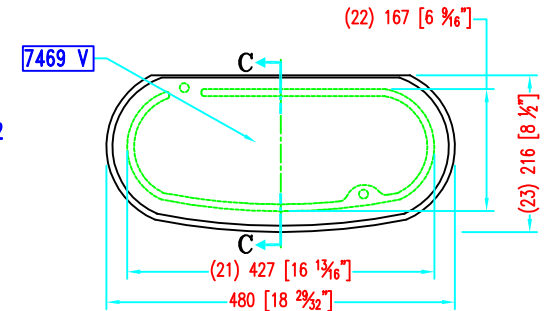

BOTTOM VIEW

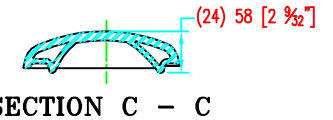

SECTION C - C

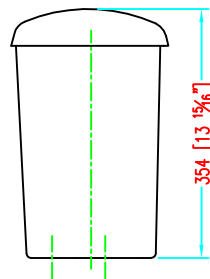

SIDE VIEW

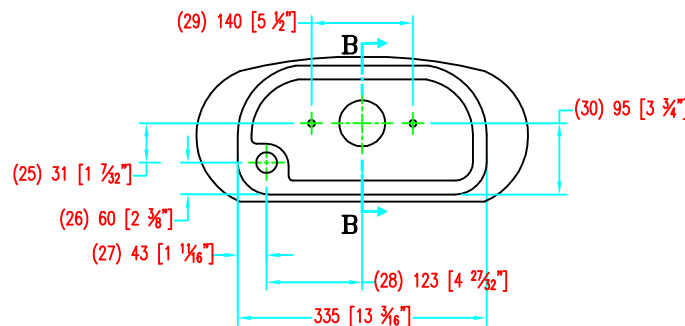

BOTTOM VIEW

MATERIAL TOLERANCE
 Vitreous China ±3% < 200 mm
 ±6mm > 200 mm

		® BRIGGS INDUSTRIES Inc. 300 EAGLE DRIVE GOOSE CREEK, SOUTH CAROLINA 29445, USA		
		PRODUCT N° 4430/4432/4440/4442/4800/4802	DESCRIPTION Altima Tank	
N°	DATE	REVISION	APP.	DATE: April 2006
				SCALE: 1:10
				DRAWN BY:
				CHECKED BY:
				APPROVED:
				DRAWING N°
Drawing of part manufactured in Venceramica				4430/4432/4440/4442/4800/4802