



X-2 HF SSB Transceiver

Technical service manual

© 1992, 1993 Codan Pty Ltd.
ACN 007 590 605
Order code 15-02047
Issue 2, October 1993

Head Office

Codan Pty Ltd
81 Graves Street
Newton
SOUTH AUSTRALIA 5074

Telephone
National 08 336 0311
International +61 8 336 0311
Facsimile 08 337 6090

International Marketing Offices

Australia, Pacific and South East Asia

Codan Pty Ltd
Suite 24, 818 Pittwater Road
Dee Why
New South Wales
AUSTRALIA 2099

Telephone
National 02 971 2233
International +61 2 971 2233
Facsimile 02 982 1117
Telex 22631

Africa, Europe and The Middle East

Codan (U.K.) Ltd
6 Grove Park
Mill Lane
Alton, Hampshire GU34 2QG
UNITED KINGDOM

Telephone
National 0420 80121
International +44 420 80121
Facsimile 0420 541098
Telex 858355

North and South America

Codan Pty Ltd
Suite 101
8011 Leslie Road
Richmond BC V6X 7E4
CANADA

Telephone
National 604 270 8332
International +1 604 270 8332
Facsimile 604 270 4401

Table of Contents

1 Introduction	1-1
1.1 Purpose.....	1-1
1.2 How this manual is organised	1-1
1.3 Conventions	1-2
1.4 Related Documents	1-2
1.5 Overview	1-2
1.6 Specifications.....	1-3
1.6.1 General Specifications.....	1-3
1.6.2 Receiver Specifications	1-5
1.6.3 Transmitter Specifications.....	1-6
2 Brief Description	2-1
2.1 General	2-1
2.2 Control and Switching.....	2-2
2.3 Synthesiser.....	2-2
2.4 Receive Path	2-3
2.5 Transmit Path.....	2-4
3 Operating Instructions	3-1
4 Technical Description	4-1
4.1 Control and Supply Voltages.....	4-2
4.1.1 Power.....	4-2
4.1.2 Supply Voltages	4-2
4.1.3 Receive/Transmit Switching.....	4-3
4.2 Receiver.....	4-4
4.2.1 Input Filters	4-4
4.2.2 First Mixer.....	4-4
4.2.3 45 MHz Roofing Filter.....	4-4
4.2.4 Second Mixer	4-4
4.2.5 Noise Limiter.....	4-5
4.2.6 455 kHz Filter and IF Amplifier	4-5
4.2.7 Automatic Gain Control.....	4-6
4.2.8 Mute.....	4-7
4.2.9 Volume Control and Audio Amplifier	4-8

4.3	Transmitter Exciter	4-8
	4.3.1 Microphone Compressor.....	4-8
	4.3.2 Modulator	4-9
	4.3.3 455 kHz Filter and First Mixer.....	4-9
	4.3.4 45 MHz Roofing Filter.....	4-9
	4.3.5 Second Mixer and Exciter Output Filter.....	4-9
4.4	Local Oscillators	4-10
	4.4.1 Introduction.....	4-10
	4.4.2 VCO1 and PLL	4-10
	4.4.3 VCO2 and PLL	4-11
	4.4.4 455 kHz Local Oscillator	4-12
	4.4.5 Clarifier	4-12
4.5	Micro and Peripherals	4-13
	4.5.1 Microcontroller.....	4-13
	4.5.2 I ² C Bus	4-13
	4.5.3 PA Control Bus	4-13
	4.5.4 Front Panel Controls.....	4-14
	4.5.5 Tune.....	4-15
	4.5.6 Tone Generation.....	4-15
	4.5.7 A/D Inputs.....	4-15
	4.5.8 Microcontroller Reset	4-16
4.6	PA and Filters	4-16
	4.6.1 Gain Control Stage.....	4-17
	4.6.2 Predriver Stages	4-17
	4.6.3 Driver Stage	4-17
	4.6.4 Output Stage and Bias Regulator.....	4-18
	4.6.5 Output Filters and Antenna 1 and 2 Select	4-18
	4.6.6 ALC Control	4-18
5	Maintenance.....	5-1
5.1	Introduction	5-1
5.2	General	5-1
	5.2.1 CMOS Devices.....	5-1
	5.2.2 Circuit Boards	5-2
	5.2.3 Transmitter Precautions	5-3
	5.2.4 Probe Precautions.....	5-4
5.3	Fault Diagnosis	5-4
	5.3.1 General.....	5-4
	5.3.2 Voltage measurements	5-5
	5.3.3 No Reception	5-6

5.3.4	Transmitter Failure	5-7
5.3.5	Unlocked Synthesiser.....	5-7
5.3.6	PA Failure	5-8
5.4	Dismantling and Assembling.....	5-8
5.4.1.	General.....	5-8
5.4.2	Top and Bottom Covers	5-9
5.4.3	Rx/Exciter & Control PCB	5-9
5.4.4	Front Panel PCB.....	5-9
5.4.5	PA and Filter Assembly.....	5-10
5.4.6	Replacement of PA Transistors	5-11
6	Channel Additions.....	6-1
7	Adjustments	7-1
7.1	Introduction	7-1
7.2	Test Equipment Required.....	7-1
7.3	Voltage Regulators	7-1
7.4	Crystal Oven	7-2
7.5	Test Mode	7-2
7.6	VCO Checks and Adjustments	7-4
7.6.1	VCO1 Check.....	7-4
7.6.2	VCO2 Check.....	7-4
7.6.3	VCO2 Adjust.....	7-5
7.7	45 MHz Filter Alignment.....	7-5
7.7.1	Alignment - Method 1.....	7-6
7.7.2	Alignment - Method 2.....	7-7
7.8	455 kHz IF and N/L Alignment	7-7
7.9	Frequency Adjustment.....	7-8
7.9.1	Frequency Adjust USB	7-8
7.9.2	Frequency Adjust LSB.....	7-9
7.10	Mute Adjustment.....	7-9
7.11	PA Adjustments.....	7-10
7.11.1	Driver Bias	7-10
7.11.2	PA Bias	7-10
7.11.3	Output Power	7-11
7.11.4	Intermodulation	7-12
7.12	Receiver Performance Checks.....	7-13
7.12.1	Sensitivity and S+N/N ratio	7-13
7.12.2	AGC Check.....	7-13
7.12.3	Audio Output	7-13

7.12.4	Selectivity (USB operation)	7-13
7.12.5	Clarifier Operation	7-14
7.12.6	Noise Limiter Operation	7-14
7.13	Transmitter Performance Checks	7-14
7.13.1	Frequency Check	7-14
7.13.2	ALC	7-15
7.13.3	Power Output and Intermodulation	7-15
7.13.4	Emergency Call	7-15
8	Appendices	8-1
	Appendix A: Connectors	8-1
A.1	Microphone	8-1
A.2	External Loudspeaker	8-1
A.3	Antenna Control	8-2
A.4	Programming Cable	8-2
A.5	Cloning Cable	8-2
	Appendix B: Parts Lists	8-3
B.1	General Information	8-3
B.2	Ordering Information	8-4
B.3	Component Substitution	8-4
B.4	Parts Lists	8-4
	Appendix C: Engineering Drawings	8-23
	Appendix D: Glossary of Terms	8-25
D.1	Abbreviations	8-25
D.2	Abbreviations of Units	8-26
D.3	Abbreviations of Unit Multiples	8-27

List of figures

Figure	Description	Page No
2.1	X-2 PCB Block Diagram	2-1
7.1	Ripple Response	7-6

List of tables

Table	Description	Page No
2.1	Drawing Reference	2-1
3.1	Audible Warning Tones	3-2
4.1	Drawing Reference	4-1
4.2	Rx/Exciter PCB Supply Voltages	4-2
4.3	PA PCB Supply Voltages	4-2
5.1	Peak to Peak Voltages	5-8
7.1	USB/LSB Test Frequencies and Functions	7-3
7.2	Power Output PEP vs Measuring Instrument	7-11
A.1	Microphone Connector Pin Function	8-1
A.2	External Loudspeaker Connector Pin Function	8-1
A.3	Antenna Control Connector Pin Function	8-2
A.4	Programming Cable Connector Pin Function	8-2
A.5	Cloning Cable Connector Pin Function	8-2
B.1	Resistor and Capacitor Abbreviations	8-3
B.2	Parts List Index	8-4
C.1	List of Drawings	8-24
D.1	Abbreviations	8-26
D.2	Abbreviations of Units	8-27
D.3	Abbreviations of Unit Multiples	8-28

1

Introduction

1.1 Purpose

The purpose of this manual is to provide a technical description, details and drawings about the X-2 transceiver for the technician to understand the:

- function
- technical operation
- fault diagnosis
- dismantling and assembly
- setup and adjustment procedures

1.2 How this manual is organised

The X-2 Technical Service Manual is organised as follows:

Chapter 1	An overview of the features of the X-2 transceiver including specifications.
Chapter 2	A brief description of the X-2 transceiver with a general description of the major circuit functions for the control, reception and transmission of signals.
Chapter 3	Operating instructions for the X-2 transceiver.
Chapter 4	A more detailed technical description of the operation and circuit function of the X-2 transceiver. Read this with the associated technical drawings found in the appendices.
Chapter 5	Maintenance, general cautions and warnings, fault diagnosis procedures associated with the maintenance of the X-2 transceiver.
Chapter 6	Programming procedures for channel additions.
Chapter 7	Adjustments, checks and alignments to the X-2 Transceiver detailing required test equipment.
Chapter 8	Comprises four appendices. Connector tables, parts lists, engineering drawings and glossaries.

1.3 Conventions

The X-2 transceiver is type approved in Australia as the 9105 transceiver. All type approval documentation refers to it as the 9105. Throughout this manual the transceiver is referred to as the X-2.

1.4 Related Documents

If there is a need to program the X-2, make reference to the XP programming guide. This guide is available as a separate document, Codan Part No:15-04035.

1.5 Overview

The X-2 is a 10 channel, high frequency single sideband (HF SSB) transceiver suitable for use in fixed station or mobile applications.

The X-2 can be factory set or dealer programmed using the XP programming system to select:

- operating frequencies
- mode of operation
- emergency calling
- one of two antenna output sockets.

This programming feature eliminates the need for crystals and discreet channelling/customising components. Because operation on lower sideband (LSB), upper sideband (USB) or Emergency Call (Royal Flying Doctor Service RFDS - only in Australia) is software programmable, there is no need for factory fitted hardware options.

Different audio tones indicate operating conditions or system faults such as:

- excessive VSWR
- tune complete or fail
- low or high supply voltage
- channel not programmed.

Where two channel networks are used, two separate antenna output sockets on the rear panel allow the use of:

- individually tuned half-wave dipole base station antennas
- mobile whips.

This eliminates the need for antenna selectors or coaxial switches.

Users can clone the programmed information contained in the X-2 to another transceiver by using the microphone socket. XP software is not required for cloning.

1.6 Specifications

This section of the manual provides specifications for the X-2 transceiver in the following categories:

- General Specifications
- Receiver Specifications
- Transmitter Specifications

The specification figures listed are the minimum standard for the X-2 transceiver and production models will equal or exceed these figures. Where relevant, acceptance limits are shown in brackets.

Unless otherwise specified, all measurements have been made using 13.6 V DC, with 50 Ω source and load resistances at an ambient temperature of 25°C.

1.6.1 General Specifications

Frequency Range	2 to 18 MHz.			
Channel Capacity	10 channels. Any combination of single or dual frequency simplex.			
Frequency Generation	Frequency synthesiser with 10 Hz resolution: controlled by plug-in EEPROM.			
Operating Modes	Single sideband (J3E). Programmable USB, LSB or front panel switched.			
Frequency Stability	<table> <tr> <td>USB: $\pm 2(3)$ppm</td> <td rowspan="2">} -10°C to +60°C</td> </tr> <tr> <td>LSB: $\pm 2(3)$ppm +10 Hz)</td> </tr> </table> <p>Long term ageing 1ppm per year. Crystal reference oven warm up time 1 minute.</p>	USB: $\pm 2(3)$ ppm	} -10°C to +60°C	LSB: $\pm 2(3)$ ppm +10 Hz)
USB: $\pm 2(3)$ ppm	} -10°C to +60°C			
LSB: $\pm 2(3)$ ppm +10 Hz)				
Programming	Frequencies and options are programmed via the microphone socket and 3-wire RS232 interface using XP programming software and an IBM compatible PC.			
Cloning	Channel frequencies and options can be copied from one transceiver to another via the microphone socket.			
Controls	Power ON/OFF and Volume. Channel select. Clarifier. Mode USB/LSB. Mute ON/OFF/Tune. Emergency Call: RFDS 880/1320 Hz. (Australia only)			

Indicators	Power On/Transmit.						
Connectors:							
Front	Microphone/Handset.						
Rear	RF - UHF connectors: Qty 2 (programmable). Antenna Control. Extension Loudspeaker.						
RF Input/Output impedance	50 Ω nominal.						
Supply Voltage	12 V DC nominal, negative earth. Normal operating range 10.5 to 15 V. Maximum operating range 9 to 16 V approx. Reverse polarity protection.						
Supply Current	Receive : no signal 360 mA. Transmit: refer to Transmit Specifications.						
Environment	<table> <tr> <td>Ambient Temp.</td> <td>Relative Humidity</td> </tr> <tr> <td>-10°C to +30°C</td> <td>95%</td> </tr> <tr> <td>+30°C to +60°C</td> <td>From 95% at +30°C to 30% at +60°C</td> </tr> </table> <p>Derate upper ambient temperature by 1°C per 330 m above sea level.</p>	Ambient Temp.	Relative Humidity	-10°C to +30°C	95%	+30°C to +60°C	From 95% at +30°C to 30% at +60°C
Ambient Temp.	Relative Humidity						
-10°C to +30°C	95%						
+30°C to +60°C	From 95% at +30°C to 30% at +60°C						
Cooling	Convection.						
Size and Weight	<p>Transceiver only: 230 mm W x 75 mm H x 290 mm D 2.5 kg</p> <p>With mounting cradle: 250 mm W x 90 mm H x 290 mm D 3.0 kg</p> <p>Depth measurements include rear connectors/cables.</p>						

1.6.2 Receiver Specifications

Type	Dual conversion, superheterodyne.
IF Frequencies	45 MHz and 455 kHz.
Sensitivity	0.3(0.4) μ V PD -117(-115) dBm for 10 dB SINAD with > 50 mW audio output.
Input Protection	Will withstand 50 V RF from 50 Ω .
Selectivity	Greater than 70(65) dB at -1 kHz and +4 kHz reference SCF USB. Pass Band -6(-8) dB 300 to 2700 Hz Ripple 2(4) dB pp 500 to 2500 Hz
Desensitisation	10 dB SINAD reduced to 7 dB SINAD. -1 and +4 kHz (ref SCF) 65(60) dB \pm 10 kHz 85(80) dB \pm 50 kHz 100(95) dB
Image Rejection	Better than 90(80) dB.
Spurious Responses	Better than 90(70) dB. Self Generated Signals > 0.3 μ V PD: 3652, 5478, 7304, 9130, 10956, 14608 kHz.
Cross Modulation	A signal 85(80) dB above a signal producing 10 dB SINAD, modulated 30% and removed at least 20 kHz from the wanted signal will produce an increase in receiver noise of less than 3 dB.
Blocking	As for desensitisation.
Intermodulation	To produce a third order intermodulation product equivalent to a wanted signal producing 10 dB SINAD, two unwanted signals greater than 30 kHz removed from the wanted signal must have a level greater than 82(80) dB above the wanted signal. Third order intercept +7(4) dBm, not affected by AGC.
AGC	Less than 6 dB variation in output for input variation between 1.5(2.5) μ V and 100 mV PD. Fast attack, slow release.
AF Power and Distortion	2.5 W into 8 Ω 5% THD 5.0 W into 4 Ω 5% THD 8.0 W into 2 Ω 5% THD.
Clarifier	\pm 50 Hz up to 5 MHz \pm 10 ppm above 5 MHz Clarifier is automatically reset to mid-frequency with channel change.

1.6.3 Transmitter Specifications

Type	All solid state.
Power Output	100 W PEP \pm 0.5 dB may be internally set to any output between 125 and 25 W PEP. CW or single tone approx. 60% of PEP. (Average ALC control).
Duty Cycle	100% normal speech.
Supply Current	2-tone/CW 8 to 12 A Average speech 6 A Average speech for battery life calculations.
Protection	Safe under all load conditions by limiting reflected power to 10 W PEP and limiting PA transistor collector voltage swing. Thermal protection against excessive heatsink temperature.
AF Response	Overall response of microphone and transmitter rises approximately 6 dB/octave 300-2700 Hz. Electrical input -6(8) dB, 300-2700 Hz. Ripple 2(4) dB pp, 500-2500 Hz.
Spurious and Harmonic Emissions	55(48) dB below PEP.
Carrier Suppression	60(50) dB below PEP.
Unwanted Sideband	50(45) dB below PEP (400 Hz). 70(65) dB below PEP (1 kHz).
Intermodulation (2 tone test)	100 W 30(26) dB below each tone. 36(32) dB below PEP. 125 W 27(26) dB below each tone. 33(32) dB below PEP.
ALC	A 10 dB increase in signal input above compression threshold produces less than 0.5 dB increase in power output. Maximum ALC range greater than 30 dB. ALC attack time approximately 1 ms.
Residual Noise	65(55) dB below PEP of selected channel.
Microphone	Dynamic type with push-to-talk switch fitted in the case.



2

Brief Description

This section of the manual provides a brief description of the major components and circuit functions of the X-2 transceiver as follows:

- Control and switching functions
- Synthesizer operation
- Receive path
- Transmit path

For an in-depth review of these functions refer to Chapter 4 "Technical Description".

2.1 General

Read this description of the X-2 transceiver with the circuit drawing shown in Table 2.1.

Title	Circuit Diagram
X-2 Block Diagram	03-00876

Table 2.1: Drawing reference

The X-2 transceiver is a double conversion superheterodyne receiver. It uses 45 MHz and 455 kHz IF frequencies for the double conversion process. The 45 MHz roofing filter and the 455 kHz sideband filter are common to the transmit and receive audio paths.

The transceiver can be programmed with channels for either single or dual frequency simplex operation, and uses the double conversion **Error!** **Bookmark not defined.** process when transmitting or receiving.

The X-2's circuits and functions are located on three major PCBs as shown in Figure 2.1.

- Front panel PCB and panel controls
- Rx/Exciter & Control Circuit PCB consisting of:
 - RF and Dual synthesizer circuits
 - 455 kHz IF and audio circuits
 - Microprocessor and peripheral circuits
- PA and Filter PCB.

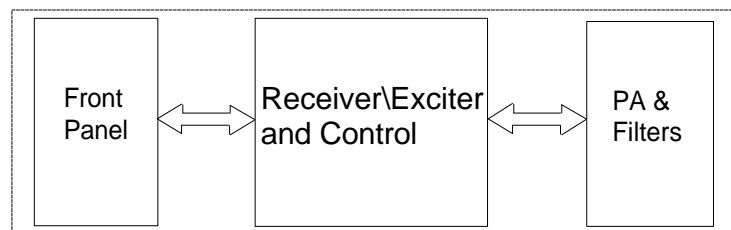

Figure 2.1: X-2 PCB Block Diagram

The main elements of the X-2 can be divided into the control and switching functions, the synthesizers used to produce the oscillator frequencies and the signal paths taken in receive and transmit modes.

Circuit elements and functions common to both the transmit and receive paths are the:

- 45 MHz roofing filter
- 455 kHz sideband filter
- local oscillators VCO1 and VCO2

2.2 Control and Switching

The switching and control voltages determine the path taken by the transmit or receive signals through the transceiver.

Most of the transceiver functions are controlled by microcontroller IC403. Channel frequencies and options are programmed via the microcontroller to the Electrical Erasable Programmable Read Only Memory (EEPROM), IC404. All other transceiver functions are pre-programmed in the microcontroller's internal Read Only Memory (ROM).

The power on/off and volume controls are hardware functions and not controlled by the microcontroller. The on/off switch is part of the volume control and directly energises a power-on relay. A series diode provides reverse polarity protection.

The volume control in the audio signal path connects the preamplifier (after the demodulator) and the audio amplifier to drive the loudspeaker.

2.3 Synthesizer

The X-2 transceiver uses single loop synthesizers. The main synthesizer (VCO1) generates an oscillator frequency of 47 MHz to 63 MHz i.e. 2 MHz to 18 MHz plus 45 MHz, in 2 kHz steps.

The vernier synthesizer (VCO2) generates oscillator frequencies of 44.5435 MHz to 44.5455 MHz in 10 Hz steps.

The microcontroller IC controls the synthesizers by loading serial data into both synthesizers. The data varies according to the required channel frequency programmed into the memory.

When the upper sideband is selected, the X-2 uses one main reference oscillator of 7304 kHz to produce 456.5 kHz (7304 kHz divided by 16). If lower sideband is needed, a second crystal of 1814 kHz is used to provide 453.5 kHz (1814 kHz divided by 4).

2.4 Receive Path

PA and Filter PCB

The received signal from the antenna passes through a PA low-pass filter to the transmit/receive relay and broadcast filter on the PA PCB to the receiver input on the main PCB.

Rx/Exciter & Control PCB

From the receive input, the signal is fed via a second 20 MHz low-pass filter to the input of the first balanced mixer. Here it mixes with the local oscillator VCO1 and converts to 45 MHz.

A 15 kHz roofing filter filters this 45 MHz signal before being applied to the second balanced mixer. The signal mixes with a second local oscillator VCO2 producing an IF signal centred on 455 kHz.

The output of the second mixer divides into two paths:

- the main path passes through a noise gate to a 2.5 kHz sideband filter where only the wanted sideband passes to the high gain AGC controlled IF amplifier.
- the second path passes the signal through an amplifier which detects noise and controls the noise gate to remove impulse noise such as car ignition from the 455 kHz signal.

The amplified 455 kHz signal is demodulated to produce an audio signal and amplified. The amplified audio signal operates an AGC circuit. This controls the IF amplifier gain to prevent overloading when receiving strong signals. It is also used to maintain a constant audio output with changing input signals.

After amplification the signal passes through a mute that removes the receiver noise from the speaker when enabled. When speech is detected, the gate in the audio line closes to allow the signal to be heard. The signal feeds the volume control on the Front Panel PCB.

Front Panel PCB

The signal from the volume control is applied to a power amplifier IC2 to drive the transceiver's loudspeaker.

2.5 Transmit Path

Rx/Exciter PCB

The microphone amplifier/compressor IC303/306, amplifies and levels the audio signal from the microphone and drives a balanced modulator IC301.

When mixed with the local oscillator, the double sideband output of the modulator feeds a 2.5 kHz sideband filter centred on 455 kHz, passing only the wanted sideband to the first mixer IC9. Here it mixes with the local oscillator VCO2 to produce an IF signal of 45 MHz.

The 15 kHz wide roofing filter centred at 45 MHz filters the transmit signal to remove unwanted mixed signals before it feeds the second mixer.

At the second mixer, the signal mixes with the oscillator VCO1 producing the required channel frequency (2 MHz to 18 MHz) and passes through a 20 MHz low pass filter to the Power Amplifier & Filter PCB (PA PCB).

PA and Filter PCB

The PA assembly amplifies the signal, passes it on to the transmit/receive relay, and then to the selected band filter. At the filter output it continues to the VSWR detector. The detector monitors the forward and reflected power and controls the power output of the transmitter. If a high VSWR is detected, the power output reduces to protect the power amplifier.

A coaxial cable connects the signal to the appropriate antenna for transmission.



3 Operating Instructions

This section of the manual describes how to operate the X-2 Transceiver in both normal and RFDS Emergency Call (Australia only) modes. Table 3.1 provides an explanation of the meaning of audible tones. To operate the X-2:

1. Switch the transceiver on by turning the **Volume** control clockwise until the indicator lamp lights.
2. Select the required **Channel** and **USB** or **LSB** mode.
3. If using a broadband or dipole antenna go to step 5.
4. After selecting the required channel:
 - (i) Where a multi-frequency tapped whip is used, select the correct tap position for the frequency in use.
 - (ii) Where an automatic antenna tuner is used, select **Tune** for approximately one second and ensure the "tune complete", double high beep is heard.
 - (iii) Where a manual antenna tuner is being used, set the tuner controls to the logging scale positions. Before transmitting operate the **Tune** switch and adjust the **Tune** control on the front panel for maximum meter reading.
5. With the **Mute** switch in the **Off** position, set the **Volume** control to a comfortable listening level. The mute function removes background noise when no signals are present and should be switched **Off** to prevent occasional loss of syllables when communicating in the presence of weak signals.
6. Adjust the **Clarifier** to obtain a better speech quality if necessary.
7. Listen before transmitting to ensure that the selected **Channel** is free of traffic.
8. Hold the **Microphone** side-on, close to the mouth. Press the **Transmit** button and speak clearly.
9. When transmitting, the **Indicator** light will flicker. **Tune** will cause the **Indicator** to light continuously.
10. Audible tones are provided to inform the operator of equipment status or provide an operating error warning as shown in Table 3.1.

BEEPS				CONTINUOUS	
Low Tone		High Tone		Low Tone	High Tone
Single	Transmit inhibited			Channel unavailable	High supply voltage
Double	Tune Fail (check antenna)	Double	Tune complete		
Slow repetitive	Low supply voltage	Repetitive	Channel not programmed		
Fast repetitive	PTT time out				

Table 3.1: Audible Warning Tones

11. If making an RFDS Emergency Call (Australia only) carry out the steps as outlined in 1 to 5 and proceed as follows:
 - (i) Ensure a local RFDS channel has been selected - on other channels the call will not be transmitted.
 - (ii) Operate **Emgcy Call** switch for at least 15 seconds then wait for a reply before transmitting. Unattended RFDS base stations will transmit a tone within 90 seconds if the call has been received.

 **CAUTION**

1. *Do not obstruct the free flow of air through the transceiver rear fins.*
2. *If using two antennas, connect them to the correct antenna sockets for the frequency being used.*



4

Technical Description

This section of the manual contains a technical description of the X-2 transceiver and should be read together with the drawings shown in Table 4.1.

Description	Circuit Diagram	PCB Assembly
Rx/Exciter & Control	04-02907 (3 sheets)	08-04840
-RF and Dual Synthesizer	Sheet 1	
-455 kHz IF and Audio	Sheet 2	
-Micro and Peripherals	Sheet 3	
PA and Filter	04-02908	08-04841
Front Panel	04-02909	08-04842

Table 4.1: Drawing reference Directory

Circuit components on the Rx/Exciter PCB are numbered according to the following system:

- Sheet 1: 1 to 299
- Sheet 2: 301 to 399
- Sheet 3: 401 to 499

A prompt to use a particular drawing will appear as a symbol in the text.

For example:

 04-02907 sheet 1 indicates that you should use sheet 1 of drawing number 04-02907.

As an additional help a general location guide has been provided to indicate where to find certain circuit elements described in the text.

For example:

IC302^[D5] can be found in the vicinity of row D and column 5.

4.1 Control and Supply Voltages

All switching, except power on, is controlled either directly or indirectly by the microcontroller located on the Rx/Exciter PCB.

4.1.1 Power

☞04-02909

When contact S1^[D2] (part of volume control assembly) on the front panel is closed, ☞04-02908 a ground is applied to relay K8^[C10] on the PA assembly via interconnecting cables between the Front panel, Rx/Exciter, and the PA assembly. K8 relay energises and closes contacts K8-1^[D11], applying the DC supply to the Transceiver.

Diode D5 in series with K8 prevents the relay from energising should the supply be accidentally connected in reverse.

4.1.2 Supply Voltages

The supply voltages used on the Rx/Exciter PCB are shown in Table 4.2.

Supply	Description	Regulator
'A' rail	unregulated battery supply	
'B' rail	+10 V regulated supply	IC401
+5VA	5 V regulated supply	IC3
+5VB	5 V regulated supply	IC402

Table 4.2: Rx/Exciter PCB Supply Voltages

The supply voltages used on the PA PCB are shown in Table 4.3.

Supply	Description	Regulator
'A' rail	unregulated battery supply	
+5V	5 V regulated supply selected in transmit only	IC2
+5V	5 V supply to IC1	V1

Table 4.3: PA PCB Supply Voltages

4.1.3 Receive/Transmit Switching

☞04-02907 sheet 3

The microcontroller IC403^[F6] controls whether the path through the transceiver is set up for receiving or transmitting. Serial data (I²C bus) from the microcontroller feeds a 16 bit output expander IC405^[E8] on the Rx/Exciter PCB.

☞04-02907 sheet 1

Output pin 15, which is the transmit/receive select line, connects to cascaded NAND gates IC7/D^[A6] and IC7/C to operate the appropriate mixers via switching transistors in the receive and transmit modes.

Receive Mode

In the receive mode Pin 15 of IC405 is high (+10 V). This sets output pin 11 of IC7/D low and forward bias transistors V1^[B2] and V8^[B7]. These supply the +10 V to switch on the receive mixers IC1 and IC8 respectively.

Transmit Mode

In the transmit mode pin 15 of IC405 is low (0 V). This sets output pin 11 of IC7/D high, switching off the receive mixers. Because pin 11 is connected to a second NAND gate (pin 9), output pin 10 is now low and forward biases V2^[B4] and V9^[B8]. These switches supply the +10 V to switch on the transmit mixers IC2^[D3] and IC9^[D7].

Three additional functions of switch V9 in the transmit mode are:

- DC is applied from the collector via D9^[C9] and R54 to pin 7 of IC13. This sets the noise limiter IF amplifier to minimum gain and inhibits the noise limiter from operating in the transmit mode.
- The collector is connected to analogue switch IC305/B^[C9] pin 5. With a high on pin 5 of IC305/B the analogue switch is closed applying a ground to differential input pin 5 of AGC amplifier IC307/B^[C8]. This sets the AGC to 0 V, switching off the receive 455 kHz IF amplifier V301/V302^[B5], avoiding the necessity to inhibit the demodulator IC302 in transmit mode.
- V9 enables the transmit modulator IC301^[D3] by providing a DC bias current via R312 to pin 5.

☞04-02908

Serial data from the microcontroller is also applied to IC1^[C4] on the PA assembly. When transmit is selected, a ground on pin 11 energises the transmit/receive relay K7^[D8]. This completes the path from the PA output via the filters to the antenna socket.

4.2 Receiver

4.2.1 Input Filters

04-02908

The receiver input signal passes through the:

- selected PA low-pass filter
- transmit/receive relay K7
- 2 MHz high-pass broadcast filter to the Rx/Exciter & Control PCB.

4.2.2 First Mixer

04-02907 Sheet 1

The receive signal is applied to connector P1^[A1] pins 1 and 2 on the Rx/Exciter & Control PCB. It then passes through a 20 MHz low-pass filter and transformer T1 to the input pins 12 and 13 of the first mixer IC1^[C3].

Mixer IC1 is a combined amplifier/balanced mixer with a gain of approximately 20 dB. The received signal mixes with the output of Voltage Controlled Oscillator VCO1 operating between a frequency of 47 MHz and 63 MHz, producing a balanced IF output centred at 45 MHz at pins 3 and 14.

4.2.3 45 MHz Roofing Filter

The 45 MHz IF signal is filtered through a 15 kHz roofing filter consisting of T3, Z1, L10, Z2 and T4. This removes unwanted products produced by the mixer. The filter output is applied to the balanced input pins 12 and 13 of the second mixer IC8^[C7].

4.2.4 Second Mixer

Mixer IC8 is a combined amplifier/balanced mixer and identical to mixer IC1. The 45 MHz signal mixes with the output of a second Voltage Controlled Oscillator VCO2^[E7] operating between 44.5435 MHz and 44.5455 MHz to produce a second IF centred at 455 kHz.

4.2.5 Noise Limiter

The 455 kHz output at pins 3 and 14 of IC8 is applied via C79, R52, C80, and R53 to the balanced input of high gain amplifier IC13^[C9] pins 4 and 6.

The balanced output at pins 1 and 8, connect to a tuned transformer T6 (455 kHz) which sends its output to the base of the active rectifier V11. Noise bursts produce positive going pulses at the collector of V11 and trigger via V12 the monostable flip-flop IC7/A and IC7/B. The pulse width is determined by C86 and R60 (nominally 250 μ s).

The outputs of the flip-flop pins 3 and 4 produce complementary pulses that are connected to FET gates V14 and V15^[D11] and gate out the noise bursts from the 455 kHz signal.

With V14 on and V15 off, the IF signal passes to the sideband filter.

When a noise burst is present, V14 switches off and V15 switches on, blocking the IF signal for the period of the gate pulse.

The average DC component of V11 collector current serves as an automatic gain control to IC13, and flows via R57^[C10] to pin 5. This ensures that only the noise burst signals trigger the monostable. C82 and R56 set the AGC decay time constant.

4.2.6 455 kHz Filter and IF Amplifier

04-02907 Sheet 2

A 2.5 kHz ceramic filter Z301^[B2] receives the IF signal from the noise limiter and removes the unwanted sideband signal and other unwanted products generated by the second mixer. The wanted sideband centred at 455 kHz passes from the filter to a two stage gain controlled amplifier consisting of V301^[B4] and V302 and associated components.

The IF amplifier is broadly tuned to 455 kHz by the tuned circuits L301/C304 and L302/C308. The output of the IF amplifier (drain of V302) passes via coupling capacitor C310^[B6] to the demodulator IC302 pin 1.

The 455 kHz signal converts to audio when mixed with the local oscillator in the double balanced mixer IC302. The local oscillator is set to 456.5 kHz for USB conversion and 453.5 kHz for LSB.

Note: Local oscillators VCO1 and VCO2 shift by a total of 3 kHz when switching from USB to LSB. This enables filter Z301 to be used for either sideband.

4.2.7 Automatic Gain Control

To increase the dynamic range of the receiver and to maintain an almost constant audio output for large variation of input levels, an automatic gain control (AGC) operates on the two stage 455 kHz IF amplifier.

The demodulated output from pin 6 of IC302 is applied to amplifier IC303/A^[D7] (set to a gain of 3). At its output (pin 1) the audio connects to a full wave peak rectifier circuit consisting of:

- D305^[B8] to rectify the positive component of the audio
- inverter IC307/A and D304 to rectify the negative component of the audio.

Both diode cathodes are ORed and charge capacitor C330 via R345 to the peak audio level (less the forward diode drop of D304 and D305).

The DC across C330 is applied to one input of the differential DC amplifier IC307/B (pin 6). The second input (pin 5) is connected to a reference voltage of 5.2 V set by divider network R350, D306, R351 and R352.

No Signal Conditions

Under no signal conditions, the DC level at the output of IC307/B is set by the reference voltage (5.2 V). This is then applied to gate 2 of both FETs V301 and V302 setting the IF amplifier to maximum gain.

With Signal Conditions

When the receive signal is of sufficient level to cause the peak audio to charge C330 above the reference of 5.2 V (AGC threshold), the output of the DC amplifier IC307/B falls. Gate 2 voltage subsequently drops to the two FETs causing the IF amplifier gain to fall.

The high loop gain of the AGC control network causes any signal above AGC threshold (about 3 μ V EMF) to reduce the IF amplifier gain to a level required to maintain an almost constant audio output.

The first IF stage (V301) has an additional gain control applied to gate 1. This consists of V305^[C4] and associated resistive components. Under normal signal levels V301 remains saturated by the forward bias applied from the AGC line via R369^[C4] and gate 1 voltage is determined by the resistor divider R302 and R303 (1.8 V).

When the receive signal increases to a level that causes the AGC control voltage to drop to about 2 V, V305 comes out of saturation allowing gate 1 voltage to commence rising. This increases the dynamic gain control of the first stage and prevents overloading at very high signal levels.

The AGC fast attack time is set by the time constant of R345/C330^[C8] and the slow decay time by R347/C330.

4.2.8 Mute

Squaring Amplifier

The audio at the output of IC303/A^[D7] (pin 1) is connected to the input of IC308/A^[E7] which operates a squaring amplifier. The squared output from pin 2 charges C333 via D307^[D8] during the negative excursions and the charge is transferred to C334^[F8] by V304 during the positive excursions. The resultant DC voltage on C334 is proportional to the frequency of the audio.

Low Pass Filter

IC309/B^[E9] and its associated components function as a low-pass filter with a cut-off frequency of approximately 10 Hz. The output from IC309/B is a DC voltage varying at the syllabic rate of the received speech.

Window Comparator

IC308/B^[E10] and IC308/C form a window comparator where the window width is adjusted by the mute sensitivity preset R358^[E9]. The divider network R360 and R361, together with C338, averages the output of IC309/B to provide the reference voltage for the window comparator. If the output from IC309/B rises above or falls below this reference by the amount set by R358, then the ORed outputs of IC308/B and IC308/C will discharge C339 applying a low to the input of comparator IC308/D on pin 10.

The second input at pin 11 of comparator IC308/D is set to 4 V by resistor dividers R365 and R366. When input pin 10 falls below 4 V, the comparator output at pin 13 goes high and indicates to the microcontroller IC403, via input pin 14, that speech has been detected.

Mute detection timing is controlled by discharging C339 through R362 for a fast attack, and charging of the capacitor via R363 for a slow release (about 3 seconds).

Control

☞ 04-02907 Sheet 2 and 3

When mute mode is selected by the mute switch on the front panel, a low is applied to input pin 29 on the microcontroller (IC403). The microcontroller sends via the I²C bus to IC405, instructions to latch output pin 21 (mute-out) low. This applies a low to the IC305/A pin 13, opening the mute gate and breaking the audio path to the volume control.

When speech is detected by the mute circuit, a high is applied from the comparator IC308/D pin 13 to the microcontroller (IC403) pin 14. The microcontroller, via the I²C bus, sets pin 21 of IC405 high. This closes the mute gate IC305/A and passes the received audio on to the volume control.

4.2.9 Volume Control and Audio Amplifier

The audio from the output of the mute gate passes through a ribbon cable to the volume control on the front panel.

The output of the volume control is passed to the loudspeaker amplifier IC2. The audio amplifier can supply 8 W into a 2 ohm load and supplies approximately 2 W to the internally fitted 8 Ω speaker.

4.3 Transmitter Exciter

4.3.1 Microphone Compressor

The microphone is connected via connector P100 on the front panel to an RF filter network R6 and C9 and then by ribbon cable to the main PCB (P401 pins 26 and 19). From here, the microphone speech passes to the input network of the microphone compressor amplifier.

☞04-02907 Sheet 2

The input network includes an analogue switch IC305/D^[H2], to disable the microphone when other transmit functions are selected.

The microphone compressor amplifier, consisting of IC303/B^[F3], IC306/A^[H3] and IC306B^[G3], V303^[G3] and associated components, provides a constant output level for a large variation in speech levels applied to the input.

With no speech present, amplifier IC303/B is set to maximum gain determined by feedback resistor R337 and shunt FET V303, functioning as a variable resistor and set to minimum resistance ($\approx 150 \Omega$).

The output of the amplifier IC303/B is connected to the inputs of IC306/A and IC306/B which form a window comparator. The window is set by the divider chain R330 to R342 to ± 0.25 V centred at 5 V.

When the level of speech applied to the microphone amplifier results in the output exceeding 0.25 V peak, the window comparators produce negative going output pulses lowering the DC charge on capacitor C238.

This effect reduces the voltage on the FET gate IC303, increases the effective resistance of the FET (IC303) and lowers the gain of the microphone amplifier.

The microphone amplifier is now in compression and the output level remains constant for any further increase in speech level.

The microphone amplifier has a compression range of approximately 30 dB.

4.3.2 Modulator

The microphone output is capacitor-coupled by C314^[D4] to the input of the balanced modulator IC301^[D3]. The modulator is enabled when DC is applied to the bias input pin 5 via R312 and transistor switch V9 (sheet 1^[B8]).

The audio mixes with the local oscillator of 456.5 kHz (453.5 kHz for LSB) applied to pins 8 and 10, to produce a DSB output at pin 6 that passes via D301^[C3] to the 455 kHz sideband ceramic filter Z301.

4.3.3 455 kHz Filter and First Mixer

04-02907 Sheet 1

Filter Z301 passes only the wanted sideband, via tuned transformer T5^[D9], to the input pins 12 and 13 of the first balanced amplifier/mixer IC9^[D7]. The mixer is enabled by operating transistor switch V9^[B8] and applying DC via R35 to the VCC input pin 4 and bias current via R38 to pin 11.

The 455 kHz transmit signal is filtered with the local oscillator VCO2 and applied to pin 5 to produce a second IF output signal centred on 45 MHz at pins 3 and 14. The mixer/amplifier has a gain of approximately 20 dB.

4.3.4 45 MHz Roofing Filter

The 45 MHz IF signal is filtered through a 15 kHz roofing filter consisting of T4, Z2, L10, Z1 and T3^[C5]. This removes unwanted products of the first mixer. The filter output is applied to the balanced input of the second mixer IC2^[D3] at pins 12 and 13.

4.3.5 Second Mixer and Exciter Output Filter

The second mixer IC2 is enabled by transistor switch V2^[B4], applying DC via R7 to the VCC input pin 4 and bias current via R8 to pin 11.

The 45 MHz transmit signal mixes with local oscillator VCO1 and is applied to pin 5, producing the selected channel frequency at the mixer output pins 3 and 14. The mixer/amplifier produces approximately 20 dB gain.

The mixer output is fed via a 20 MHz low pass filter to the transmit exciter output connector P1 pin 1 and 2. From here it couples via coaxial cable to the PA assembly.

4.4 Local Oscillators

4.4.1 Introduction

04-02907 Sheet 1

Two digitally controlled synthesized local oscillators drive the first and second mixers. VCO1 operates between 47 MHz and 63 MHz, moving in 2 kHz steps. VC02 operates between 44.5435 MHz and 44.5455 MHz, moving in 10 Hz steps.

The synthesizers are each programmed in serial data format from the microcontroller which accesses channel data stored in memory.

Each synthesizer is locked to the reference oscillator. This consists of a 7.304 MHz crystal oscillator held at a constant temperature of 60°C by a PTC thermistor oven.

4.4.2 VCO1 and PLL

VCO1^[E3] is designed around a differential amplifier consisting of FETs V3 and V4. The frequency of oscillation is determined by the tuned circuit L7, C23 and the capacitance of the varicaps D1 to D4. Oscillator output power is set by R14 and R15. Resistor R12 compensates the output level over the frequency range.

Capacitor divider C29 and C30 couple the oscillator output to the buffer amplifier V5, where the output drives the two mixers IC1 and IC2 and the prescaler IC4. In each case pin 5 is used as the input.

The high frequency output from VCO1 is divided by 64/65 prescaler IC4^[E5] down to a frequency range of 734 kHz to 984 kHz at pins 2 and 3. A high or low on pin 4 sets the division ratio.

IC5 is a complex PLL chip that contains two programmable dividers and a phase comparator. The phase comparator compares two input signals of the same frequency and outputs a voltage which is dependant on their relative phase.

One input to the comparator IC5 on pin 4 is from the prescaler IC4. This is divided to 2 kHz by one of the programmable dividers. Quartz crystal Z3 connected between pins 7 and 8 forms the reference oscillator set to a frequency of 7304 kHz. The reference oscillator is divided down to 2 kHz by the second fixed programmable divider.

The two divided signals are applied to the phase comparator and when the two signals are 'locked' in phase the comparator output is at mid-rail (2.5 V). As these two frequencies are locked together by the action of the loop, changing either programmable divider will change the VCO frequency.

Two separate outputs are available from the phase detector. PDB (pin 2 of IC5) is a coarse control that outputs a mark to space ratio proportional to the difference frequency between the divided signals. PDA (pin 1 of IC5) is the fine control and gives an analogue output that takes over from PDB when the two signals are close to phase lock.

Transistors V6, V7^[C3] with C38, R23, R26, and R27 form the loop filter. The input at the base of V6 is biased to 2.5 V by H1. The output DC can swing between ground and the positive rail and is used to control the varicaps and consequently the frequency of the VCO.

When a new channel is selected, the microcontroller changes the value of the programmable counter fed by the prescaler IC4. Because the two signals driving the phase detector are now no longer at the same frequency, the phase detector outputs pulses to the loop filter where the output ramps in the direction necessary to establish lock.

4.4.3 VCO2 and PLL

04-02907 Sheet 1

VCO2^[E7] is a crystal controlled Colpitts oscillator. The tuned circuit consisting of L15, C65 and C66 sets the appropriate frequency of operation. The network consisting of C63, Z4, D8 and L17 is equivalent to a voltage controlled, very high Q series tuned circuit. This network effectively grounds the gate of V9 at the series resonant frequency and determines the frequency of oscillation.

The drive to mixers IC8 and IC9 and the prescaler IC10 is via the capacitor divider C66 and C67, using pin 5 of each IC.

The phase locked loop incorporating VCO2 works in a very similar manner to PLL1. The main differences are:

- only one phase detector output is used to drive the loop amplifier IC11^[G7] pin 17
 - the phase comparator varies from 1.1 kHz to 2.0 kHz.
- Allowing the phase detector frequency to vary enables this loop to move in 10 Hz steps while having a high phase detector frequency.

The 7304 kHz reference oscillator output from pin 8 of IC5 is applied to pin 2 of PLL IC11.

The DC output at pin 1 of loop filter IC12/A^[H7], is applied to the varicap D8^[E6] and controls the frequency of the VCO.

4.4.4 455 kHz Local Oscillator

USB

For upper sideband the modulator/demodulator local oscillator is derived from the 7304 kHz reference oscillator divided by 16 (456.5 kHz).

The 7304 kHz reference oscillator (USB) is taken from the oscillator output pin 3 of IC11 and applied to the input of a $\div 2$ divider IC16A^[H8] at pin 3. The output pin 6 is applied to a second $\div 2$ divider IC16B pin 11 and the clock input of the microcontroller IC403 pin 16.

In USB mode, the second divider IC16B is enabled by the microcontroller selecting the enable line pin 10 high, at the same time disabling the 1814 kHz oscillator IC14/C pin 8.

The 7304 kHz $\div 4$ reference signal at pin 8 of IC16/B is fed via OR gate IC14/B to two cascaded $\div 2$ dividers IC15/A and IC15/B. This produces a balanced output at pins 8 and 9 at a frequency of 456.5 kHz. From here it is applied to the balanced local oscillator input of modulator IC301 (sheet 2) and demodulator IC302 pins 8 and 10.

LSB

For lower sideband a separate 1814 kHz crystal oscillator divided by 4 is used. In LSB mode, the output from divider IC16/B is disabled by the microcontroller at the same time enabling IC14/C^[F9], the 1814 kHz crystal oscillator.

The output from pin 10 of the oscillator is fed via OR gate IC14/B and dividers IC15A and IC15B to the modulator and demodulator for the local oscillator frequency of 453.5 kHz.

4.4.5 Clarifier

Operation of the clarifier on the front panel produces a code which is converted to serial data and read by the microcontroller. For each clarifier step detected, the microcontroller reprogrammes IC11, shifting VCO2 in 10 Hz steps from the nominal frequency. The clarifier range is ± 50 Hz for channels 2 MHz to 5 MHz and ± 10 ppm above 5 MHz. For example, the clarifier range at 18 MHz is ± 180 Hz.

The operation of the clarifier control varies the frequency of VCO2 in 10 Hz steps. This is done by varying both VCO2 and the reference frequency dividers according to a 'look-up' table in the transceiver's operating system. The phase comparison frequency varies from 1.1 to 2.0 kHz.

An audible indication is given when the clarifier reaches its upper or lower limit. The clarifier automatically resets to mid frequency when the channel is changed.

4.5 Micro and Peripherals

4.5.1 Microcontroller

The microcontroller monitors all input lines and outputs commands to various parts of the transceiver according to the information received and the program stored in the ROM.

The microcontroller IC403 is a member of Motorola's MC68HC05 family. The 8-bit microcontroller contains CPU, RAM, ROM, A/D, Pulse Length Modulated Outputs, I/O, serial Communications interface, Timer system and Watchdog.

4.5.2 I²C Bus

The serial data ports of the microcontroller IC403 pins 42 (data) and 44 (clock) provide the I²C bus to communicate to the following peripherals:

IC405 - I²C Bus/16 bit output driver

Commands from the microcontroller via the I²C bus, select the outputs of IC405 to control PTT, USB/LSB, TUNE, MUTE, AGC CLAMP, BCD lines for antenna control, UNLOCK 1 and 2 Leds, MIC enable and TX tones enable.

IC404 - EEprom

A non-volatile memory device that provides the microcontroller with the programmed channel information.

IC1-I²C bus/8 bit input

Provides the microcontroller with the front panel channel and clarifier control functions.

IC5 and IC11

The PLL integrated circuits which control VCO1 and VCO2.

4.5.3 PA Control Bus

A separate serial data bus is provided from the microcontroller (pins 37 and 38) to control an 8 bit driver IC1 on the PA PCB. This enables the microcontroller to select:

- the PA filters
- Antenna 1 or 2
- and the Tx/Rx changeover relay.

4.5.4 Front Panel Controls

04-02909

The front panel has the following controls:

Channel Change

A continuous rotatable 12 position switch provides a Gray code on its four outputs and is connected to IC1 pins 9 to 12. Channel selections are read by the microcontroller via the I²C bus. The microcontroller sets up VCO1 and VCO2 according to the information stored in the EEPROM. Only 10 of the 12 positions are used.

Clarifier

A continuous rotatable 12 position switch provides a Gray code on its four outputs and is connected to IC1 pins 4 to 7. Any position change in the receive mode is read by the microcontroller via the I²C bus.

The microcontroller adjusts VCO2 in 10 Hz steps to a limit depending on the channel frequency. The clarifier automatically resets to mid frequency when the channel is changed.

Emergency Call

A biased toggle switch provides a ground to pin 28 of microcontroller IC403. If enabled on the selected channel, the microcontroller selects the PTT function and outputs the two emergency tones of 880 Hz and 1320 Hz from pins 1 and 2. Modulator IC301 receives these signals via the microphone amplifier.

USB/LSB

A two position toggle switch provides the selection of USB or LSB by a high or low applied to pin 30 of microcontroller IC403. The microcontroller selects the appropriate local oscillator (applied to the modulator/demodulator).

The selection of USB and LSB is only available when enabled for the channel selected.

Tune/Mute Off/Mute On

A three position toggle switch, biased up for Tune select and selectable for Mute On/Mute Off.

When Tune is selected, a ground is applied to pin 32 of microcontroller IC403. This selects transmit mode and injects the carrier via IC14/A and V13 into the transmit path of the exciter.

When Mute On is selected, a ground is applied to pin 29 of microcontroller IC403. The microcontroller changes mute control line from IC308/D pin 13 to operate the mute gate IC305/A.

Power On

The power on switch is part of the volume control assembly. When the contacts are closed, relay K8 is energised on the PA PCB and provides the DC supply to the transceiver via contacts K8-1.

Volume

The volume control adjusts the audio level between the post mute output (IC305/A) and the speaker audio amplifier IC2 mounted on the front panel PCB.

4.5.5 Tune

☞04-02907 Sheet 1

When the tune function is enabled, a ground is applied to pin 32 of microcontroller IC403 [☞04-02907 Sheet 3] from the Tune switch. The microcontroller detects the ground and sets the output of IC405 pin 20 low via the I²C bus while applying a low on pin 15 thereby selecting transmit mode (PTT).

The output from pin 20 of IC405 is connected to pin 2 of NOR gate IC14/A [☞04-02907 Sheet 1]. When low, the 456.5 kHz carrier (453.5 kHz for LSB) connected to pin 3 of IC14/A, appears at the NOR gate output pin 1. This applies the carrier via the driver transistor V13 to the input of the first Tx mixer IC9.

The low from pin 20 of IC405 also connects to pin 11 of NOR gate IC14/D. This sets the output of IC14/D high and biases V12 into saturation. The output of the second cascaded NAND gate IC7/B pin 4 goes low opening FET gate V14. This stops the carrier being loaded by the sideband filter Z301.

4.5.6 Tone Generation

The tones are generated by the microcontroller IC403. Outputs from pins 1 and 2 (TCMP2 and TCMP1) are filtered by resistor/capacitor network R245 to R249 and C412 to C414, and provide the audible signals required for Emergency Call, alarm and warning tones.

4.5.7 A/D Inputs

☞04-02907 Sheet 3

The microcontroller monitors supply volts and the VSWR signals applied to its A/D inputs as follows:

Supply voltage

The A line supply volts is applied via resistor divider R410^[F4] and R413 to pin 3 of IC403. The microcontroller provides high alarm tone and disables the transceiver when the supply volts rises above 16.5 V. A low tone occurs when the supply drops below 10.5 V without disabling the transceiver.

Transmit forward power

The transmit forward power detector output from D1^[B2] (FWD-PWR) on the PA assembly is applied via resistor divider R409^[F3] and R412 to pin 12 of IC403.

Transmit reflected power

The transmit reflected power detector output from D2 (REF-PWR), on the PA assembly, is applied via resistor divider R411 and R413 to pin 3 of IC403.

Tune Pass/Fail

The microcontroller compares the forward and reflected power when in the tune mode and provides a pass or fail indication on completion of the tune cycle. A pass tone indicates a VSWR of < 3:1 and a fail tone indicates a VSWR of > 3:1.

4.5.8 Microcontroller Reset

☞04-02907 Sheet 3

The reset line to the microcontroller IC403 pin 18 is normally held to 5 V. Reset circuit IC304/B^[G4] and its associated components monitor the supply voltage on A line. When the supply falls below 8.7 V, the output of IC304/B applies a low via D403 to the reset pin 18.

To eliminate jitter on the reset line, resistor R417 provides a hysteresis to the reset network. This prevents the output of IC403 from going high until the supply has risen above 9 V.

4.6 PA and Filters

☞04-02908

Power Supply

The drivers and output stages (including part of the output bias circuit) are permanently connected to the supply voltage when the Power On relay K8 is energised. Power to the rest of the PA is switched by V2^[D9] when PTT is enabled.

Filter Selection

The selection of the PA filters and the operation of the PTT are controlled by the microcontroller. Serial data from the microcontroller IC403 is applied to IC1^[C4] (serial data input/8 bit output driver).

Depending on the channel frequency, the microcontroller selects the appropriate filter by grounding one of the output pins 14 to 18. In addition, pin 11 will be grounded or set high depending on whether antenna 1 or 2 is required (J1 or J2).

When PTT is selected, the microcontroller sends serial data to IC1 to select pin 12 to ground. This energises the transmit/receive changeover relay K7 and forward biases DC switch V1^[D3] providing DC to the input and predriver stages. The control circuit to the output bias circuit is enabled and the input DC is supplied to the +5 volt regulator IC2.

4.6.1 Gain Control Stage

04-02908

The RF input from the Exciter is terminated by R10^[G2] and drives the common base long tail pair V8^[F6] and V9 through R29 and R34 in parallel for signal currents. R30 sets the DC condition of the long tail pair and is RF bypassed by C77^[G6].

The gain of V9 is controlled by the ratio of emitter DC currents in V8 and V9. The RF input is split between the emitters of V8 and V9 inversely proportional to their input impedance. The gain of V9 reduces when the ALC increases the current in V8. The collector load of V9, consists of L19 and R33 which are frequency compensating components to reduce low frequency gain.

4.6.2 Predriver Stages

The collector output of V9 is coupled, via C76, to emitter follower V10 where the output drives the transformer feedback predriver stage V11. High frequency peaking in the emitter circuit is provided by L20 and C79.

4.6.3 Driver Stage

The push-pull class B driver stage, V13 and V14, is voltage driven from the secondary of T2^[E8]. The transformer output of T3^[E10] provides the current drive to the output stage and R49, L24 and C85 provide the low impedance source required below 3 MHz.

Bias for the driver stage is provided by the total current of the emitter follower and predriver stages passing through transistor V12 connected as a diode. The bias is set by SOT resistor R39 and changes the voltage across the collector-emitter of V12^[G8].

4.6.4 Output Stage and Bias Regulator

The push-pull class B output stage V18^[E11] and V19 is base driven from the centre tapped secondary winding of transformer T3. The centre tap provides the bias feed from the bias regulator.

The bias regulator V16 and V17 provides a constant voltage to the bases of V18 and V19. Transistors V16 and V17 form a feedback voltage regulator, the output voltage being the base-emitter voltage of V16, adjustable by preset potentiometer R45. Zener diode V15 and resistor R47 cause the bias to increase when the supply voltage drops below 11 V to reduce intermodulation distortion.

Transistor V16 is mounted on the PA heatsink and provides temperature compensation to the bias network.

The balanced to unbalanced impedance matching output transformer couples the power amplifier output via the transmit/receive relay K7 to the band filters.

4.6.5 Output Filters and Antenna 1 and 2 Select

The frequency range of 2 MHz to 18 Mhz uses five low pass filters selected by relays K2 to K6 and operated by IC1. The filters are selected to remove harmonics generated by the PA.

The output of the filter circuit passes through the Automatic Level Control (ALC) RF bridge to antenna output J1 or J2 as selected by relay K1.

4.6.6 ALC Control

04-02908

Automatic Level Control is provided from the following sources:

- Forward power
- Reflected power
- Output stage collector swing
- Battery voltage
- Heatsink over-temperature.

Control Inputs

The ALC control inputs are applied to V4 - V7 and the ORed output is connected via R20 to positive input (pin 5) of the ALC level comparator IC3/B^[F5]. The negative input (pin 6) is set to 3.6 V by the divider R22, R23, and R24.

PA Gain Control

In the absence of any ALC inputs, the output of IC3/B holds the base of V8 to 3.6 V. With V9 base referenced to 5 V, V8 cuts off setting V9 to maximum gain. An ALC control signal that causes any of the transistors V4 to V7 to conduct, results in the output of IC3/B rising to reduce the gain of V9, and therefore controls the gain of the PA.

The output voltage of the RF bridge T1, L1, R1, R2 and capacitor divider C3, C4, C5 and C6 is rectified by D1 for the forward power and D2 for the reflected power. The addition of L2 (Link X not fitted) allows for a reduction in output power at the frequencies above 12 MHz.

The output of the forward rectifier D1 is applied via divider R12 and R13 to R15 to input of V4 and determines the PEP power output level (set by SOT R14). D1 is also connected via R17 to input V5 and in conjunction with C68 sets the average power level to approximately 60 W.

The output of the reflected rectifier D2 is applied via divider R18 and R19 to input V6 and takes control of the ALC when the reflected power exceeds 10 watts ($> 2 : 1$ VSWR).

Peak output collector swing is monitored by R57^[G11], D8 for V18 and R54, D7 for V19. The diode cathodes are ORed and applied to V7^[F4] via divider R55 and R56. Transistor V7 conducts and limits the collector peak to 42 V to prevent damage to the output transistors.

Battery Voltage

The battery voltage is monitored by V3. When the supply volts (A line) drops to about 12 V the voltage at the base of V3, set by the resistor divider R8 and R9, falls to 4.3 V causing V3 to conduct. This causes a rise in voltage across R15 (part of resistor chain) and changes the threshold of the forward ALC detector, reducing the output power. As the control is linear, further reduction in supply volts continues to lower the output power.

Heatsink

When the heatsink exceeds 80°C, PTC resistor R22 rapidly increases in value, reducing the ALC threshold level to comparator IC3/B. This lowers the output power and prevents the heatsink from exceeding 90°C.



5

Maintenance

5.1 Introduction

This chapter provides maintenance and fault finding procedures that can be carried out on the X-2 transceiver. It covers general warnings and cautions to be observed when working with electronic equipment. It outlines fault finding steps when receive, transmit failures occur and provides removal and installation procedures. A section on unlocked synthesizers has been provided should VCO1 or VCO2 lose lock.

5.2 General

5.2.1 CMOS Devices

Complementary Metal Oxide Semiconductor (CMOS) devices in the Transceiver have built-in protection. However, their extremely high open-circuit impedance makes them susceptible to damage from static charges. Care must therefore be used when shipping and handling the devices and servicing equipment in which they are installed. The following precautions should be observed:

Packaging

Replacement CMOS devices are supplied in special conductive packaging. They should remain in this packaging until required for use.

Switch off

Ensure that power supplies are switched off before making connections or disconnections between circuit boards.

Handling

Handling of circuit boards and particularly touching any conductive parts should be kept to a minimum.

Grounding

Anything connected to or touching the circuit board tracks should be grounded. Observe the following:

- Test equipment connected to a board should be grounded through its mains lead.
- Static charges that may build up on a person can be discharged by touching a grounded metal surface with both hands. This should be done before, and at frequent intervals during work on circuit boards.
- Wearing a suitably grounded conductive wrist strap will minimise the static build-up on the person.

5.2.2 Circuit Boards

When servicing printed circuit boards the following should be observed:

Excessive heat

Excessive heat may lift the track from circuit boards, causing serious damage. Avoid the use of high powered soldering irons. A 60W maximum iron, preferably temperature controlled at approximately 370°C, is sufficient for most tasks. A slightly higher temperature (425°C) iron may be required for heavier components such as PA transistors. Apply the iron only long enough to unsolder an existing joint or to solder a new one.

Unsoldering

When unsoldering use a solder-sucker or Solderwick to remove solder.

CAUTION

Do not use sharp metal tools such as screwdrivers or twist drills as these will damage the printed circuit track.

Component substitution

Avoid unnecessary component substitution as this may damage the component, the circuit track or adjacent components.

Component replacement

When a component is diagnosed as defective, or the fault cannot be diagnosed in any other way than by substitution, observe the following when installing replacement:

- Axial leads - Components with axial leads, such as resistors and tubular capacitors, can often be replaced without unsoldering the joints on the boards. The defective component can be removed by clipping its leads close to the component leaving the leads soldered to the board. These leads should be straightened so that the leads of the replacement can be wrapped around them and soldered. After soldering, the excess lead should be clipped off.
- Remove solder - When a component has been unsoldered from the board ensure the holes are clear of solder before inserting the leads of the replacement.

CAUTION

Never force the leads through the holes as this will damage the circuit track, particularly where plated through holes are used.

- **Observe orientation** - Before replacing defective diodes, transistors, electrolytic capacitors or integrated circuits, observe any marking indicating polarity or orientation. It is essential that these types of components are installed with the correct connections. Consult the manufacturer's data for indications of the polarity of diodes or capacitors and transistors.
- **Heat sinking** - When soldering to the board, use long-nosed pliers or another form of heat sinking on the leads of heat sensitive components.
- **Thermal conduction** - When replacing transistors that are mounted on heat sinks, ensure good thermal conduction between the heat sink and the replacement. This can be done by cleaning the mounting surfaces and recoating them with a thermal conduction compound such as Jermyn Thermaflow A30.

Track repair

Broken or burned sections of printed circuit track can be repaired by bridging the damaged section with tinned copper wire. The section where the repair is to be made must be cleaned, observing the precautions outlined above before soldering.

Integrated circuit replacement

It is often possible to desolder and remove components from the board without damage to the component or the tracks on the board. However, integrated circuits with many connections, mounted on double-sided circuit boards with plated-through holes are almost impossible to remove intact and the operation is likely to damage the circuit boards. To replace these components their leads must be cut individually until the body of the component can be removed. Individual leads must be unsoldered and removed. Excess solder must be removed before inserting the replacement component. Refer to the bullet section "Remove solder" before inserting replacement components.

5.2.3 Transmitter Precautions

When taking measurements of the low level stages of the exciter it is advisable to remove the drive to the PA and Filter PCB. The supply voltage is applied to the PA when the transceiver is switched on. Due care should be exercised when connecting probes.

5.2.4 Probe Precautions

The following should be observed when connecting CRO probes to the Transceiver:

1. When connecting probes to the PA assembly, the earth clip lead should be wound around the body of the probe so that the earth clip just reaches the probe tip. This reduces stray RF pick-up.
2. The earth clip should be connected to the ground plane adjacent to the point of measurement to which the probe tip is connected.
3. It is not advisable to connect two probes at the same time, particularly when one is earthed to the PA ground plane and the other is earthed to the chassis. This may cause earth loop problems.
4. Probes should be connected after power has been applied to the transceiver and the test equipment. The earth connection should be made first and disconnected last.

5.3 Fault Diagnosis

5.3.1 General

The removal and replacement of components may damage the components and/or the printed circuit boards. In some cases it is impossible to remove components without destroying them. It is important therefore to carry out as much diagnosis as possible with components in situ. Specific tests are described later in this section. The following general points should also be of assistance:

Spare boards

If spare boards are held in stock, they may be substituted to localise the fault to one board.

Transistor tests (static)

Transistor failures are most often due to open-circuit base-emitter or base-collector junctions, or a short circuit between emitter and collector.

These types of faults can often be detected without removing the transistor, using the ohms range of an analogue multimeter or diode test on a digital multimeter. The two junctions should both give the appearance of a diode, i.e. high resistance with the multimeter leads one way round and low resistance when the leads are reversed. (Polarity depends on whether a PNP or NPN transistor is being tested). Resistance between collector and emitter should be high with the multimeter leads either way round. The circuit diagram should be examined for parallel paths before a transistor failing these tests is removed.

Transistor tests (dynamic)

Some transistor faults can be diagnosed by measuring voltages within the circuit. One of the most significant voltage measurements is the base-emitter voltage. The polarity of this will depend on the type of the transistor (PNP or NPN). A base emitter voltage between 0.6 and 0.8 V should be measured on a forward-biased base-emitter junction (double this voltage for a darlington transistor).

With its base-emitter junction forward biased the transistor should conduct. Some indication of satisfactory operation of the transistor can be obtained by measuring the voltage drop across its collector or emitter resistor and short circuiting its base to the emitter. The short circuit removes the forward bias cutting off the transistor, so that the voltage across the resistor is reduced considerably.

Integrated circuits

Before replacing an integrated circuit which has no output, make sure the fault is due to the IC or its load. As a general rule, if changes in input cause absolutely no changes in the corresponding output the IC should be suspected. If, however, even a very small change in output can be detected the load is more likely to be the cause. Depending upon the circuit further tests should be made by disconnecting resistors, capacitors, etc to verify this diagnosis before removing the IC.

Reading the Technical description and understanding how the Transceiver functions, will assist in diagnosing any possible faults that may occur.

5.3.2 Voltage measurements

The circuit diagrams and relevant circuit notes give voltages at various points under the various conditions to enable the faulty section of the Transceiver to be located. The parameters listed below should always be checked first:

The supply voltages used on the Rx/Exciter & Control PCB are:

'A' rail unregulated supply 13.6 V nominal.

'B' rail regulated supply (IC401) $+10\text{ V} \pm 0.2\text{ V}$.

+5VA regulated supply (IC3) $+5\text{ V} \pm 0.4\text{ V}$.

+5VB regulated supply (IC402) $+5\text{ V} \pm 0.4\text{ V}$.

TP6 switched supply (IC7/C), B rail voltage in receive, 0 V in transmit.

TP7 switched supply (IC7/D), B rail voltage in transmit, 0 V in receive.

The supply voltages used on the PA PCB are:

'A' rail unregulated supply 13.6 V nominal.

+5V regulated supply selected in transmit only (IC2) $+5\text{ V} \pm 0.4\text{ V}$.

Zener controlled supply to IC1 (V1) $+5\text{ V} \pm 0.25\text{ V}$.

5.3.3 No Reception

04-02907 sheet 1

For a receive failure:

1. Check the microphone plug is fitted. The link in the plug completes the audio path to the internal loudspeaker.
2. Check the Mute gate is operating and closed.
3. Check the supply voltages are correct as detailed in Section 5.3.2
4. Using a Signal Generator and a series capacitor (about 100 nF) apply a signal to the test points shown on the circuit diagrams. The receive levels and frequencies, shown on the RF and IF circuit diagrams, should cause the AGC to fall by about 0.5 V from its no signal level of approximately 5.2 V (under no fault conditions).
5. Start at the 455 kHz IF amplifier and proceed back through the receive path towards the antenna. When the injected signal is no longer heard or the AGC no longer falls by 0.5 V under application of levels shown on the circuit diagram, a close examination of the satisfactory and failed check points should indicate where the fault lies.
6. In the case of an audio fault, apply a signal from the Signal Generator to the receiver input at a frequency set to approximately 1 kHz above the channel frequency (1 kHz below for LSB). With the aid of an oscilloscope, trace the audio signal path from the demodulator output to the loudspeaker.

Note: If the AGC is operating satisfactorily then audio signal should be present at the output of pre-amplifier IC303/A, as this point also feeds the AGC detector circuit.

7. If the receive fault shows as an oscillation or instability, check that neither of the transmit mixers, IC2^[D3] and IC9, have DC on pin 4 or 11 (< 0.5 V). Check the modulator has no DC at pin 5. If DC is measured at any of the points indicated, check the following:
 - Check the base/emitter voltage to switching transistors V2^[B4] and V9. If it measures 0.5 V or more, check NAND gates IC7/C^[A6] and IC7/D output voltages are correct as shown on the circuit diagram.
 - If DC is measured on pin 4 and 11 of mixer IC2, unsolder and lift one side of resistor R7^[C4]. If the voltage still appears at the collector of V2, suspect collector/emitter leakage of transistor and replace. If the voltage still remains on pins 4 and 11 of the mixer, replace IC2.

- If DC is measured on pin 4 and 11 of mixer IC9, unsolder and lift one side of resistor R35^[C8]. Check if the DC is still on the mixer pins, replace IC2.
If the voltage is only on the collector of V9 and R35 is lifted, apply a short circuit between pin 5 of IC301^[D3] and ground [04-02907 sheet 2]. If the voltage goes from the collector of V9, replace modulator IC301. If the voltage remains on the collector with pin 5 shorted, replace V9 (collector/emitter leakage).

5.3.4 Transmitter Failure

For a transmit fault proceed as follows:

1. Check the supply voltages are correct as detailed in Section 5.3.2.
2. Apply an audio signal of about 1 kHz at a level of 10 mV RMS to the microphone input. Select transmit mode (PTT) and with the aid of an oscilloscope trace the audio, IF and RF signals through the transmit path. Check the measured levels correspond approximately to the levels shown on the circuit diagrams. A reduction of signal or complete failure at any of the check points should indicate the approximate location of the fault.

5.3.5 Unlocked Synthesizer

☞ 04-02907 sheet 1

Loss of lock on VCO1 or VCO2 is indicated by:

- a warning tone in the loudspeaker
- illumination of H1 and/or H2 on the Rx/Exciter & Control PCB.

Should the above warnings occur, proceed as follows:

1. Check the 18 V supply is present and connected to:
 - oscillator VCO1^[E2] (V3 and V4)
 - control amplifier V6^[G3] and V7.

If VCO2 has failed, check it is present at the control amplifier IC12/A^[H7].

2. Check VCO1 and VCO2 are oscillating. Check that the outputs at TP4^[E4] (VCO1) and TP1^[A2] (VCO2) are approximately the level shown on the circuit diagram. Frequency should be within the range indicated.
3. Check the output levels at pin 3 of the prescalers IC4^[E5] and IC10^[F7]. Check the frequency is approximately the VCO frequency divided by 64.
4. Check the VCO control voltages on TP3^[G1] and TP13^[F6] are within the limits indicated on the circuit diagram.

5. Check, whilst changing channels, the Enable, Data and Clock pulses are present at input of synthesizer integrated circuits IC5^[F5] at pins 12, 10 and 11 and IC11^[G7] at pins 13, 12 and 11.
6. If only VCO2 is unlocked and the previous checks appear correct, incorrect alignment may be the cause of failure. Re-set VCO2 as detailed in the VCO2 Adjust Section 7.6.3.

5.3.6 PA Failure

To optimise the amplifier performance, the PA output transistors are matched in pairs by a coloured dot or letter code. Measurements in this area depend upon the matched pair of transistors fitted and the frequency of transmission.

Table 5.1 provides a guide to the peak to peak voltages expected at the specified points in the PA circuit. They are given for full power output when driven with a two-tone input. For these tests the supply voltage should be 13.6 V and the output terminated into 50 Ω .

Frequency (MHz)	Battery (Amps)	V10 (Vpp)	V11 (Vpp)		V13/V14 (Vpp)		V18/V19 (Vpp)	
		E	C	E	C	B	C	B
2.5	9.5	0.20	0.40	0.20	1.10	0.20	20	2.2
3.5	9.5	0.20	0.45	0.25	1.10	0.20	20	2.3
5.5	9.5	0.25	0.45	0.25	1.10	0.20	25	2.7
8.5	10.0	0.35	0.60	0.40	1.20	0.27	28	3.2
15.5	9	0.55	1.30	0.60	1.00	0.70	35	4.0
17.9	10.0	0.60	1.50	0.60	1.10	0.80	20	4.5

Table 5.1: Peak to Peak Voltages

5.4 Dismantling and Assembling

5.4.1. General

It may be necessary to remove printed circuit boards from the transceiver in order to carry out certain repairs. The following paragraphs give instructions on the removal and installation of the boards. While carrying out these procedures the following general points should be observed:

Screwdriver

Screws with Pozidrive heads are used in almost all locations. Ensure that the appropriate screwdriver of the correct size is used.

Connectors

The ribbon cable header and multiway connectors used in locations can be incorrectly mated with their corresponding connectors. Care must therefore be taken when installing to ensure these connectors are correctly mated.

Removal of the screws securing the driver transistors V13^[E9] and V14 and bias transistor V17^[G10] on the PA assembly requires a 1/16 inch Allen key.

5.4.2 Top and Bottom Covers

To gain access to the printed circuit boards, the top or bottom cover must be removed from the transceiver. To remove either cover, the four screws (two on each side) must be removed and the cover lifted.

To replace the cover, place the cover onto the transceiver and refit the retaining screws.

5.4.3 Rx/Exciter & Control PCB

To remove the Rx/Exciter & Control PCB, disconnect the two ribbon cable connectors P3 and P401 and the Tx/Rx coaxial connector P1. Remove the five retaining screws and withdraw the PCB. Reverse the procedure to install, ensuring the ribbon connectors are aligned correctly.

5.4.4 Front Panel PCB

To gain access to the front panel PCB, remove the front panel from the frame of the Transceiver by removing the two retaining screws located on each side of the front surround. Disconnect the 26 way ribbon connector P401 from the Rx/Exciter & Control PCB and pull the front panel forward clear of the frame.

To remove the PCB:

1. Remove the three control knobs (secured by nuts under removable caps).
2. Carefully pull off the knobs on the three switches located above the control knobs.
3. Remove the nut securing the volume control.
4. Remove the connector to the microphone socket.
5. Remove the four retaining screws and carefully withdraw the PCB.

To install the PCB:

1. Reverse the procedure detailed above.

5.4.5 PA and Filter Assembly

The PA output transistors can be replaced without removing the PCB from the heatsink. Refer to paragraph 5.3.6.

Many of the components on the PCB are accessible once the PA assembly is removed from the main frame. Do not remove the PCB from the heatsink unless absolutely necessary.

To remove the PA PCB assembly:

1. Disconnect the ribbon connector P1 and the twin coaxial connector P2.
2. Remove the four retaining screws securing the rear panel to the main frame (two at each end of rear panel).
3. Remove the six screws securing the PCB to the septum panel:
 - one at each corner of the PCB (4 off)
 - one close to Tx/Rx relay K7
 - one longer screw (16 mm) located between output transistor V14 and the Driver Heatsink.
4. Carefully withdraw the PCB assembly from the main frame.

To remove the PCB from the heatsink:

1. Remove the PA assembly as detailed above.
2. Unsolder and remove the three capacitors C87 to C89 mounted between the bases of the output transistors V18 and V19.
3. Unsolder the wires and solder lugs fitted to the antenna sockets.
4. If the PCB is to be changed, unsolder and remove the negative and positive power leads from their mountings on the PCB.
5. Remove the four screws securing the output transistors V18 and V19.
6. Remove the remaining three screws securing the PCB to the heatsink.

Note: The 12mm long screw removed from the driver heatsink must be returned to this position when re-assembling.
7. Lift the PCB from the heatsink taking care not to damage the thermistor (R22) and transistor V16 recessed into the heatsink. Take care not to lose the mica insulator fitted under transistor V17.

To install the PCB to the heatsink:

1. Clean the underside of the output transistors V18/V19^[E11] and bias transistor V17. Clean the mating surfaces on the heatsink. Recoat these surfaces with new thermal compound (e.g. Jermyn Theraflow A30). Refit the mica insulator (if previously removed) coated with thermal compound. Check there is sufficient thermal compound in the two holes that locate the thermistor R22^[F4] and transistor V16^[G9].

2. Carefully refit the PCB to the heatsink taking care to locate R22 and V16 into their appropriate holes and check the mica insulator remains in place under transistor V17.
3. Loosely fit all screws (ensuring the longer screw is located in the driver heatsink), then tighten.
4. Reconnect the wires and solder lugs to the antenna sockets. Install the DC input power leads. Take care not to overheat the plastic insulation.

To install the PA PCB assembly to the main frame:

1. Carefully slide the assembly from the rear of the transceiver onto the septum panel. At the same time locate the Antenna Control connector J401 through the cut-out in the rear panel.
2. Once in position, refit all screws and tighten.

Note: The 16mm long screw is fitted in the hole located between transistor V19 and the driver heatsink securing the PCB via the heatsink to the septum panel.

Depending on the nature of the repair it may be necessary to reset the bias and power levels. Refer to PA adjustments in Chapter 7 for details.

5.4.6 Replacement of PA Transistors

The PA output transistors, V18^[E11] and V19, should only be replaced in matched pairs. The gain groupings of the SRFH1008 (selected MRF455) transistors are identified by a coloured dot or letter code. Only transistors of the same dot colour or code should be fitted.

The PA output transistors can be replaced without removing the PA and Filter PCB from the heatsink. It is necessary to release only the screws securing the transistors and to unsolder connections as follows:

1. Unsolder and remove the capacitors C87^[E10] to C89 located between the bases of the transistors.
2. Unsolder and lift the driver transformer T3 secondary winding from the transistor bases.
3. Cut and remove the cable tie supporting the output transformer T4 to the PCB.
4. Unsolder and lift the output transformer T4 primary winding from the transistor collectors.
5. Remove the flange fixing screws.
6. Use a desoldering tool or 'solder wick' to remove the bulk of the solder at each connection. Remove the solder lugs from the emitters of the transistors. Gently pull the transistor legs away from the PCB while heating the joints.
7. Clean away excess solder from transistor pads on the PCB.

8. Clean the transistor mating surface on the heatsink with a cloth or tissue.
9. Coat the transistor flange with a thin film of thermal compound (eg. Jermyn Thermaflow). Check the orientation and fit the new transistors.
10. Refit the four flange mounting screws complete with the three solder lugs. Tighten the screws evenly.
11. Carefully solder the transistor connections. This should be carried out quickly using a very hot tipped soldering iron.
12. Refit the output transformer complete with new cable tie, driver transformer and capacitors C87 to C89.
13. Re-adjust the bias current. Refer to Chapter 7 - Adjustments Section 7.11.



6

Channel Additions

Channel additions can be programmed from the microphone socket using an IBM compatible PC, or cloned from a second transceiver.

Details on how to program or clone information from another transceiver can be found in the XP User Guide supplied with the XP software.

Two cables are provided with the XP software package:

- one to connect the computer to the microphone socket
- one to clone information from another X-2 Transceiver.

Chapter 8 details the pin connections and functions of the front and rear connectors.



7

Adjustments

7.1 Introduction

Preset adjustments, which are normally factory-set, will require attention only if components that affect their settings are replaced. The X-2 Transceiver is provided with a special **Test Mode**, detailed in Section 7.5, to assist in alignment and checks of filters, local oscillators and channel frequencies.

7.2 Test Equipment Required

- Oscilloscope 50 MHz, complete with a 10X probe with a 10 M Ω and less than 15 pF input impedance.
- RF Dummy Load 50 Ω and Power Meter rated at 100 W RMS minimum.
- RF Signal Generator covering the range of 400 kHz to 18 MHz. Calibrated output signals from 10 millivolt to 0.5 μ V from a source impedance of 50 Ω .
- Frequency Counter 50 MHz with a resolution of 1 Hz.
- Regulated Power Supply of 13.6 V \pm 0.2 V at 20 A peak.
- Two tone Audio Generator operating at 700 Hz and 2300 Hz complete with 3 dB balance control and adjustable output 0-100 mV RMS.
- Digital Multimeter 10 M Ω input impedance.
- Transceiver Test Unit to Codan drawing 04-01868.
Note: The microphone isolating transformer should be fitted with a mu-metal screen to prevent mains 50 Hz pickup.
- Resistance Box fitted with E12 series resistor range 10 Ω to 1 M Ω assists in the selection of the SOT resistors.
- Spectrum Analyser for intermodulation measurements if required.

7.3 Voltage Regulators

None of the voltage regulators are adjustable. Only the output voltages can be checked at the following locations:

☞ 04-02907 Sheet 1 and 3

1. On the Rx/Exciter & Control PCB:
 - **TP402**^[B10] B' rail regulated DC (IC401) +10 V \pm 0.2 V.
 - **TP403**^[C7] +5V - A regulated DC (IC402) +5 V \pm 0.4 V.
 - **TP8**^[D5] +5V - B regulated DC (IC3) +5 V \pm 0.4 V.
 - **TP6**^[A4] Switched DC supply (IC7/C), B rail voltage in receive, 0 V in transmit.
 - **TP7** Switched DC supply (IC7/D), B rail voltage in transmit, 0 V in receive.

☞04-02908

2. On the PA PCB:
 - +5V regulated DC supply selected in transmit only (IC2) +5 V \pm 0.4 V. No test point provided but it can be checked at a number of places. For example: R11^[F2] or PTC R22^[E4].
 - Zener shunt controlled DC supply to IC1^[C4] (V1) +5 V \pm 0.25 V. This can be checked at pin 5 of IC1.

7.4 Crystal Oven

☞08-04840

The Crystal Oven, on the Rx/Exciter & Control PCB, is attached to the Reference Crystal Z3^[D3]. The oven should be checked after allowing five minutes warm-up period. The temperature operates between 50°C to 65°C and is not adjustable. Replace if the results are outside the specified limits.

7.5 Test Mode

The X-2 Transceiver is provided with a special **Test Mode** to assist in the following procedures:

- Alignment of the 45 MHz roofing filter using only an Oscilloscope, a Signal Generator and a simple jig made from an 18 Ω resistor and 470 μ F capacitor attached to clip leads.
- Alignment of the T5 and T6 in the 455 kHz IF circuit.
- Checking of VCO1 (not adjustable).
- Checking and adjusting of VCO2.
- Adjustment of the USB channel frequency.
- Adjustment of the LSB channel frequency.
- Checking the PA. The band switching, the intermodulation distortion at the top, bottom, and centre of each filter band.
- Adjustment of receiver sensitivity at 15 selected frequencies between 2 MHz to 18 MHz.

To select the **Test Mode**:

1. Switch off the Transceiver.
2. On the Rx/Exciter & Control PCB, remove the shorting link parked on the two ground pins of **Link 1** and **2** and fit to **Link 1**.
3. Switch on the Transceiver, which is now in the **Test Mode**.

4. In the **Test Mode** the channel switch has a 12 position function and the USB/LSB operates as an extension to the channel switch providing additional channel positions plus other special functions detailed in Table 7.1.
5. To return to **Normal Mode**: Switch off Transceiver, remove link from **Link 1**, return it to its normal parking position (ground pins of link 1 and 2). The transceiver will now be in its normal operating mode.

Channel position	Switch to USB Test frequency and function	Switch to LSB Test frequency and function
1.	2.00 MHz, USB, Band 1, Ant.1	11.6 MHz, USB, Band 5, Ant.1
2.	2.50 MHz, USB, Band 1, Ant.1	15.5 MHz, USB, Band 5, Ant.1
3.	3.00 MHz, USB, Band 1, Ant.1	17.9 MHz, USB, Band 5, Ant.1 [For USB frequency check]
4.	3.10 MHz, USB, Band 2, Ant.1	17.903 MHz, LSB, Band 5, Ant.1 [For LSB frequency adjust]
5.	3.50 MHz, USB, Band 2, Ant.1	18.0 MHz, USB, Band 5, Ant.2* For Ant.2 and Talk Power check.
6.	4.70 MHz, USB, Band 2, Ant.1	Not used
7.	4.80 MHz, USB, Band 3, Ant.1	45 MHz filter alignment [For use with CRO & Sig. Gen]
8.	5.50 MHz, USB, Band 3, Ant.1	VCO1 and 2 centre frequency
9.	7.40 MHz, USB, Band 3, Ant.1	VCO1 and 2 lowest frequency
10.	7.50 MHz, USB, Band 4, Ant.1	VCO1 and 2 highest frequency
11.*	8.50 MHz, USB, Band 4, Ant.1	45 MHz filter alignment [Use with Spectrum Analyser]
12.*	11.5 MHz, USB, Band 4, Ant.1	Not used

Table 7.1: USB/LSB Test Frequencies and Functions

Note: With the exception of channel position 5 - LSB, all other channel positions have **Talk Power Select Off** (pin 8 IC405 low). This enables the two-tone signal to be viewed on the Oscilloscope without the associated ripple in talk power mode.

*Channel positions 11 and 12 are not shown on the front panel escutcheon.

7.6 VCO Checks and Adjustments

7.6.1 VCO1 Check

08-04840

There is no adjustment for VCO1 located on the Rx/Exciter & Control PCB but a check can be made as follows:

1. Select **Test Mode** (refer to Section 7.5).
2. Select channel position 8 and USB/LSB to LSB.
3. Ensure the screening can is fitted over VCO1^[C4] and Mixer 1 for the following test.
4. Connect a DC voltmeter to TP3^[C4] and check for a reading of $7.7\text{ V} \pm 1.0\text{ V}$. The frequency at TP4 should measure approximately 55 MHz.
5. Select channel position 9.
6. Check the voltage at TP3 reads $3.2\text{ V} \pm 0.7\text{ V}$. The frequency at TP4 should measure approximately 47 MHz.
7. Select channel position 10.
8. Check the voltage at TP3 reads $12.7\text{ V} \pm 1.5\text{ V}$. The frequency at TP4 should measure approximately 63 MHz.
9. Should any of the measurements not be within the stated limits, check the VCO1 and associated circuits for possible faults.

7.6.2 VCO2 Check

08-04840

VCO2 located on the Rx/Exciter & Control PCB can be checked as follows:

1. Select **Test Mode** (refer to Section 7.5).
2. Select channel position 9 and USB/LSB to LSB.
3. Connect a DC voltmeter to TP13^[D6] and check for a reading of $3.0\text{ V} \pm 0.5\text{ V}$. The frequency at TP10^[C7] should measure approximately 44.5405 MHz.
4. Select channel position 8.
5. Check the voltage at TP13 reads $8.0\text{ V} \pm 1.5\text{ V}$. The frequency at TP10 should measure approximately 44.5445 MHz.
6. Select channel position 10.
7. Check the voltage at TP13 reads between 11.0–15.7V. The frequency at TP10 should measure approximately 44.5485 MHz.
8. Should the measurements not be within the stated limits, adjust VCO2 as detailed in section 7.6.3 **VCO2 Adjust**.

7.6.3 VCO2 Adjust

08-04840

To adjust VCO2:

1. Select **Test Mode** (refer to Section 7.5).
2. Select channel position 8 and USB/LSB to LSB.
3. Short together TP11^[D7] and TP12.
4. Connect an Oscilloscope to TP13^[D6] using the following settings:
 - **Y input** to 5 V per division (0.5 V/division if using 10X probe)
 - **Timebase** to 2 μ s per division.
5. Commencing from the bottom of the coil, adjust L15^[C6] tuning core for minimum repetition rate. Remove the short from TP11 and TP12.

 **CAUTION**

Great care must be taken to use the correct trimming tool to prevent damage to the tuning core.

6. Select channel position 9.
7. Connect a DC voltmeter to TP13. Commencing from the bottom of inductor L17, adjust the tuning core for a reading of $3.0 \text{ V} \pm 0.2 \text{ V}$. Frequency at TP10 should measure approximately 44.5405 MHz.
8. Select channel position 8.
9. Check the voltage at TP13 reads $8.0 \text{ V} \pm 1.5 \text{ V}$. The frequency at TP10 should measure approximately 44.5443 MHz.
10. Select channel position 10.
11. Check the voltage at TP13 reads between 11.0–15.7 V. The frequency at TP10 should measure approximately 44.5485 MHz.

7.7 45 MHz Filter Alignment

08-04840

There are two methods of aligning the 45 MHz roofing filter located on the Rx/Exciter & Control PCB:

1. Using an Oscilloscope and a Signal Generator.
2. Using a Spectrum Analyser with Tracking Generator.

Both methods are detailed in the following two sections.

7.7.1 Alignment - Method 1

The following steps detail the alignment procedure using an Oscilloscope and a Signal Generator:

1. Select the Transceiver **Test Mode** (refer to Section 7.5).
2. Select channel position 7 and the USB/LSB to LSB.
3. Connect a 470 μF 16 V electrolytic capacitor in series with an 18 Ω resistor between TP3^[C3] and 0 V (-ve of capacitor to 0 V).
4. Remove the shorting link parked on the two ground pins of **Link 3** and **4**^[D5] and fit to B-E of N/L TP15. This will open the noise limiter gate.
5. Connect and set a Signal Generator to a frequency of 8.4 MHz \pm 100 Hz and an output of 6.3 mV EMF to the receiver input.
6. Connect an Oscilloscope with a 10X probe to TP14^[B7]. Connect External Trigger input to **Trig**^[D4] Test Point on the PCB. Set the Oscilloscope to the following settings:
 - **Channel One** to 20mV/division (this equals 0.2V/division with the attenuation of the 10X probe).
 - **Timebase** to 2ms/division.
 - **Trigger External**. Adjust the trigger for a constant sweep.
7. Adjust transformers T3^[B6] and T4 and inductor L10 for minimum ripple response. (Refer to Figure 7.1.)

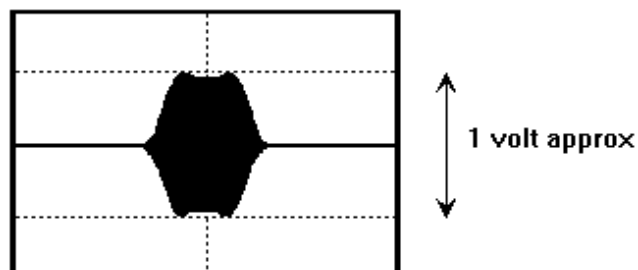

Figure 7.1: Ripple Response

8. Remove the shorting link to **B-E** and return it to its parking position (ground pins of **Link 3** and **4**).

7.7.2 Alignment - Method 2

The following steps detail the alignment procedure using a Spectrum Analyser and Tracking Generator:

1. Select the Transceiver **Test Mode** (refer to Section 7.5).
2. Select channel position 11 and the USB/LSB to LSB.
3. Remove the shorting link parked on the two ground pins of **Link 3** and **4**^[D5] and fit link to B-E of N/L TP15. This will open the noise limiter gate.
4. Connect the Tracking Generator set to an output of 7 mV RMS (-30 dBm) direct to the receiver input (P1 pin 1 and ground pin 2) on the Rx/Exciter & Control PCB. This will by-pass the Broadcast Filter.
5. Connect the Spectrum Analyser input to TP14^[B7] (50 Ω input is permitted). Set up the Spectrum Analyser as follows:
 - Centre frequency to 455 kHz.
 - Frequency span to 100 kHz (10 kHz/Div).
 - Reference set to 10 dB per division.
6. Adjust the Spectrum Analyser sensitivity to about -50 dBm to display the frequency response of the 45 MHz roofing filter.
7. Adjust transformers T3^[B5] and T4 and inductor L10 for less than 2 dB ripple over 15 kHz span centred at 455 kHz. If desired, the reference level can be changed to 2 dB per division to improve resolution.

Note: In this **Test mode** VCO1 and VCO2 are set to 44.544 MHz enabling the receive frequency to equal the 455 kHz IF frequency. This allows the Spectrum Analyser and Tracking Generator to be used to align the roofing filter at 455 kHz.
8. Remove the shorting link to **B-E** and return it to its parking position (ground pins of **Link 3** and **4**).

7.8 455 kHz IF and N/L Alignment

08-04840

There are two tuned transformers in the 455 kHz IF circuit located on the Rx/Exciter & Control PCB:

- T5 in the IF path to the Sideband Filter.
- T6 is located at the output of the noise limiter 455 kHz amplifier.

The alignment may be carried out either in the **Test Mode** or normal operating mode.

To align the two transformers:

1. Select any receive channel.
2. Connect a Signal Generator set to 1 kHz above the selected channel frequency (1 kHz below for LSB) at an output of about 10 mV EMF to the receiver input.

3. Fit a shorting link to **B-E** to disable the noise limiter gate (located at the rear of the Rx/Exciter PCB adjacent to the Antenna control connector J401^[A10]).
4. Connect an Oscilloscope using a 10X probe to TP14^[B7]. Set the Oscilloscope to the following:
 - **Timebase** to 50 μ s/division.
 - **Channel One** to 50mV/division (equals 0.5V/division with the attenuation of the 10X probe).
 - **Trigger** set to auto sweep.
5. Adjust T5^[B7] for maximum amplitude.

Note: Only a small change in amplitude will be seen due to the low Q of the tuned circuit.
6. Remove the 10X probe from TP14.
7. Connect a 1X probe to position A (part of N/L TP15). Set the Oscilloscope to a sensitivity of 10 mV/division.
8. Adjust T6^[A7] for maximum amplitude.
9. Remove the shorting link to **B-E** and return it to its parking position (ground pins of **Link 3** and **4**).
10. Remove the 1X probe from position A.

7.9 Frequency Adjustment

08-04840

All the channels are synthesised and locked to the 7304 kHz reference crystal (Z3) oscillator. The reference crystal divided ($7304 \text{ kHz} \div 16$) provides the local oscillator to the Modulator and Demodulator in USB mode. Therefore it is only necessary to adjust the reference frequency for all channels on USB.

An additional divided crystal oscillator ($1814 \text{ kHz} \div 4$) provides the local oscillator to the Modulator and Demodulator in LSB mode.

7.9.1 Frequency Adjust USB

To adjust the USB frequency:

1. Select the Transceiver **Test Mode** (refer to Section 7.5)
2. Select channel position 3 and the USB/LSB to LSB (this selects test channel 17900 kHz USB).

3. Remove the coaxial connector P1 on the Rx/Exciter & Control PCB (removing the exciter output to the PA).
4. Connect a Frequency Counter to Exciter output (**Tx** and ground).
5. Hold the Tune/Off/Mute switch in the **Tune** position.
6. Adjust trimmer C51^[D3] (reference crystal adjust) to a frequency of 17900 kHz \pm 5 Hz.

Note: Allow at least five minutes from switch-on before adjusting the frequency.

7.9.2 Frequency Adjust LSB

To adjust LSB for frequency:

1. First adjust frequency in the USB as detailed in Section 7.9.1. Remain in the **Test Mode** and leave the frequency counter connected.
2. Select channel position 4 and the USB/LSB to LSB (this selects test channel 17903 kHz LSB).
3. While holding the Tune/Off/Mute switch in the **Tune** position adjust C97^[E7] for 17903 kHz \pm 5 Hz.

7.10 Mute Adjustment

08-04840

The Mute is located on the Rx/Exciter & Control PCB. The adjustment procedure is as follows:

1. Connect the Transceiver to an antenna (a short length of wire will do). Select an unoccupied channel.
2. Select **Mute On** located on the front panel.
3. Commence with preset potentiometer R358^[E8] fully counter-clockwise. Slowly rotate the control clockwise until the mute gate closes and the receiver noise is heard in the loudspeaker (mute threshold).
4. Rotate the control back in a counter-clockwise direction for 1/4 of a turn.
5. The mute should now be sensitive enough to operate on the weakest signal without false triggering on noise pulses. The sensitivity may be varied from this setting to suit individual requirements (clockwise to increase sensitivity).

7.11 PA Adjustments

7.11.1 Driver Bias

To check and adjust the driver bias:

1. Disconnect exciter output to the PA by removing connector P2 on the PA PCB assembly.
2. With the Transceiver off, unsolder **Link DR** (DC supply to the driver transistors V13 and V14). Connect a Multimeter set to DC current 100 mA in place of the removed link (+ve to the right).
3. Switch on the Transceiver selected to any transmit channel and operate the PTT (transmit mode). Check the driver current measures 18 mA \pm 3 mA.
4. If the current is out of the specified limit stated in step 3 it can be changed by selecting an alternative SOT resistor R39.
5. Switch off the Transceiver, disconnect Multimeter and replace **Link DR** with a length of 22 gauge TCW.

7.11.2 PA Bias

To check and adjust the output PA transistors bias:

1. Disconnect exciter output to the PA by removing connector P2 on the PA PCB assembly.
2. With the Transceiver off, unsolder **Fuse PA/OP** (DC supply to the output transistors V18 and V19). Connect a Multimeter, set to DC current 1A, in place of the removed fuse (+ve to the left).
3. Switch on the Transceiver selected to any transmit channel and operate the PTT (transmit mode). Check the output transistor current measures 120 mA \pm 10 mA.
4. If the current is out of the specified limits stated above, adjust preset potentiometer R45^[C5] to the correct current level.
5. Switch off the Transceiver and replace **Fuse PA/OP** with three strands taken from a piece of ribbon cable. Solder the wire to the two stakes extending the centre of the wire up to form an inverted Vee. Only solder at the wire ends attached to the stakes.

7.11.3 Output Power

To set the output power:

1. Ensure the Exciter output is connected to the PA PCB Assembly (P1 to P2).
2. Select channel position 5 and the USB/LSB to USB. This selects the channel frequency 3500 kHz, USB, and Antenna 1 O/P.
3. Connect an RMS or PEP Power Meter with a 50 Ω Dummy Load to Antenna 1 connector.
4. Connect the Oscilloscope via a 47 k Ω resistor to Antenna 1 connector. Alternatively a Tee piece with an attenuated output of approximately 40 dB can be connected to the oscilloscope.
5. Set the Oscilloscope to the following settings:
 - **Timebase** to 500 μ s/division
 - **Trigger** set to auto sweep.
6. Apply the two tone audio via the Test Unit to the microphone socket.
7. Select the Transceiver **Test Mode** (refer Section 7.5).
8. Select transmit (PTT) and adjust the two tone level for microphone compression.
9. Adjust the Oscilloscope 'Y' sensitivity for on-screen display and adjust the trigger for a stationary waveform.
10. Adjust the two tone balance control for good crossover display.
11. Select a value for the **Set PWR** SOT resistor R14^[C3] on the PA PCB for the following output power:
 - For Australian use - 100 W PEP. Link X should be fitted to prevent reduced power at 18 MHz.
 - For use outside Australia - 125 W PEP. Link X should **not** be fitted. This will allow the output power to fall to about 100 W at 18 MHz.

Note: The indicated PEP level with two tone modulation will depend upon the type of measuring instrument as shown in Table 7.2.

Power output PEP	100 W	125 W
Peak reading meter	100 W	125 W
RMS reading meter	50 W	62.5 W
Average reading meter (Bird Model 43)	40.5 W	50.6 W

Table 7.2: **Power output PEP vs Measuring Instrument**

12. Check the two tone waveform is clean and undistorted.
13. The output power is factory set and not likely to be outside the specified limits. First check there are no faults with the transmitter circuits before attempting to adjust the power output.

7.11.4 Intermodulation

The **Test Mode** provides 15 channel frequencies to check the PA on the five bands. One at the start of each band, one in the centre, and finally one at the top of each band.

A Spectrum Analyser is required to test the Intermodulation Distortion (IMD). The check procedure is as follows:

1. Ensure the Exciter output is connected to the PA PCB Assembly (P1 to P2).
2. Connect a 50 Ω Dummy Load to Antenna 1 output via a suitable in-line Tee piece to provide a low level output to connect to a Spectrum Analyser.
3. Select the Transceiver **Test Mode** (refer Section 7.5).
4. Select first channel position 1 and the USB/LSB to USB. This selects the channel frequency 2000 kHz, USB, and Antenna 1 O/P.
5. Apply the two tone audio (700 Hz and 2300 Hz) via the Test Unit to the microphone socket.
6. Set up the Spectrum Analyser as follows:
 - Centre frequency to 2000 kHz.
 - Frequency span to 20 kHz (2 kHz/div).
 - Reference to 10 dB/division.
 - Video bandwidth to 300 Hz.
 - Sensitivity will depend on the signal level applied to the Analyser and will require adjustment when transmitting.
7. Select PTT (Tx mode) and adjust the two tones for compression. If this level is unknown it can be checked by observing the output of the Microphone Amplifier at TP302 using an Oscilloscope for 500 mV pp.
8. Adjust the two tones for equal amplitude displayed on the Spectrum Analyser by operating the balance control on the two tone Signal Generator. Adjust the Sensitivity control on the Spectrum Analyser to set the two tones at the top of the screen.
9. The Intermodulation distortion levels at 2000 kHz can be measured with respect to each tone. Add 6 dB to the reading if referenced to PEP (refer Specifications Section 1.6.3 for limits).
10. The Intermodulation distortion can be checked on the other available 14 frequencies by selecting the **Test Mode** channels detailed in Table 7.1 in Section 7.5. The Spectrum Analyser centre frequency will need to be set to the channel frequency selected.

Note: By adjusting the Spectrum Analyser frequency span it is also possible to check the Spurious and Harmonic components during the IMD checks.

7.12 Receiver Performance Checks

7.12.1 Sensitivity and S+N/N ratio

Connect an AC Voltmeter across the audio output. Set the Signal Generator frequency 1 kHz above the SCF of the selected channel (1 kHz below for LSB) and connect the output, set to 0.4 μV PD, to the selected Antenna socket. Adjust the volume control for a suitable near full scale dB reading on the AC Voltmeter. Take note of the reading.

Switch off or adjust the Signal Generator output to a frequency outside the receiver passband and check that the audio output drops by at least 10 dB.

7.12.2 AGC Check

Set up as for the Sensitivity test (refer to Section 7.12.1) but with the Signal Generator output set to 50 mV PD. Adjust the volume control for a suitable near full scale dB reading on the AC Voltmeter. Take note of the reading.

Reduce the Signal Generator output until the receiver output drops by 6 dB. The Signal Generator level should be less than 2.5 μV PD.

7.12.3 Audio Output

Set up as for the Sensitivity test (refer to Section 7.12.1) but with the Signal Generator output set to 50 μV PD. Connect an Oscilloscope in parallel to the AC Voltmeter across the audio output.

Increase the Volume control and check the audio output exceeds 4 V RMS at the onset of clipping displayed on the Oscilloscope.

Note: For this test it is permissible to replace the loudspeaker with a 5 W 8 Ω resistor.

7.12.4 Selectivity (USB operation)

Set up as for the Sensitivity test (refer to Section 7.12.1) but with the Signal Generator output set to 0.5 μV PD and note the audio output reference level on the AC meter.

With a Frequency Counter monitoring the Signal Generator, adjust the frequency to -1 kHz and then to +4 kHz from SCF. Increase the Signal Generator to 0.5 mV PD (+60 dB above 0.5 μV) and check the audio output is less than the reference level at both frequencies.

7.12.5 Clarifier Operation

Set the Signal Generator frequency 1 kHz above the SCF of the selected channel (1 kHz below for LSB) and connect the output, set to any level between 0.4 μ V and 10 μ V PD, to the selected Antenna socket.

Check the audio frequency changes with rotation of the Clarifier in a clockwise and counter-clockwise direction. Check also that pips are heard at the limits of each end of the control.

7.12.6 Noise Limiter Operation

Set the Signal Generator frequency 1 kHz above the SCF of the selected channel (1 kHz below for LSB) and connect the output, set to 0.4 μ V PD, via a Tee piece to the selected Antenna socket.

To the unoccupied socket of the Tee piece add a BNC to Two-Terminal adaptor. Connect the output of a Square-wave Generator via a 100 pF capacitor to the adaptor. Set the Square-wave Generator frequency to a 100 Hz and the output to 5 V peak to peak.

The Noise Limiter is normally **ON** and the signal produced by the Signal Generator should be clearly heard over the interfering signal from the Square-wave Generator.

When the Noise Limiter is switched off, by shorting A to E on N/L test point on the Rx/Exciter & Control PCB, the noise from the Square-wave Generator should swamp the wanted signal from the Signal Generator. This test will verify the Noise Limiter is functioning correctly.

7.13 Transmitter Performance Checks

7.13.1 Frequency Check

Check as detailed in the Frequency Adjustment Section 7.9.

7.13.2 ALC

Use the Transceiver Test Unit with two tone audio source to modulate the transmitter. In the transmit mode, slowly increase the audio output until the output power just ceases to increase (ALC threshold).

Note the PEP output and increase the audio input by 20 dB. The increase in output should be less than 0.5 dB above the ALC threshold.

7.13.3 Power Output and Intermodulation

For Australian use:

Power output 100 W PEP \pm 0.5 dB (solder Link 'X' fitted). Intermodulation distortion should be better than -32 dB below PEP (-26 dB below each tone) as measured with a Spectrum Analyser. Use 700 Hz and 2300 Hz tones.

For use outside Australia:

Power output 125 W PEP at 2 MHz reducing to 100 W at 18 MHz (solder Link 'X' **not** fitted). Intermodulation distortion should be better than -32 dB below PEP (-26 dB below each tone) as measured with a Spectrum Analyser.

Note: The indicated PEP level with two tone modulation will depend upon the type of measuring instrument used. See Table 7.2 in Section 7.11.3.

7.13.4 Emergency Call

The Emergency Call facility is for use with the Australian Royal Flying Doctor Service.

The two-tone modulation frequencies of 880 Hz and 1320 Hz are determined by the software in the Microcontroller. Therefore it is only necessary to carry out a function check as follows:

- 1 Connect a 50 Ω Dummy Load to the selected Antenna Connector complete with Power Meter.
- 2 Connect an Oscilloscope via a 47 k Ω resistor to the Antenna Connector.
- 3 Select a channel with Emergency Call enabled.
- 4 Operate the **EMGCY CALL** on the front panel and check the following:
 - The output power equals approximately 100 W PEP.
 - The two modulating tones are approximately of equal amplitude (viewed on the Oscilloscope).
 - The modulating tones are heard in the loudspeaker.



8

Appendices

Appendix A: Connectors

The following tables detail the pin connections and functions of the front and rear connectors. Details are also provided for the cables used for channel and cloning programming.

A.1 Microphone

Pin No.	Function	Signal Levels
1	PTT Ground	0 V
2	PTT Active	Active Low
3	Microphone Ground	0 V
4	Microphone Input	50 mV P-P 8 k Ω I/P Imp.
5	Speaker Ground Return	* See note below
6	Speaker Audio Output	12 V P-P max. 4 Ω min.
7	Speaker Ground	0 V

Table A.1 Microphone Connector pin function.

*Note: Link pin 5 to pin 7 for front panel speaker operation.

A.2

External Loudspeaker

Pin No.	Function	Signal Levels
Tip	Speaker Audio Output	12V P-P max. 4 Ω min.Imp.
Sleeve	Ground	0 V

Table A.2 External loudspeaker connector pin function.

A.3 Antenna Control

Pin No.	Function	Signal Levels
1	BCD Channel Number 4	Open Collector Active Low
2	BCD Channel Number 8	Open Collector Active Low
3	No Connection	
4	No Connection	
5	No Connection	
6	No Connection	
7	No Connection	
8	PTT Out	100 k Ω Source Active High
9	BCD Channel Number 1	Open Collector Active Low
10	BCD Channel Number 2	Open Collector Active Low
11	No Connection	
12	A Rail	Nominal +12 V
13	A Rail	Nominal +12 V
14	Ground	0 V
15	Ground	0 V

Table A.3 Antenna control connector pin function.

A.4 Programming Cable

9 Way Computer Serial Port Socket	7 Way transceiver Microphone Socket	Pin Function
2	1	Data from Transceiver
3	2	Data to Transceiver
5 *Series Thermistor (Thermistor =50 Ω 80°C)	3	Ground
	5/7 link	Speaker Link

Table A.4 Programming cable connector pin function.

A.5 Cloning Cable

7-Way Transceiver Microphone Socket	7-Way Transceiver Microphone Socket	Pin Function
1	2	Data I/O
2	1	Data I/O
3	3	Ground
5/7 link	5/7 link	Speaker Link

Table A.5 Cloning cable connector pin function.



Appendix B: Parts Lists

B.1 General Information

The parts lists for the PCB assemblies contain:

1. Circuit Reference Number.
2. Descriptions, giving the value and type of component.
3. Manufacturer and Manufacturer's Part Number.
4. CODAN Part Number.

Note: Items having numeric references identifying specific components or subassemblies may be encountered in the parts lists included in this manual. These items, selected from master manufacturing information, identify parts which either are useful for maintenance purposes or relate to other items and may be cross referenced in the remarks column.

Table B.1 lists the abbreviations for resistor and capacitor types.

Resistors	Capacitors
CC- carbon composition	AS- solid aluminium electrolytic
CF- carbon film	CC- ceramic multilayer chip
MF- metal film	CE- ceramic
MG- metal glaze	EL- wet aluminium electrolytic
MO- metal oxide	M- stacked mica
WW- wire wound	PC- polycarbonate
	PE- polyester
	PP- polypropylene
	PS- polystyrene
	PT- PTFE
	TA- solid tantalum

Table B.1 Resistor and capacitor abbreviations.

B.2 Ordering Information

Orders for replacement components must include the following information. This will ensure that the correct parts are supplied and help speed up delivery times.

1. Equipment type (e.g. Type X-2 Transceiver).
2. Component location (e.g. Rx/Exciter & Control PCB, 08-04840).
3. Component circuit reference number (e.g. R74).
4. Full component description (e.g. Resistor 470Ω 5% 0,33W CF Res).
5. Manufacturer (e.g. Philips)
6. Manufacturer's Part Number (e.g. 2322 211 13471).
7. CODAN Part Number (e.g. 40-24700-020).

B.3 Component Substitution

When replacing general purpose components (resistors, capacitors etc.), equivalent parts from other manufactures may be used provided they have similar tolerances, voltage/power rating and temperature coefficients as those of the specified part.

Substituting components which do not exactly match those listed in the parts list will not adversely affect equipment performance.

B.4 Parts Lists

Four parts lists can be found in this section as shown in Table B.2.

Page	Title	Assembly No
8-5	Sundry Parts	08-04843
8-6	Front Panel Assembly	08-04842-000
8-8	Rx/Exciter & Control	08-04840-001
8-18	PA and Chassis Assembly	08-04841-001

Table B.2 Parts list index

Appendix C: Engineering Drawings

The Engineering Drawings in this appendix consist of the mechanical and electrical diagrams required to maintain the X-2 Transceiver.

The List of Drawings in Table C.1 details their order of appearance in this appendix.

Title	Drawing No
Mechanical Layout	16-00107
X-2 Block Diagram	03-00876
Interconnection Diagram	04-02910
Front Panel	04-02909
Front Panel PCB Assembly	08-04842
Rx/Exciter & Control (3 Sheets)	
- RF & Dual Synthesiser	04-02907 Sheet 1
- 455kHz IF & Audio	04-02907 Sheet 2
- Micro & Peripherals	04-02907 Sheet 3
Receiver/Exciter Assembly	08-04840
PA & Filter	04-02908
PA & Filter PCB Assembly	08-04841

Table C.1 List of Drawings.

Appendix D: Glossary of Terms

D.1 Abbreviations

Abbreviation	Meaning
A/D	Analog to digital
AGC	Automatic Gain Control
ALC	Automatic level control
B	Transducer
B-E	Base - Emitter
BCD	Binary-coded decimal
C	Capacitor
CMOS	Complementary metal oxide semiconductor
CPU	Central processing unit
CRO	Cathode-ray oscilloscope
CW	Continuous wave; Carrier wave
D	Diode - small signal and power
DC	Direct current
E	Heating devide
EEPROM	Electrically erasable/programmable read-only memory
EMF	Electromotive force
Emgcy	Emergency
FET	Field-effect transistor
FWD-PWR	Forward Power
H	Signalling/indicating device; Lamp; Buzzer
HF	High Frequency
I/O	Input/Output
I ² C	Inter IC Communication
IC	Integrated Circuit
IMD	Intermodulation distortion
IF	Intermediate Frequency
J	Jack Socket
K	Relay; Key Switch
L	Inductor
LED	Light Emitting Diode
LSB	Lower Side Band
MIC	Microphone
NAND	Not AND logic
O/P	Output
OR	Logical OR function
NOR	Negative OR function
P	Plug
PA	Power amplifier
PA/OP	Power amplifier/Output
PC	Personal computer
PCB	Printed circuit board
PD	Potential difference
PEP	Peak envelope power
PLL	Phase-locked loop
ppm	Parts per million
PTC	Positive temperature coefficient (Resistor)

Abbreviations (cont'd)

Abbreviation	Meaning
PTT	Push-to-talk
PWR	Power
Q	Quality factor
R	Resistor
RAM	Random Access Memory
REF-PWR	Reference-Power
RF	Radio frequency
RFDS	Royal Flying Doctor Service
RMS	Root mean square
ROM	Read Only Memory
Rx	Receive; Receiver
S	Switch
SCF	Suppressed carrier frequency
SINAD	Signal + Noise + Distortion-to-Noise + Distortion Ratio
SOT	Select on test
SSB	Single Side Band
T	Transformer
TCW	Tinned copper wire
TP	Test point
Tx	Transmit; Transmitter
UHF	Ultra High Frequency
USB	Upper Side Band
VCO	Voltage-controlled oscillator
VSWR	Voltage standing wave ratio
Z	Quartz Crystal; Crystal Filter; Frequency Network

Table D.1 Abbreviations.**D.2 Units**

Abbreviation	Unit	Abbreviation	Unit
A	ampere	m	metre
°C	Celsius (degrees)	min	minute
C	coulomb	N	Newton
dB	decibels	Pa	Pascal
F	farad	S	Siemens
g	gram	s	second
h	hour	T	Telsa
H	henry	V	volt
Hz	Hertz	Wb	weber
J	joule	W	watt
K	Kelvin	Ω	ohm
l	litre		

Table D.2 Abbreviations of Units.

D.3 Unit Multiples

Abbreviation	Prefix	Numeric	Meaning
T	tera	10^{12}	one million million
G	giga	10^9	one thousand million
M	mega	10^6	one million
k	kilo	10^3	one thousand
h	hecto	10^2	one hundred
da	deca	10	ten
d	deci	10^{-1}	one tenth
c	centi	10^{-2}	one hundredth
m	milli	10^{-3}	one thousandth
μ	micro	10^{-6}	one millionth
n	nano	10^{-9}	one thousand millionth
p	pico	10^{-12}	one million millionth

Table D.3 Abbreviations of Unit Multiples.



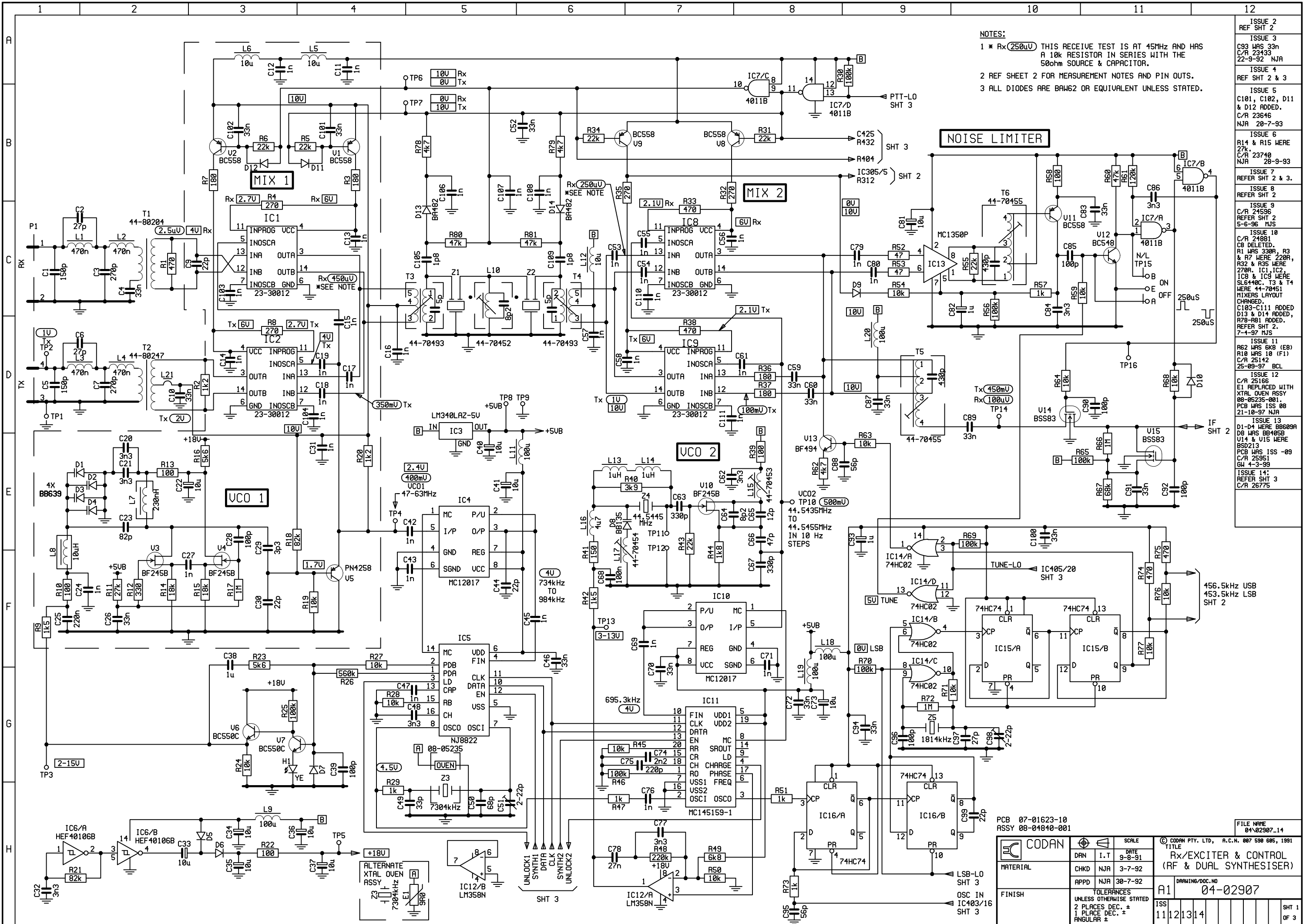

NOTES:
 1 * Rx (250uV) THIS RECEIVER TEST IS AT 45MHz AND HAS A 10k RESISTOR IN SERIES WITH THE 50ohm SOURCE & CAPACITOR.
 2 REF SHEET 2 FOR MEASUREMENT NOTES AND PIN OUTS.
 3 ALL DIODES ARE 1N4148 OR EQUIVALENT UNLESS STATED.

ISSUE 2
REF SHT 2

ISSUE 3
C93 WAS 33n
C/R 23433
22-9-92 NJA

ISSUE 4
REF SHT 2 & 3

ISSUE 5
C101, C102, D11
& D12 ADDED.
C/R 23646
NJA 20-7-93

ISSUE 6
R14 & R15 WERE
27k.
C/R 23740
NJA 28-9-93

ISSUE 7
REFER SHT 2 & 3.

ISSUE 8
REFER SHT 2

ISSUE 9
C/R 24596
REFER SHT 2
5-6-96 MJS

ISSUE 10
C/R 24881
C8 DELETED.
R1 WAS 330R, R3
& R7 WERE 220R,
R32 & R35 WERE
270R. IC1, IC2
IC8 & IC9 WERE
SL640C. T3 & T4
WERE 44-70451
MIXERS LAYOUT
CHANGED.
C103-C111 ADDED
D13 & D14 ADDED,
R78-R81 ADDED.
REFER SHT 2.
7-1-97 MJS

ISSUE 11
R62 WAS 6K8 (E8)
R10 WAS 10 (F1)
C/R 25142
25-09-97 BCL

ISSUE 12
C/R 25166
E1 REPLACED WITH
XTAL QVEN ASSY
08-05235-001.
PCB WAS ISS -09
C/R 25951
04-4-3-99

ISSUE 13
D1-D4 WERE B8609A
D8 WAS B8405B
U14 & U15 WERE
B5D213
PCB WAS ISS -09
C/R 25951
04-4-3-99

ISSUE 14:
REFER SHT 3
C/R 26775

CODAN		SCALE		DATE	
DRN		I.T.		9-8-91	
CHKD		NJA		3-7-92	
APPD		NJA		30-7-92	
FINISH		TOLERANCES UNLESS OTHERWISE STATED		ISS	
		2 PLACE DEC. ±		11 12 13 14	
		1 PLACE DEC. ±			
		ANGULAR ±			
TITLE Rx/EXCITER & CONTROL (RF & DUAL SYNTHESISER)				DRAWING/DOC. NO 04-02907	
PCB 07-01623-10 ASSY 08-04840-001				SHT 1 OF 3	

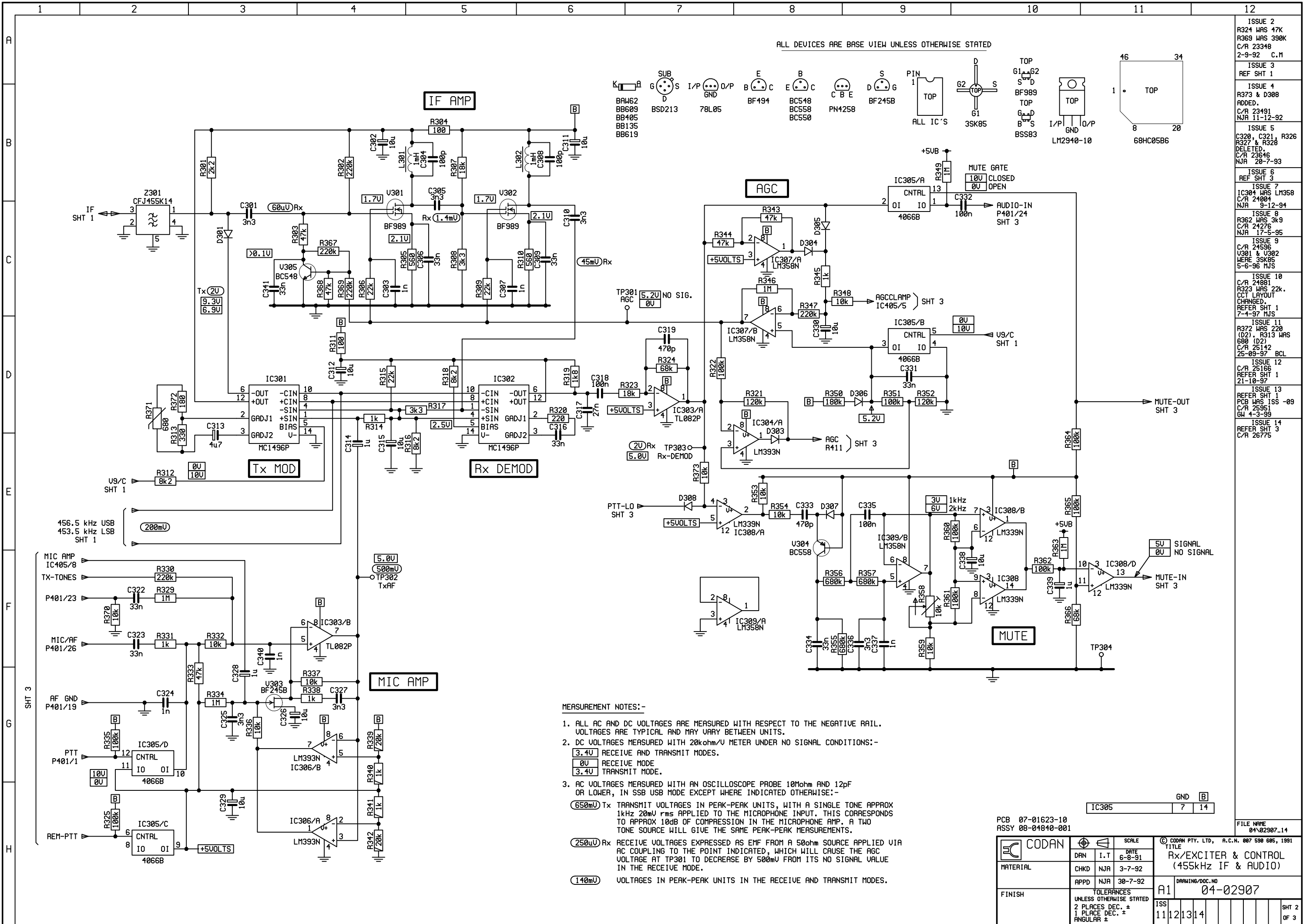

ALL DEVICES ARE BASE VIEW UNLESS OTHERWISE STATED

- K B
- G S
- I/P O/P
- B C
- E C
- C B E
- D G
- PIN 1
- D S
- TOP 62
- G1 S
- TOP 1
- I/P GND
- O/P 8
- LM2940-10
- 68HC0586

ISSUE 2
R324 WAS 17K
R369 WAS 390K
C/R 23348
2-9-92 C.M

ISSUE 3
REF SHT 1

ISSUE 4
R373 & D388
ADDED.
C/R 23491
NJA 11-12-92

ISSUE 5
C320, C321, R326
R327 & R328
DELETED.
C/R 23646
NJA 20-7-93

ISSUE 6
REF SHT 3

ISSUE 7
IC304 WAS LM358
C/R 24004
NJA 9-12-94

ISSUE 8
R362 WAS 3k9
C/R 24276
NJA 17-5-95

ISSUE 9
U301 & U302
WERE 3SK85
5-6-96 NJS

ISSUE 10
C/R 24881
R323 WAS 22k.
CCT LAYOUT
CHANGED.
REFER SHT 1
7-4-97 NJS

ISSUE 11
R372 WAS 220
(D21, R313 WAS
680 (D2)
C/R 25142
25-09-97 BCL

ISSUE 12
C/R 25166
REFER SHT 1
21-10-97

ISSUE 13
PCB WAS ISS -09
C/R 25951
04-4-3-99

ISSUE 14
REFER SHT 3
C/R 26775

MEASUREMENT NOTES:-

1. ALL AC AND DC VOLTAGES ARE MEASURED WITH RESPECT TO THE NEGATIVE RAIL. VOLTAGES ARE TYPICAL AND MAY VARY BETWEEN UNITS.
2. DC VOLTAGES MEASURED WITH 20kohm/V METER UNDER NO SIGNAL CONDITIONS:-

3.4V	RECEIVE AND TRANSMIT MODES.
0V	RECEIVE MODE
3.4V	TRANSMIT MODE.
3. AC VOLTAGES MEASURED WITH AN OSCILLOSCOPE PROBE 10Mohm AND 12pF OR LOWER, IN SSB USB MODE EXCEPT WHERE INDICATED OTHERWISE:-

650mV	Tx TRANSMIT VOLTAGES IN PEAK-PEAK UNITS, WITH A SINGLE TONE APPROX 1kHz 20mV rms APPLIED TO THE MICROPHONE INPUT. THIS CORRESPONDS TO APPROX 10dB OF COMPRESSION IN THE MICROPHONE AMP. A TWO TONE SOURCE WILL GIVE THE SAME PEAK-PEAK MEASUREMENTS.
250uV	Rx RECEIVE VOLTAGES EXPRESSED AS EMF FROM A 50ohm SOURCE APPLIED VIA AC COUPLING TO THE POINT INDICATED, WHICH WILL CAUSE THE AGC VOLTAGE AT TP301 TO DECREASE BY 500mV FROM ITS NO SIGNAL VALUE IN THE RECEIVE MODE.
140mV	VOLTAGES IN PEAK-PEAK UNITS IN THE RECEIVE AND TRANSMIT MODES.

PCB 07-01623-10
ASSY 08-04840-001

	DRN	I.T.	SCALE	© CODAN PTY. LTD., A.C.N. 007 590 605, 1991 Rx/EXCITER & CONTROL (455kHz IF & AUDIO)
	CHKD	NJA	DATE 3-7-92	
FINISH	APPD	NJA	30-7-92	DRAWING/DOC. NO A1 04-02907
TOLERANCES UNLESS OTHERWISE STATED 2 PLACES DEC. ± 1 PLACE DEC. ± ANGULAR ±				ISS 11 12 13 14

FILE NAME
04-02907-14

SHT 2
OF 3

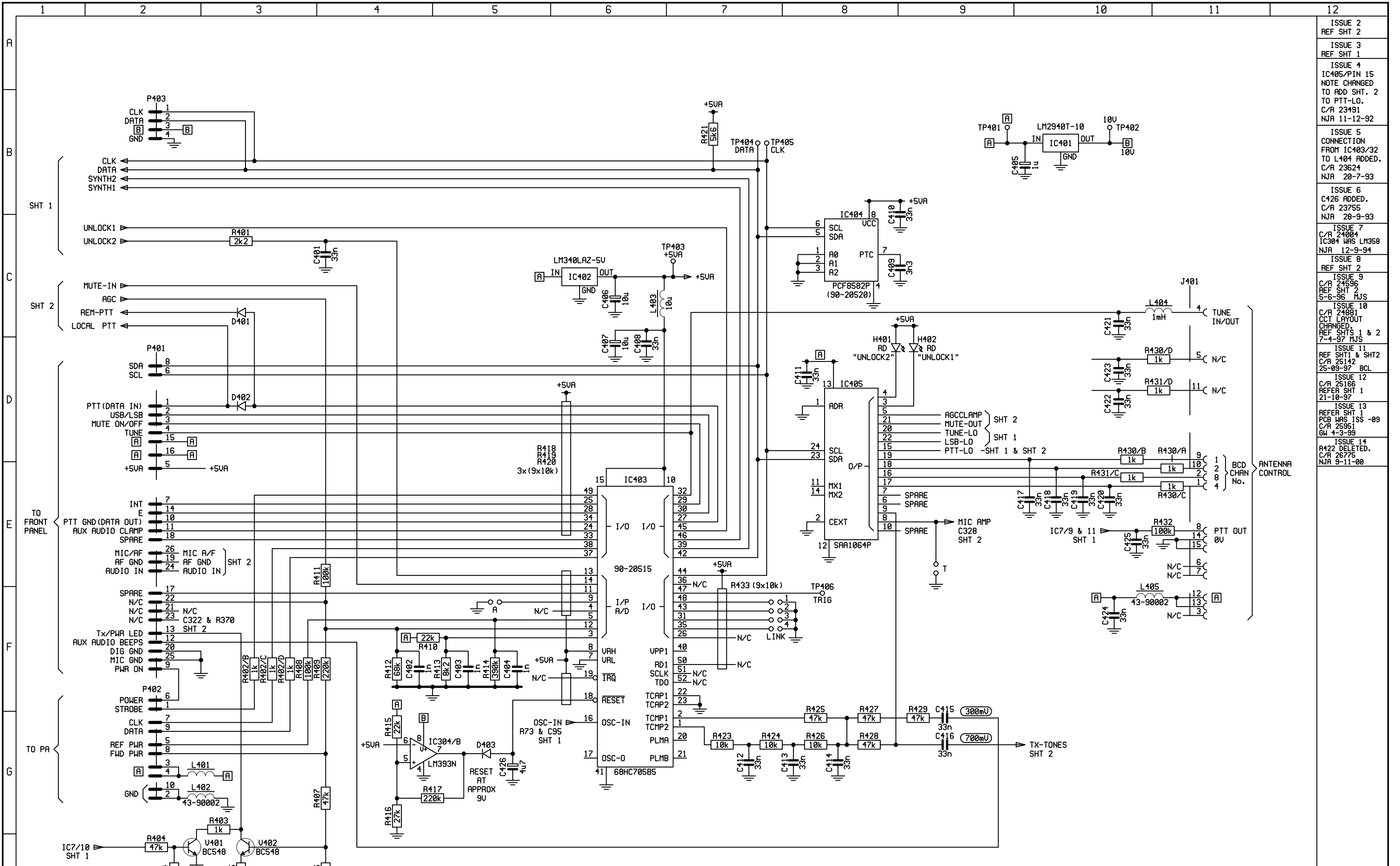

ISSUE 2
REF SHT 2

ISSUE 3
REF SHT 1

ISSUE 4
IC405/PIN 15
NOTE CHANGED
TO ADD SHT. 2
TO PTT-LO.
C/R 23491
NJA 11-12-92

ISSUE 5
CONNECTION
FROM IC403/32
TO L404 ADDED.
C/R 23624
NJA 28-7-93

ISSUE 6
C426 ADDED.
C/R 23755
NJA 28-9-93

ISSUE 7
C/R 24004
IC304 WAS LM358
NJA 12-9-94

ISSUE 8
REF SHT 2

ISSUE 9
REF SHT 2

ISSUE 10
C/R 24881
C/T LAYOUT
CHANGED.
REF SHTS 1 & 2
7-4-97 MJS

ISSUE 11
REF SHT1 & SHT2
C/R 25142
25-09-97 BCL

ISSUE 12
C/R 25166
REFER SHT 1
21-10-97

ISSUE 13
REFER SHT 1
PCB WAS ISS -09
C/R 25951
GW 4-3-99

ISSUE 14
R422 DELETED.
C/R 26775
NJA 9-11-00

NOTES:-
1. REFER SHEET 2 FOR PIN OUTS.

PCB 07-01623-10
ASSY 08-04840-001

CODAN		SCALE	© CODAN PTY. LTD., A.C.N. 007 590 605, 1991	
MATERIAL		DRN	I.T.	DATE
FINISH		CHKD	NJA	3-7-92
		APPD	NJA	30-7-92
		DRAWING/DOC. NO.		
		A2		04-02907
		ISS		11 12 13 14
		SHT 3		OF 3

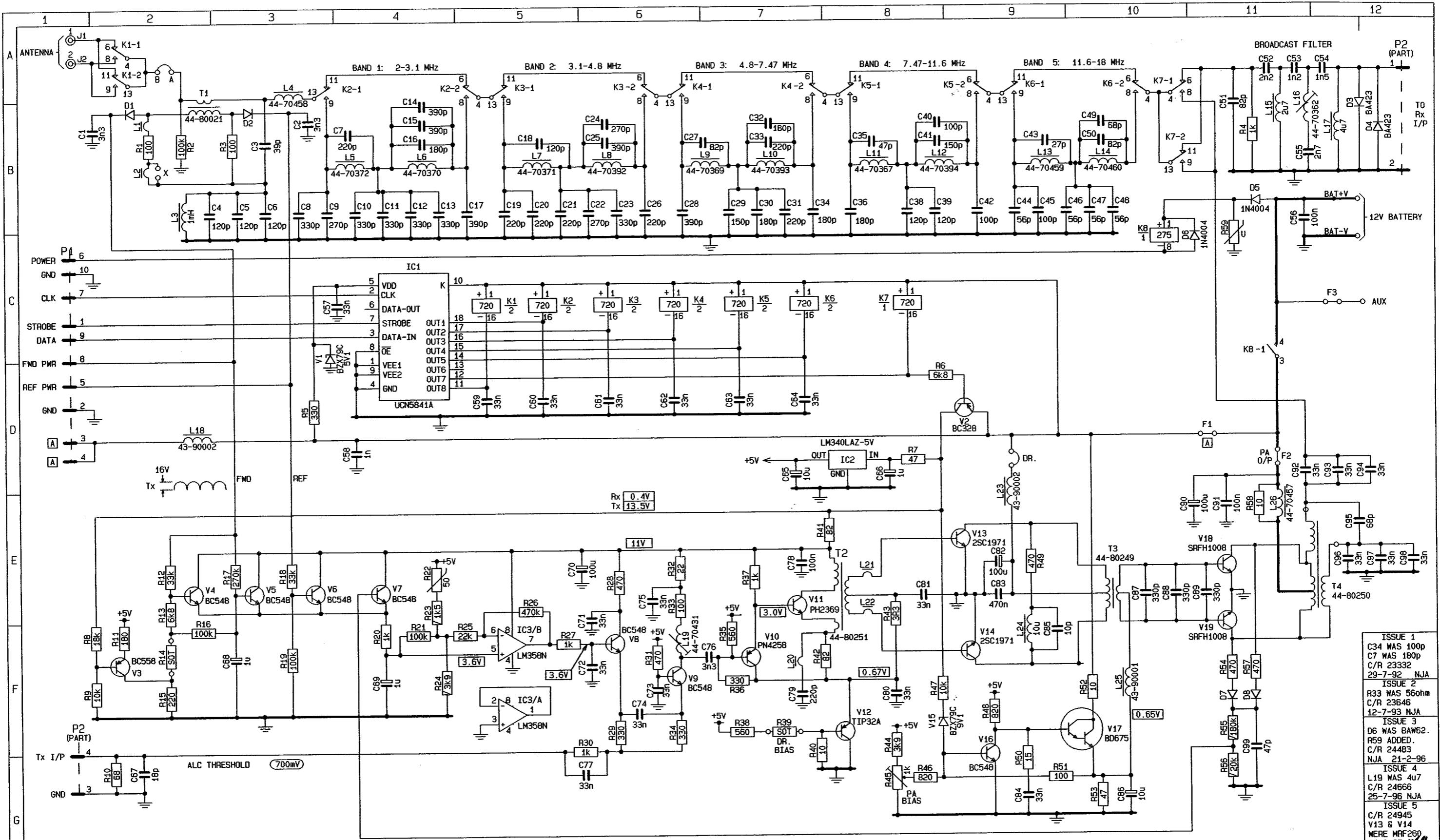

- MEASUREMENT NOTES:-**
1. ALL VOLTAGES ARE MEASURED WITH RESPECT TO THE NEGATIVE RAIL. VOLTAGES ARE TYPICAL AND MAY VARY BETWEEN UNITS.
 2. DC VOLTAGES SHOWN [3.4V] ARE MEASURED WITH A 20kohm/V METER, & ARE IN THE TRANSIT MODE & WITHOUT SIGNALS APPLIED.
 3. USE AN EARTH AS CLOSE AS PRACTICABLE TO POINT OF MEASUREMENT. WIND EXCESS PROBE EARTH LEAD AROUND PROBE TO MINIMISE LOOP AREA.
 4. ALL MEASUREMENTS ARE MADE WITH A DC SUPPLY OF 13.6V & 100M PEP O/P.
 5. DC VOLTAGES SHOWN Tx [3.4V] AND WAVEFORMS ARE MEASURED WITH 100M PEP TWO TONE OUTPUT.

ALL DEVICES ARE BASE VIEW UNLESS OTHERWISE STATED

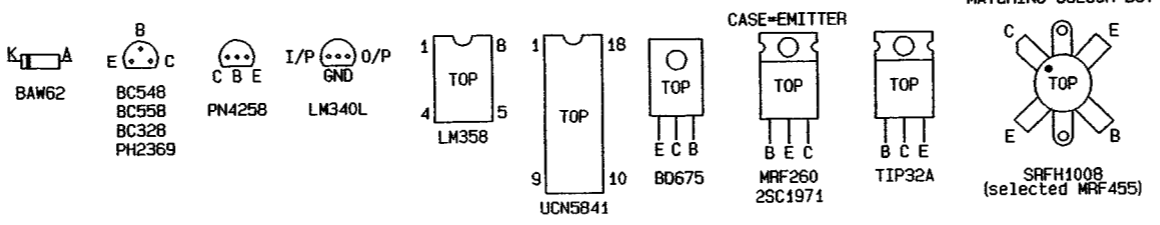

- NOTES:**
1. DIODES ARE BAW62, OR EQUIVALENT, UNLESS OTHERWISE STATED.
 2. RESISTORS SHOWN [] ARE 2% TOLERANCE.

ISSUE 1
C34 WAS 100p
C7 WAS 180p
C/R 23332
29-7-92 NJA

ISSUE 2
R33 WAS 56ohm
C/R 23646
12-7-93 NJA

ISSUE 3
D6 WAS BAW62.
R59 ADDED.
C/R 24483
NJA 21-2-96

ISSUE 4
L19 WAS 4u7
C/R 24666
25-7-96 NJA

ISSUE 5
C/R 24945
V13 & V14
WERE MRF260
25-3-97

CODAN		SCALE	TITLE	
DRN	C 6	DATE	PA & FILTER	
CHKD	NJA	3-7-92	DRAWING/DOC NO	
APPD	NJA	3-7-92	A1 04-02908	
FINISH		TOLERANCES	ISS	
UNLESS OTHERWISE STATED		2 PLACES DEC. ±	1 2 3 4 5	
1 PLACE DEC. ±		ANGULAR ±	SHT 1	
OF 1				

PCB 07-01624
ASSY 08-04841-001

MASTER IF NOT IN RED CHECK STATUS

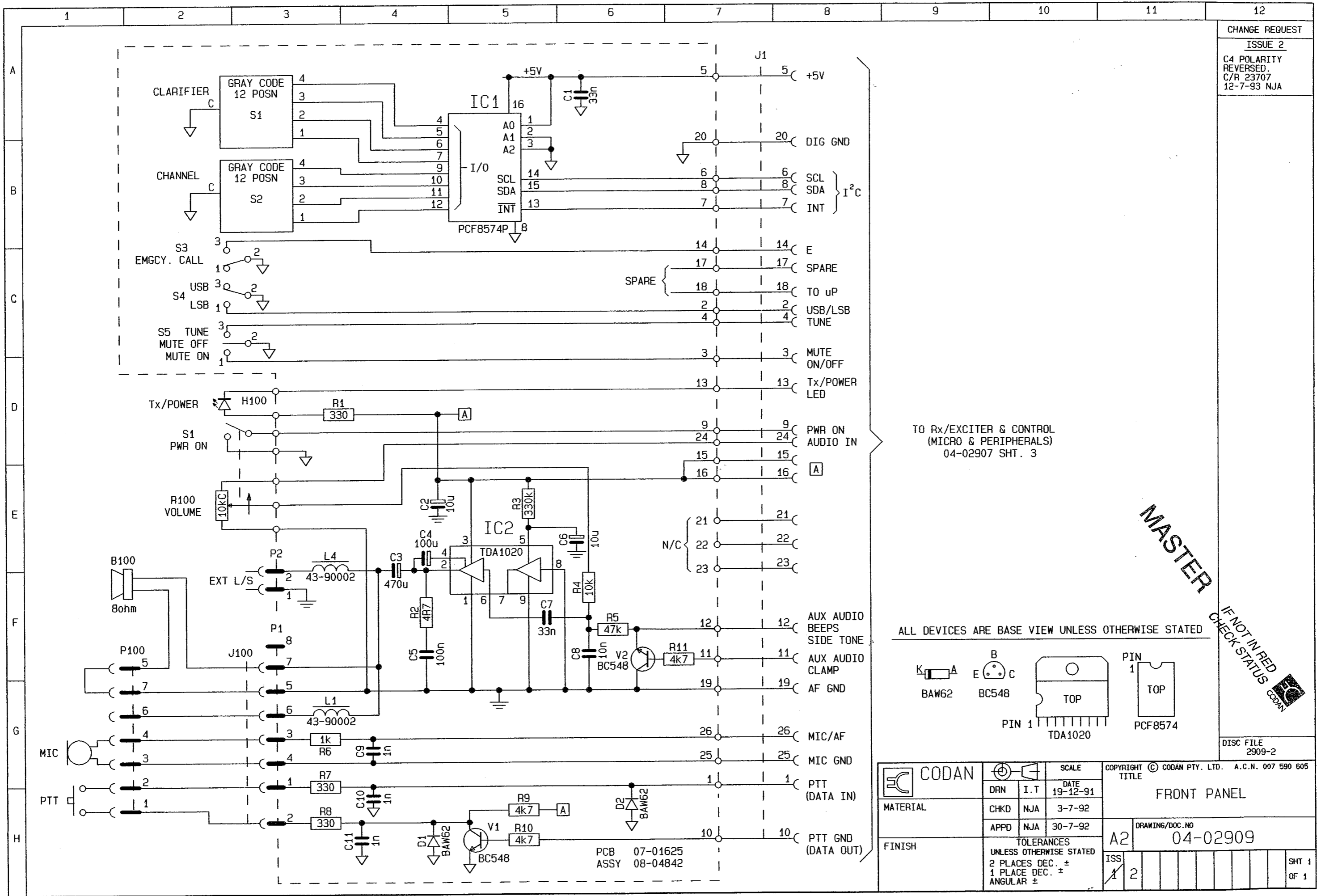

CHANGE REQUEST
 ISSUE 2
 C4 POLARITY REVERSED.
 C/R 23707
 12-7-93 NJA

TO Rx/EXCITER & CONTROL (MICRO & PERIPHERALS)
 04-02907 SHT. 3

MASTER

IF NOT IN RED CHECK STATUS

ALL DEVICES ARE BASE VIEW UNLESS OTHERWISE STATED

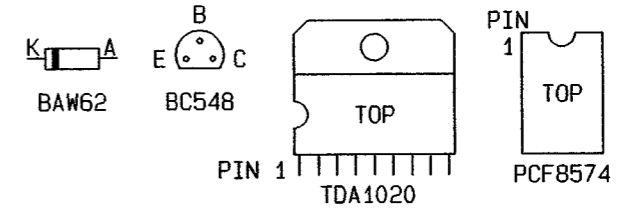

CODAN	DRN	I.T	SCALE	COPYRIGHT © CODAN PTY. LTD. A.C.N. 007 590 605	
	CHKD	NJA	DATE 19-12-91	TITLE	
MATERIAL	APPD	NJA	30-7-92	FRONT PANEL	
FINISH	TOLERANCES UNLESS OTHERWISE STATED			DRAWING/DOC. NO	
	2 PLACES DEC. ± 1 PLACE DEC. ± ANGULAR ±			A2 04-02909	
ISS 1/2			SHT 1 OF 1		

DISC FILE 2909-2

CHANGE REQUEST

ISSUE B
U1 WAS BCX20.
NOTE: CHGED.
C/R 24530
22-05-96 NJA

ISSUE 2
R9 WAS 270K
R1 WAS 4K7
R15, U3 ADDED
C/R 24987
04-07-97 MJS

ISSUE 3
RENUMBERED
R3,R8,R9,R10
R11 WERE 1206
R7 WAS 220
TABLE ADDED.
C/R 25721
09-11-98 RRU

ISSUE 4
PCB WAS ISS -03
C/R 26392
GDD 21/12/99

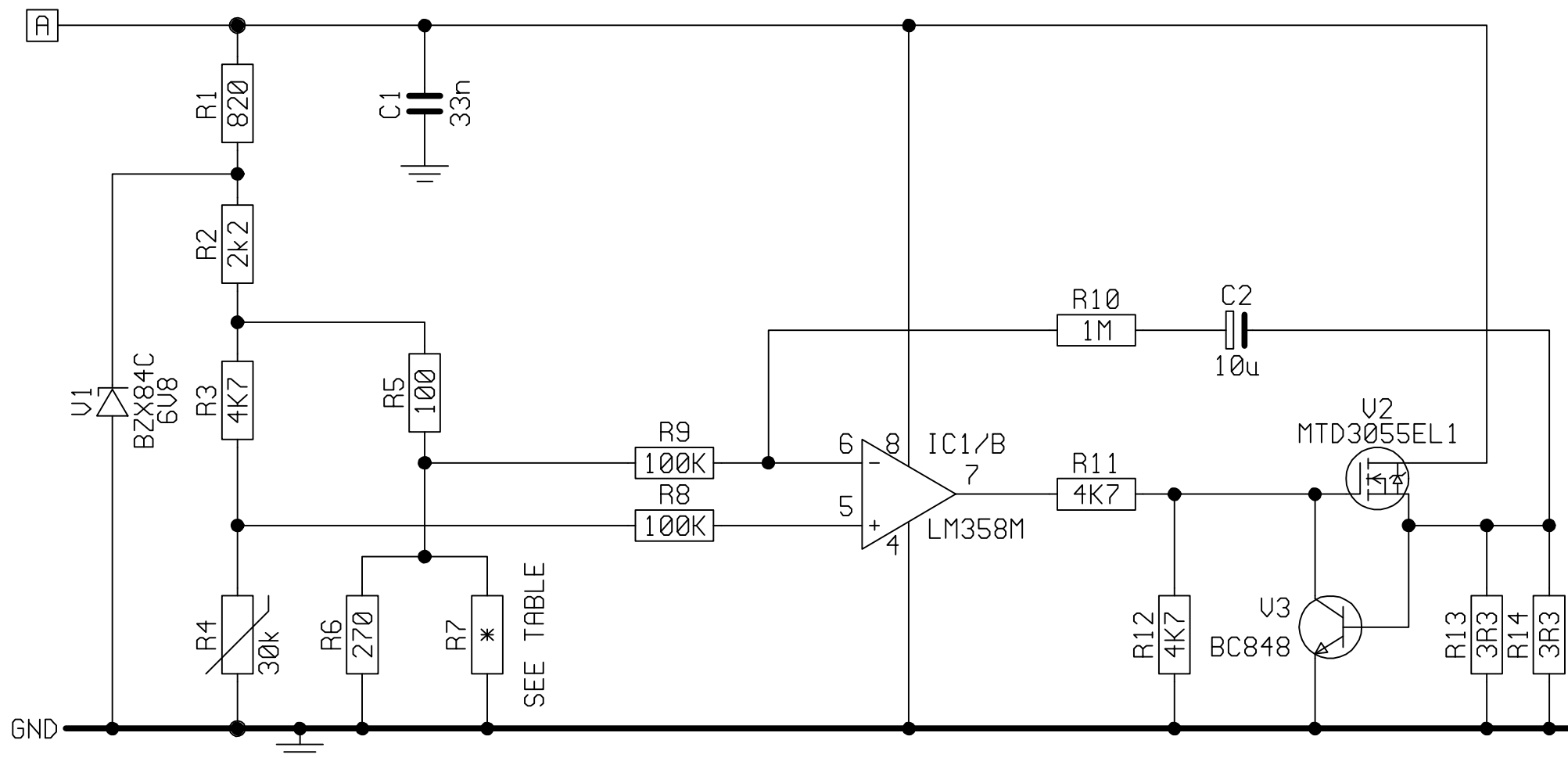

VERSION	R7
08-05235-001	220
08-05235-002	150

ALL DEVICES ARE VIEWED FROM THE TOP

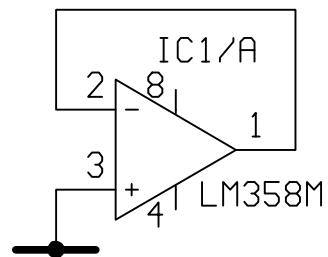
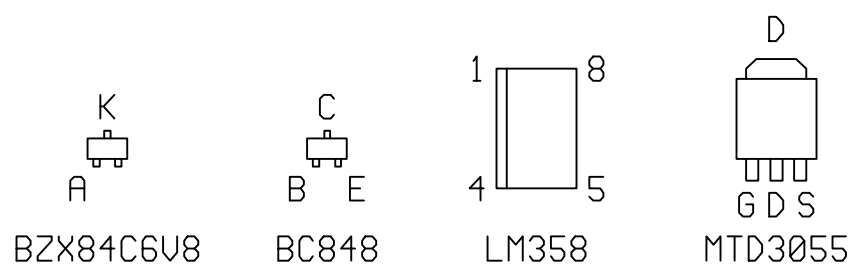

PCB 07-01732-04

			SCALE	© CODAN PTY. LTD, A.C.N. 007 590 605, 1995	
	DRA	AML	DATE	TITLE	
MATERIAL	CHKD	NJA	08-02-96	CRYSTAL OVEN	
FINISH	APPD	NJA	04-10-96	DRAWING/DOC.NO	
TOLERANCES UNLESS OTHERWISE STATED			A3	04-03095	
2 PLACES DEC. ± 1 PLACE DEC. ± ANGULAR ±				ISS	SHT 1 OF 1

FILE NAME
04\03095_4

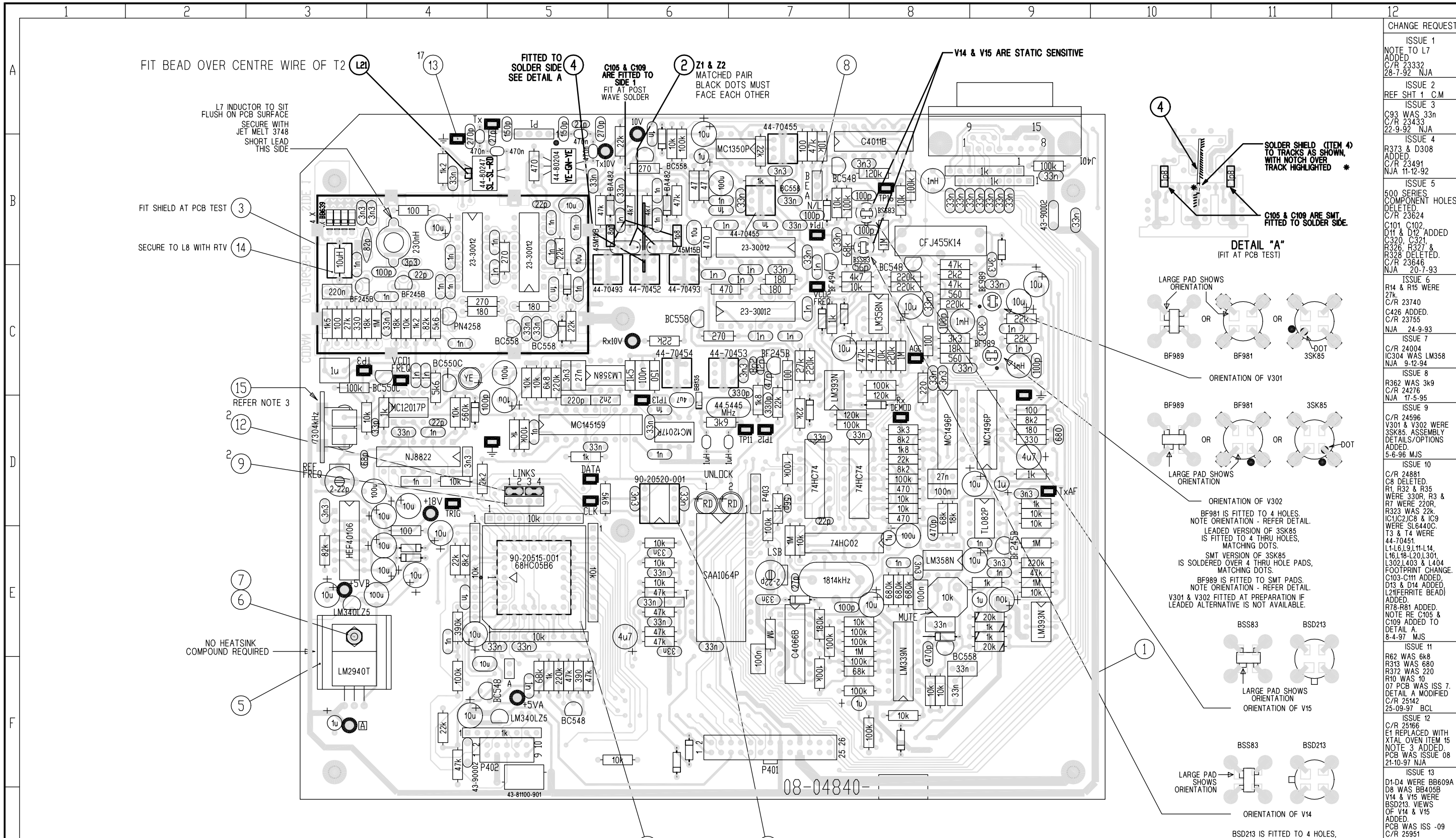

FIT BEAD OVER CENTRE WIRE OF T2 (L21)

L7 INDUCTOR TO SIT FLUSH ON PCB SURFACE SECURE WITH JET MELT 3748 SHORT LEAD THIS SIDE

FIT SHIELD AT PCB TEST (3)

SECURE TO L8 WITH RTV (14)

REFER NOTE 3 (15)

(12)

(9)

(7)

(6)

NO HEATSINK COMPOUND REQUIRED

(5)

FITTED TO SOLDER SIDE SEE DETAIL A (4)

C105 & C109 ARE FITTED TO SIDE FIT AT POST WAVE SOLDER

Z1 & Z2 MATCHED PAIR BLACK DOTS MUST FACE EACH OTHER (2)

V14 & V15 ARE STATIC SENSITIVE (8)

SOLDER SHIELD (ITEM 4) TO TRACKS AS SHOWN, WITH NOTCH OVER TRACK HIGHLIGHTED *
C105 & C109 ARE SMT FITTED TO SOLDER SIDE.

DETAIL "A"
(FIT AT PCB TEST)

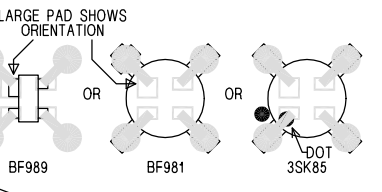

ORIENTATION OF V301

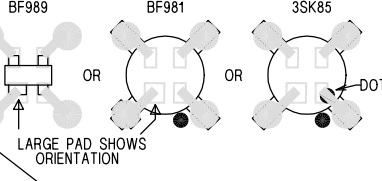

ORIENTATION OF V302

BF981 IS FITTED TO 4 HOLES. NOTE ORIENTATION - REFER DETAIL. LEADED VERSION OF 3SK85 IS FITTED TO 4 THRU HOLES, MATCHING DOTS. SMT VERSION OF 3SK85 IS SOLDERED OVER 4 THRU HOLE PADS, MATCHING DOTS. BF989 IS FITTED TO SMT PADS. NOTE ORIENTATION - REFER DETAIL. V301 & V302 FITTED AT PREPARATION IF LEADED ALTERNATIVE IS NOT AVAILABLE.

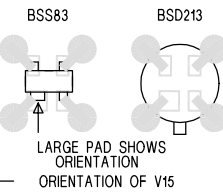

ORIENTATION OF V15

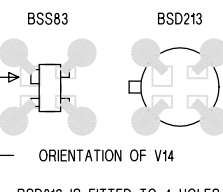

ORIENTATION OF V14

BSD213 IS FITTED TO 4 HOLES, BEND EACH LEAD OUTWARDS 0.5mm TO FIT. NOTE ORIENTATION - REFER DETAIL. BSS83 IS FITTED TO SMT PADS. NOTE ORIENTATION - REFER DETAIL. V14 & V15 FITTED AT PREPARATION IF LEADED ALTERNATIVE IS NOT AVAILABLE.

- NOTES:-**
1. THESE RESISTORS ARE 2% TOLERANCE.
 2. ALL DIODES ARE BAW62 OR EQUIVALENT UNLESS OTHERWISE STATED.
 3. TO FIT CRYSTAL OVEN ASSEMBLY:
 - A. APPLY ONE LAYER OF KAPTON TAPE (ITEM 16) TO THE TOP OF CRYSTAL(Z3). DO NOT COVER SIDES.
 - B. APPLY THERMA FLOW COMPOUND TO THE TEMPERATURE SENSOR(R3) AND THE TOP AND SIDES OF THE CRYSTAL, THEN SLIDE INTO OVEN ASSY(ITEM 15). ENSURE THE CRYSTAL IS NOT LOOSE IN THE METAL CLIP AND THE TOP OF CRYSTAL IS TOUCHING THE TEMPERATURE SENSOR.
 - C. FIT THE OVEN & CRYSTAL ASSY ON TO PCB AND SOLDER.

PCB 07-01623-10
ASSY P/No. 08-04840-001

CODAN		SCALE 2:1	CODAN PTY LTD A.C.N.007 590 605. 1992	
DRN. NJA	I.T.	DATE 8-4-92	RECEIVER/EXCITER ASSEMBLY	
CHKD. NJA	APPR. NJA	DATE 17-6-92	DRAWING/DWG. No. 08-04840	
FINISH		TOLERANCES UNLESS OTHERWISE STATED	ISS 11 12 13 14 SHT 1 OF 2	
		2 PLACES DEC		
		1 PLACE DEC		
		ANGULAR		

CHANGE REQUEST

ISSUE 1
NOTE TO L7 ADDED
C/R 23332
28-7-92 NJA

ISSUE 2
REF SHT 1 C.M

ISSUE 3
C93 WAS 33n
C/R 23433
22-9-92 NJA

ISSUE 4
R373 & D308 ADDED
C/R 23491
NJ 11-12-92

ISSUE 5
500 SERIES COMPONENT HOLES DELETED.
C/R 23624
C101, C102, D11 & D12 ADDED
C320, C321, R326, R327 & R328 DELETED.
C/R 23646
NJ 20-7-93

ISSUE 6
R14 & R15 WERE 27k.
C/R 23740
C426 ADDED.
C/R 23755
NJ 24-9-93

ISSUE 7
C/R 24004
IC304 WAS LM358
NJ 9-12-94

ISSUE 8
R362 WAS 3k9
C/R 24276
NJ 17-5-95

ISSUE 9
C/R 24596
V301 & V302 WERE 3SK85. ASSEMBLY DETAILS/OPTIONS ADDED.
5-6-96 MJS

ISSUE 10
C/R 24881
C8 DELETED.
R1, R32 & R35 WERE 330R, R3 & R7 WERE 220R, R23 WAS 22k, IC1, IC2, IC8 & IC9 WERE SL6440C. T3 & T4 WERE 44-70451, L1-L6, L9, L11-L14, L16-L18-L20-L30, L302, L403 & L404 FOOTPRINT CHANGE. C103-C111 ADDED. D13 & D14 ADDED. L21(FERRITE BEAD) ADDED.
R78-R81 ADDED.
NOTE RE C105 & C109 ADDED TO DETAIL A.
8-4-97 MJS

ISSUE 11
R62 WAS 6k8
R313 WAS 680
R372 WAS 220
R10 WAS 10
07 PCB WAS ISS 7. DETAIL A MODIFIED
C/R 25142
25-09-97 BCL

ISSUE 12
C/R 25166
E1 REPLACED WITH XTAL OVEN ITEM 15
NOTE 3 ADDED.
PCB WAS ISSUE 08
21-10-97 NJA

ISSUE 13
D1-D4 WERE BB609A
D8 WAS BB405B
V14 & V15 WERE BSD213. VIEWS OF V14 & V15 ADDED.
PCB WAS ISS -09
C/R 25951
GW 4-3-99

ISSUE 14
R422 DELETED
C/R26775
NJ 9-11-00

FILE NAME
07\01623_10

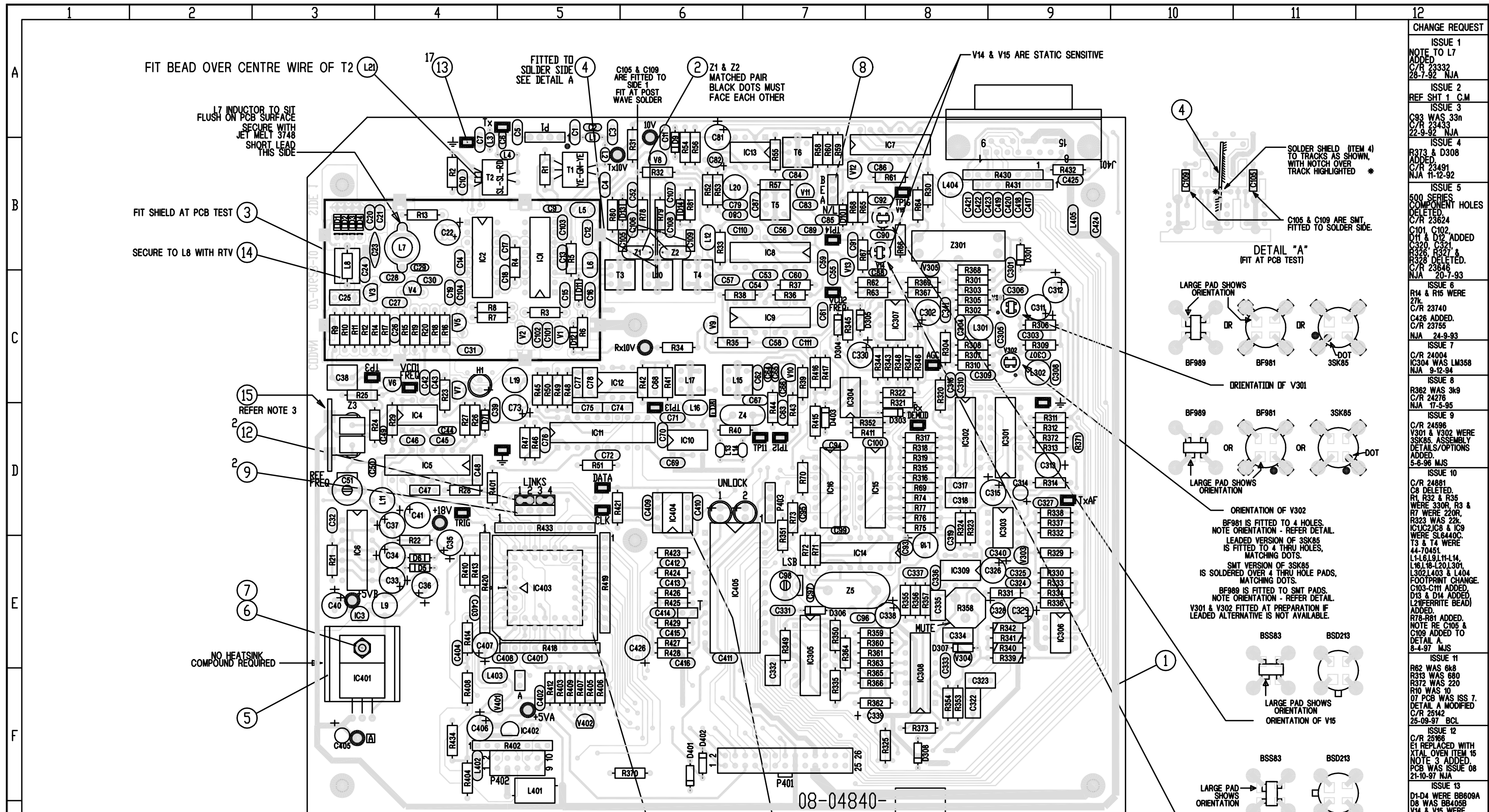

- NOTES:-
- THESE RESISTORS ARE 2% TOLERANCE.
 - ALL DIODES ARE BAW62 OR EQUIVALENT UNLESS OTHERWISE STATED.
 - TO FIT CRYSTAL OVEN ASSEMBLY:
 - APPLY ONE LAYER OF KAPTON TAPE (ITEM 16) TO THE TOP OF CRYSTALIZ3. DO NOT COVER SIDES.
 - APPLY THERMA FLOW COMPOUND TO THE TEMPERATURE SENSOR(R3) AND THE TOP AND SIDES OF THE CRYSTAL, THEN SLIDE INTO OVEN ASSY(ITEM 15). ENSURE THE CRYSTAL IS NOT LOOSE IN THE METAL CLIP AND THE TOP OF CRYSTAL IS TOUCHING THE TEMPERATURE SENSOR.
 - FIT THE OVEN & CRYSTAL ASSY ON TO PCB AND SOLDER.

PCB 07-01623-10
ASSY P/No. 08-04840-001

CODAN		SCALE 2:1	© CODAN PTY LTD ACMA07 590 605 1992	
DRN	I.T	DATE 8-4-92	RECEIVER/EXCITER ASSEMBLY	
CHKD	NJA	17-6-92	DRAWING/DOC NO. 08-04840	
APPD	NJA	30-7-92	ISS 11 12 13 14	
FINISH		TOLERANCES UNLESS OTHERWISE STATED 2 PLACES DEC 1 PLACE DEC ANGULAR	SHT 2 OF 2	

CHANGE REQUEST

ISSUE 1
NOTE TO L7
ADDED
C/R 23332
28-7-92 NJA

ISSUE 2
REF SHT 1 C.M

ISSUE 3
C83 WAS 33n
C/R 23433
22-9-92 NJA

ISSUE 4
R373 & D308
ADDED
C/R 23491
NJA 11-12-92

ISSUE 5
500 SERIES
COMPONENT HOLES
LETED
C/R 23624
C101, C102,
D11 & D12 ADDED
C320, C321,
R326, R327 &
R328 DELETED.
C/R 23646
NJA 20-7-93

ISSUE 6
R14 & R15 WERE
27k
C/R 23740
C426 ADDED.
C/R 23755
NJA 24-9-93

ISSUE 7
C/R 24004
IC304 WAS LM358
NJA 9-12-94

ISSUE 8
R362 WAS 3k9
C/R 24276
NJA 17-5-95

ISSUE 9
C/R 24596
V301 & V302 WERE
3SK85. ASSEMBLY
DETAILS/OPTIONS
ADDED.
5-8-96 MJS

ISSUE 10
C/R 24881
C8 DELETED.
R1 R32 & R35
WERE 330R. R3 &
R7 WERE 220R.
R323 WAS 22k.
IC1, IC2, IC8 & IC9
WERE SL6440C.
T3 & T4 WERE
44-70A51.
L1-L6, L11-L14,
L16-L18, L20, L301,
L302, L403 & L404
FOOTPRINT CHANGE.
C103-C111 ADDED.
D13 & D14 ADDED.
L21/FERRITE BEAD)
ADDED.
R78-R61 ADDED.
NOTE RE C105 &
C109 ADDED TO
DETAIL A.
8-4-97 MJS

ISSUE 11
R62 WAS 6k8
R313 WAS 680
R372 WAS 220
R10 WAS 10
07 PCB WAS ISS 7.
DETAIL A MODIFIED
C/R 25142
25-09-97 BCL

ISSUE 12
C/R 25166
E1 REPLACED WITH
XTAL OVEN ITEM 15
NOTE 3 ADDED.
PCB WAS ISSUE 08
21-10-97 NJA

ISSUE 13
D1-D4 WERE BB609A
D8 WAS BB405B
V14 & V15 WERE
BSD213. VIEWS
OF V14 & V15
ADDED.
PCB WAS ISS -09
C/R 25951
GW 4-3-99

ISSUE 14
R422 DELETED
C/R26776
NJA 9-11-00

FILE NAME
07\01623_10

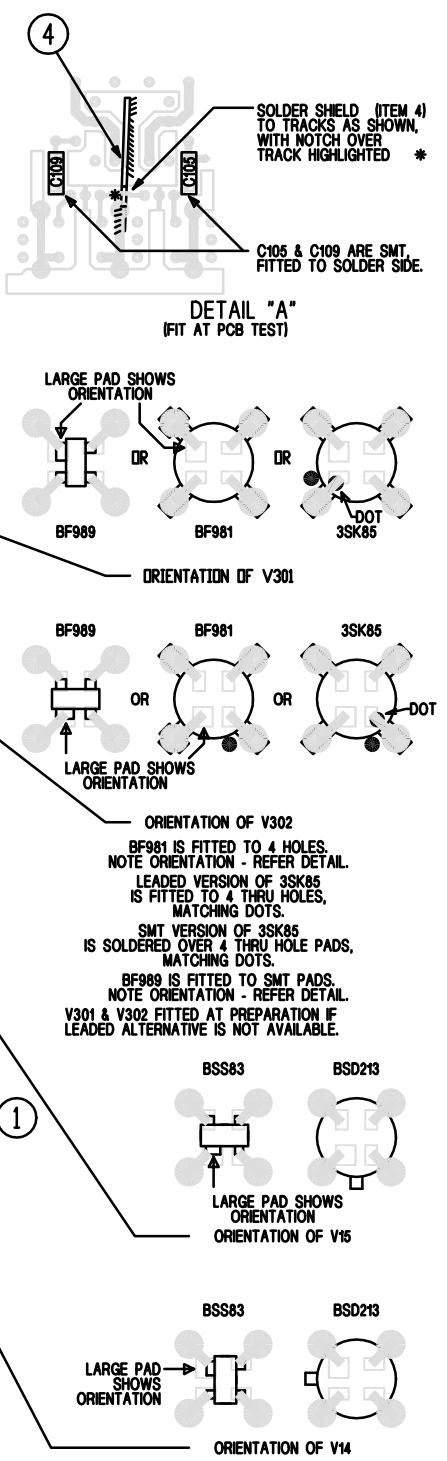

DO NOT SCALE

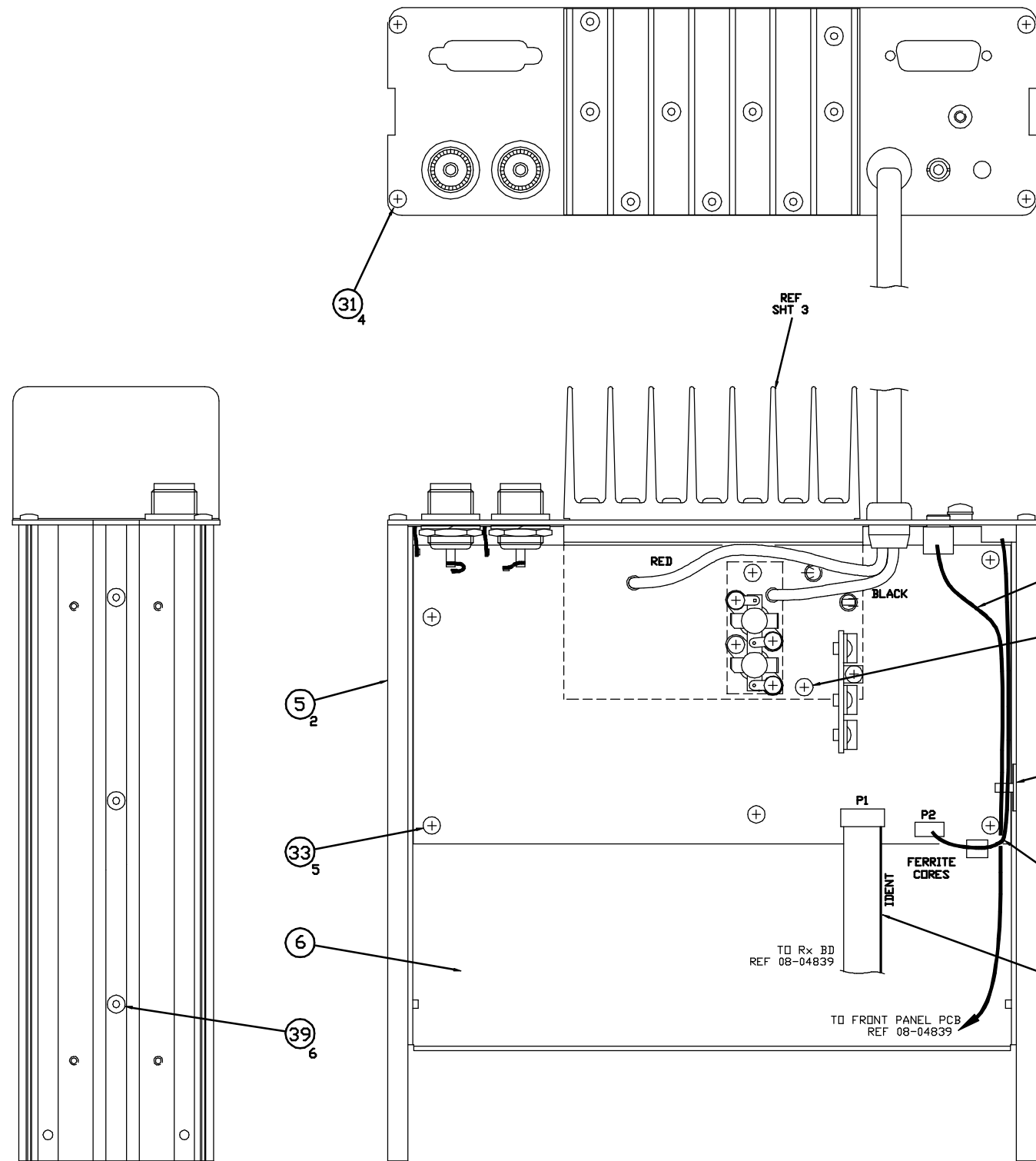

BOTTOM VIEW

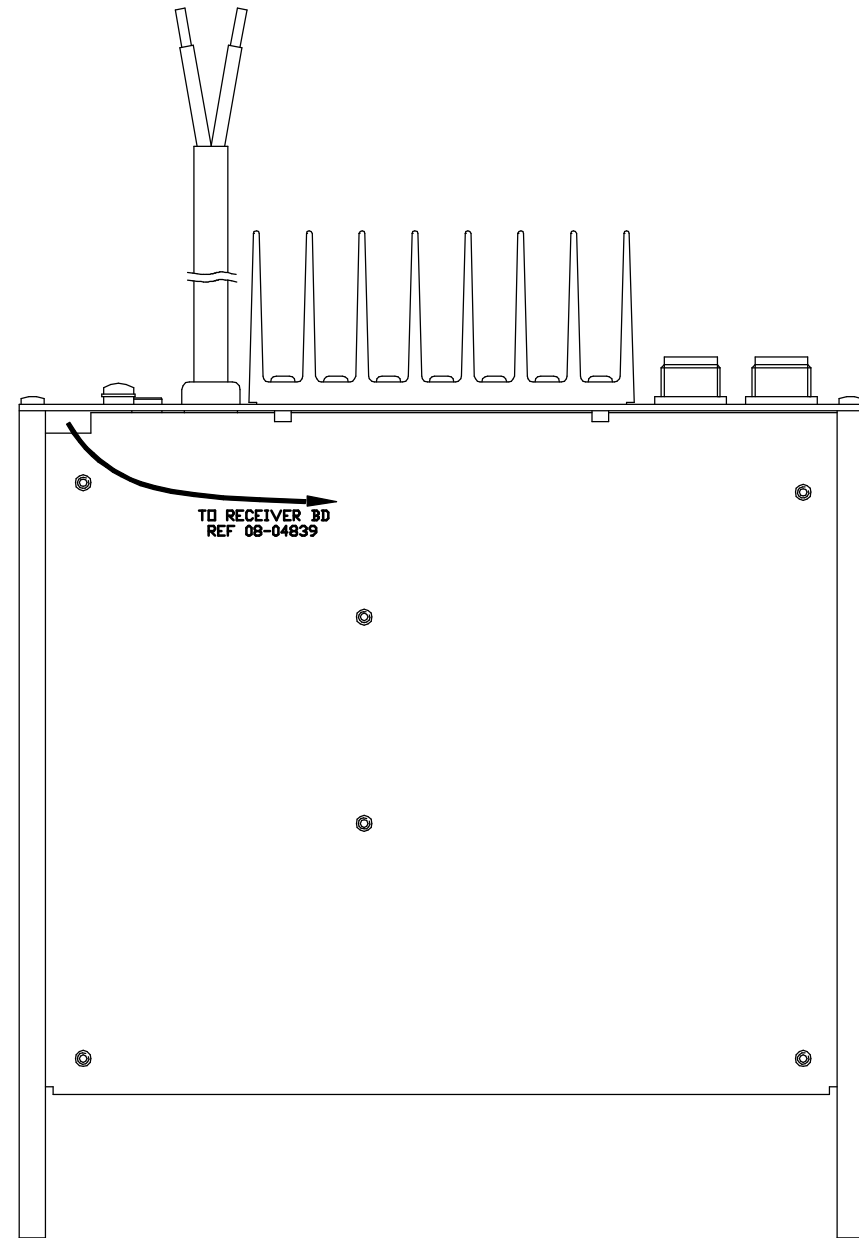

TOP VIEW

ISSUE B
REF SHTS 2 & 4
ISSUE C
ITEMS 37 & 38
DELETED.
C/R 23320
15-07-92 RFW
ISSUE 1
REF SHTS 2-5
ISSUE 2
REF SHT 5
ISSUE 3
REF SHTS 2-5
ISSUE 4
REF SHT 2
ISSUE 5
REF SHTS 2-5
ISSUE 6
REF SHTS 2-5
ISSUE 7
REDRAWN ACAD
TSM NOW
SHT 1 OF 1.
REF SHTS 1-4
ISSUE 8
CR 24945
PCB WAS ISSUE 6
REFER SHTS 1-4
24-3-97 NJA
ISSUE 9
REFER TO SHEET 2
ISSUE 10
REFER TO SHEET 1
ISSUE 11
SHTS 5&6 ADDED.
C/R 25477
3-7-98 VS

FILE No.
08\04841A11.DWG

	SCALE	1:1	© CODAN PTY LTD, A.C.N. 007 590 605. 1996 TITLE PA & CHASSIS ASSEMBLY
	DRN	DB	
MATERIAL	CHKD	RFW	25-05-92
FINISH	APPD	NJA	10-07-92
	TOLERANCES UNLESS OTHERWISE STATED		A1 08-04841 ISS 11 SHT. 1 OF 6
2 PLACES DEC. ±0.25			
1 PLACE DEC. ±0.5			
0 PLACE DEC. ±1			
ANGULAR ±2°			

DIMENSIONS IN mm

DO NOT SCALE

ISSUE 11
 SHTS 5&6 ADDED
 C/R 25477
 3-7-98 VS

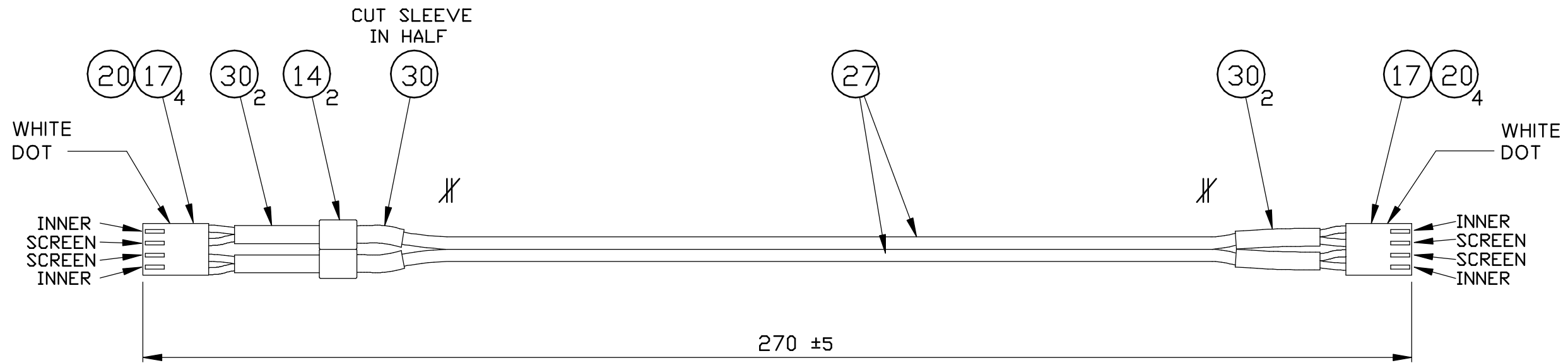

1. TERMINATE EACH SCREEN BRAID WITH 25.0 BLACK WIRE (ITEM 25)

FILE No.
 08\04841A11.DWG

DIMENSIONS IN mm

			SCALE 1:1	© CODAN PTY LTD, A.C.N. 007 590 605: 1998			
	DRN	DB	DATE 26-6-98	TITLE PA & CHASSIS ASSY DETAIL A			
MATERIAL	CHKD			DRAWING/DOC NO.			
FINISH	APPD			A3			
	TOLERANCES UNLESS OTHERWISE STATED			08-04841			
				ISS			
				11			SHT. 5 OF 6

DO NOT SCALE

ISSUE 11
 SHTS 5&6 ADDED.
 C/R 25477
 3-7-98 VS

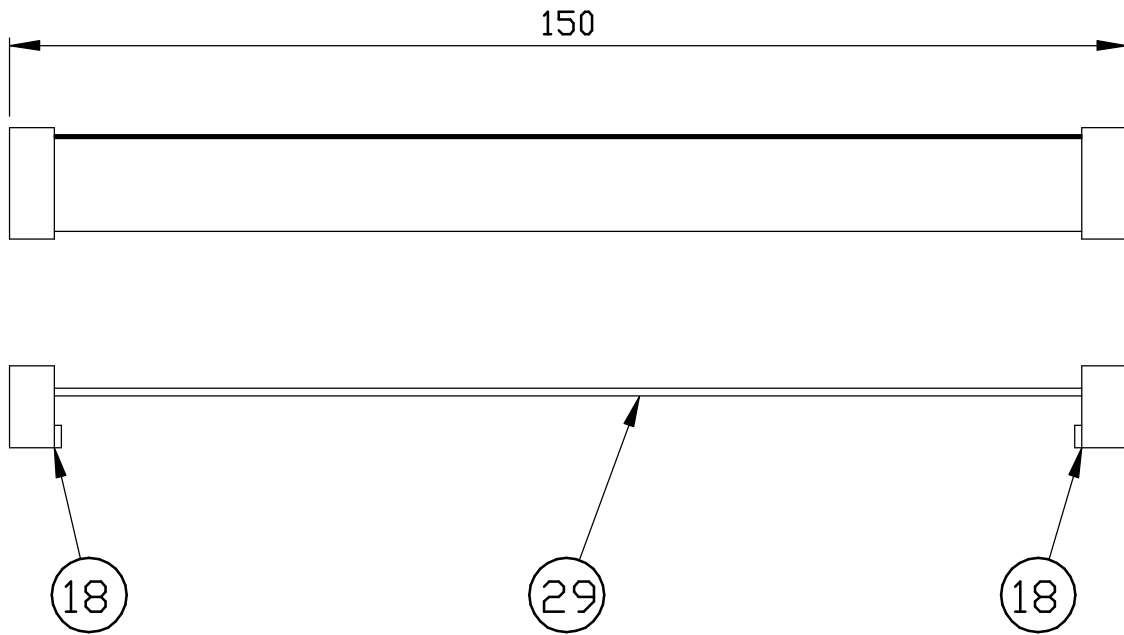

DIMENSIONS IN mm FILE No. 08\04841A11.DWG

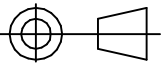
 CODAN			SCALE 1:1	© CODAN PTY LTD, A.C.N. 007 590 605: 1998	
	DRN	DB	DATE 26-6-98	TITLE PA & CHASSIS ASSY DETAIL B	
MATERIAL	CHKD			DRAWING/DOC NO. 08-04841	
FINISH	APPD			A4	ISS 11
	TOLERANCES UNLESS OTHERWISE STATED 2 PLACES DEC. ±0.25 1 PLACE DEC. ±0.5 0 PLACE DEC. ±1 ANGULAR ±2°				

A
B
C
D
E
F
G
H

'KINK' FUSE WIRE UP 10mm

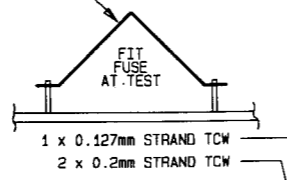

INDUCTORS

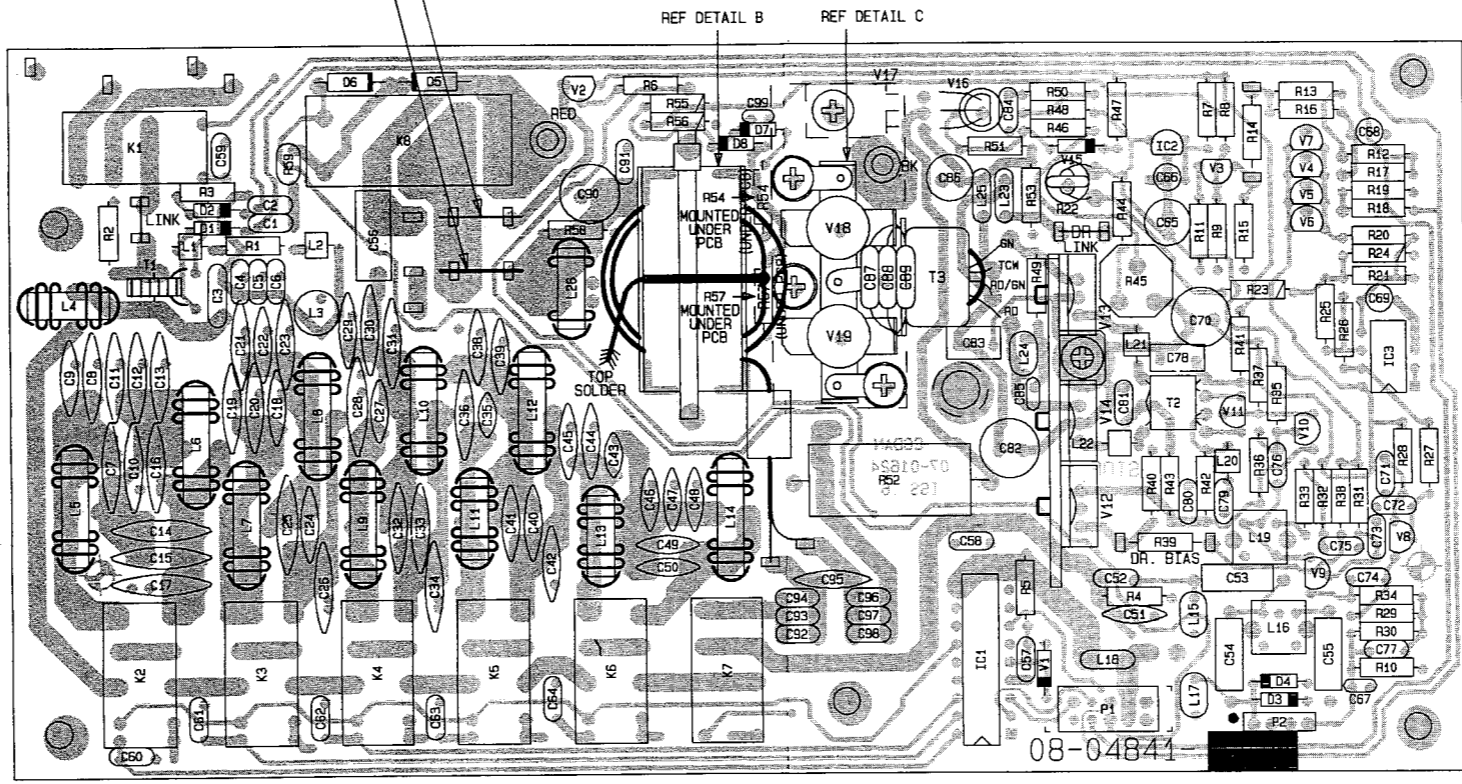
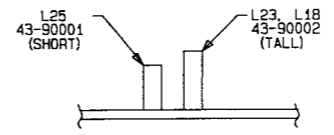

CONNECT BRAID AND ENAMELLED WIRES TO TRANSISTOR TABS. KEEP LEADS SHORT AS POSSIBLE

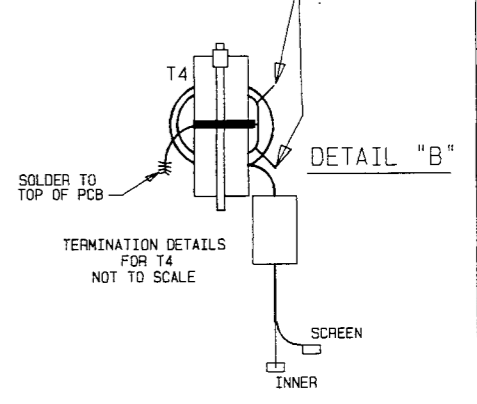

BEND 2 TABS UP 90 deg 1.5mm FROM ENDS. (BOTH TRANSISTORS) AS SHOWN.

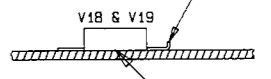

NOTE: COAT UNDERSIDE OF V18 & V19 WITH THERMA FLOW COMPOUND BEFORE ASSEMBLY.

DETAIL "C"

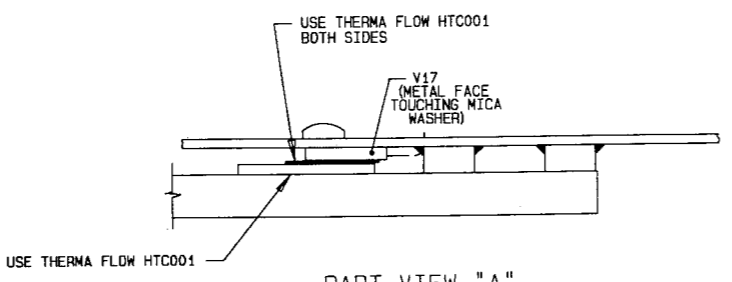

PART VIEW "A"
SHOWING ASSEMBLY OF HEATSINK TO PCB

VIEW A

- NOTES:
1. ALL LINKS ARE 22 SWG.
 2. FIT STRAP BEFORE T4 IS SOLDERED TO PCB.
 3. RESISTORS SHOWN ARE 2%

CHANGE REQUEST	
ISSUE B	C37 DELETED
	C44 WAS 100p
	C95 WAS 100p
	C/R 23355
	3/7/92 NJA
ISSUE C	ITEM 45 ADDED
	C/R 23320
	15/7/92 NJA
ISSUE 1	C34 WAS 100p
	C7 WAS 180p
	C/R 23332
	29/7/92 NJA
ISSUE 2	WIRE 01A WAS
	3 x 0.127mm
	C/R 23497
	L4 WAS
	GN GN OR
	C/R 23522
	23-2-93 NJA
ISSUE 3	R33 WAS 56ohm
	C/R 23646
	12/7/93 NJA
ISSUE 4	NOTES 4 & 5
	ADDED ON SHT 2
	C/R 23675
	C.M. 9-8-93
ISSUE 5	D6 WAS
	23-10001
	R59 ADDED
	C/R 24483
	C.M. 21-2-96
ISSUE 6	C/R 24666
	L3, L15, L17, L19
	6 L24 WERE 5mm
	5 PITCH
	L19 WAS 4u7
	ITEM 42 DELETED
	PCB WAS ISS. 4
	26-7-95 NJA
ISSUE 7	C/R 24832
	L24 ROTATED
	PCB WAS ISS. 5
	9-1-97 JB

PCB 07-01624 ISSUE 6
ASSY P/No. 08-04841-001

CODAN		SCALE 2:1	CODAN PTY LTD. A.C.N. 007 590 605. 1992	
DRN. P.J.L.	DATE 22-4-92	PA & FILTER PCB ASSEMBLY		
CHKD. NJA	DATE 26-5-92	DRAWING/DOC No. 08-04841		
APPD. NJA	DATE 30-7-92	ISS 1		
UNLESS OTHERWISE STATED		SHT 1 OF 1		
2 PLACES DEC ±	3 PLACES DEC ±			
ANGULAR ±				

FILE NAME 07\01624_5.PCB

DO NOT SCALE

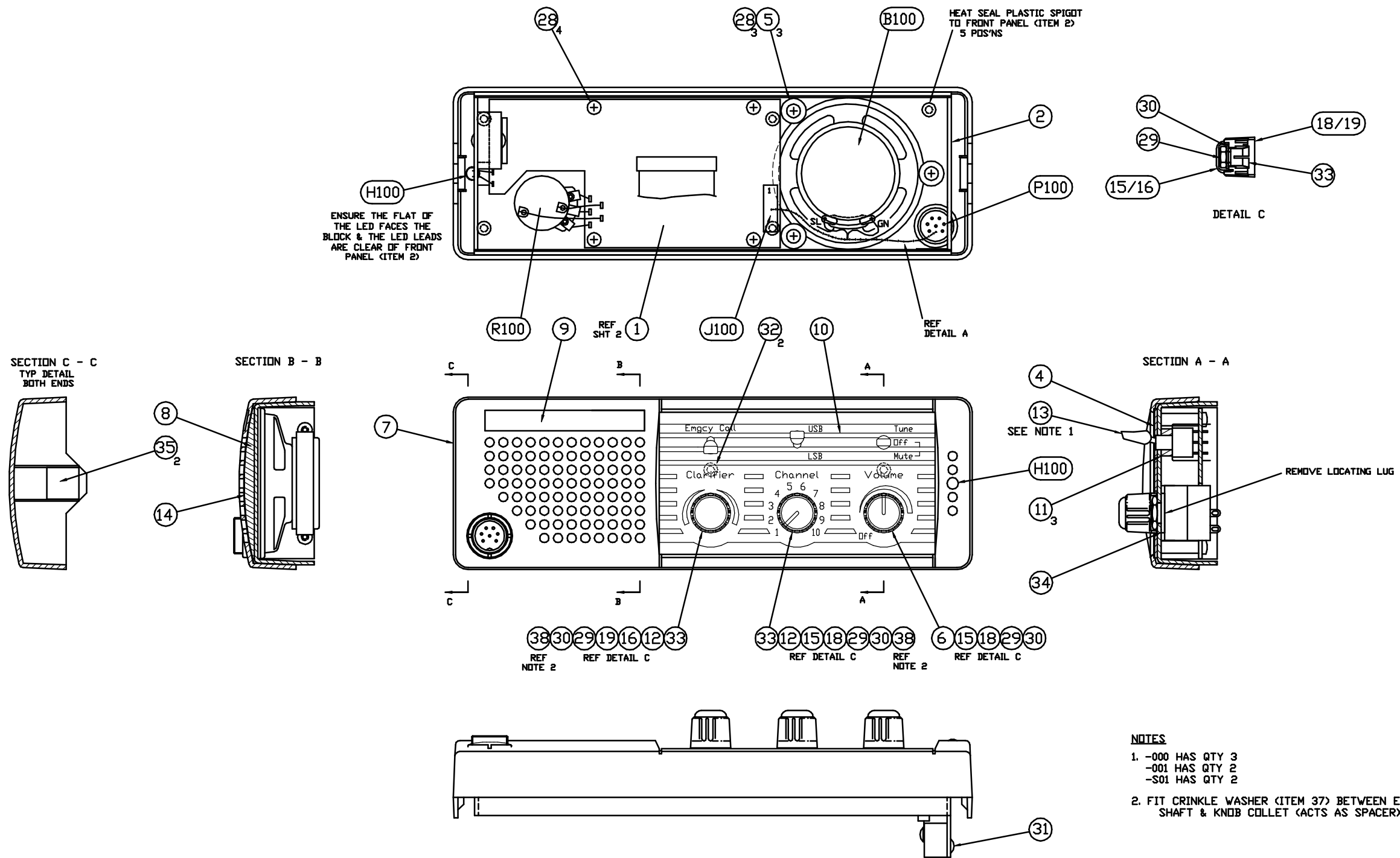

- NOTES**
- 000 HAS QTY 3
-001 HAS QTY 2
-S01 HAS QTY 2
 - FIT CRINKLE WASHER (ITEM 37) BETWEEN END OF SHAFT & KNOB COLLET (ACTS AS SPACER).

08-04842-000	SHT 1	STANDARD BUILD
08-04842-001	SHT 3	ICRC BUILD
08-04842-S01	SHT 4	SMC BUILD

REMOVE BURRS & SHARP EDGES

CODAN	SCALE	1:1	© CODAN PTY LTD, A.C.N. 007 590 605. 1997
	DATE	04-02-92	
MATERIAL	DRN	DB	TITLE
	CHKD	RFW	
FINISH	APPD	NJA	DRAWING/DOC NO.
	TOLERANCES UNLESS OTHERWISE STATED		
2 PLACES DEC. ±0.25		ISS	8
1 PLACE DEC. ±0.5			
0 PLACE DEC. ±1		OF 5	
ANGULAR ±2°			

DIMENSIONS IN mm

ISSUE 8
ITEM 20 DELETED,
ITEM 35 ADDED,
ITEM 34 QTY WAS
4,
C/R 23320 RFW
15-7-92

ISSUE 2
ITEMS 6 & 35
DELETED. CM
16-10-92

ISSUE 3
SHT 4 ADDED.
C/R 23619

ISSUE 4
REF SHTS 2 & 3

ISSUE 5
TABLE AND NOTE 1
ADDED.
SHTS 2 & 3
COMBINED ON SHT2
C/R 24884
JFB 03-03-97

ISSUE 6
ITEM 37 & NOTE 2
ADDED.
-S01 IN TABLE WAS
-002
C/R 24999
23-05-97 BAB

ISSUE 7
SHT 5 ADDED,
NOTE ADDED TO H100,
LOAD TRANSFERRED
TO SHT 5.
C/R 25483
16-7-98 VS

ISSUE 8
REFER SHT 2

FILE No.
08\04842_8.DWG

DO NOT SCALE

ISSUE B
REF SHT1

ISSUE 2
REF SHT1

ISSUE 3
REF SHT4

ISSUE 4
C4 POLARITY
REVERSED.
C/R 23707
NJA 12-07-93

ISSUE 5
SMC BUILD STD
ADDED AS SHT4
C/R 24884

ISSUE 6
REFER SHT 1

ISSUE 7
SHT 5 ADDED,
REF SHT 1.

ISSUE 8
C2 WAS 100u
C/R 26130
VS 18-6-99

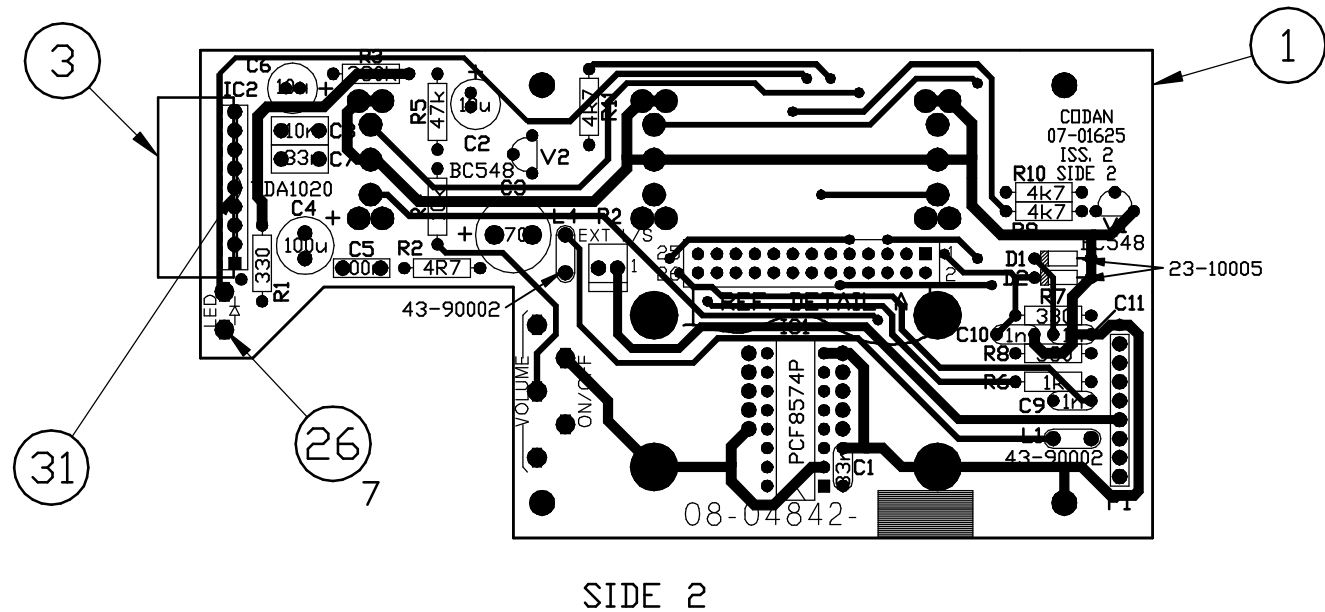

SIDE 2

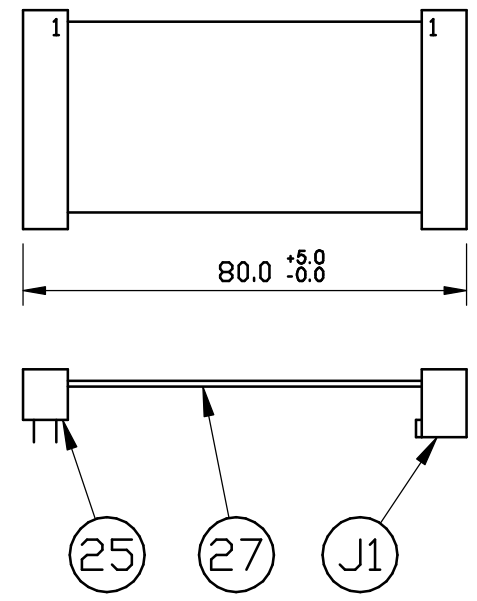

DETAIL A

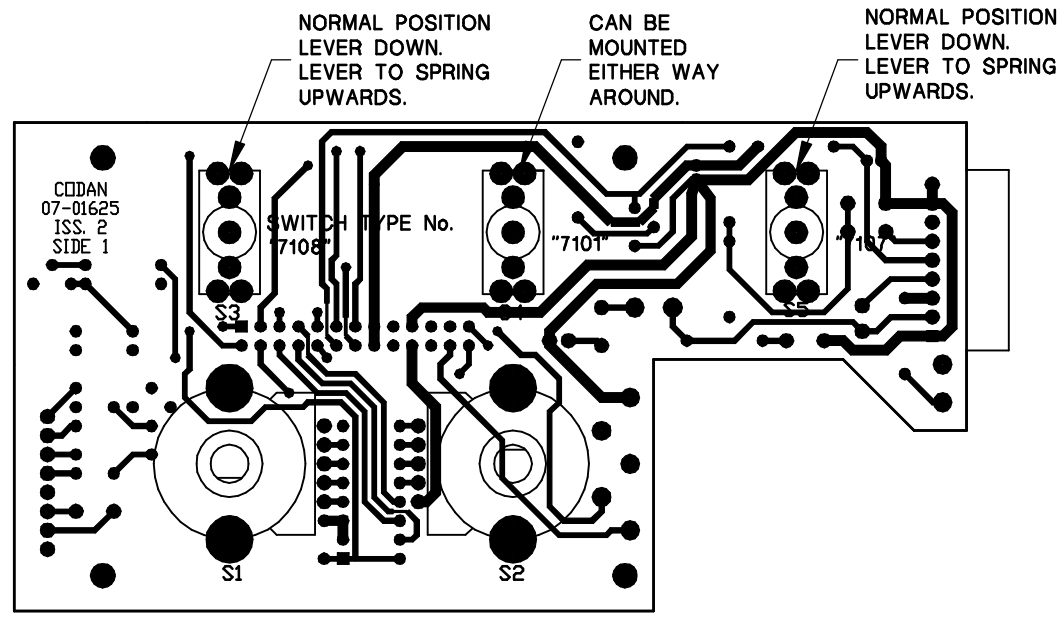

SIDE 1

PCB 07-01625 ISSUE 2
ASSY P/No 08-04842-000

FILE No.
08\04842_8.DWG

DIMENSIONS IN mm

			SCALE 2:1	© CODAN PTY LTD, A.C.N. 007 590 605: 1997 TITLE FRONT PANEL PCB ASSEMBLY					
	DRN	ILT	DATE 08-04-92	DRAWING/DOC NO. 08-04842					
MATERIAL	CHKD	NJA	26-05-92						
FINISH	APPD	NJA	30-07-92	A3					
	TOLERANCES UNLESS OTHERWISE STATED								
	2 PLACES DEC. ±0.25 1 PLACE DEC. ±0.5 0 PLACE DEC. ±1 ANGULAR ±2°								
			ISS 8						SHT. 2 OF 5

DO NOT SCALE

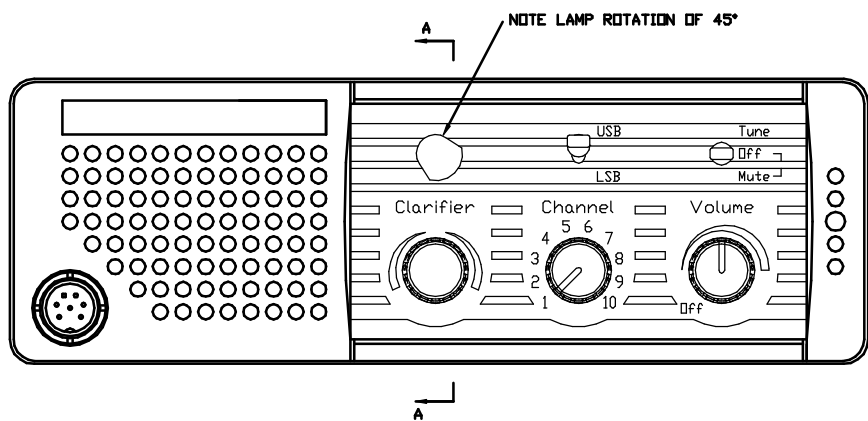
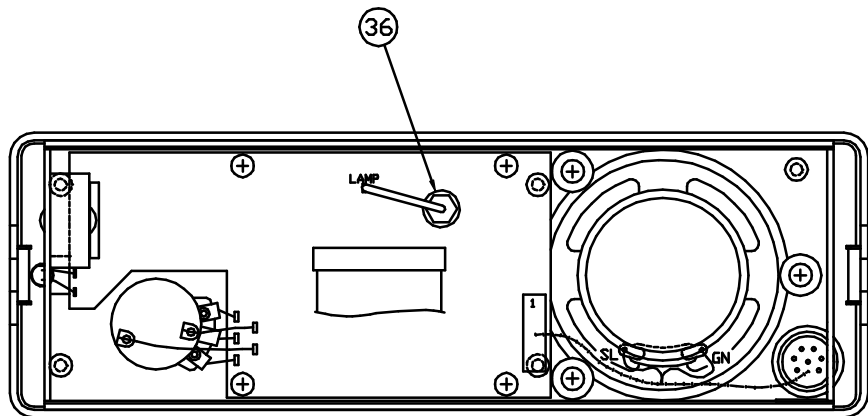

ALL OTHER DETAIL - REF SHT 1

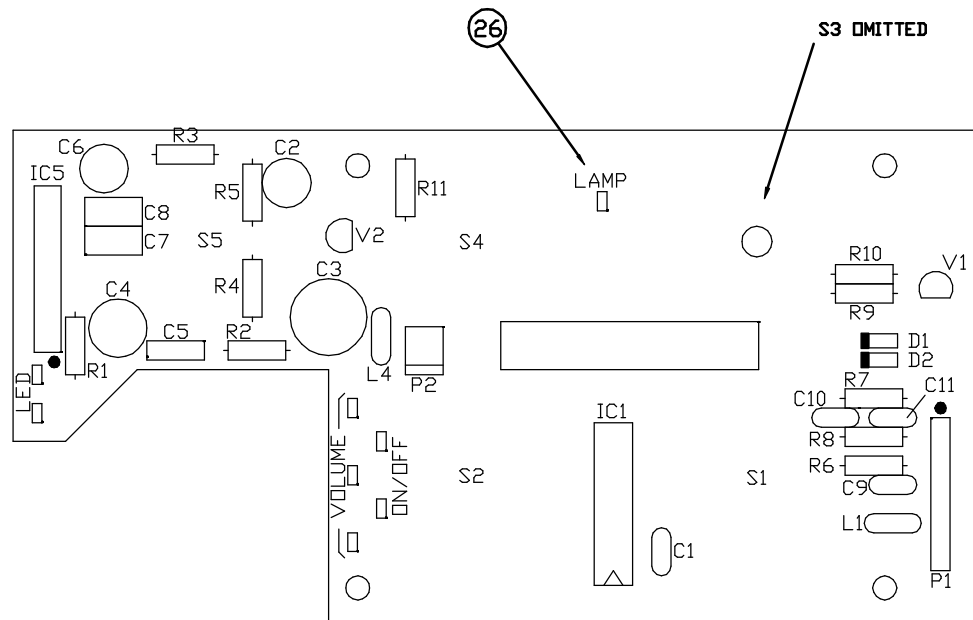
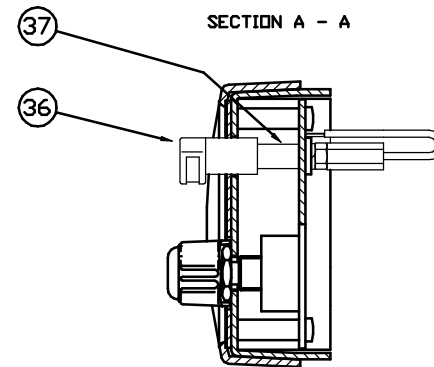

ALL OTHER DETAIL - REF SHTS 2 & 3
(SCALE 2:1)

ISSUE 8
ITEM 20 DELETED,
ITEM 35 ADDED,
ITEM 34 QTY WAS
4.
C/R 23320 RFV
15-7-92

ISSUE 2
ITEMS 6 & 35
DELETED. CM
16-10-92

ISSUE 3
SHT 4 ADDED.
ITEMS 36 & 37
ADDED.
C/R 23619 CM
24-3-93

ISSUE 4
REF SHTS 2 & 3

ISSUE 5
REF SHTS 1 & 4

ISSUE 6
REF SHT 1

ISSUE 7
SHT 5 ADDED,
REF SHT 1.

ISSUE 8
REFER SHT 2

FILE No.
08\04842_B.DWG

REMOVE BURRS & SHARP EDGES

	SCALE	1:1	© CODAN PTY LTD, A.C.N. 007 690 605: 1997 TITLE FRONT PANEL ASSY (X2) RED CROSS
	DRN	DB	
MATERIAL	CHKD	RFW	25-06-92
FINISH	APPD	NJA	30-07-92
	TOLERANCES UNLESS OTHERWISE STATED 2 PLACES DEC. ±0.25 1 PLACE DEC. ±0.5 0 PLACE DEC. ±1 ANGULAR ±2°		
A1		DRAWING/DOC NO. 08-04842	
ISS		8	
DIMENSIONS IN mm			SHT. 3 OF 5

DO NOT SCALE

ISSUE 5
REF SHT 1.
SNC BUILD SHT4
ADDED.
C/R 24884
JFB 03-03-97

ISSUE 6
REF SHT 1.

ISSUE 7
SHT 5 ADDED,
REF SHT 1.

ISSUE 8
REFER SHT 2

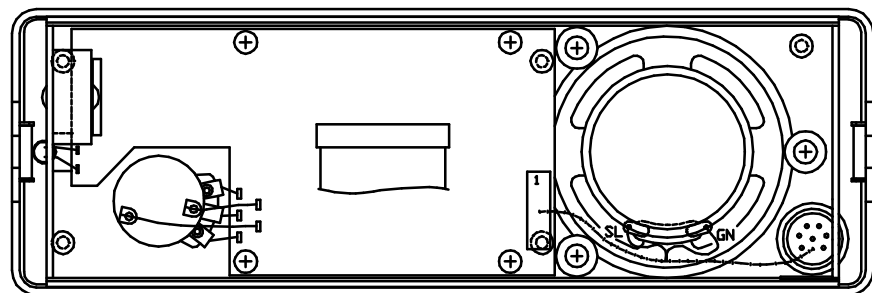

ALL OTHER DETAIL - REF SHT 1

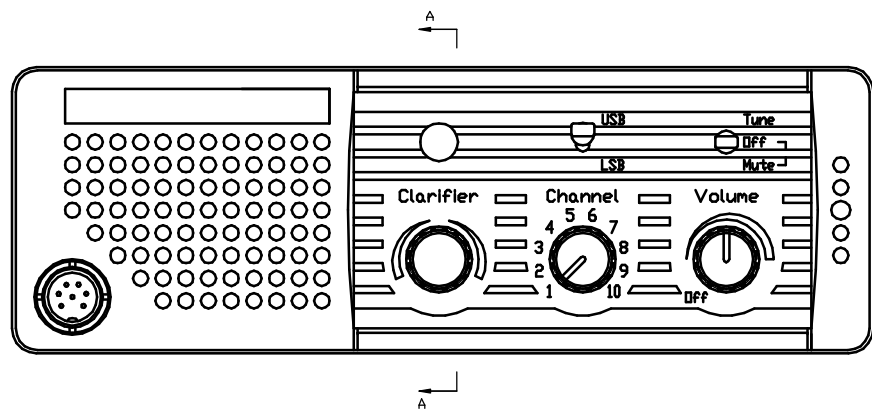

SECTION A - A

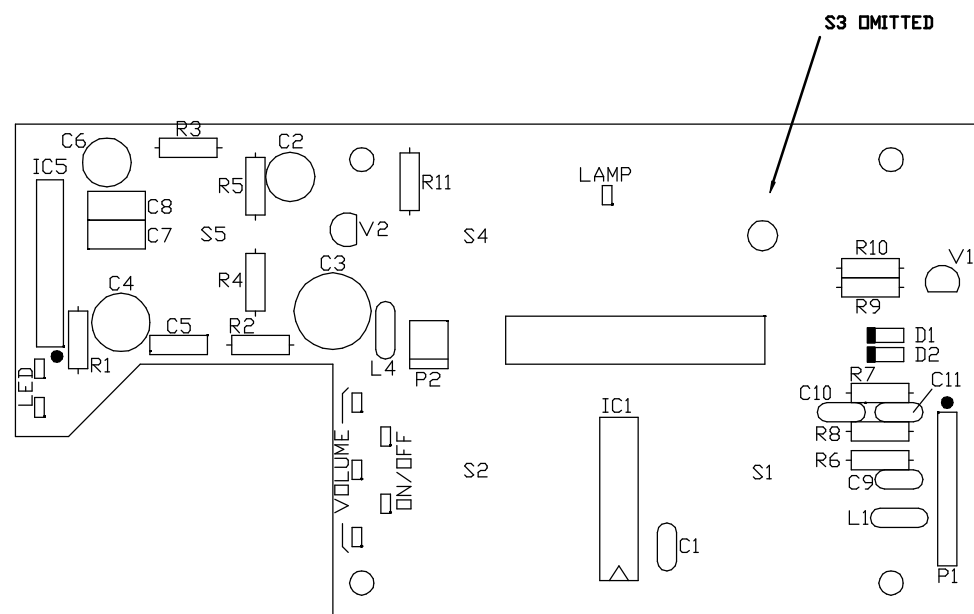
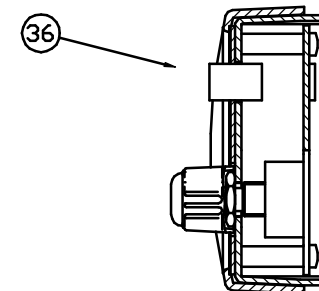

S3 OMITTED

PCB - 07-01647

ALL OTHER DETAIL - REF SHTS 2 & 3
(SCALE 2:1)

REMOVE BURRS & SHARP EDGES

	SCALE	1:1	© CODAN PTY LTD. A.C.N. 007 590 605: 1997 TITLE FRONT PANEL ASSY (X2) SMC
	DATE	27-02-97	
MATERIAL	DRN	AML	DRAWING/DOC NO. 08-04842
	CHKD		
FINISH	APPD	JFB 03-03-97	TOLERANCES UNLESS OTHERWISE STATED 2 PLACES DEC. ±0.25 1 PLACE DEC. ±0.5 0 PLACE DEC. ±1 ANGULAR ±2°
	ISS	8	
DIMENSIONS IN mm			SHT. 4 OF 5

DO NOT SCALE

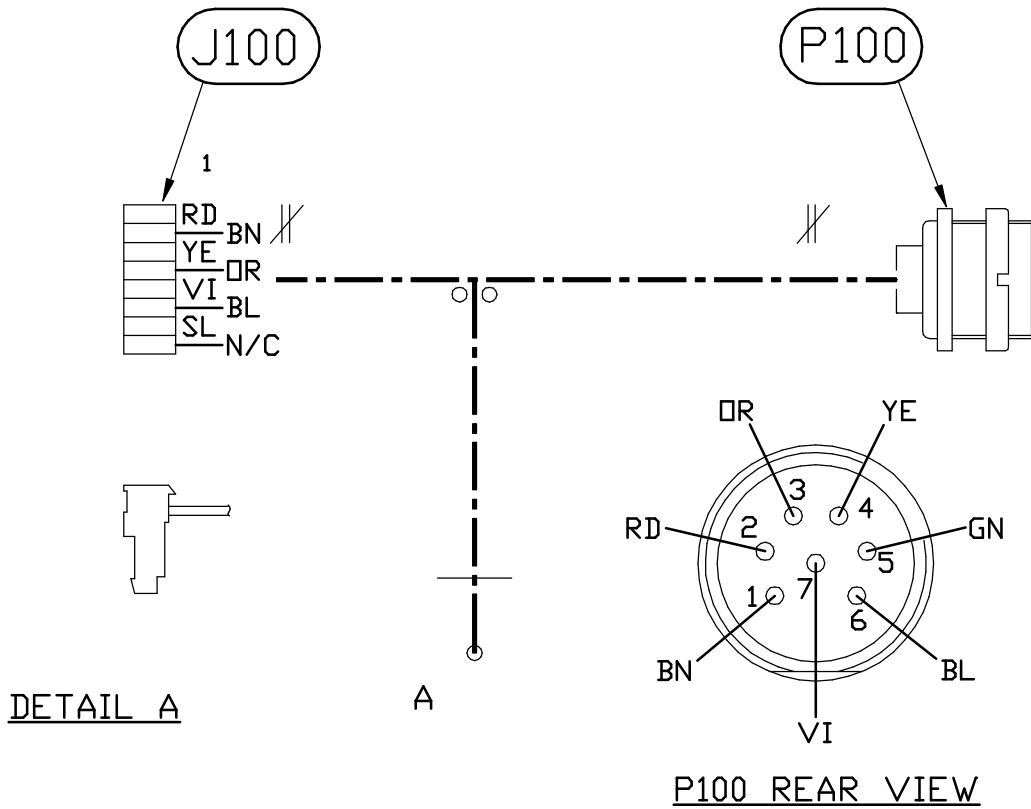

	WIRE	FROM	TO
RED	66-03072-002	J100/PIN 1	P100/PIN 2
BROWN	" -001	" 2	" 1
YELLOW	" -004	" 3	" 4
ORANGE	" -003	" 4	" 3
VIOLET	" -007	" 5	" 7
BLUE	" -006	" 6	" 6
SLATE	" -008	" 7	A
GREEN	" -005	A	P100/PIN 5

ISSUE 7
SHT 5 ADDED,
REF SHT 1.
C/R 25483
16-7-98 VS

ISSUE 8
REFER SHT 2

FILE No.
08\04842_8.DWG

REMOVE BURRS & SHARP EDGES

DIMENSIONS IN mm

			SCALE 1:1	© CODAN PTY LTD, A.C.N. 007 590 605: 1998					
	DRN	DB	DATE 04-02-92	TITLE LOOM, MIC					
MATERIAL	CHKD	RFW	25-05-92	DRAWING/DOC NO.					
FINISH	APPD	NJA	30-07-92	A 4	08-04842				
	TOLERANCES UNLESS OTHERWISE STATED				ISS 8	SHT. 5 OF 5			
	2 PLACES DEC.		±0.25						
1 PLACE DEC.		±0.5							
0 PLACE DEC.		±1							
ANGULAR		±2°							

DO NOT SCALE

CHANGE REQUEST

ISSUE B
V1 WAS BCX20
C/R 24530
NJA 22-05-96

ISSUE C
C3 POLARITY
ADDED.
C/R 24658
BCL 08-07-96

ISSUE 2
R9 WAS 270K
R1 WAS 4K7
R15, V3 ADDED.
C/R 24987
04-07-97 MJS

ISSUE 3
PCB SHORTENED,
COMPS RENUMB'RD
TABLE ADDED.
C/R 25721
09-11-98 RRU

ISSUE 4
NOTES 1-4 ADDED.
VIEW ADDED SHOWING V2
MOUNTED TO HEATSINK.
C/R 25886
13-198 PMK

ISSUE 5:
PCB WAS ISS -03
C/R 26392
GDD 21/12/99

FILE NAME
08\05235_5.DWG

NOTE:
E SHAPED BOARD (1B) IS BROKEN OFF
ALONG THIS EDGE, FITTED INTO
THE TWO SLOTS (1A) AND SOLDERED
WITH 0.5mm CLEARANCE

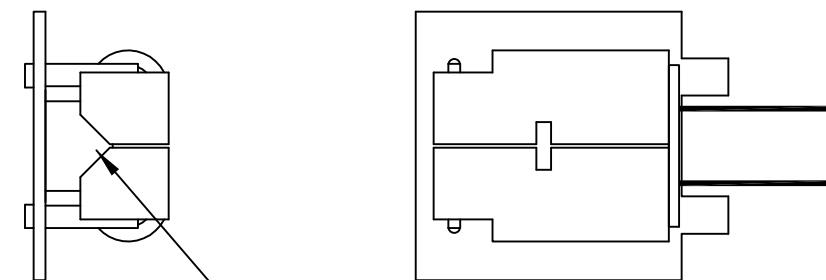
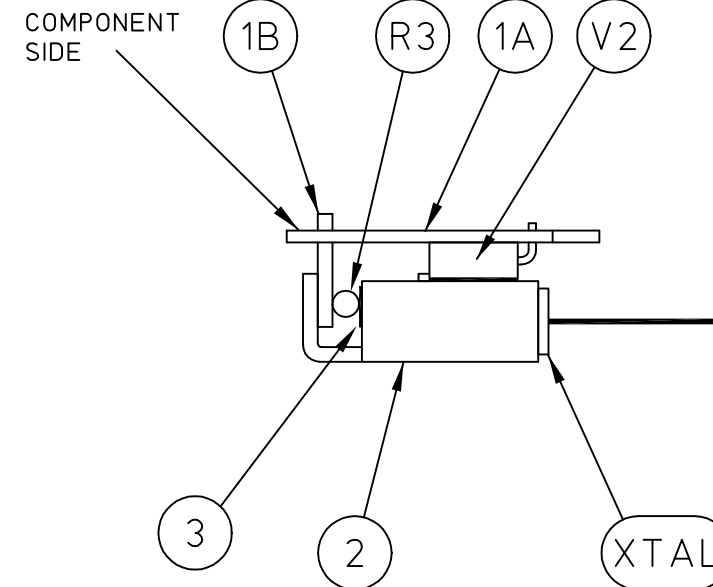
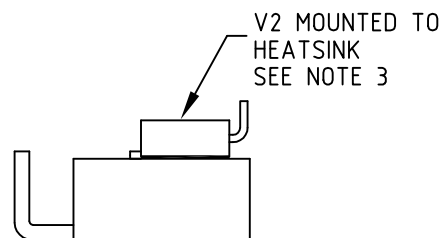
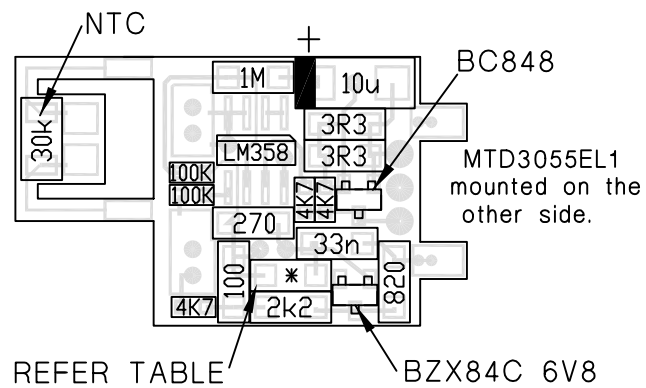
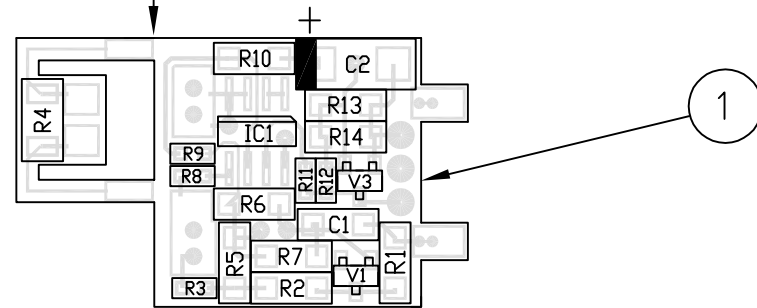

SOLDER HEATSINK TO PCB

NOTES:

1. E-SHAPED BOARD IS FITTED USING 75-80602.
2. V2 LEADS ARE PREFORMED USING 75-80601.
3. V2 IS MOUNTED TO HEATSINK USING 75-80600.
4. CARE MUST BE TAKEN TO AVOID EXCESS HEAT AS THIS CAN CAUSE HEATSINK TO COLLAPSE.

VERSION	R7
08-05235-001	220
08-05235-002	150

PCB 07-01732-04

		SCALE 2:1	© CODAN PTY LTD, A.C.N. 007 590 605: 1995									
	DRN	DB	DATE 09-01-96	TITLE CRYSTAL OVEN FINAL ASSEMBLY								
MATERIAL	CHKD	EF	26-02-96	DRAWING/DOC NO. 08-05235								
FINISH	APPD	JFB	30-09-96	A3	ISS							
	TOLERANCES UNLESS OTHERWISE STATED				B	C	1	2	3	4	5	SHT. 1
	2 PLACES DEC.	±0.25	1 PLACE DEC.		±0.5	0 PLACE DEC.	±1	ANGULAR	±2	DF	1	

Addendum



The following section is added to the HF SSB Transceiver X2 Technical Service Manual, Codan part number 15-02047 Issue 2, December 1993.

This addendum provides information on changes to the Crystal Oven.

The Crystal Oven information is provided in addition to that existing in Chapter 4, *Local Oscillators*. It describes how the oven maintains a constant temperature.

Drawings associated with the crystal oven information are:

- Crystal Oven Circuit Diagram 04-03095
- Crystal Oven Final Assembly 08-05235

The corresponding parts list is:

- Crystal Oven Parts List 08-05235-001

Local Oscillators

Introduction

Each synthesizer is locked to the reference oscillator. This consists of a 7.304 MHz crystal (Z3) held at a constant temperature by an oven, which is one of the following:

- a PTC thermistor (E1) at 60°C
- a high stability oven where the R3 NTC (Negative Temperature Coefficient) resistor measures the temperature of the crystal and causes the op-amp comparator IC1 to vary the current in the heating element V2 to maintain the temperature of 65°C to within $\pm 1^\circ\text{C}$

The temperature of the high stability oven is set by R4. V1, R12 and R13 limit the maximum current through V2 to approximately 400 mA.

DO NOT SCALE

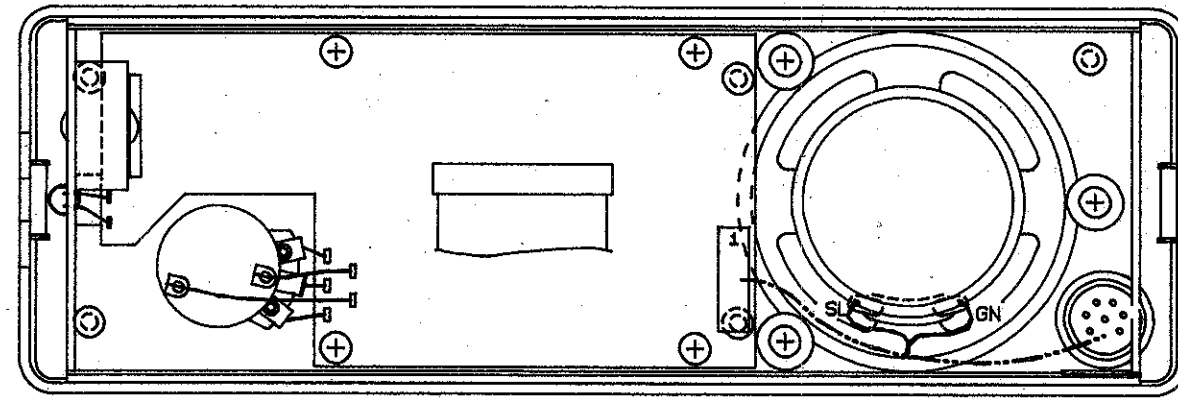

PA & CHASSIS ASSY
08-04841

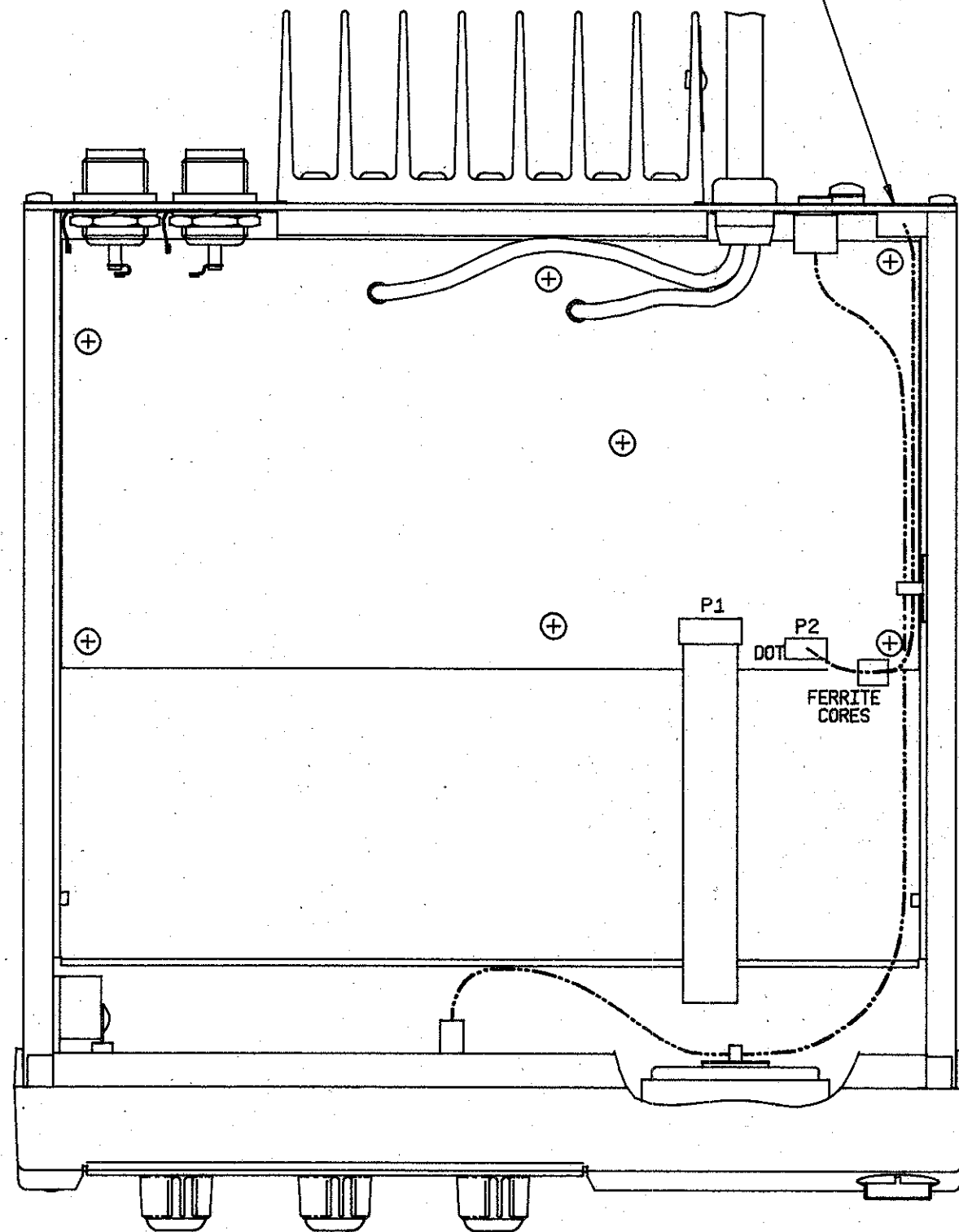

BOTTOM VIEW

Rx PCB ASSY
08-04840

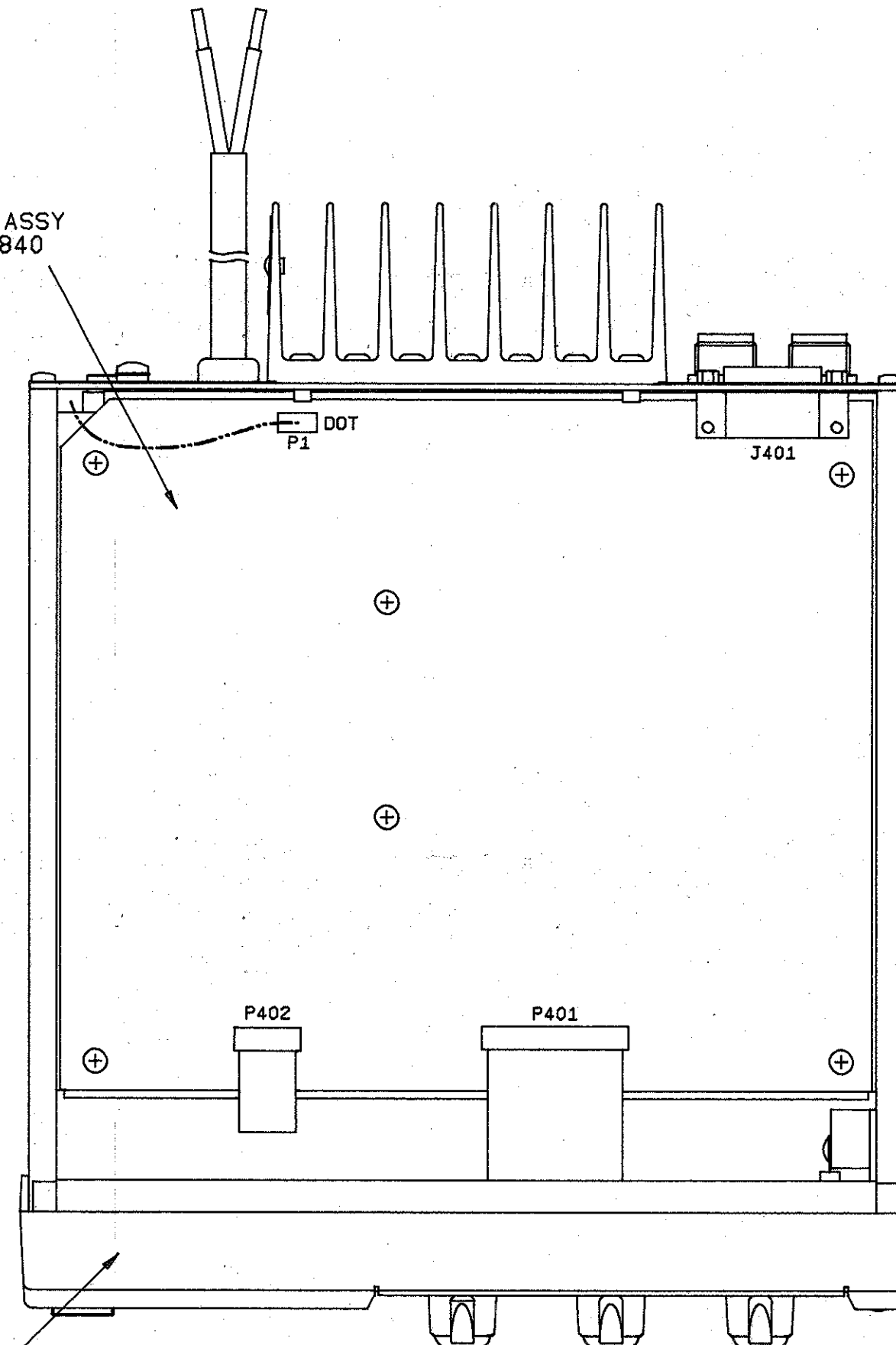

TOP VIEW

FRONT PANEL ASSY
08-04842

DISC FILE

	SCALE	1:1	COPYRIGHT © CODAN PTY.LTD. A.C.N. 007 590 605 TITLE TRANSCIEVER LAYOUT
	DRN	DB	
MATERIAL	CHKD	<i>PK</i>	21-7-92
	APPD	<i>PK</i>	22-7-92
FINISH	TOLERANCES		A2 16-00107
	UNLESS OTHERWISE STATED		
		2 PLACES DEC. ±	ISS 1
		1 PLACE DEC. ±	
		ANGULAR ±	SHT. 1 OF 1