

EMPOWR Knee System™

NATURAL MOTION TECHNOLOGY



SURGICAL TECHNIQUE



➤ Contents

System Features	3
Indications and Contraindications	4
Surgical Snap Shot	5
Preoperative Planning	7
Surgical Technique	8
<i>Femoral Preparation</i>	8
<i>Tibial Preparation</i>	12
<i>Recut Guides</i>	15
<i>Gap Assessment</i>	17
<i>Patella Preparation</i>	18
<i>Trial Reduction</i>	19
<i>Component Implantation</i>	21
Reference Guide	23
<i>Implant Dimensions</i>	23
<i>Sizing Chart</i>	25
<i>Instrument Guide</i>	27
<i>Implant Part Numbers</i>	37
Notes	40

DJO Surgical is a manufacturer of orthopedic implants and does not practice medicine. Only an orthopedic surgeon can determine what treatment is appropriate. Individual results of total joint replacement may vary. The life of any implant will depend on the patient's weight, age, activity level, and other factors.

System Features

FEMORAL AND TIBIAL COMPONENTS

The EMPOWR Knee System has 1-up, 1-down sizing interchangeability, allowing for intraoperative flexibility. In all sizing combinations, the Tibial Insert size always matches the Tibial Baseplate size.

The EMPOWR 3D Femoral Components may be matched with the same size Tibial Baseplate as the Femoral Component, the minus sized Tibial Baseplate, or one size up Tibial Baseplate. For example, a size 6 Femoral Component will match a size 6, size 6 minus, or size 7 Tibial Baseplate. Minus sized Tibial Baseplates are intended to be used when a larger Femoral Component will be matched with a smaller profile Tibial Baseplate. Minus sized tibial bases have the A/P and M/L profile of one size smaller tibial base.

The EMPOWR PS does not use the minus baseplate option. EMPOWR PS Femoral Components may be matched with the same size Tibial Baseplate as the Femoral Component, one size smaller Tibial Baseplate, or one size larger Tibial Baseplate.

TIBIAL INSERT

The Tibial Insert thicknesses are stated by the total tibial construct height (Baseplate + Insert), measured at the thinnest point.

EMPOWR 3D Knee Tibial Inserts are available in sizes 2 through 11, with five thicknesses (10, 12, 14, 16 and 19mm) available for each. The Tibial Insert size will always correspond with the Tibial Baseplate size. For example, a size 6 and a 6 minus Tibial Baseplate both accept a size 6 Tibial Insert.

The EMPOWR PS is available in sizes 2 through 11, with seven thicknesses (10, 11, 12, 13, 14, 16 and 19mm). The insert size will always match the baseplate size.

EMPOWR 3D KNEE SIZING CHART

		TIBIAL SIZE																				
		2 MINUS	2	3 MINUS	3	4 MINUS	4	5 MINUS	5	6 MINUS	6	7 MINUS	7	8 MINUS	8	9 MINUS	9	10 MINUS	10	11 MINUS	11	11 PLUS
FEMORAL SIZE	2	2	2																			
	3			3	3																	
	4					4	4															
	5							5	5													
	6									6	6											
	7											7	7									
	8													8	8							
	9															9	9					
	10																	10	10			
	11																			11	11	11

 This box denotes a size combination that is available, but not recommended as minus size tibial bases have the A/P and M/L profile of one size smaller tibial base.

EMPOWR PS KNEE SIZING CHART

		TIBIAL SIZE										
		2	3	4	5	6	7	8	9	10	11	
FEMORAL SIZE	18.5MM Box	2	2	3								
	3		2	3	4							
	4			3	4	5						
	5				4	5	6					
	6					5	6	7				
	7						6	7	8			
	8							7	8	9		
	9								8	9	10	
	10									9	10	11
	11										10	11

PATELLAR COMPONENT

A symmetrical, Domed Patella is used with the EMPOWR Knee System and is available in the following sizes and thicknesses:

SIZE/DIAMETER	THICKNESS
26	8MM
29	8MM
32	8MM
35	9MM
38	9MM

SAW BLADES

A 1.27mm sagittal saw blade is recommended for use with this system.

STERILE PINS

Sterile fluted 3.2mm pins are available for order from DJO for use with the EMPOWR Knee System.

➤ Indications and Contraindications

INDICATIONS

Joint replacement is indicated for patients suffering from disability due to:

- degenerative, post-traumatic or rheumatoid arthritis;
- avascular necrosis of the femoral condyle;
- post-traumatic loss of joint configuration, particularly when there is patellofemoral erosion, dysfunction or prior patellectomy;
- moderate valgus, varus or flexion deformities;
- treatment of fractures that are unmanageable using other techniques.

This device may also be indicated in the salvage of previously failed surgical attempts. This system is to be used for cemented applications only.

CONTRAINDICATIONS

Joint replacement is contraindicated where there is:

- infection (or a history of infection), acute or chronic, local or systemic;
- insufficient bone quality which may affect the stability of the implant;
- muscular, neurological or vascular deficiencies, which compromise the affected extremity;
- obesity;
- alcoholism or other addictions;
- materials sensitivity;
- loss of ligamentous structures;
- high levels of physical activity (e.g. competitive sports, heavy physical labor).
- The EMPOWR 3D Knee is also contraindicated for patients without sufficient soft tissue integrity to provide adequate stability.

The indications and contraindications for TKA vary among patients and are always the decision of the surgeon performing the procedure.

➤ Surgical Snap Shot



1 Drill IM canal.



2 Establish femoral alignment and determine distal cut depth.



3 Make distal cut.

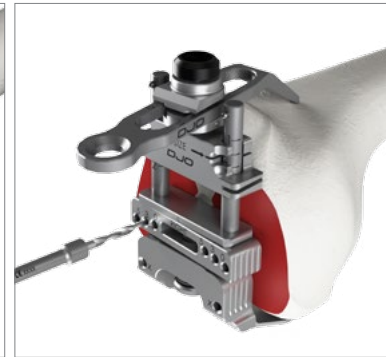

4 Size femur and set femoral rotation.



5 Make 4-in-1 femoral cuts.



6 Align PS Box Cut and make PS box resections (PS only).



7 Establish tibial alignment and determine resection depth.



8 Make tibial resection.



9 Assess resections and balance knee.



10 Select tibial size.

➤ Surgical Snap Shot



11 Ream for the tibial keel through the Tibial Punch Bushing.



12 Broach the tibial canal until the punch is fully seated.



13 Set the patella resection depth and resect the patella.



14 Drill holes for the patella pegs.



15 Insert trials.

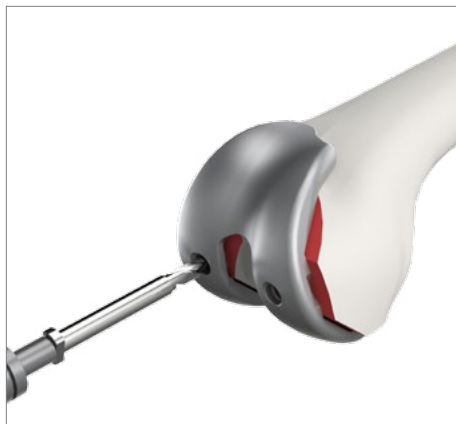

16 Drill holes for femoral pegs (3D only).



17 Implant final components.

➤ Preoperative Planning

Templates for the EMPOWR Knee System are available to aid in preoperative implant sizing.

With any bony deformity, use long standing radiographs to evaluate the angle between the mechanical axis of the leg and the anatomic axis of the femur. The normal mechanical axis is formed by a straight line which begins at the center of the femoral head, passes through the center of the knee joint and ends at the center of the ankle. The angle measured between the mechanical axis and the anatomic axis of the femur will determine which of the angle to set the Distal Femoral Alignment Guide to that will obtain a distal femoral cut which will be perpendicular to the mechanical axis of the joint. The goal of this preoperative planning exercise is to demonstrate the correct mechanical axis of the leg, promote minimal bone stock removal, and optimize collateral ligament balance in reconstruction.

djosurgical™

EMPOWR 3D Knee™ Femur X-ray Template

EMPOWR 3D Femur		
Size	M/L (mm)	Profile A/P (mm)
2	56.0	50.7
3	58.5	53.3
4	61.0	55.8
5	63.5	58.3
6	66.0	60.8
7	68.5	63.9
8	71.0	67.1
9	73.5	69.2
10	76.0	72.0
11	78.5	75.5

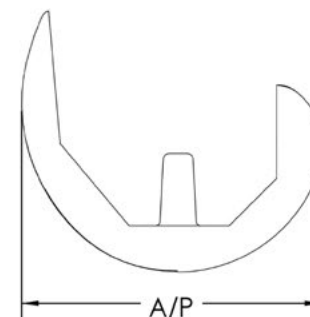
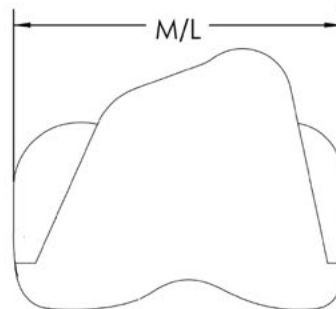

NOTE: This is intended to be used as a surgical planning aid and not as a measuring tool.

Cat. # 800-88-111 Rev B Artwork # 800-88-111-00
©2015 DJO, LLC



> Femoral Preparation



FIGURE 1

INTRAMEDULLARY EXPOSURE

Using the 8mm IM Drill, locate and drill a pilot hole into the intramedullary femoral canal. The inferior edge of this hole should be positioned approximately 1 to 2mm anterior to the intercondylar notch. Make the hole larger by toggling the bit inside the canal. This reduces the risk of fat emboli and allows the T-Handle IM Rod to seek the proper position in the canal. Irrigate and suction the canal to further decrease the risk of fat embolism. (FIGURE 1)

NOTE: Placement of the hole too superior will result in a femoral component position that is in relative extension with respect to the long axis of the femur. In contrast, placement of the hole too posterior or close to the apex of the intercondylar notch will result in a femoral component position which is in relative flexion compared to the long axis of the femur.

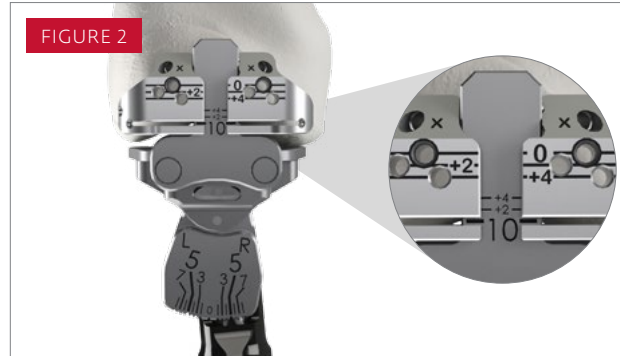

FIGURE 2

FEMORAL ALIGNMENT

Set the valgus angle on the Distal Femoral Alignment Guide by pulling back on the spring-loaded trigger and adjust to the appropriate left or right valgus angle from 2° to 8°. Typical valgus angles range from 4° to 6°.

Attach the Distal Femoral Cut Block to the Distal Femoral Alignment Guide and set the Distal Femoral Cut Block at the 10mm resection line on the indicator bar. The Distal Femoral Cut Block is set at 10mm when the 10mm line can be read through the cut slot of the Distal Femoral Cut Block. (FIGURE 2)

NOTE: Additional distal resection may be considered for knees with flexion contractures.



FIGURE 3

FEMORAL ALIGNMENT

Insert the T-Handle IM Rod through the Distal Femoral Alignment Guide then down the femoral IM canal until the distal resection paddles rest against the most prominent distal condyle. (FIGURE 3)

NOTE: The posterior condyles and epicondyles may be used as reference landmarks for rotation and to ensure a proper neutral placement of the Distal Femoral Resection Guide.

➤ Femoral Preparation



DISTAL RESECTION

Fix the position of the Distal Femoral Cut Block to the anterior cortex with two pins through the "0" holes.

Additional 2mm adjustments may be made by using the sets of holes marked +2 and +4. These sets of holes allow for re-adjustment of the Cut Block to remove more bone, in millimeters, as determined necessary.

Remove the assembled Distal Femoral Resection Guide and T-Handle IM Rod leaving only the Cut Block attached to the femur. Once the Cut Block depth is satisfactory, an additional fixation pin may be added through the divergent hole for increased fixation.

Using a saw blade, resect the distal femur. (FIGURE 4)
Remove all pins and Cut Block.

NOTE: A general guideline for the distal femoral resection is to remove an amount of bone that results in the saw blade passing near or at the depth of the intercondylar notch.



FEMORAL SIZING AND ROTATION

Mount the Femoral Sizer Stylus on the Femoral Sizer. Rotate the external rotation bar indicator on the Femoral Sizer so that the appropriate "Left" or "Right" orientation markings are visible when the Femoral Sizer is placed on the distal aspect of the bone. (FIGURE 5)

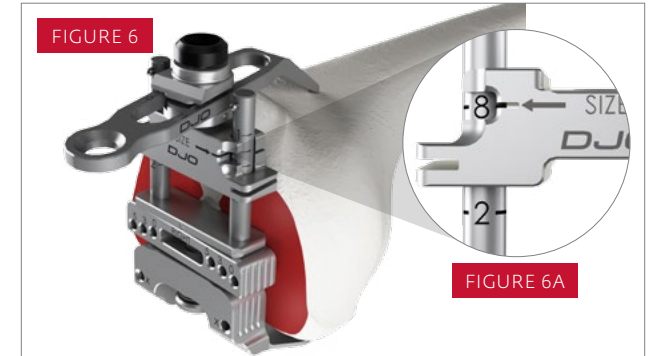

FEMORAL SIZING

Seat the Femoral Sizer flush against the distal femur using the Sizer feet to reference the posterior condyles. Place the Femoral Sizer Stylus tip on the lateral aspect of the anterior cortex. (FIGURE 6)

Femoral component size is read through the windows on the anterior face of the Femoral Sizer. (FIGURE 6A) Slide the Stylus anteriorly or posteriorly so the number matches what was read on the anterior face of the Femoral Sizer. This will determine the run out of the saw blade. The femoral component size is chosen when the size marked on the stylus and anterior face of the Femoral Sizer match.

Alternatively, the Angel Wing may be used in the slots of the Femoral Sizer to determine the exit point of the saw blade.

NOTE: If the knee is in between sizes, choose the larger size to avoid the potential for anterior femoral notching.

➤ Femoral Preparation



FEMORAL ROTATION

External rotation can be set at 0°, 3° or 5° from the posterior condylar axis using the 0°, 3° or 5° holes in the external rotation bar on the Femoral Sizer. Hold the Femoral Sizer in place and drill through the holes with the 3.2mm Femoral Drill to set the rotation for the 4-in-1 Cut Block. (FIGURE 7)

NOTE: In the instance that a hypoplastic condyle is present, place the middle of the zero degree holes along the midline of the distal femur and align the long axis of the holes to match the anatomy, such as perpendicular to the AP axis (i.e. Whiteside's line) or parallel to the rotational axis of the knee.



FEMORAL 4-IN-1 RESECTIONS

Insert the pegs of the appropriate size 4-in-1 Femoral Cut Block into the pre-drilled holes on the distal femur. Impact the face of the 4-in-1 Block using a mallet until the 4-in-1 Block is flush with the femur. The Angel Wing should be used to verify the anterior cut to avoid notching of the anterior cortex. (FIGURE 8)

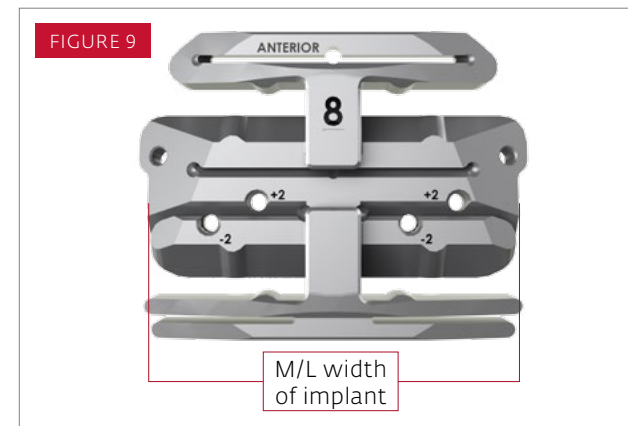

4-IN-1 CUT BLOCK

Additional 2mm adjustments may be made by using the sets of holes marked +2 and -2. These sets of holes allow for anterior or posterior re-adjustment of the cutting block to remove more or less bone, in millimeters, as necessary. To adjust the 4-in-1 Cut Block, drill through the appropriate holes in the 4-in-1 Cut Block, remove the 4-in-1 Cut Block from the femur, and re-insert the pegs of the 4-in-1 Cut Block in the new holes. (FIGURE 9)

NOTE: When using the 4-in-1 Cut Block for a size 2 or 3, the Femoral Shift Block is used to make the plus 2 or minus 2mm adjustments.

➤ Femoral Preparation



FIGURE 10

FEMORAL 4-IN-1 RESECTIONS

After final placement of the 4-in-1 Cut Block, pin the 4-in-1 Cut Block in place using 2" Headed Bone Pins. Make the anterior and posterior resections followed by the anterior and posterior chamfer resections using a saw blade.

After resections have been made, remove the pins and the 4-in-1 Cut Block with the Slap Hammer. (FIGURE 10)

NOTE: Posterior osteophytes should be removed to ensure full postoperative extension.



FIGURE 11

POSTERIOR STABILIZED BOX CUT

PS Box Cut Guides are used to prepare for a PS femoral component. Box Cut Guides are designed to replicate the anterior profile of the femoral component and are labeled "RL" for the Right Lateral flange and "LL" for the Left Lateral flange. (FIGURE 11)

Two types of PS Box Cut Guides are available: Standard and Captured. The selection of the guide will depend on surgeon preference. Different types of box guides accomplish the same goal.



FIGURE 12

STANDARD PS BOX CUT (SAW)

Select the Standard PS Box Cut Guide that corresponds to the selected size femoral component. Place the Box Cut Guide in the desired ML position, resting against the anterior and distal surfaces of the bone.

Pin the selected PS Box Cut Guide in place with Tibial Bone Pins. (FIGURE 12) Using a reciprocating saw with a saber blade, resect the sides and back of the box.

➤ Femoral Preparation



STANDARD PS BOX CUT (SAW AND CHISEL)

The Modular Capture may be used in conjunction with the Standard PS Box Cut Guides and is intended to allow the user to prepare the back of the box with a Chisel.

To use, place the Modular Capture over the anterior portion of the Standard PS Box Cut Guide and seat it until fully engaged. Pin the selected PS Box Cut Guide in place with Tibial Bone Pins.

Insert the corresponding size Chisel in the Modular Capture and resect the back of the PS box half way, leaving the Chisel as a back stop for the oscillating saw. **(FIGURE 13)** Use the oscillating saw to cut the sides of the PS box.

Ensure the cuts for the sides are completed by aligning the saw blade perpendicular to the chisel. Slowly impact the Chisel until it is fully seated. The Chisel will stop at the appropriate depth for the indicated size.

NOTE: Failure to complete the entire side wall cuts of the PS box prior to final Chisel impaction may increase the risk of condylar fracture.



CAPTURED PS BOX CUT (SAW AND CHISEL)

Select the Captured PS Box Cut Guide that corresponds to the selected size femoral component. Place the Box Cut Guide in the desired ML position, resting against the anterior and distal surfaces of the bone.

Pin the selected PS Box Cut Guide in place with the Tibial Bone Pins. Insert the corresponding size Chisel into the Captured PS Box Cut Guide and resect the back of the PS box half way, leaving the Chisel as a back stop for the oscillating saw. **(FIGURE 14)** Use the oscillating saw to cut the sides of the PS box.

Ensure the cuts for the sides are completed by aligning the saw blade perpendicular to the chisel. Slowly impact the Chisel until it is fully seated. The Chisel will stop at the appropriate depth for the indicated size.

NOTE: Failure to complete the entire side wall cuts of the PS box prior to final Chisel impaction may increase the risk of condylar fracture.

➤ Tibial Preparation



EXTRAMEDULLARY ALIGNMENT

Assemble the EM Ankle Clamp, EM Proximal Body, EM Distal Body, and selected Tibial Cut Block (left or right in neutral or 3°).

Position the Ankle Clamp around the patient's ankle. Adjust the overall length of the EM Tibial Resection Guide to the appropriate tibial length using the lever on the EM Proximal Body. **(FIGURE 15)**

Place the Tibial Stylus into the medial hole of the resection guide. Generally the Stylus is set to resect 10mm from the less affected compartment, or 2mm from the most affected compartment. The Angel Wing should be used to check the amount of bone to be resected and visualize planned tibial slope.

Adjust the resection by adjusting the height of the Proximal Body until the desired resection depth is found. The height of the Proximal Body is locked when the lever is in the middle position. **(FIGURE 15A)**

➤ Tibial Preparation



EXTRAMEDULLARY ALIGNMENT

If a shorter extramedullary guide is needed, the Transition Module may be used in conjunction with the Extramedullary Guide. Clip the Transition Module around the EM Proximal Body and attach the selected Tibial Cut Block to the Transitional Module. (FIGURE 16) Lock the Tibial Cut Block to the EM Proximal Body by turning the knob on the Transition Module until it is tight.



EXTRAMEDULLARY ALIGNMENT

Position the center of the Tibial Cut Block just medial to the tibial tubercle. With the foot in the neutral position, align the Proximal Body with the second metatarsal. This is accomplished by the M/L EM Ankle Adjustment Body at the ankle. Additionally, the Tibial Cut Block may be pinned through the center slot to provide stability while the M/L position and slope of the EM Ankle Adjustment Body is adjusted.

When the proper resection depth is achieved, secure the Tibial Cut Block onto the tibia using self-drilling smooth pins through the holes marked "0". These are highlighted with a laser mark. (FIGURE 17)

Remove the remainder of the Tibial EM Assembly by depressing the black button to disengage the Proximal Rod Body and Ankle Clamp from the Cut Block.

NOTE: For an anatomically sloped resection, place the Angel Wing in the cutting slot of the Tibial Cut Block and adjust the long axis of the EM Ankle Clamp by engaging the lever and pulling away from the ankle.



INTRAMEDULLARY ALIGNMENT

Using the 8mm IM Drill, locate and drill a pilot hole into the intramedullary tibial canal. The posterior edge of this hole should be positioned 3 to 5 mm anterior to the pinnacle of the proximal tibial spine and in line with the tibial tubercle. Insert the T-Handle IM Rod into the pilot hole created by the IM drill and introduce the IM Rod beyond the depth of the pilot hole to open the intramedullary canal. Remove the T-Handle IM Rod. Slide the IM Guide Base over the T-Handle IM Rod and insert the T-Handle IM Rod into the intramedullary canal. (FIGURE 18)

➤ Tibial Preparation

FIGURE 19



INTRAMEDULLARY ALIGNMENT

Assemble the Transition Module and Tibial Stylus to the selected 0° Tibial Cut Block. Insert the 0°/3°/6° IM Guide through the Transition Module from the bottom. (FIGURE 19)

FIGURE 20



INTRAMEDULLARY ALIGNMENT

Select the desired amount of tibial slope (0°, 3°, or 6°) and slide the 0°/3°/6° IM Guide over the corresponding prongs of the IM Guide Base.

Position the center of the Tibial Cut Block just medial to the tibial tubercle. When the desired resection is found, lock the Tibial Cut Block in place by turning the knob on the Transition Module until it is tight. (FIGURE 20)

FIGURE 21



INTRAMEDULLARY ALIGNMENT

Pin the Tibial Cut Block onto the tibia using self-drilling smooth pins through the holes marked "0" which are highlighted with a laser mark.

Unlock the Transition Module and disengage it from the Tibial Cut Block by squeezing the levers on the anterior side and pulling it straight towards the user. Remove the Stylus, 0°/3°/6° IM Guide, IM Guide Base and T-Handle IM Rod. (FIGURE 21)

➤ Tibial Preparation



FIGURE 22

TIBIAL ALIGNMENT

To assess proper alignment of the Tibial Cut Block, insert the Alignment Rod Guide in the resection slot of the Tibial Cut Block and insert the Alignment Rod through the Alignment Rod Guide.

If the Alignment Rod is too long to accurately assess alignment, slide the Modular Stop on the Alignment Rod before inserting it into the Alignment Rod Guide. (FIGURE 22) After pinning, the Tibial Cut Block may be adjusted distally using the holes marked +2 and +4 to add an additional 2mm or 4mm to the resection depth. The cross pin hole may be used for additional fixation.



FIGURE 23

TIBIAL RESECTION

Resect the proximal tibia using a saw blade. (FIGURE 23)

➤ Recut Guides



FIGURE 24

+2mm, 2° RECUT GUIDES

Recut guides are available in three configurations and may be used after the proximal tibial resection. The holes on the guides are convergent and do not correlate to the holes on the Tibial Cut Block.

The 2mm Recut Guide and 2° Slope Recut Guide are used by placing the feet on the proximal tibial resection and pinning the guide to the tibia. (FIGURE 24)

➤ Recut Guides



VARUS/ VALGUS RECUT GUIDE

The 2° Varus/ Valgus Recut Guide will change the varus/ valgus orientation of the proximal tibial resection depending on which way the guide is oriented.

(FIGURE 25)



DISTAL FEMORAL RECUT GUIDE

If a distal femoral recut is deemed necessary after the 4-in-1 resections have been made, the 2mm Distal Recut Spacer may be used. The 2mm Distal Recut Spacer is attached to the internal face of the Distal Femoral Alignment Guide and allows the user to make a 2mm distal femoral resection. (FIGURE 26)

Attach the 2mm Distal Recut Spacer and the Distal Femoral Cut Block to the Distal Femoral Alignment Guide. Insert the T-Handle IM Rod through the Distal Femoral Alignment Guide then down the femoral IM canal until the distal resection paddles rest against the most prominent distal condyle. Pin the Distal Femoral Cut Block and recut the distal femur. Chamfer resections will need to be recut in order to achieve proper femoral component fit.

➤ Gap Assessment

Spacer Blocks are available to evaluate proper bone removal and balancing of the joint space. Spacer Blocks are used with no trials in place, with the Spacer Block representing the total combined thickness of the baseplate, insert, and femoral component. For example, using the “10mm” Block will represent the overall implant thickness when using a 10mm insert in both extension and flexion. (FIGURE 27)

NOTE: If gaps are not adequate, soft tissue releases or bone cuts can balance the gaps. Refer to the chart below.



FIGURE 27

➤ Tibial Preparation



FIGURE 28

TIBIAL BASEPLATE PREPARATION

Select the appropriate size Tibial Baseplate Trial. Minus size tibial bases have the A/P and M/L profile of one size smaller tibial base and are only used in conjunction with the 3D femoral component. Connect the Baseplate Trial that most accurately matches the periphery of the tibial plateau to the Baseplate Trial Handle. The Alignment Rod may be inserted through the Baseplate Trial Handle to assess Baseplate Trial alignment. Once appropriately aligned, secure the trial in place with two short Tibial Bone Pins. Using the Multi-Pin Tool, grasp the Tibial Bone Pins and insert them into the most posterior holes in the Baseplate Trial. (FIGURE 28)

WARNING: Only the short Fixation Pin may be used in the anterior hole of the Baseplate Trial.

NOTE: Care should be taken to avoid excessive amounts of tibial external rotation. Floating the Baseplate Trial and Insert Trial may help facilitate proper tibial rotation.

EXTENSION

		TIGHT	BALANCED	LOOSE
FLEXION	TIGHT	downsize insert thickness, cut more proximal tibia	select smaller size 4-in-1 guide (to downsize femoral component) and shift anteriorly to cut more posterior condyle	select smaller size 4-in-1 guide (to downsize femoral component) and shift anteriorly to cut more posterior condyle and use a thicker insert as necessary
	BALANCED	recut distal femur	no adjustment necessary	cut more posterior slope and use thicker insert
	LOOSE	recut distal femur and use thicker insert if necessary	change may not be necessary. If desired, recut distal femur and use thicker poly	use thicker insert

➤ Tibial Preparation



TIBIAL BASEPLATE PREPARATION

Place the Tibial Punch Bushing in the center recess of the Baseplate Trial and use the Tibial Reamer to ream the area for the tibial keel. (FIGURE 29)

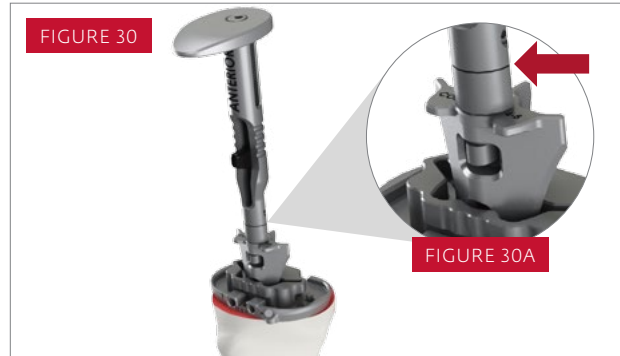

TIBIAL KEEL PREPARATION

Select the appropriate size Tibial Punch: Small (2-3), Medium (4-8) or Large (9-11) and connect it to Tibial Punch Handle. For minus bases, use the same size Tibial Punch as non-minus bases. For example, use a size 5 Punch for a size 5 minus base. Center the appropriate size Tibial Punch in the Tibial Punch Bushing and broach the tibial canal until the punch is fully seated. (FIGURE 30) The punch is fully seated when the engraved line on the Tibial Punch Handle is flush with the top of the Tibial Punch Bushing. (FIGURE 30A) If desired, the Tibial Punch may be disengaged from the Tibial Punch Handle and left in place during trialing. To remove the Tibial Punch, pull back on the handle and insert the Tibial Punch Handle into the Modular Punch.

➤ Patella Preparation



PATELLA RESECTION DEPTH

Measure the overall patellar thickness using the Caliper. Select the Patella Osteotomy Guide and set the stylus to indicate an amount of bone equal to the thickness of the patellar component to be used. (FIGURE 31) To set the stylus depth, turn the dial clockwise to increase the depth of the resection. Each half turn represents 1mm thickness. The resection depth can be read off the top of the stylus. (FIGURE 31A)

NOTE: Use care not to overresect the patella.



PATELLA RESECTION

Using a saw blade, resect the patella (FIGURE 32).

➤ Patella Preparation



PATELLA PEG PREPARATION

Use the Patella Drill Guides to size the resected patella. Five diameter sizes of patellas are available: 26, 29, 32, 35 and 38mm. Insert the selected Patella Drill Guide into the Patella Clamp. Clamp the spikes on the Patella Drill Guide to the resected patella and secure the Patella Clamp using the locking hook. **(FIGURE 33A)** Drill for the patella pegs using the Patella Drill. **(FIGURE 33)** Do not drill through the center hole in the Patella Drill Guide. Remove the Patella Clamp and insert the selected Patella Trial.

➤ Trial Reduction



FEMORAL TRIAL IMPACTION

Leave the Baseplate Trial pinned in place. Connect the Femoral Impactor Head to the Impactor Handle and impact the Femoral Trial onto the prepared femur. **(FIGURE 34)**

NOTE: *The protrusion of the femoral impactor can be used to adjust flexion of the femoral implant.*



FEMORAL TRIAL IMPACTION

Alternatively, the Locking Femoral Impactor may be used to position and impact the Femoral Trial. Connect the Locking Femoral Impactor to the Impactor Handle. Depress the finger holds and clip the Locking Femoral Impactor to the Femoral Trial. Turn the Impactor Handle clockwise to secure the Femoral Trial to the Locking Femoral Impactor. **(FIGURE 35)** Impact the Femoral Trial onto the prepared bone.

➤ Trial Reduction



INSERT TRIAL SELECTION

In all configurations, the insert size will always match the tibial baseplate size.

3D inserts are side specific and come in left and right configurations. 3D inserts are available in five thicknesses: 10, 12, 14, 16, and 19mm.

PS inserts are symmetric and available in seven thicknesses: 10, 11, 12, 13, 14, 16, and 19mm. The EMPOWR PS has two additional insert configurations: 5 Bridge Up and 6 Bridge Down. These inserts are used to bridge the gap between the large and small PS Box width. The 5 Bridge Up is used to bridge a size 5 tibial baseplate up to a size 6 PS femur. The 6 Bridge Down is used to bridge a size 6 tibial baseplate down to a size 5 PS femur. These inserts are designated with a color dot on the post of the insert that corresponds to the dot on the appropriately sized femoral trial. (FIGURE 36)



ARTICULATING SPACER TRIALS

For Insert Trials with thicknesses of 16 or 19mm, use the appropriate size Articulating Spacer Trial in conjunction with the proper thickness Insert Spacer Trial. (FIGURE 37) The Insert Trial Handle is used to hold the Articulating Spacer Trial and the Insert Spacer Trial together.



TRIAL INSERTION

Using the Insert Trial Handle, grasp the preferred thickness Trial Insert and insert it into the Baseplate Trial. (FIGURE 38)

➤ Trial Reduction



FEMORAL PEG PREPARATION

If the 3D femur will be implanted, the Femoral Peg Drill is used to prepare for the pegs on the back of the femoral implant. (FIGURE 39)



TRIAL IMPLANT REMOVAL

After the trial reduction is complete, remove the Femoral Trial. The 3D Femoral Trial is removed by inserting the Slap Hammer into the intercondylar notch vertically, then turning it horizontally to engage the 3D Femoral Trial. The PS Femoral Trial is removed by inserting the Slap Hammer vertically in the intercondylar notch. During removal, keep one hand on the Femoral Trial to control its extraction. (FIGURE 40)

Remove the Trial Insert using the Insert Trial Handle. Remove the Tibial Bone Pins with the Multi Pin Tool. Remove the Baseplate Trial and Tibial Punch if it was left in during trialing.

➤ Component Implantation



FEMORAL COMPONENT IMPLANTATION

The order for implantation is left up to the discretion of the surgeon.

Select the appropriate femoral component. Place cement on the underside of the femoral component and impact the femoral component on the bone using the Femoral Impactor Head or Locking Femoral Impactor and Impactor Handle. Remove excess cement. (FIGURE 41 and 41A)

NOTE: The protrusion of the femoral impactor can be used to adjust flexion of the femoral implant.

➤ Component Implantation



FIGURE 42

BASEPLATE IMPLANTATION

Select the appropriately sized tibial baseplate. Place cement on the underside of the baseplate and impact it into place using the Baseplate Impactor Head and Impactor Handle. Remove excess cement. **(FIGURE 42)**

NOTE: Keeping the knee in full extension may facilitate cementing.



FIGURE 43

INSERT IMPACTION

After ensuring that the tray is completely free of debris, place the appropriate insert into the baseplate. Engage the insert into the posterior captures of the baseplate and impact it with the Insert Impactor Head and Impactor Handle. When correctly impacted the anterior insert tabs will engage behind the anterior lip of the baseplate. **(FIGURE 43)**



FIGURE 44

PATELLA IMPLANTATION

Select the appropriate patella component. Place cement on the underside of the patella component. Insert the patella component and use the Patella Clamp with attached Patella Seater to seat the patella. Secure the Patella Clamp using the locking hook. Remove excess cement. The Patella Clamp and Patella Seater may be left in place while the cement cures. **(FIGURE 44)**

➤ Reference Guide

IMPLANT DIMENSIONS

EMPOWR 3D Knee System Femur

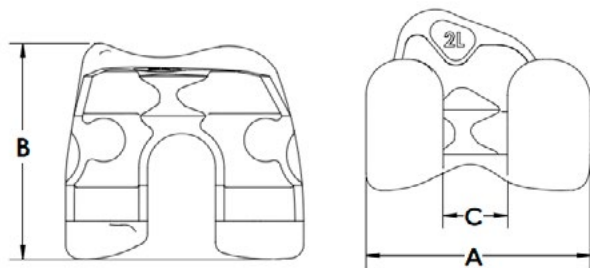

Size	M/L(mm) Dim 'A'	A/P(mm) Dim 'B'	Dim 'C' (mm)
2	56.0	50.8	16
3	58.5	53.3	16
4	61.0	55.8	16
5	63.5	58.3	16
6	66.0	60.8	16
7	68.5	63.9	16.3
8	71.0	67.1	18.1
9	73.5	69.3	18.1
10	76.0	72.1	18.1
11	78.5	75.1	19.1

EMPOWR Knee System Baseplate

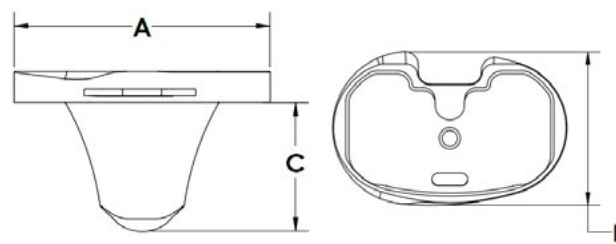

Size	M/L(mm) Dim 'A'	A/P(mm) Dim 'B'	Dim 'C' (mm)
2-	58.9	38.5	31.0
2	61.4	40.0	31.0
3	63.9	41.5	31.0
4	66.4	43.4	35.1
5	69.0	45.1	35.1
6	71.5	46.8	35.1
7	73.9	48.4	35.1
8	76.4	49.9	35.1
9	79.1	51.7	43.0
10	81.7	53.4	43.0
11	84.2	55.0	43.0
11+	86.9	56.8	43.0

All-Poly Domed Tri-Peg Patella

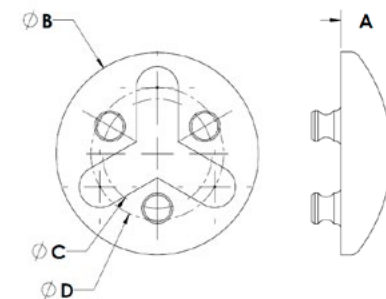

Size	M/L(mm) Dim 'A'	A/P(mm) Dim 'B'	Dim 'C' (mm)	Dim 'D' (mm)
26	8	26	17.3	17.7
29	8	29	17.3	20.7
32	8	32	17.3	20.9
35	9	35	20.9	20.9
38	9	38	20.9	20.9

➤ Reference Guide

IMPLANT DIMENSIONS

EMPOWR PS Knee System Femur

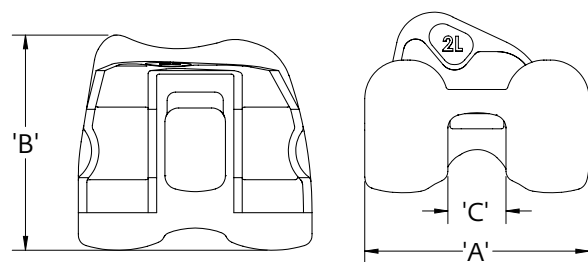

Size	M/L(mm) Dim 'A'	A/P(mm) Dim 'B'	Dim 'C' (mm)
2	56.0	51.6	14.4
3	58.5	54.3	14.4
4	61.0	56.2	14.4
5	63.5	58.8	14.4
6	66.0	60.9	18.4
7	68.5	64.1	18.4
8	71.0	67.8	18.4
9	73.5	69.5	18.4
10	76.0	71.5	18.4
11	78.5	75.2	18.4

EMPOWR Knee System Baseplate

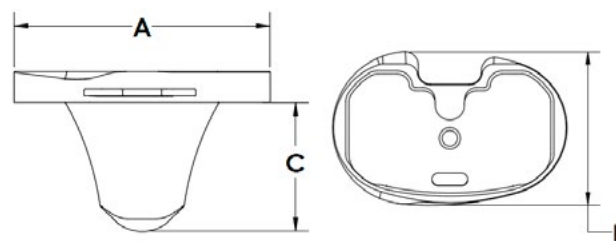

Size	M/L(mm) Dim 'A'	A/P(mm) Dim 'B'	Dim 'C' (mm)
2	61.4	40.0	31.0
3	63.9	41.5	31.0
4	66.4	43.4	35.1
5	69.0	45.1	35.1
6	71.5	46.8	35.1
7	73.9	48.4	35.1
8	76.4	49.9	35.1
9	79.1	51.7	43.0
10	81.7	53.4	43.0
11	84.2	55.0	43.0

All-Poly Domed Tri-Peg Patella

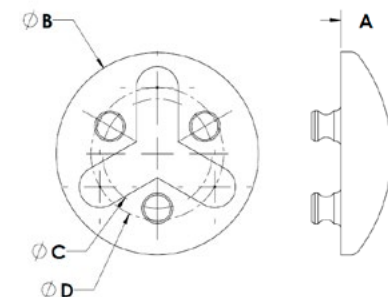

Size	M/L(mm) Dim 'A'	A/P(mm) Dim 'B'	Dim 'C' (mm)	Dim 'D' (mm)
26	8	26	17.3	17.7
29	8	29	17.3	20.7
32	8	32	17.3	20.9
35	9	35	20.9	20.9
38	9	38	20.9	20.9

➤ Reference Guide

EMPOWR 3D SIZING CHART

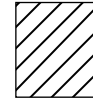

This box denotes a size combination that is available, but not recommended as minus size tibial bases have the A/P and M/L profile of one size smaller tibial base.

		TIBIAL SIZE																						
		2 MINUS	2	3 MINUS	3	4 MINUS	4	5 MINUS	5	6 MINUS	6	7 MINUS	7	8 MINUS	8	9 MINUS	9	10 MINUS	10	11 MINUS	11	11 PLUS		
FEMORAL SIZE	2	2	2	2	Hatched	3																		
	3				3	3	Hatched	4																
	4							4	4	Hatched	5													
	5										5	5	Hatched	6										
	6												6	6	Hatched	7								
	7														7	7	Hatched	8						
	8																8	8	Hatched	9				
	9																		9	9	Hatched	10		
	10																				10	10	Hatched	
	11																						11	11

➤ Reference Guide

EMPOWR PS SIZING CHART

		TIBIAL SIZE										
		2	3	4	5	6	7	8	9	10	11	
FEMORAL SIZE	18.5MM Box	2	2	3								
		3	2	3	4							
		4		3	4	5						
		5			4	5	6 BRIDGE DOWN					
	22.5MM Box	6				5 BRIDGE UP	6	7				
		7					6	7	8			
		8						7	8	9		
		9							8	9	10	
		10								9	10	11
		11									10	11

➤ Reference Guide

INSTRUMENT GUIDE

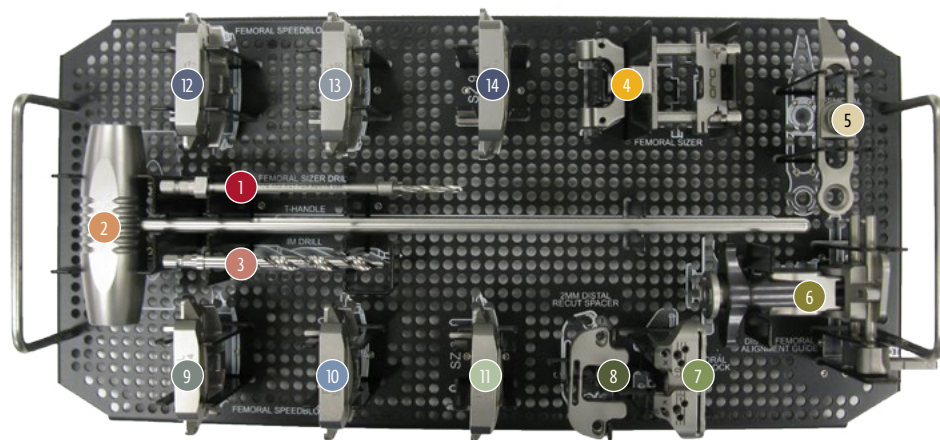

EMPOWR Knee Femoral Prep

Part Number	Description
800-99-094	Case, EMPOWR DRF Femoral Prep
1 800-05-007	3.2mm Femoral Sizer Drill
2 800-05-023	T-Handle IM Rod
3 800-01-299	IM Drill
4 800-05-034	Femoral Sizer 2
5 800-05-028	Femoral Sizer Stylus 2
6 800-05-001	Distal Femoral Alignment Guide
7 800-05-003	Distal Femoral Cut Block
8 800-05-004	2mm Distal Recut Spacer
9 800-05-014	4-in-1 Cut Block, SZ 4
10 800-05-015	4-in-1 Cut Block, SZ 5
11 800-05-016	4-in-1 Cut Block, SZ 6
12 800-05-017	4-in-1 Cut Block, SZ 7
13 800-05-018	4-in-1 Cut Block, SZ 8
14 800-05-019	4-in-1 Cut Block, SZ 9

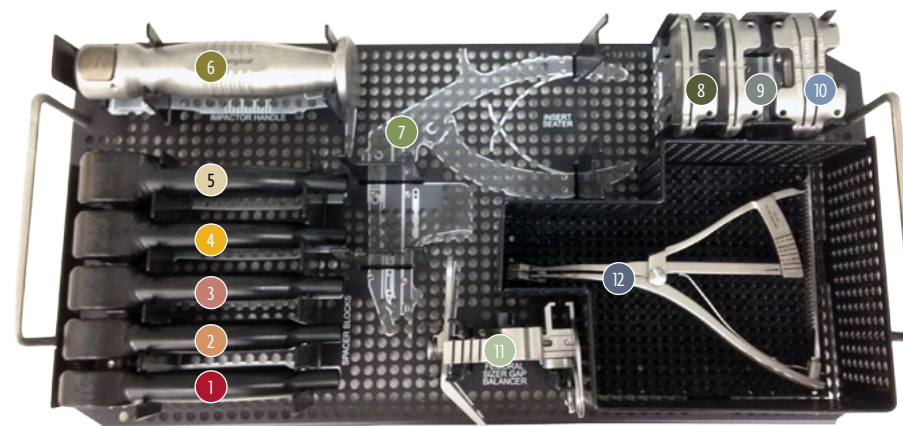

EMPOWR Knee Bonus Tray

Part Number	Description
800-99-097	Case, EMPOWR Bonus Tray
1 801-05-101	10 mm Insert Spacer Block
2 801-05-102	12 mm Insert Spacer Block
3 801-05-103	14 mm Insert Spacer Block
4 801-05-104	16 mm Insert Spacer Block
5 801-05-105	19 mm Insert Spacer Block
6 800-05-024	Impactor Handle
7 801-05-024	EMPTY (Insert Seater)
8 801-05-021	2° Slope Recut Guide
9 801-05-023	2 mm Recut Guide
10 801-05-022	2° Varus/Valgus Recut Guide
11 800-05-101	EMPTY (Gap Balancer)
12 800-05-102	EMPTY (Gap Balancer Lamina Spreader)

➤ Reference Guide

INSTRUMENT GUIDE

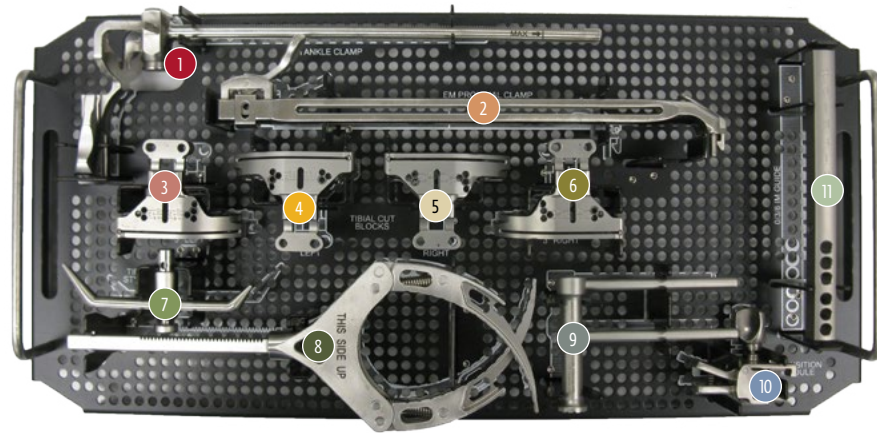

EMPOWR Knee Tibial Prep: Upper Tray

Part Number	Description
800-99-095	Case, EMPOWR Tibial Prep
1 801-05-002	EM Distal Body
2 801-05-113	EM Proximal Body 2
3 801-05-009	Tibial Cut Block, 3°, Left
4 801-05-007	Tibial Cut Block, 0°, Left
5 801-05-008	Tibial Cut Block, 0°, Right
6 801-05-010	Tibial Cut Block, 3°, Right
7 801-05-006	Tibial Stylus
8 801-05-001	EM Ankle Clamp
9 801-05-011	IM Guide Base
10 801-05-004	Transition Module
11 801-05-012	0°/3°/6° IM Guide



EMPOWR Knee Tibial Prep: Lower Tray

Part Number	Description
1 801-05-326	Baseplate Trial, 4R
801-05-325	Baseplate Trial, 4R Minus
2 801-05-306	Baseplate Trial, 4L
801-05-305	Baseplate Trial, 4L Minus
3 801-05-328	Baseplate Trial, 5R
801-05-327	Baseplate Trial, 5R Minus
4 801-05-308	Baseplate Trial, 5L
801-05-307	Baseplate Trial, 5L Minus
5 801-05-330	Baseplate Trial, 6R
801-05-329	Baseplate Trial, 6R Minus
6 801-05-310	Baseplate Trial, 6L
801-05-309	Baseplate Trial, 6L Minus
7 801-05-332	Baseplate Trial, 7R
801-05-331	Baseplate Trial, 7R Minus
8 801-05-312	Baseplate Trial, 7L
801-05-311	Baseplate Trial, 7L Minus

Part Number	Description
9 801-05-334	Baseplate Trial, 8R
801-05-333	Baseplate Trial, 8R Minus
10 801-05-314	Baseplate Trial, 8L
801-05-313	Baseplate Trial, 8L Minus
11 801-05-336	Baseplate Trial, 9R
801-05-335	Baseplate Trial, 9R Minus
12 801-05-316	Baseplate Trial, 9L
801-05-315	Baseplate Trial, 9L Minus
13 801-05-017	Baseplate Trial Handle
14 801-05-020	Tibial Punch Bushing
15 801-05-013	Tibial Reamer
16 801-05-018	Tibial Punch Handle
17 801-05-015	Tibial Punch, Core
18 801-05-016	Tibial Punch, Large

➤ Reference Guide

INSTRUMENT GUIDE

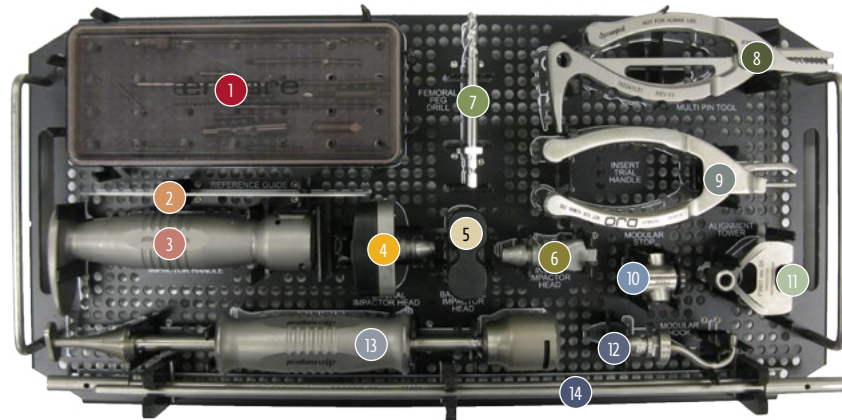

EMPOWR Knee Patella and Tool Kit: Upper Tray

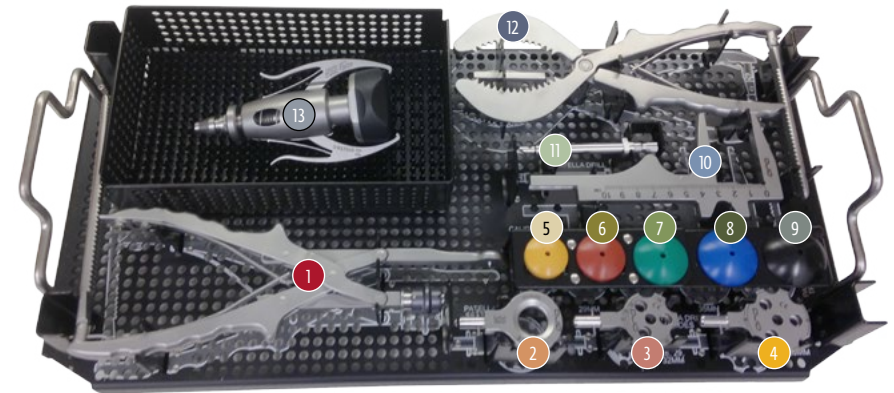

EMPOWR Knee Patella and Tool Kit: Lower Tray

Part Number	Description
800-99-096	Case, EMPOWR Tool Kit
802-01-028	Pin Case
800-02-302	2.5" Quick Headed Bone Pins (QTY 1)
800-02-303	2" Quick Headed Bone Pins (QTY 2)
800-02-304	1.5" Quick Release Bone Pins (QTY 1)
800-01-338	Quick Release Bone Pins (QTY 2)
800-01-339	Quick Release Adapter (QTY 1)
801-04-126	SS, Tibial Bone Pins (QTY 2)
801-01-053	Fixation Pin, Tibia Sizer (QTY 2)
800-05-022	1/8" Quick Connect Drill Bit (QTY 1)
800-05-030	Angel Wing
800-05-024	Impactor Handle

Part Number	Description
800-05-025	Femoral Impactor Head
801-05-029	Baseplate Impactor Head
801-05-030	Insert Impactor Head
800-02-358	Femoral Peg Drill
800-05-029	Multi Pin Tool
801-05-028	Insert Trial Handle
801-05-027	Modular Stop
801-05-031	Alignment Rod Guide
800-05-027	EMPTY (Modular Hook)
800-05-026	Slap Hammer
801-05-026	Alignment Rod

Part Number	Description
802-05-005	Patella Clamp
802-05-006	Patella Seater
802-05-003	Patella Drill Guide, 26/29/32mm
802-05-004	Patella Drill Guide, 35/38mm
802-01-094	Domed Patella Trial, 26mm
802-01-095	Domed Patella Trial, 29mm
802-01-096	Domed Patella Trial, 32mm
802-01-097	Domed Patella Trial, 35mm
802-01-098	Domed Patella Trial, 38mm
802-05-001	Caliper
802-01-092	Patella Drill
802-05-002	Patella Osteotomy Guide
800-05-035	Locking Femoral Impactor

➤ Reference Guide

INSTRUMENT GUIDE

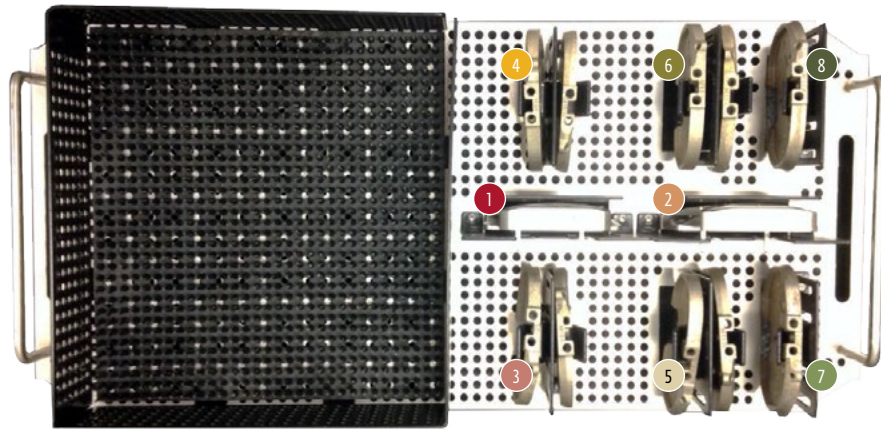

EMPOWR 3D Knee Large Outlier: Upper Tray

Part Number	Description
800-99-103	Case, EMPOWR 3D Large Outlier
1 800-05-020	4-in-1 Cut Block, SZ 10
2 800-05-021	4-in-1 Cut Block, SZ 11
3 801-05-318	Baseplate Trial, 10L
801-05-317	Baseplate Trial, 10L Minus
4 801-05-338	Baseplate Trial, 10R
801-05-337	Baseplate Trial, 10R Minus
5 801-05-320	Baseplate Trial, 11L
801-05-319	Baseplate Trial, 11L Minus
6 801-05-340	Baseplate Trial, 11R
801-05-339	Baseplate Trial, 11R Minus
7 801-05-341	Baseplate Trial, 11L Plus
8 801-05-342	Baseplate Trial, 11R Plus

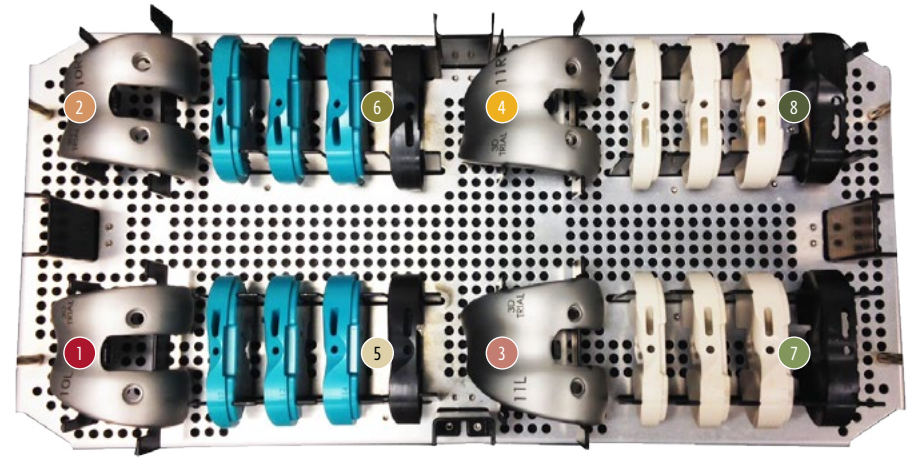

EMPOWR 3D Knee Large Outlier: Lower Tray

Part Number	Description	
1 800-05-310	3D Femoral Trial, 10L	
2 800-05-311	3D Femoral Trial, 11L	
3 800-05-321	3D Femoral Trial, 10R	
4 800-05-322	3D Femoral Trial, 11R	
5	801-05-425	3D Insert Trial, 10L, 10mm
	801-05-426	3D Insert Trial, 10L, 12mm
	801-05-427	3D Insert Trial, 10L, 14mm
	801-05-489	3D Articulating Spacer, SZ 10L
801-05-428	3D Insert Trial, 11L, 10mm	
6	801-05-429	3D Insert Trial, 11L, 12mm
	801-05-430	3D Insert Trial, 11L, 14mm
	801-05-490	3D Articulating Spacer, SZ 11L

Part Number	Description	
801-05-455	3D Insert Trial, 10R, 10mm	
7 801-05-456	3D Insert Trial, 10R, 12mm	
801-05-457	3D Insert Trial, 10R, 14mm	
801-05-499	3D Articulating Spacer, SZ 10R	
8	801-05-458	3D Insert Trial, 11R, 10mm
	801-05-459	3D Insert Trial, 11R, 12mm
	801-05-460	3D Insert Trial, 11R, 14mm
	801-05-500	3D Articulating Spacer, SZ 11R

➤ Reference Guide

INSTRUMENT GUIDE

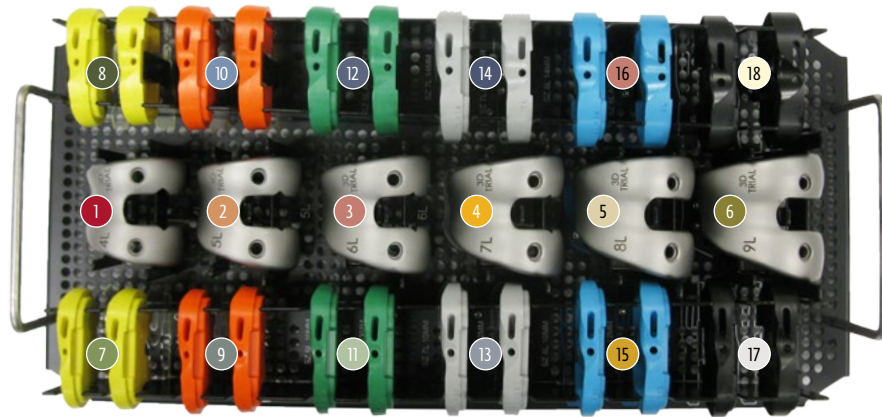

EMPOWR 3D Knee Femoral Trials, Core, Left

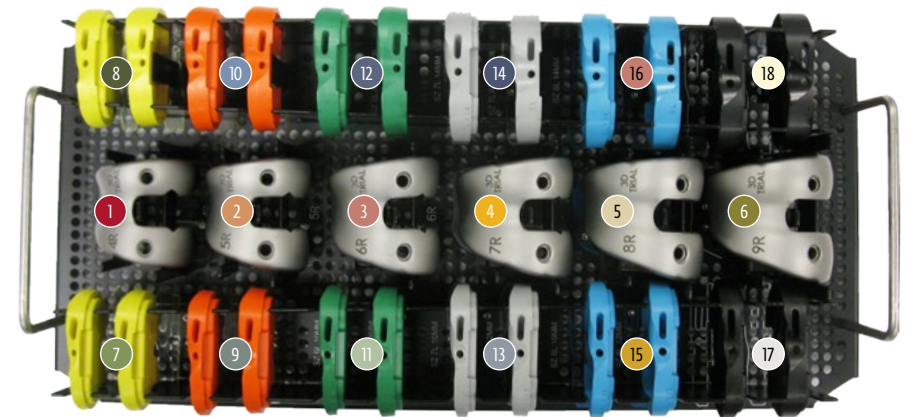

EMPOWR 3D Knee Femoral Trials, Core, Right

Part Number	Description
800-99-098	Case, EMPOWR 3D Femoral Trials, Core, Left
1 800-05-304	3D Femoral Trial, 4L
2 800-05-305	3D Femoral Trial, 5L
3 800-05-306	3D Femoral Trial, 6L
4 800-05-307	3D Femoral Trial, 7L
5 800-05-308	3D Femoral Trial, 8L
6 800-05-309	3D Femoral Trial, 9L
7 801-05-407	3D Insert Trial, 4L, 10mm
801-05-408	3D Insert Trial, 4L, 12mm
8 801-05-409	3D Insert Trial, 4L, 14mm
801-05-483	3D Articulating Spacer, 4L
9 801-05-410	3D Insert Trial, 5L, 10mm
801-05-411	3D Insert Trial, 5L, 12mm
10 801-05-412	3D Insert Trial, 5L, 14mm
801-05-484	3D Articulating Spacer, 5L

Part Number	Description
11 801-05-413	3D Insert Trial, 6L, 10mm
801-05-414	3D Insert Trial, 6L, 12mm
12 801-05-415	3D Insert Trial, 6L, 14mm
801-05-485	3D Articulating Spacer, 6L
13 801-05-416	3D Insert Trial, 7L, 10mm
801-05-417	3D Insert Trial, 7L, 12mm
14 801-05-418	3D Insert Trial, 7L, 14mm
801-05-486	3D Articulating Spacer, 7L
15 801-05-419	3D Insert Trial, 8L, 10mm
801-05-420	3D Insert Trial, 8L, 12mm
16 801-05-421	3D Insert Trial, 8L, 14mm
801-05-487	3D Articulating Spacer, 8L
17 801-05-422	3D Insert Trial, 9L, 10mm
801-05-423	3D Insert Trial, 9L, 12mm
18 801-05-424	3D Insert Trial, 9L, 14mm
801-05-488	3D Articulating Spacer, 9L

Part Number	Description
800-99-099	Case, EMPOWR 3D Femoral Trials, Core, Right
1 800-05-315	3D Femoral Trial, 4R
2 800-05-316	3D Femoral Trial, 5R
3 800-05-317	3D Femoral Trial, 6R
4 800-05-318	3D Femoral Trial, 7R
5 800-05-319	3D Femoral Trial, 8R
6 800-05-320	3D Femoral Trial, 9R
7 801-05-437	3D Insert Trial, 4R, 10mm
801-05-438	3D Insert Trial, 4R, 12mm
8 801-05-439	3D Insert Trial, 4R, 14mm
801-05-493	3D Articulating Spacer, 4R
9 801-05-440	3D Insert Trial, 5R, 10mm
801-05-441	3D Insert Trial, 5R, 12mm
10 801-05-442	3D Insert Trial, 5R, 14mm
801-05-494	3D Articulating Spacer, 5R

Part Number	Description
11 801-05-443	3D Insert Trial, 6R, 10mm
801-05-444	3D Insert Trial, 6R, 12mm
12 801-05-445	3D Insert Trial, 6R, 14mm
801-05-495	3D Articulating Spacer, 6R
13 801-05-446	3D Insert Trial, 7R, 10mm
801-05-447	3D Insert Trial, 7R, 12mm
14 801-05-448	3D Insert Trial, 7R, 14mm
801-05-496	3D Articulating Spacer, 7R
15 801-05-449	3D Insert Trial, 8R, 10mm
801-05-450	3D Insert Trial, 8R, 12mm
16 801-05-451	3D Insert Trial, 8R, 14mm
801-05-497	3D Articulating Spacer, 8R
17 801-05-452	3D Insert Trial, 9R, 10mm
801-05-453	3D Insert Trial, 9R, 12mm
18 801-05-454	3D Insert Trial, 9R, 14mm
801-05-498	3D Articulating Spacer, 9R

➤ Reference Guide

INSTRUMENT GUIDE

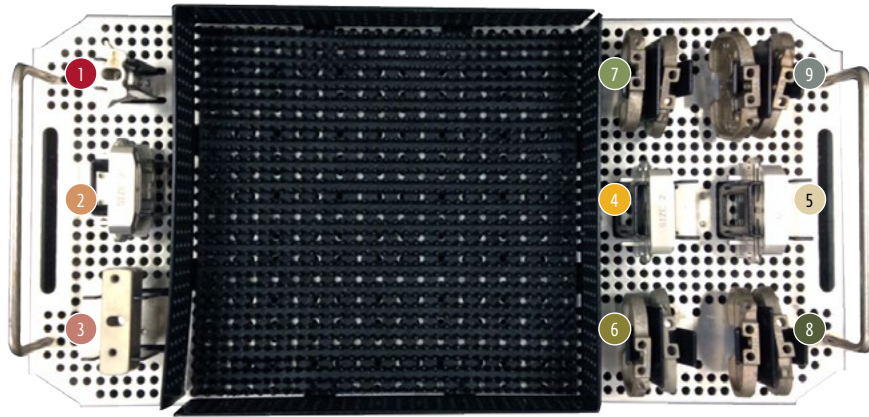

EMPOWR 3D Knee Small Outlier: Upper Tray

	Part Number	Description
	800-99-101	Case, EMPOWR 3D Small Outlier
1	801-05-014	Tibial Punch, Small
2	—	EMPTY
3	800-05-033	2mm Femoral Shift Block
4	800-05-012	4-in-1 Cut Block, SZ 2
5	800-05-013	4-in-1 Cut Block, SZ 3
6	801-05-302	Baseplate Trial, 2L
	801-05-301	Baseplate Trial, 2L Minus
7	801-05-322	Baseplate Trial, 2R
	801-05-321	Baseplate Trial, 2R Minus
8	801-05-304	Baseplate Trial, 3L
	801-05-303	Baseplate Trial, 3L Minus
9	801-05-324	Baseplate Trial, 3R
	801-05-323	Baseplate Trial, 3R Minus

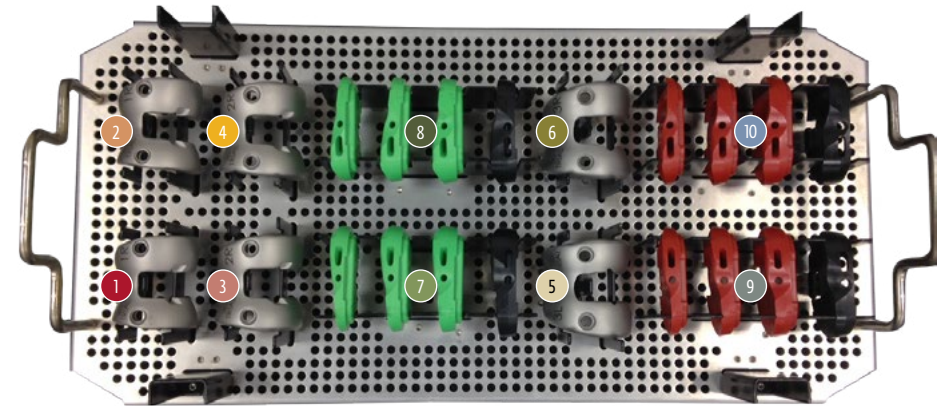

EMPOWR 3D Knee Small Outlier: Lower Tray

	Part Number	Description
1	—	EMPTY
2	—	EMPTY
3	800-05-302	3D Femoral Trial, 2L
4	800-05-303	3D Femoral Trial, 3L
5	800-05-313	3D Femoral Trial, 2R
6	800-05-314	3D Femoral Trial, 3R
	801-05-401	3D Insert Trial, 2L, 10mm
7	801-05-402	3D Insert Trial, 2L, 12mm
	801-05-403	3D Insert Trial, 2L, 14mm
	801-05-481	3D Articulating Spacer, SZ 2L
8	801-05-404	3D Insert Trial, 3L, 10mm
	801-05-405	3D Insert Trial, 3L, 12mm
	801-05-406	3D Insert Trial, 3L, 14mm
	801-05-482	3D Articulating Spacer, SZ 3L

	Part Number	Description
9	801-05-431	3D Insert Trial, 2R, 10mm
	801-05-432	3D Insert Trial, 2R, 12mm
	801-05-433	3D Insert Trial, 2R, 14mm
	801-05-491	3D Articulating Spacer, SZ 2R
10	801-05-434	3D Insert Trial, 3R, 10mm
	801-05-435	3D Insert Trial, 3R, 12mm
	801-05-436	3D Insert Trial, 3R, 14mm
	801-05-492	3D Articulating Spacer, SZ 3R

➤ Reference Guide

INSTRUMENT GUIDE

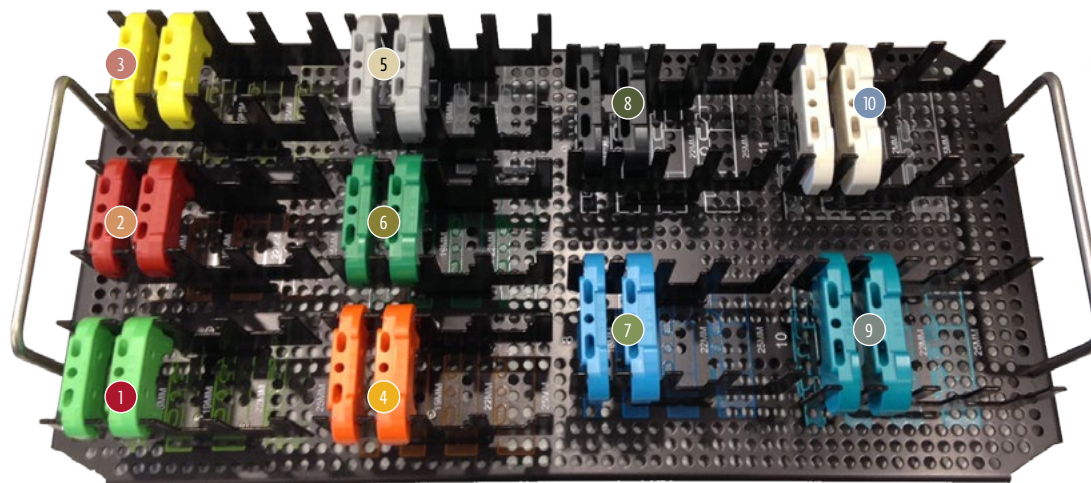

Spacer Trials

	Part Number	Description
	800-99-103	Case, EMPOWR Spacer Trials
1	801-05-461	Insert Spacer Trial, SZ 2, 16mm
	801-05-462	Insert Spacer Trial, SZ 2, 19mm
2	801-05-463	Insert Spacer Trial, SZ 3, 16mm
	801-05-464	Insert Spacer Trial, SZ 3, 19mm
3	801-05-465	Insert Spacer Trial, SZ 4, 16mm
	801-05-466	Insert Spacer Trial, SZ 4, 19mm
4	801-05-467	Insert Spacer Trial, SZ 5, 16mm
	801-05-468	Insert Spacer Trial, SZ 5, 19mm

	Part Number	Description
5	801-05-469	Insert Spacer Trial, SZ 6, 16mm
	801-05-470	Insert Spacer Trial, SZ 6, 19mm
6	801-05-471	Insert Spacer Trial, SZ 7, 16mm
	801-05-472	Insert Spacer Trial, SZ 7, 19mm
7	801-05-473	Insert Spacer Trial, SZ 8, 16mm
	801-05-474	Insert Spacer Trial, SZ 8, 19mm
8	801-05-475	Insert Spacer Trial, SZ 9, 16mm
	801-05-476	Insert Spacer Trial, SZ 9, 19mm

	Part Number	Description
9	801-05-477	Insert Spacer Trial, SZ 10, 16mm
	801-05-478	Insert Spacer Trial, SZ 10, 19mm
10	801-05-479	Insert Spacer Trial, SZ 11, 16mm
	801-05-480	Insert Spacer Trial, SZ 11, 19mm

➤ Reference Guide

INSTRUMENT GUIDE

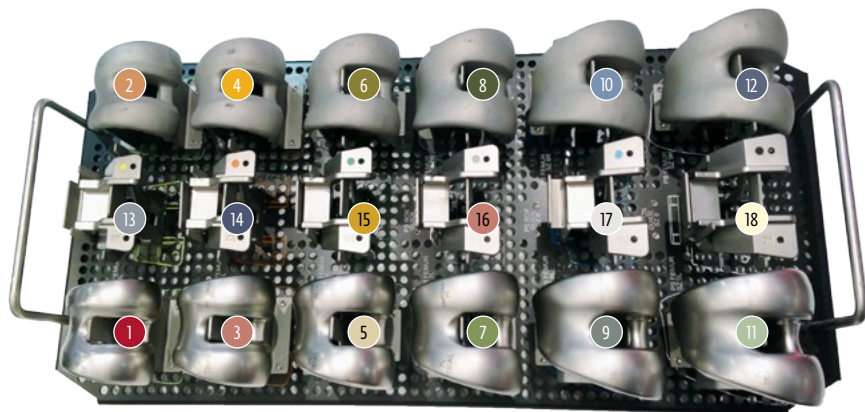

EMPOWR PS Knee Femoral Trials, Core

Part Number	Description
800-99-117	Case, EMPOWR PS Femoral Trials, Core
1 800-05-407	PS Femoral Trial, 4L
2 800-05-408	PS Femoral Trial, 4R
3 800-05-409	PS Femoral Trial, 5L
4 800-05-410	PS Femoral Trial, 5R
5 800-05-411	PS Femoral Trial, 6L
6 800-05-412	PS Femoral Trial, 6R
7 800-05-413	PS Femoral Trial, 7L
8 800-05-414	PS Femoral Trial, 7R
9 800-05-415	PS Femoral Trial, 8L

Part Number	Description
9 800-05-415	PS Femoral Trial, 8L
10 800-05-416	PS Femoral Trial, 8R
11 800-05-417	PS Femoral Trial, 9L
12 800-05-418	PS Femoral Trial, 9R
13 800-05-043	PS Box Cut Guide, Size 4
14 800-05-044	PS Box Cut Guide, Size 5
15 800-05-045	PS Box Cut Guide, Size 6
16 800-05-046	PS Box Cut Guide, Size 7
17 800-05-047	PS Box Cut Guide, Size 8
18 800-05-048	PS Box Cut Guide, Size 9

EMPOWR PS trays are available in two configurations: those with Standard PS Box Cut Guides and those with Captured Box Cut Guides. For reference purposes, the Captured Box Cut Guide part numbers are listed below.

-
- 800-05-052 PS Box Cut Guide with capture, Size 2
 - 800-05-053 PS Box Cut Guide with capture, Size 3
 - 800-05-054 PS Box Cut Guide with capture, Size 4
 - 800-05-055 PS Box Cut Guide with capture, Size 5
 - 800-05-056 PS Box Cut Guide with capture, Size 6
 - 800-05-057 PS Box Cut Guide with capture, Size 7
 - 800-05-058 PS Box Cut Guide with capture, Size 8
 - 800-05-059 PS Box Cut Guide with capture, Size 9
 - 800-05-060 PS Box Cut Guide with capture, Size 10
 - 800-05-061 PS Box Cut Guide with capture, Size 11
-

➤ Reference Guide

INSTRUMENT GUIDE

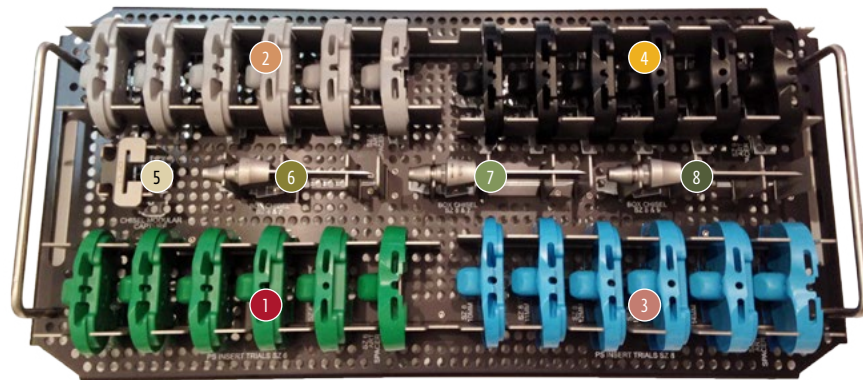

EMPOWR PS Knee Insert Trials, Core: Upper Tray

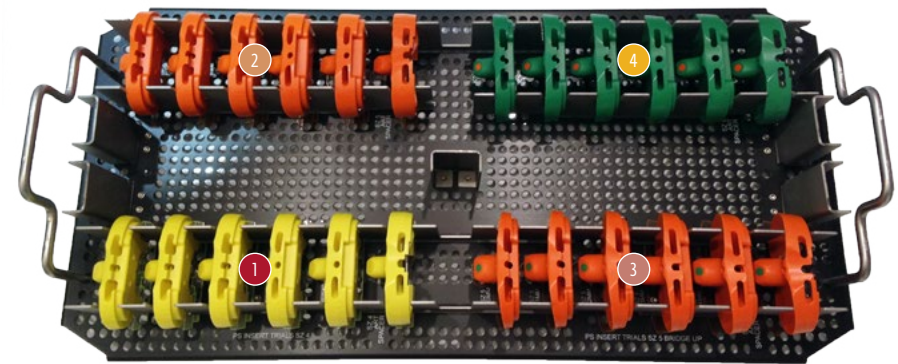

EMPOWR PS Knee Insert Trials, Core: Lower Tray

Part Number	Description
800-99-118	Case, EMPOWR PS Insert Trials, Core
801-05-628	Ps Insert Trial, SZ 6, 10mm
801-05-664	Ps Insert Trial, SZ 6, 11mm
801-05-629	Ps Insert Trial, SZ 6, 12mm
801-05-665	Ps Insert Trial, SZ 6, 13mm
801-05-630	Ps Insert Trial, SZ 6, 14mm
801-05-631	PS Articulating Spacer, SZ 6
801-05-632	Ps Insert Trial, SZ 7, 10mm
801-05-666	Ps Insert Trial, SZ 7, 11mm
801-05-633	Ps Insert Trial, SZ 7, 12mm
801-05-667	Ps Insert Trial, SZ 7, 13mm
801-05-634	Ps Insert Trial, SZ 7, 14mm
801-05-635	PS Articulating Spacer, SZ 7

Part Number	Description
801-05-636	Ps Insert Trial, SZ 8, 10mm
801-05-668	Ps Insert Trial, SZ 8, 11mm
801-05-637	Ps Insert Trial, SZ 8, 12mm
801-05-669	Ps Insert Trial, SZ 8, 13mm
801-05-638	Ps Insert Trial, SZ 8, 14mm
801-05-639	PS Articulating Spacer, SZ 8
801-05-640	Ps Insert Trial, SZ 9, 10mm
801-05-670	Ps Insert Trial, SZ 9, 11mm
801-05-641	Ps Insert Trial, SZ 9, 12mm
801-05-671	Ps Insert Trial, SZ 9, 13mm
801-05-642	Ps Insert Trial, SZ 9, 14mm
801-05-643	PS Articulating Spacer, SZ 9
800-05-067	Modular Capture
800-05-063	Box Cut Guide Chisel, SZ 4 and 5
800-05-064	Box Cut Guide Chisel, SZ 6 and 7
800-05-065	Box Cut Guide Chisel, SZ 8 and 9

Part Number	Description
801-05-612	PS Insert Trial, SZ 4, 10mm
801-05-656	Ps Insert Trial, SZ 4, 11mm
801-05-613	Ps Insert Trial, SZ 4, 12mm
801-05-657	Ps Insert Trial, SZ 4, 13mm
801-05-614	Ps Insert Trial, SZ 4, 14mm
801-05-615	PS Articulating Spacer, SZ 4
801-05-616	Ps Insert Trial, SZ 5, 10mm
801-05-658	Ps Insert Trial, SZ 5, 11mm
801-05-617	Ps Insert Trial, SZ 5, 12mm
801-05-659	Ps Insert Trial, SZ 5, 13mm
801-05-618	Ps Insert Trial, SZ 5, 14mm
801-05-619	PS Articulating Spacer, SZ 5

Part Number	Description
801-05-620	Ps Insert Trial, SZ 5 Bridge Up, 10mm
801-05-660	Ps Insert Trial, SZ 5 Bridge Up, 11mm
801-05-621	Ps Insert Trial, SZ 5 Bridge Up, 12mm
801-05-661	Ps Insert Trial, SZ 5 Bridge Up, 13mm
801-05-622	Ps Insert Trial, SZ 5 Bridge Up, 14mm
801-05-623	PS Articulating Spacer, SZ 5 Bridge Up
801-05-624	Ps Insert Trial, SZ 6 Bridge Down, 10mm
801-05-662	Ps Insert Trial, SZ 6 Bridge Down, 11mm
801-05-625	Ps Insert Trial, SZ 6 Bridge Down, 12mm
801-05-663	Ps Insert Trial, SZ 6 Bridge Down, 13mm
801-05-626	Ps Insert Trial, SZ 6 Bridge Down, 14mm
801-05-627	PS Articulating Spacer, SZ 6 Bridge Down

➤ Reference Guide

INSTRUMENT GUIDE

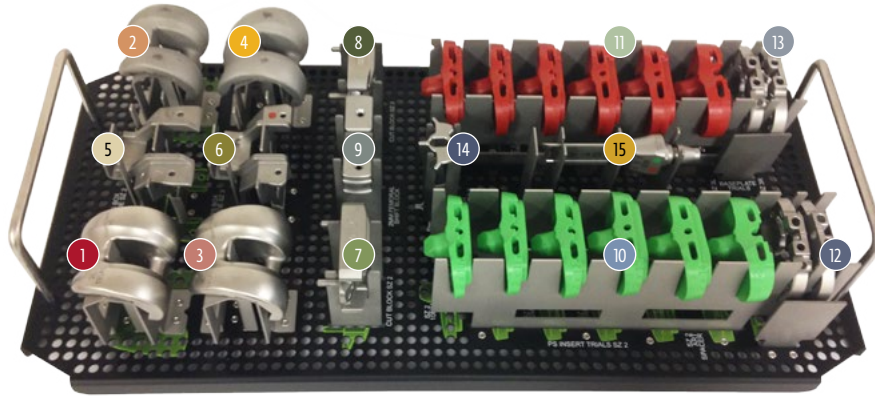

EMPOWR PS Knee Small Outlier

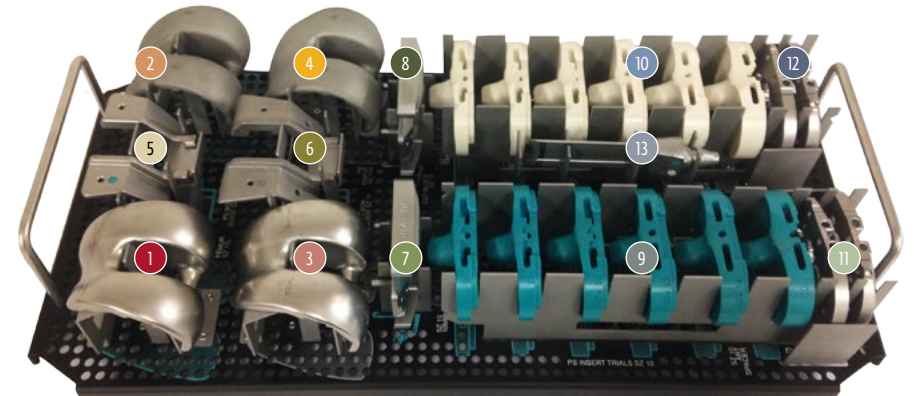

EMPOWR PS Knee Large Outlier

Part Number	Description
800-99-107	Case, EMPOWR PS Small Outlier
1 800-05-403	EMPOWR PS, Femoral Trial, 2L
2 800-05-404	EMPOWR PS, Femoral Trial, 2R
3 800-05-405	EMPOWR PS, Femoral Trial, 3L
4 800-05-406	EMPOWR PS, Femoral Trial, 3R
5 800-05-041	EMPOWR PS Box Cut Guide, Size 2
6 800-05-042	EMPOWR PS Box Cut Guide, Size 3
7 800-05-012	4-in-1 Cut Block, SZ 2
8 800-05-013	4-in-1 Cut Block, SZ 3
9 800-05-033	2mm Femoral Shift Block, 3.2mm
10 801-05-604	PS Insert Trial, SZ 2, 10mm
801-05-652	PS Insert Trial, SZ 2, 11mm
801-05-605	PS Insert Trial, SZ 2, 12mm
801-05-653	PS Insert Trial, SZ 2, 13mm
801-05-606	PS Insert Trial, SZ 2, 14mm
801-05-607	PS Articulating Spacer, SZ 2

Part Number	Description
801-05-608	PS Insert Trial, SZ 3, 10mm
801-05-654	PS Insert Trial, SZ 3, 11mm
11 801-05-609	PS Insert Trial, SZ 3, 12mm
801-05-655	PS Insert Trial, SZ 3, 13mm
801-05-610	PS Insert Trial, SZ 3, 14mm
801-05-611	PS Articulating Spacer, SZ 3
12 801-05-302	Baseplate Trial, 2L
801-05-322	Baseplate Trial, 2R
13 801-05-304	Baseplate Trial, 3L
801-05-324	Baseplate Trial, 3R
14 801-05-014	Tibial Punch, Small
15 800-05-062	Box Cut Guide Chisel, SZ 2 and 3

Part Number	Description
800-99-108	Case, EMPOWR PS Large Outlier
1 800-05-419	PS Femoral Trial, 10L
2 800-05-420	PS Femoral Trial, 10R
3 800-05-421	PS Femoral Trial, 11L
4 800-05-422	PS Femoral Trial, 11R
5 800-05-049	EMPOWR PS Box Cut Guide, Size 10
6 800-05-050	EMPOWR PS Box Cut Guide, Size 11
7 800-05-020	4-in-1 Cut Block, SZ 10
8 800-05-021	4-in-1 Cut Block, SZ 11
9 801-05-644	Ps Insert Trial, SZ 10, 10mm
801-05-672	Ps Insert Trial, SZ 10, 11mm
801-05-645	Ps Insert Trial, SZ 10, 12mm
801-05-673	Ps Insert Trial, SZ 10, 13mm
801-05-646	Ps Insert Trial, SZ 10, 14mm
801-05-647	PS Articulating Spacer, SZ 10

Part Number	Description
801-05-648	Ps Insert Trial, SZ 11, 10mm
801-05-674	Ps Insert Trial, SZ 11, 11mm
10 801-05-649	Ps Insert Trial, SZ 11, 12mm
801-05-675	Ps Insert Trial, SZ 11, 13mm
801-05-650	Ps Insert Trial, SZ 11, 14mm
801-05-651	PS Articulating Spacer, SZ 11
11 801-05-318	Baseplate Trial, 10L
801-05-338	Baseplate Trial, 10R
12 801-05-320	Baseplate Trial, 11L
801-05-340	Baseplate Trial, 11R
13 800-05-066	Box Cut Guide Chisel, SZ 10 and 11

➤ Reference Guide
IMPLANT PART NUMBERS



EMPOWR 3D Knee Femur, Left

PART NUMBER	NON-POROUS FEMURS	SIZE
241-01-102	EMPOWR 3D Femur, Left	2
241-01-103	EMPOWR 3D Femur, Left	3
241-01-104	EMPOWR 3D Femur, Left	4
241-01-105	EMPOWR 3D Femur, Left	5
241-01-106	EMPOWR 3D Femur, Left	6
241-01-107	EMPOWR 3D Femur, Left	7
241-01-108	EMPOWR 3D Femur, Left	8
241-01-109	EMPOWR 3D Femur, Left	9
241-01-110	EMPOWR 3D Femur, Left	10
241-01-111	EMPOWR 3D Femur, Left	11

EMPOWR 3D Knee Femur, Right

PART NUMBER	NON-POROUS FEMURS	SIZE
241-02-102	EMPOWR 3D Femur, Right	2
241-02-103	EMPOWR 3D Femur, Right	3
241-02-104	EMPOWR 3D Femur, Right	4
241-02-105	EMPOWR 3D Femur, Right	5
241-02-106	EMPOWR 3D Femur, Right	6
241-02-107	EMPOWR 3D Femur, Right	7
241-02-108	EMPOWR 3D Femur, Right	8
241-02-109	EMPOWR 3D Femur, Right	9
241-02-110	EMPOWR 3D Femur, Right	10
241-02-111	EMPOWR 3D Femur, Right	11



EMPOWR PS Knee Femur, Left

PART NUMBER	NON-POROUS FEMURS	SIZE
242-01-102	EMPOWR PS Femur, Left	2
242-01-103	EMPOWR PS Femur, Left	3
242-01-104	EMPOWR PS Femur, Left	4
242-01-105	EMPOWR PS Femur, Left	5
242-01-106	EMPOWR PS Femur, Left	6
242-01-107	EMPOWR PS Femur, Left	7
242-01-108	EMPOWR PS Femur, Left	8
242-01-109	EMPOWR PS Femur, Left	9
242-01-110	EMPOWR PS Femur, Left	10
242-01-111	EMPOWR PS Femur, Left	11

EMPOWR PS Knee Femur, Right

PART NUMBER	NON-POROUS FEMURS	SIZE
242-02-102	EMPOWR PS Femur, Right	2
242-02-103	EMPOWR PS Femur, Right	3
242-02-104	EMPOWR PS Femur, Right	4
242-02-105	EMPOWR PS Femur, Right	5
242-02-106	EMPOWR PS Femur, Right	6
242-02-107	EMPOWR PS Femur, Right	7
242-02-108	EMPOWR PS Femur, Right	8
242-02-109	EMPOWR PS Femur, Right	9
242-02-110	EMPOWR PS Femur, Right	10
242-02-111	EMPOWR PS Femur, Right	11

➤ Reference Guide
IMPLANT PART NUMBERS



EMPOWER 3D Knee e+ Insert, Left

PART NUMBER	e+™ INSERTS	SIZE
341-10-702	e+™ Insert, 10mm, Left	2
341-12-702	e+™ Insert, 12mm, Left	2
341-14-702	e+™ Insert, 14mm, Left	2
341-16-702	e+™ Insert, 16mm, Left	2
341-19-702	e+™ Insert, 19mm, Left	2
341-10-703	e+™ Insert, 10mm, Left	3
341-12-703	e+™ Insert, 12mm, Left	3
341-14-703	e+™ Insert, 14mm, Left	3
341-16-703	e+™ Insert, 16mm, Left	3
341-19-703	e+™ Insert, 19mm, Left	3
341-10-704	e+™ Insert, 10mm, Left	4
341-12-704	e+™ Insert, 12mm, Left	4
341-14-704	e+™ Insert, 14mm, Left	4
341-16-704	e+™ Insert, 16mm, Left	4
341-19-704	e+™ Insert, 19mm, Left	4
341-10-705	e+™ Insert, 10mm, Left	5
341-12-705	e+™ Insert, 12mm, Left	5
341-14-705	e+™ Insert, 14mm, Left	5
341-16-705	e+™ Insert, 16mm, Left	5
341-19-705	e+™ Insert, 19mm, Left	5
341-10-706	e+™ Insert, 10mm, Left	6
341-12-706	e+™ Insert, 12mm, Left	6
341-14-706	e+™ Insert, 14mm, Left	6
341-16-706	e+™ Insert, 16mm, Left	6
341-19-706	e+™ Insert, 19mm, Left	6

EMPOWER 3D Knee e+ Insert, Left

PART NUMBER	e+™ INSERTS	SIZE
341-10-707	e+™ Insert, 10mm, Left	7
341-12-707	e+™ Insert, 12mm, Left	7
341-14-707	e+™ Insert, 14mm, Left	7
341-16-707	e+™ Insert, 16mm, Left	7
341-19-707	e+™ Insert, 19mm, Left	7
341-10-708	e+™ Insert, 10mm, Left	8
341-12-708	e+™ Insert, 12mm, Left	8
341-14-708	e+™ Insert, 14mm, Left	8
341-16-708	e+™ Insert, 16mm, Left	8
341-19-708	e+™ Insert, 19mm, Left	8
341-10-709	e+™ Insert, 10mm, Left	9
341-12-709	e+™ Insert, 12mm, Left	9
341-14-709	e+™ Insert, 14mm, Left	9
341-16-709	e+™ Insert, 16mm, Left	9
341-19-709	e+™ Insert, 19mm, Left	9
341-10-710	e+™ Insert, 10mm, Left	10
341-12-710	e+™ Insert, 12mm, Left	10
341-14-710	e+™ Insert, 14mm, Left	10
341-16-710	e+™ Insert, 16mm, Left	10
341-19-710	e+™ Insert, 19mm, Left	10
341-10-711	e+™ Insert, 10mm, Left	11
341-12-711	e+™ Insert, 12mm, Left	11
341-14-711	e+™ Insert, 14mm, Left	11
341-16-711	e+™ Insert, 16mm, Left	11
341-19-711	e+™ Insert, 19mm, Left	11

EMPOWER 3D Knee e+ Insert, Right

PART NUMBER	e+™ INSERTS	SIZE
342-10-702	e+™ Insert, 10mm, Right	2
342-12-702	e+™ Insert, 12mm, Right	2
342-14-702	e+™ Insert, 14mm, Right	2
342-16-702	e+™ Insert, 16mm, Right	2
342-19-702	e+™ Insert, 19mm, Right	2
342-10-703	e+™ Insert, 10mm, Right	3
342-12-703	e+™ Insert, 12mm, Right	3
342-14-703	e+™ Insert, 14mm, Right	3
342-16-703	e+™ Insert, 16mm, Right	3
342-19-703	e+™ Insert, 19mm, Right	3
342-10-704	e+™ Insert, 10mm, Right	4
342-12-704	e+™ Insert, 12mm, Right	4
342-14-704	e+™ Insert, 14mm, Right	4
342-16-704	e+™ Insert, 16mm, Right	4
342-19-704	e+™ Insert, 19mm, Right	4
342-10-705	e+™ Insert, 10mm, Right	5
342-12-705	e+™ Insert, 12mm, Right	5
342-14-705	e+™ Insert, 14mm, Right	5
342-16-705	e+™ Insert, 16mm, Right	5
342-19-705	e+™ Insert, 19mm, Right	5
342-10-706	e+™ Insert, 10mm, Right	6
342-12-706	e+™ Insert, 12mm, Right	6
342-14-706	e+™ Insert, 14mm, Right	6
342-16-706	e+™ Insert, 16mm, Right	6
342-19-706	e+™ Insert, 19mm, Right	6

EMPOWER 3D Knee e+ Insert, Right

PART NUMBER	e+™ INSERTS	SIZE
342-10-707	e+™ Insert, 10mm, Right	7
342-12-707	e+™ Insert, 12mm, Right	7
342-14-707	e+™ Insert, 14mm, Right	7
342-16-707	e+™ Insert, 16mm, Right	7
342-19-707	e+™ Insert, 19mm, Right	7
342-10-708	e+™ Insert, 10mm, Right	8
342-12-708	e+™ Insert, 12mm, Right	8
342-14-708	e+™ Insert, 14mm, Right	8
342-16-708	e+™ Insert, 16mm, Right	8
342-19-708	e+™ Insert, 19mm, Right	8
342-10-709	e+™ Insert, 10mm, Right	9
342-12-709	e+™ Insert, 12mm, Right	9
342-14-709	e+™ Insert, 14mm, Right	9
342-16-709	e+™ Insert, 16mm, Right	9
342-19-709	e+™ Insert, 19mm, Right	9
342-10-710	e+™ Insert, 10mm, Right	10
342-12-710	e+™ Insert, 12mm, Right	10
342-14-710	e+™ Insert, 14mm, Right	10
342-16-710	e+™ Insert, 16mm, Right	10
342-19-710	e+™ Insert, 19mm, Right	10
342-10-711	e+™ Insert, 10mm, Right	11
342-12-711	e+™ Insert, 12mm, Right	11
342-14-711	e+™ Insert, 14mm, Right	11
342-16-711	e+™ Insert, 16mm, Right	11
342-19-711	e+™ Insert, 19mm, Right	11

➤ Reference Guide
IMPLANT PART NUMBERS



EMPOWR PS Knee e+ Insert, Symmetric

PART NO.	e+™ INSERTS	SIZE
343-10-702	PS e+™ Insert, 10mm, Symmetric	2
343-11-702	PS e+™ Insert, 11mm, Symmetric	2
343-12-702	PS e+™ Insert, 12mm, Symmetric	2
343-13-702	PS e+™ Insert, 13mm, Symmetric	2
343-14-702	PS e+™ Insert, 14mm, Symmetric	2
343-16-702	PS e+™ Insert, 16mm, Symmetric	2
343-19-702	PS e+™ Insert, 19mm, Symmetric	2
343-10-703	PS e+™ Insert, 10mm, Symmetric	3
343-11-703	PS e+™ Insert, 11mm, Symmetric	3
343-12-703	PS e+™ Insert, 12mm, Symmetric	3
343-13-703	PS e+™ Insert, 13mm, Symmetric	3
343-14-703	PS e+™ Insert, 14mm, Symmetric	3
343-16-703	PS e+™ Insert, 16mm, Symmetric	3
343-19-703	PS e+™ Insert, 19mm, Symmetric	3
343-10-704	PS e+™ Insert, 10mm, Symmetric	4
343-11-704	PS e+™ Insert, 11mm, Symmetric	4
343-12-704	PS e+™ Insert, 12mm, Symmetric	4
343-13-704	PS e+™ Insert, 13mm, Symmetric	4
343-14-704	PS e+™ Insert, 14mm, Symmetric	4
343-16-704	PS e+™ Insert, 16mm, Symmetric	4
343-19-704	PS e+™ Insert, 19mm, Symmetric	4

PART NO.	e+™ INSERTS	SIZE
343-10-705	PS e+™ Insert, 10mm, Symmetric	5
343-11-705	PS e+™ Insert, 11mm, Symmetric	5
343-12-705	PS e+™ Insert, 12mm, Symmetric	5
343-13-705	PS e+™ Insert, 13mm, Symmetric	5
343-14-705	PS e+™ Insert, 14mm, Symmetric	5
343-16-705	PS e+™ Insert, 16mm, Symmetric	5
343-19-705	PS e+™ Insert, 19mm, Symmetric	5
343-10-755	PS e+™ Insert, 10mm, Symmetric	5 Bridge Up
343-11-755	PS e+™ Insert, 11mm, Symmetric	5 Bridge Up
343-12-755	PS e+™ Insert, 12mm, Symmetric	5 Bridge Up
343-13-755	PS e+™ Insert, 13mm, Symmetric	5 Bridge Up
343-14-755	PS e+™ Insert, 14mm, Symmetric	5 Bridge Up
343-16-755	PS e+™ Insert, 16mm, Symmetric	5 Bridge Up
343-19-755	PS e+™ Insert, 19mm, Symmetric	5 Bridge Up
343-10-766	PS e+™ Insert, 10mm, Symmetric	6 Bridge Down
343-11-766	PS e+™ Insert, 11mm, Symmetric	6 Bridge Down
343-12-766	PS e+™ Insert, 12mm, Symmetric	6 Bridge Down
343-13-766	PS e+™ Insert, 13mm, Symmetric	6 Bridge Down
343-14-766	PS e+™ Insert, 14mm, Symmetric	6 Bridge Down
343-16-766	PS e+™ Insert, 16mm, Symmetric	6 Bridge Down
343-19-766	PS e+™ Insert, 19mm, Symmetric	6 Bridge Down

PART NO.	e+™ INSERTS	SIZE
343-10-706	PS e+™ Insert, 10mm, Symmetric	6
343-11-706	PS e+™ Insert, 11mm, Symmetric	6
343-12-706	PS e+™ Insert, 12mm, Symmetric	6
343-13-706	PS e+™ Insert, 13mm, Symmetric	6
343-14-706	PS e+™ Insert, 14mm, Symmetric	6
343-16-706	PS e+™ Insert, 16mm, Symmetric	6
343-19-706	PS e+™ Insert, 19mm, Symmetric	6
343-10-707	PS e+™ Insert, 10mm, Symmetric	7
343-11-707	PS e+™ Insert, 11mm, Symmetric	7
343-12-707	PS e+™ Insert, 12mm, Symmetric	7
343-13-707	PS e+™ Insert, 13mm, Symmetric	7
343-14-707	PS e+™ Insert, 14mm, Symmetric	7
343-16-707	PS e+™ Insert, 16mm, Symmetric	7
343-19-707	PS e+™ Insert, 19mm, Symmetric	7
343-10-708	PS e+™ Insert, 10mm, Symmetric	8
343-11-708	PS e+™ Insert, 11mm, Symmetric	8
343-12-708	PS e+™ Insert, 12mm, Symmetric	8
343-13-708	PS e+™ Insert, 13mm, Symmetric	8
343-14-708	PS e+™ Insert, 14mm, Symmetric	8
343-16-708	PS e+™ Insert, 16mm, Symmetric	8
343-19-708	PS e+™ Insert, 19mm, Symmetric	8

PART NO.	e+™ INSERTS	SIZE
343-10-709	PS e+™ Insert, 10mm, Symmetric	9
343-11-709	PS e+™ Insert, 11mm, Symmetric	9
343-12-709	PS e+™ Insert, 12mm, Symmetric	9
343-13-709	PS e+™ Insert, 13mm, Symmetric	9
343-14-709	PS e+™ Insert, 14mm, Symmetric	9
343-16-709	PS e+™ Insert, 16mm, Symmetric	9
343-19-709	PS e+™ Insert, 19mm, Symmetric	9
343-10-710	PS e+™ Insert, 10mm, Symmetric	10
343-11-710	PS e+™ Insert, 11mm, Symmetric	10
343-12-710	PS e+™ Insert, 12mm, Symmetric	10
343-13-710	PS e+™ Insert, 13mm, Symmetric	10
343-14-710	PS e+™ Insert, 14mm, Symmetric	10
343-16-710	PS e+™ Insert, 16mm, Symmetric	10
343-19-710	PS e+™ Insert, 19mm, Symmetric	10
343-10-711	PS e+™ Insert, 10mm, Symmetric	11
343-11-711	PS e+™ Insert, 11mm, Symmetric	11
343-12-711	PS e+™ Insert, 12mm, Symmetric	11
343-13-711	PS e+™ Insert, 13mm, Symmetric	11
343-14-711	PS e+™ Insert, 14mm, Symmetric	11
343-16-711	PS e+™ Insert, 16mm, Symmetric	11
343-19-711	PS e+™ Insert, 19mm, Symmetric	11

➤ Reference Guide
IMPLANT PART NUMBERS



EMPOWR Knee Tibia, Left

PART NUMBER	NON-POROUS TIBIA	SIZE
351-01-102	EMPOWR Tibia, Left	2
351-01-103	EMPOWR Tibia, Left	3
351-01-104	EMPOWR Tibia, Left	4
351-01-105	EMPOWR Tibia, Left	5
351-01-106	EMPOWR Tibia, Left	6
351-01-107	EMPOWR Tibia, Left	7
351-01-108	EMPOWR Tibia, Left	8
351-01-109	EMPOWR Tibia, Left	9
351-01-110	EMPOWR Tibia, Left	10
351-01-111	EMPOWR Tibia, Left	11

EMPOWR Knee Tibia, Right

PART NUMBER	NON-POROUS TIBIA	SIZE
351-02-102	EMPOWR Tibia, Right	2
351-02-103	EMPOWR Tibia, Right	3
351-02-104	EMPOWR Tibia, Right	4
351-02-105	EMPOWR Tibia, Right	5
351-02-106	EMPOWR Tibia, Right	6
351-02-107	EMPOWR Tibia, Right	7
351-02-108	EMPOWR Tibia, Right	8
351-02-109	EMPOWR Tibia, Right	9
351-02-110	EMPOWR Tibia, Right	10
351-02-111	EMPOWR Tibia, Right	11

PART NUMBER	NON-POROUS TIBIA	SIZE
351-03-102	EMPOWR 3D Tibia, Left	2 MINUS
351-03-103	EMPOWR 3D Tibia, Left	3 MINUS
351-03-104	EMPOWR 3D Tibia, Left	4 MINUS
351-03-105	EMPOWR 3D Tibia, Left	5 MINUS
351-03-106	EMPOWR 3D Tibia, Left	6 MINUS
351-03-107	EMPOWR 3D Tibia, Left	7 MINUS
351-03-108	EMPOWR 3D Tibia, Left	8 MINUS
351-03-109	EMPOWR 3D Tibia, Left	9 MINUS
351-03-110	EMPOWR 3D Tibia, Left	10 MINUS
351-03-111	EMPOWR 3D Tibia, Left	11 MINUS
351-05-111	EMPOWR 3D Tibia, Left	11 PLUS

PART NUMBER	NON-POROUS TIBIA	SIZE
351-04-102	EMPOWR 3D Tibia, Right	2 MINUS
351-04-103	EMPOWR 3D Tibia, Right	3 MINUS
351-04-104	EMPOWR 3D Tibia, Right	4 MINUS
351-04-105	EMPOWR 3D Tibia, Right	5 MINUS
351-04-106	EMPOWR 3D Tibia, Right	6 MINUS
351-04-107	EMPOWR 3D Tibia, Right	7 MINUS
351-04-108	EMPOWR 3D Tibia, Right	8 MINUS
351-04-109	EMPOWR 3D Tibia, Right	9 MINUS
351-04-110	EMPOWR 3D Tibia, Right	10 MINUS
351-04-111	EMPOWR 3D Tibia, Right	11 MINUS
351-06-111	EMPOWR 3D Tibia, Right	11 PLUS

> Reference Guide
IMPLANT PART NUMBERS



All-Poly Domed Tri-Peg Patellas

PART NUMBER	ALL-POLY DOMED TRI-PEG PATELLAS	SIZE
130-03-726	All-Poly Domed Patella, e™	8 x 26mm
130-03-729	All-Poly Domed Patella, e™	8 x 29mm
130-03-732	All-Poly Domed Patella, e™	8 x 32mm
130-03-735	All-Poly Domed Patella, e™	9 x 35mm
130-03-738	All-Poly Domed Patella, e™	9 x 38mm

> Notes

➤ Instrument Material list

PART NO.	DESCRIPTION	MATERIAL(S)	COLORANT
801-05-612	EMPOWR PS KNEE, INSERT TRIAL, SZ 4, 10MM	POLYPHENYLSULFONE	YELLOW 101C
801-05-656	EMPOWR PS KNEE, INSERT TRIAL, SZ 4, 11MM	POLYPHENYLSULFONE	YELLOW 101C
801-05-613	EMPOWR PS KNEE, INSERT TRIAL, SZ 4, 12MM	POLYPHENYLSULFONE	YELLOW 101C
801-05-657	EMPOWR PS KNEE, INSERT TRIAL, SZ 4, 13MM	POLYPHENYLSULFONE	YELLOW 101C
801-05-614	EMPOWR PS KNEE, INSERT TRIAL, SZ 4, 14MM	POLYPHENYLSULFONE	YELLOW 101C
801-05-615	EMPOWR PS KNEE, ART SURFACE SPACER, SZ 4	POLYPHENYLSULFONE	YELLOW 101C
801-05-616	EMPOWR PS KNEE, INSERT TRIAL, SZ 5, 10MM	POLYPHENYLSULFONE	NEON ORANGE 1505C
801-05-658	EMPOWR PS KNEE, INSERT TRIAL, SZ 5, 11MM	POLYPHENYLSULFONE	NEON ORANGE 1505C
801-05-617	EMPOWR PS KNEE, INSERT TRIAL, SZ 5, 12MM	POLYPHENYLSULFONE	NEON ORANGE 1505C
801-05-659	EMPOWR PS KNEE, INSERT TRIAL, SZ 5, 13MM	POLYPHENYLSULFONE	NEON ORANGE 1505C
801-05-618	EMPOWR PS KNEE, INSERT TRIAL, SZ 5, 14MM	POLYPHENYLSULFONE	NEON ORANGE 1505C
801-05-619	EMPOWR PS KNEE, ART SURFACE SPACER, SZ 5	POLYPHENYLSULFONE	NEON ORANGE 1505C
801-05-620	EMPOWR PS KNEE, INSERT TRIAL, SZ 5 BRIDGE UP, 10MM	POLYPHENYLSULFONE	NEON ORANGE 1505C, VERDE 356C
801-05-660	EMPOWR PS KNEE, INSERT TRIAL, SZ 5 BRIDGE UP, 11MM	POLYPHENYLSULFONE	NEON ORANGE 1505C, VERDE 356C
801-05-621	EMPOWR PS KNEE, INSERT TRIAL, SZ 5 BRIDGE UP, 12MM	POLYPHENYLSULFONE	NEON ORANGE 1505C, VERDE 356C
801-05-661	EMPOWR PS KNEE, INSERT TRIAL, SZ 5 BRIDGE UP, 13MM	POLYPHENYLSULFONE	NEON ORANGE 1505C, VERDE 356C
801-05-622	EMPOWR PS KNEE, INSERT TRIAL, SZ 5 BRIDGE UP, 14MM	POLYPHENYLSULFONE	NEON ORANGE 1505C, VERDE 356C
801-05-623	EMPOWR PS KNEE, ART SURFACE SPACER, SZ 5 BRIDGE UP	POLYPHENYLSULFONE	NEON ORANGE 1505C, VERDE 356C
801-05-624	EMPOWR PS KNEE, INSERT TRIAL, SZ 6 BRIDGE DOWN, 10MM	POLYPHENYLSULFONE	NEON ORANGE 1505C, VERDE 356C
801-05-662	EMPOWR PS KNEE, INSERT TRIAL, SZ 6 BRIDGE DOWN, 11MM	POLYPHENYLSULFONE	NEON ORANGE 1505C, VERDE 356C
801-05-625	EMPOWR PS KNEE, INSERT TRIAL, SZ 6 BRIDGE DOWN, 12MM	POLYPHENYLSULFONE	NEON ORANGE 1505C, VERDE 356C
801-05-663	EMPOWR PS KNEE, INSERT TRIAL, SZ 6 BRIDGE DOWN, 13MM	POLYPHENYLSULFONE	NEON ORANGE 1505C, VERDE 356C
801-05-626	EMPOWR PS KNEE, INSERT TRIAL, SZ 6 BRIDGEDOWN, 14MM	POLYPHENYLSULFONE	NEON ORANGE 1505C, VERDE 356C
801-05-627	EMPOWR PS KNEE, ART SURFACE SPACER, SZ 6 BRIDGE DOWN	POLYPHENYLSULFONE	NEON ORANGE 1505C, VERDE 356C
801-05-628	EMPOWR PS KNEE, INSERT TRIAL, SZ 6, 10MM	POLYPHENYLSULFONE	VERDE 356C
801-05-664	EMPOWR PS KNEE, INSERT TRIAL, SZ 6, 11MM	POLYPHENYLSULFONE	VERDE 356C
801-05-629	EMPOWR PS KNEE, INSERT TRIAL, SZ 6, 12MM	POLYPHENYLSULFONE	VERDE 356C
801-05-665	EMPOWR PS KNEE, INSERT TRIAL, SZ 6, 13MM	POLYPHENYLSULFONE	VERDE 356C
801-05-630	EMPOWR PS KNEE, INSERT TRIAL, SZ 6, 14MM	POLYPHENYLSULFONE	VERDE 356C
801-05-631	EMPOWR PS KNEE, ART SURFACE SPACER, SZ 6	POLYPHENYLSULFONE	VERDE 356C
801-05-632	EMPOWR PS KNEE, INSERT TRIAL, SZ 7, 10MM	POLYPHENYLSULFONE	GREY 7C
801-05-666	EMPOWR PS KNEE, INSERT TRIAL, SZ 7, 11MM	POLYPHENYLSULFONE	GREY 7C
801-05-633	EMPOWR PS KNEE, INSERT TRIAL, SZ 7, 12MM	POLYPHENYLSULFONE	GREY 7C
801-05-667	EMPOWR PS KNEE, INSERT TRIAL, SZ 7, 13MM	POLYPHENYLSULFONE	GREY 7C
801-05-634	EMPOWR PS KNEE, INSERT TRIAL, SZ 7, 14MM	POLYPHENYLSULFONE	GREY 7C
801-05-635	EMPOWR PS KNEE, ART SURFACE SPACER, SZ 7	POLYPHENYLSULFONE	GREY 7C
801-05-636	EMPOWR PS KNEE, INSERT TRIAL, SZ 8, 10MM	POLYPHENYLSULFONE	WINDY BLUE 7459C
801-05-668	EMPOWR PS KNEE, INSERT TRIAL, SZ 8, 11MM	POLYPHENYLSULFONE	WINDY BLUE 7459C
801-05-637	EMPOWR PS KNEE, INSERT TRIAL, SZ 8, 12MM	POLYPHENYLSULFONE	WINDY BLUE 7459C
801-05-669	EMPOWR PS KNEE, INSERT TRIAL, SZ 8, 13MM	POLYPHENYLSULFONE	WINDY BLUE 7459C
801-05-638	EMPOWR PS KNEE, INSERT TRIAL, SZ 8, 14MM	POLYPHENYLSULFONE	WINDY BLUE 7459C

PART NO.	DESCRIPTION	MATERIAL(S)	COLORANT
801-05-639	EMPOWR PS KNEE, ART SURFACE SPACER, SZ 8	POLYPHENYLSULFONE	WINDY BLUE 7459C
801-05-640	EMPOWR PS KNEE, INSERT TRIAL, SZ 9, 10MM	POLYPHENYLSULFONE	BLACK 7547C
801-05-670	EMPOWR PS KNEE, INSERT TRIAL, SZ 9, 11MM	POLYPHENYLSULFONE	BLACK 7547C
801-05-641	EMPOWR PS KNEE, INSERT TRIAL, SZ 9, 12MM	POLYPHENYLSULFONE	BLACK 7547C
801-05-671	EMPOWR PS KNEE, INSERT TRIAL, SZ 9, 13MM	POLYPHENYLSULFONE	BLACK 7547C
801-05-642	EMPOWR PS KNEE, INSERT TRIAL, SZ 9, 14MM	POLYPHENYLSULFONE	BLACK 7547C
801-05-643	EMPOWR PS KNEE, ART SURFACE SPACER, SZ 9	POLYPHENYLSULFONE	BLACK 7547C
800-05-063	EMPOWR BOX CUT GUIDE CHISEL, SZ 4 AND 5	STAINLESS STEEL/POLYPHENYLSULFONE	YELLOW 101C, NEON ORANGE 1505C
800-05-064	EMPOWR BOX CUT GUIDE CHISEL, SZ 6 AND 7	STAINLESS STEEL/POLYPHENYLSULFONE	VERDE 356C, GREY 7C
800-05-065	EMPOWR BOX CUT GUIDE CHISEL, SZ 8 AND 9	STAINLESS STEEL/POLYPHENYLSULFONE	WINDY BLUE 7459C, BLACK 7547C
800-05-067	EMPOWR MODULAR CHISEL GUIDE	STAINLESS STEEL	NONE
800-05-407	EMPOWR PS KNEE, FEMORAL TRIAL, 4L	COBALT CHROME	NONE
800-05-408	EMPOWR PS KNEE, FEMORAL TRIAL, 4R	COBALT CHROME	NONE
800-05-409	EMPOWR PS KNEE, FEMORAL TRIAL, 5L	COBALT CHROME/POLYPHENYLSULFONE	NEON ORANGE 1505C
800-05-410	EMPOWR PS KNEE, FEMORAL TRIAL, 5R	COBALT CHROME/POLYPHENYLSULFONE	NEON ORANGE 1505C
800-05-411	EMPOWR PS KNEE, FEMORAL TRIAL, 6L	COBALT CHROME/POLYPHENYLSULFONE	VERDE 356C
800-05-412	EMPOWR PS KNEE, FEMORAL TRIAL, 6R	COBALT CHROME/POLYPHENYLSULFONE	VERDE 356C
800-05-413	EMPOWR PS KNEE, FEMORAL TRIAL, 7L	COBALT CHROME	NONE
800-05-414	EMPOWR PS KNEE, FEMORAL TRIAL, 7R	COBALT CHROME	NONE
800-05-415	EMPOWR PS KNEE, FEMORAL TRIAL, 8L	COBALT CHROME	NONE
800-05-416	EMPOWR PS KNEE, FEMORAL TRIAL, 8R	COBALT CHROME	NONE
800-05-417	EMPOWR PS KNEE, FEMORAL TRIAL, 9L	COBALT CHROME	NONE
800-05-418	EMPOWR PS KNEE, FEMORAL TRIAL, 9R	COBALT CHROME	NONE
800-05-043	EMPOWR PS KNEE BOX CUT GUIDE, SIZE 4	STAINLESS STEEL/POLYPHENYLSULFONE	YELLOW 101C
800-05-044	EMPOWR PS KNEE BOX CUT GUIDE, SIZE 5	STAINLESS STEEL/POLYPHENYLSULFONE	NEON ORANGE 1505C
800-05-045	EMPOWR PS KNEE BOX CUT GUIDE, SIZE 6	STAINLESS STEEL/POLYPHENYLSULFONE	VERDE 356C
800-05-046	EMPOWR PS KNEE BOX CUT GUIDE, SIZE 7	STAINLESS STEEL/POLYPHENYLSULFONE	GREY 7C
800-05-047	EMPOWR PS KNEE BOX CUT GUIDE, SIZE 8	STAINLESS STEEL/POLYPHENYLSULFONE	WINDY BLUE 7459C
800-05-048	EMPOWR PS KNEE BOX CUT GUIDE, SIZE 9	STAINLESS STEEL/POLYPHENYLSULFONE	BLACK 7547C
800-05-054	EMPOWR PS KNEE BOX CUT GUIDE WITH CAPTURE, SIZE 4	STAINLESS STEEL/POLYPHENYLSULFONE	YELLOW 101C
800-05-055	EMPOWR PS KNEE BOX CUT GUIDE WITH CAPTURE, SIZE 5	STAINLESS STEEL/POLYPHENYLSULFONE	NEON ORANGE 1505C
800-05-056	EMPOWR PS KNEE BOX CUT GUIDE WITH CAPTURE, SIZE 6	STAINLESS STEEL/POLYPHENYLSULFONE	VERDE 356C
800-05-057	EMPOWR PS KNEE BOX CUT GUIDE WITH CAPTURE, SIZE 7	STAINLESS STEEL/POLYPHENYLSULFONE	GREY 7C
800-05-058	EMPOWR PS KNEE BOX CUT GUIDE WITH CAPTURE, SIZE 8	STAINLESS STEEL/POLYPHENYLSULFONE	WINDY BLUE 7459C
800-05-059	EMPOWR PS KNEE BOX CUT GUIDE WITH CAPTURE, SIZE 9	STAINLESS STEEL/POLYPHENYLSULFONE	BLACK 7547C
800-05-419	EMPOWR PS KNEE, FEMORAL TRIAL, 10L	COBALT CHROME	NONE
800-05-420	EMPOWR PS KNEE, FEMORAL TRIAL, 10R	COBALT CHROME	NONE
800-05-421	EMPOWR PS KNEE, FEMORAL TRIAL, 11L	COBALT CHROME	NONE
800-05-422	EMPOWR PS KNEE, FEMORAL TRIAL, 11R	COBALT CHROME	NONE
801-05-644	EMPOWR PS KNEE, INSERT TRIAL, SZ 10, 10MM	POLYPHENYLSULFONE	AQUA 326C
801-05-672	EMPOWR PS KNEE, INSERT TRIAL, SZ 10, 11MM	POLYPHENYLSULFONE	AQUA 326C

➤ Instrument Material list

PART NO.	DESCRIPTION	MATERIAL(S)	COLORANT
801-05-645	EMPOWR PS KNEE, INSERT TRIAL, SZ 10, 12MM	POLYPHENYLSULFONE	AQUA 326C
801-05-673	EMPOWR PS KNEE, INSERT TRIAL, SZ 10, 13MM	POLYPHENYLSULFONE	AQUA 326C
801-05-646	EMPOWR PS KNEE, INSERT TRIAL, SZ 10, 14MM	POLYPHENYLSULFONE	AQUA 326C
801-05-647	EMPOWR PS KNEE, ART SURFACE SPACER, SZ 10	POLYPHENYLSULFONE	AQUA 326C
801-05-648	EMPOWR PS KNEE, INSERT TRIAL, SZ 11, 10MM	POLYPHENYLSULFONE	BEIGE 466C
801-05-674	EMPOWR PS KNEE, INSERT TRIAL, SZ 11, 11MM	POLYPHENYLSULFONE	BEIGE 466C
801-05-649	EMPOWR PS KNEE, INSERT TRIAL, SZ 11, 12MM	POLYPHENYLSULFONE	BEIGE 466C
801-05-675	EMPOWR PS KNEE, INSERT TRIAL, SZ 11, 13MM	POLYPHENYLSULFONE	BEIGE 466C
801-05-650	EMPOWR PS KNEE, INSERT TRIAL, SZ 11, 14MM	POLYPHENYLSULFONE	BEIGE 466C
801-05-651	EMPOWR PS KNEE, ART SURFACE SPACER, SZ 11	POLYPHENYLSULFONE	BEIGE 466C
800-05-049	EMPOWR PS KNEE BOX CUT GUIDE, SIZE 10	STAINLESS STEEL/POLYPHENYLSULFONE	AQUA 326C
800-05-050	EMPOWR PS KNEE BOX CUT GUIDE, SIZE 11	STAINLESS STEEL/POLYPHENYLSULFONE	BEIGE 466C
800-05-060	EMPOWR PS KNEE BOX CUT GUIDE WITH CAPTURE, SIZE 10	STAINLESS STEEL/POLYPHENYLSULFONE	AQUA 326C
800-05-061	EMPOWR PS KNEE BOX CUT GUIDE WITH CAPTURE, SIZE 11	STAINLESS STEEL/POLYPHENYLSULFONE	BEIGE 466C
800-05-066	EMPOWR BOX CUT GUIDE CHISEL, SZ 10 AND 11	STAINLESS STEEL/POLYPHENYLSULFONE	AQUA 326C, BEIGE 466C
800-05-403	EMPOWR PS KNEE, FEMORAL TRIAL, 2L	COBALT CHROME	NONE
800-05-404	EMPOWR PS KNEE, FEMORAL TRIAL, 2R	COBALT CHROME	NONE
800-05-405	EMPOWR PS KNEE, FEMORAL TRIAL, 3L	COBALT CHROME	NONE
800-05-406	EMPOWR PS KNEE, FEMORAL TRIAL, 3R	COBALT CHROME	NONE
801-05-604	EMPOWR PS KNEE, INSERT TRIAL, SZ 2, 10MM	POLYPHENYLSULFONE	LIME GREEN 375C
801-05-652	EMPOWR PS KNEE, INSERT TRIAL, SZ 2, 11MM	POLYPHENYLSULFONE	LIME GREEN 375C
801-05-605	EMPOWR PS KNEE, INSERT TRIAL, SZ 2, 12MM	POLYPHENYLSULFONE	LIME GREEN 375C
801-05-653	EMPOWR PS KNEE, INSERT TRIAL, SZ 2, 13MM	POLYPHENYLSULFONE	LIME GREEN 375C
801-05-606	EMPOWR PS KNEE, INSERT TRIAL, SZ 2, 14MM	POLYPHENYLSULFONE	LIME GREEN 375C
801-05-607	EMPOWR PS KNEE, ART SURFACE SPACER, SZ 2	POLYPHENYLSULFONE	LIME GREEN 375C
801-05-608	EMPOWR PS KNEE, INSERT TRIAL, SZ 3, 10MM	POLYPHENYLSULFONE	RUST 174C
801-05-654	EMPOWR PS KNEE, INSERT TRIAL, SZ 3, 11MM	POLYPHENYLSULFONE	RUST 174C
801-05-609	EMPOWR PS KNEE, INSERT TRIAL, SZ 3, 12MM	POLYPHENYLSULFONE	RUST 174C
801-05-655	EMPOWR PS KNEE, INSERT TRIAL, SZ 3, 13MM	POLYPHENYLSULFONE	RUST 174C
801-05-610	EMPOWR PS KNEE, INSERT TRIAL, SZ 3, 14MM	POLYPHENYLSULFONE	RUST 174C
801-05-611	EMPOWR PS KNEE, ART SURFACE SPACER, SZ 3	POLYPHENYLSULFONE	RUST 174C
800-05-041	EMPOWR PS KNEE BOX CUT GUIDE, SIZE 2	STAINLESS STEEL/POLYPHENYLSULFONE	LIME GREEN 375C
800-05-042	EMPOWR PS KNEE BOX CUT GUIDE, SIZE 3	STAINLESS STEEL/POLYPHENYLSULFONE	RUST 174C
800-05-052	EMPOWR PS KNEE BOX CUT GUIDE WITH CAPTURE, SIZE 2	STAINLESS STEEL/POLYPHENYLSULFONE	LIME GREEN 375C
800-05-053	EMPOWR PS KNEE BOX CUT GUIDE WITH CAPTURE, SIZE 3	STAINLESS STEEL/POLYPHENYLSULFONE	RUST 174C
800-05-062	EMPOWR BOX CUT GUIDE CHISEL, SZ 2 AND 3	STAINLESS STEEL/POLYPHENYLSULFONE	LIME GREEN 375C, RUST 174C
800-05-028	EMPOWR, FEMORAL SIZER STYLUS 2	STAINLESS STEEL	NONE
800-05-034	EMPOWR, FEMORAL SIZER 2	STAINLESS STEEL	NONE
800-05-011	EMPOWR, DRF FEMORAL SPEEDBLOCK, SZ 1	STAINLESS STEEL	NONE
800-05-012	EMPOWR, DRF FEMORAL SPEEDBLOCK, SZ 2	STAINLESS STEEL	NONE
800-05-013	EMPOWR, DRF FEMORAL SPEEDBLOCK, SZ 3	STAINLESS STEEL	NONE

PART NO.	DESCRIPTION	MATERIAL(S)	COLORANT
800-05-014	EMPOWR, DRF FEMORAL SPEEDBLOCK, SZ 4	STAINLESS STEEL	NONE
800-05-015	EMPOWR, DRF FEMORAL SPEEDBLOCK, SZ 5	STAINLESS STEEL	NONE
800-05-016	EMPOWR, DRF FEMORAL SPEEDBLOCK, SZ 6	STAINLESS STEEL	NONE
800-05-017	EMPOWR, DRF FEMORAL SPEEDBLOCK, SZ 7	STAINLESS STEEL	NONE
800-05-018	EMPOWR, DRF FEMORAL SPEEDBLOCK, SZ 8	STAINLESS STEEL	NONE
800-05-019	EMPOWR, DRF FEMORAL SPEEDBLOCK, SZ 9	STAINLESS STEEL	NONE
800-05-020	EMPOWR, DRF FEMORAL SPEEDBLOCK, SZ 10	STAINLESS STEEL	NONE
800-05-021	EMPOWR, DRF FEMORAL SPEEDBLOCK, SZ 11	STAINLESS STEEL	NONE
800-05-028	EMPOWR, FEMORAL HOLDER IMPACTOR/EXTRACTOR	STAINLESS STEEL	NONE
800-05-032	EMPOWR, FEMORAL PEG SPIKE	STAINLESS STEEL	NONE
800-05-101	EMPOWR, GAP BALANCER, FEMORAL SIZER INSTRUMENT	STAINLESS STEEL	NONE
800-05-302	EMPOWR 3D, FEMORAL TRIAL, 2L	COBALT CHROME	NONE
800-05-303	EMPOWR 3D, FEMORAL TRIAL, 3L	COBALT CHROME	NONE
800-05-304	EMPOWR 3D, FEMORAL TRIAL, 4L	COBALT CHROME	NONE
800-05-305	EMPOWR 3D, FEMORAL TRIAL, 5L	COBALT CHROME	NONE
800-05-306	EMPOWR 3D, FEMORAL TRIAL, 6L	COBALT CHROME	NONE
800-05-307	EMPOWR 3D, FEMORAL TRIAL, 7L	COBALT CHROME	NONE
800-05-308	EMPOWR 3D, FEMORAL TRIAL, 8L	COBALT CHROME	NONE
800-05-309	EMPOWR 3D, FEMORAL TRIAL, 9L	COBALT CHROME	NONE
800-05-310	EMPOWR 3D, FEMORAL TRIAL, 10L	COBALT CHROME	NONE
800-05-311	EMPOWR 3D, FEMORAL TRIAL, 11L	COBALT CHROME	NONE
800-05-312	EMPOWR 3D, FEMORAL TRIAL, 1R	COBALT CHROME	NONE
800-05-313	EMPOWR 3D, FEMORAL TRIAL, 2R	COBALT CHROME	NONE
800-05-314	EMPOWR 3D, FEMORAL TRIAL, 3R	COBALT CHROME	NONE
800-05-315	EMPOWR 3D, FEMORAL TRIAL, 4R	COBALT CHROME	NONE
800-05-316	EMPOWR 3D, FEMORAL TRIAL, 5R	COBALT CHROME	NONE
800-05-317	EMPOWR 3D, FEMORAL TRIAL, 6R	COBALT CHROME	NONE
800-05-318	EMPOWR 3D, FEMORAL TRIAL, 7R	COBALT CHROME	NONE
800-05-319	EMPOWR 3D, FEMORAL TRIAL, 8R	COBALT CHROME	NONE
800-05-320	EMPOWR 3D, FEMORAL TRIAL, 9R	COBALT CHROME	NONE
800-05-321	EMPOWR 3D, FEMORAL TRIAL, 10R	COBALT CHROME	NONE
800-05-322	EMPOWR 3D, FEMORAL TRIAL, 11R	COBALT CHROME	NONE
801-05-013	EMPOWR, TIBIAL STEM REAMER - FIN	STAINLESS STEEL	NONE
801-05-014	EMPOWR, MODULAR FIN BROACH, SMALL	STAINLESS STEEL	NONE
801-05-015	EMPOWR, MODULAR FIN BROACH, CORE	STAINLESS STEEL	NONE
801-05-016	EMPOWR, MODULAR FIN BROACH, LARGE	STAINLESS STEEL	NONE
801-05-024	EMPOWR, INSERT SEATER	STAINLESS STEEL	NONE
801-05-028	EMPOWR, TIBIAL INSERT TRIAL INSERTION HANDLE	STAINLESS STEEL	NONE
801-05-029	EMPOWR, TIBIAL BASEPLATE IMPACTOR HEAD	STAINLESS STEEL/POLYPHENYLSULFONE	BLACK 7547C
801-05-030	EMPOWR, TIBIAL INSERT IMPACTOR HEAD	STAINLESS STEEL/POLYPHENYLSULFONE	BLACK 7547C
801-05-101	EMPOWR, EXT GAP BLOCK, 19MM	POLYPHENYLSULFONE	BLACK 7547C

➤ Instrument Material list

PART NO.	DESCRIPTION	MATERIAL(S)	COLORANT
801-05-102	EMPOWR, EXT GAP BLOCK, 21MM	POLYPHENYLSULFONE	BLACK 7547C
801-05-103	EMPOWR, EXT GAP BLOCK, 23MM	POLYPHENYLSULFONE	BLACK 7547C
801-05-104	EMPOWR, EXT GAP BLOCK, 25MM	POLYPHENYLSULFONE	BLACK 7547C
801-05-105	EMPOWR, EXT GAP BLOCK, 28MM	POLYPHENYLSULFONE	BLACK 7547C
801-05-301	EMPOWR, FIN BASEPLATE TRIAL, 2L MINUS	STAINLESS STEEL/POLYPHENYLSULFONE	LIME GREEN 375C
801-05-302	EMPOWR, FIN BASEPLATE TRIAL, 2L	STAINLESS STEEL/POLYPHENYLSULFONE	LIME GREEN 375C
801-05-303	EMPOWR, FIN BASEPLATE TRIAL, 3L MINUS	STAINLESS STEEL/POLYPHENYLSULFONE	RUST 174C
801-05-304	EMPOWR, FIN BASEPLATE TRIAL, 3L	STAINLESS STEEL/POLYPHENYLSULFONE	RUST 174C
801-05-305	EMPOWR, FIN BASEPLATE TRIAL, 4L MINUS	STAINLESS STEEL/POLYPHENYLSULFONE	YELLOW 101C
801-05-306	EMPOWR, FIN BASEPLATE TRIAL, 4L	STAINLESS STEEL/POLYPHENYLSULFONE	YELLOW 101C
801-05-307	EMPOWR, FIN BASEPLATE TRIAL, 5L MINUS	STAINLESS STEEL/POLYPHENYLSULFONE	NEON ORANGE 1505C
801-05-308	EMPOWR, FIN BASEPLATE TRIAL, 5L	STAINLESS STEEL/POLYPHENYLSULFONE	NEON ORANGE 1505C
801-05-309	EMPOWR, FIN BASEPLATE TRIAL, 6L MINUS	STAINLESS STEEL/POLYPHENYLSULFONE	VERDE 356C
801-05-310	EMPOWR, FIN BASEPLATE TRIAL, 6L	STAINLESS STEEL/POLYPHENYLSULFONE	VERDE 356C
801-05-311	EMPOWR, FIN BASEPLATE TRIAL, 7L MINUS	STAINLESS STEEL/POLYPHENYLSULFONE	GREY 7C
801-05-312	EMPOWR, FIN BASEPLATE TRIAL, 7L	STAINLESS STEEL/POLYPHENYLSULFONE	GREY 7C
801-05-313	EMPOWR, FIN BASEPLATE TRIAL, 8L MINUS	STAINLESS STEEL/POLYPHENYLSULFONE	WINDY BLUE 7459C
801-05-314	EMPOWR, FIN BASEPLATE TRIAL, 8L	STAINLESS STEEL/POLYPHENYLSULFONE	WINDY BLUE 7459C
801-05-315	EMPOWR, FIN BASEPLATE TRIAL, 9L MINUS	STAINLESS STEEL/POLYPHENYLSULFONE	BLACK 7547C
801-05-316	EMPOWR, FIN BASEPLATE TRIAL, 9L	STAINLESS STEEL/POLYPHENYLSULFONE	BLACK 7547C
801-05-317	EMPOWR, FIN BASEPLATE TRIAL, 10L MINUS	STAINLESS STEEL/POLYPHENYLSULFONE	AQUA 326C
801-05-318	EMPOWR, FIN BASEPLATE TRIAL, 10L	STAINLESS STEEL/POLYPHENYLSULFONE	AQUA 326C
801-05-319	EMPOWR, FIN BASEPLATE TRIAL, 11L MINUS	STAINLESS STEEL/POLYPHENYLSULFONE	BONE 7527C
801-05-320	EMPOWR, FIN BASEPLATE TRIAL, 11L	STAINLESS STEEL/POLYPHENYLSULFONE	BONE 7527C
801-05-321	EMPOWR, FIN BASEPLATE TRIAL, 2R MINUS	STAINLESS STEEL/POLYPHENYLSULFONE	LIME GREEN 375C
801-05-322	EMPOWR, FIN BASEPLATE TRIAL, 2R	STAINLESS STEEL/POLYPHENYLSULFONE	LIME GREEN 375C
801-05-323	EMPOWR, FIN BASEPLATE TRIAL, 3R MINUS	STAINLESS STEEL/POLYPHENYLSULFONE	RUST 174C
801-05-324	EMPOWR, FIN BASEPLATE TRIAL, 3R	STAINLESS STEEL/POLYPHENYLSULFONE	RUST 174C
801-05-325	EMPOWR, FIN BASEPLATE TRIAL, 4R MINUS	STAINLESS STEEL/POLYPHENYLSULFONE	YELLOW 101C
801-05-326	EMPOWR, FIN BASEPLATE TRIAL, 4R	STAINLESS STEEL/POLYPHENYLSULFONE	YELLOW 101C
801-05-327	EMPOWR, FIN BASEPLATE TRIAL, 5R MINUS	STAINLESS STEEL/POLYPHENYLSULFONE	NEON ORANGE 1505C
801-05-328	EMPOWR, FIN BASEPLATE TRIAL, 5R	STAINLESS STEEL/POLYPHENYLSULFONE	NEON ORANGE 1505C
801-05-329	EMPOWR, FIN BASEPLATE TRIAL, 6R MINUS	STAINLESS STEEL/POLYPHENYLSULFONE	VERDE 356C
801-05-330	EMPOWR, FIN BASEPLATE TRIAL, 6R	STAINLESS STEEL/POLYPHENYLSULFONE	VERDE 356C
801-05-331	EMPOWR, FIN BASEPLATE TRIAL, 7R MINUS	STAINLESS STEEL/POLYPHENYLSULFONE	GREY 7C
801-05-332	EMPOWR, FIN BASEPLATE TRIAL, 7R	STAINLESS STEEL/POLYPHENYLSULFONE	GREY 7C
801-05-333	EMPOWR, FIN BASEPLATE TRIAL, 8R MINUS	STAINLESS STEEL/POLYPHENYLSULFONE	WINDY BLUE 7459C
801-05-334	EMPOWR, FIN BASEPLATE TRIAL, 8R	STAINLESS STEEL/POLYPHENYLSULFONE	WINDY BLUE 7459C
801-05-335	EMPOWR, FIN BASEPLATE TRIAL, 9R MINUS	STAINLESS STEEL/POLYPHENYLSULFONE	BLACK 7547C
801-05-336	EMPOWR, FIN BASEPLATE TRIAL, 9R	STAINLESS STEEL/POLYPHENYLSULFONE	BLACK 7547C
801-05-337	EMPOWR, FIN BASEPLATE TRIAL, 10R MINUS	STAINLESS STEEL/POLYPHENYLSULFONE	AQUA 326C

PART NO.	DESCRIPTION	MATERIAL(S)	COLORANT
801-05-338	EMPOWR, FIN BASEPLATE TRIAL, 10R	STAINLESS STEEL/POLYPHENYLSULFONE	AQUA 326C
801-05-339	EMPOWR, FIN BASEPLATE TRIAL, 11R MINUS	STAINLESS STEEL/POLYPHENYLSULFONE	BONE 7527C
801-05-340	EMPOWR, FIN BASEPLATE TRIAL, 11R	STAINLESS STEEL/POLYPHENYLSULFONE	BONE 7527C
801-05-341	EMPOWR, FIN BASEPLATE TRIAL, 11L PLUS	STAINLESS STEEL/POLYPHENYLSULFONE	BONE 7527C
801-05-342	EMPOWR, FIN BASEPLATE TRIAL, 11R PLUS	STAINLESS STEEL/POLYPHENYLSULFONE	BONE 7527C
801-05-401	EMPOWR 3D, INSERT TRIAL, 2L, 10MM	POLYPHENYLSULFONE	LIME GREEN 375C
801-05-402	EMPOWR 3D, INSERT TRIAL, 2L, 12MM	POLYPHENYLSULFONE	LIME GREEN 375C
801-05-403	EMPOWR 3D, INSERT TRIAL, 2L, 14MM	POLYPHENYLSULFONE	LIME GREEN 375C
801-05-404	EMPOWR 3D, INSERT TRIAL, 3L, 10MM	POLYPHENYLSULFONE	RUST 174C
801-05-405	EMPOWR 3D, INSERT TRIAL, 3L, 12MM	POLYPHENYLSULFONE	RUST 174C
801-05-406	EMPOWR 3D, INSERT TRIAL, 3L, 14MM	POLYPHENYLSULFONE	RUST 174C
801-05-407	EMPOWR 3D, INSERT TRIAL, 4L, 10MM	POLYPHENYLSULFONE	YELLOW 101C
801-05-408	EMPOWR 3D, INSERT TRIAL, 4L, 12MM	POLYPHENYLSULFONE	YELLOW 101C
801-05-409	EMPOWR 3D, INSERT TRIAL, 4L, 14MM	POLYPHENYLSULFONE	YELLOW 101C
801-05-410	EMPOWR 3D, INSERT TRIAL, 5L, 10MM	POLYPHENYLSULFONE	NEON ORANGE 1505C
801-05-411	EMPOWR 3D, INSERT TRIAL, 5L, 12MM	POLYPHENYLSULFONE	NEON ORANGE 1505C
801-05-412	EMPOWR 3D, INSERT TRIAL, 5L, 14MM	POLYPHENYLSULFONE	NEON ORANGE 1505C
801-05-413	EMPOWR 3D, INSERT TRIAL, 6L, 10MM	POLYPHENYLSULFONE	VERDE 356C
801-05-414	EMPOWR 3D, INSERT TRIAL, 6L, 12MM	POLYPHENYLSULFONE	VERDE 356C
801-05-415	EMPOWR 3D, INSERT TRIAL, 6L, 14MM	POLYPHENYLSULFONE	VERDE 356C
801-05-416	EMPOWR 3D, INSERT TRIAL, 7L, 10MM	POLYPHENYLSULFONE	GREY 7C
801-05-417	EMPOWR 3D, INSERT TRIAL, 7L, 12MM	POLYPHENYLSULFONE	GREY 7C
801-05-418	EMPOWR 3D, INSERT TRIAL, 7L, 14MM	POLYPHENYLSULFONE	GREY 7C
801-05-419	EMPOWR 3D, INSERT TRIAL, 8L, 10MM	POLYPHENYLSULFONE	WINDY BLUE 7459C
801-05-420	EMPOWR 3D, INSERT TRIAL, 8L, 12MM	POLYPHENYLSULFONE	WINDY BLUE 7459C
801-05-421	EMPOWR 3D, INSERT TRIAL, 8L, 14MM	POLYPHENYLSULFONE	WINDY BLUE 7459C
801-05-422	EMPOWR 3D, INSERT TRIAL, 9L, 10MM	POLYPHENYLSULFONE	BLACK 7547C
801-05-423	EMPOWR 3D, INSERT TRIAL, 9L, 12MM	POLYPHENYLSULFONE	BLACK 7547C
801-05-424	EMPOWR 3D, INSERT TRIAL, 9L, 14MM	POLYPHENYLSULFONE	BLACK 7547C
801-05-425	EMPOWR 3D, INSERT TRIAL, 10L, 10MM	POLYPHENYLSULFONE	AQUA 326C
801-05-426	EMPOWR 3D, INSERT TRIAL, 10L, 12MM	POLYPHENYLSULFONE	AQUA 326C
801-05-427	EMPOWR 3D, INSERT TRIAL, 10L, 14MM	POLYPHENYLSULFONE	AQUA 326C
801-05-428	EMPOWR 3D, INSERT TRIAL, 11L, 10MM	POLYPHENYLSULFONE	BONE 7527C
801-05-429	EMPOWR 3D, INSERT TRIAL, 11L, 12MM	POLYPHENYLSULFONE	BONE 7527C
801-05-430	EMPOWR 3D, INSERT TRIAL, 11L, 14MM	POLYPHENYLSULFONE	BONE 7527C
801-05-431	EMPOWR 3D, INSERT TRIAL, 2R, 10MM	POLYPHENYLSULFONE	LIME GREEN 375C
801-05-432	EMPOWR 3D, INSERT TRIAL, 2R, 12MM	POLYPHENYLSULFONE	LIME GREEN 375C
801-05-433	EMPOWR 3D, INSERT TRIAL, 2R, 14MM	POLYPHENYLSULFONE	LIME GREEN 375C
801-05-434	EMPOWR 3D, INSERT TRIAL, 3R, 10MM	POLYPHENYLSULFONE	RUST 174C
801-05-435	EMPOWR 3D, INSERT TRIAL, 3R, 12MM	POLYPHENYLSULFONE	RUST 174C
801-05-436	EMPOWR 3D, INSERT TRIAL, 3R, 14MM	POLYPHENYLSULFONE	RUST 174C

› Instrument Material list

PART NO.	DESCRIPTION	MATERIAL(S)	COLORANT
801-05-437	EMPOWR 3D, INSERT TRIAL, 4R, 10MM	POLYPHENYLSULFONE	YELLOW 101C
801-05-438	EMPOWR 3D, INSERT TRIAL, 4R, 12MM	POLYPHENYLSULFONE	YELLOW 101C
801-05-439	EMPOWR 3D, INSERT TRIAL, 4R, 14MM	POLYPHENYLSULFONE	YELLOW 101C
801-05-440	EMPOWR 3D, INSERT TRIAL, 5R, 10MM	POLYPHENYLSULFONE	NEON ORANGE 1505C
801-05-441	EMPOWR 3D, INSERT TRIAL, 5R, 12MM	POLYPHENYLSULFONE	NEON ORANGE 1505C
801-05-442	EMPOWR 3D, INSERT TRIAL, 5R, 14MM	POLYPHENYLSULFONE	NEON ORANGE 1505C
801-05-443	EMPOWR 3D, INSERT TRIAL, 6R, 10MM	POLYPHENYLSULFONE	VERDE 356C
801-05-444	EMPOWR 3D, INSERT TRIAL, 6R, 12MM	POLYPHENYLSULFONE	VERDE 356C
801-05-445	EMPOWR 3D, INSERT TRIAL, 6R, 14MM	POLYPHENYLSULFONE	VERDE 356C
801-05-446	EMPOWR 3D, INSERT TRIAL, 7R, 10MM	POLYPHENYLSULFONE	GREY 7C
801-05-447	EMPOWR 3D, INSERT TRIAL, 7R, 12MM	POLYPHENYLSULFONE	GREY 7C
801-05-448	EMPOWR 3D, INSERT TRIAL, 7R, 14MM	POLYPHENYLSULFONE	GREY 7C
801-05-449	EMPOWR 3D, INSERT TRIAL, 8R, 10MM	POLYPHENYLSULFONE	WINDY BLUE 7459C
801-05-450	EMPOWR 3D, INSERT TRIAL, 8R, 12MM	POLYPHENYLSULFONE	WINDY BLUE 7459C
801-05-451	EMPOWR 3D, INSERT TRIAL, 8R, 14MM	POLYPHENYLSULFONE	WINDY BLUE 7459C
801-05-452	EMPOWR 3D, INSERT TRIAL, 9R, 10MM	POLYPHENYLSULFONE	BLACK 7547C
801-05-453	EMPOWR 3D, INSERT TRIAL, 9R, 12MM	POLYPHENYLSULFONE	BLACK 7547C
801-05-454	EMPOWR 3D, INSERT TRIAL, 9R, 14MM	POLYPHENYLSULFONE	BLACK 7547C
801-05-455	EMPOWR 3D, INSERT TRIAL, 10R, 10MM	POLYPHENYLSULFONE	AQUA 326C
801-05-456	EMPOWR 3D, INSERT TRIAL, 10R, 12MM	POLYPHENYLSULFONE	AQUA 326C
801-05-457	EMPOWR 3D, INSERT TRIAL, 10R, 14MM	POLYPHENYLSULFONE	AQUA 326C
801-05-458	EMPOWR 3D, INSERT TRIAL, 11R, 10MM	POLYPHENYLSULFONE	BONE 7527C
801-05-459	EMPOWR 3D, INSERT TRIAL, 11R, 12MM	POLYPHENYLSULFONE	BONE 7527C
801-05-460	EMPOWR 3D, INSERT TRIAL, 11R, 14MM	POLYPHENYLSULFONE	BONE 7527C
801-05-461	EMPOWR, INSERT SPACER TRIAL, SZ 2, 16MM	POLYPHENYLSULFONE	LIME GREEN 375C
801-05-462	EMPOWR, INSERT SPACER TRIAL, SZ 2, 19MM	POLYPHENYLSULFONE	LIME GREEN 375C
801-05-463	EMPOWR, INSERT SPACER TRIAL, SZ 3, 16MM	POLYPHENYLSULFONE	RUST 174C
801-05-464	EMPOWR, INSERT SPACER TRIAL, SZ 3, 19MM	POLYPHENYLSULFONE	RUST 174C
801-05-465	EMPOWR, INSERT SPACER TRIAL, SZ 4, 16MM	POLYPHENYLSULFONE	YELLOW 101C
801-05-466	EMPOWR, INSERT SPACER TRIAL, SZ 4, 19MM	POLYPHENYLSULFONE	YELLOW 101C
801-05-467	EMPOWR, INSERT SPACER TRIAL, SZ 5, 16MM	POLYPHENYLSULFONE	NEON ORANGE 1505C
801-05-468	EMPOWR, INSERT SPACER TRIAL, SZ 5, 19MM	POLYPHENYLSULFONE	NEON ORANGE 1505C
801-05-469	EMPOWR, INSERT SPACER TRIAL, SZ 6, 16MM	POLYPHENYLSULFONE	VERDE 356C
801-05-470	EMPOWR, INSERT SPACER TRIAL, SZ 6, 19MM	POLYPHENYLSULFONE	VERDE 356C
801-05-471	EMPOWR, INSERT SPACER TRIAL, SZ 7, 16MM	POLYPHENYLSULFONE	GREY 7C
801-05-472	EMPOWR, INSERT SPACER TRIAL, SZ 7, 19MM	POLYPHENYLSULFONE	GREY 7C
801-05-473	EMPOWR, INSERT SPACER TRIAL, SZ 8, 16MM	POLYPHENYLSULFONE	WINDY BLUE 7459C
801-05-474	EMPOWR, INSERT SPACER TRIAL, SZ 8, 19MM	POLYPHENYLSULFONE	WINDY BLUE 7459C
801-05-475	EMPOWR, INSERT SPACER TRIAL, SZ 9, 16MM	POLYPHENYLSULFONE	BLACK 7547C
801-05-476	EMPOWR, INSERT SPACER TRIAL, SZ 9, 19MM	POLYPHENYLSULFONE	BLACK 7547C

PART NO.	DESCRIPTION	MATERIAL(S)	COLORANT
801-05-477	EMPOWR, INSERT SPACER TRIAL, SZ 10, 16MM	POLYPHENYLSULFONE	AQUA 326C
801-05-478	EMPOWR, INSERT SPACER TRIAL, SZ 10, 19MM	POLYPHENYLSULFONE	AQUA 326C
801-05-479	EMPOWR, INSERT SPACER TRIAL, SZ 11, 16MM	POLYPHENYLSULFONE	BONE 7527C
801-05-480	EMPOWR, INSERT SPACER TRIAL, SZ 11, 19MM	POLYPHENYLSULFONE	BONE 7527C
801-05-481	EMPOWR 3D, ART SURFACE SPACER, SZ 2L	POLYPHENYLSULFONE	LIME GREEN 375C
801-05-482	EMPOWR 3D, ART SURFACE SPACER, SZ 3L	POLYPHENYLSULFONE	RUST 174C
801-05-483	EMPOWR 3D, ART SURFACE SPACER, SZ 4L	POLYPHENYLSULFONE	YELLOW 101C
801-05-484	EMPOWR 3D, ART SURFACE SPACER, SZ 5L	POLYPHENYLSULFONE	NEON ORANGE 1505C
801-05-485	EMPOWR 3D, ART SURFACE SPACER, SZ 6L	POLYPHENYLSULFONE	VERDE 356C
801-05-486	EMPOWR 3D, ART SURFACE SPACER, SZ 7L	POLYPHENYLSULFONE	GREY 7C
801-05-487	EMPOWR 3D, ART SURFACE SPACER, SZ 8L	POLYPHENYLSULFONE	WINDY BLUE 7459C
801-05-488	EMPOWR 3D, ART SURFACE SPACER, SZ 9L	POLYPHENYLSULFONE	BLACK 7547C
801-05-489	EMPOWR 3D, ART SURFACE SPACER, SZ 10L	POLYPHENYLSULFONE	AQUA 326C
801-05-490	EMPOWR 3D, ART SURFACE SPACER, SZ 11L	POLYPHENYLSULFONE	BONE 7527C
801-05-491	EMPOWR 3D, ART SURFACE SPACER, SZ 2R	POLYPHENYLSULFONE	LIME GREEN 375C
801-05-492	EMPOWR 3D, ART SURFACE SPACER, SZ 3R	POLYPHENYLSULFONE	RUST 174C
801-05-493	EMPOWR 3D, ART SURFACE SPACER, SZ 4R	POLYPHENYLSULFONE	YELLOW 101C
801-05-494	EMPOWR 3D, ART SURFACE SPACER, SZ 5R	POLYPHENYLSULFONE	NEON ORANGE 1505C
801-05-495	EMPOWR 3D, ART SURFACE SPACER, SZ 6R	POLYPHENYLSULFONE	VERDE 356C
801-05-496	EMPOWR 3D, ART SURFACE SPACER, SZ 7R	POLYPHENYLSULFONE	GREY 7C
801-05-497	EMPOWR 3D, ART SURFACE SPACER, SZ 8R	POLYPHENYLSULFONE	WINDY BLUE 7459C
801-05-498	EMPOWR 3D, ART SURFACE SPACER, SZ 9R	POLYPHENYLSULFONE	BLACK 7547C
801-05-499	EMPOWR 3D, ART SURFACE SPACER, SZ 10R	POLYPHENYLSULFONE	AQUA 326C
801-05-500	EMPOWR 3D, ART SURFACE SPACER, SZ 11R	POLYPHENYLSULFONE	BONE 7527C
802-05-003	EMPOWR, PATELLA DRILL GUIDE, 26/29/32MM	STAINLESS STEEL	NONE
802-05-004	EMPOWR, PATELLA DRILL GUIDE, 35/38MM	STAINLESS STEEL	NONE
802-05-006	EMPOWR, PATELLA SEATER	STAINLESS STEEL	NONE
802-01-094	TRIAL, DOMED PATELLA 26X8MM	ACETAL COPOLYMER	YELLOW 130C
802-01-095	TRIAL, DOMED PATELLA 29X8MM	ACETAL COPOLYMER	RUST 1675C
802-01-096	TRIAL, DOMED PATELLA 32X8MM	ACETAL COPOLYMER	GREEN 3288C
802-01-097	TRIAL, DOMED PATELLA 35X9MM	ACETAL COPOLYMER	BLUE 293C
802-01-098	TRIAL, DOMED PATELLA 38X9MM	ACETAL COPOLYMER	BLACK 3C 2X
800-05-035	LOCKING FEMORAL IMPACTOR	STAINLESS STEEL / POLYPROPYLENE	BKVO10
800-05-036	LOCKING FEMORAL IMPACTOR REPLACEMENT HEAD	POLYPROPYLENE	BKVO10
800-05-102	EMPOWR, GAP BALANCER, LAMINA SPREADER	STAINLESS STEEL	NONE
801-05-004	EMPOWR, TIBIAL TRANSITION MODULE	STAINLESS STEEL	NONE
801-05-113	DJO EMPOWR KNEE, EM PROXIMAL BODY 2	STAINLESS STEEL	NONE
801-05-011	EMPOWR, TIBIAL IM GUIDE BASE	STAINLESS STEEL	NONE
801-05-012	EMPOWR, TIBIA IM 0/3/6 DEG GUIDE	STAINLESS STEEL	NONE
800-05-102	DJO EMPOWR TM, GAP BALANCER, LAMINA SPREADER	STAINLESS STEEL	NONE

➤ Reference Guide

CEMENT AND CEMENT ACCESSORIES



Cobalt® HV Bone Cement

PART NO.	DESCRIPTION	SIZE
402282	Cobalt HV Bone Cement	40g



Cobalt® MV Bone Cement

PART NO.	DESCRIPTION	SIZE
402438	Cobalt MV Bone Cement	40g



Optivac® Vacuum Mixing System

PART NO.	DESCRIPTION
417000	Total Hip kit, 40g Single Mix
417200	Total Hip kit, 80g Double Mix
417300	Total Hip kit, 120g Triple Mix



Optitwist® Vacuum Mixing Bowl

PART NO.	DESCRIPTION
419100	Max Capacity 120g (3 units) High Viscosity (Pk of 20)



Optigun® Cement Gun

PART NO.	DESCRIPTION
419300	Optigun® Cement Gun



EMPOWR Knee System™
NATURAL MOTION TECHNOLOGY



DJO Surgical | A DJO Global Company
T 800.456.8696 **D** 512.832.9500 **F** 512.834.6300
9800 Metric Blvd. | Austin, TX 78758 | U.S.A.
djoglobal.com/djosurgical