

Firmware Installation Guide

For Proto-Plastik Marlin-based controllers

About this guide

You may view this guide directly from the Proto-Plastik Github Repo (<https://github.com/Proto-Plastik/Firmware/blob/master/Documentation/Firmware%20Installation%20Instructions.pdf>). However, note that your browser will not allow PDF links to be displayed. To enable links, click the **Download** button in the repository.

This firmware is based on a release of Marlin. Typically, this release will be behind the current Marlin release. You are free to download the latest Marlin firmware from the Marlin repo, but be warned! Unless you know what you're doing, you could cause a lot of problems with your printer. The firmware on this site has been configured specifically for Proto-Plastik 3D printers. We will evaluate new release candidates from Marlin and post updates from time to time on the Proto-Plastik repo.

If you find any discrepancies with this guide, please let us know.

Before you start

If you are using a RMPS 1.4 (Arduino + RAMPS shield) it should be fully assembled. You do not need to power the board but you do need the USB cable that came with the board. DO NOT plug in the cable at this time.

You will need the following applications installed:

- The **Arduino IDE** (Windows). You will need this to compile and upload the Marlin firmware onto the RAMPS 1.4 board or the MKS Base 1.5 board.
 - Download and install the latest IDE here <https://www.arduino.cc/en/Main/Software>
 - This will also install the USB driver
- **Repetier Host** for printer controller software.
 - <https://www.repetier.com/>
 - Note: you may also use other printer controller software such as Matter Control. However, all instructions here will use Repetier. Other software should provide the same functionality.
 - The overview in this guide is not intended to be a comprehensive user guide for Repetier or Slic3r. Please visit the Repetier site or explore the various online 3D communities to learn more about the software.

Download the Marlin firmware for your printer from the Proto-Plastik github repository.

- <https://github.com/Proto-Plastik/Firmware>
- Click the **Clone or download** button at the upper right of the repository. Select Download ZIP

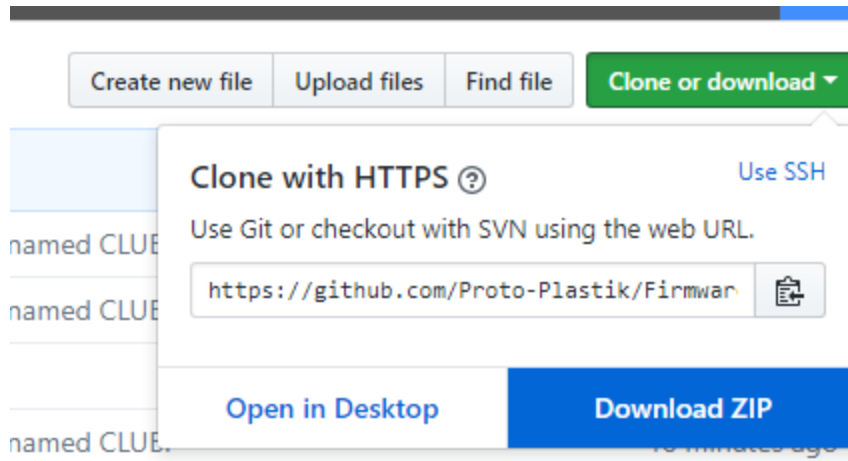

- In your download location, you will see a .zip file called **Firmware-master.zip**. That .zip file will contain firmware for all Proto-Plastik 3D printers. Unzip the firmware matching your printer.

Firmware Installation

- Plug the controller into the computer with the supplied USB cable. **Do not plug in the power cable at this time.** The controller should be recognized by your computer and will show up as a com port (e.g. COM4). The light on the controller will blink slowly.
- Open up the Arduino IDE
- Navigate to the folder where your firmware is located
- Select the file with the .ino extension

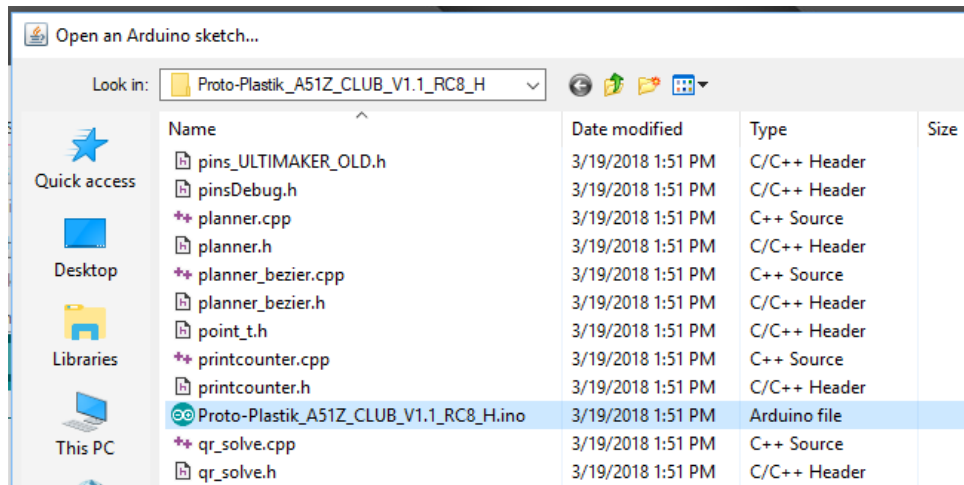

Configure Arduino IDE

If the IDE has never been installed before, you will need to add one additional library called **U8glib**.

To add this library:

- In the IDE, go to the Sketch->Include Library->Manage Libraries



- In the dialog search bar, type in **U8glib**. The library will show up in the list (it is shown as installed here). Click anywhere in the box and an Install button will appear. Install the library.

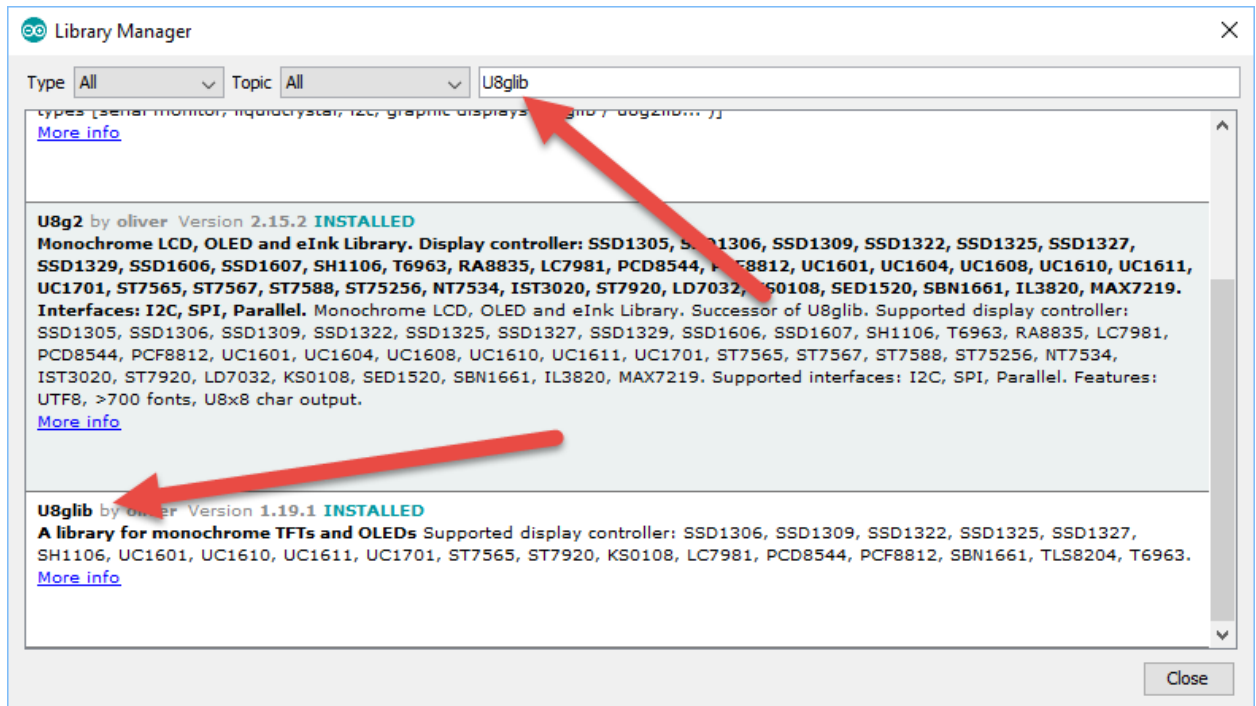

- Next, ensure '...Mega 2560' is selected and that the Processor is also ATmega2560

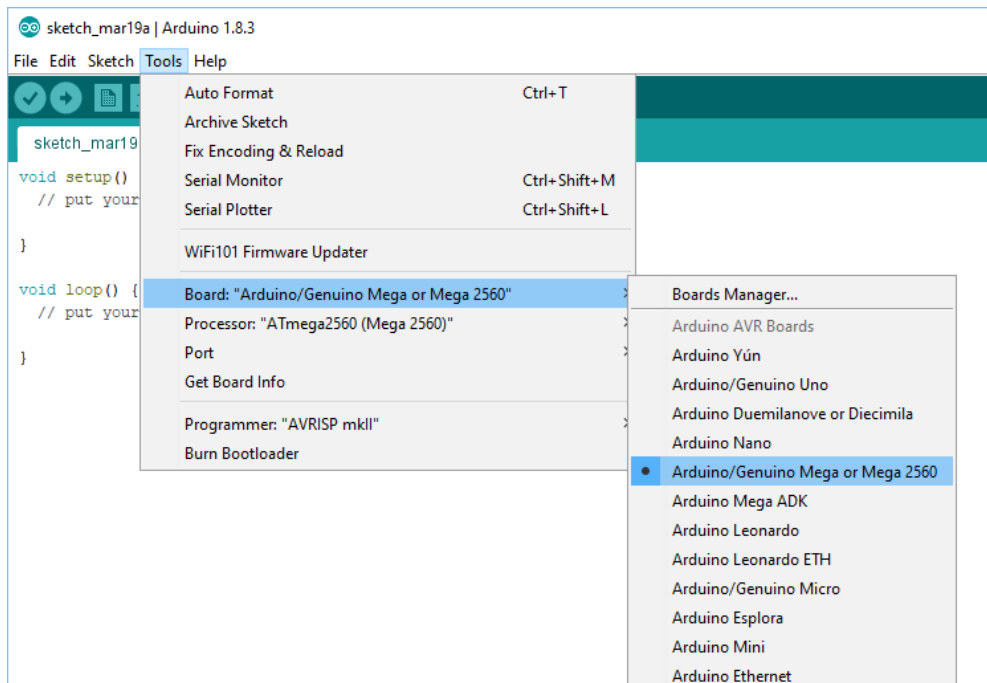

Compile and Upload the Sketch

- Select the COM port that was automatically set when you plugged the board in. Note, it is unlikely that it would be COM1.

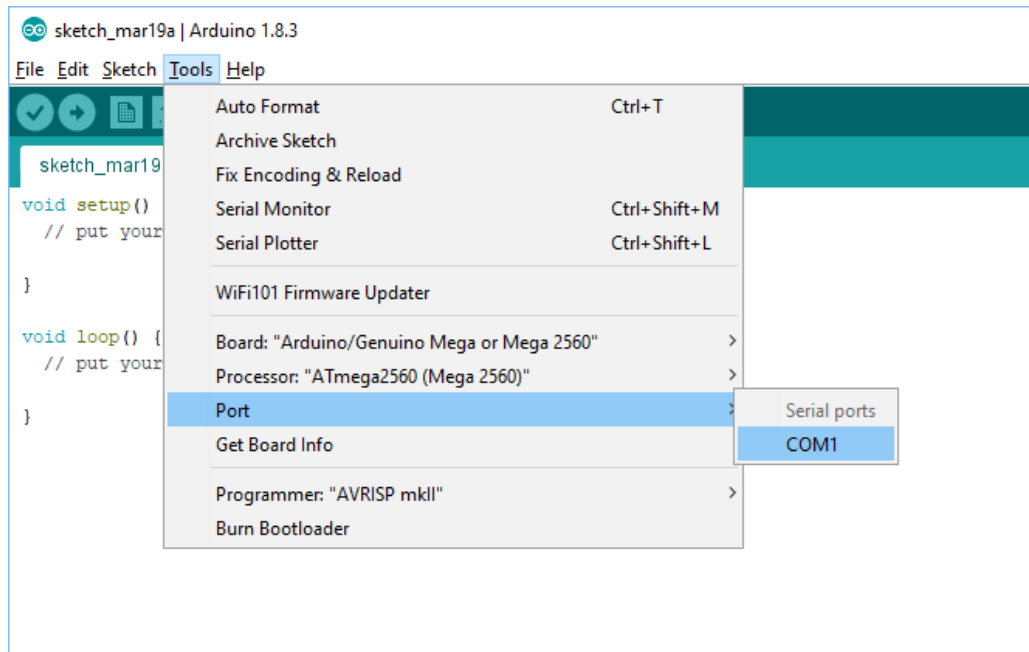

- Select the **Verify** icon to compile the firmware. You will see an indication at the bottom that says **Compiling Sketch**.

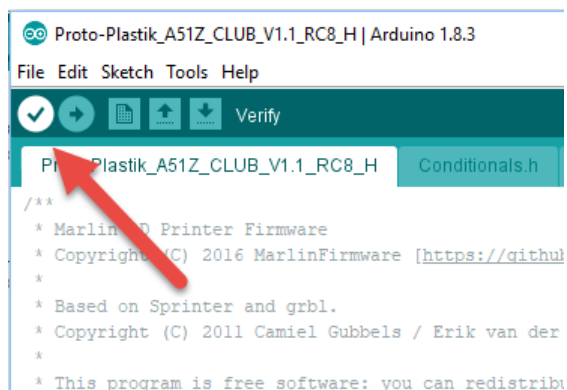

- Once the message 'Done compiling' appears at the bottom, select the **Upload** icon

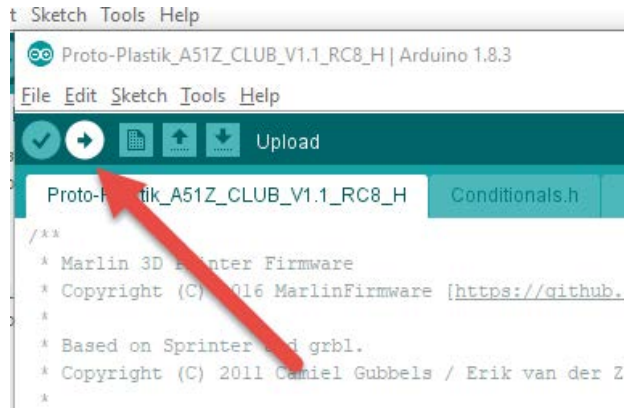

- While uploading, the light on the RAMPS board will blink rapidly until the upload is complete.
- When the upload is complete, the light on the RAMPS board will turn off.

Testing the Firmware

To test the firmware, you need to attach all wires from your printer into the appropriate locations. The diagram below shows a typical setup. Note optional Endstop switches. Connect power as shown below.

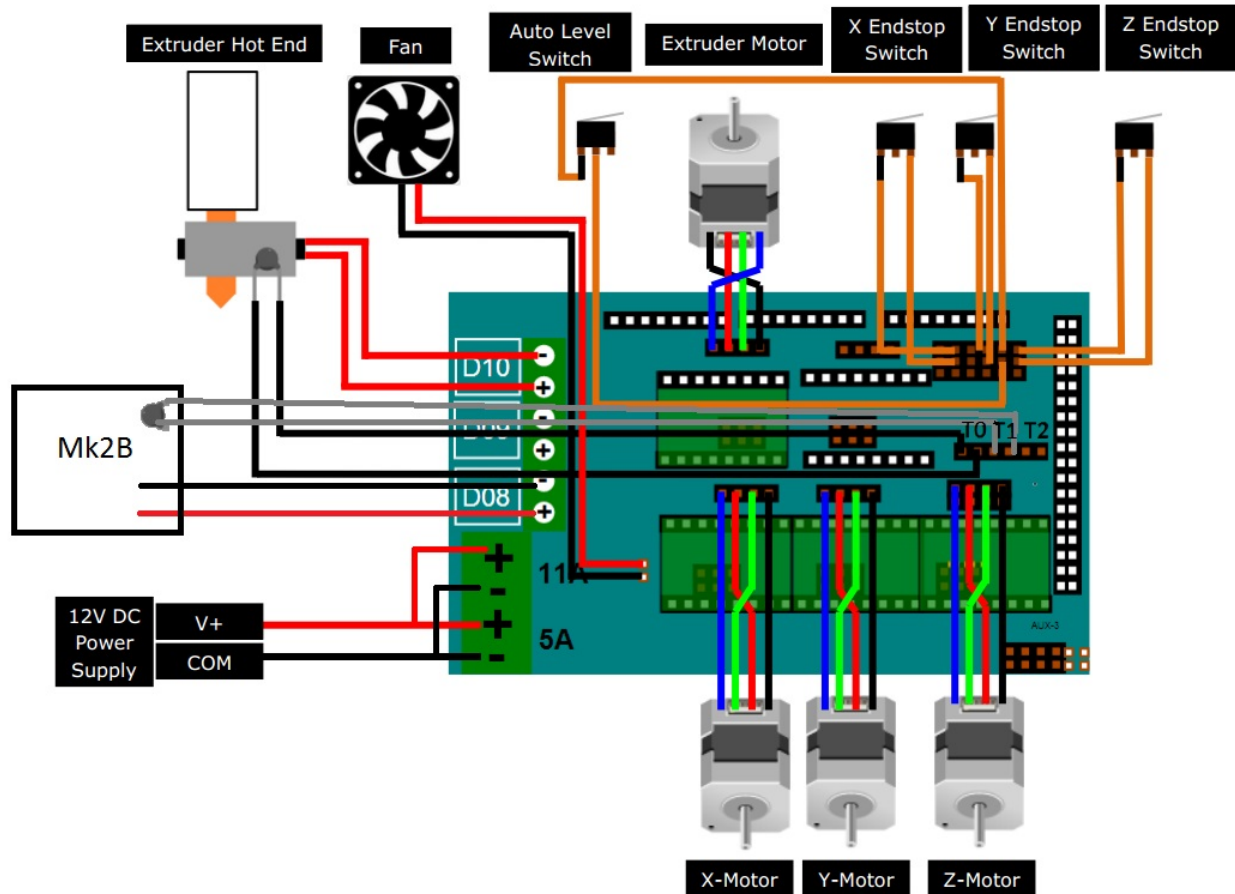

- Connect power. Once power is applied, the fan on the hot end will come on. This is normal.
- Connect USB cable
- Open Repetier Host software

- At the upper righthand side, select the **Printer Settings** icon

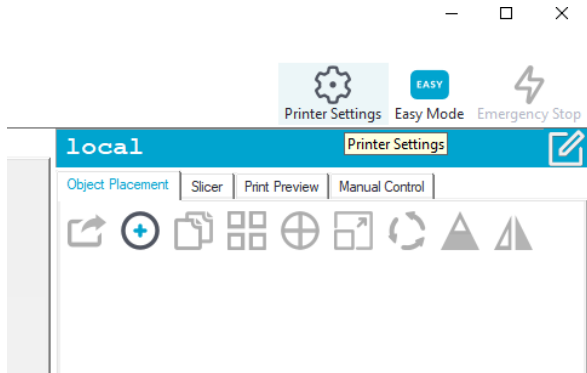

- In the window that appears, select **Serial Connection** then select the COM port that matches the COM port of your printer (typically NOT COM1). Leave the rest at the default. Click **Ok**.

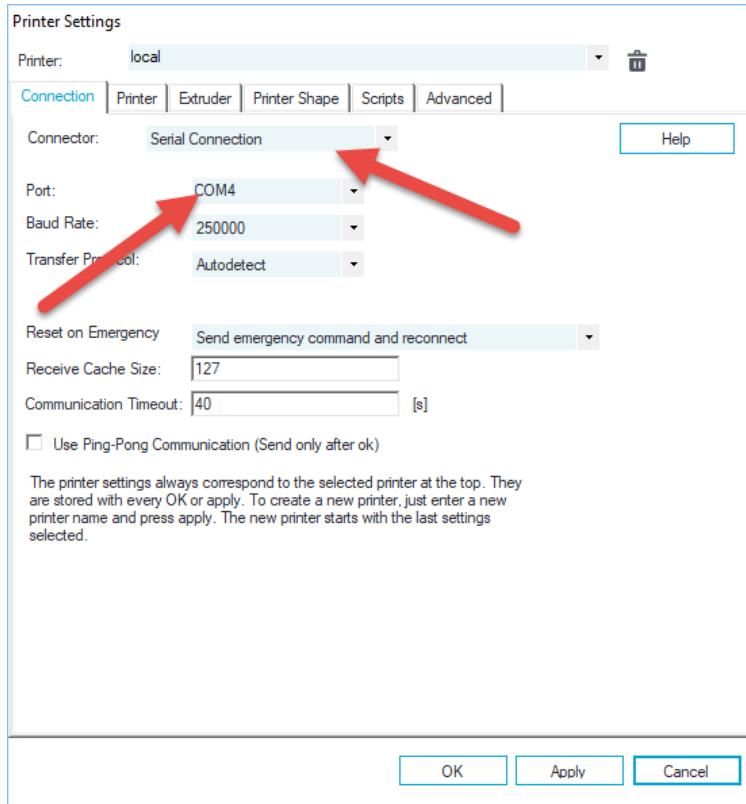

- In the upper left window, select **Connect**

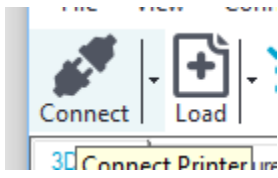

- Once successfully connected, the icon will change

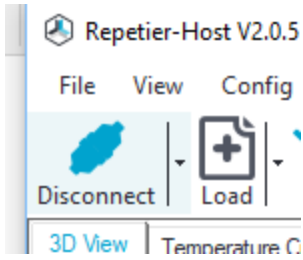

- On the righthand side, select the **Manual Control** tab. Use the Manual Control to move the printer in the X, Y, and Z axes.
IMPORTANT NOTE: DO NOT CLICK ON THE HOME BUTTONS. These only work if you have endstops installed. If you click any home button, the printer will try to home but will not find any endstops. This will cause the printer to continue to attempt movement even if it has reached the max or min travel. If your printer does have endstops, then it is fine to use the home buttons.

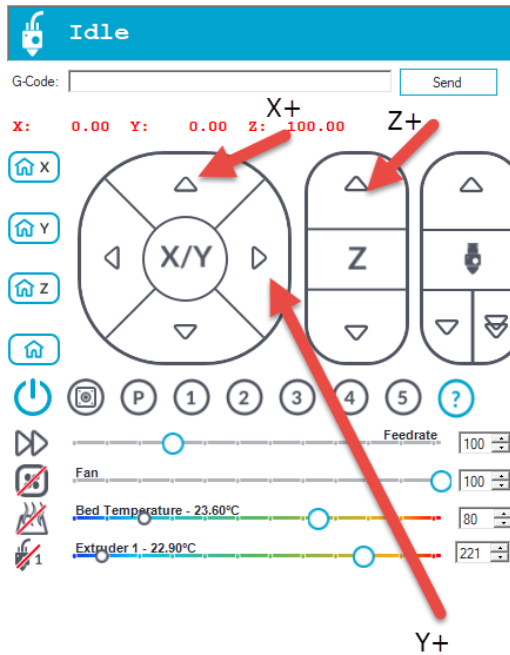

- Start with **SMALL** increments first to verify movement in the correct direction. X+ moves the print carriage to the right, Y+ moves the bed forward toward the front, Z+ moves the print carriage up. If any of the axes go in the wrong direction, turn the connector on the board 180 degrees for that axis.

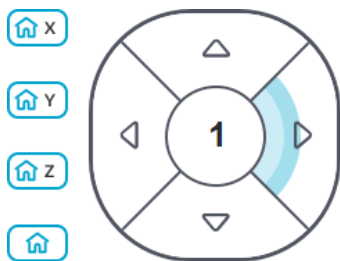

- Test the hot end and heated bed. Note that you should be reading an ambient temperature between 20C and 30C. For both the heated bed and hot end. If you have a reading of zero or a reading well over 30C, you will need to verify connection of the thermistors and make sure there are no broken wires.

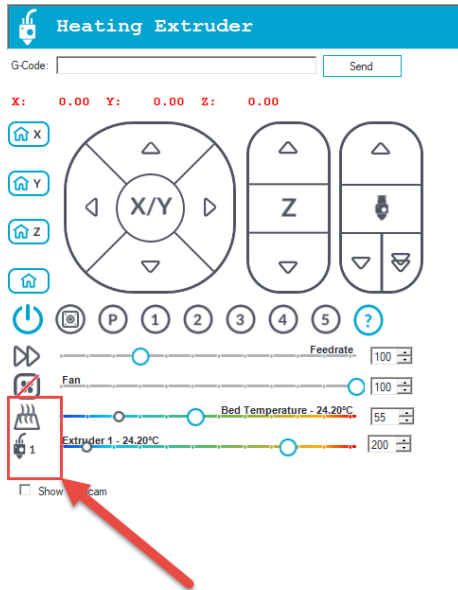

- After a few seconds, you should notice the temperatures on both the hot end and heated bed starting to rise. Also, the fan on the power supply may start up. That's normal. There will also be red LED indicators on the controller board.

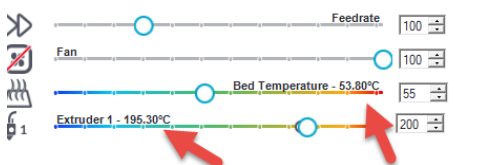

- If all the tests pass, you may shut down the printer. You can do this simply by pulling the power supply's plug from the wall outlet or by clicking the hot end and heated bed icons in Manual Control to turn them off.

Printer Setup Instructions

Slic3r configuration

In order to process 3D STL models, a program has to 'slice' the part into layers that are then converted to the programming language (GCode) the printer understands.

Repetier is able to use 3 different slicers, Cura, Skeinforge, and Slic3r. Slic3r is the default and is the one covered in these instructions.

To set up the slicer

- Make sure the file **A5 Slic3r Config Bundle.ini** has been extracted from the Firmware repository. This is located in the Configuration folder of the Firmware repository downloaded from the GitHub site
- In Repetier, select the **Slicer** tab
- In the Slicer dropdown, select **Slic3r**

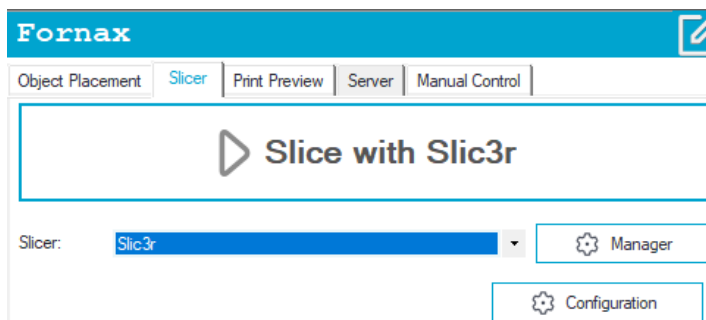

- Select the **Configuration** button
- In the Slic3r window, choose File->Load Config Bundle...

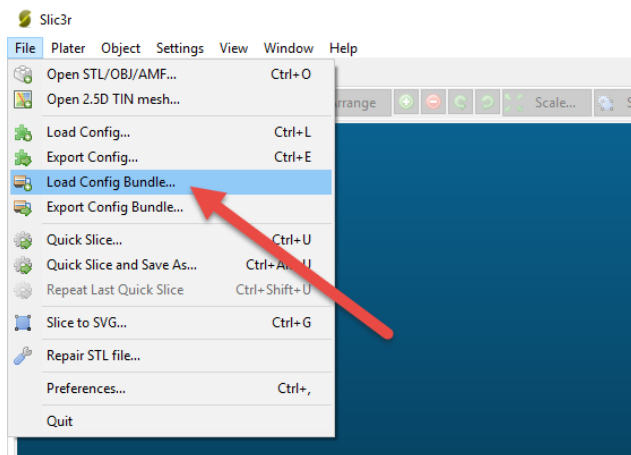

- Choose the **A5 Slic3r Config Bundle.ini** file
- Once that's loaded, your Print Settings, Filament, and Printer settings will be loaded

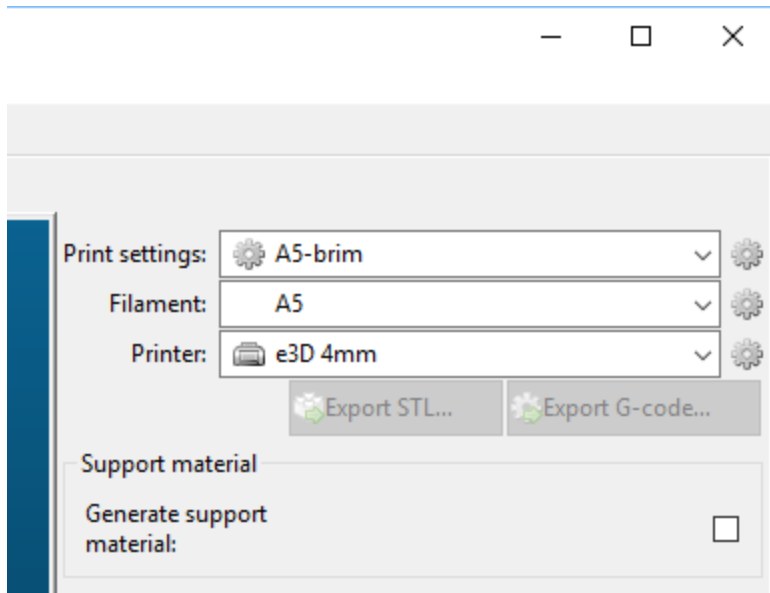

- Exit the Slic3r dialog window

Slicing

These initial settings are in place to get you started. Feel free to experiment with various settings. You can always get back to the various configurations by selecting the **Configuration** button as before. Trial and error (with a lot of help from the web) is a good way to understand all the options available.

To slice your model, first load an STL file into Repetier.

- Go to the **Object Placement** tab.

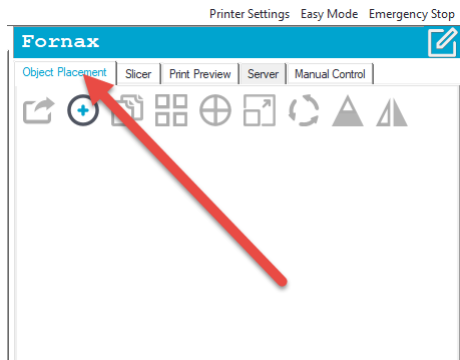

- Select the  icon to load a file
- Repetier will automatically center the part on the bed
- Go to the **Slicer** tab
- **Print Settings, Printer Settings, and Filament Settings** will already be selected. There are two settings for **Print Setting**: A5 and A5-no brim. There are also two for **Filament Settings**: A5 and A5-no part fan. If your printer does not have a part cooling fan, select the latter.
- Select the big **Slice with Slic3r**



- You will get a preview of the part showing layers and patterns needed to print. This part was sliced with **A5** selected under **Print Setting**. Hence, you can see it was sliced with a brim

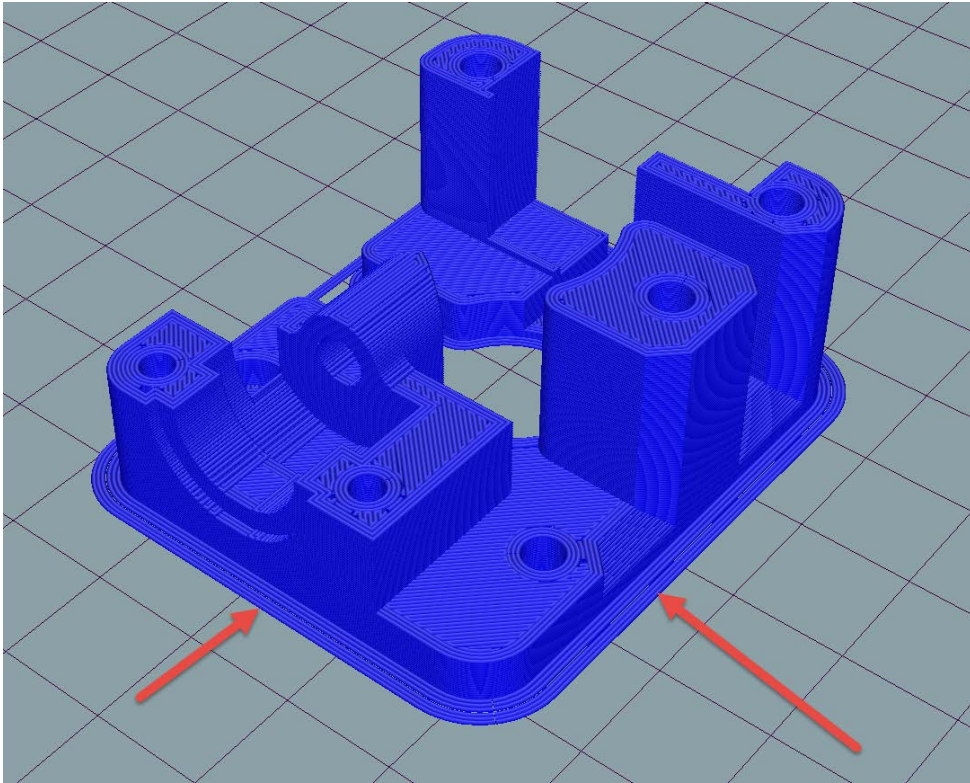

Printer Setup

Printer setup configures the physical parameters of the printer as well as providing scripts to automate certain tasks.

- Select the **Printer Settings** icon at the very top right of the Repetier window

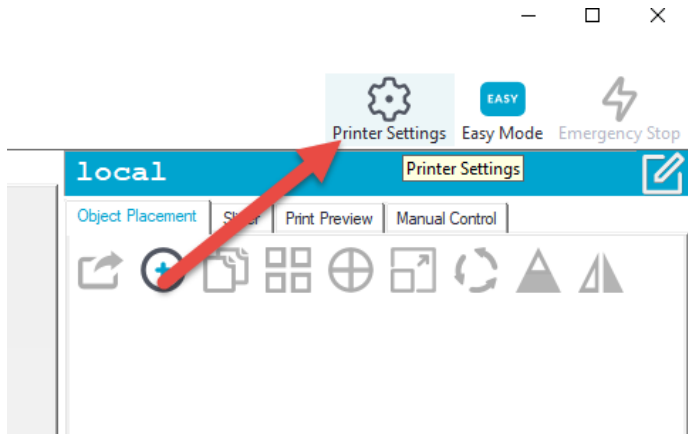

- The **Printer** tab should have values as below

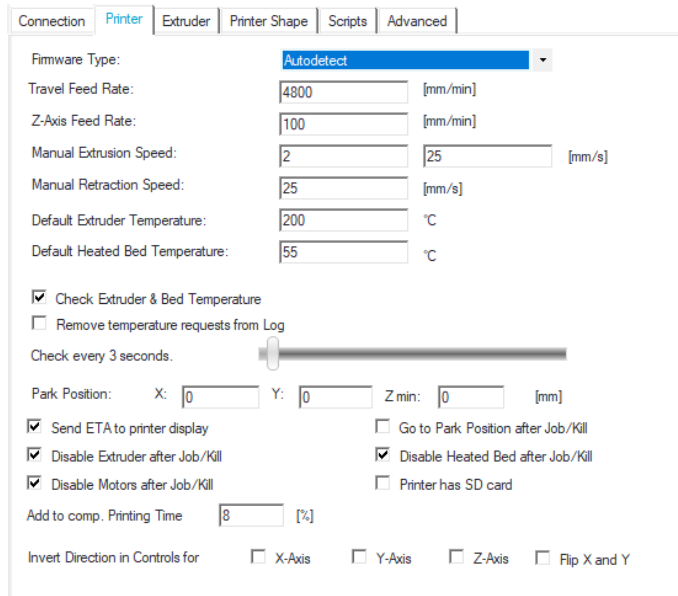
A screenshot of the 'Printer' tab settings in Repetier-Host. The settings are as follows:

Firmware Type:	Autodetect
Travel Feed Rate:	4800 [mm/min]
Z-Axis Feed Rate:	100 [mm/min]
Manual Extrusion Speed:	2 [mm/s]
Manual Retraction Speed:	25 [mm/s]
Default Extruder Temperature:	200 °C
Default Heated Bed Temperature:	55 °C
<input checked="" type="checkbox"/> Check Extruder & Bed Temperature	
<input type="checkbox"/> Remove temperature requests from Log	
Check every 3 seconds.	<input type="range"/>
Park Position: X:	0 [mm]
Y:	0 [mm]
Z min:	0 [mm]
<input checked="" type="checkbox"/> Send ETA to printer display	<input type="checkbox"/> Go to Park Position after Job/Kill
<input checked="" type="checkbox"/> Disable Extruder after Job/Kill	<input checked="" type="checkbox"/> Disable Heated Bed after Job/Kill
<input checked="" type="checkbox"/> Disable Motors after Job/Kill	<input type="checkbox"/> Printer has SD card
Add to comp. Printing Time	8 [%]
Invert Direction in Controls for	<input type="checkbox"/> X-Axis <input type="checkbox"/> Y-Axis <input type="checkbox"/> Z-Axis <input type="checkbox"/> Flip X and Y

- The **Extruder** tab

Connection | Printer | **Extruder** | Printer Shape | Scripts | Advanced

Number of Extruder:

Number of Fans:

Max. Extruder Temperature:

Max. Bed Temperature:

Max. Volume per second [mm³/s]

Printer has a Mixing Extruder (one nozzle for all colors)

Extruder 1

Name:

Diameter: [mm] Temperature Offset: [°C]

Color:

Offset X: Offset Y: [mm]

- The **Printer Shape** tab

Connection | Printer | Extruder | **Printer Shape** | Scripts | Advanced

Printer Type: **Classic Printer**

Home X: Home Y: Home Z:

X Min: X Max: Bed Left:

Y Min: Y Max: Bed Front:

Print Area Width: mm

Print Area Depth: mm

Print Area Height: mm

The min and max values define the possible range of extruder coordinates. These coordinates can be negative and outside the print bed. Bed left/front define the coordinates where the printbed itself starts. By changing the min/max values you can even move the origin in the center of the print bed, if supported by firmware.

The diagram shows a gray rectangle labeled 'E' representing the print area. The width is labeled 'C' and the depth is labeled 'D'. A vertical axis on the left is labeled 'Y Max'.

- The **Scripts** tab

- Scripts are Printer Specific
- Use **Script 1** to automate initialization of the printer before printing
- CLUB (Without heated bed)

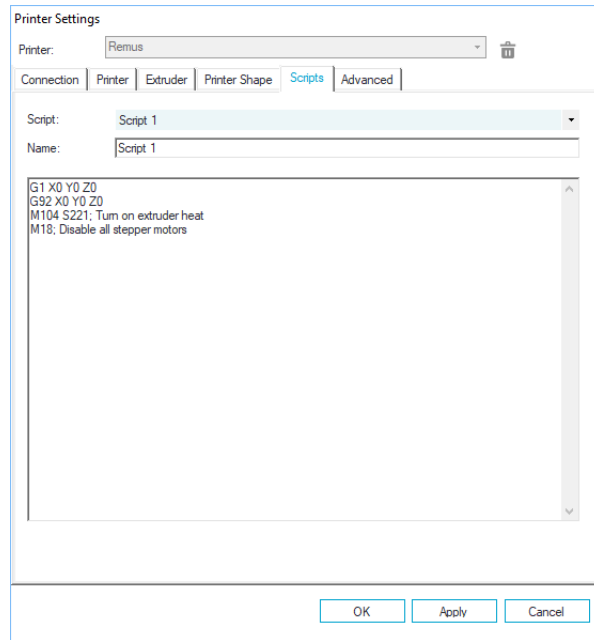

- CLUB (With heated bed)

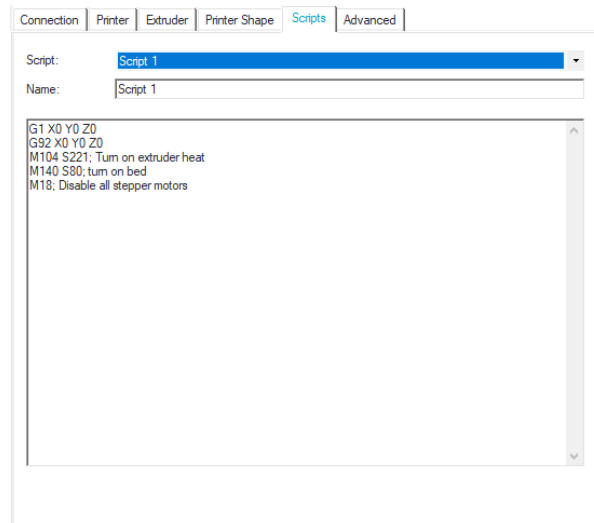

○ MAKER

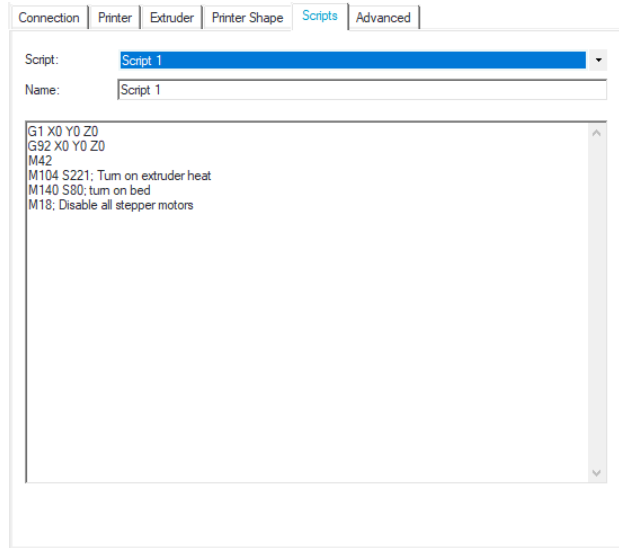

○ PROFESSIONAL

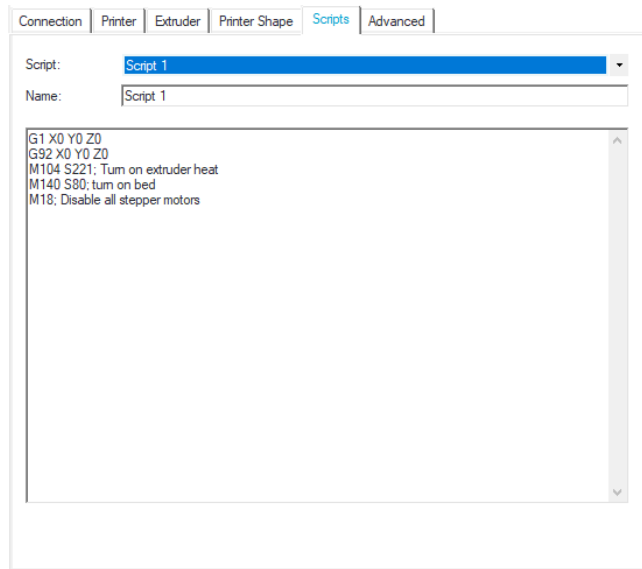

○ ULTIMATE

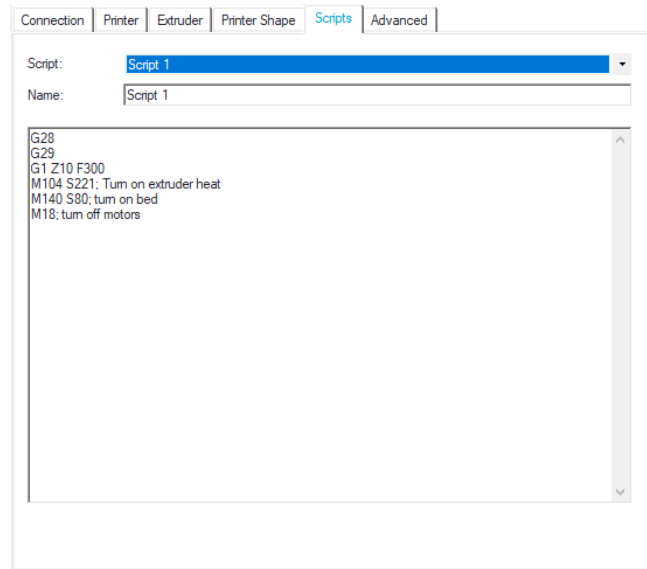

- Once you have set up your script for Script 1, click Ok to save it
- **DO NOT RUN THE SCRIPT AT THIS TIME**

Printing

Before printing, you need to make sure your printer is homed. This can be done either manually or automatically depending on your printer's configuration. Homing and leveling will be covered in a different section.

- To ensure that your printer is ready to print, once homed you should see the values below under the Manual Control tab. Do not try to print if these values are not zero.

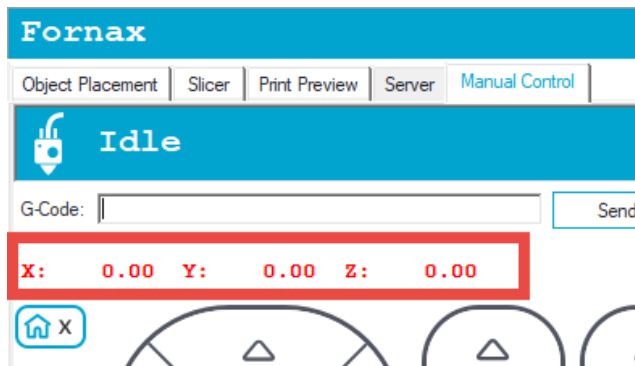

- If the values are not zero **and you have homed the hot end**, you will have to zero them out manually. The best way to ensure these values are zeroed out is to remove both the power and the USB cable from the controller. On the CLUB you remove power by disconnecting the power supply from the wall outlet.

On the MAKER, you turn off the main switch (if using a Smoothieboard) or from the auxiliary 12v switch. For the PROFESSIONAL and ULTIMATE, use the auxiliary 12v switch

- Once homed, you may select **Script 1**

The script can be accessed on the **Manual Control** tab by clicking on 1



This will turn on heaters and other components as well as establish absolute zero in XYZ

- Begin printing by going to the **Print Preview** tab and selecting **Print**

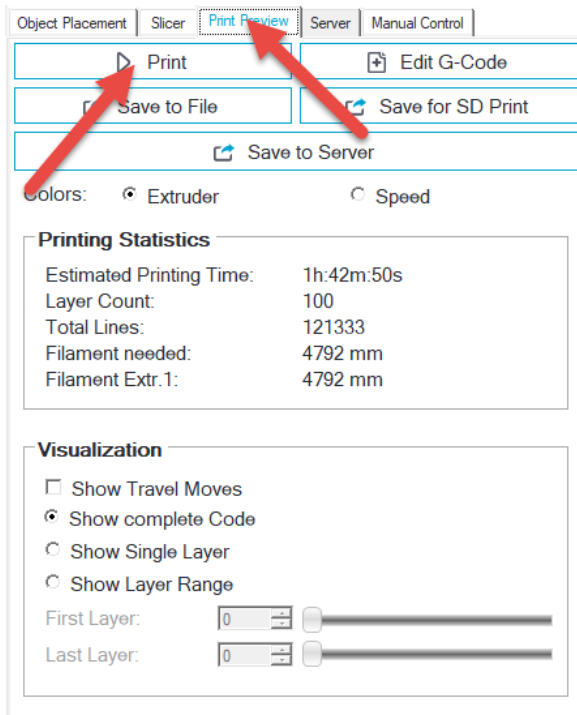

- Once the part is completed, the hot end will move up for clearance and the bed will move out.
- To print again, make sure your parts are removed and ALWAYS run **Script 1** before printing. This will home the hot end.