

Service Bulletin

FEBRUARY 2007

LAUNDRY
ALL "HYDROWAVE" MODELS

HL 01-07

MOTOR-INVERTER DRIVE SYSTEM – 2 FLASH INVERTER BOARD ERROR (MOTOR APPEARS DEAD)

This service bulletin is to notify technicians of a potential cause for a **2 flash error** on the new Motor-Inverter drive system.

The **2 flash error** was intended to represent a slipping belt condition as identified in the mini-manual. Based on field feedback, a **loose hub nut** may also simulate the conditions that the inverter uses to detect a slipping belt condition. Because a slipping belt presents a safety concern for the machine to brake/stop normally, the inverter disables the motor while setting the **2 flash error** code. The motor will not agitate or spin in this condition, so the **motor appears DEAD**.

A **loose hub nut** may be obvious in severe circumstances where the basket has damaged the balance ring, the tub cover, or the tub. In some instances, it is more difficult to detect if the hub nut has not fully backed off. NOTE: The HYDROWAVE drive does not have a mechanical brake like the drive system with transmission. The basket may rotate freely depending on the state of the mode shifter assembly. It may require closer inspection of the hub nut. If the threads of the nut are damaged, the nut will not hold the tub securely. Always **replace the hub nut if any damage** is noticed. Tighten the nut to **110 ft. lbs**.

Procedure for repair:

1. Remove the agitator and agitator coupling
2. Inspect for damaged components (replace as necessary)
3. Tighten the hub nut with a torque wrench or impact gun (current factory torque setting is 110 FT-LBS)

MODELS: 2006 and 2007 models listed subject to change with future production.

57751H0WW	WCRD2050F3WC	WJRE5500G0WW
EWA5600G0WW	WCRE6270G0CC	WJRR4170E6WW
GHDRE527H0WW	WCRE6270G0WW	WJRR4170G0CC
GHDSR316H0WW	WCSR2090DCWW	WJRR4170G0WW
GJRR4170H0WW	WCSR2090G1CC	WJSR4160G0WW
GJSR4160H0WW	WCSR2090G1WW	WLRE4500G0WW
GKSR3140H0WW	WCSR4170DCWW	WLR5000G0WW
GNSR3150H0WW	WCSR4170G0CC	WLSE4000G0WW
GWSE5240H0WW	WCSR4170G0WW	WLSR3000G0WW
S3700G0WW	WDSR2080DCWW	WMCD2050G0WC
VBSR3100G0WW	WHDRR418G0WW	WNRD2050DCWC
VWSR4160G0WW	WHDSR316G0WW	WPRE6100G0WT
WBB4500G0WW	WISR106DGBWW	WPRE8100G0WT
WBSR3140G0WW	WISR309DGBWW	WPRE8320H0WT
WCCB1030F3WC	WISR409DGBWW	WWSE5240G0WW
WCCD2050F3WC		

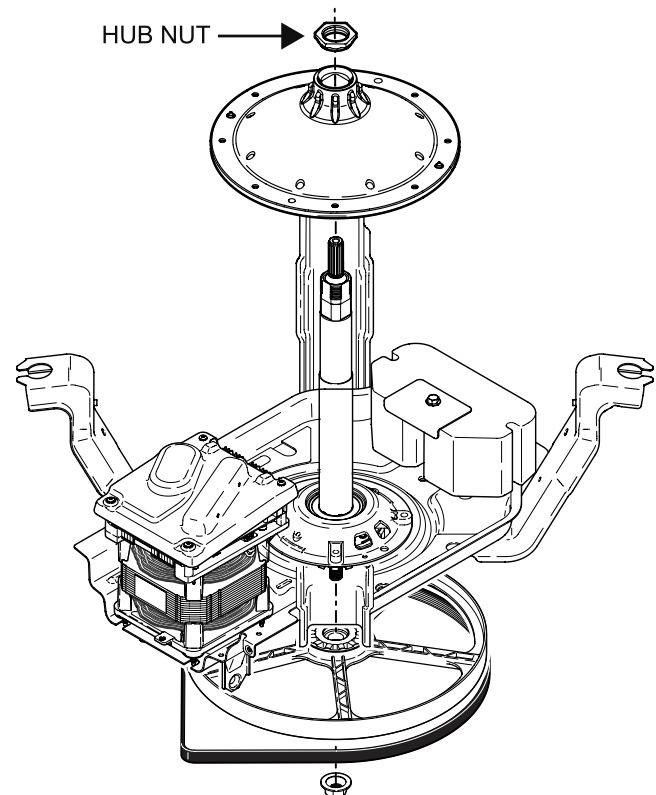

GE Appliances
General Electric Company
Louisville, Kentucky 40225

GE CONFIDENTIAL AND PROPRIETARY INFORMATION–NOT FOR PUBLIC DISCLOSURE

Clearing Motor-Inverter error codes:

1. Disconnect the washer from power and wait approximately 15 seconds (hear a click/capacitor discharge)
2. Reconnect the washer to power and allow the relay to click (approximately 2 seconds).
3. Open and close the lid 5 or more times (in any 12 second period within the first 30 seconds of power up)

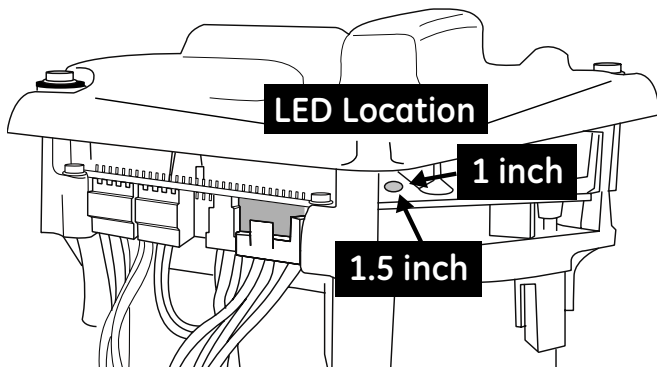

The LED is best viewed from the right front of the motor, 1.5" back and 1" into board.

HydroWave Washer Customer Education

The new drive system design is also creating a high number of Customer Education calls. The calls are primarily in two areas: Washer Performance (not agitating) and Washer Noise. These CE calls are an excellent opportunity to contact the consumer and discuss what operating characteristics and sounds are normal. Making the consumer aware of what is normal may save the service call.

- The consumer doesn't think the washer is agitating because it's too quiet. They don't realize the motor has to sense the load and engage the drive, which takes 20-30 seconds after the tub has filled with water. Have the consumer throw in an article of clothing, let it run for a minute and then open the lid. They should see the article has moved around if the washer is agitating correctly.
- When the consumer hears the mode shifter engage and disengage they hear a "clicking" sound and assume it's broken. This sound is normal and occurs when the washer goes in and out of agitate and spin. The consumer will hear this multiple times throughout the wash cycle.

NUMBER OF FLASHES	DESCRIPTION	ACTION
1 SECOND ON 1 SECOND OFF	NORMAL STANDBY	NORMAL STANDBY
.5 SECOND ON .5 SECOND OFF	NORMAL RUNNING	NORMAL RUNNING
1 FLASH	LONG STOP TIME	REPLACE MOTOR
2 FLASH	SLIPPING BELT	CHECK BELT*
3 FLASH	CORRUPTED SOFTWARE	REPLACE MOTOR
4 FLASH	MODE SHIFT CIRCUIT FAILED	CHECK MODE SHIFTER COIL*
5 FLASH	NOT IMPLEMENTED	REPLACE MOTOR
6 FLASH	LOCKED MOTOR	MAKE SURE SYSTEM IS FREE*
7 FLASH	LID SWITCH DID NOT OPEN	CHECK LIDSWITCH*
8 FLASH	MOTOR OVERHEATED	MAKE SURE SYSTEM IS FREE*
9 FLASH	BRAKE RESISTOR OPEN	REPLACE MOTOR
ON 2, 4, 6, 7 & 8 FLASH ERRORS IF NO SYSTEM FAILURES ARE FOUND, REPLACE MOTOR		