

Grant UK VortexBlue

21, 26 and 36kW Blue Flame Oil Boiler Range

Supplementary User, Installation and Servicing Instructions

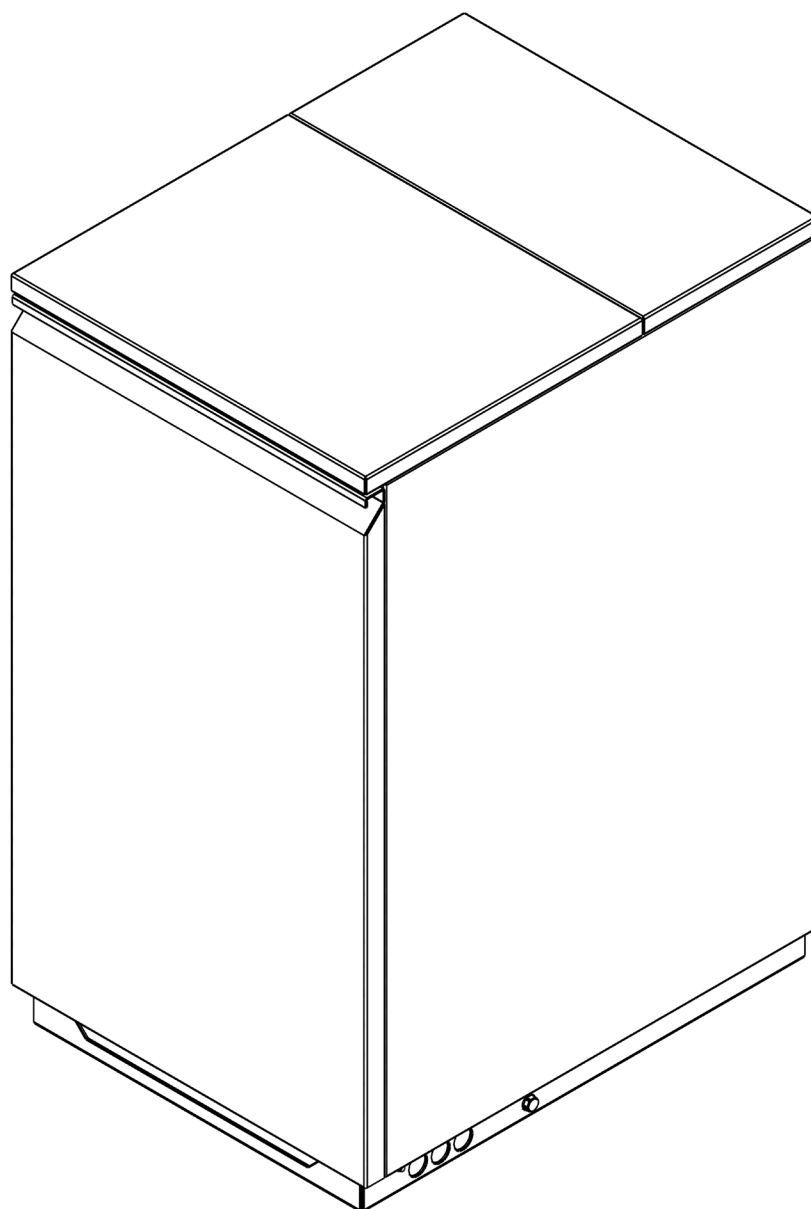



GRANT ENGINEERING (UK) LIMITED

Hopton House, Hopton Industrial Estate, Devizes, Wiltshire, SN10 2EU

Tel: +44 (0)1380 736920 Fax: +44 (0)1380 736991

Email: info@grantuk.com www.grantuk.com

This manual is accurate at the date of printing but will be superseded and should be disregarded if specifications and/or appearances are changed in the interests of continued product improvement. However, no responsibility of any kind for any injury, death, loss, damage or delay however caused resulting from the use of this manual can be accepted by Grant Engineering (UK) Limited, the author or others involved in its publication.

All goods sold are subject to our official Conditions of Sale, a copy of which may be obtained on application.

© Grant Engineering (UK) Limited 2016. No part of this manual may be reproduced by any means without prior written consent.

Contents

1	User Instructions	4	6	Commissioning	22
1.1	VortexBlue Kitchen/Utility, Kitchen/Utility System Boilers and External Modules	4	6.1	General	22
1.2	VortexBlue Combi Boilers (Internal and External models)	4	6.2	Ignition Electrode Setting	22
1.3	Control Panels	5	6.3	Air Damper Adjustment	22
			6.4	Air Adjuster Disc - 21kW only	22
2	Introduction	6	7	Servicing	23
2.1	Update to Main Installation Instructions	6	7.1	General	23
2.2	General	6	8	Burner	24
2.3	Low NOx Technology	6	8.1	General	24
2.4	Boiler Controls	6	8.2	Burner Features	24
2.5	Fuel Type	6	8.3	Digital Control Box	25
			8.4	Burner Operation	27
3	Technical Data	7	9	Fault Finding	28
3.1	Boiler Technical Data	7	9.1	Burner Fault Indication	28
3.2	Boiler Clearances	8	9.2	Burner Fault Diagnostics	28
3.3	Burner Settings	9	9.3	Riello RDB BLU Fault Finding Chart	29
3.4	Boiler Dimensions	10	10	Spare Parts	30
4	Installation	13	10.1	Riello RDB BLU Burner Parts List	30
4.1	General	13	10.2	Exploded View of Riello RDB BLU Burner	31
5	Electrical	13			
5.1	General	13			
5.2	Frost Protection	13			
5.3	VortexBlue Kitchen Utility and Kitchen/Utility System models	13			
5.4	VortexBlue External Modules	14			
5.5	VortexBlue Combi Boilers and External Combi Boilers	20			

1 User Instructions

These User Instructions are intended to assist the user in the operation of the Grant VortexBlue range of high efficiency oil fired boilers. Please refer to the section that applies to your particular boiler model.

1.1 VortexBlue Kitchen/Utility, Kitchen/Utility System Boilers and External Modules

The boiler is fully automatic once switched on, providing central heating (and also heating your domestic hot water if you have a hot water cylinder fitted).

For guidance on how to use your Grant VortexBlue Kitchen/Utility boiler (or Kitchen/Utility System boiler) please refer to the User Instructions for the Grant Vortex Kitchen/Utility boiler.

These are to be found at the back of the Installation Instructions supplied with the boiler.



NOTE

The Grant VortexBlue Kitchen/Utility (and Kitchen/Utility System) boilers differ from the standard version of the Grant Vortex, as follows:

- The use of the Riello RDB BLU blue flame burner – refer to Section 7 (installer section) of these Supplementary Instructions for details.**
- A new boiler control system with electronic temperature control and LED boiler function indication.**

1.1.1 Boiler Controls

Please refer to the following for details of the boiler control panels. For all other details refer to the User Instructions supplied with the boiler.

To access the control panel, pull off the front door panel from the boiler. The controls on the panel are as follows (refer to Figures 1-1 to 1-3 as appropriate).

- **Boiler On/Off switch**

This switches the boiler on and off. The boiler ON/OFF switch incorporates a 'mains on' neon which lights when the boiler is switched on. Please note that the 'mains on' neon does not necessarily indicate that the burner is firing. See Boiler Indicator Lights information in the next column.

When the ON/OFF switch is set to on, the POWER indicator LED on the control panel will also light. This also does not necessarily indicate that the boiler is firing.



NOTE

If the ON/OFF switch is set to off the boiler will NOT supply central heating or heat domestic hot water (if a hot water cylinder is connected to the boiler). The built-in frost thermostat will also not operate.

- **Service Switch (External Modules only)**

A Service switch is fitted to the control panel to allow the Service Engineer to test-fire the boiler.

- **Heating Thermostat**

This control allows the temperature of the water leaving the boiler to heat the radiators (and domestic hot water) to be adjusted. This will be set by the installer to the optimum temperature for efficient operation of the boiler. It should be left set in this position.

- **Boiler Indicator Lights**

These five red LEDs, located on the boiler control panel, indicate the operating situation of the boiler as below:

PUMP	Power to the system circulating pump
POWER	Mains power to the boiler is switched on
DEMAND	Demand for heating (and/or hot water) from the heating system controls.
OVERHEAT	Boiler overheat thermostat has operated and switched the boiler off.
BURNER	Power to the burner for it to operate.

- **Overheat Thermostat (Overheat Reset)**

The boiler is fitted with a safety overheat thermostat which will automatically switch off the boiler in the case of a control malfunction causing overheating.

- **System Pressure Gauge (Kitchen/Utility System models only)**

This is to indicate the water pressure in the sealed heating system.

1.1.2 Lighting the Boiler

Please follow the guidance for lighting the boiler given in the User Instructions supplied with the boiler.

If the reset push-button LED on the burner indicates a lockout (refer to Section 8.3.3), press the reset button to attempt to re-start the burner. If the burner then operates correctly the lockout may have been caused by a temporary fault that has now cleared. If the lockout persists the cause of the fault should be diagnosed and rectified.



NOTE

To operate the reset push-button it must be pressed in and briefly held (for at least one second) before releasing.

1.2 VortexBlue Combi Boilers (Internal and External models)

For guidance on how to use your Grant VortexBlue Combi boiler, please refer to the User Instructions for the Grant Vortex Combi boiler (or External Combi boiler).

These are to be found at the back of the Installation Instructions supplied with the boiler.

1.3 Control Panels

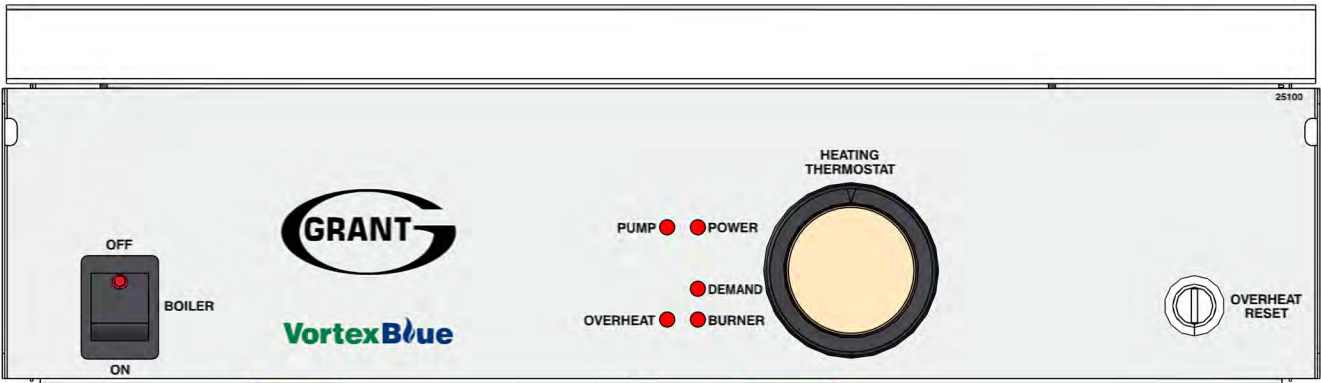

Figure 1-1: VortexBlue Kitchen/Utility Control Panel

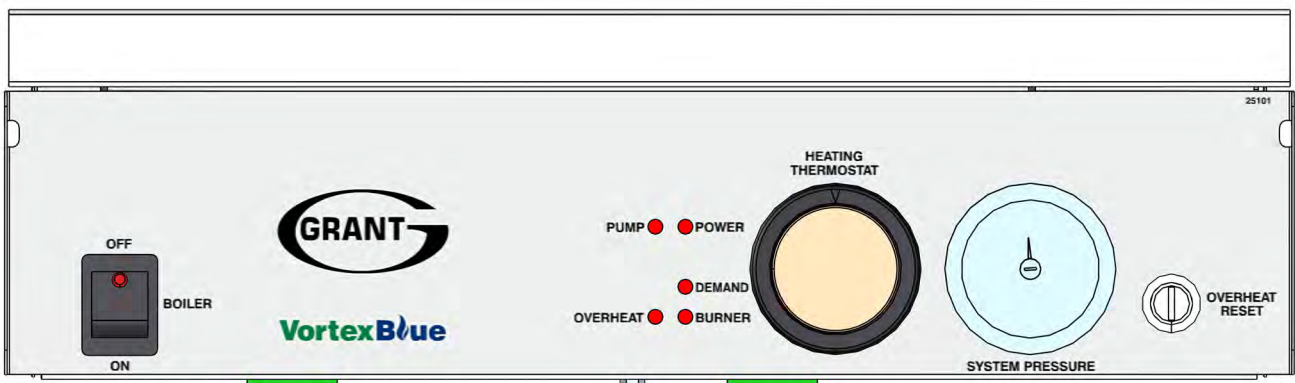

Figure 1-2: VortexBlue Kitchen/Utility System Control Panel

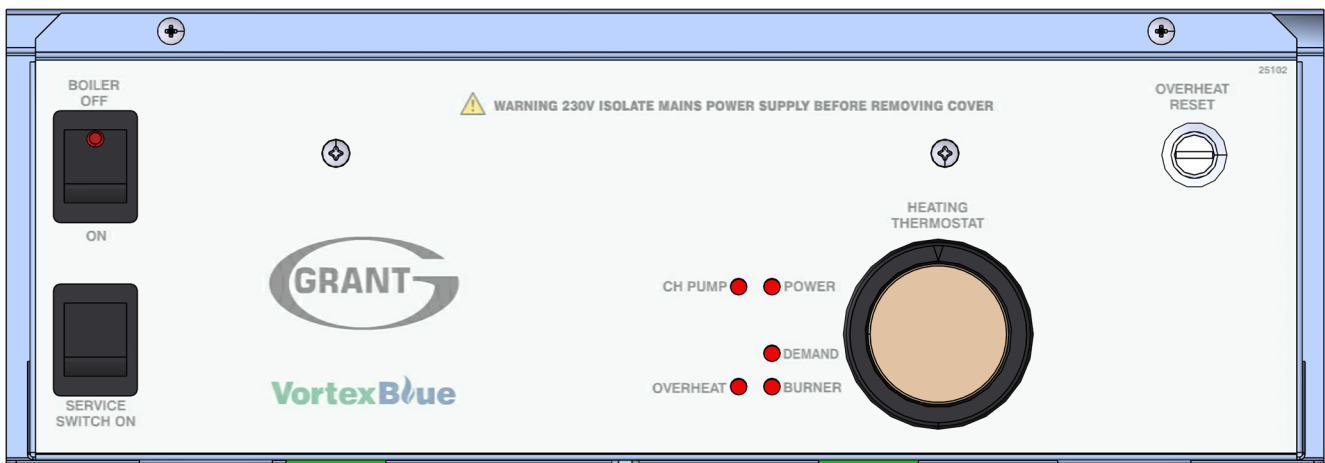

Figure 1-3: VortexBlue External Module Control Panel

2 Introduction



NOTE

These supplementary Instructions must be read in conjunction with the Vortex boiler Installation Instructions supplied with the boiler.

Both the Vortex boiler Installation Instructions and these Supplementary Instructions must be left with the User on completion of Installation and Commissioning.

2.1 Update to Main Installation Instructions

These Supplementary Instructions are designed to cover the differences between the Grant Vortex and the new Grant VortexBlue low NOx boilers, as much of the installation, commissioning, servicing and operation is identical to the standard Vortex boilers.

The following sections of the Vortex Installation Instructions (supplied with the boiler) have not been changed and should be referred to during the installation and commissioning of this boiler:

- Section 3 Oil Supply and Storage
- Section 5 Pipe Connections
- Section 6 Condensate Disposal
- Section 7 Sealed Systems
- Section 9 Flues and Air Supply
- Section 14 Health and Safety Information
- Section 16 Guarantee

2.2 General

The new Grant VortexBlue range of high efficiency low NOx oil fired boilers consists of 15 models including Kitchen/Utility, Kitchen/Utility System and External Modules as well as both Internal and External Combi boilers.

All models are available in three outputs – 21kW, 26kW and 36kW. The Kitchen/Utility, Kitchen/Utility System and External Modules are supplied factory set at the maximum outputs of 21kW, 26kW and 36kW but can be de-rated to a lower output on commissioning if required. Refer to Section 3.3 of these Supplementary Instructions for a full list of all models and outputs.



NOTE

Internal and External Combi boilers must be left at the factory set output and not de-rated to a lower output.

2.3 Low NOx Technology

Grant VortexBlue boilers are designed to meet both the forthcoming European Ecodesign (ErP) emissions limits due to be introduced in September 2018, and to maintain the high efficiencies expected of Grant Vortex oil fired boilers.

They combine the proven Grant condensing boiler technology with the Riello RDB BLU compact low NOx blue flame burners.

Grant VortexBlue boilers can be used with all the Grant flue system options available for the standard Vortex boilers. Refer to the Installation Instructions supplied with the boiler for details.

2.4 Boiler Controls

2.4.1 Combi Boilers

The Grant VortexBlue Combi boilers (internal and external) have the same electronic control system as fitted to the standard Vortex Combi models.

All wiring details for external controls (programmers, room thermostats, etc.) are given in Section 8 of the Vortex Combi Installation Instructions provided with the boiler.

2.4.2 Kitchen/Utility boilers and External Modules

The Grant VortexBlue Kitchen/Utility boilers and External Modules incorporate a new electronic control system based on the one used in the Grant Vortex Combi boilers.

This uses an electronic boiler thermostat and has LED lights to indicate the operating status of the boiler. For details on how to operate the boiler please refer to Section 1.

Refer to Section 5 of these Supplementary Instructions for further details and electrical connection diagrams.



NOTE

A service switch is fitted to the control panel of the external modules to allow the service engineer to test-fire the boiler.

When set to 'ON' the switch temporarily by-passes the external control system to operate the boiler.

This is a 'momentary' or non-latching switch that cannot be left set to 'ON'. The boiler will automatically revert to normal operation when 15 minutes have elapsed since it was last operated.

If required, this 15 minute override period can be stopped by switching the boiler ON/OFF switch 'OFF' and then back to 'ON'.

The boiler will then operate as normal under control of the external heating/hot water controls (timer, room thermostat or programmer).

2.5 Fuel Type

All VortexBlue boilers are designed for use with Kerosene (Class C2) only.

The use of any other fuel, e.g. Gas Oil (Class D), is not permitted with any of the VortexBlue boilers and may invalidate the product guarantee.

3 Technical Data

3.1 Boiler Technical Data

3.1.1 Kitchen/Utility, Kitchen/Utility System and External Modules

Table 3-1: Kitchen/Utility, Kitchen/Utility System and External Modules Technical Data

	Units	Kitchen/Utility and System			External Module		
		21kW	26kW	36kW	21kW	26kW	36kW
Water content	litres	19	19	21	19	19	21
	gall	4.2	4.2	4.7	4.2	4.2	4.7
Weight (dry)*	kg	130	130	144	143	143	162
	lbs	287	287	318	315	315	357
Maximum heat output (Kerosene)**	kW	21	26	36	21	26	36
	Btu/h	71 650	88 700	122 840	71 650	88 700	122 840
Flow connection		22mm	22mm	28mm	22mm	22mm	28mm
Return connection		22mm	22mm	28mm	22mm	22mm	28mm
Minimum flow rate ($\Delta T=10^{\circ}\text{C}$)	l/h	1 800	2 200	3 000	1 800	2 200	3 000
Minimum flow rate ($\Delta T=20^{\circ}\text{C}$)	l/h	900	1 100	1 500	900	1 100	1 500
Condensate connection		22 mm plastic pipe					
Flue diameter (conventional)		100 mm (4 inches)					
Waterside resistance ($\Delta T=10^{\circ}\text{C}$)	mbar	26					
Waterside resistance ($\Delta T=20^{\circ}\text{C}$)	mbar	9.5					
Maximum static head	m	28					
Minimum circulating head	m	1					
Boiler thermostat range	$^{\circ}\text{C}$	65 to 78					
Limit (safety) shut off temperature	$^{\circ}\text{C}$	111 \pm 3					
Maximum hearth temperature	$^{\circ}\text{C}$	Less than 50					
Electricity supply		230/240V 1ph 50Hz fused at 5A					
Burner motor power	W	90					
Absorbed motor power	W	0.15					
Starting current	A	2.0					
Running current	A	0.85					
Oil connection		¼" BSP male (on end of flexible fuel hose)					
Conventional flue draught	N/m ²	Minimum: 8.7 - maximum: 37					
	in wg	Minimum: 0.035 - maximum: 0.15					
Maximum operating pressure - sealed/open system	bar	2.0					
Maximum operating pressure - pressure relief valve	bar	2.5					

* Weight includes burner but excludes flue.

** Factory setting (maximum output). Refer to Section 3.3 for other boiler outputs.

3.1.2 Combi and External Combi

Table 3-2: Combi and External Combi Technical Data

	Units	Combi			External Combi		
		21kW	26kW	36kW	21kW	26kW	36kW
Water content (including 32 litre primary store)	litres	48.5	48.5	53.5	48.5	48.5	53.5
	gall	10.7	10.7	11.8	10.7	10.7	11.8
Weight (dry)*	kg	160	177	200	181	206	225
	lbs	353	390	441	399	454	496
Maximum heat output (Kerosene)	kW	21	26	36	21	26	36
	Btu/h	71 650	88 700	122 840	71 650	88 700	122 840
Flow and return connections	mm	22	22	28	22	22	28
Minimum flow rate $\Delta T=10^{\circ}\text{C}$	l/h	1 800	2 200	3 000	1 800	2 200	3 000
Minimum flow rate $\Delta T=20^{\circ}\text{C}$	l/h	900	1 100	1 500	900	1 100	1 500
Condensate connection		22 mm plastic pipe					
Flue diameter (conventional)		100 mm (4 inches)					
Waterside resistance $\Delta T=10^{\circ}\text{C}$	mbar	28.5	28.5	26	28.5	28.5	26
Waterside resistance $\Delta T=20^{\circ}\text{C}$	mbar	10.0	10.0	9.5	10.0	10.0	9.5
Boiler stat range	$^{\circ}\text{C}$	65 to 78					
Limit stat shut off temperature	$^{\circ}\text{C}$	111 \pm 3					
Maximum hearth temperature	$^{\circ}\text{C}$	Less than 50					
Electricity supply		230/240V 1ph 50Hz fused at 5A					
Burner motor power	W	90					
Absorbed motor power	W	0.15					
Starting current	A	2.0					
Running current	A	0.85					
Oil connection		1/4" BSP male (on end of flexible fuel hose)					
Conventional flue draught	N/m ²	Minimum: 8.7 - maximum: 37					
	in wg	Minimum: 0.035 - maximum: 0.15					
Maximum operating pressure - pressure relief valve	bar	2.5					

* Weight includes burner but excludes flue

3.2 Boiler Clearances

Adequate clearance must be left for servicing the boiler.

For guidance on the clearances required, please refer to the 'Boiler Location' information given in the 'Installation Information' section of the Installation Instructions supplied with the boiler.

3.3 Burner Settings

Table 3-3: Burner settings

Boiler models (burner type)	Heat output		Nozzle	Oil pressure (bar)	Smoke No.	Burner head type	Burner head/disc setting	Fuel flow rate (kg/h)	Flue gas temp. (°C)	CO ₂ (%)
	(kW)	(Btu/h)								
Kitchen/Utility 21 Kitchen/Utility System 21 External Module 21 (RDB2.2 BG1 BLU)	* 21 *	71 650	0.60/80°ES	8.5	0 - 1	BG1	N/A	1.78	75 - 85	12.0
	18	61 400	0.55/80°ES	8	0 - 1	BG1	N/A	1.53	70 - 80	12.0
	16	54 600	0.40/80°ES	10.5	0 - 1	BG1	B	1.36	65 - 75	12.0
	15	51 200	0.40/80°ES	9	0 - 1	BG1	B	1.28	65 - 75	12.0
Kitchen/Utility 26 Kitchen/Utility System 26 External Module 26 (RDB2.2 BG1 BLU)	* 26 *	88 700	0.65/80°ES	10	0 - 1	BG1	N/A	2.19	75 - 80	12.0
	23	78 475	0.65/80°ES	8.5	0 - 1	BG1	N/A	1.94	70 - 75	12.0
	21	71 650	0.60/80°ES	8.5	0 - 1	BG1	N/A	1.78	65 - 70	12.0
Kitchen/Utility 36 Kitchen/Utility System 36 External Module 36 (RDB2.2 BG3 BLU)	* 36 *	123 000	0.85/80°ES	11	0 - 1	BG3	N/A	2.99	75 - 80	12.0
	31.5	107 500	0.85/80°ES	9	0 - 1	BG3	N/A	2.62	70 - 75	12.0
	26	88 700	0.65/80°ES	10	0 - 1	BG3	N/A	2.19	65 - 70	12.0
Combi 21 External Combi 21 (RDB2.2 BG1 BLU)	21.0	71 650	0.60/80°ES	8.5	0	BG1	N/A	1.8	73	12.0
Combi 26 External Combi 26 (RDB2.2 BG1 BLU)	26.0	88 700	0.65/80°ES	10.0	0	BG1	N/A	2.0	72	12.0
Combi 36 External Combi 36 (RDB2.2 BG3 BLU)	36.0	123 000	0.85/80°ES	11.0	0	BG3	N/A	2.8	78	12.0

Notes:

1. The data given above is approximate only.
2. The above settings may have to be adjusted on site for the correct operation of the burner.
3. Gas Oil and Bio Kerosene are NOT suitable for use with Grant VortexBlue boiler range
4. The flue gas temperatures given above are ± 10%.
5. When commissioning, the air damper must be adjusted to obtain the correct CO₂ level.
6. * Factory settings: 15/21 - 21kW, 21/26 - 26kW, 26/36 - 36kW
7. When setting the 15/21 to 15kW or 16kW, the burner air adjuster disc requires repositioning. Refer to Section 6 (Commissioning).
8. The installer must amend the boiler data label if the output is changed.

3.4 Boiler Dimensions

All dimensions in the following diagrams are in millimetres.

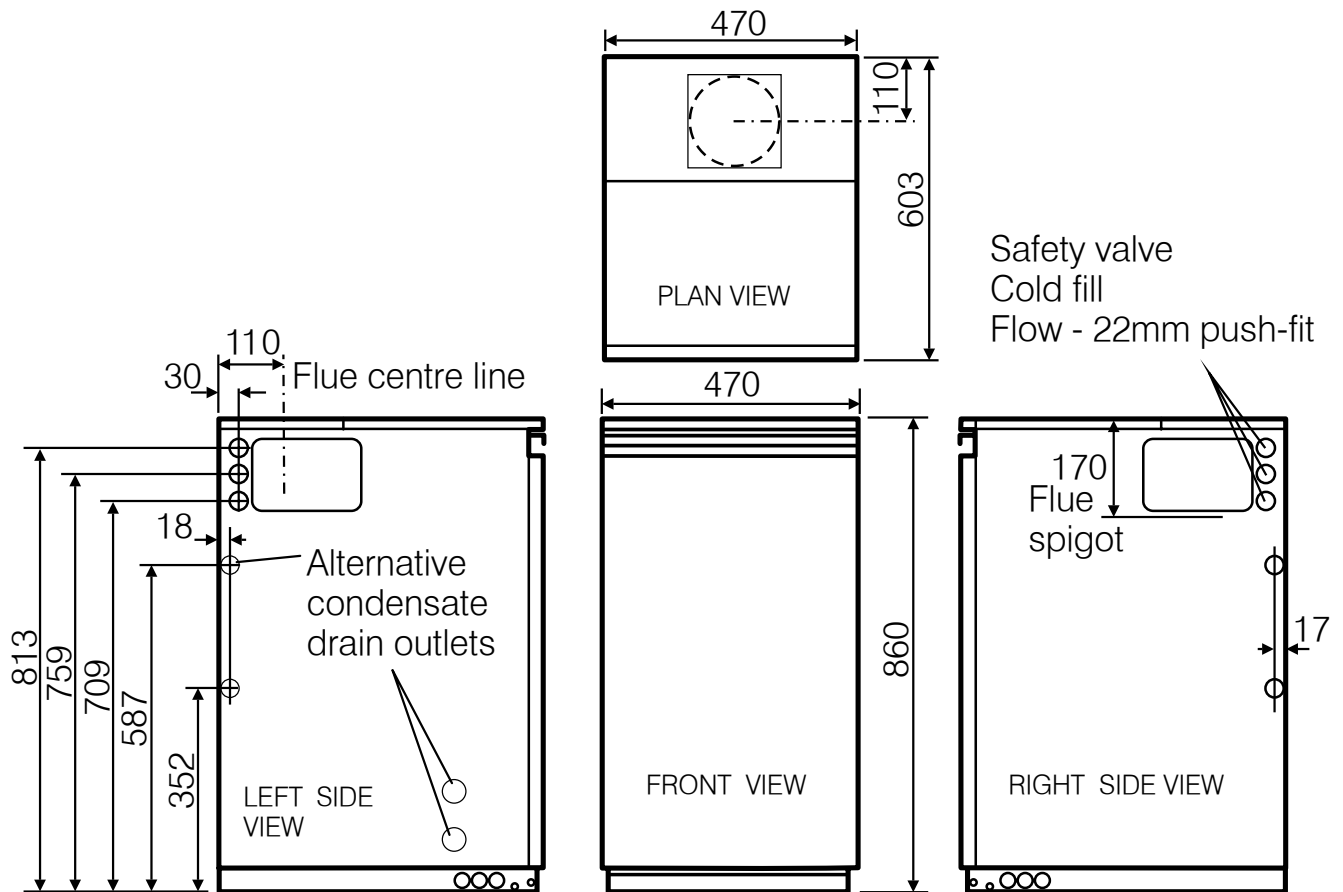

Figure 3-4: 21 and 26kW Kitchen/Utility and System dimensions

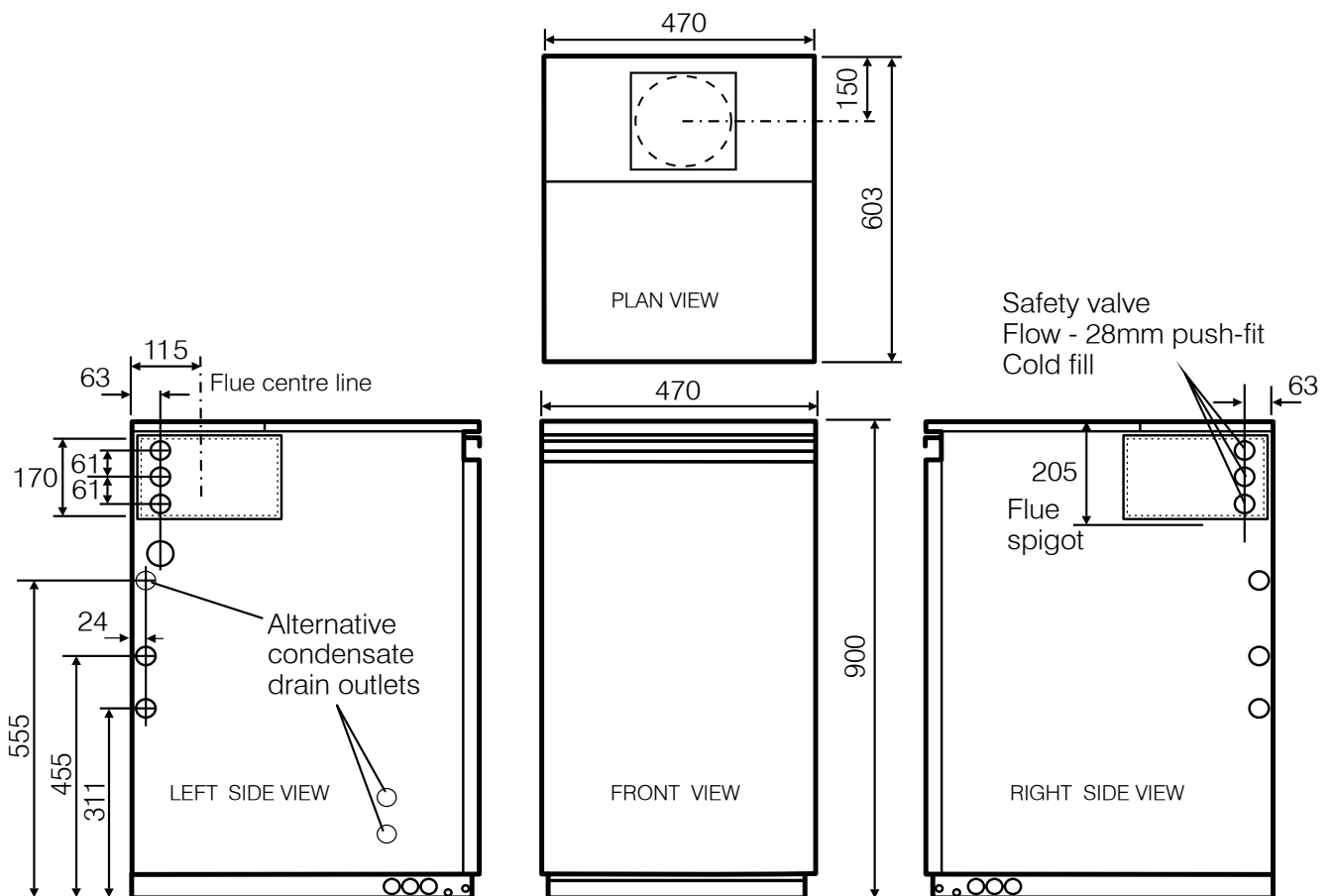

Figure 3-5: 36kW Kitchen/Utility and System dimensions

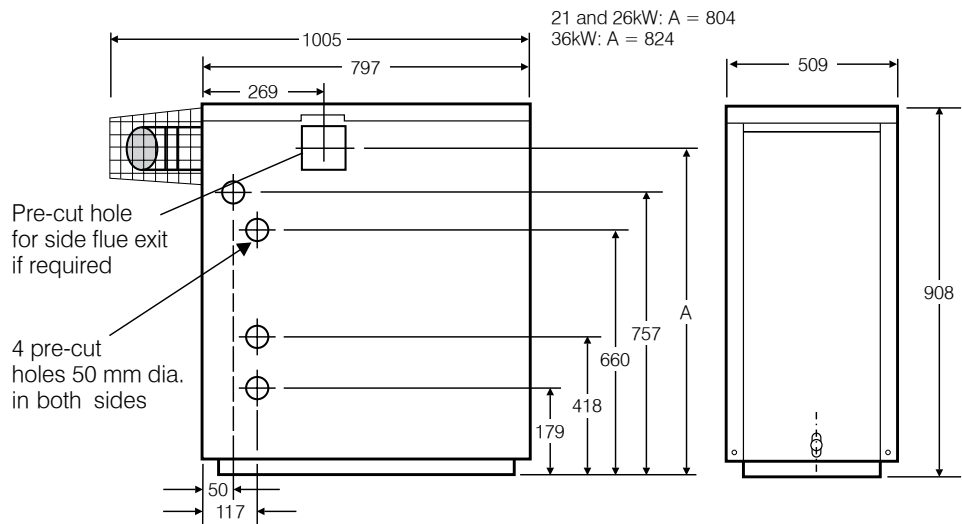
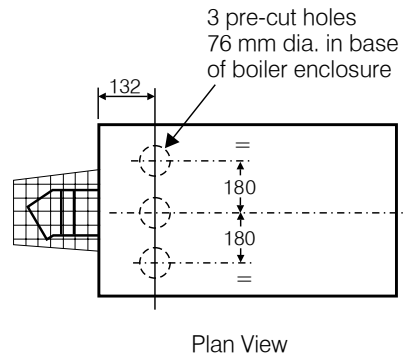

Figure 3-6: 21, 26 and 36kW External Module dimensions

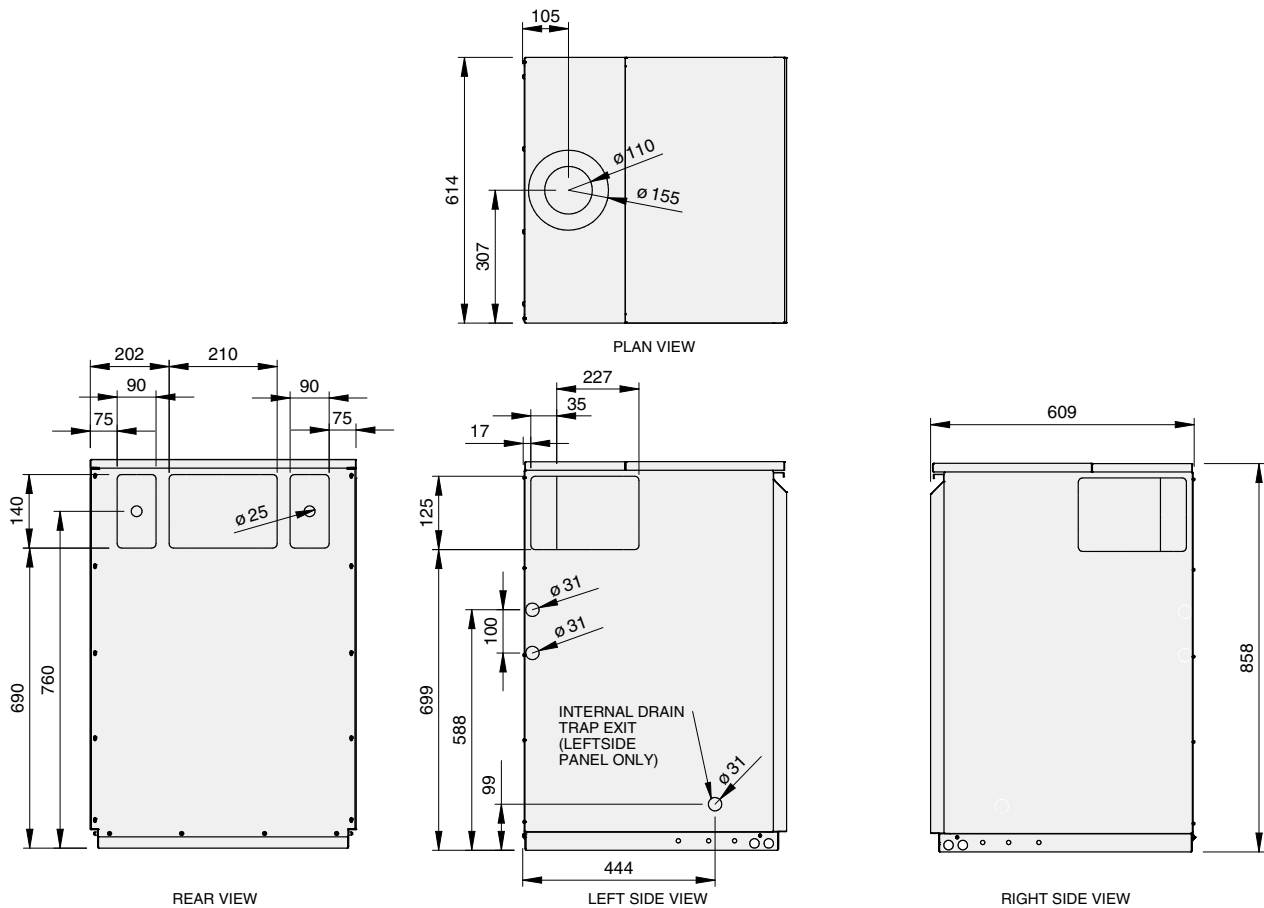

Figure 3-7: 21 and 26kW Internal Combi dimensions

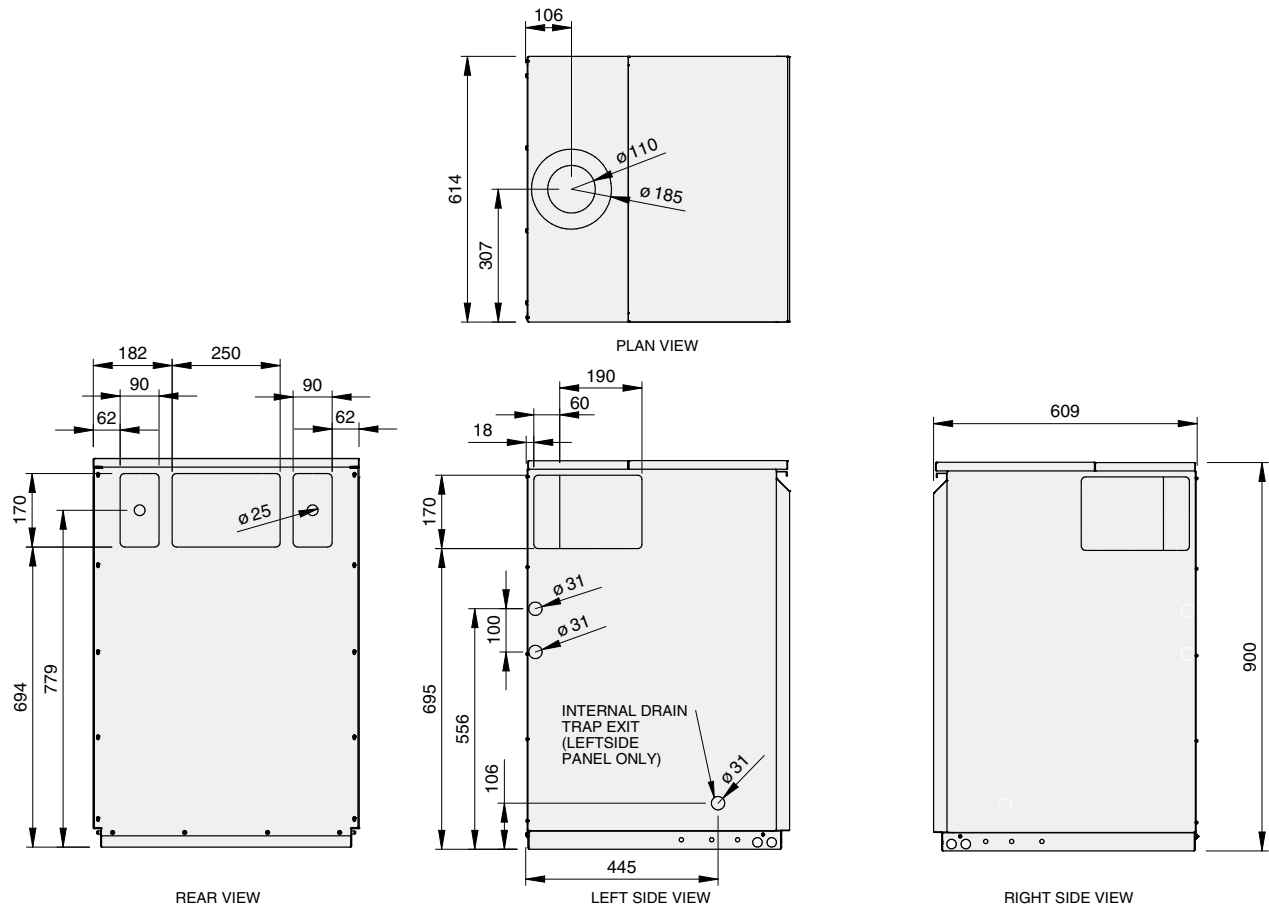

Figure 3-8: 36kW Internal Combi dimensions

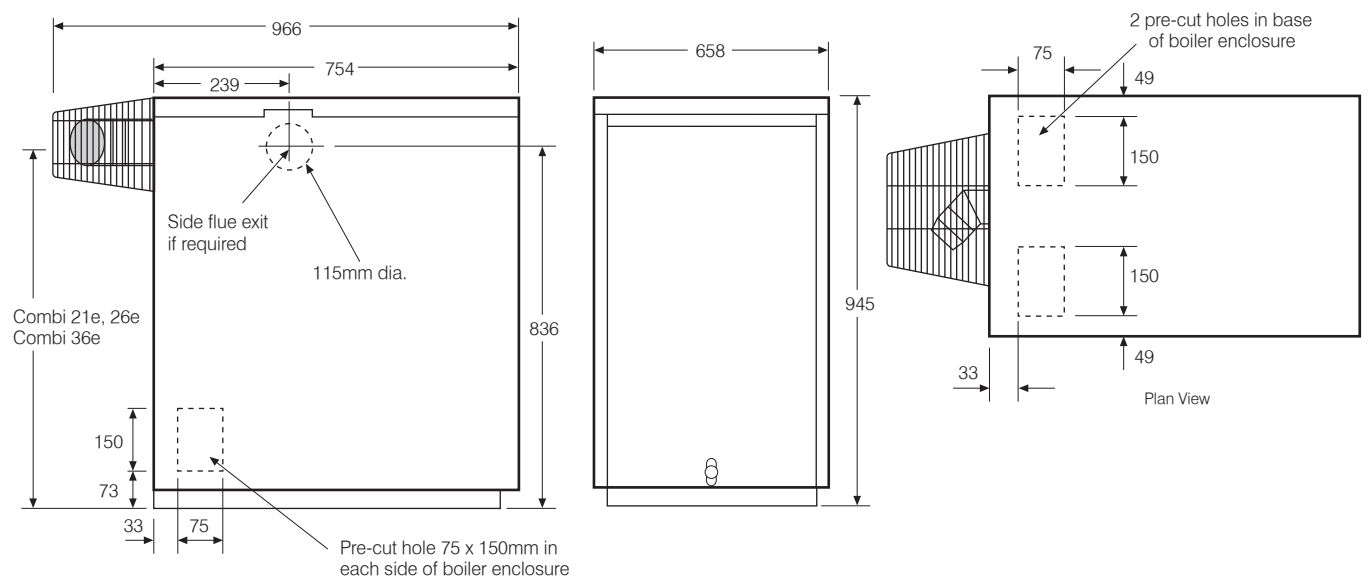

Figure 3-9: 21, 26 and 36kW External Combi dimensions

4 Installation

4.1 General

For full details on the installation of this boiler, please refer to the following sections of the Installation Instructions supplied with the boiler:

- Installation Information
- Pipe Connections
- Condensate Disposal
- Sealed Systems
- Flue System & Air Supply

5 Electrical

5.1 General

For details on the electrical installation requirements for this boiler please refer to the Installation Instructions supplied with this boiler in conjunction with the information given below.

5.2 Frost Protection

The Kitchen/Utility, Kitchen/Utility System and External Modules are all fitted with pre-set internal frost protection.

This will automatically start the circulating pump if either:

- a) The air temperature (sensed on the boiler control PCB) falls below 5°C, or
- b) The water temperature (sensed by the boiler control thermistor) falls below 8°C

If after fifteen minutes the air temperature exceeds 10°C or the water temperature exceeds 15°C the circulating pump will stop.

However, if after fifteen minutes either the air or water temperature is less than 10°C, the burner is automatically fired until the water temperature reaches 30°C, when the burner stops and there is a pump overrun of two minutes.

Also, to protect any exposed heating system pipework, it is recommended that an 'external' frost thermostat is also installed. This frost thermostat will operate in parallel with the internal frost protection of the boiler.

It should be sited within the house in such a place that it can detect any rise and fall in the ambient air temperature, i.e. in a room with a radiator.

Where the frost thermostat is installed outside the house (to protect a boiler installed in an external boiler room or garage) or in an attic, it is recommended that it be used in conjunction with a pipe thermostat to avoid unnecessary and wasteful overheating of the property. The pipe thermostat should be located on the boiler return pipe, and set to operate at 30°C.

For connection details please refer to Figures 5-4 and 5-5



NOTE

For total system protection against freezing, particularly during extended periods without electrical power, Grant recommend the use of a combined heating system antifreeze and corrosion inhibitor, used in accordance with the manufacturer's instructions.

5.3 VortexBlue Kitchen/Utility and Kitchen/Utility System models

5.3.1 Connecting Power Supply, Pump and Control System

The boiler requires both a switched mains power supply, from an external programmer or control system, in addition to a permanent live supply.



NOTE

Do not interrupt the permanent mains supply to the boiler with any external control, e.g. a timer, programmer, or room thermostat.

There is no facility in the Grant VortexBlue Kitchen/Utility and Kitchen/Utility System boilers for the fitting of a plug-in timer or programmer.

A 4-core cable (3-core and earth) is required to connect the power supply and heating controls to the boiler.

On Kitchen/Utility models a 3-core cable (2-core and earth) is required to connect the circulating pump to the boiler.

For control system wiring please refer to Figures 5-4 and 5-5



NOTE

Ensure that the route and length of the supply and pump cables are such that the boiler control panel can be fully hinged down without needing to disconnect them from the terminal block.

The procedure is as follows:

1. Lift off the boiler top front casing panel, if it has not already been removed.
2. Loosen (do not remove) the four screws securing the control panel to the side panels, hinge the panel forward and allow it to drop down to gain access to the top of the panel.
3. Remove the two screws securing the terminal block cover and lift off the cover.
4. Remove the screws securing the cable clamp and open clamp.
5. Route the supply cable through the hole in the rear panel (using the grommet supplied) and up to the control panel
6. Pass the 4-core cable through the cable clamp and connect to the boiler control panel terminals as follows:
 - Green/Yellow to mains earth (terminal 1)
 - Blue to mains neutral (terminal 2)
 - Brown to mains live (terminal 3)

- Black to switched live (terminal 19)
- On Kitchen/Utility models - pass the 3-core cable from the pump through the cable clamp and connect to the boiler control panel terminals as follows:
- Green/Yellow to pump earth (terminal 4)
 - Blue to pump neutral (terminal 5)
 - Brown to pump live (terminal 6)
7. Tighten the cable clamp and refit the terminal block cover
 8. Re-connect the electrical supply and check operation of heating system controls (programmer, room thermostats, etc.).
 9. Refer to Instructions provided with the programmer for operation and setting.
 10. Leave the Programmer and Thermostat Instructions with the user after installation for their future reference.

5.3.2 Circulating Pump

On the Kitchen/Utility System models, the circulating pump is factory fitted within the boiler enclosure and the pump is wired to the pump terminals on the control panel terminal block.

On Kitchen/Utility models the pump should also be connected directly to the control panel terminal block. Refer to Section 5.3.1.

Connected this way allows the pump to be isolated using the Boiler ON/OFF switch, on the boiler control panel, for servicing or maintenance work.

Also, the boiler control automatically provides a short pump 'overrun' (two minutes) after the burner is shut down (when the heat demand is interrupted), e.g. when the room thermostat is satisfied. This pump overrun will not occur if the boiler power supply is interrupted, e.g. if the boiler ON/OFF switch is set to off.

5.4 VortexBlue External Modules

5.4.1 Connecting Power Supply, Pump and Control System

The boiler requires both a switched mains power supply, from an external programmer or control system, in addition to a permanent live supply.



NOTE

Do not interrupt the permanent mains supply to the boiler with any external control, e.g. a timer, programmer, or room thermostat.

There is no facility in the Grant VortexBlue External Module for the fitting of a plug-in timer or programmer.

A 4-core cable (3-core and earth) is required to connect the power supply and heating controls to the boiler.

A 3-core cable (2-core and earth) is required to connect the circulating pump to the boiler.

For control system wiring, refer to Figures 5-8 and 5-9.



NOTE

Ensure that the route and length of the supply cable is such that the boiler control panel can be fully hinged down without disconnecting the supply cable from the terminal block.

The procedure is as follows:

1. Remove the module front door panel, if it has not already been removed.
2. Remove the four screws securing the front of the control panel and allow it to drop down to gain access to the top of the panel.
3. Remove the screws securing the cable clamp and open clamp.
4. Route the supply and pump cables up to the control panel.
5. Pass the 4-core cable through the cable clamp and connect to the boiler control panel terminals as follows:
 - Green/Yellow to mains earth (terminal 1)
 - Blue to mains neutral (terminal 2)
 - Brown to mains live (terminal 3)
 - Black to switched live (terminal 19)
6. Pass the 3-core cable from the pump through the cable clamp and connect to the boiler control panel terminals as follows:
 - Green/Yellow to pump earth (terminal 4)
 - Blue to pump neutral (terminal 5)
 - Brown to pump live (terminal 6)
7. Tighten the cable clamp and refit the front of the control panel.
8. Re-connect the electrical supply and check operation of heating system controls (programmer, room thermostats, etc.).
9. Refer to Instructions provided with the programmer for operation and setting.
10. Leave the Programmer and Thermostat Instructions with the user after installation for their future reference.

5.4.2 Connection of the Circulating Pump

The circulating pump should be connected directly to the control panel terminal block. Refer to Section 4.4.1.

Connecting the pump in this way allows it to be isolated using the Boiler On/Off switch, on the boiler control panel, for servicing or maintenance work.

Also, when the pump is connected this way, the boiler control automatically provides a short pump 'overrun' (2 minutes) after the burner has shut down (when the heat demand is interrupted), e.g. when the room thermostat is satisfied. This pump overrun will not occur if the boiler power supply is interrupted, e.g. if the boiler ON/OFF switch is set to off.

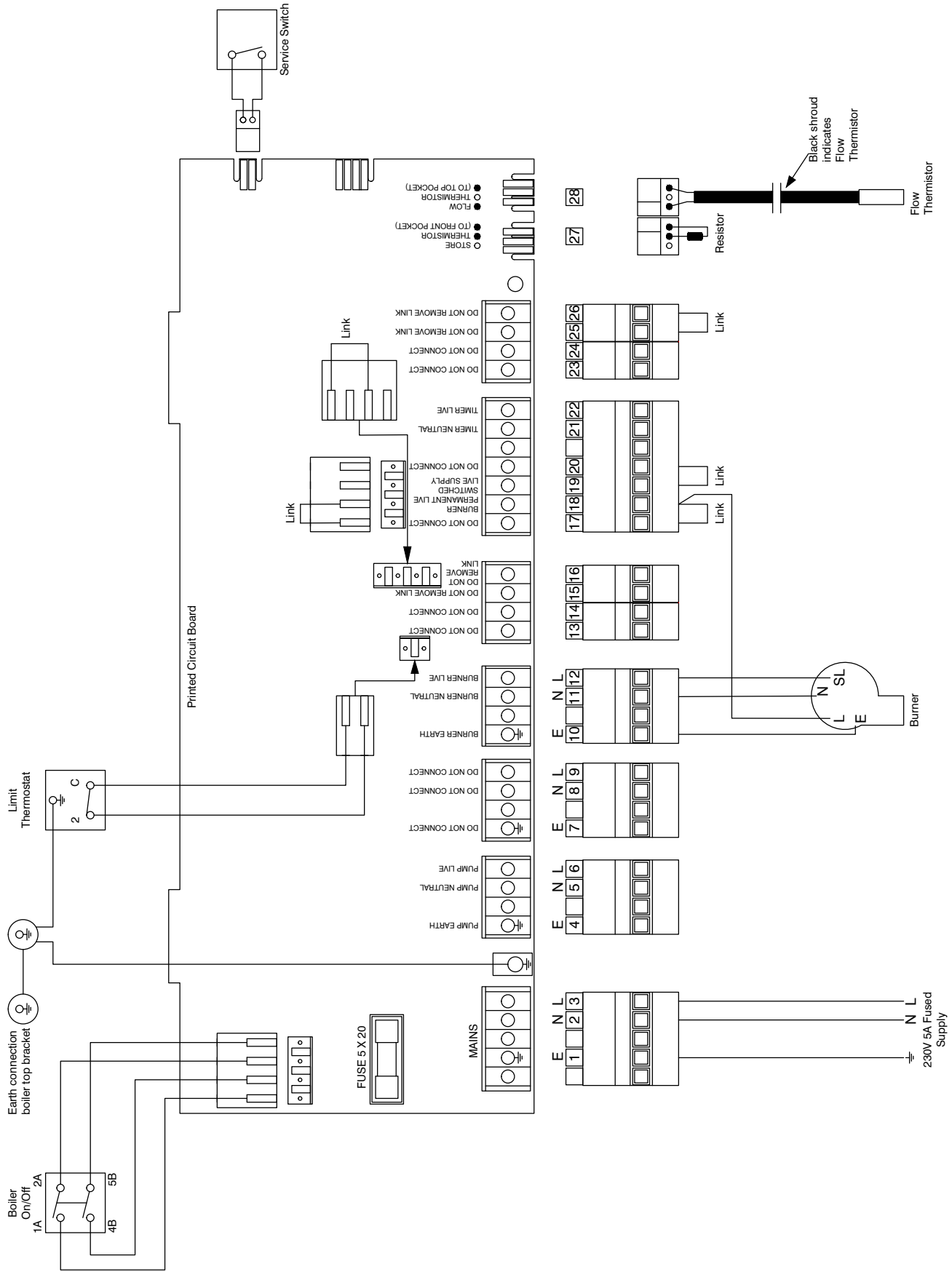

Figure 5-3: VortexBlue External Module control panel wiring diagram

NOTE

Earth and some Neutral connections have been excluded for clarity.
All switches are shown in the closed position.

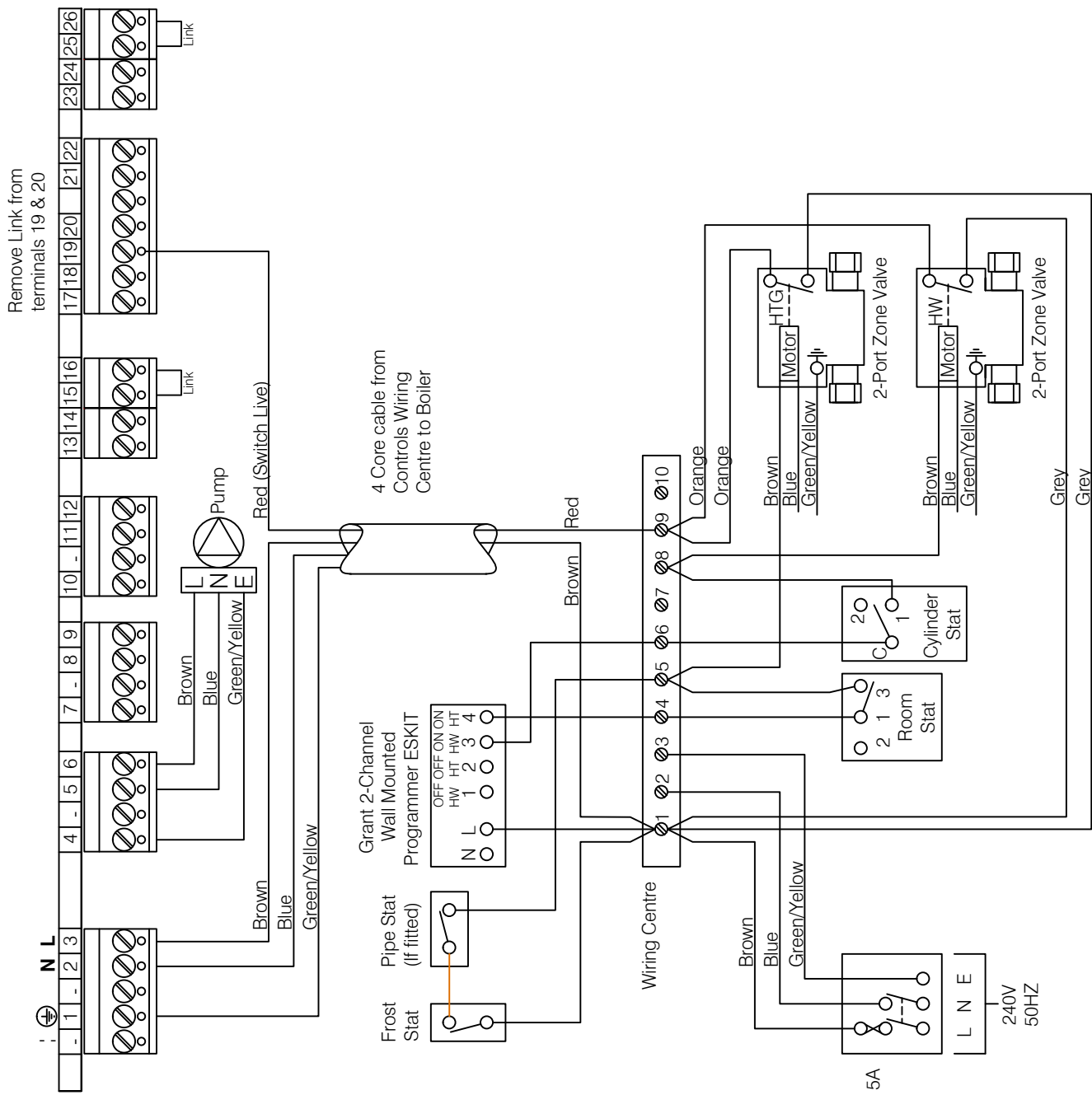

Figure 5-4: VortexBlue Kitchen/Utility, Kitchen/Utility System and External Module with S-plan type control system wiring diagram

5.5 VortexBlue Combi and External Combi Boilers

5.5.1 Connecting the Power Supply and Control System

For details on the electrical installation requirements for the Combi or External Combi, please refer to Section 8 of the Installation Instructions supplied with this boiler.



Figure 5-6 below replaces Figure 8-1 in the Combi boiler Installation Instructions.

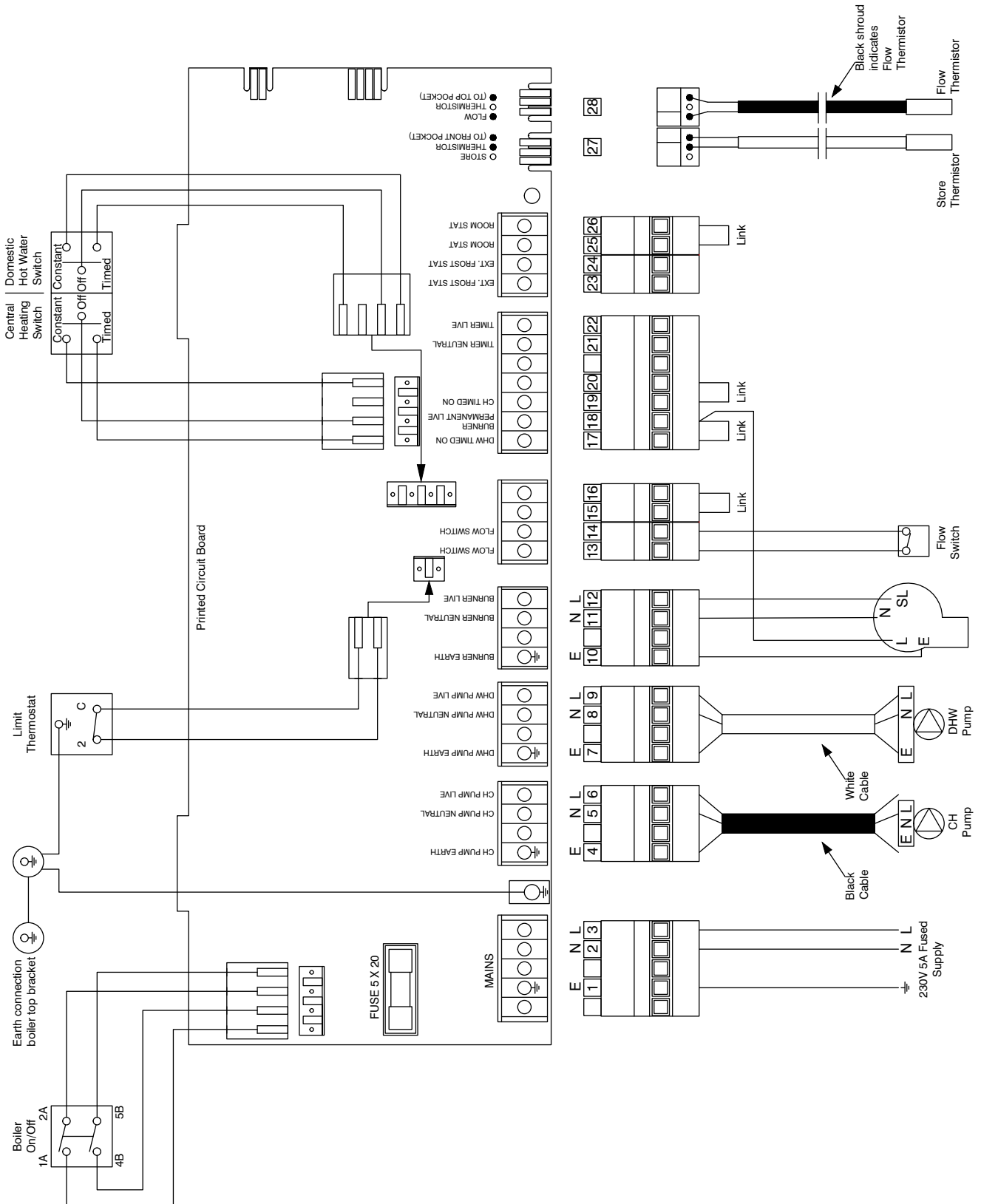

Figure 5-6: VortexBlue Internal Combi control panel wiring diagram

6 Commissioning

6.1 General

To commission the boiler and burner follow the procedure given in the Section 10 of the Vortex (or Vortex Combi) Installation Instructions supplied with the boiler.

6.2 Ignition Electrode Setting

Before first firing the boiler ensure that the burner ignition electrodes are correctly set.



NOTE

The ignition electrode details given in Figure 6-1 below replaces that given in the Installation Instructions supplied with the boiler.

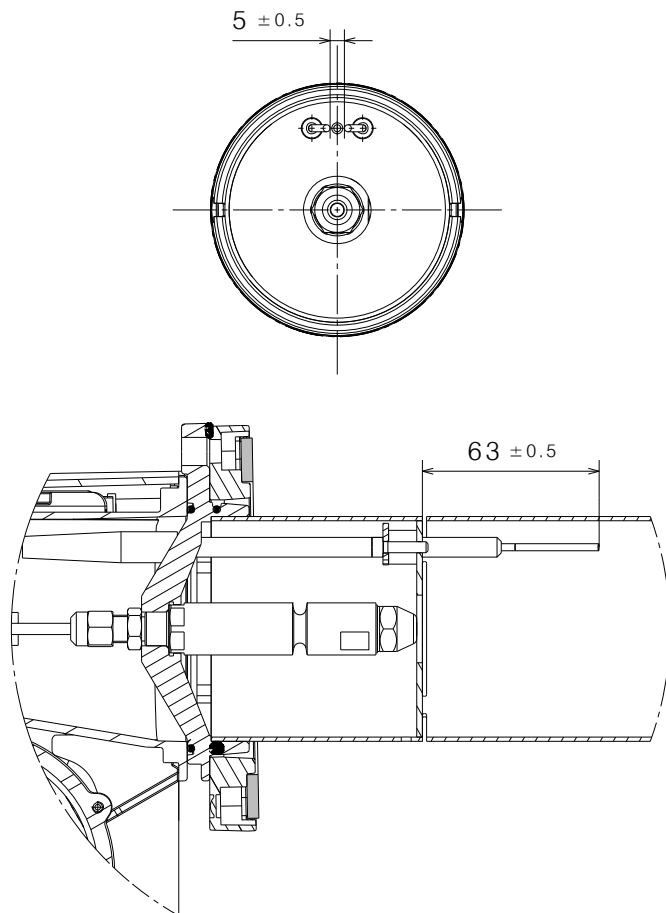

Figure 6-1: Riello RDB BLU ignition electrode setting

6.3 Air Damper Adjustment

Use a 3mm Allen key to adjust the air damper. Refer to Figure 6-2.

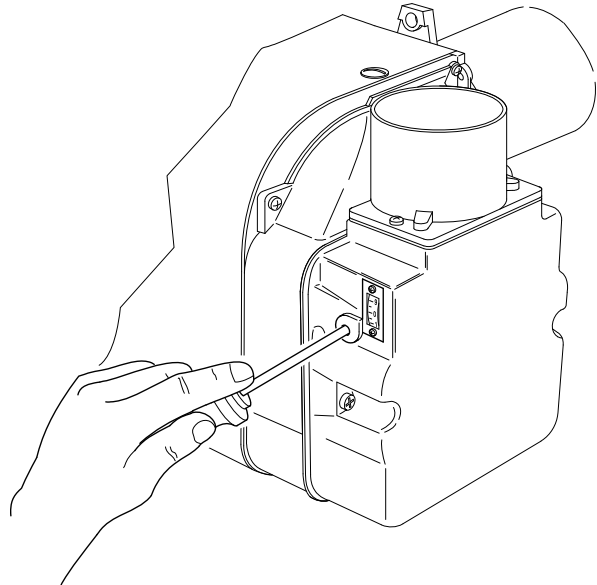

Figure 6-2: Air damper adjustment

6.4 Air Adjuster Disc – 21kW only

The boiler is supplied with an air adjuster disc loose in the accessories bag.

To fit and position the air adjuster disc when downrating the 21kW boiler to 15 or 16kW output:

1. Ensure the boiler is isolated from the electrical supply.
2. Remove the burner from the boiler.
3. Undo the two screws (1) and remove the air damper assembly from the side of the burner.
4. Remove the screw (2) from the centre of where the air adjuster disc will be fitted.
5. Position the disc such that the disc setting 'B' (corresponding to 15 or 16kW output setting – refer to Section 3.3) is located against the cast boss on the fan housing.
6. Replace the screw in the centre of the air adjuster disc and tighten.
7. Re-fit the air damper assembly to the side of the burner and reassemble in reverse order.

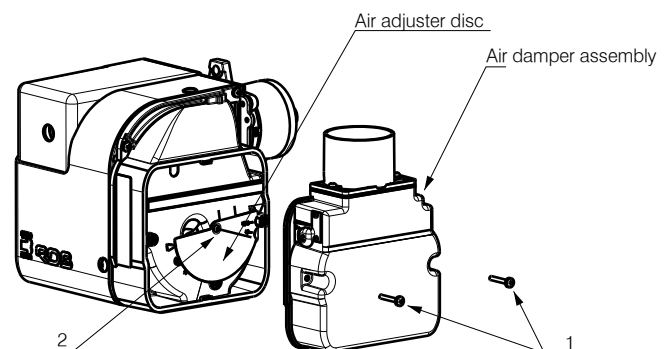

Figure 6-3: Fitting the air adjuster disc

7 Servicing

7.1 General

To service the boiler and burner follow the procedure given in the Section 11 of the Vortex boiler (or Vortex Combi boiler) Installation Instructions supplied with the boiler.

8 Burner

8.1 General

All Grant VortexBlue boilers are fitted with a Riello RDB BLU blue flame burner. This has been designed to operate with reduced NOx emissions that meet the forthcoming European Ecodesign emissions regulations.

From September 2018 the maximum permissible NOx level for oil fired boilers is 120mg/kWh. All Grant VortexBlue boilers, fitted with the Riello RDB BLU burner, will operate well below this minimum level and thus fully comply with these emissions regulations when they come into effect.

8.2 Burner Features

The Riello RDB BLU blue flame burner fitted to the Grant VortexBlue boilers is very similar to the Riello RDB 'yellow flame' burners, such as those fitted to the Vortex range of oil fired boilers.

The main differences with the blue flame burner are as follows:

- An Ultra Violet (UV) sensor is used – the blue flame cannot be detected by the usual photocell.
- A digital control box is used – the UV cell cannot be used with the usual 'analogue' control box.
- A clear reset button (on the control box) with burner status and fault identification by different coloured indicator lights.
- A longer combustion head – to allow the necessary recirculation of the combustion gases.
- A post purge following flame shut off – requiring a permanent live to the burner in addition to the usual switched live.

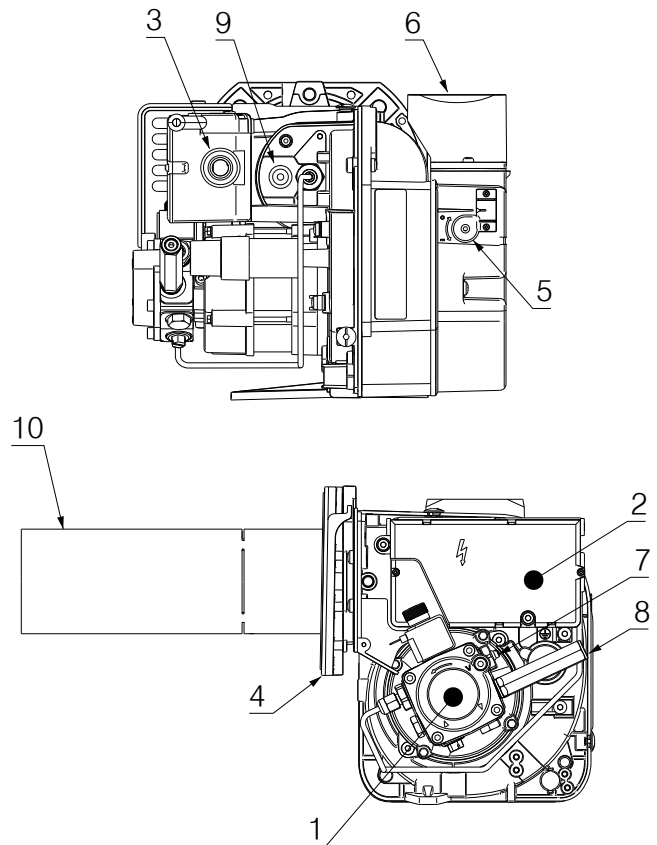

Figure 8-1: Burner components

Table 8-2: Burner components key

Key	Description
1	Oil pump
2	Digital control box
3	Reset push-button with lockout lamp
4	Flange with insulating gasket
5	Air damper adjustment screw
6	Snorkel (balanced flue)
7	Pump pressure adjustment screw
8	Pressure gauge port
9	UV sensor
10	Combustion head

8.3 Digital Control Box

The digital control box fitted to this burner has several different features compared to the more commonly used 'analogue' control box.

8.3.1 Reset Push-button

This is a clear (transparent) button that will indicate the operating status of the burner and also burner faults depending on the colour of the indicator LED visible through the reset button.

If there is no heat demand to fire the burner, the indicator LED will be off, i.e. no colour visible through the reset push button.

Refer to Figure 8-1 for the location of the control box and reset push-button.

If the reset push-button LED is indicating a lockout (refer to Section 8.3.3), press the reset button to attempt to re-start the burner. If the burner then operates correctly the lockout may have been caused by a temporary fault that has now cleared. If the lockout persists the cause of the fault should be diagnosed and rectified.



NOTE

To operate the reset push-button it must be pressed in and briefly held (for at least one second) before releasing.



NOTE

The burner can only be reset 5 times consecutively, after which the mains power supply has to be switched off and then back on for a further 5 reset attempts to be available.

8.3.2 Operating Status Indication

From start up the operating status of the burner is displayed via the reset push-button indicator LED on the control box. Refer to Table 8-3.

8.3.3 Burner Fault Indication

Whenever a burner lockout occurs the cause is displayed via the reset push-button indicator LED on the control box. Refer to Table 8-4.

8.3.4 Last Lockout Display

The control box memorises the details of the last lockout that occurred and this information can be recalled and displayed by the reset push-button indicator LED.

To operate this function:

- Press and hold the reset push-button for 25 seconds
- During this time the reset push button indicator LED will first flash RED (twice) and then flash GREEN (once) and then GREEN again (three times)
- As soon as it flashes GREEN four times release the reset push-button immediately
- The reset push-button indicator LED will then display the last lockout indication, e.g. constant red.
- Refer to the Fault Diagnostics table (Table 9-2) in Section 9 of these Supplementary Instructions to identify the fault from the indicator LED sequence.

The lockout fault will only be displayed for a period of 10 seconds. If required, this period can be extended by re-pressing the reset push-button during the display of the lockout. The lockout display will then be extended by a further 10 seconds.

Table 8-3: Burner operating status indicator

Status	Reset push-button colour	Seconds		Notes
OFF	OFF	-	-	
Pre-purge	ORANGE blinking	0.5	0.5	
Safety time	GREEN blinking	0.5	0.5	
Normal operating position	GREEN	-	-	Steady ON

Table 8-4: Burner operating status indicator

Status	Reset push-button colour	Seconds		Notes
Extraneous light (false flame signal)	GREEN, RED blinking alternately	0.5	0.5	
Frequency supply error	ORANGE	-	-	Steady ON
Voltage monitor error	ORANGE, GREEN fast blinking alternately	0.2	0.2	
Reset push-button / remote reset anomaly	GREEN, RED fast blinking alternately	0.2	0.2	
Lockout for no flame after safety time	RED	-	-	Steady ON Go to box A*
Lockout for false flame signal	RED blinking	0.5	0.5	Go to box B*
Lockout for maximum number of re-cycles	RED fast blinking	0.2	0.2	Go to box C*
Lockout for fan motor error	RED, ORANGE blinking inverted	2.5	0.5	Go to box D*
Lockout for oil valve error	RED, GREEN blinking inverted	2.5	0.5	Go to box E*
Lockout for eeprom error	ORANGE, GREEN blinking alternately	0.5	0.5	Go to box F*

* Refer to the fault finding chart - Section 8.3.

8.3.5 Removal of Control Box



WARNING

Before removing the control box from the burner, or opening the control box cover, isolate the electrical supply to the boiler.

To remove the control box proceed as follows (referring to Figure 8-5):

- Unscrew and remove screw (1) and open control box cover (2).
- Disconnect all plugs from the control box terminals.
- Unscrew the retaining finger nut and remove the solenoid coil (3) from the oil pump.
- Unscrew and remove the two screws (4) and remove the control box from the burner.
- Disconnect the two ignition leads from the ignition connections on rear of control box.
- Refit the control box to the burner using the reverse of the above procedure.

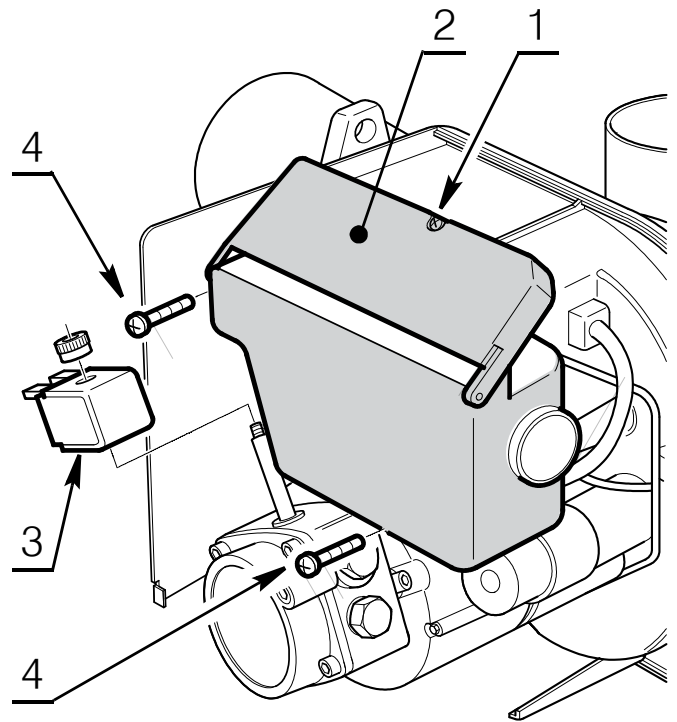

Figure 8-5: Removal of control box

8.4 Burner Operation

8.4.1 Burner Operating Times

Table 8-6: Burner operating times

Symbol	Description	Value (seconds)
t0	Standby: the burner is waiting for a heat request	-
t1	Standby time for an input signal: reaction time, control box remains in waiting status for t1	≤ 1
t2	Initialisation standby time: check time following the main power start-up	3.5
t2l	Checks extraneous light during t2: waiting mode for t2l, then lockout: the motor does not start	25
t3	Pre-purge time: the fan motor is working	15
t3l	Checks extraneous light during pre-purging: control box goes into lockout at the end of t3l	25
t3i	Spark pre-ignition time	2
ts	Safety time	5
t4i	Total spark ignition time	10
t4l	Reaction time to achieve safety shut-down due to flame failure	≤ 1
t5i	Spark post-ignition time	3
tr	Re-cycles: Max. no. 3 repetitions of complete start-up sequence if there is a flame failure during operation; the final action at the last attempt following flame failure is a lock-out	3 re-cycles
tpp	Post-purge time: additional purge time at the end of a heat request. Can be interrupted by a new heat request	60

8.4.2 Presence of Extraneous light or Flame

On burner start up, when the fan starts to pre-purge the burner/boiler, if an extraneous light or flame is detected in the combustion chamber by the UV sensor the burner fan continues to run until either:

- The extraneous light or flame disappears, or
- 25 seconds elapses, a burner lockout occurs and the fault indicator LED flashes Green/Red

If an extraneous light or flame is detected after the fan has started (i.e. at some time during the pre-purge period) the pre-purge time of 15 seconds is reset, and the 25 second time for checking for the presence of extraneous light or flame starts and the fan continues to run.

As above, if the extraneous light or flame does not disappear after 25 seconds a burner lockout occurs. This function is cumulative and can operate a maximum of two times during the burner pre-purge period.

If the extraneous light or flame disappears after 24 seconds (or less) the pre-purge period and the 25 second countdown for checking for extraneous light or flame re-starts. If the extraneous light or flame re-appears the process is repeated. If the extraneous light or flame appears for a third time, the burner goes into lockout.

If during a burner recycle operation due to Flame failure (refer to Section 8.4.4 – Burner Recycle Function) an extraneous light or flame is detected, the 25 second countdown starts for checking for extraneous light or flame.

The presence of extraneous light or flame can also be detected when the burner is in:

- The standby condition waiting for a heating demand to start the burner.
- The Initialisation period (t2) after the heating demand but before the burner fan starts.

8.4.3 Spark Ignition Duration

The 'pre-ignition' spark time starts 2 seconds before the oil valve opens (the start of the 5 second 'safety time' period).

The 'post-ignition' spark time ends 3 seconds after the end of the safety time period, i.e. 8 seconds after the oil valve opens.

The ignition spark is present throughout the 'safety time' period (5 seconds) making a total spark ignition period of 10 seconds.



NOTE

In the case of continuous ignition sequence recycling after flame failure, or heat demands close to one another, the maximum number of cycle repetitions of the ignition transformer is one attempt every minute.

8.4.4 Burner Recycle Function

In event of flame failure during burner operation the control box will allow the burner to recycle and repeat the start-up sequence for the burner to attempt to re-fire. This can occur up to a total of three attempts to re-fire the burner. If it fails a fourth time in operation it will cause a burner lockout and the reset push-button indicator LED will be RED.



NOTE

After 8½ minutes of continuous burner operation the control box regains one attempt to re-fire (should it be required). If the power supply to the boiler is disconnected and then reconnected, when the next heat demand is applied to the burner all three possible attempts to re-fire are restored.

8.4.5 Post Purge Function

This function allows air flow through the burner for a pre-set time after the burner flame is switched off (on the loss of demand for the burner to fire).

The loss of demand from either the heating system controls, or boiler temperature control, interrupts the switched live to the burner resulting in the fuel supply being shut off and the flame stopped.

The permanent supply to the burner maintains the fan operation for a short period to provide the post purging of the burner and boiler prior to the burner re-firing again.

The post-purge function does not operate:

- After a burner lockout has occurred
 - If the heat demand is interrupted during the pre-purge period
- However, the post-purge function will operate if the heat demand is interrupted:
- During the safety time period (i.e. immediately after burner ignition)
 - During normal operation of the burner

If the UV cell detects any extraneous light or flame during the pre-purge period the burner will go to 'lockout' after 25 seconds.

If there is a new heat demand during the post-purge period, the post-purge function is halted (the fan stops) and a new burner operating cycle starts.

9 Fault Finding

9.1 Burner Fault Indication

Whenever a burner lockout occurs the cause is displayed via the reset push button indicator LED on the control box. The colour, sequence and speed of the indicator LED flashes identify the specific lockout type and the possible causes are listed in Table 8-1.

Table 9-1: Burner fault indication

Lockout description	Lockout time	LED colour	Probable cause
Presence of extraneous light during standby	After 25 seconds	RED blinking	<ul style="list-style-type: none"> • Presence of a false flame signal before the heat request
Presence of extraneous light detected during pre-purging	After 25 seconds	RED blinking	<ul style="list-style-type: none"> • Presence of false flame signal during pre-purging
Extraneous light detected during post-purging	After 25 seconds	RED blinking	<ul style="list-style-type: none"> • Presence of false flame signal during post-purging (or pre-heating if the short-circuit socket is not connected)
The flame is not detected after the safety time	After 5 seconds from oil-valve starts	RED steady ON	<ul style="list-style-type: none"> • UV sensor defective or dirty • Oil valve defective or dirty • Faulty ignition transformer • Badly regulated burner • Oil fuel not present
Flame failure during operation	After 3 recycles	RED blinking	<ul style="list-style-type: none"> • Badly adjusted burner • Oil valve defective or dirty • UV sensor defective or dirty
Fan motor error	Immediate (during pre-purge)	RED, ORANGE blinking inverted	<ul style="list-style-type: none"> • Faulty fan motor • Fan motor not connected
Malfunction in the internal control circuit that drives the oil valve	Immediate (during pre-purge)	RED, GREEN blinking inverted	<ul style="list-style-type: none"> • Faulty oil valve • Internal control circuit that drives the oil valve faulty
Eeprom error	Immediate (during pre-purge)	ORANGE, GREEN blinking inverted	<ul style="list-style-type: none"> • Faulty internal memory

9.2 Burner Fault Diagnostics

Table 9-2: Burner faults

Faults	Possible cause	Fault diagnostics	Solutions
The burner does not start when there is heat demand	Lack of electrical supply	OFF	Check presence of voltage in the L - N the pin plug
			Check the conditions of the fuses.
			Check that safety thermostat is not in lockout
The burner goes into lockout mode before or during the pre-purging	The UV sensor sees an extraneous light	GREEN, RED blinking	Eliminate the extraneous light.
	The connections in the control box are wrongly inserted	OFF	Check and connect all the plugs and sockets properly.
The burner goes into lockout mode before or during the pre-purging	The UV sensor sees extraneous light	RED blinking	Eliminate the extraneous light.
	The UV sensor is dirty	RED steady ON	Clear it
	The UV sensor is faulty		Replace it
	Flame moves away or fails		Check pressure and output of the fuel
			Check air output
Change nozzle			
Check the coil of solenoid valve			
Burner starts with an ignition delay	The ignition electrodes are wrongly positioned	GREEN blinking	Adjust them according to the instructions of this manual
	Air output is too high		Set the air output according to the instructions of this manual
	Nozzle dirty or worn		Replace it

10 Spare Parts

10.1 Riello RDB BLU Burner Parts List

Table 10-1: Riello RDB BLU burner parts list

Key	Description	21kW burner	26kW burner	36kW burner	Riello product code	Grant UK product code
1	Gasket	✓	✓	N/A	3005787	RBS27
1	Gasket	N/A	N/A	✓	20117411	RBS200
2	4-pin connector	✓	N/A	N/A	20117417	RBS201
2	4-pin connector	N/A	✓	✓	20117432	RBS202
3	Combustion head - BG1	✓	✓	N/A	20117435	RBS203
3	Combustion head - BG3	N/A	N/A	✓	20117437	RBS204
4	Ignition electrodes	✓	✓	✓	20117455	RBS205
5	Pre-heater jumper	✓	✓	✓	20045862	RBS206
6	Nozzle holder	✓	✓	N/A	20117459	RBS207
6	Nozzle holder	N/A	N/A	✓	20117461	RBS208
7	Collar (including o-rings)	✓	✓	N/A	20117472	RBS209
7	Collar (including o-rings)	N/A	N/A	✓	20117476	RBS210
8	Ignition HT lead	✓	✓	✓	20105111	RBS211
9	Air damper assembly	✓	N/A	N/A	3008647	RBS116
9	Air damper assembly	N/A	✓	✓	3008839	RBS166
10	Fan	✓	✓	✓	3005788	RBS151
11	UV sensor	✓	✓	✓	20095126	RBS212
12	Capacitor 4.5 μ F	✓	✓	✓	20071576	RBS149A
13	Solenoid valve	✓	✓	✓	3007871	RBS213
14	Pump pressure regulator	✓	✓	✓	20032135	RBS214
15	Air adjuster disc	✓	N/A	N/A	20094349	RBS215
16	Oil pump	✓	✓	✓	20030953	RBS101
17	O-ring (pump filter) - 10 pack	✓	✓	✓	3007175	RBS216
18	Pump filter and o-ring	✓	✓	✓	3020436	RBS217
19	Oil hose connector - 3/8 x 1/4	✓	✓	✓	3009068	RBS218
20	Flexible oil hose	✓	✓	✓	3007621	RBS219
21	Oil pipe	✓	✓	✓	20117488	RBS220
22	Pressure gauge connector	✓	✓	✓	3008876	RBS138
23	Oil pump drive coupling - 10 pack	✓	✓	✓	3000443	RBS16
24	Solenoid coil	✓	✓	✓	3008648	RBS117
25	Motor and capacitor 4.5 μ F	✓	✓	✓	20071577	RBS102A
26	Control box cover	✓	✓	✓	20094351	RBS221
27	Control box	✓	✓	✓	20117694	RBS222
28	Solenoid coil lead	✓	✓	✓	3008682	RBS223
29	Cover	✓	✓	✓	20117497	RBS224
30	O-ring kit	✓	✓	✓	3008878	RBS140
31	Front shield	✓	✓	✓	3020306	RBS225
32	Air intake - balanced flue	✓	✓	✓	3020281	RBS226
33	Air baffle	✓	✓	N/A	20117504	RBS227
33	Air baffle	N/A	N/A	✓	20117506	RBS228
34	Flange	✓	✓	N/A	3006384	RBS119
34	Flange	N/A	N/A	✓	20094352	RBS229
35	Air intake - conventional flue	✓	✓	✓	20012046	RBS230

10.2 Exploded View of Riello RDB BLU Burner

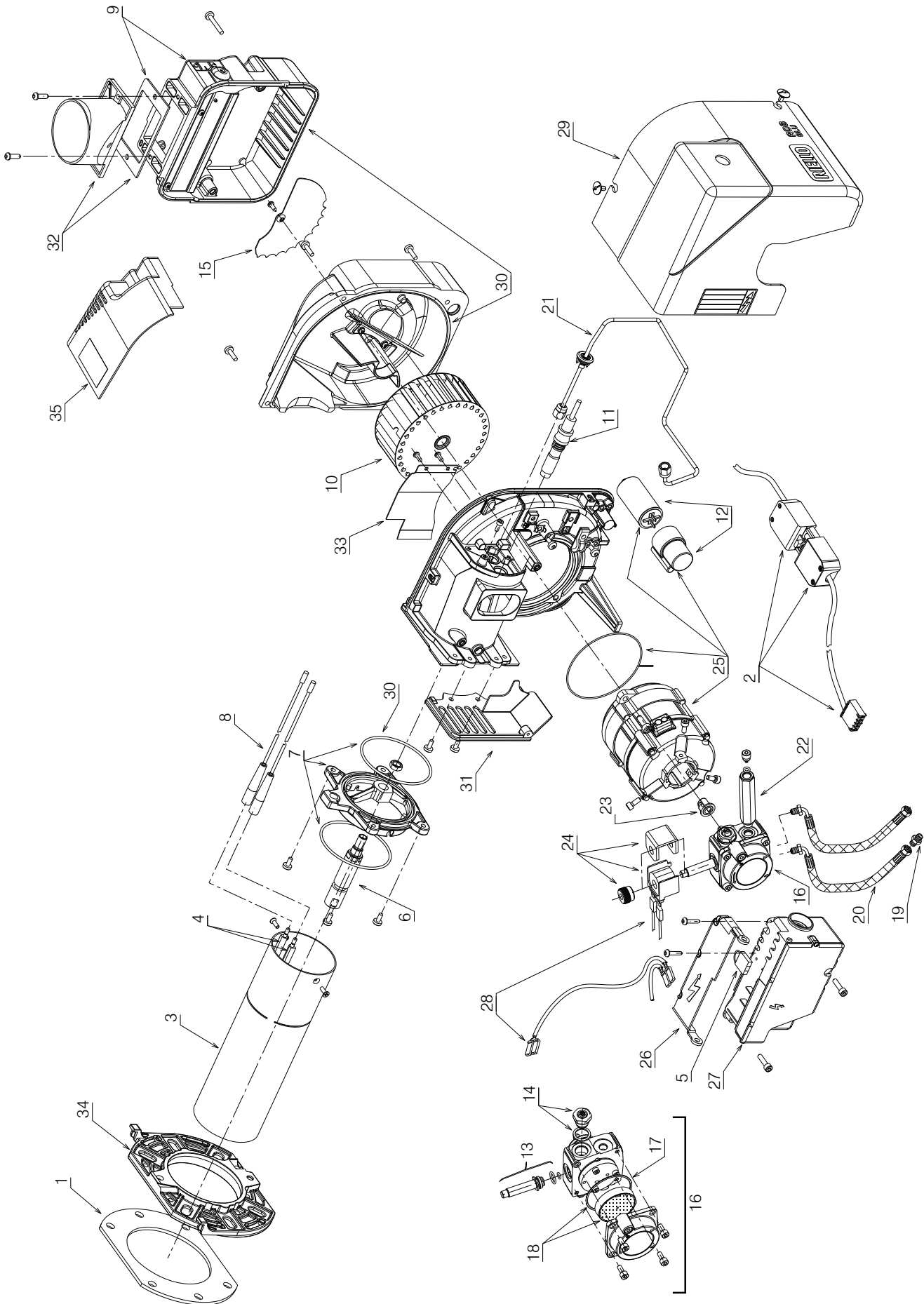

Figure 10-2: Exploded view of Riello RDB BLU burner



GRANT ENGINEERING (UK) LIMITED

Hopton House, Hopton Industrial Estate, Devizes, Wiltshire, SN10 2EU

Tel: +44 (0)1380 736920 Fax: +44 (0)1380 736991

Email: info@grantuk.com www.grantuk.com