

FM63 Cast Iron Gate Valve

Crane cast iron gate valves offer the ultimate in dependable service wherever minimum pressure drop is important. Each valve is manufactured in accordance with BS EN 1171 and hydrostatically tested to BS EN 12266-1.

Materials

ITEM NO	DESCRIPTION	MATERIAL	MATERIAL SPEC
1	Body	Grey Iron	BS EN 1561 GJL-250
2	Bonnet	Grey Iron	BS EN 1561 GJL-250
3	Disc	Grey Iron	BS EN 1561 GJL-250
4	Body Seat Ring	Bronze	BS EN 1982 (CC491K)
5	Disc Seat Ring	Bronze	BS EN 1982 (CC491K)
6	Stem	Stainless Steel	BS970: 410S21
7	Gasket	Graphite	Graphite (Asbestos Free)
8	Gland Packing Nut	Stainless Steel	BS970: 304S31
9	Handwheel	Grey Iron	BS EN 1561 EN-GJL-250
10	Stem Retaining Ring	Stainless Steel	BS970: 304S31
11	Disc Stem Nut	Bronze	BS EN 1982 (CC491K)
12	Packing Ring	Graphite	Graphite (Asbestos Free)
13	Body/Bonnet Bolt	Steel	BS 3692 GR 8.8
14	Body/Bonnet Nut	Steel	BS 3692 GR 8
15	Handwheel Retaining Nut	Steel	BS 4190 GR 4
16	Handwheel Washer	Steel	BS4320
17	Body I.D. Plate (Not Shown)	Aluminium	-



Dimensions and Weights

SIZE (mm)	A (mm)	B (mm)	C (mm)	D (mm)	E (mm)	F (mm)	WEIGHT (kg)
65	190	20	185	262	190	118	18.7
80	203	22	200	286	190	132	23.9
100	229	24	220	356	220	156	37.6
125	254	26	250	426	300	184	50.7
150	267	26	285	463	300	211	63.8
200	292	30	340	578	350	266	104.3

All dimensions are nominal.

Please note sizes 50, 250 and 300mm are also available, please refer to the website.

Dimensional Drawing

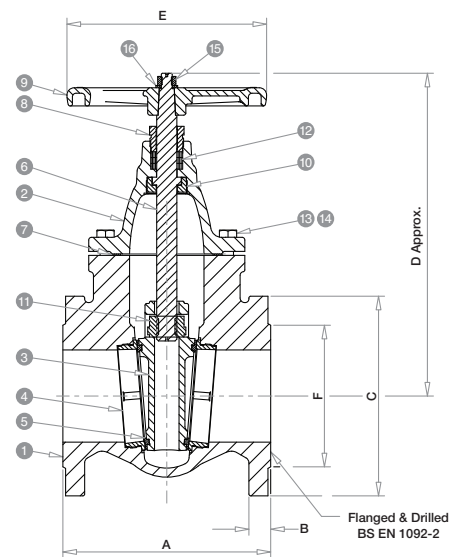

PRESSURE RATING: PN16

UK END CONNECTION: Flanged to BSEN 1092-2

PRESSURE/ TEMPERATURE OPERATING RANGE:
-10 to 120°C at 16 bar, 200°C at 12.8 bar

AVAILABLE OPTIONS: Flanges undrilled, P50 Locking device, P139 Stem Adapter.

SPECIFICATION: Wedge Disk, Non-Rising Stem, Inside Screw, Handwheel Operated. This valve is not suitable for use on group 1 gasses or unstable fluids, as defined by the Pressure Equipment Directive 97/23/EC.

CRANE FLUID SYSTEMS

CRANE HOUSE
EPSILON TERRACE,
WEST ROAD, IPSWICH
SUFFOLK IP3 9FJ

TELEPHONE: +44 (0) 1473 277 300
FAX: +44 (0) 1473 277 301
EMAIL: enquiries@cranefs.com
www.cranefs.com

The Company reserve the right to amend any product without notice.

CFS_FM63_04_2010