

Polaris Spectra Tool Kit Guide

Revision 1
June 2006

IMPORTANT
Please read this entire document
before attempting to operate
Polaris Spectra tools

Revision Status

Revision Number	Date	Description
1	June 2006	Initial release

Part Number: IL-1070131

Copyright 2006 Northern Digital Inc. All Rights Reserved.

🍁 Printed in Canada.

Published by:

Northern Digital Inc.
103 Randall Dr.
Waterloo, Ontario, Canada N2V 1C5

Telephone: + (519) 884-5142
Toll Free: + (877) 634-6340
Global: + (800) 634 634 00
Facsimile: + (519) 884-5184
Website: www.ndigital.com

Copyright 2006, Northern Digital Inc.

All rights reserved. No part of this document may be reproduced, transcribed, transmitted, distributed, modified, merged or translated into any language in any form by any means - graphic, electronic, or mechanical, including but not limited to photocopying, recording, taping or information storage and retrieval systems - without the prior written consent of Northern Digital Inc. Certain copying of the software included herein is unlawful. Refer to your software license agreement for information respecting permitted copying.

DISCLAIMER OF WARRANTIES AND LIMITATION OF LIABILITIES

Northern Digital Inc. has taken due care in preparing this document and the programs and data on the electronic media accompanying this document including research, development, and testing.

This document describes the state of Northern Digital Inc.'s knowledge respecting the subject matter herein at the time of its publication, and may not reflect its state of knowledge at all times in the future. Northern Digital Inc. has carefully reviewed this document for technical accuracy. If errors are suspected, the user should consult with Northern Digital Inc. prior to proceeding. Northern Digital Inc. makes no expressed or implied warranty of any kind with regard to this document or the programs and data on the electronic media accompanying this document.

Northern Digital Inc. makes no representation, condition or warranty to the user or any other party with respect to the adequacy of this document or accompanying media for any particular purpose or with respect to its adequacy to produce a particular result. The user's right to recover damages caused by fault or negligence on the part of Northern Digital Inc. shall be limited to the amount paid by the user to Northern Digital Inc. for the provision of this document. In no event shall Northern Digital Inc. be liable for special, collateral, incidental, direct, indirect or consequential damages, losses, costs, charges, claims, demands, or claim for lost profits, data, fees or expenses of any nature or kind.

Product names listed are trademarks of their respective manufacturers. Company names listed are trademarks or trade names of their respective companies.



Table of Contents

Read Me First!	ii
Warnings	ii
Disclaimers	ii
Contact Information	iii
Updates	iii
1 Introduction	1
1.1 Tool Definition Files	1
1.2 Polaris Spectra Passive Tools	1
1.3 Passive Sphere Markers	2
2 Tools Specifications	5
2.1 Rigid Body - Part Number 8700339	6
2.2 Rigid Body - Part Number 8700449	7
2.3 Probe - Part Number 8700340	8
3 Tool Clamps	11
3.1 Introduction	11
3.2 Clamp Attachment	11
3.3 Rigid Body Attachment	11

Read Me First!

This guide provides information about passive tools provided for use with the Polaris[®] Spectra[™] Optical Tracking System. Read this section before continuing with the rest of the guide.

Warnings



In all NDI documentation, warnings are marked by this symbol. Follow the information in the accompanying paragraph to avoid personal injury.

1. Do not incorporate non-NDI components with the Polaris Spectra System. The accuracy of results produced by applications that incorporate non-NDI components with the Polaris Spectra System are unknown. Reliance on data provided by non-NDI components may lead to inaccurate conclusions and may cause personal injury.

Disclaimers

1. NDI tools and clamps are not approved for medical use. Testing, certification and validation should be completed prior to use in any medical application. Please contact NDI for details.
2. Read the entire “*Polaris Spectra User Guide*” before attempting to operate the Polaris Spectra System.
3. The user must determine the suitability of the Polaris Spectra System, tools and clamps for their own application.

Contact Information

If you have any questions regarding the content of this guide or the operation of the Polaris Spectra System or tools, please contact us:



**INTERNATIONAL HEADQUARTERS:
NORTHERN DIGITAL INC.**

103 Randall Drive
Waterloo, ON, Canada N2V 1C5

Phone: + 1 (519) 884-5142
Toll Free: + 1 (877) 634-6340
Global: + (800) 634-6340
Fax: + 1 (519) 884-5184

Email: support@ndigital.com
Website: www.ndigital.com

EUROPEAN OFFICE:

NDI EUROPE GmbH
Fritz-Reichle-Ring 2
D-78315 Radolfzell
Germany

Phone: + 49 (77 32) 939 19 00
Global: + (800) 634 634 00
Fax: + 49 (77 32) 939 19 09

Email: support@ndieurope.com
Website: www.ndieurope.com

ASIA PACIFIC OFFICE:

NDI ASIA PACIFIC
Room 2603, 26th Floor
Office Tower, Convention Plaza
1 Harbour Road
Wanchai, Hong Kong

Phone: + (852) 2802 2205
Fax: + (852) 2802 0060

Email: APsupport@ndigital.com
Website: www.ndigital.com

Updates

NDI is committed to continuous improvements in the quality and versatility of its software and hardware. To obtain the best results with your NDI system, check the NDI Support Site regularly for update information:

<http://support.ndigital.com>

1 Introduction

The Polaris Spectra Tool Kit includes:

- 25 passive sphere markers
- two single-faced rigid bodies (part number 8700339 and part number 8700449)
- a probe
- a small clamp for mounting the rigid bodies to cylindrical components with a diameter of 2 mm - 8 mm
- a large clamp for mounting the rigid bodies to cylindrical components with a diameter of 8 mm - 16 mm
- a 2 mm Allen key for attaching the rigid bodies
- a 4 mm Allen key for attaching the clamps
- Polaris Spectra Tool Kit guide
- a CD containing a tool definition file (.rom) for each tool

This guide outlines the specifications and the usage instructions for each component in the kit. Information on the use of the Polaris Spectra System is detailed in the “*Polaris Spectra User Guide*.” You must familiarize yourself with the system before attempting to use any of the tools.

Polaris tools and tool design are both described in greater detail in the “*Polaris Tool Design Guide*.”

1.1 Tool Definition Files

Each tool in the kit has a tool definition file associated with it. The tool definition file is contained on the CD that accompanies the tool kit. Each tool definition file is identified by tool part number and a .rom extension. For example, the tool definition file for the larger rigid body is 8700449.rom.

Tool definition files are also available on the Polaris Spectra CD and the NDI support site.

1.2 Polaris Spectra Passive Tools

Polaris Spectra passive tools are rigid bodies (structures) that incorporate a minimum of three fixed markers with no relative movement between them. The Polaris Spectra System determines and tracks the positions and orientations of the tools. The rigid bodies and probe in the Polaris Spectra Tool Kit are examples of different tools.

Unique Geometry

Each Polaris Spectra tool has an asymmetrical marker geometry, in which the combination of distances and angles between markers is unique.

Unique geometry is necessary to identify wireless tools. If there are several tools in the characterized measurement volume, the system has to determine which markers belong to which tool. All the tools in the tool kit have unique geometry and can therefore be tracked simultaneously.

The system cannot track two identical tools simultaneously.

1.3 Passive Sphere Markers

Polaris Spectra passive tools utilize passive sphere markers coated with a retro-reflective material. The markers (or spheres) are designed to snap fit onto corresponding mounting posts, as shown in [Figure 1-1](#). Passive tools incorporate a minimum of three and a maximum of six markers.

The marker is fitted to the mounting post by placing the marker on the mounting post and pressing down until a snap occurs.

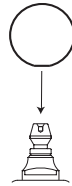

Figure 1-1 Passive Sphere and Standard Mounting Post

Adverse handling of the markers, such as dropping or scuffing will affect their reflectivity. Markers should also be handled with finger cots or gloves, as skin oils diminish reflectivity. There is no easy way to test how well a marker is reflecting; however, poor tracking or accuracy of a tool may be an indication of “dirty” markers. Replacing the markers with new ones is a quick way to test this hypothesis.

Sterilization

Passive sphere markers may be supplied either sterile or non-sterile. Sterile markers are supplied in sealed pouches and are single use only.

Testing has shown that there is no significant degradation in the performance of the markers after they have been sterilized once (with an appropriate cycle) using the ETO, STERRAD 100S or STERIS SYSTEM 1 methods of sterilization.

Do not autoclave markers as this may destroy the markers physical integrity. NDI recommends that the un-sterilized markers be sterilized only once, as multiple cycles of sterilization and cleaning may adversely affect the marker’s performance.

Contact NDI for more information on marker sterilization.

Cytotoxicity

Contact NDI for more information on marker cytotoxicity.

Isotropic Behaviour

Contact NDI for more information on the isotropic behaviour of markers. See the “*Polaris Tool Design Guide*” for further details.

Mounting Posts

NDI supplies two types of mounting post; standard (NDI part number 1201101) and enhanced (NDI part number 1201136). The standard mounting post is designed for use under normal environmental shock conditions and the enhanced mounting post is designed for use under extreme environmental shock conditions. An example of extreme environmental shock conditions would be the shocks delivered during orthopedic procedures. The specifications for both mounting posts are shown below.

Standard Mounting Post

The standard mounting post is designed so that the centre of a marker, when correctly fitted, is located at the centre of the top of the mounting post. The standard mounting post specifications are shown in [Figure 1-2](#). You can determine the top of the centre of the standard mounting post with a digitizing probe equipped with a 1 mm diameter ball tip.

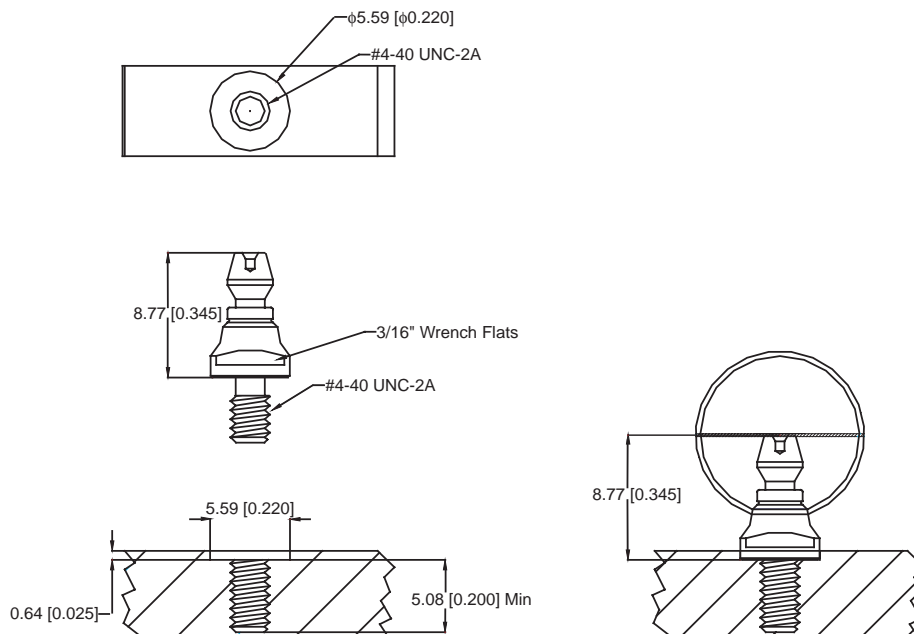

NOTE:
 1. PRIMARY UNITS IN MM.
 2. SECONDARY UNITS IN INCHES.

Figure 1-2 Standard Mounting Post Specifications

Enhanced Mounting Post

The enhanced mounting post differs from the standard mounting post only in the amount that the post is inserted into the passive sphere. On the enhanced mounting post, the post also contacts the upper half of the sphere, thereby improving its security. The enhanced mounting post specifications are shown in [Figure 1-3](#).

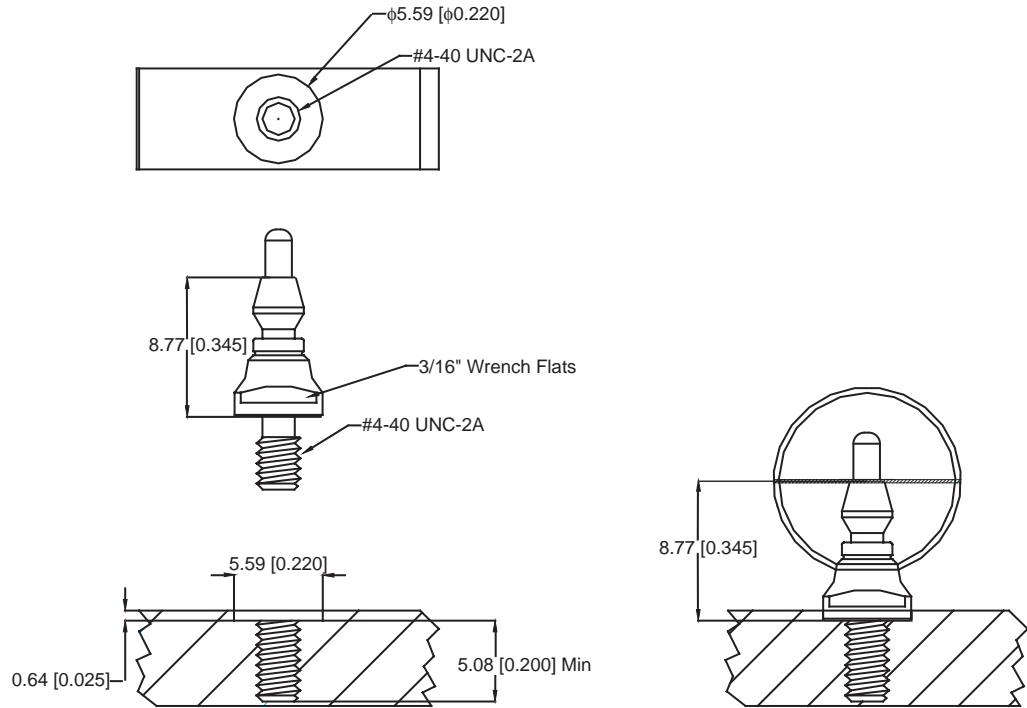

NOTE:
1. PRIMARY UNITS IN MM.
2. SECONDARY UNITS IN INCHES.

Figure 1-3 Enhanced Mounting Post Specifications

2 Tools Specifications

This chapter contains specifications on the Spectra tools contained in this kit. The tools are supplied with standard mounting posts (NDI part number 1201101). Enhanced mounting posts (NDI part number 1201136) can be ordered from NDI.

2.1 Rigid Body - Part Number 8700339

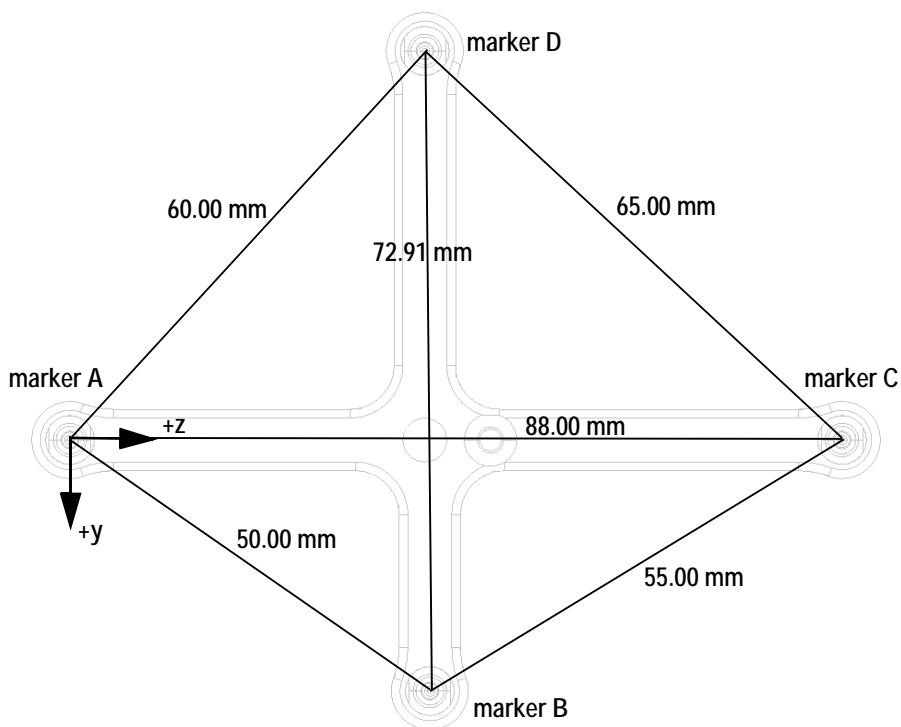
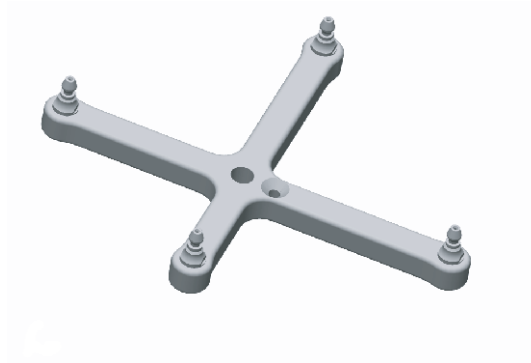

Specifications

Geometry	x (mm)	y (mm)	z (mm)
Marker A	0.00	0.00	0.00
Marker B	0.00	28.59	41.02
Marker C	0.00	0.00	88.00
Marker D	0.00	-44.32	40.45

Note The above coordinates are referenced to the centre of the spheres.

2.2 Rigid Body - Part Number 8700449

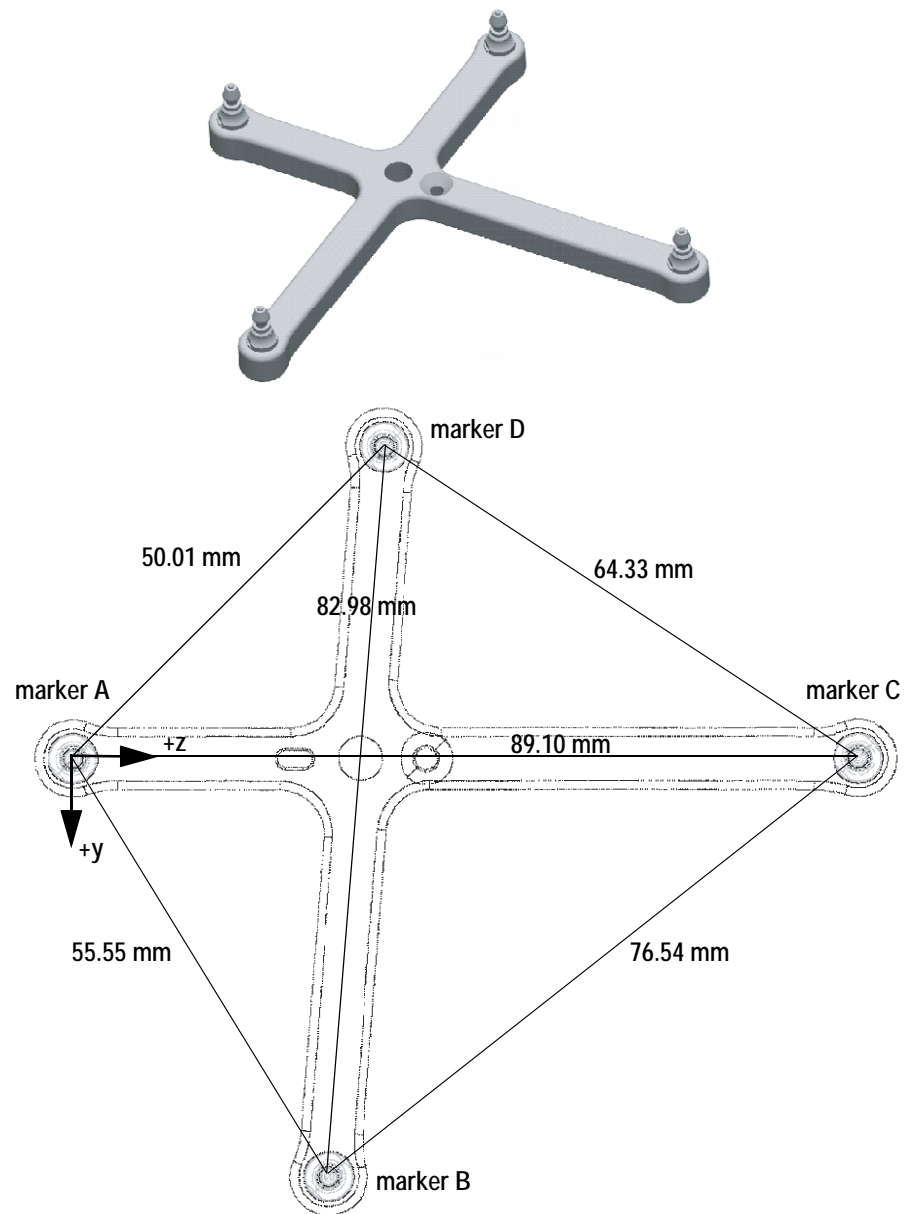

Specifications

Geometry	x (mm)	y (mm)	z (mm)
Marker A	0.00	0.00	0.00
Marker B	0.00	47.38	28.99
Marker C	0.00	0.00	89.10
Marker D	0.00	-35.36	35.36

Note The above coordinates are referenced to the centre of the spheres.

2.3 Probe - Part Number 8700340

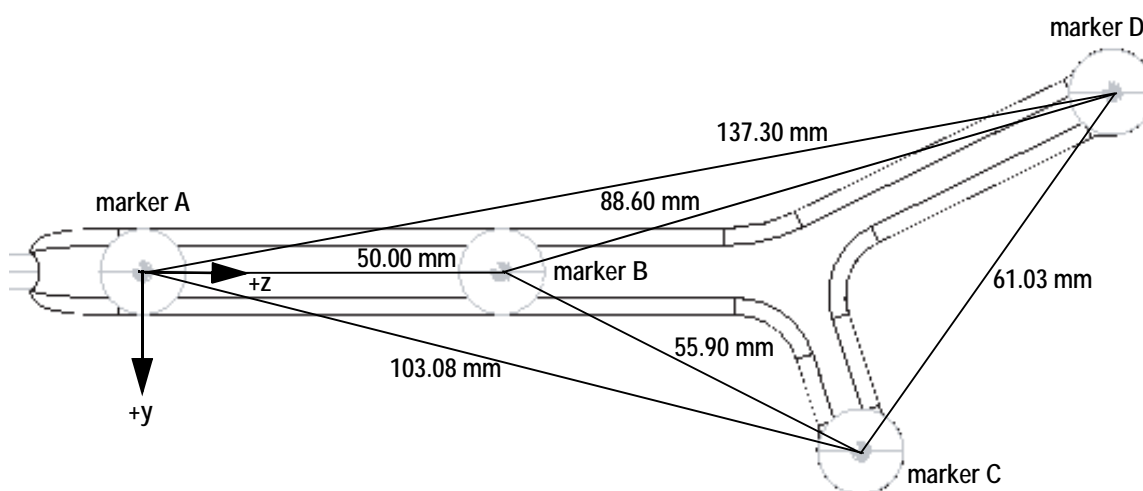
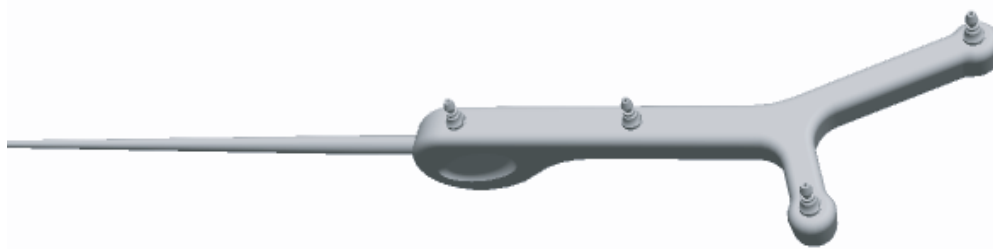

Specifications

Geometry	x (mm)	y (mm)	z (mm)
Marker A	0.00	0.00	0.00
Marker B	0.00	0.00	50.00
Marker C	0.00	25.00	100.00
Marker D	0.00	-25.00	135.00

Note The above coordinates are referenced to the centre of the spheres.

Pivoting

Pivoting is the procedure used to determine the tip offset of a probe type tool; that is, the distance between the tool origin and its tip.

Why Pivot?

There may be applications in which the position of the tool tip needs to be reported. If the tool tip should become bent, then the position of the tool tip would be incorrectly reported. Pivoting the tool is a quick, accurate procedure that determines the tip offset of the tool.

NDI recommends that you pivot a probe type tool before each use.

Pivot Block Design

A pivot block should be used to ensure that the pivoting procedure is accurate and repeatable. The following points should be considered when you design a pivot block:

1. The pivot block should be manufactured with substantial mass, to reduce the possibility of movement during use.
2. A method should be provided to secure the pivot block, such that it cannot move during use.
3. The divot should match the tip:
 - The tool tip should fit the divot such that the tip does not move during pivoting. The divot should not be so wide that the tool tip moves within the divot, nor should it be so small that the tool tip tends to leave the divot.
 - Shallow divots (dents) should be provided for pivoting tools with sharp points.
4. An appropriately sized convex arrangement (ball) should be provided as part of the pivot block. This is to accommodate tools with concave tips.

How to perform a pivoting procedure

A pivoting procedure may be done in either NDI 6D Architect or NDI ToolBox applications. Application specific instructions are detailed in the appropriate application documentation.

The physical pivoting procedure is the same in all applications:

1. Make sure that the tool is within the characterized measurement volume.
2. Position the tool tip in the appropriately sized divot. The size and shape of the divot must match the tool tip to ensure that the tip does not move.
3. Make sure that all the markers are in line of sight of the Position Sensor.
4. Start the collection, as detailed in the application software.
5. Pivot the tool in a cone shape, for about 20 seconds, at an angle of 30° to 60° from the vertical, as shown in [Figure 2-1 on page 10](#).

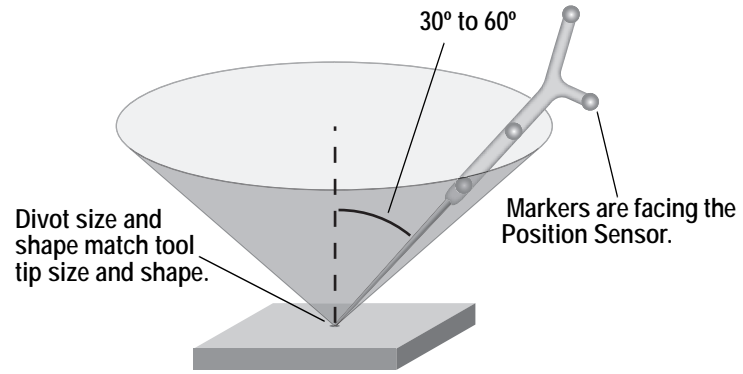

Figure 2-1 Pivoting Technique

3 Tool Clamps

3.1 Introduction

The Polaris Spectra Tool Kit includes two clamps that are designed to securely attach the rigid bodies to a cylindrical structure (for instance, a tool shaft.) The clamps are similar, the only difference is that they are designed to attach to different diameter structures as follows:

- small clamp (Part No. 8700414) 2 mm to 8 mm diameter
- large clamp (Part No. 8700413) 8 mm to 16 mm diameter

The clamp is attached to the cylindrical structure by means of hinged jaws. It is secured with a single screw that causes a plate to bear down on the jaws. The jaws are hinged in such a way that the plate causes the jaws to tighten around the cylindrical structure, thus tightening the clamp.

The rigid body is attached to the clamp at one of two positions, top or side. The method of attachment is identical in both cases. The clamp incorporates a steel pin that locates the rigid body. The rigid body is then secured by means of a single screw.

3.2 Clamp Attachment

Attach the clamp to the cylindrical structure as follows:

Note A 4 mm Allen key is required to attach the clamp to the cylindrical structure.

1. Select the correct size clamp for the structure:
 - small clamp (Part No. 8700414) 2 mm to 8 mm diameter
 - large clamp (Part No. 8700413) 8 mm to 16 mm diameter
2. Loosen the screw to allow the clamp jaws to open wide enough to locate over the structure.
3. Locate the clamp on the structure at the required position and orientation.
4. Secure the clamp with the single screw and tighten just sufficient to prevent the clamp from moving.

3.3 Rigid Body Attachment

Attach the rigid body to the clamp as follows:

Note A 2 mm Allen key is required to attach the rigid body to the clamp.

1. Attach the clamp to the cylindrical structure as described above.
2. Locate the rigid body on the top or side of clamp as required.

3. Secure the rigid body with the single screw and tighten just sufficient to prevent the rigid body from moving.

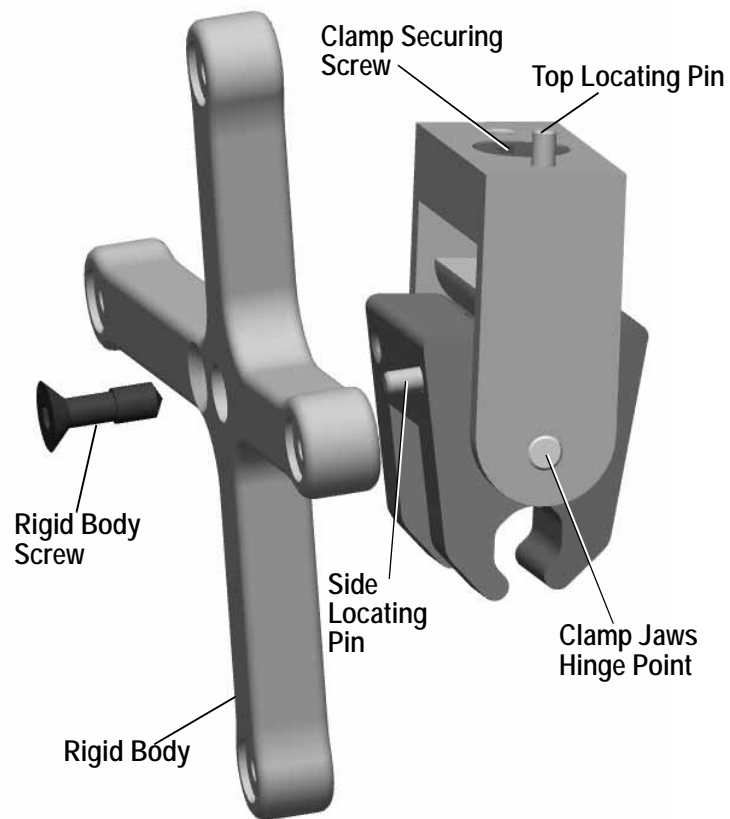

Figure 3-1 Rigid Body - Attachment to Clamp