

# Low Power Design User Guide

**GSM/GPRS Module Series**

Rev. Low\_Power\_Design\_User\_Guide\_V1.3

Date: 2015-04-11



**Our aim is to provide customers with timely and comprehensive service. For any assistance, please contact our company headquarters:**

**Quectel Wireless Solutions Co., Ltd.**

Office 501, Building 13, No.99, Tianzhou Road, Shanghai, China, 200233

Tel: +86 21 5108 6236

Mail: [info@quectel.com](mailto:info@quectel.com)

**Or our local office, for more information, please visit:**

<http://www.quectel.com/support/salesupport.aspx>

**For technical support, to report documentation errors, please visit:**

<http://www.quectel.com/support/techsupport.aspx>

Or Email: [Support@quectel.com](mailto:Support@quectel.com)

**GENERAL NOTES**

QUECTEL OFFERS THIS INFORMATION AS A SERVICE TO ITS CUSTOMERS. THE INFORMATION PROVIDED IS BASED UPON CUSTOMERS' REQUIREMENTS. QUECTEL MAKES EVERY EFFORT TO ENSURE THE QUALITY OF THE INFORMATION IT MAKES AVAILABLE. QUECTEL DOES NOT MAKE ANY WARRANTY AS TO THE INFORMATION CONTAINED HEREIN, AND DOES NOT ACCEPT ANY LIABILITY FOR ANY INJURY, LOSS OR DAMAGE OF ANY KIND INCURRED BY USE OF OR RELIANCE UPON THE INFORMATION. ALL INFORMATION SUPPLIED HEREIN IS SUBJECT TO CHANGE WITHOUT PRIOR NOTICE.

**COPYRIGHT**

THIS INFORMATION CONTAINED HERE IS PROPRIETARY TECHNICAL INFORMATION OF QUECTEL CO., LTD. TRANSMITTABLE, REPRODUCTION, DISSEMINATION AND EDITING OF THIS DOCUMENT AS WELL AS UTILIZATION OF THIS CONTENTS ARE FORBIDDEN WITHOUT PERMISSION. OFFENDERS WILL BE HELD LIABLE FOR PAYMENT OF DAMAGES. ALL RIGHTS ARE RESERVED IN THE EVENT OF A PATENT GRANT OR REGISTRATION OF A UTILITY MODEL OR DESIGN.

**Copyright © Quectel Wireless Solutions Co., Ltd. 2015. All rights reserved.**

# About the Document

## History

Revision	Date	Author	Description
1.0	2012-09-06	Layne YE	Initial
1.1	2014-02-28	Layne YE	<ol style="list-style-type: none"><li>1. Added battery test.</li><li>2. Added DC/DC convertor reference design.</li><li>3. Added power consumption of GSM module.</li><li>4. Added battery capacity assessment.</li></ol>
1.2	2014-08-28	Layne YE	<ol style="list-style-type: none"><li>1. Added energy battery pack in Table 1.</li><li>2. Added battery testing result and comparison.</li><li>3. Rectified the reference design.</li></ol>
1.3	2015-04-11	Layne YE	Added applicable modules

## Contents

About the Document.....	2
Contents.....	3
Table Index.....	4
Figure Index.....	5
<b>1 Introduction .....</b>	<b>6</b>
<b>2 Low Power Consumption Solutions .....</b>	<b>7</b>
2.1. Power Supply Solution .....	7
2.1.1. Battery Type .....	7
2.1.2. Battery Test .....	8
2.1.2.1. Continuous Current Load Test.....	8
2.1.2.2. Pulse Current Load Test.....	9
2.1.2.3. Pulse Current Load Test with Capacitor .....	11
2.1.3. Battery Comparison and Selection .....	12
2.2. Application Reference Design.....	13
2.2.1. Reference Design of Single Battery ES-341550-W.....	14
2.2.2. Reference Design of Single Battery ER34615M .....	15
2.2.3. Reference Design of Two Battery Packs .....	16
2.3. DC/DC Step Down Convertor.....	17
2.3.1. DC/DC Convertor Design.....	17
2.3.2. DC/DC Layout Guideline.....	17
2.4. Power Consumption of GSM/GPRS Module .....	18
2.5. Battery Capacity Requirement Assessment.....	20
<b>3 Measures for Reducing Power Consumption.....</b>	<b>21</b>
<b>4 AT Command for Low Power Consumption .....</b>	<b>22</b>
4.1. AT+CDETXPW TX Power Control.....	22
4.2. Example of Reducing TX Power for GPRS Data Transmission.....	23
4.3. Example of Reducing TX Power for SMS Data Transmission .....	25
<b>5 Appendix A Reference.....</b>	<b>26</b>

## Table Index

TABLE 1: COMPARISON OF BATTERY PERFORMANCE PARAMETER .....	8
TABLE 2: PULSE CURRENT TEST CONDITION AND RESULT .....	9
TABLE 3: PULSE CURRENT LOAD TEST WITH CAPACITOR .....	11
TABLE 4: REFERENCE PRICE OF BATTERY .....	13
TABLE 5: TEST CONDITION IN DIFFERENT MODE .....	18
TABLE 6: EXAMPLE OF AVERAGE POWER CONSUMPTION IN DIFFERENT MODE .....	20
TABLE 7: REFERENCE DOCUMENT .....	26

Quectel  
Confidential

## Figure Index

FIGURE 1: DISCHARGE CURVE CHART OF CONTINUOUS LOAD .....	8
FIGURE 2: THE DROP VOLTAGE OF ER34615 .....	9
FIGURE 3: THE DROP VOLTAGE OF ER34615M .....	10
FIGURE 4: THE DROP VOLTAGE OF ES-34341550-W .....	10
FIGURE 5: THE DROP VOLTAGE OF TLP-83111A/SM .....	11
FIGURE 6: THE DROP VOLTAGE OF ER34615M WITH CAPACITOR .....	12
FIGURE 7: REFERENCE DESIGN OF SINGLE BATTERY ES-341550-W .....	14
FIGURE 8: REFERENCE DESIGN OF SINGLE BATTERY ER34615M .....	15
FIGURE 9: REFERENCE DESIGN OF TWO BATTERY PACKS OF ES-341550-W .....	16
FIGURE 10: REFERENCE CIRCUIT OF TPS54331 .....	17
FIGURE 11: CURRENT CONSUMPTION OF GPRS DATA TRANSMISSION .....	19
FIGURE 12: CURRENT CONSUMPTION OF SMS TRANSMISSION .....	19

Quectel  
Confidential

# 1 Introduction

This document mainly introduces the comprehensive solution and measure for reducing power consumption of GSM/GPRS module in lower power application, including the battery selection and relative reference design.

This document is applicable to all Quectel GSM modules.

Quectel  
Confidential

## 2 Low Power Consumption Solutions

This solution is only applied for wireless data transmission terminals which can meet the following requirements:

- Lithium-thionyl chloride (Li-SOCl<sub>2</sub>) is used for main power of the system
- The battery is a non-rechargeable battery and its lifecycle is up to one year or much longer
- Wireless data transmission terminals with less work time in application.

### 2.1. Power Supply Solution

Terminal device has to operate for a long time without AC mains supply. Hence device system needs super capacity batteries to supply power. The power supply range of the GSM/GPRS module is 3.3~4.6V, and the power for MCU is 3.3V or lower voltage. Since the battery is used as power source for device, battery capacity selection and power circuit design play an important role in reducing power consumption of whole system.

#### 2.1.1. Battery Type

Considering the long-term effective working of the battery, super capacity Lithium-thionyl chloride (Li-SOCl<sub>2</sub>) is needed. Lithium-thionyl chloride (Li-SOCl<sub>2</sub>) can not only provide the maximum energy ratio and voltage, but also have preferable discharge characteristic and little self-discharge.

Generally, super capacity Lithium-thionyl chloride (Li-SOCl<sub>2</sub>) can be classified into power type and energy type. For energy type battery, its capacity is high (e.g. ER34615 3.6V/19Ah), but maximum continuous discharge current is quite lower. And power type battery can output larger current (e.g. ER34615M 3.6V/13Ah). Besides these two typical batteries, there is another battery pack (e.g. ES-341550-W 3.6V/19Ah) which is composed of an energy battery ER34615 and a super pulse capacitor SPC1550. This battery pack can overcome the defect of energy type that cannot provide high pulse current.

The comparison of the related parameters between these three types is shown as below:



**Table 1: Comparison of Battery Performance Parameter**

Performance Parameter	Power Type (ER34615M)	Energy Type (ER34615)	Energy Battery Pack (ES-341550-W)
Nominal Capacity	13Ah @5mA,to 2V	19Ah @2mA,to 2V	19Ah @2mA,to 2V
Nominal Voltage	3.6V	3.6V	3.6V
Maximum Continuous Discharge Current	2000mA	230mA	
Maximum Pulse Current	4000mA @0.1s	400mA @0.1s	3000mA @1s
Temperature Range	-60°C ~ +85°C	-60°C ~ +85°C	-40°C ~ +85°C

**NOTES**

1. You can get more information of battery from EVE: <http://www.evebattery.com/en2/index02.aspx>.
2. There is another special battery pack from Israel. The part type is Trdiran TLP-83111/A/SM (3.9V/16Ah) that consists of a power type battery TL6930 and a super capacitor HLC-1550A.

**2.1.2. Battery Test**

**2.1.2.1. Continuous Current Load Test**

The battery ER34615, ER34615M, ES-341550-W and TLP-83111A/SM are tested in different continuous current load, the voltage drops much with the current increasing.

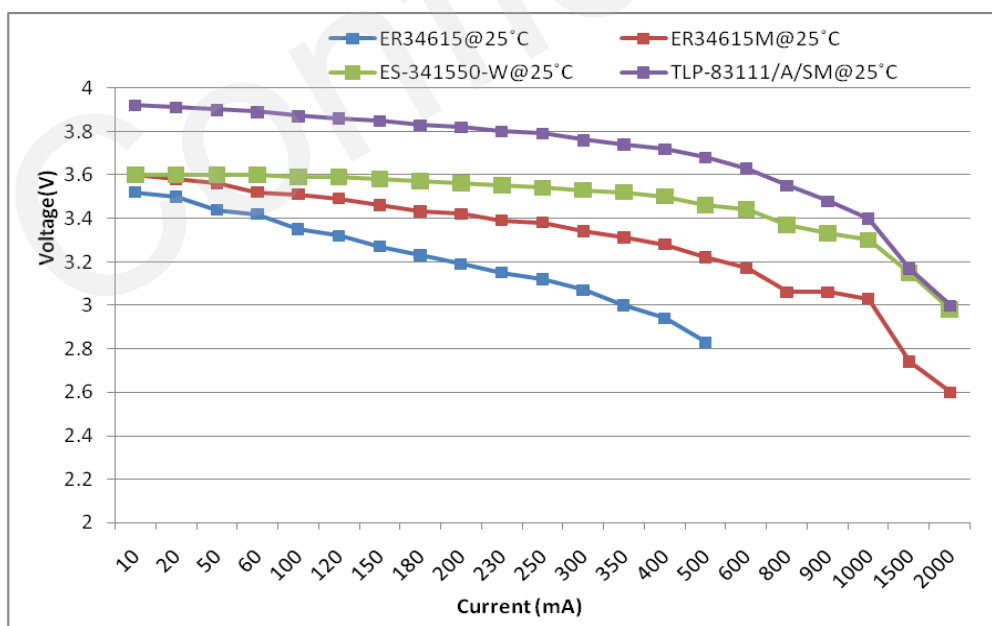

**Figure 1: Discharge Curve Chart of Continuous Load**

From the above discharge curve chart, we can see that the voltage of battery ER34615 drops to lower than 3.2V when the current load is up to 230mA, so this type cannot provide sufficient current for GSM/GPRS module. And the power type battery ER34615M can support higher current than the energy type battery ER34615. As to other two battery packs, their super capacitor can afford much higher current load that can maintain high voltage on high current load.

### 2.1.2.2. Pulse Current Load Test

The battery ER34615, ER34615M, ES-341550-W and TLP-83111A/SM are tested in pulse current load that simulates burst time cycle of GSM transmitting. The test result is shown in following table.

**Table 2: Pulse Current Test Condition and Result**

Battery Type	Pulse Current Setting	Average Current	Max. Voltage	Min. Voltage	Drop Voltage Waveform
ER34615		333mA	3.25V	1.14V	FIGURE 2
ER34615M	150mA/4.037ms	333mA	3.44V	2.91V	FIGURE 3
ES-341550-W	1800mA/0.577ms	333mA	3.56V	3.32V	FIGURE 4
TLP-83111A/SM		333mA	3.84V	3.63V	FIGURE 5

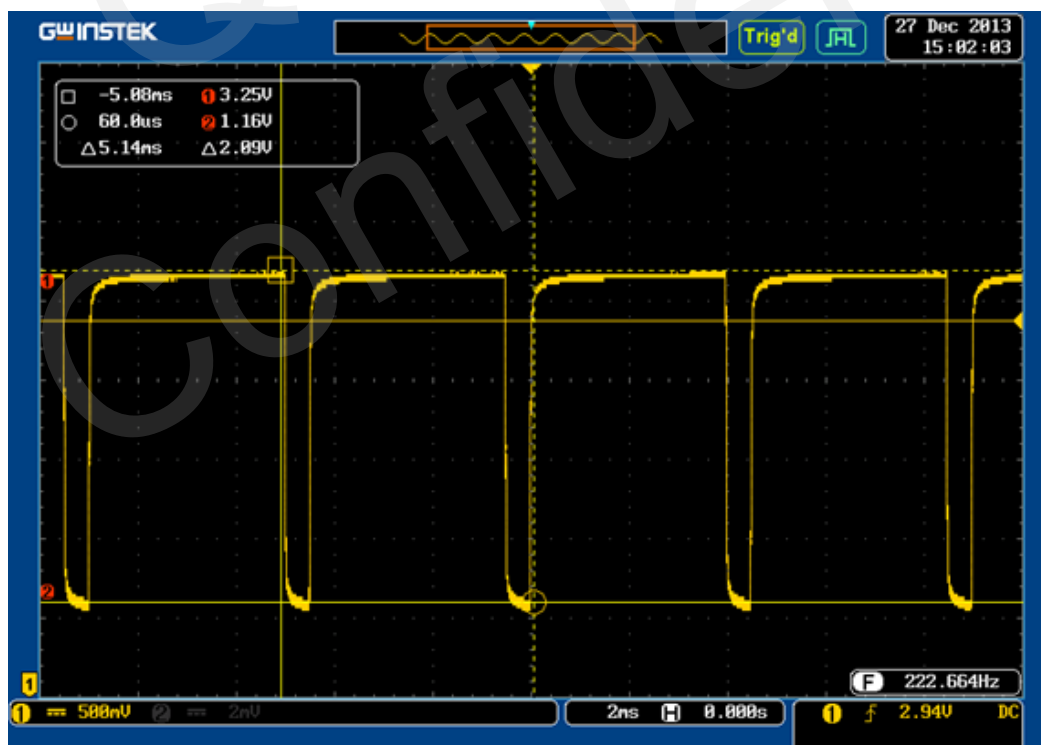

**Figure 2: The Drop Voltage of ER34615**

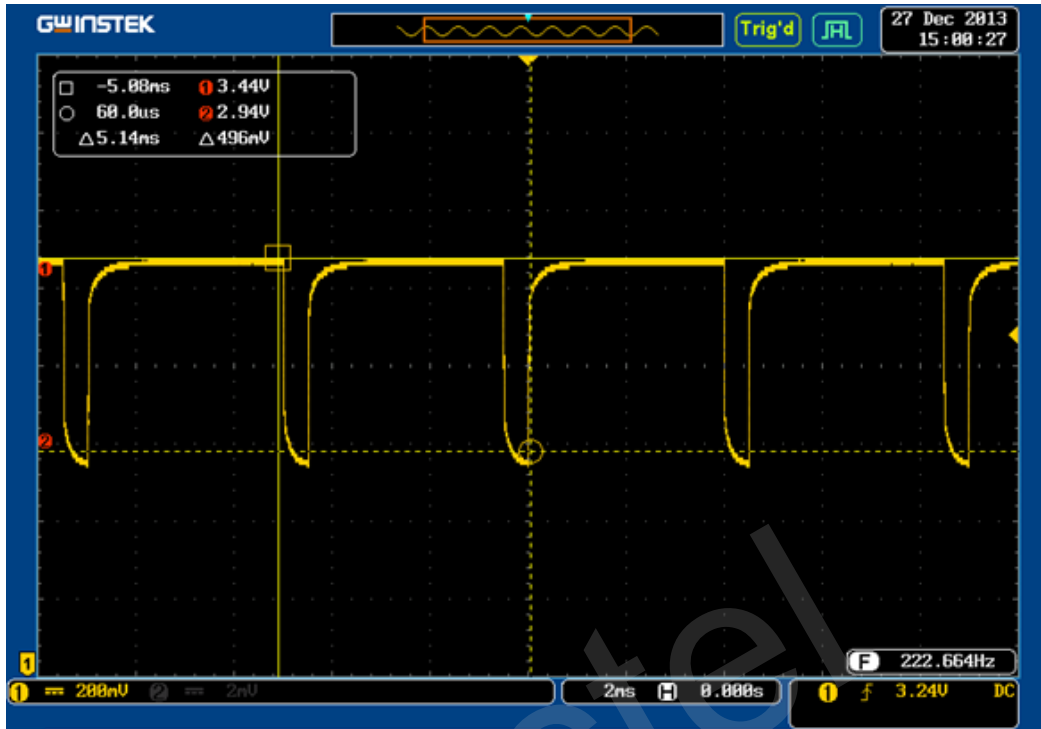

Figure 3: The Drop Voltage of ER34615M

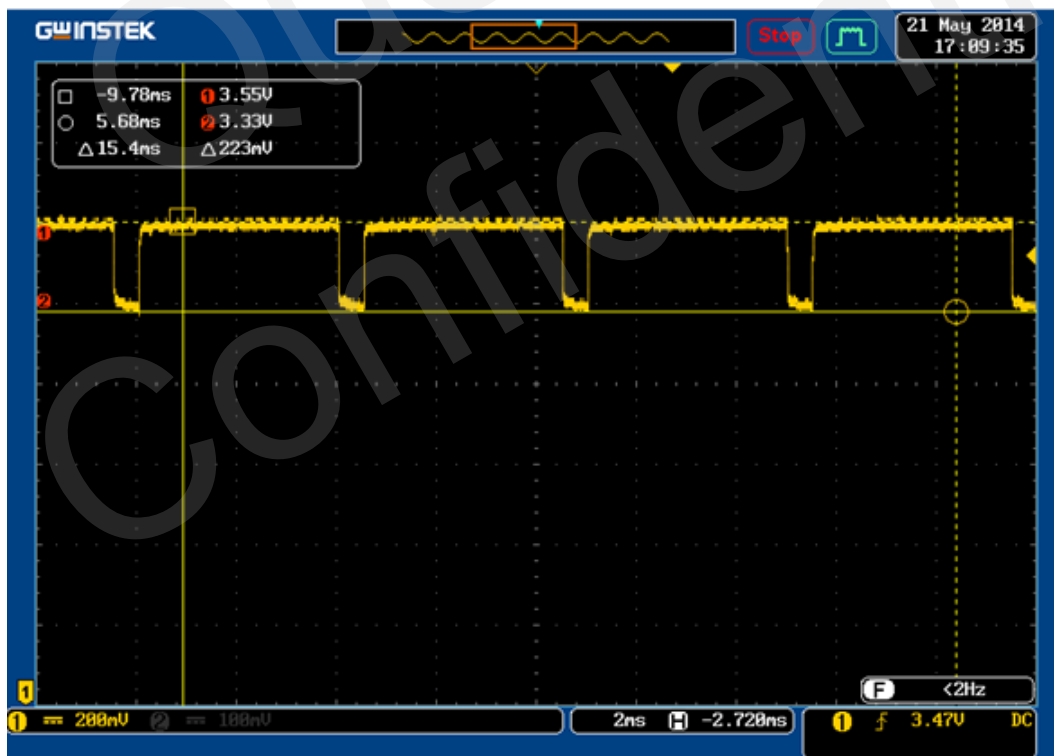

Figure 4: The Drop Voltage of ES-34341550-W

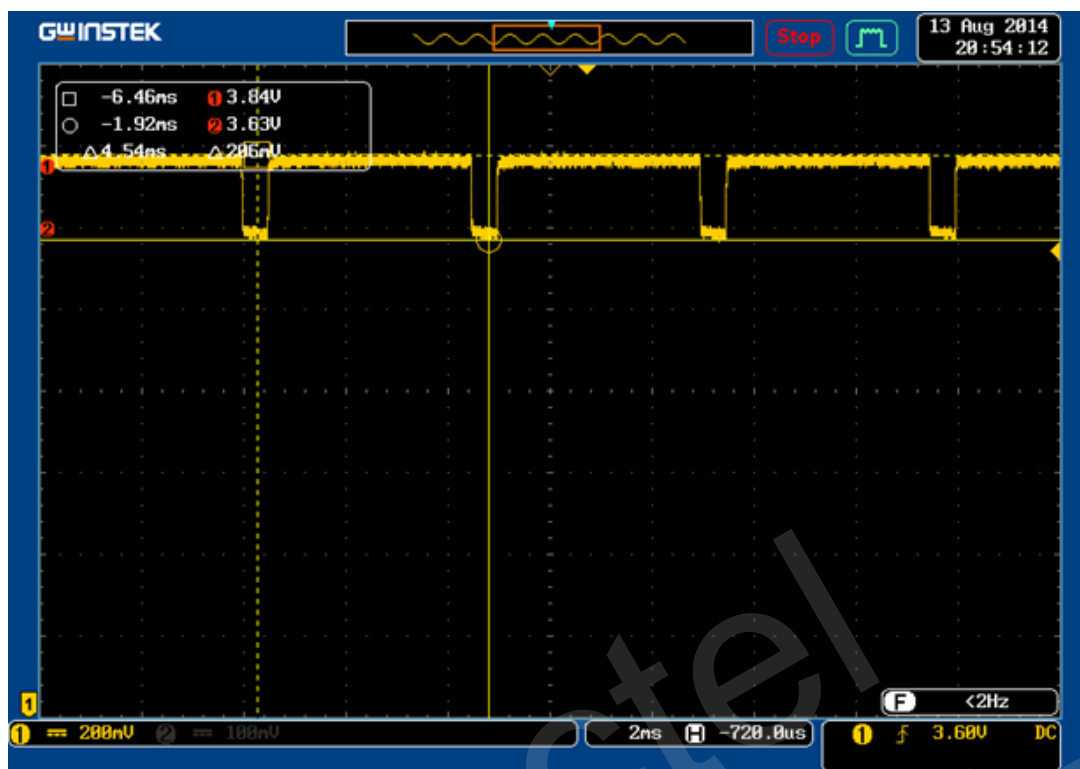

Figure 5: The Drop Voltage of TLP-83111A/SM

From the above pulse testing result, we know that voltage of ER34615 battery drops so much and the max voltage is only 3.25V which cannot satisfy the power requirements for GSM module, so the ER34615 is not suitable for GSM/GPRS module application. The battery ES-34341550-W and TLP-83111A/SM are suitable for the GSM/GPRS module application, because the voltage drops less and can be sustained higher than 3.3V when the peak current occurs.

### 2.1.2.3. Pulse Current Load Test with Capacitor

In circuit design, the battery with high capacitance capacitor (4400uF) in parallel is used as power supply for device system. The pulse current setting is same as above testing, the following table and figure show the result of voltage drops of ER34615M with 4400uF capacitor.

Table 3: Pulse Current Load Test with Capacitor

Battery Type	Pulse Current Setting	Average Current	Max. Voltage	Min. Voltage	Drop Voltage Waveform
ER34615M+4400uF	150mA/4.037ms 1800mA/0.577ms	333mA	3.46V	3.26V	FIGURE 6

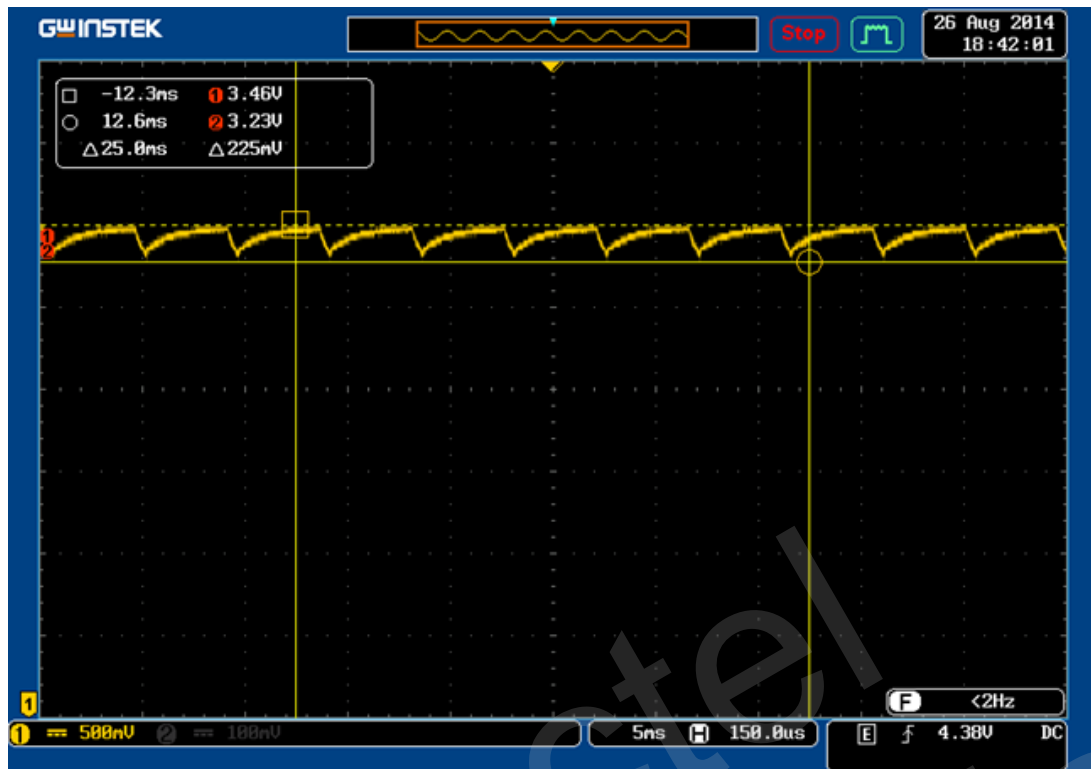

**Figure 6: The Drop Voltage of ER34615M with Capacitor**

Compared to the voltage waveform in figure 3, the voltage drops less when the capacitor is added in circuit. Although the max power is lower than the battery ES-341550-W and TLP-83111A/SM, in practical test, the GSM/GPRS module supplied with this power supply works normally in short-term application. But it is difficult to keep the battery voltage higher than 3.3V in long-term effective work.

### 2.1.3. Battery Comparison and Selection

According to GSM/GPRS power supply requirement of GSM/GPRS module, from the above different load mode testing, we can conclude that the battery ER34615M, ES-341550-W and TLP-83111A/SM can be used as power supply for GSM/GPRS module in lower power consumption application system. But we also should consider other aspects of requirement.

In terms of safe use, in general, these three types of battery are safe. But the ER34615M is power type battery, in order to provide high pulse current, the special internal structure of power type battery is different from the energy type battery. In some high temperature environment, and the battery discharges with high current, it may lead to explode. So the power type battery is forbidden to use in high temperature and flammable and explosive circumstance.

As we know, the Li-SOCI2 battery has a defect of voltage hysteresis. The battery voltage drops to much lower voltage after the battery being discharged in extremely current or stored a long period of time. As to battery pack with super capacitor, for example, ES-341550-W, this type battery can effective overcome

the defect of voltage hysteresis. But for ER34615M battery without super capacitor, in real application system, this defect can be overcome by discharge in high pulse current periodically.

From the aspect of price, the battery TLP-83111A/SM is a special customized voltage (3.9V) battery for GSM/GPRS module, so the price is very expensive. The following table shows the reference price for these three type battery.

**Table 4: Reference Price of Battery**

Battery Type	Price (1K pcs)
ER34615M	45 RMB
ES-341550-W	60 RMB
TLP-83111A/SM	360 RMB

In sum, all these three type battery can be used as power supply. According to the battery performance, the battery TLP-83111A/SM is an optimal choice. But, considering to the price requirement, the battery ES-341550-W is more suitable.

## 2.2. Application Reference Design

The power supply range of the module is 3.3V~ 4.3V. The voltage drop occurs during the transmitting burst time. As to the module, the power supply should not drop less than 3.3V because of the power supply protection function, or else the module will be shutdown automatically. In order to ensure the module working normally with low power supply, so the low power voltage shutdown and low power voltage warning function should be disabled. You can use the **AT+QVBATT** command to set or disable low voltage protection. Please refer to the **document [2]** for more details. For example:

**AT+QVBATT=0,3500,0**    Disable the low power voltage warning  
**AT+QVBATT=1,3300,0**    Disable the low power voltage shutdown  
**AT+QVBATT=1,3000,1**    Set the shutdown voltage to 3.0V

For GSM/GPRS module, only when the power for VBAT is higher than 3.2V can module be started from shutdown mode, so make sure that the power supply meets the start voltage requirement of module.

In the low power system, power supply and interface circuit have a great influence on low power consumption. Here are some reference designs with power supply and interface circuit as below.

### 2.2.1. Reference Design of Single Battery ES-341550-W

The following figure shows the reference design with a single battery ES-341550-W used as power supply. It is recommended to use this battery in your device.

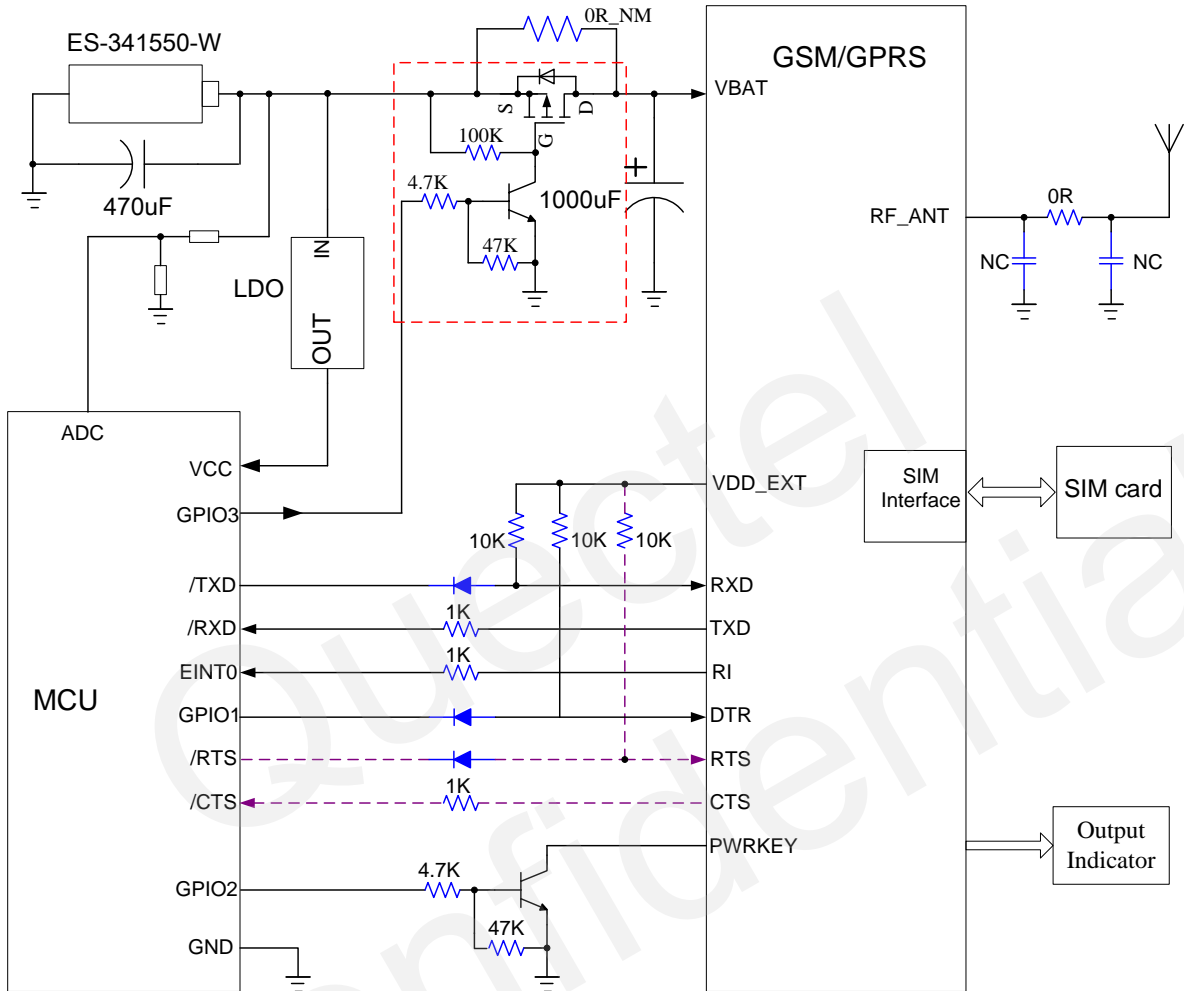

**Figure 7: Reference Design of Single Battery ES-341550-W**

#### NOTE

1. The dotted line circuit in purple is optional, you can remove this part circuit if do not need hardware flow control in practical application.
2. Diode circuit on the interface is used to avoid current flowing into the module. It can reduce the power consumption of MCU. It is recommended to use schottky diode with forward voltage less than 0.3V.
3. The circuit in red dotted rectangle can be removed when the GSM module need not shutdown the power supply.





### 2.2.3. Reference Design of Two Battery Packs

In order to achieve much longer usage time, the battery pack composes of same two high capacity batteries in series can be used as power supply. The output voltage is higher than the requirement of power supply of MCU and GSM/GPRS module, thus, the output voltage should be regulated to meet the requirements of power for GSM module and MCU. In order to increase the power conversion efficiency, it is better to use DC/DC convertor instead of LDO regulator.

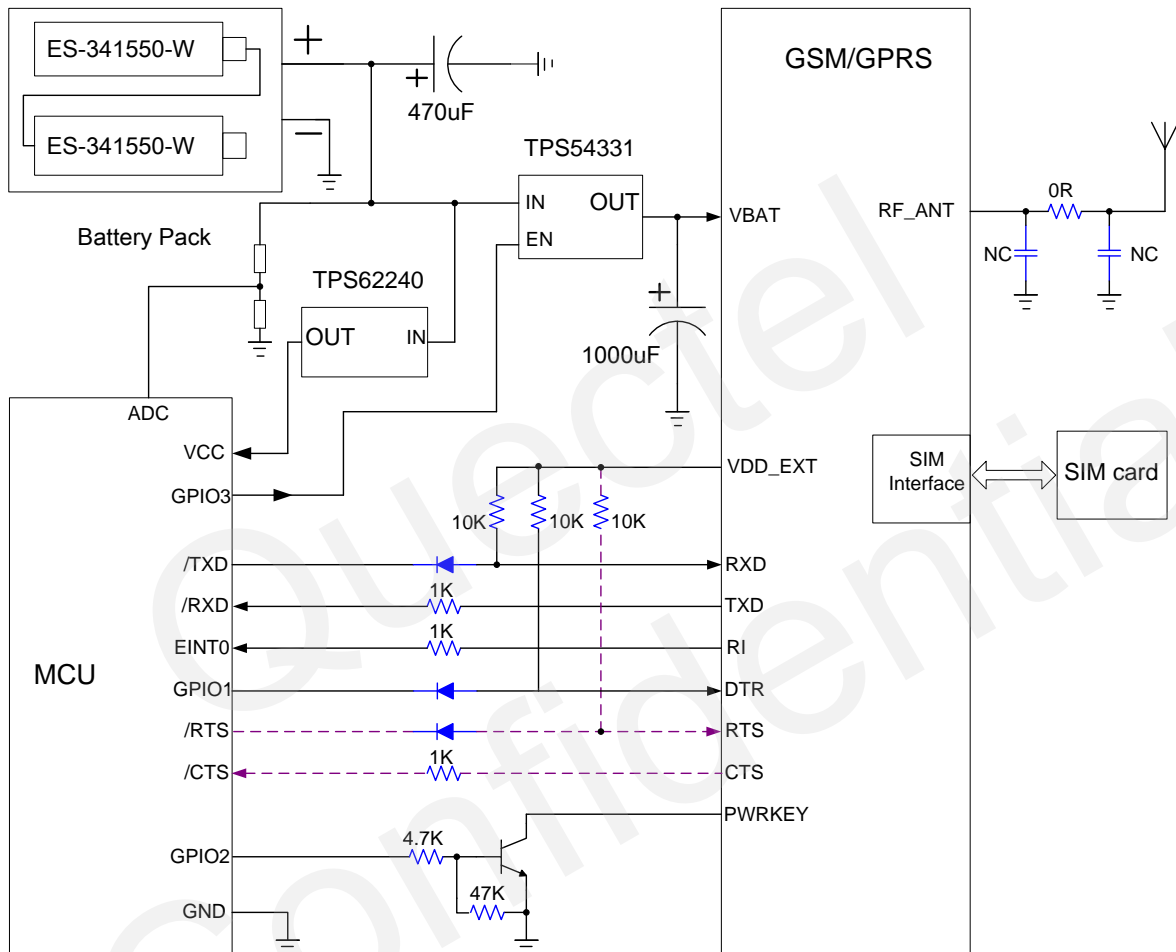

**Figure 9: Reference Design of Two Battery Packs of ES-341550-W**

#### NOTE

1. The dotted line circuit in purple is alternative, you can use it or not according to whether you need hardware flow control in practical application.
2. Diode circuit on the interface is used to avoid current flowing into the module. It can reduce the power consumption of MCU. It is recommended to use schottky diode with forward voltage less than 0.3V.

## 2.3. DC/DC Step Down Convertor

### 2.3.1. DC/DC Convertor Design

For the low power consumption application, as to the DC/DC convertor power supply for GSM/GPRS module, the DC/DC step down convertor selection should be complied with following rules.

- The input voltage range of DC/DC convertor should be wider than the output voltage range of battery.
- The max output current is up to 2.5A at least, and high efficiency at light loads.
- The switching frequency of convertor should not be very high and very low. It is about 500 KHz. The high switching frequency causes high switching loss that decreases the conversion efficiency. The low switching frequency of convertor needs a big size external inductor.
- Keep low current consumption in shutdown mode.

The recommended DC/DC convertor is TPS54331 from TI. The reference circuit of TPS54331 for GSM/GPRS module is as below:

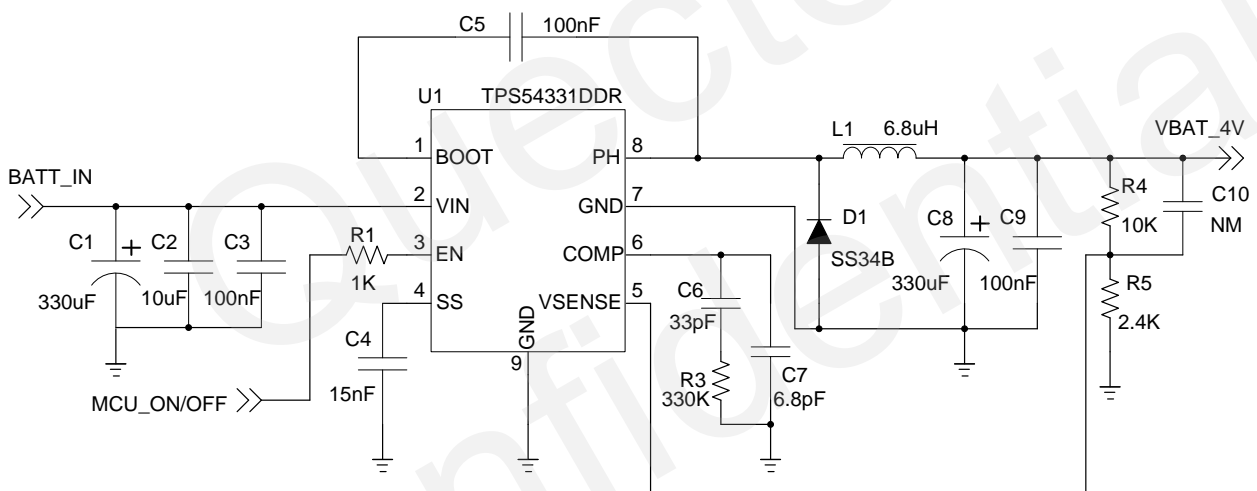

Figure 10: Reference Circuit of TPS54331

#### NOTE

The capacitor C7 and C6 and resistor R3 are frequency compensation components. The capacitance and resistance are calculated according to the specification of TPS54331.

### 2.3.2. DC/DC Layout Guideline

The DC/DC convertor requires a handful of external components, such as a power inductor, a catch diode, feedback resistors, and so on. Even with every external component properly selected, the converter's performance can still be compromised with a poor layout. A poor layout can result in a converter with

excessive output ripple voltage, poor load regulation, a poor dynamic load response, or a converter that radiates excessive electromagnetic interference (EMI). So the following layout guideline must be complied with.

- The VIN pin of TPS54331 should be bypassed to ground with a low ESR ceramic bypass capacitor. The capacitor should be closed to the VIN pin.
- Since the PH pin connection is the switching node, the catch diode and output inductor should be located very close to the PH pin, and the area of the PCB conductor is minimized to prevent excessive capacitive coupling. The trace from the PH pin to inductor should be isolated from other traces by the ground.
- Place the catch diode close to the PH pin to avoid long route, and keep the catch diode with good grounding.
- Place the feedback resistors close to the VSENSE pin. The feedback sampled point should be routed from the output of bypass capacitor. The feedback trace is noise-sensitive trace, so keep the feedback trace away from the inductor flux.
- For operation at full rated load, the top side ground area must provide adequate heat dissipating area, keep the bottom GND pad connected to the adequate ground area.
- The output voltage trace to the module should be wide enough to ensure that there is not too much voltage drop occurring during transmitting burst, so the trace width should be no less than 2mm.

## 2.4. Power Consumption of GSM/GPRS Module

In order to choose an appropriate capacity of battery in lower power design application, it is needed to evaluate the power consumption of GSM/GPRS module in normal working environment. In real GSM/GPRS network, the current consumptions of module in transmission mode and SMS mode are shown in following figures. It is a reference average current value. The power consumption is varied with different signal strength and other environment.

The work process of module in the test is as follows:

Start module→Searching network→Register to the network→Connect to network successfully→Transmit 1KB data in GRPS mode or send 472B in SMS mode→Succeed to transmit→Shut down module

**Table 5: Test Condition in Different Mode**

Mode	CSQ	GPRS Class	Data Size	Average Current
GPRS Data Transmission	29	Class 8	1024B	69.2mA
SMS Mode	29		472B	74.4mA

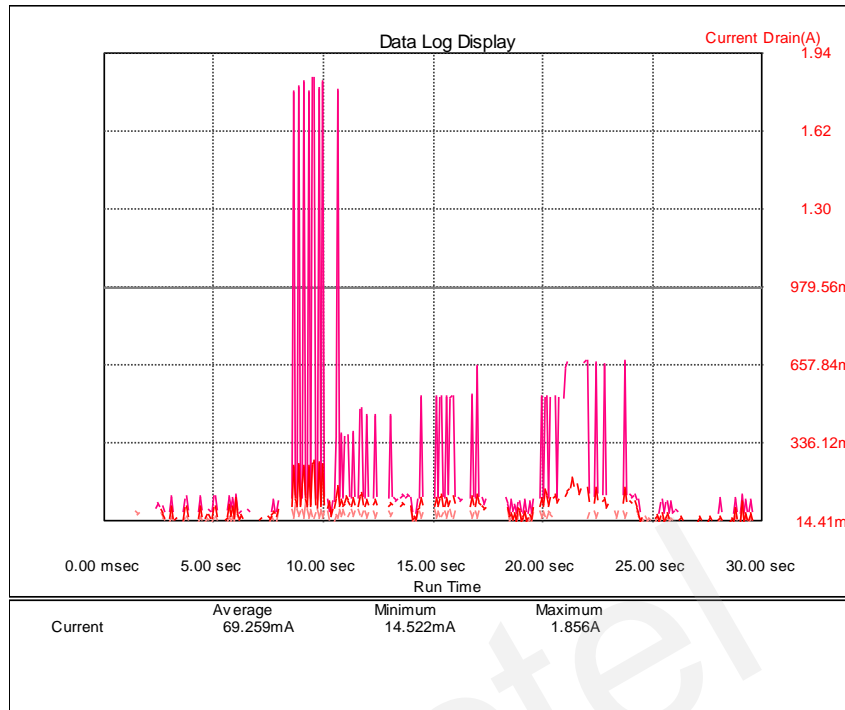

**Figure 11: Current Consumption of GPRS Data Transmission**

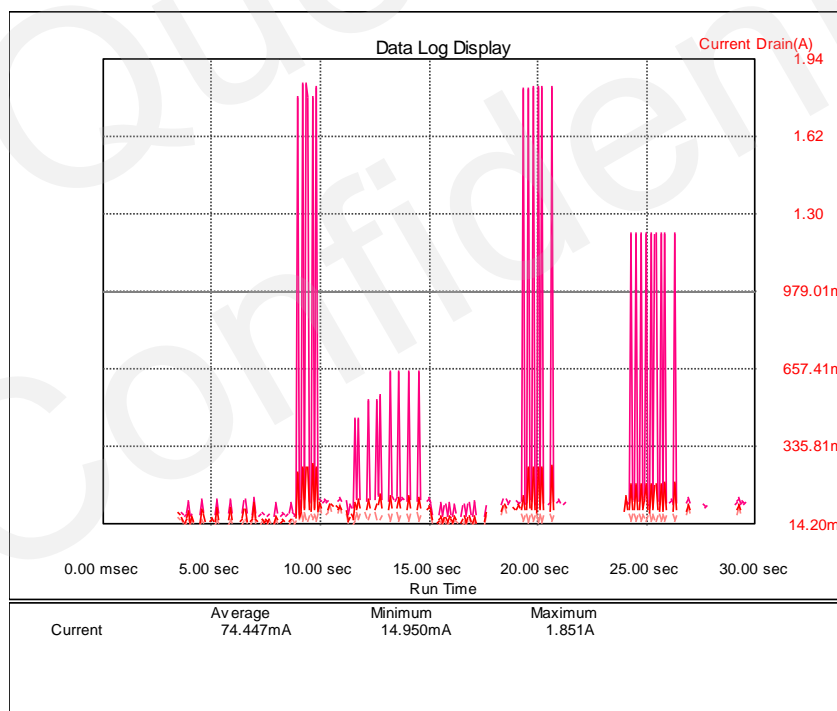

**Figure 12: Current Consumption of SMS Transmission**

As the above condition, the whole process will be finished in 30s, and under same external environment, and the data size is small, the current consumption of SMS transmission is higher than that of GPRS data module.

## 2.5. Battery Capacity Requirement Assessment

In practice, it is important to choose a suitable capacity of battery for low consumption device; also, it is difficult to calculate the exact requirement for battery capacity. It can be estimated by following ways.

The power consumption of the device can be calculated in two modes: sleep mode and working mode.

No matter which mode the device works, the power consumption of device can be divided into four parts: MCU control system, GSM/GPRS module system, self-discharge of battery and other external controlled target (e.g. valves).

Here is an example showing a calculation method of power consumption as follows, assume the device with 6 years of working time.

**Table 6: Example of Average Power Consumption in Different Mode**

System Unit	Sleep Mode	Work Mode (30s Every Time)
MCU Control System	5uA	16mA
GSM Module System	1uA (DC/DC is shut down)	130mA
External Controlled Target	4uA	40mA

**NOTE**

All values of power consumption in different mode are not actual values.

The device works one time a day, the power consumption of 6 years is:  
 $(16+130+40)(\text{mA}) \times 30\text{s} \times 1(\text{times}) \times 365(\text{days}) \times 6(\text{years})/3600=3394.5\text{mAh}$ ;

In sleep mode, the power consumption of 6 years is:  
 $(5+1+4)(\text{uA}) \times 24(\text{hours}) \times 365(\text{days}) \times 6(\text{years})/1000=525.6\text{mAh}$

The self-discharge rate of ER34615M is 3% after a year, so self-discharge of 6 years is:  
 $13000\text{mAh} \times 3\% \times 6(\text{years})=2340\text{mAh}$

So, the total power capacity requirement is :  $3394.5+525.6+2340\text{mAh}=6260.1\text{mAh}$

But in fact, to assure the battery can provide sufficient life time for the device, the capacity of battery adopted is always about twice that of theoretical calculation.

# 3 Measures for Reducing Power Consumption

In order to reduce the power consumption, when the device does not need data transmission, the MCU can switch off the power supply to the GSM/GPRS module. By this way, the current consumption of GSM/GPRS system is only the shutdown quiescent current of DC/DC convertor.

If the module cannot be shutdown in application, the module should enter into sleep mode when it does not work. In sleep mode, the power consumption can be reduced to 0.9mA~1.3mA. For the current consumption in sleep mode, please refer to the **document [1]**. By this way, the external MCU can also enter into sleep mode in idle to reduce the current consumption of MCU system.

The following ways can greatly improve power consumption of whole device.

- When the module is in sleep mode, the following methods can wake up the module.
  - 1) Pull DTR pin in the low level to wake up the module
  - 2) Receiving an SMS from network wakes up the module
- When MCU is in sleep mode, the following methods can wake up the module.
  - 1) Set a timer to wake up MCU automatically
  - 2) Wake up MCU through RI pin
- Use AT+QGPCLASS=8 to let the module enter into low power mode in the GPRS data transmitting. In this transmitting mode, the module has the lowest power consumption, normally 200mA. For details, please refer to the **document [1]**.
- Cut off the power supply of module when it does not work in idle time. The module will not cause power consumption.
- The better the load characteristic matches with the antenna port, the lower power consumption the module has. It is strongly recommended that the RF interface has an impedance of 50ohm. Keep the antenna in a place with stronger signal.
- The placement of the battery influences its discharge capacity. It is strongly recommended to place the battery vertically.
- For the MCU system, in order to reduce the wastage of battery in the long-term working time, try to use the low voltage MCU chip (such as the minimum voltage to 2V) or micro power consumption chipset.
- To alleviate battery passivation, it is recommended that the battery should not be discharged in very low current for long period. The device should discharge in high pulse current periodically by waking up and turning on GSM/GPRS module periodically.

# 4 AT Command for Low Power Consumption

You can use **AT+CDETXPW** command to reduce TX power. The following shows how to use this command in detail.

## 4.1. AT+CDETXPW TX Power Control

AT+CDETXPW is used to decrease the transmission power of module which can decrease the current consumption when module in GPRS data transferring.

AT+CDETXPW TX Power Control	
Test Command <b>AT+CDETXPW=?</b>	Response <b>+CDETXPW:</b> <rf_band>(850,900,1800,1900),<tx_slots>(1,2,3,4),<PCLx> ,<dBmValue>  <b>OK</b>
Write Command <b>AT+CDETXPW=&lt;rf_band&gt;,&lt;tx_slots&gt;,&lt;PCLx&gt;,&lt;dBmValue&gt;</b>	Response <b>OK</b>  If error is related to ME functionality: <b>ERROR</b>
Reference	

### Parameter

<b>&lt;rf_band&gt;</b>	Select band
850	GSM 850
900	GSM 900
1800	DCS 1800
1900	PCS 1900
<b>&lt;tx_slots&gt;</b>	Select GPRS uplink slot
1	GPRS uplink 1 slot
2	GPRS uplink 2 slots

	3	GPRS uplink 3 slots
	4	GPRS uplink 4 slots
<PCLx>	Power Control Level	
	GSM850/GSM900: 5~19	
	DCS1800/PCS1900: 0~15	
	All PCLs: 255	
<power_rollbk>	Set power rollback value	
	0	Restore default value
	1~12	Reduce 1dB~12dB

**NOTE**

The configuration of **AT+CDETXPW** command can be stored in NVRAM automatically.

**Example**

```
AT+CDETXPW=900,1,255,2 //Reduce 2dB on GSM900 band, apply to all PCLs.
OK
AT+CDETXPW=900,1,255,0 //Restore default value on GSM900 band, apply to all PCLs.
OK
```

## 4.2. Example of Reducing TX Power for GPRS Data Transmission

Following example describes how to reduce TX power when TCP data is transferring. Please refer to *GSM\_TCPIP\_AN.pdf* and *Mxx\_AT\_Command\_Manual.pdf* for more details of TCP function.

**Example**

```
RDY //Power on, automatically report URC.

+CFUN: 1

+CPIN: READY

Call Ready
AT+CREG?;+CGREG? //Query the case of attached network.
+CREG: 0,1

+CGREG: 0,1

OK
```



```
AT+QIFGCNT=0 //Set context 0 as the FGCNT.
OK
AT+QICSGP=1,"CMNET" //Set the APN as "CMNET".
OK
AT+QIMUX=0 //Disable MUXIP.
OK
AT+QIMODE=0 //Set the session mode as non-transparent.
OK
AT+QIDNSIP=0 //Use IP address to establish TCP/UDP session.
OK
AT+QGPCCLASS=8 //Set GPRS multi-slot class8.
OK
AT+CDETXPW=900,1,255,2 //Reduce 2dB on GSM900/ GPRS uplink 1 slot apply all PCLs.
OK
AT+QIOPEN="TCP", "124.74.41.170",5111
//Visit the remote TCP server. And the address of the remote server is
an IP address.
OK
CONNECT OK //CONNECT OK means the module successfully connected to the
remote TCP server.
AT+QISEND=12 //Send 10bytes data to remote server
>start0123end //>' from the UART to indicate the following input data is considered as
data to send.
SEND OK
AT+QISACK //Query the total size of the data sent and acknowledged.
+QISACK: 36, 24, 12 //The total size of the data sent is 36, the total size of the data
acknowledged is 24, the length of the data unacknowledged is 12.
OK
AT+QISACK //The data have been sent successfully.
+QISACK: 36, 36, 0
OK
AT+CDETXPW=900,1,255,0 //Restore default value on GSM900 band, apply to all PCLs.
OK
//Power off
```

### 4.3. Example of Reducing TX Power for SMS Data Transmission

Following example describes how to reduce TX power when SMS is transferring. Please refer to *GSM\_SMS\_AN.pdf* and *Mxx\_AT\_Command\_Manual.pdf* for more details of SMS function.

#### Example

```
RDY //Power on, automatically report URC.

+CFUN: 1

+CPIN: READY

Call Ready
AT+CREG? //Query the case of attached network.
+CREG: 0,1

OK
AT+CMGF=1 //Set the short message mode as TEXT mode.
OK
AT+CSMP=17,71,0,0 //Set the related parameters for sending short message in text mode.
OK
AT+CSCS="GSM" //Set the character mode as GSM mode.
OK
AT+CDETXPW=900,1,255,4 //Reduce 4dB on GSM900/ GPRS uplink 1 slot apply all PCLs.
OK
AT+CMGS="13817620516" //Send message to <da>"13817620516".
>test<Ctrl+Z>
+CMGS: 250

OK
AT+CDETXPW=900,1,255,0 //Restore default value on GSM900 band, apply to all PCLs
OK
//Power off
```

# 5 Appendix A Reference

Table 7: Reference Document

NO.	Document Name	Remark
[1]	Mxx_Hardware_Design	Mxx Hardware Design
[2]	Mxx_AT_Commands_Manual	Mxx AT Commands Manual
[3]	GSM_TCPIP_AN	GSM TCPIP application note
[4]	GSM_SMS_AN	GSM SMS application note

Quectel  
Confidential