



# BLINKIN LED DRIVER

**USER'S MANUAL**

# TABLE OF CONTENTS

1	OVERVIEW .....	3
1.1	CONNECTIONS .....	3
1.2	KIT CONTENTS .....	3
1.3	ELECTRICAL RATINGS .....	3
1.4	SUPPORTED LED STRIP TYPES.....	4
2	SETUP AND CONFIGURATION .....	5
2.1	GETTING STARTED .....	5
2.2	SETUP MODE .....	6
2.3	PWM CONTROL .....	7
2.4	<i>FIRST</i> ROBOTICS PROGRAMMING EXAMPLE .....	8
2.5	PATTERN ADJUSTMENTS .....	9
2.6	FACTORY RESET.....	9
3	EXAMPLE APPLICATIONS .....	10
3.1	<i>FIRST</i> ROBOTICS COMPETITION .....	10
3.2	<i>FIRST</i> TECH CHALLENGE.....	11
3.3	STAND-ALONE WIRING .....	12
3.4	COMPETITION ROBOTICS APPLICATION IDEAS .....	12
4	PHYSICAL DIMENSIONS .....	13
5	LED PATTERN TABLE .....	14

## LIST OF FIGURES

Figure 1: Blinkin Connections and Indicators .....	3
--	---

## LIST OF TABLES

Table 1: Kit Contents .....	3
Table 2: Status LED Blink Codes .....	5
Table 3: WPI Motor Control Output PWM Range.....	8
Table 4: Example SPARK Control Values based on Table 5 .....	8
Table 5: Excerpt from Section 6 LED Pattern List .....	8
Table 6: Blinkin Factory Default Values .....	9

# 1 OVERVIEW

The Blinkin is designed to make it straight forward to add controllable LEDs to a robot, cart, or any other project which would benefit from some extra lumens without needing any specialized programming. The Blinkin is a compact, all-in-one solution which can control LEDs in a stand-alone mode with just a 12V power source or in a dynamic mode, changing patterns by supplying a standard servo-style PWM signal.

## 1.1 CONNECTIONS

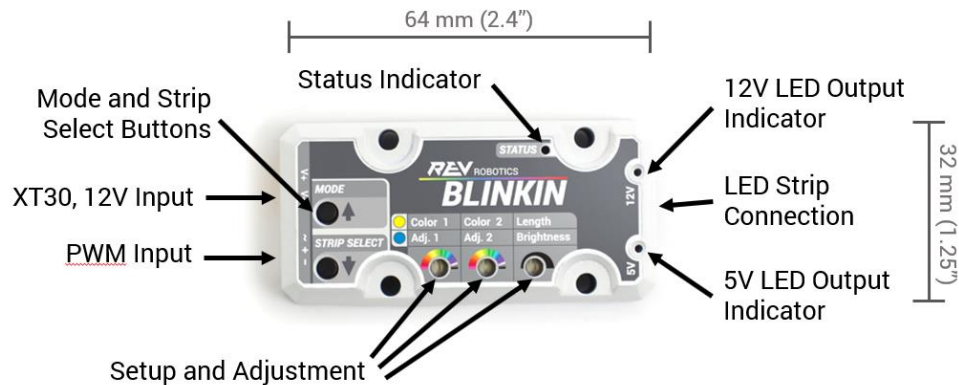

**Figure 1: Blinkin Connections and Indicators**

**Mode/Up Button** – Switch between normal running mode and set-up mode.

**Strip Select/Down Button** – Switch which kind of LED strip is being controlled.

**XT30 Power Input** – Connect to a 12V nominal battery or other equivalent power source.

**PWM Input** – Provide a standard servo-style PWM signal to control the LED output pattern/color.

**Status Indicator** – RGB LED mode indicator. See Table 2 for colors and meanings.

**Setup and Adjustment** – Three potentiometers are used to set customer color palette colors and addressable strip length in set-up mode (Section 2.2), and are used to adjust brightness and other pattern properties like speed and pattern density during normal operation (Section 2.5).

**5V/12V LED Indicators** – Indicate which kind of strip is currently selected as the output type (Section 2.1).

**LED Strip Connection** – Use the included JST PH, 7-pin to JST SM pigtail connector to connect to LED strip(s).

## 1.2 KIT CONTENTS

**Table 1: Kit Contents**

QTY	Part Number	Contents
1	REV-11-1105	REV-11-1105 Blinkin LED Driver
1	REV-11-1130*	PWM Cable
1	REV-31-1394*	XT30 Adapter Cable (Female Connector Only)
1	REV-11-1196	LED Adapter Cable
1		Small Screw Driver for Adjustment

\* Exact part included may vary, but is functionally equivalent to listed part number

## 1.3 ELECTRICAL RATINGS

---

Recommended input operating voltage is from 5.5V to 13.5V. Absolute input voltage range is 5.2V- 25V—use caution before exceeding the recommended input range to prevent damage.

**12V Input**

Minimum start-up operation for the 5V LEDs is 7V.

12V LEDs output is driven directly off this input voltage therefore lower or significantly higher input voltage may not allow for proper operation and may result in damage.

---

**12V LED Output**

Maximum of 12A output. Supports a minimum of 300 LEDs in series, or up to two strings of 300 in parallel. \* Equivalent to 10m of LEDs on 60 LED/m strips.

---

**5V LED Output**

Maximum of 5A output. Supports up to 240 LEDs for more patterns and brightness. \* Equivalent to 5m of LEDs on 60LED/m strips.

---

*\* If LEDs near the end of a strip are dimmer, off color or behaving erratically either the strip current is exceeding the current capability of the Blinkin or there is too much voltage drop over the strip length.*

**Problem: LEDs near the end of a strip are dimmer, off color, or behaving erratically.**

**Possible Cause:** LEDs are exceeding Blinkin current supply.

**Solution:** Turn down the strip brightness, shorten the strip, or use a pattern with less LEDs lit at the same time.

**Possible Cause:** There is too much voltage drop over the length of the strip so LEDs near the end don't have enough voltage to operate properly.

**Solution:** Shorten the LED strip or if more LEDs are needed shorten the strip and run the remaining strip in parallel to the other strip

## 1.4 SUPPORTED LED STRIP TYPES

The BLINKIN can drive either 12V RGB LEDs or 5V Individual addressable LED strips. Each strip type has its own benefits and drawbacks depending on what type of light display is desired.

---

**12V LEDs**

These LEDs are all connected together so the strip will always be all the same solid color, but this kind of LED strip is generally cheaper than the 5V kind. BLINKIN is designed for 12V Common Anode LEDs such as [REV-11-1197](#). These strips have a four-wire interface and can be cut to length every three LEDs.

---

**5V LEDs**





BLINKIN can control the WS2812 5V individually addressable LED type strips such as [REV-11-1198](#). This kind of strip is more expensive than the 12V type, but each individual LED can be a different color and brightness to create very colorful animations. These strips have a 3-wire interface and can be cut to length between each LED.

---

# 2 SETUP AND CONFIGURATION

The Blinkin operates in two modes, normal runtime operation and set-up mode. The Status LED will also indicate whether the Blinkin is currently measuring a valid PWM signal. See Table 2 for details.

**Table 2: Status LED Blink Codes**

State	PWM Measured	Status LED
Normal Operation	Valid PWM Input Detected	
Normal Operation	No PWM Input Detected	
Setup Mode	Valid PWM Input Detected	
Setup Mode	No PWM Input Detected	
Command Signal Detected—see Section 1 for details		

## 2.1 GETTING STARTED

1. Connect 12V power to the Blinkin using the yellow XT30
2. Select either a 12V or 5V Addressable LED strip and connect it to the Blinkin via the LED cable adapter ([REV-11-1196](#))
3. If the LED output indicator for the 12V/5V strip which is connected is not lit, press and hold the **Strip Select** button until the corresponding strip indicator LED is lit. Your LED strip should now be displaying the default pattern (29 – Color Waves, Party Palette), or the user programmed default pattern.

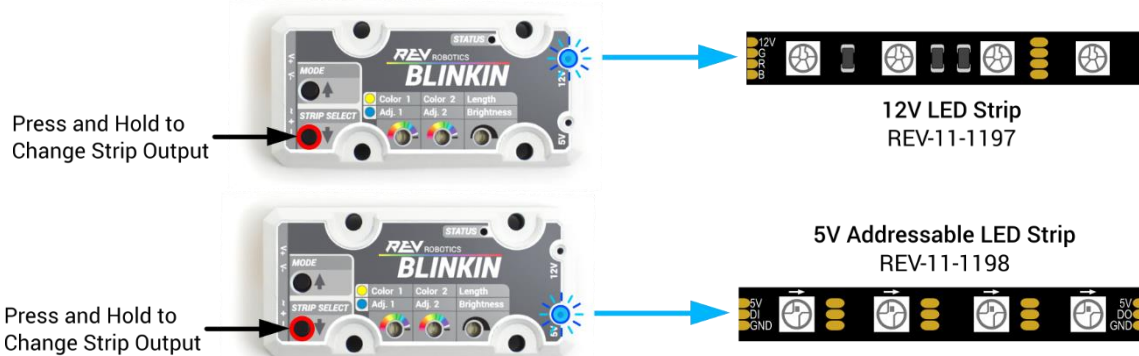

4. With no input PWM active (blue blinking **Status LED**), clicking (short press) the **Up (Mode)** and **Down (Strip Select)** buttons will change the pattern being displayed (See Section 5 for complete pattern list). This pattern will reset to the default after a power cycle unless the default is changed using the setup mode.

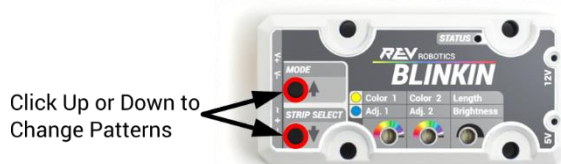

## 2.2 SETUP MODE

In addition to the pre-programmed fixed color palette patterns the Blinkin can be customized to use user selected colors and strip length to create more custom look. These settings can be saved in to permanent memory so they persist through power cycles.

Customizable Features	
•	Addressable Strip Length Up to 240 WS2812 LEDs
•	Team Color 1 and Team Color 2 Select two of 22 different color options to represent your team colors
•	Default No Signal Pattern Select which pattern is displayed with there is not PWM input (e.g. a disabled FRC robot)

1. Power up the Blinkin as described in Section 2.1. The LED strip selected cannot be changed during setup mode, so ensure that the desired strip is connected and running before continuing.



2. To enter Setup Mode, press and hold the **Mode** button for ~6 seconds, the **Status LED** will change from blue to yellow. The LED strip will automatically display pattern 75 which uses Color 1 and Color 2 to aid in configuration.



3. Use the included small screwdriver to adjust the three adjustment potentiometers
  - Left: Color 1 – Primary Pattern Color
  - Middle: Color 2 – Secondary Pattern Color
  - Right: Addressable Strip Number of LEDs (1-240)

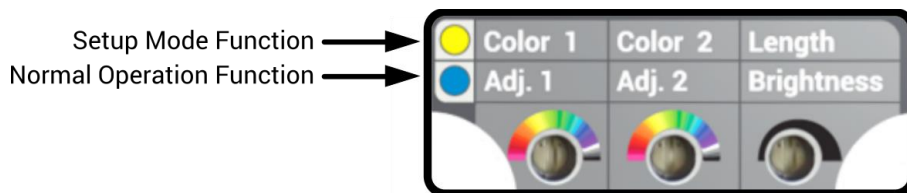

4. With no input PWM signal (yellow blinking **Status LED**), select the default no signal pattern by clicking (short press) the **Up (Mode)** and **Down (Strip Select)** buttons until the desired pattern is displayed. Leave the displayed pattern on the test pattern (75) on exit to leave the default no signal pattern unchanged.

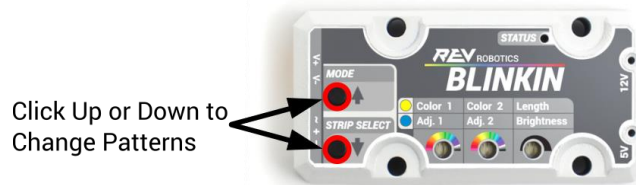

5. To Exit Setup mode:

- **Save and Exit:** Press and hold the **Mode** and **Strip Select** buttons for ~6 seconds. colors, strip length and new default no signal pattern values are permanently saved in EEPROM and will persist between power cycles.



- **Exit without Saving:** press and hold the **Mode** button. Nothing is saved and Blinkin will return to its previously saved state after power cycle.



6. The **Status LED** will return to blue when Setup Mode has been exited

## 2.3 PWM CONTROL

The Blinkin can be controlled via software using a standard servo-style PWM signal. The Blinkin measures the width of the incoming pulse from the PWM signal, and then based on that value selects a pattern from a corresponding pattern table. Valid input pulse widths are from 1000us to 2000us.

1. Connect the Blinkin to a PWM control port on the roboRIO (or other controller) using a standard PWM cable.
2. Using the programming language of your choice, generate a PWM signal.
  - For use with the FRC, create a motor of type SPARK. (Other Motor and Servo types will work, but might change the values associated with specific patterns)
3. In your main robot code where motor (or servo) output power is normally updated, set your output power to the value corresponding to the pattern desired (see Section 5). The output pattern can be changed during a match by updating the motor output power (in FRC, from -1 to 1). This can be tied to a button pressed by the driver, or automated based on sensor input or other events.

## 2.4 FIRST ROBOTICS PROGRAMMING EXAMPLE

In the FRC control system, motor outputs range varies depending on which type of motor controller is initialized. The output pulse range is scaled from the user requested output power of -1 to 1 to the range defined for each type of Motor controller.

**Table 3: WPI Motor Control Output PWM Range**

WPI Motor Control Open Type	Minimum Pulse Width Output (us)	Maximum Pulse Width Output (us)
SPARK	1000	2000
SRX	997	2004
Talon SR	989	2037
Jaguar	697	2322

From Table 3, the SPARK motor controller type output directly matches the input to the Blinkin, which makes the math to convert the -1 to 1 code range to the 1000-2000us Blinkin input range the simplest. Other control types, including servo, from the roboRIO can also be used, but the user will need to scale input range correctly to ensure they are sending only a valid PWM range and that they can select the desired LED pattern.

As an example, referencing Table 5 includes an excerpt from the Section 5 LED PATTERN TABLE, and includes the correct SPARK motor output value for each pattern Table 4 lists motor control values associated with specific patterns:

**Table 4: Example SPARK Control Values based on Table 5**

LED Color/Pattern	Motor Output Value
Ocean Colored Rainbow	-0.95
Larson Scanner (Similar to a Cylon)	-0.35
Fast Heartbeat in User Selected Team Color 1	0.07
Solid Blue	0.87

**Table 5: Excerpt from Section 5 LED Pattern List**

	Pulse Width (us)	roboRIO SPARK Value	Pattern Type	5V Strip Pattern
1	1005	-0.99	Fixed Palette Pattern	Rainbow, Rainbow Palette
2	1015	-0.97	Fixed Palette Pattern	Rainbow, Party Palette
3	1025	-0.95	Fixed Palette Pattern	Rainbow, Ocean Palette
...				
33	1325	-0.35	Fixed Palette Pattern	Larson Scanner, Red
...				
52	1515	0.03	Color 1 Pattern	Heartbeat Slow
53	1525	0.05	Color 1 Pattern	Heartbeat Medium
54	1535	0.07	Color 1 Pattern	Heartbeat Fast
...				
77	1765	0.53	Color 1 and 2 Pattern	Color Waves, Color 1 and 2
...				
94	1935	0.87	Solid Colors	Blue
95	1945	0.89	Solid Colors	Blue Violet
96	1955	0.91	Solid Colors	Violet



## 2.5 PATTERN ADJUSTMENTS

All of the LED strips and patterns can have their overall brightness adjusted and many of the patterns can be adjusted to change the pattern density and speed. Section 5 details what patterns have which adjustments.

1. In Normal Mode (Not in Setup Mode) select a pattern which is adjustable
2. Using the small included screwdriver and change Adj.1 Adj.2 and brightness to change the pattern behavior

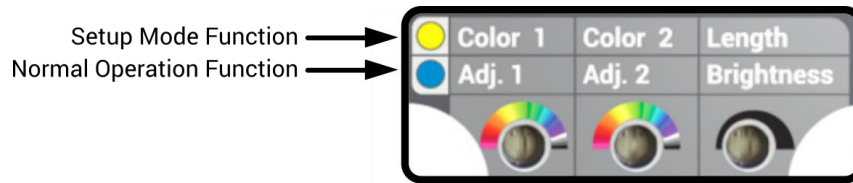

## 2.6 FACTORY RESET

The Blinkin can store custom user setting in EEPROM so that it persists through power cycles, see Section 2.2 for details. Restore the Blinkin to factory default settings using the following procedure:

1. Power off the Blinkin
2. Press and hold the **Mode** and **Strip Select** buttons

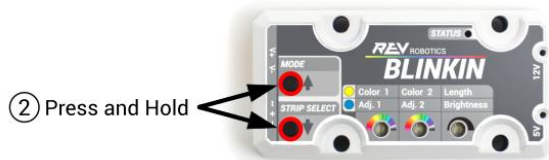

3. Power on the Blinkin

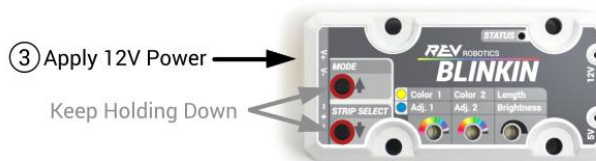

4. Wait for ~2 Seconds
5. Release the **Mode** and **Strip Select** buttons

After completing the factory reset the default values found in Table 6 will be reloaded into permanent memory.

**Table 6: Blinkin Factory Default Values**

Variable	Default Value
Color 1	Sky Blue – 0x0080FF
Color 2	Gold – 0xFFEA00
Strip Length	60 LEDs
No Signal Pattern	29 – Color Waves, Party Palette
Strip Select	5V

# 3 EXAMPLE APPLICATIONS

## 3.1 FIRST ROBOTICS COMPETITION

Always be sure to read the relevant rules and use appropriate gauge wiring before using anything on your competition robot.

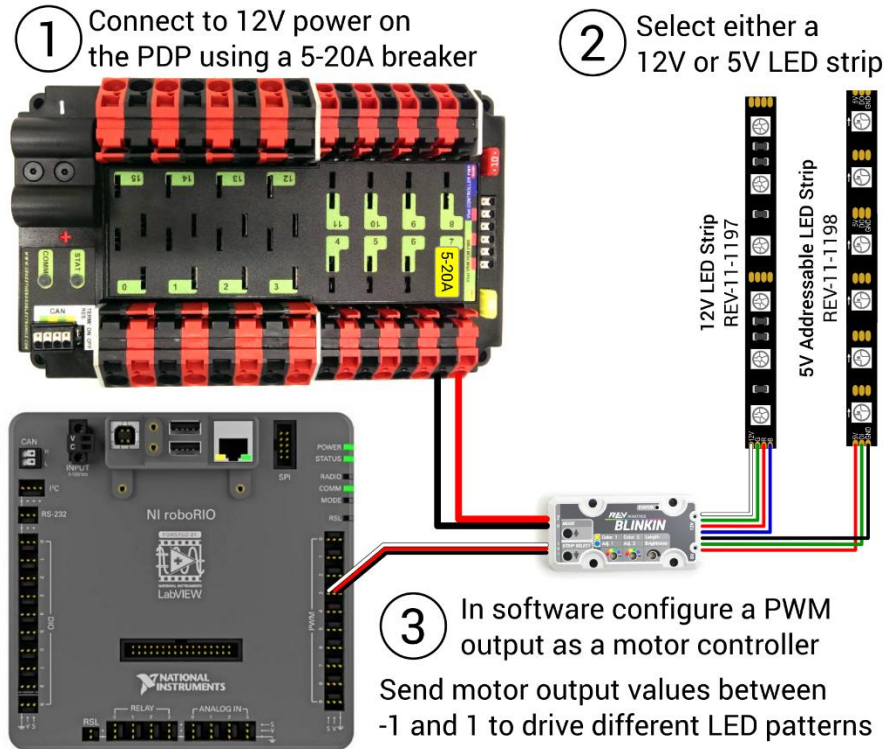

After wiring you Blinkin into your robot, follow the setup instructions in Section 2.2 and follow the instructions on PWM control in Section 2.3 as desired.

## 3.2 FIRST TECH CHALLENGE

Please note that the Blinkin is **NOT** competition legal for the 2017-2018 FTC season. The following wiring information is for adding LEDs for demonstrations and unofficial events.

- 1 Connect to 12V from a spare XT30 port on the Expansion Hub or a Y cable from the battery
- 2 Select either a 12V or 5V LED strip

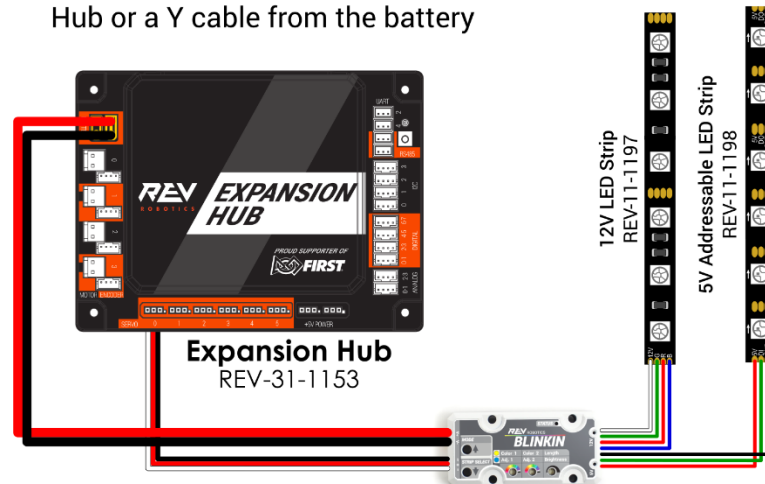

- 3 Connect PWM cable to a Servo output on the Expansion Hub  
Send servo output values between 0.2525 and 0.7475 to drive different LED patterns

### 3.3 STAND-ALONE WIRING

The Blinkin can run in a stand-alone operation mode when there is no way to generate a PWM signal, or a single output pattern is all that is needed. In this mode the Blinkin will be operating in Normal Mode with no input signal (blue blinking LED) and will default to the programmed no input signal pattern (factory setting is pattern 29 – Color Waves, Party Palette).

The currently displayed pattern can be changed at any time by pressing the up and down buttons to scroll through the pattern list (Section 5). Unless a new default no signal test pattern is saved in memory by completing the setup mode process, the Blinkin will default back to the last saved pattern after a power cycle.

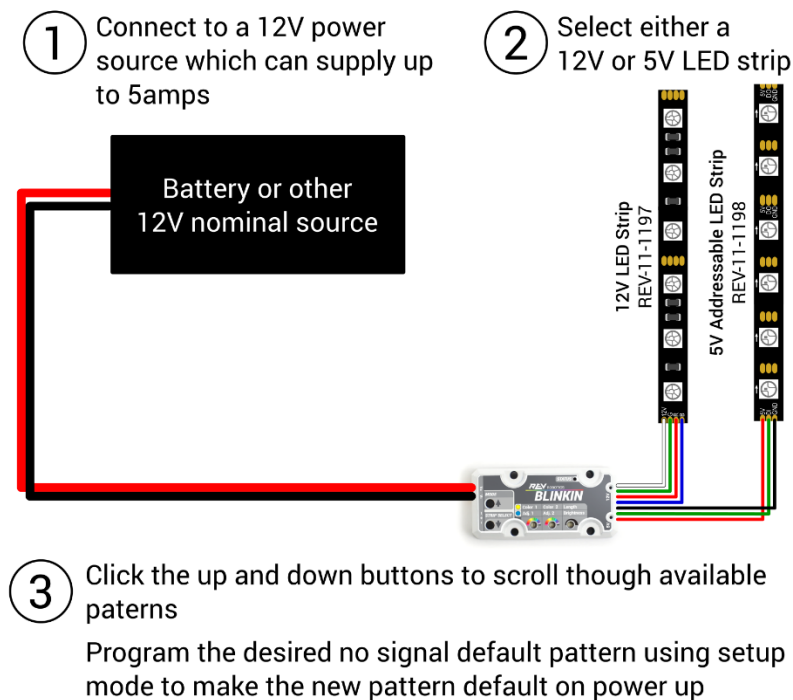

### 3.4 COMPETITION ROBOTICS APPLICATION IDEAS

Adding LEDs to your robot (or other project) can do more than just make them look cool, you can use LEDs to provide critical visual feedback. Here are some examples:

- Program a controller button to change the LED output pattern (e.g. 85 – Solid Yellow) and the drive can use the LEDs to communicate to the human player at a portal station across the field that the robot is ready to receive a game object.
- If the driver has poor visibility to see if the robot has acquired a game object, add a sensor to the intake and the LED strip can be programmed to automatically display a new pattern when the object is acquired. The driver never has to take their eyes off the robot to check the dashboard because the robot will clearly display its status.
- Using the match time value available in software, the LEDs can be changes to a time warning pattern (e.g. – Solid Red) with X seconds left in a match.
- The robot can display a different pattern when enabled vs disabled which provides a more visible indicator of the state of the robot than the RSL.

# 4 PHYSICAL DIMENSIONS

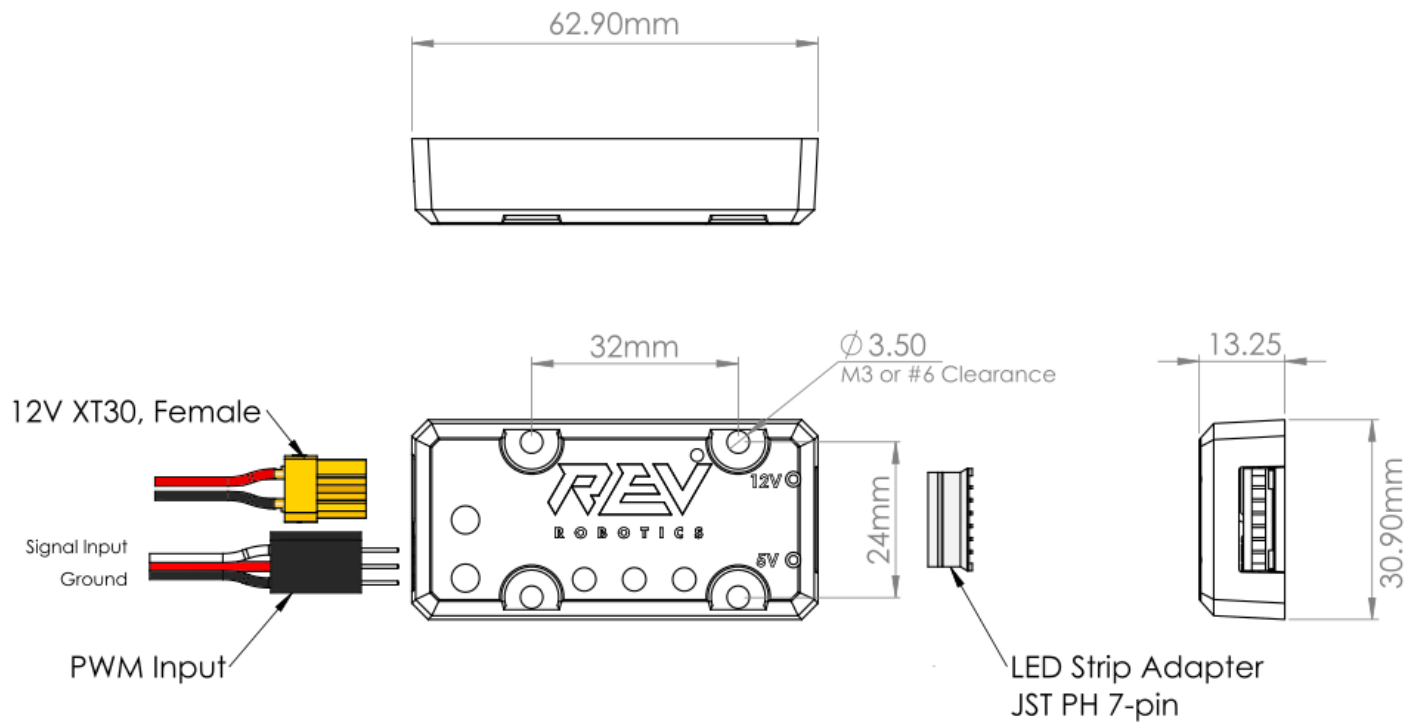

# 5 LED PATTERN TABLE

This table primarily describes the behavior of the 5V addressable LEDs as they are capable of more complicated patterns. 12V LEDs will all show patterns with the same color palette as the pattern selected and the speed can be adjusted as indicated for the selected pattern.

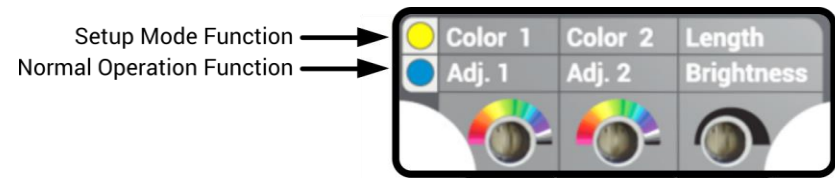

	Pulse Width (us)	roboRIO SPARK Value	Pattern Type	5V Strip Pattern	Normal Operation Adjustment 1	Normal Operation Adjustment 2	Normal Operation Brightness
1	1005	-0.99	Fixed Palette Pattern	Rainbow, Rainbow Palette	Pattern Density	Speed	Brightness
2	1015	-0.97	Fixed Palette Pattern	Rainbow, Party Palette	Pattern Density	Speed	Brightness
3	1025	-0.95	Fixed Palette Pattern	Rainbow, Ocean Palette	Pattern Density	Speed	Brightness
4	1035	-0.93	Fixed Palette Pattern	Rainbow, Lava Palette	Pattern Density	Speed	Brightness
5	1045	-0.91	Fixed Palette Pattern	Rainbow, Forest Palette	Pattern Density	Speed	Brightness
6	1055	-0.89	Fixed Palette Pattern	Rainbow with Glitter	Pattern Density	Speed	Brightness
7	1065	-0.87	Fixed Palette Pattern	Confetti	Pattern Density	Speed	Brightness
8	1075	-0.85	Fixed Palette Pattern	Shot, Red	-	-	Brightness
9	1085	-0.83	Fixed Palette Pattern	Shot, Blue	-	-	Brightness
10	1095	-0.81	Fixed Palette Pattern	Shot, White	-	-	Brightness
11	1105	-0.79	Fixed Palette Pattern	Sinelon, Rainbow Palette	Pattern Density	Speed	Brightness
12	1115	-0.77	Fixed Palette Pattern	Sinelon, Party Palette	Pattern Density	Speed	Brightness
13	1125	-0.75	Fixed Palette Pattern	Sinelon, Ocean Palette	Pattern Density	Speed	Brightness
14	1135	-0.73	Fixed Palette Pattern	Sinelon, Lava Palette	Pattern Density	Speed	Brightness
15	1145	-0.71	Fixed Palette Pattern	Sinelon, Forest Palette	Pattern Density	Speed	Brightness
16	1155	-0.69	Fixed Palette Pattern	Beats per Minute, Rainbow Palette	Pattern Density	Speed	Brightness
17	1165	-0.67	Fixed Palette Pattern	Beats per Minute, Party Palette	Pattern Density	Speed	Brightness
18	1175	-0.65	Fixed Palette Pattern	Beats per Minute, Ocean Palette	Pattern Density	Speed	Brightness
19	1185	-0.63	Fixed Palette Pattern	Beats per Minute, Lava Palette	Pattern Density	Speed	Brightness
20	1195	-0.61	Fixed Palette Pattern	Beats per Minute, Forest Palette	Pattern Density	Speed	Brightness
21	1205	-0.59	Fixed Palette Pattern	Fire, Medium	-	-	Brightness
22	1215	-0.57	Fixed Palette Pattern	Fire, Large	-	-	Brightness
23	1225	-0.55	Fixed Palette Pattern	Twinkles, Rainbow Palette	-	-	Brightness
24	1235	-0.53	Fixed Palette Pattern	Twinkles, Party Palette	-	-	Brightness
25	1245	-0.51	Fixed Palette Pattern	Twinkles, Ocean Palette	-	-	Brightness

26	1255	-0.49	Fixed Palette Pattern	Twinkles, Lava Palette	-	-	Brightness
27	1265	-0.47	Fixed Palette Pattern	Twinkles, Forest Palette	-	-	Brightness
28	1275	-0.45	Fixed Palette Pattern	Color Waves, Rainbow Palette	-	-	Brightness
29	1285	-0.43	Fixed Palette Pattern	Color Waves, Party Palette	-	-	Brightness
30	1295	-0.41	Fixed Palette Pattern	Color Waves, Ocean Palette	-	-	Brightness
31	1305	-0.39	Fixed Palette Pattern	Color Waves, Lava Palette	-	-	Brightness
32	1315	-0.37	Fixed Palette Pattern	Color Waves, Forest Palette	-	-	Brightness
33	1325	-0.35	Fixed Palette Pattern	Larson Scanner, Red	Pattern Width	Speed	Brightness
34	1335	-0.33	Fixed Palette Pattern	Larson Scanner, Gray	Pattern Width	Speed	Brightness
35	1345	-0.31	Fixed Palette Pattern	Light Chase, Red	Dimming	Speed	Brightness
36	1355	-0.29	Fixed Palette Pattern	Light Chase, Blue	Dimming	Speed	Brightness
37	1365	-0.27	Fixed Palette Pattern	Light Chase, Gray	Dimming	Speed	Brightness
38	1375	-0.25	Fixed Palette Pattern	Heartbeat, Red	-	-	Brightness
39	1385	-0.23	Fixed Palette Pattern	Heartbeat, Blue	-	-	Brightness
40	1395	-0.21	Fixed Palette Pattern	Heartbeat, White	-	-	Brightness
41	1405	-0.19	Fixed Palette Pattern	Heartbeat, Gray	-	-	Brightness
42	1415	-0.17	Fixed Palette Pattern	Breath, Red	-	-	Brightness
43	1425	-0.15	Fixed Palette Pattern	Breath, Blue	-	-	Brightness
44	1435	-0.13	Fixed Palette Pattern	Breath, Gray	-	-	Brightness
45	1445	-0.11	Fixed Palette Pattern	Strobe, Red	-	-	Brightness
46	1455	-0.09	Fixed Palette Pattern	Strobe, Blue	-	-	Brightness
47	1465	-0.07	Fixed Palette Pattern	Strobe, Gold	-	-	Brightness
48	1475	-0.05	Fixed Palette Pattern	Strobe, White	-	-	Brightness
49	1485	-0.03	Color 1 Pattern	End to End Blend to Black	-	-	Brightness
50	1495	-0.01	Color 1 Pattern	Larson Scanner	Pattern Width	Speed	Brightness
51	1505	0.01	Color 1 Pattern	Light Chase	Dimming	Speed	Brightness
52	1515	0.03	Color 1 Pattern	Heartbeat Slow	-	-	Brightness
53	1525	0.05	Color 1 Pattern	Heartbeat Medium	-	-	Brightness
54	1535	0.07	Color 1 Pattern	Heartbeat Fast	-	-	Brightness
55	1545	0.09	Color 1 Pattern	Breath Slow	-	-	Brightness
56	1555	0.11	Color 1 Pattern	Breath Fast	-	-	Brightness
57	1565	0.13	Color 1 Pattern	Shot	-	-	Brightness
58	1575	0.15	Color 1 Pattern	Strobe	-	-	Brightness
59	1585	0.17	Color 2 Pattern	End to End Blend to Black	-	-	Brightness
60	1595	0.19	Color 2 Pattern	Larson Scanner	Pattern Width	Speed	Brightness
61	1605	0.21	Color 2 Pattern	Light Chase	Dimming	Speed	Brightness
62	1615	0.23	Color 2 Pattern	Heartbeat Slow	-	-	Brightness
63	1625	0.25	Color 2 Pattern	Heartbeat Medium	-	-	Brightness

64	1635	0.27	Color 2 Pattern	Heartbeat Fast	-	-	Brightness
65	1645	0.29	Color 2 Pattern	Breath Slow	-	-	Brightness
66	1655	0.31	Color 2 Pattern	Breath Fast	-	-	Brightness
67	1665	0.33	Color 2 Pattern	Shot	-	-	Brightness
68	1675	0.35	Color 2 Pattern	Strobe	-	-	Brightness
69	1685	0.37	Color 1 and 2 Pattern	Sparkle, Color 1 on Color 2	-	-	Brightness
70	1695	0.39	Color 1 and 2 Pattern	Sparkle, Color 2 on Color 1	-	-	Brightness
71	1705	0.41	Color 1 and 2 Pattern	Color Gradient, Color 1 and 2	-	-	Brightness
72	1715	0.43	Color 1 and 2 Pattern	Beats per Minute, Color 1 and 2	Pattern Density	Speed	Brightness
73	1725	0.45	Color 1 and 2 Pattern	End to End Blend, Color 1 to 2	-	-	Brightness
74	1735	0.47	Color 1 and 2 Pattern	End to End Blend	-	-	Brightness
75	1745	0.49	Color 1 and 2 Pattern	Color 1 and Color 2 no blending (Setup Pattern)	-	-	Brightness
76	1755	0.51	Color 1 and 2 Pattern	Twinkles, Color 1 and 2	-	-	Brightness
77	1765	0.53	Color 1 and 2 Pattern	Color Waves, Color 1 and 2	-	-	Brightness
78	1775	0.55	Color 1 and 2 Pattern	Sinelon, Color 1 and 2	Pattern Density	Speed	Brightness
79	1785	0.57	Solid Colors	Hot Pink	-	-	Brightness
80	1795	0.59	Solid Colors	Dark red	-	-	Brightness
81	1805	0.61	Solid Colors	Red	-	-	Brightness
82	1815	0.63	Solid Colors	Red Orange	-	-	Brightness
83	1825	0.65	Solid Colors	Orange	-	-	Brightness
84	1835	0.67	Solid Colors	Gold	-	-	Brightness
85	1845	0.69	Solid Colors	Yellow	-	-	Brightness
86	1855	0.71	Solid Colors	Lawn Green	-	-	Brightness
87	1865	0.73	Solid Colors	Lime	-	-	Brightness
88	1875	0.75	Solid Colors	Dark Green	-	-	Brightness
89	1885	0.77	Solid Colors	Green	-	-	Brightness
90	1895	0.79	Solid Colors	Blue Green	-	-	Brightness
91	1905	0.81	Solid Colors	Aqua	-	-	Brightness
92	1915	0.83	Solid Colors	Sky Blue	-	-	Brightness
93	1925	0.85	Solid Colors	Dark Blue	-	-	Brightness
94	1935	0.87	Solid Colors	Blue	-	-	Brightness
95	1945	0.89	Solid Colors	Blue Violet	-	-	Brightness
96	1955	0.91	Solid Colors	Violet	-	-	Brightness
97	1965	0.93	Solid Colors	White	-	-	Brightness
98	1975	0.95	Solid Colors	Gray	-	-	Brightness
99	1985	0.97	Solid Colors	Dark Gray	-	-	Brightness
100	1995	0.99	Solid Colors	Black	-	-	Brightness