

Rinnai

Continuum and Integrity

REU2532-W and REU2532-WC

Series Water Heaters

SERVICE MANUAL

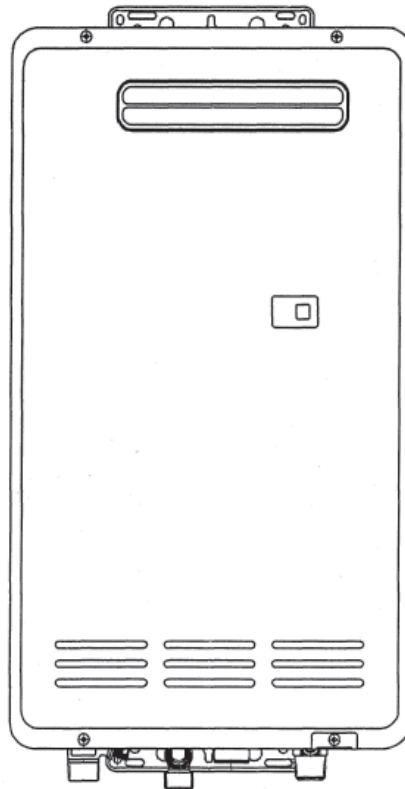

*Rinnai Corporation
103 International Drive
Peachtree City, Ga. 30269
Telephone number (800)621-9419*

No portion or part of this manual may be copied without prior permission from Rinnai Corporation.

Key to Warning Symbols



Failure to comply with the following instructions may result in serious personal injury or damage to the appliance.



Be careful of possible electric shock. Wiring inside this appliance may potentially be at 120 volts.



Disconnect power supply to unit when carrying out the following service repairs.



Read Fault Diagnosis and Wiring Diagram carefully to avoid incorrect wiring.



Do not disassemble. Parts within can not be exchanged or diagnosed faulty.

Please follow instructions in chapters to ensure safe and appropriate service.

After completing the service and confirming that there are no water or gas leaks or incorrect wiring, test operation of the appliance. After confirming normal operation, explain what was serviced to the customer and the operating principles, if necessary.

The information in this manual was compiled by Rinnai Technical Services. While many individuals have contributed to this publication, it will be successful only if you – the reader and customer – find it useful. We would like to extend an invitation to users of this manual to make contact with us, as your feedback and suggestions are valuable resources for us to include as improvements. Rinnai is constantly working toward supplying improved appliances as well as information, and specifications may be subject to alteration at any time.

Table of Contents

Glossary of Terms and Symbols	4
1. Introduction	5
2. Features	6
3. Dimensions	8
4. Installation	9
5. Remote Controls	10
6. Safety Devices	12
7. Specification	14
8. Cut-away Diagram	16
9. Schematic Diagram	17
10. Combustion Specifications	18
11. Dip Switch Positions	19
12. Water Flows	22
13. Main Components	24
14. Time Charts	26
15. Operation Flow Principle	28
16. Operation Principles	30
17. Error Messages	32
18. Diagnostic Points	34
19. Wiring Diagram	35
20. Fault Diagnosis	36
21. Electrical Component Analysis	37
22. Gas Conversion	47
23. Gas Pressure Setting Procedure	52
24. Dismantling for Service	54
25. Exploded Diagram	60
26. Parts List	64
27. Troubleshooting Sheets	69

Glossary of Terms and Symbols

This glossary of terms and symbols is provided to assist you in understanding some of the language used throughout this manual.

DB(A)	-	sound pressure level in decibels, “A” range
DC	-	direct current
AC	-	alternating current
WFCD	-	water flow control device
FB	-	feedback information
Hz.	-	hertz
IC	-	integrated circuit
BTU/H	-	British thermal units
PSI	-	Pounds per square inch
LED	-	light emitting diode
GPM	-	gallons per minute
mA	-	milliamps
W.C.	-	inches of water column
mm	-	millimeters
Nox	-	oxides of nitrogen NO & NO₂
OHS	-	overheat switch
PCB	-	printed circuit board
CPU	-	central processing unit
POT	-	potentiometer
rpm	-	revolutions per minute
SV	-	solenoid valve
Ø	-	diameter
Δ °F	-	delta T or temperature rise above ambient
POV	-	modulating valve
TE	-	thermal efficiency
TH	-	thermistor
T_{IN}	-	temperature of incoming water
T_{out}	-	temperature of outgoing water

1. Introduction

The brand name Continuum refers to “Endless Hot Water”. The new Continuum series has been developed in response to the growing changes in the lifestyle of our customers, and the increasing diversification and sophistication of demand in the marketplace.

The Continuum series offers reduced cost with advanced safety features, and an option to connect one, two, or three remote temperature control pads to the residential units. The commercial units only allow one keypad per heater.

The Continuum REU-2532 series is delivered with the maximum hot water temperature output set at 120 °F without the remote control. When using controllers you can adjust your hot water output from 96 – 120 °F using the “BC” and “BSC” controllers. The “MC” control will allow water temperature adjustments from 96 – 140 °F, and the “MCC” control used only with the commercial unit, allows adjustments from 96 - 180°F. .

About the Continuum

The front cover of each appliance in the new series is formed from 0.6 mm coated steel. Secured to the main box assembly by (4) screws. Seals around the front cover prevent water from entering the appliance.

Air inlets are situated in the front panel of the 2532 external unit. Air passes through the inlets and is drawn into the combustion chamber at the left side of the fan housing. The by-products of combustion on the external unit are expelled from the appliance through the flue outlet situated on the front of the appliance, at the top. The general layout of components can be seen in the cut-away diagram, see table of contents for page number. All components are supported within the unit’s casing, which is made from 0.8 mm coated steel.

The heat exchanger occupies the top section of the casing, and the burner is situated in a chamber formed from 0.8 mm aluminized steel, attached to the bottom of the heat exchanger. The copper tubing material used in the heat exchanger consist of, Phosphorus Dioxide Copper, (C1220P). The material used to solder the heat exchanger pipes is, Phosphorus Bronze Brazing, (main components are P, Ag, and Cu) (JIS No. BcuP-2). None of these materials contain lead.

The air for combustion is supplied by a fan, which is connected to the burner box by a duct at the left side of the appliance, directly under the burner.

Gas and water controls are situated at the bottom right of the appliance, directly under the manifold. The “O”ring material on the water and gas connections are made from EPDM, (Ethylene Propylene Diene) rubber.

The burner assembly is made up of (16) identical stainless steel Bunsen burners, secured by an aluminized steel framework. Each burner is capable of handling up to 11,250 BTU’s. An aluminum manifold with (32) integrally molded injectors supplies gas to the burners, and is attached to the front lower cover of the burner box.

2. Features

Installation

The lightweight, slim, compact design enables ease of installation and improved appearance. The remote controls (where fitted) are connected to the appliance by (2) core non-polar cable, or low voltage thermostat wire, ensuring easy wiring and eliminating problems of mis-connections. Since the remotes use a 12 VDC digital signal, there's no-way you can cross up the wiring. You can connect the black wires to black wires at one terminal, black and white at another, and still not short the units out.

Low Noise Level

Low noise level design enables these appliances to be installed in apartment units, townhouses, and other high density residential areas with little concern about noise disturbances.

Safety

Various safety devices controlled by a micro- computer ensure complete safety. Also, the anti-frost device automatically prevents the water inside the appliance from freezing by using small electrical ceramic heaters, connected to the pipe-work at strategic locations throughout the appliance. The unit has a secondary freeze prevention device that will allow the unit to fire for three seconds if the water temperature inside the appliance drops below 37 °F. This mode will heat the water inside the unit back up to 57 °F. The anti-frost devices should prevent the unit from freeze-ups down to the -30 °F, in a no wind situation. This feature functions as long as the unit has power and gas.

Economy

Direct ignition to the main burner eliminates wasteful pilot gas consumption. The combustion fan rpm is proportionally controlled with the gas consumption. This maintains high energy efficiency, as the gas consumption changes with increased or decreased water flows. The unit's thermal efficiency rating is; 0.85 for (LP) units and 0.79 for natural gas units.

Water Supply Control

The water supply capacity varies proportionally from 0.5 to 8.5 GPM's. A suitable volume of hot water can be supplied throughout all seasons by the water flow control device and water flow servomechanism. The Continuum 2532 series will supply up to 6.5 GPM's at a 50°F rise or up to 8.5 GPM's at a 35 degree rise, controlled by an automatic electro-mechanical water control flow device. Details pertaining to water flows can be found in the water flow charts in this manual.

Water Temperature Control

With an “MC” remote control connected, the hot water control range at the key pad is 96 – 140 °F. The “BC” and “BSC” key pads allow for adjustments between 96 – 120 °F. The “MCC” key pad allows the commercial unit to be adjusted from 96 – 180 ° F. This allows the Continuum to be set to comply with various State codes pertaining to maximum water temperatures allowed for homes, child care centers, elderly care centers, etc. where the water temperature can not exceed a certain set point.

Over Temperature Control

All Continuum models incorporate a device to prevent the hot water temperature from exceeding the pre-set temperature by more than 4 °F.

Temperature Locks

With the remote control(s) connected, the pre-set water temperature can only be altered between 96 – 110 °F while water is flowing. Also, if the remote control circuit fails while water is flowing, the unit defaults back to 100 °F. That prevents inadvertently increasing the temperature to a hazardous level while someone is in the shower. This is an Anti-Scald feature.

3. Dimensions

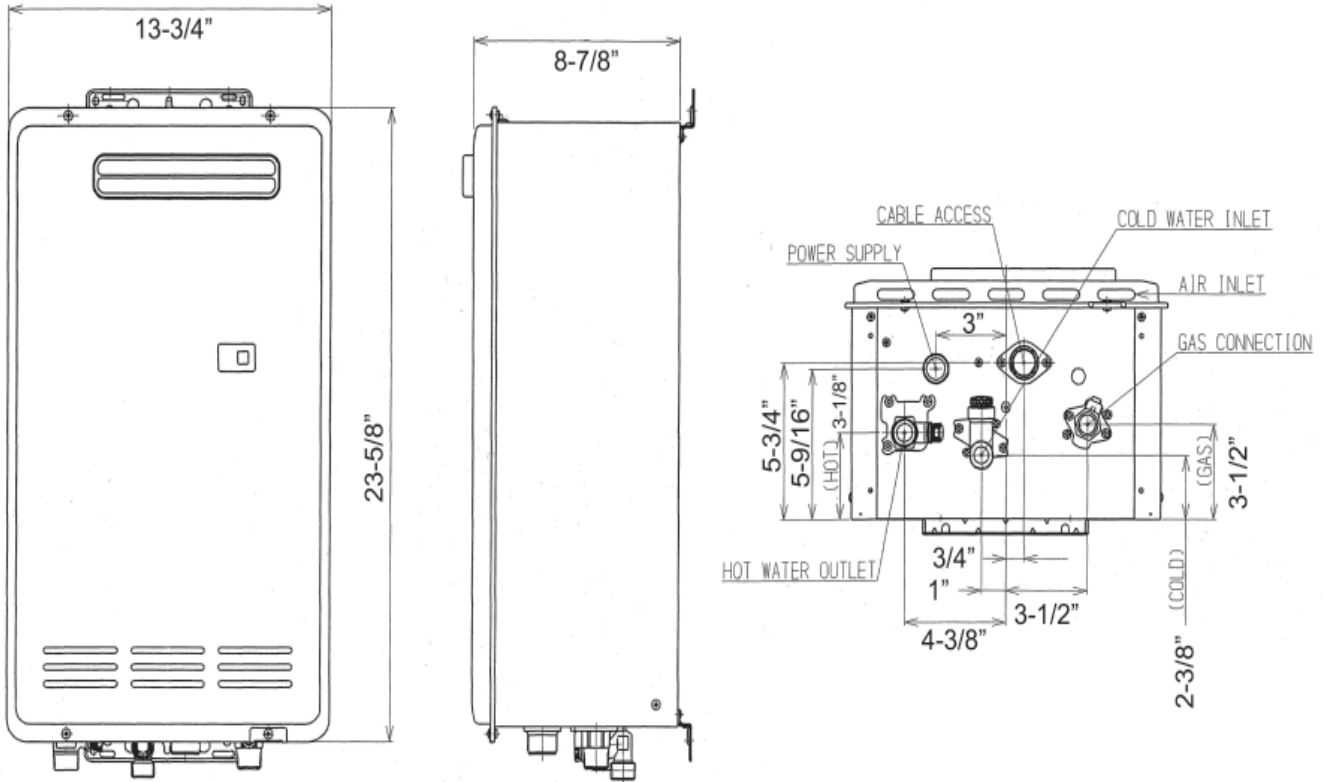

4. Installation

Piping recommendation.

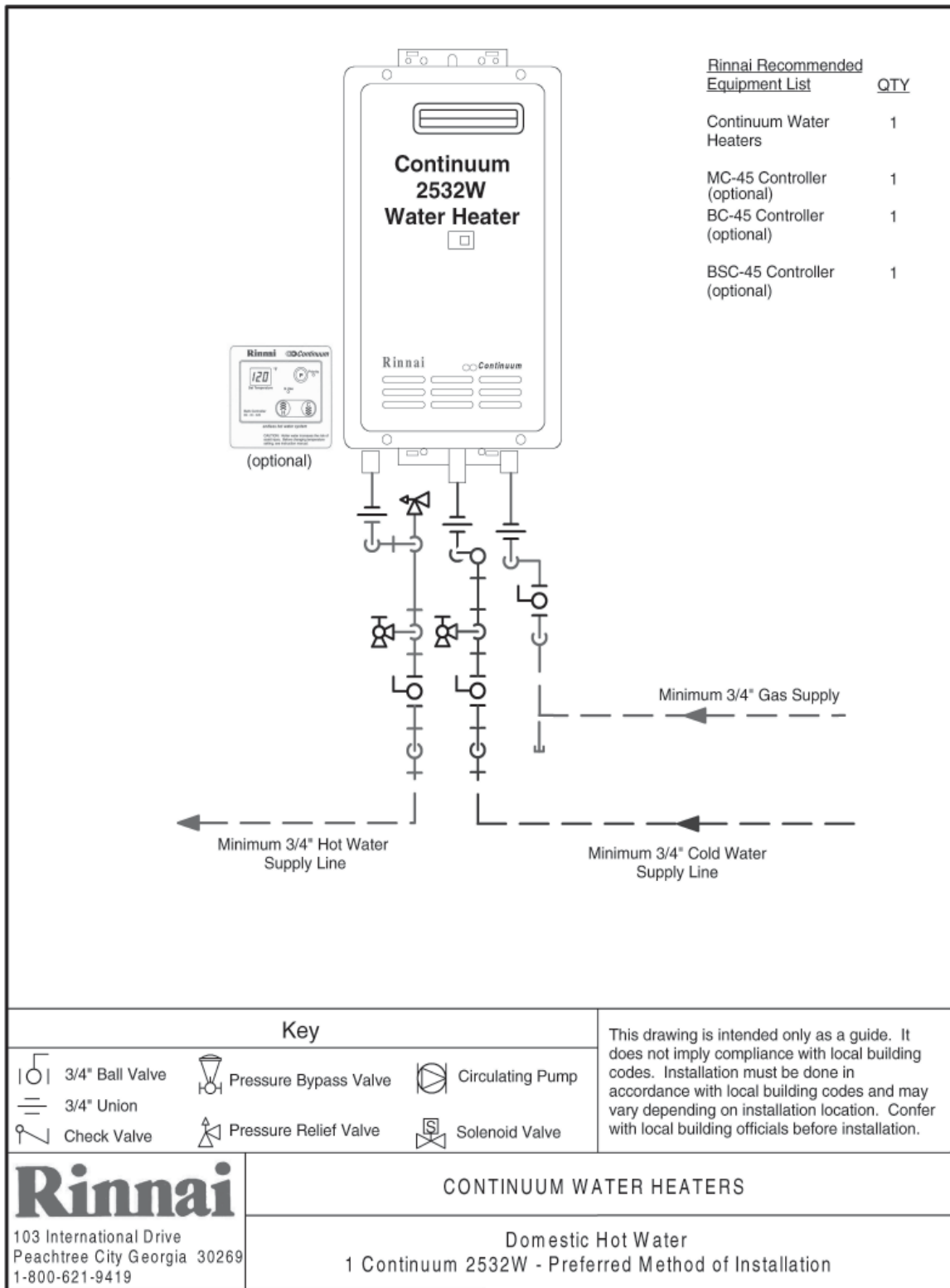

5. Remote Controls

The MC45-4US, BC45-4US, BSC45-4US , and the MCC45-4US remote key pads were specifically designed for use with the Continuum water heaters.

Features include:

- Color coordination to allow immediate recognition of the temperature “hot” and “cold” buttons.
- Large LED display. Temperature adjustments in two degree increments from 96 – 110 °F, then two five degree increments from 110 – 115 °F , and 115 °F - 120 °F , on the BC, BSC and MC controllers.
- The “MC” controller has two additional ten degree increments, from 120 to 130, and 130 to 140 °F.
- The BC, BSC and MC controls are for domestic use. The MCC control allows the temperature to be adjusted from 96°F - 180°F , this control is used only for commercial units.
- Water temperature adjustment only in the range of 96 – 110 °F while hot water is flowing. Anti-Scald feature defaults unit back to 100 °F, if remote fails or becomes disconnected while water is flowing.
- Enhanced communication system between the remote controls, allowing priority temperature selection from each remote control.
- Remote controls offer self-diagnostics in the event of a fault with the unit, simplifying service calls. To retrieve the last ten error codes press and hold the green button down, while holding this button down press the red button. This will give you a fault code history. To reset, turn the power supply off to the unit , then reapply power.
- Flashes “LC” in the event of a liming condition. To reset the “LC” mode, power must be turned off to the unit and then reapplied.
- To measure the flow rate through the unit using the remote control, press the red button and hold it down while the unit is operational, while holding the red button down press the green button. This will give you the gallons per minute flowing through the heater.
- To measure the water heater’s output water temperature press the blue button and hold it down while the unit is operational, while holding the blue button down press the green button. This will give you the water temperature being delivered by the unit.

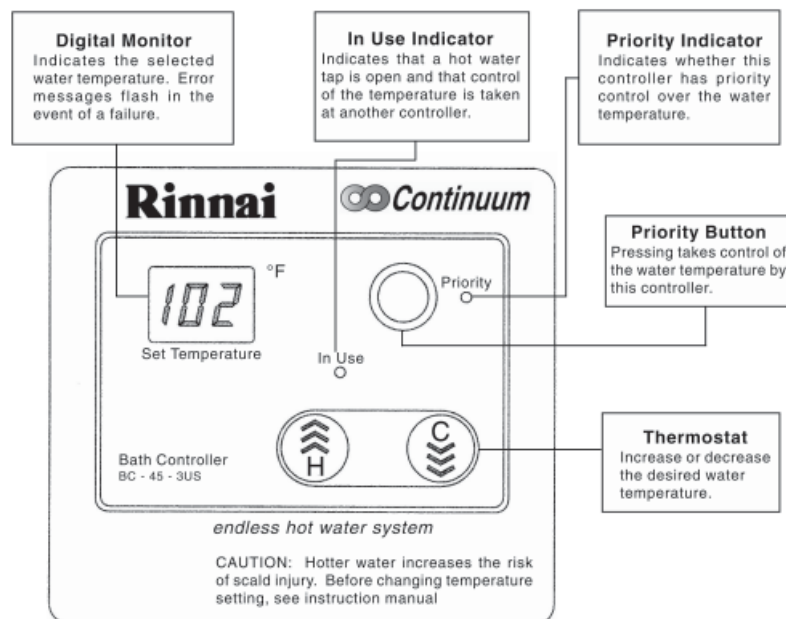

6. Suggested Connection Methods for Remotes

There must be at least one cable from the remote control(s) connected to the Continuum water heater. Power for the remote(s) is supplied from the PCB. On the front of the PCB, there are two screws labeled terminals for controls. This is the 12VDC digital power supply for the remotes. Use low voltage thermostat wire when wiring up the keypads.

Connections

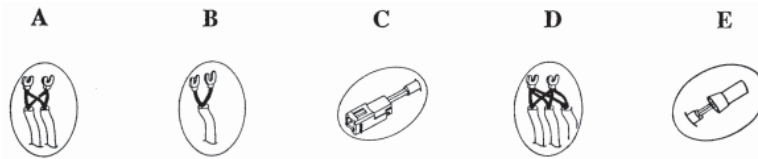

The following diagrams show methods of connection.

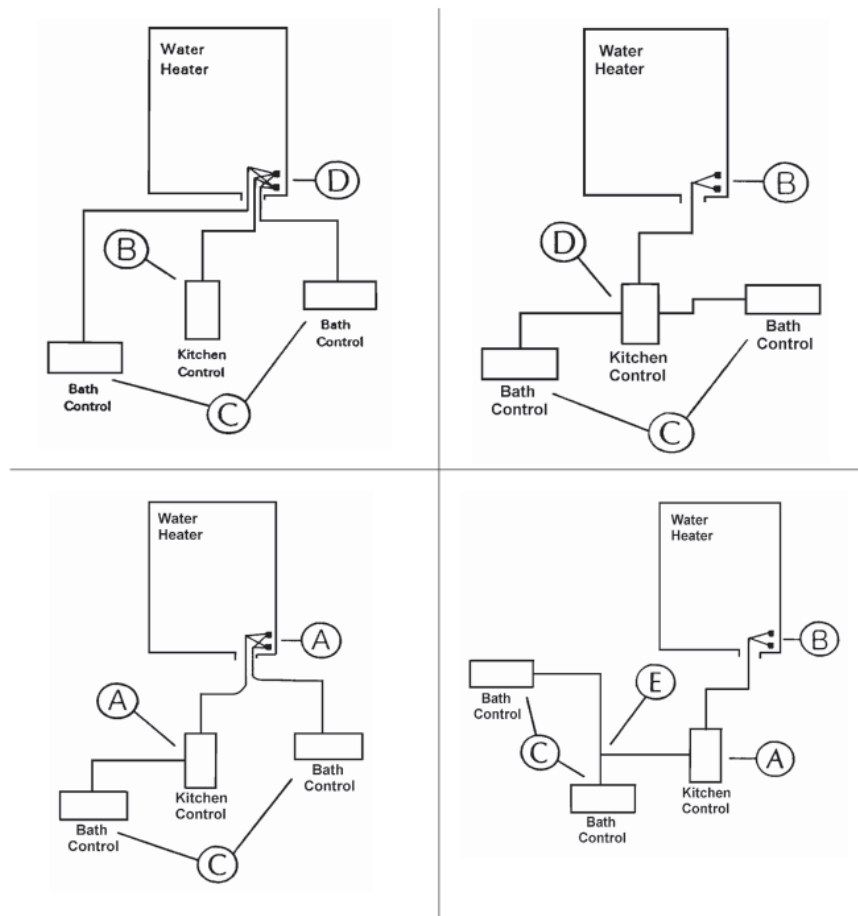

7. Safety Devices

Flame Failure

Situated to the right of the burner in the front of the combustion chamber, the flame rod monitors the combustion process. This sensor monitors the flame intensity, while the PCB compares this signal to the feed back signal from the combustion fan motor, water flow control, and gas flow through the POV valve. If any one of the feedback signals are incorrect, the unit will shut off, preventing discharge of gas to the burner.

Over Heat Protection Device

Also referred to as an Over Heat Switch. This device is fitted to a bend section at the left side of the heat exchanger. If the flame remains on to the burner after the tap is closed and the water temperature inside the heat exchanger reaches 194 ° F, a 12 volt DC bi-metal cut-off switch will shut off the gas supply to the solenoids.

No Water

Should the incoming water flow become restricted or stop, the water flow sensor will cease to send a magnetic pulse signal to the PCB, in turn preventing gas to flow into the combustion chamber. If you have restricted flow, first check to ensure the inline water filter is not clogged up.

Thermal Fuse

Wrapped around the entire surface of the heat exchanger you will find a thermal fuse. This device activates in the event the heat exchanger burns out, or the temperature outside the heat exchanger reaches 264 °F. If the thermal fuse melts, it breaks an electronic circuit which in turn shuts off the power supply to the gas solenoids, shutting the unit off.

Combustion Fan Revolution Check

The combustion fan rpm's are continually monitored by a magnetic pulse generator connected to the PCB. If the fan revolutions deviate from the speed required for complete combustion, a signal is sent to the PCB and the revolutions adjust accordingly. (If not the unit shuts down)

Automatic Frost Protection

When the temperature inside the appliance drops below 37 °F , the frost sensing device inside the appliance activates the anti-frost heaters to prevent the water inside the unit from freezing. The anti-frost heaters remain ON until the temperature inside the appliance rises to 57 °F. There are five (16) watt anti-frost heaters located at various points throughout the main water flow area of the appliance. The unit also incorporates the ability to fire for (3) seconds in the event the anti-frost heaters can not keep the water temperature from dropping below 37 °F. This unique feature will heat the water in the lines inside the appliance back up to 57 °F. ***Both of the above features function as long as the unit has power and gas.*** There is an optional freeze protection system that can be added to the unit's piping. See the auto drain down drawing in the product Owner's manual for instructions on how to install the option freeze protection in the event of a power failure in cold climates.

5 °F Over temperature Cut-Off

The temperature of the outgoing hot water is constantly monitored by the water temperature thermistor located near the outlet of the appliance. If the outgoing water temperature reaches 5 °F above the preset temperature, the burner will automatically go out. The burner will only ignite again once the outgoing hot water temperature falls below the preset temperature.

8. SPECIFICATIONS

Type of appliance	Temperature controlled continuous flow gas hot water system		
Operation	With/without remote controls		
Exhaust system	Direct Vent - Forced combustion		
Rinnai model number	REU-2532W	REU-2532W-C	
Maximum/Minimum gas rate (Input Btu's)	199,000 Btu's – 15,000 Btu's Natural gas 199,000 Btu's – 15,000 Btu's Propane Gas		
Thermal Efficiency	Natural Gas 84%.	Propane Gas 85%	
Energy Factor (EF)	Natural Gas 0.82	Propane Gas 0.84	
Capacity (Gallons 1 st . Hour @ 90 °F rise)	Natural Gas 218	Propane Gas 227	
NOx Emissions (at 3% O ₂)	Less than 40 ppm		
Hot water capacity (35°F rise)	0.5 to 8.5 GPM's		
Hot water capacity (50°F rise)	0.5 to 6.5 GPM's		
Setpoint Temperature (without remote)	Factory setting - 120°F		
Temperature range with remote keypads connected	BC-45-4US 96 - 120°F BSC-45-4US 96 - 120°F MC-45-4US 96 - 140°F	MCC-45-4US 96 - 180°F	
Approved gas type	Natural or Propane – Ensure unit matches supply gas type.		
Installation	Outdoor installation ONLY		
Dimensions	Height 23 ⁵ / ₈ "	Width 13 ³ / ₄ "	
	Depth 8 ⁷ / ₈ "		
Weight	46 Lbs.		
Noise levels	49 dB's		
Connections	Gas supply ¾" MNPT	Cold water inlet ¾" MNPT	
	Hot water outlet ¾" MNPT		
Ignition system	Direct electronic ignition		
Electrical consumption	Normal 63 watts	Standby 5.5 watts	
	Anti-frost protection 84 watts		
Water temperature control	Simulation feedforward and feedback		
Water flow control	Water flow sensor and automatic electro-mechanical water control devise		
Recommended Minimum water supply pressure	20 PSI (Rinnai recommends 50-80 PSI for maximum performance)		
Maximum water supply pressure	150 PSI		

Specifications cont.

Power Supply	Appliance – 120 Volts A.C. – 60 Hz. Remote control 12 volt D.C. (Digital)	
Safety Devices	Flame failure	
	Boiling protection	
	Remaining flame (OHS)	
	Fusible link	
	Automatic frost protection	
	Combustion fan rpm check	
	Over current	
Remote control	BC-45-4US BSC-45-4US MC-45-4US	MCC-45-4US
Remote control cable	Non-polarized two core cable	
Clearances from combustibles	Top of heater	
	Front of heater	
	Sides of heater	
	Back of heater	
	Ground	
Clearances from non combustibles	Top of heater	
	Front of heater	
	Sides of heater	
	Back of heater	
	Bottom of heater	
	Installations within RGB-25 Recess Box: Clearances from combustibles to recess box top, bottom, back and sides = 0"	
Clearances from Eaves, Porches, Overhangs	Top of heater	36"
Minimum and maximum gas supply pressure	Natural Gas: Minimum 6" W.C. (NAT.) Maximum 10.5" W.C.	
Manifold Gas Pressure		
Warranty		

9. Cut-way Diagram

REU-2532-FFU Series

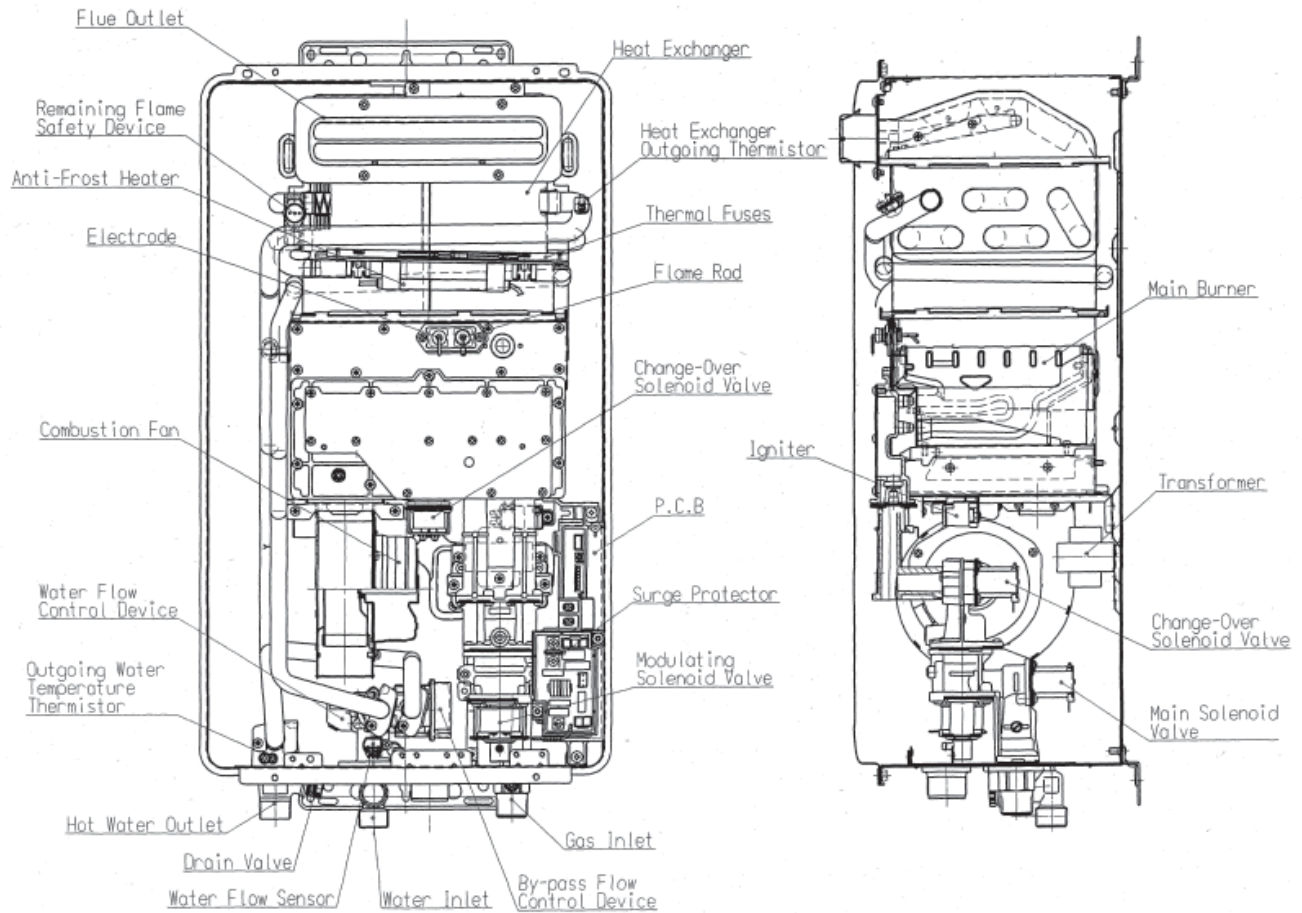

10. Schematic Diagram

REU-2532W Series

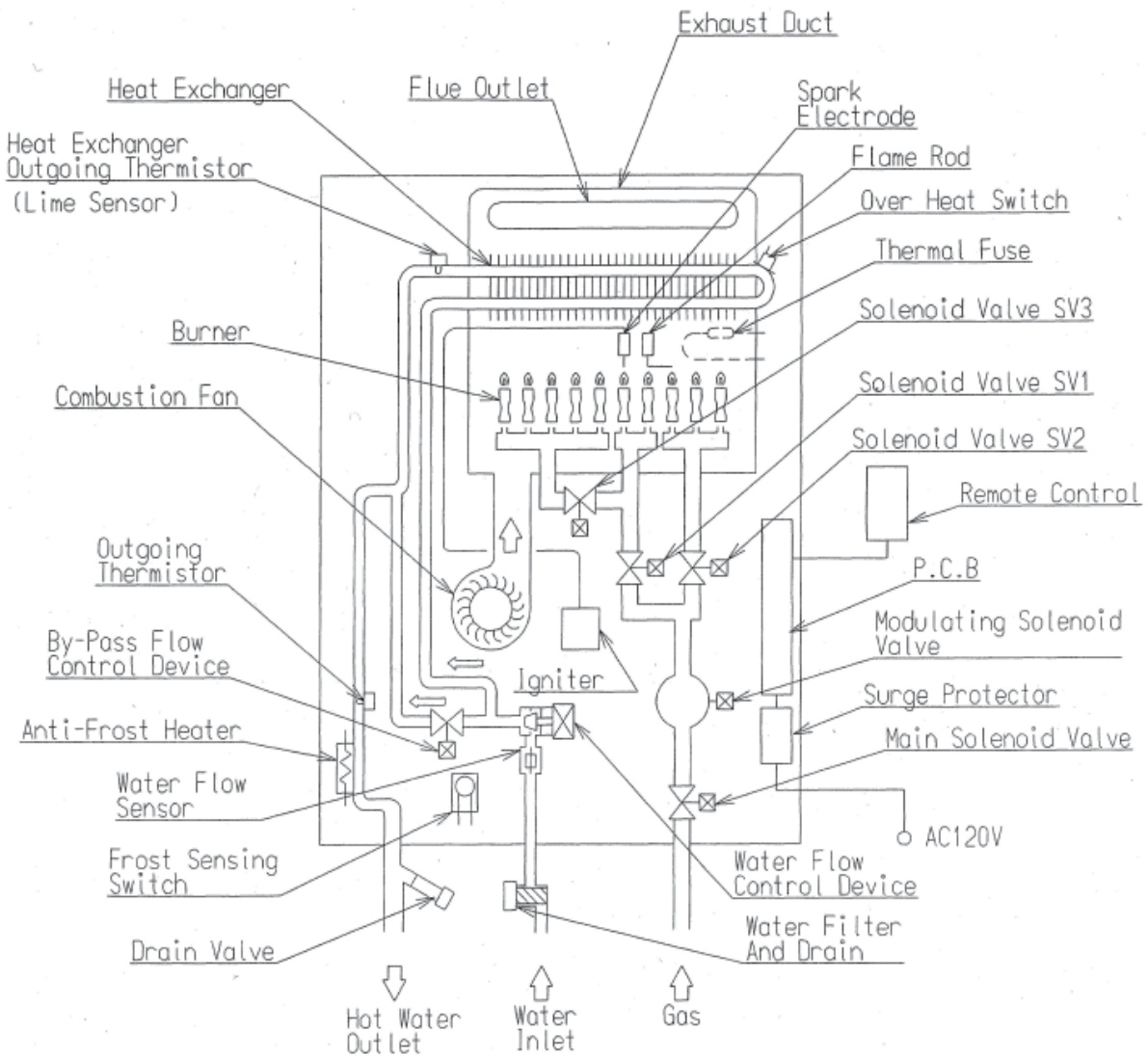

11. Combustion Specifications

Model: REU-2532W Series

Item	Gas Type	Natural	Propane
Gas consumption	Minimum Btu's	15,000	15,000
	Maximum Btu's	199,000	199,000
Injector Diameter	Upper	ø1.15	ø0.75
	Lower	ø1.8	ø1.15
Main Burner	B3A7-1 (Lean and Rich Bunsen Burner)		
Main Damper	H73-115 (Upper: Ø6, Lower: Not Used)		
Gas Pressure Supply/Manifold	Minimum Supply	6" W.C.	10" W.C.
	Maximum Supply	10.5" W.C.	13.5" W.C.
	Minimum Manifold	0.56" W.C.	0.88" W.C.
	Maximum Manifold	3.4" W.C.	5.1" W.C.

12. DIP SWITCHES

Contact Rinnai for dip switch settings when changing PC board or setting up unit for special applications. Failure to set dip switches to the proper position will result in damage to the unit, property damage, personal injury or death. DO NOT adjust dip switches unless you have written permission from Rinnai. Call 1(800)621-9419 to set-up a special training class pertaining to dip switch functions.

The dip switches on this appliance can be adjusted to deliver water temperatures from 108°F - 180°F, only for commercial type applications, and to check/reset low/high fire manifold pressures, and to set the unit up to operate on a different gas type in the event the unit was converted from one gas type to another. **In residential applications these switches should never be readjusted from the factory setting. The factory default temperature setting is 120°F.**

The set-up configuration for the water heater differs depending on:

Gas type

Maximum water flow selected

Temperature limiting requirements

Application type

“SW1” row of dip switches

1. Not Used
2. Fixed water temperature with or without remote.
3. To select a desired water temperature for commercial applications
4. To select a desired water temperature for commercial applications
5. To select a desired water temperature for commercial applications
6. Flow switch activated or de-activated and temperature selection for commercial applications.
7. Combustion control (Forced low fire).
8. Combustion control (Forced high fire).

Combustion control switches are used to set or check the manifold gas pressures on this appliance. When dip switch #7 is placed in the “ON” position, it places the appliance into forced low fire. When dip switches #7 and #8 are placed in the “ON” position, it places the unit into forced high fire. **Before placing the unit into forced low or high fire, you MUST ensure you have maximum water flow through the appliance. Open several faucets throughout the residence before proceeding. After checking or setting manifold gas pressures, dip switches 7 and 8 MUST be placed in the “OFF” position, to return the appliance to a normal operating mode. Failure to place these switches to the “OFF” position will cause the unit to mal-function.**

The REU-2532 series water heaters comes from the factory set to deliver a water temperature of 120 °F, the REU-2532-C series is set to deliver 120°F. However, the commercial series will allow water temperature adjustments up to 180°F for applications such as; hotels, car washes, laundry mats, hospitals, farms, processing plants, etc., that require water temperatures above 120°F. **Temperatures above 120 °F are not recommended due to burn hazards. Please use extreme caution if adjusting water temperatures above 120 °F.**

Explanation of “SW1” Dip Switches;

(Switch #1) at SW1” row of switches comes from the factory in the “OFF” position. This switch presently is not used.

(Switch #2) Fixed Water Temperature with or without Remote. When this switch is set to the “OFF” position, switches 3 – 6 can be adjusted to a pre-determined position that will not allow the remote pad to be adjusted above a selected temperature. When set to the “ON” position and no keypad is being used, the unit can be set to deliver a set temperature from 108, 120, 130, etc. **DO NOT make adjustments without written permission from Rinnai.**

(Switches 3,4, & 5) Temperature Adjustment Switches. Switches #3, 4, and 5 are used to set fixed temperatures with or without the remote keypads. Contact Rinnai for dip switch settings when changing the unit's PC board or setting up special applications. **Failure to set dip switches to the proper position will result in damage to the unit, property damage, personal injury or death. DO NOT, adjust switches unless you have written permission directly from Rinnai. Call 1(800)621-9419** to set-up a special training class pertaining to dip switch functions.

(Switch #6) Flow Switch and Temperature Adjustments. Rinnai offers a flow switch that can serve as an anti-scald device. This switch is installed in-line with each bathroom. Therefore, if someone was using water above 120°F and a tap was turned on in one of the bathrooms, the unit would automatically default back to 120°F to prevent scalding. When dip switch #6 is set to the “ON” position this function is activated. At the present time this switch is not used in the U.S. market, due to anti-scald devices and/or pressure balancing valves presently being used in our market.

(Switches 7& 8) Low/High Fire Combustion Control Switches. Dip switch # 7 is used to place the unit into forced low fire when checking and/or setting manifold gas pressures. Dip switch #7 and #8 are used to place the appliance into forced high fire. Before making any adjustments to these switches, please ensure you follow the gas pressure setting procedure found in this manual.

“SW2” row of Dip Switches

1. Gas type (Used only when replacing PCB or converting unit)
2. Lime control switch activated or de-activated.
3. Plus three degrees or plus six degrees differential.
4. Type of unit. (Residential or commercial)

(SW2) Explanation of SW2 row of Dip Switches

(Switch #1) Gas Type Switch. When set to the “OFF” position the unit is setup to operate on propane gas, in the “ON” position it is setup for natural gas.

(Switch #2) Lime Control Switch. Set dip switch #2 to the “OFF” position to activate the lime control function. To deactivate this function place this switch in the “ON” position.

(#3) Temperature Differential Switch. The temperature of the outgoing water is constantly monitored by the outlet temperature thermistor. If the outlet water temperature rises to more than 5.4°F above the preset temperature, the burner will automatically go out when dip switch #3 is in the “OFF” position. The burner will ignite again once the outlet water temperature falls below the preset temperature. If this switch is set to the “ON” position it will allow a 10.8 °F rise.

(Switch #4) Type of Unit. Danger; do not adjust this dip switch. **Adjusting this will result in damage to the unit, property damage, personal injury or death.**

Rinnai Continuum and Integrity Water Heaters Dip Switch Default Settings

The settings below are factory default settings. Please ensure the model number and gas type of the unit you have, matches the model number and gas type listed below; before settings any switches. If you need assistance, contact Rinnai at (800)621-9419 before proceeding.

Residential Units

REU-2532-W

Propane Gas Model

Dip Switch Settings:

(SW1)

#1 = Off

#2 = On

#3 = Off

#4 = Off

#5 = Off

#6 = Off

#7 = Off

#8 = Off

(SW2)

#1 = Off

#2 = Off

#3 = Off

#4 = Off

Residential Units

REU-2532-W

Natural Gas Model

Dip Switch Settings:

(SW1)

#1 = Off

#2 = On

#3 = Off

#4 = Off

#5 = Off

#6 = Off

#7 = Off

#8 = Off

(SW2)

#1 = On

#2 = Off

#3 = Off

#4 = Off

Commercial Units

REU-2532-WC

Propane Gas Model

Dip Switch Settings:

(SW1)

#1 = Off

#2 = On

#3 = Off

#4 = Off

#5 = Off

#6 = Off

#7 = Off

#8 = Off

(SW2)

#1 = Off

#2 = Off

#3 = Off

#4 = On

Commercial Units

REU-2532-WC

Natural Gas Model

Dip Switch Settings:

(SW1)

#1 = Off

#2 = On

#3 = Off

#4 = Off

#5 = Off

#6 = Off

#7 = Off

#8 = Off

(SW2)

#1 = On

#2 = Off

#3 = Off

#4 = On

13. Water Flows

A simple calculation of the water flow rate, in gallons per minute, can be made using the chart on the next page, or simply using formula provided below. The chart on the following page indicates the water flow from the Continuum at various temperature rises up to a 140 degree rise.

a. How to read the charts:

The vertical plane indicates water flow in gallons per minute, and the horizontal plane indicates the temperature rise. The chart shows flow rates up to a 140 degree rise. Therefore, the water flow chart can be used to help you size your applications, if you know the temperature rise needed. The temperature rise is the difference between the temperature of the incoming water and the selected temperature at the remote control(s). Another name used in place of temperature rise, is delta T.

Select the appropriate temperature rise. Draw a vertical line up the graph from the selected temperature rise until it intersects the curve. The point at where these lines intersect indicates flow at that temperature rise.

b. How to calculate water flows:

The following information is an outline of the formula required to measure accurately the flow rate in gallons per minute, as well as being the base for the chart on the next page. The formula below can be utilized when you know the following information, the Btu's and efficiency of the appliance, and the delta T you are dealing with. If this information is known follow the example below to determine your flow rate. The example below assumes the appliance's Btu rating is 180,000, the efficiency is .82 and the delta T is 55 degrees.

EXAMPLE:

$$\text{BTU's} \div \text{AT} \times 500 = \text{GPM's}$$

$$\text{GPM's} = (180,000 \text{ BTU's} \times .82 \text{ efficiency rating}) \div \Delta T \times 500$$

$$\text{GPM's} = 147,600 \div (\text{Requested water temperature} - \text{incoming water temperature}) \times 500$$

$$\text{GPM's} = 147,600 \div (120 \text{ }^\circ\text{F requested} - 65 \text{ }^\circ\text{F incoming}) \times 500$$

$$\text{GPM's} = 147,600 \div (55 \text{ }^\circ\text{F delta T} \times 500)$$

$$\text{GPM's} = 147,600 \div 27,500$$

$$\text{GPM's} = 5.367$$

Unmixed Water Flows for REU-2532 Series

The chart below can be used to determine water flow rates in “gallons per minute” at a given temperature rise. In order to figure flow rates, you need the following information; requested water temperature and inlet water temperature. Next, subtract the inlet water temperature from the requested temperature to get your delta T or temperature rise. Then, locate your temperature rise at the bottom of the chart. Follow that line vertically until it intersects with the flow rate line to the left. This indicates the flow rate at your temperature rise.

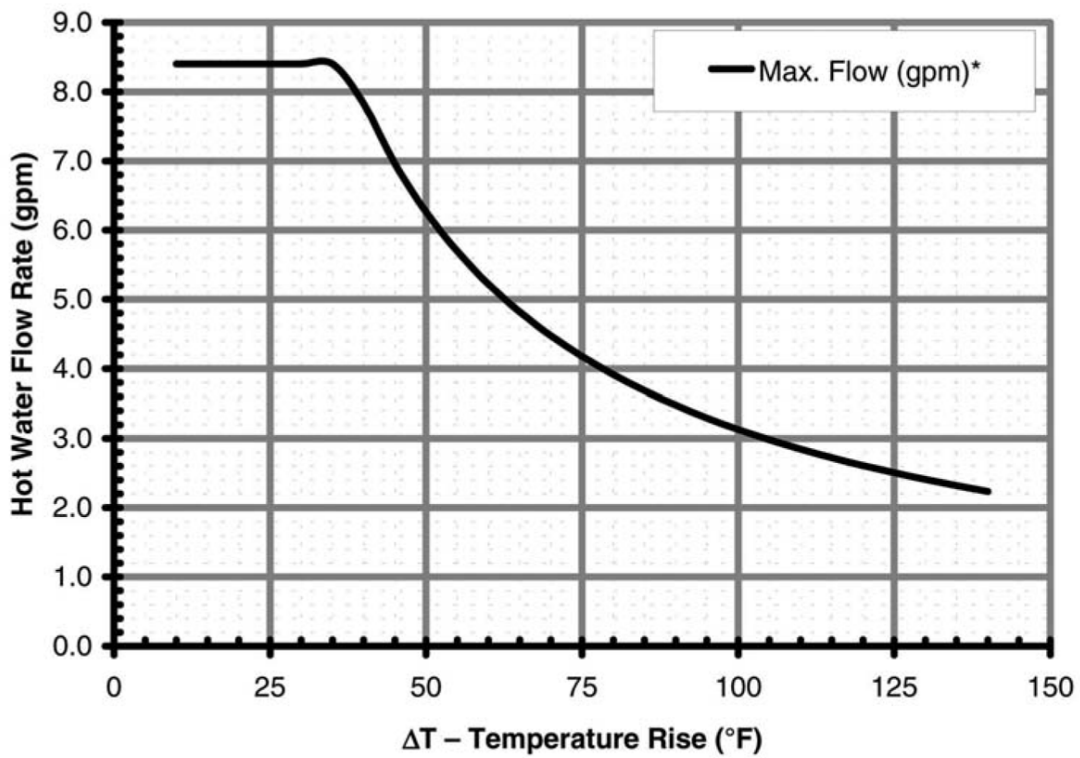

14. Main Components

1. Mechanical Water Regulator

Rinnai's unique water regulator mechanism ensures the hot water is maintained with no noticeable change to the desired temperature during use, even if water pressure drops due to another tap being turned on and increasing the demand.

The following graph shows that maximum flow is approximately 8.5 gallons per minute for the Continuum. This maximum flow is reached at 29 PSI inlet pressure respectively.

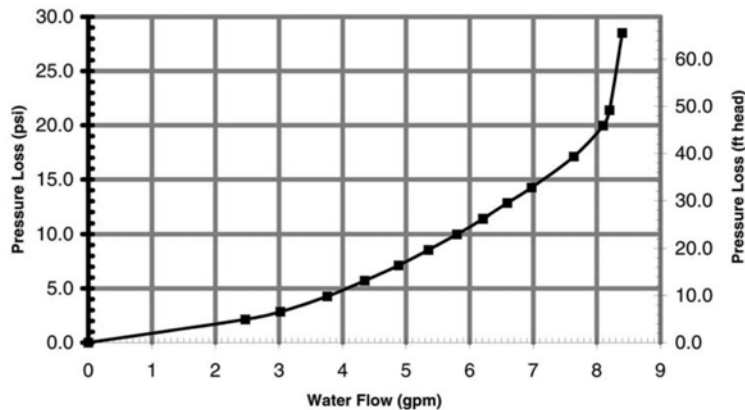

2. Preset Bypass

A preset volume of cold water is mixed with water heated in the heat exchanger.

3. Burner

The burner assembly is made up of 16 identical stainless steel Bunsen burners, secured by an aluminized steel framework. An aluminum manifold with 32 integral injectors supplies gas to the burners, and is attached to the front lower cover of the burner box and gas control assembly.

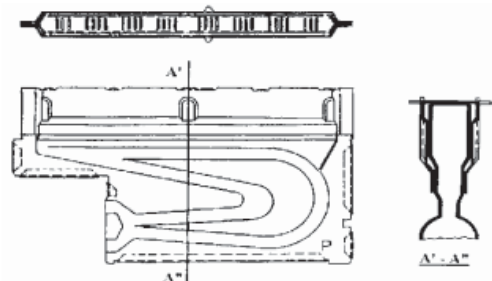

4. Gas Control Valve

The gas control valve uses four solenoids to fully modulate within four different input ranges to respond quickly and accurately to changes in water flow rate. The four ranges are as follows: up to 18% of total btu's (using three burners), up to 33% (using five burners), up to 50% (using eight burners), and up to 100% (using sixteen burners) This increases the flexibility of the regulator/modulating valve by supplying gas equally to each burners.

5. Combustion Fan

Air for the combustion is supplied by a centrifugal fan driven by a DC motor. After a pre-purge period of 0.2 seconds, the fan speed is controlled by the PCB to provide the correct volume of air for combustion. The calculation for the fan speed is based upon incoming water temperature, water flow and the temperature selected on the remote controls.

The actual speed of the motor is continuously monitored by a magnetic pulse sensor.

This sensor emits (4) pulses per rotation of the fan. This is the fan feedback or confirmation data processed by the PCB.

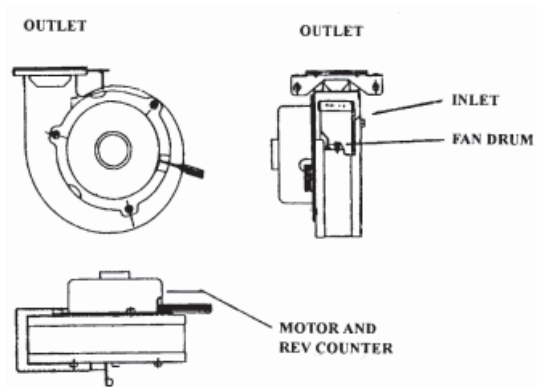

1. The fan speed is constantly correcting to provide optimum combustion conditions.
2. To determine the opening degree of the modulating gas valve, so that the gas rate always matches the volume of air for combustion, as well as the input required to heat the water.

The reason for controlling the opening degree of the modulating gas valve based upon data from the combustion fan is that, the gas valve is able to react much more quickly to a change in control signal than the combustion fan is. Controlling the gas valve based upon data from the combustion fan means that combustion remains satisfactory, even if there are sudden changes in input conditions.

1. Water Flow Sensor and Water Flow Control device

Water flow is detected by a turbine/magnetic pulse generating device. Water flows through the turbine/magnetic sensor providing information to the PCB by generating a pre-determined number of pulses in proportion to the water flow. These pulses are counted by the PCB – no pulse indicates no water flow. The frequency of the magnetic pulses increases as the water flow increases, this enables the PCB to calculate the exact water flow, and determine the water flow in gallons per minute. As soon as the required water flow is detected, the PCB activates the combustion fan. The combustion fan speed is monitored by a magnetic pulse sensor. The output from this sensor is processed by the PCB which opens the gas modulating valve to a degree proportional to the fan speed. See above for further details on the combustion fan.

The water flow control consists of a plug and barrel valve which is rotated by a motor to increase or decrease the volume of water passing through the heat exchanger.

REU-2532 units have an automatic water flow control device.

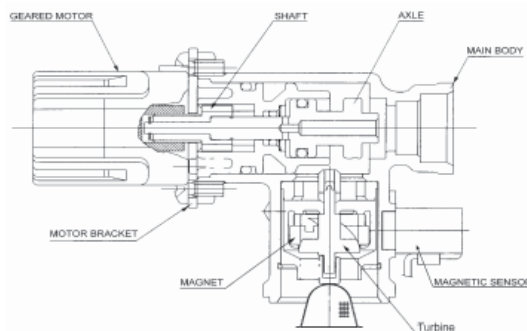

15. Time Charts (External Unit)

NORMAL COMBUSTION SEQUENCE

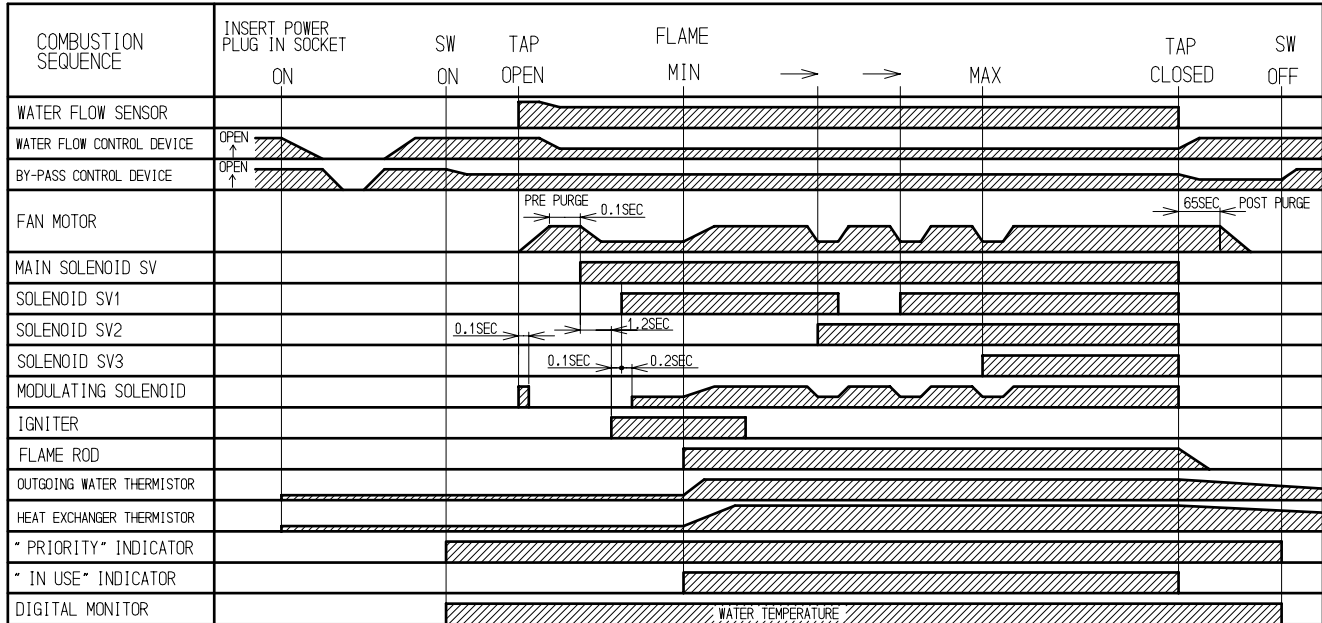

ERROR SEQUENCE (IGNITION/FLAME FAILURE)

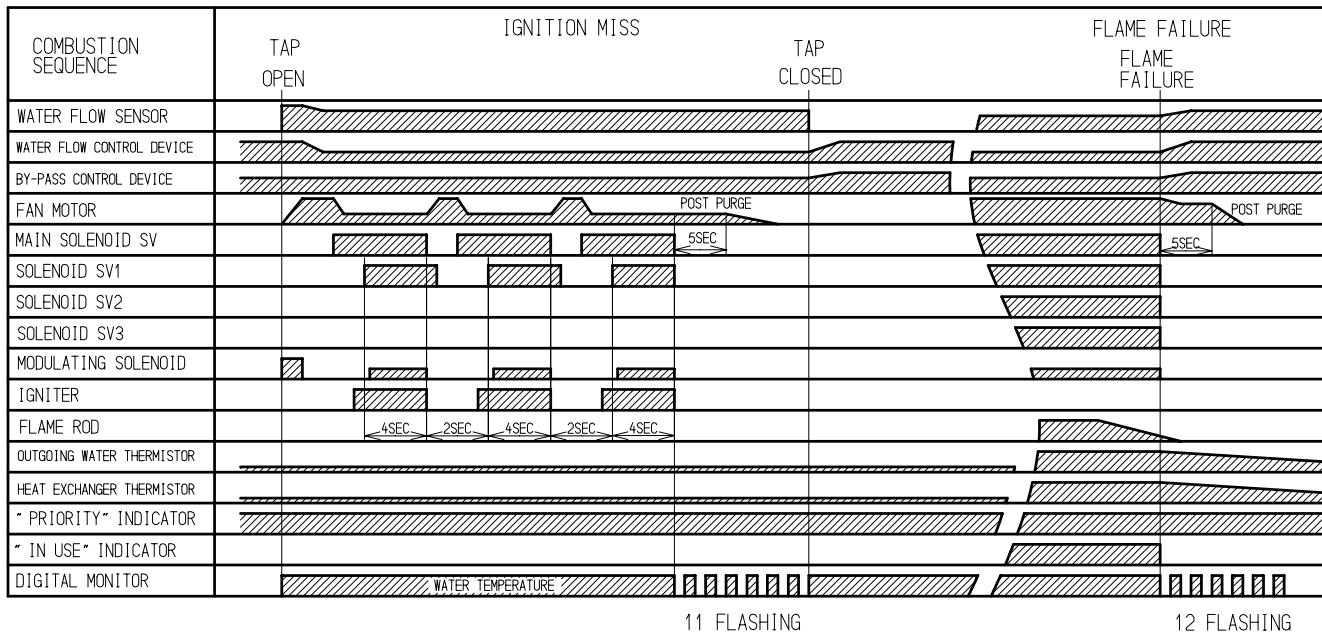

PRE PURGE DEFECT SEQUENCE

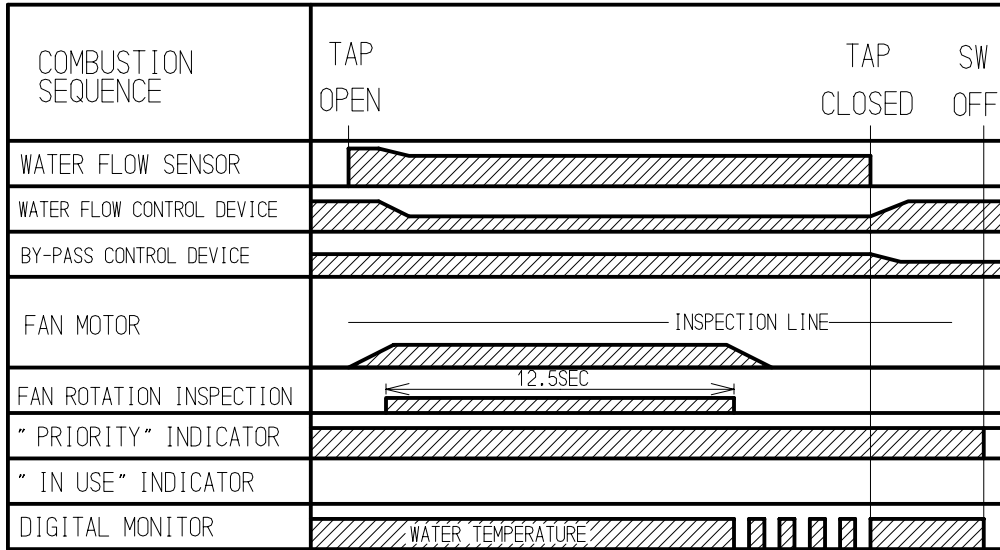

61FLASHING

16. Operation Flow Principle

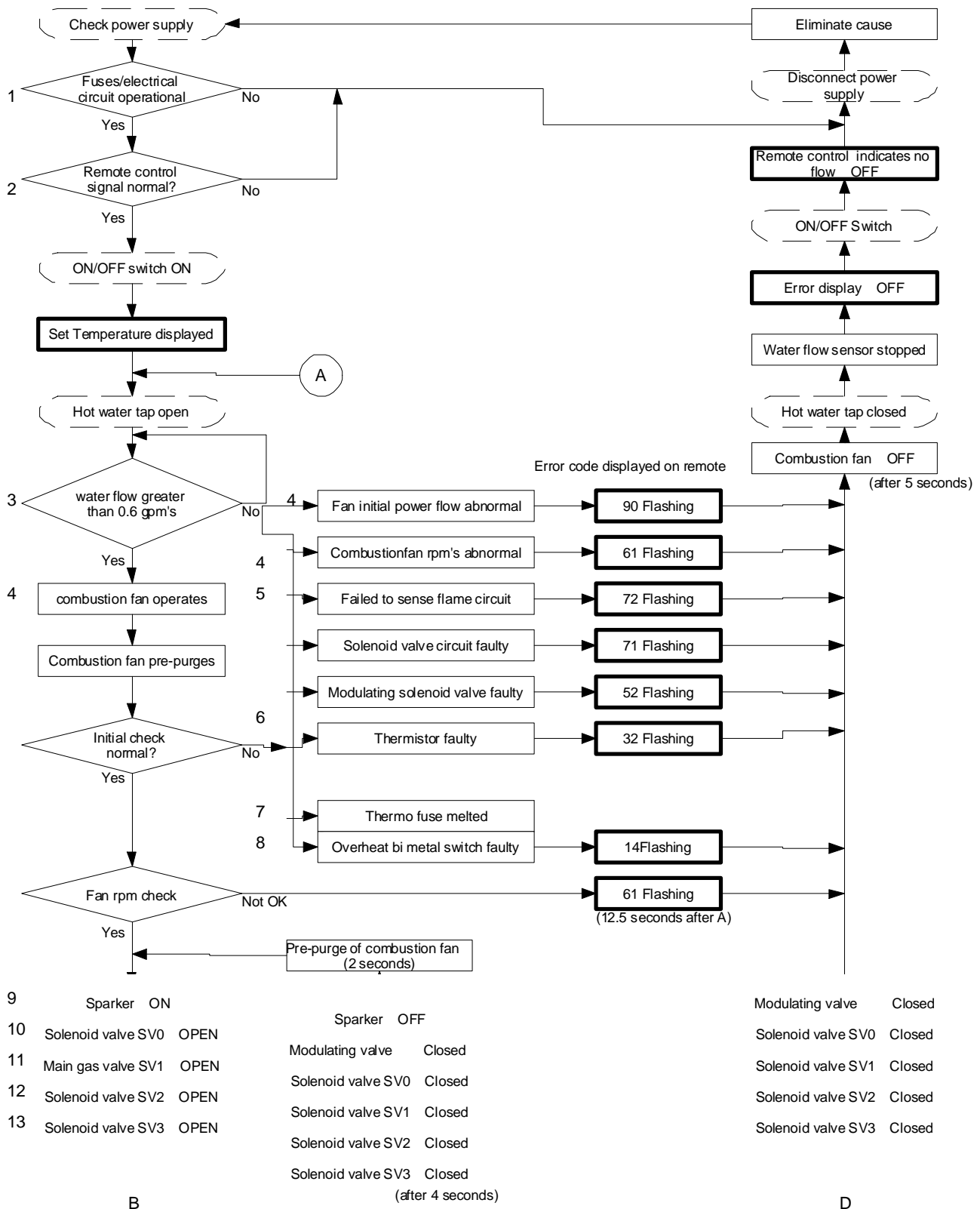

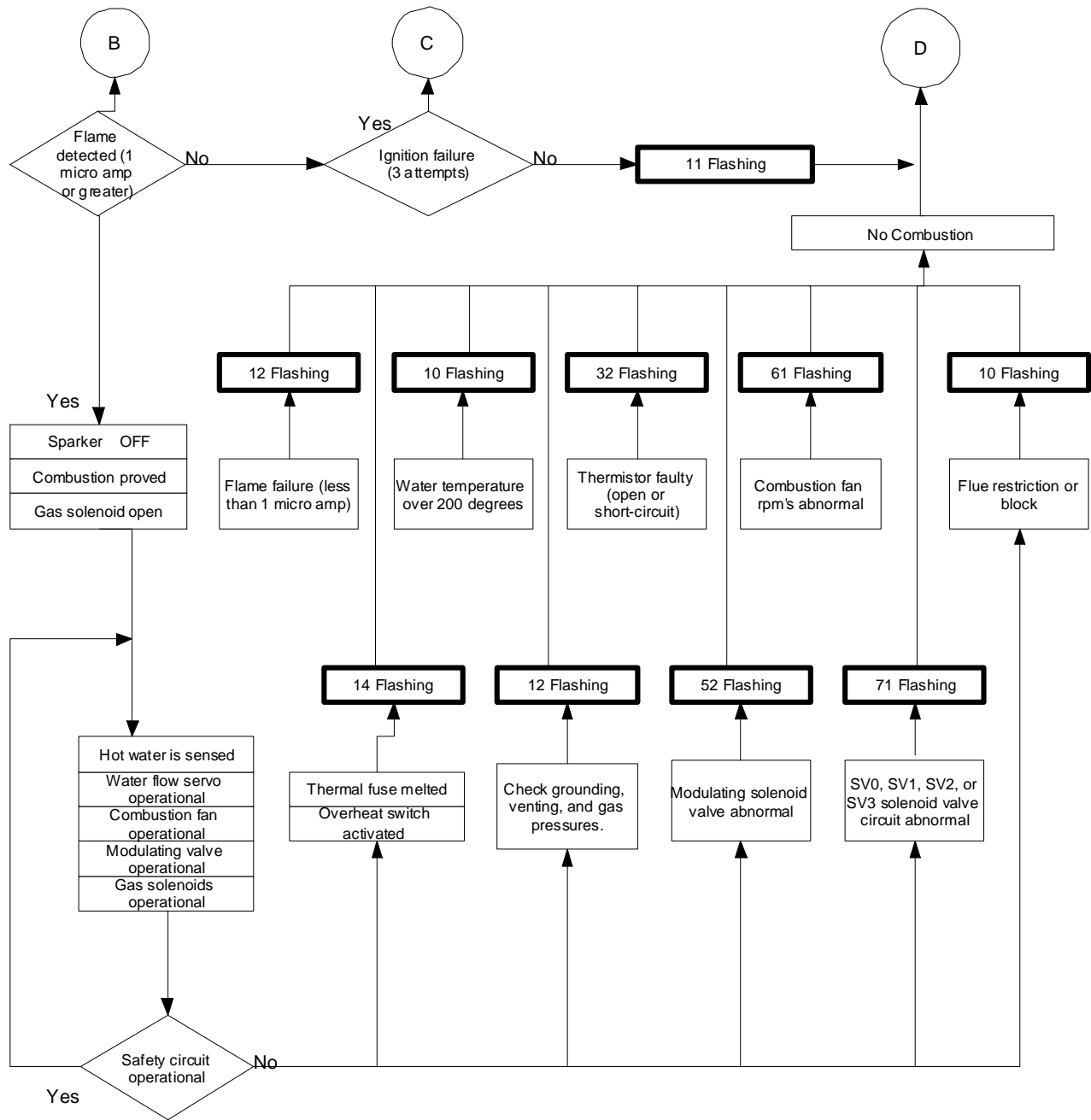

17. Operation Principles

The preset temperature is selected at one of the remotes controls (where fitted). Where no remote control is fitted, the default temperature can be set at 108, 120, 130, 140, 150, 160, 170, or 180 °F. To select one of the above temperatures as your default setting, you **MUST** obtain written permission and training from Rinnai. This function may not be allowed at temperatures above 120°F for safety reasons.

When the unit is first plugged into 120 volts, the PCB assumes an incoming water temperature of 77 °F. This prevents the appliance from starting in “High fire” and producing very hot water the first time it is used.

The data used to determine the outgoing water temperature, initially, is incoming water flow and the remote control pre-set temperature.

From the incoming water flow and remote control pre-set temperature data, the CPU is able to determine a suitable gas rate to kick the appliance off once a hot water tap opens.

The calculation of temperature rise and water flow is called simulation feed-forward.

The water heater calculates incoming water temperature by subtracting the theoretical temperature rise from the outgoing hot water temperature to establish the correct gas flow.

When a hot water tap is opened, water begins to flow through the appliance. The turbine in the water flow sensor begins to revolve. The revolution speed is proportional to the heater flow. A sensor located inside the device relays information in the form of magnetic pulses to the main PCB to determine whether or not water is flowing, and also, the volume of water flowing. When a predetermined water flow is sensed, the ignition sequence begins.

The combustion fan pre-purges the combustion chamber. A rev counter on the combustion fan indicates the fan rpm to the main PCB. Once the pre-purge cycle is completed, the PCB controls the fan rpm by varying the DC voltage to the fan motor. This maintains the correct air/gas ratio throughout the time the water heater is in use and ensures good combustion.

The gas is ignited by direct electronic spark and the flame is sensed by the flame rod. The opening degree of the modulating valve is determined by the combustion fan speed.

The changeover valve directs gas to one side or both sides of the burner. At the point where the changeover valve opens or closes the modulating valve is instantly re-adjusted by the PCB to compensate for the change in the number of burners in use. From the information provided by the water flow sensor and the water temperature thermistor, the PCB determines how much gas is required to heat the water to the temperature selected on the remote control.

The PCB is programmed to provide the maximum volume of water possible at a given temperature rise. As the water flow from the tap is increased, the PCB increases the gas and air flow to the burner.

When the hot water tap is turned off, the water flow sensor stops revolving, and the magnetic pulse ceases, indicating to the PCB that there is no water flowing, in turn the PCB closes the gas valves. The combustion fan continues to operate for 65 seconds. This is to provide quicker ignition when the tap is turned on and off in rapid succession, as it removes the need for a pre-purge cycle and allows the burner to re-light immediately when a hot water tap is opened again.

18. Error Codes

Error	Faulty	Remedy
10	Air Supply or Exhaust Blockage	<p>Check intake and exhaust ports for obstructions.</p> <p>Check that nothing is blocking the flue inlet or exhaust.</p> <p>Did you maintain the proper clearance from combustibles around the unit?</p>
11	No Ignition	<p>Ensure you have gas to the appliance.</p> <p>Ensure gas type and pressure is correct.</p> <p>Bleed all air from gas lines.</p> <p>Verify dip switches are set properly.</p> <p>Disconnect all MSA controls.</p> <p>Ensure gas line, meter, and/or regulator is sized properly.</p> <p>Ensure appliance is properly grounded.</p> <p>Check gas solenoid valves for open or short circuits.</p> <p>Ensure igniter is operational.</p> <p>Check igniter wiring harness for damage.</p>
12	Flame Failure	<p>Ensure you have gas to the appliance.</p> <p>Ensure gas type and pressure is correct.</p> <p>Bleed all air from gas lines.</p> <p>Verify dip switches are set properly.</p> <p>Ensure flame rod wire is connected.</p> <p>Check flame rod for carbon build-up.</p> <p>Ensure gas line, meter, and/or regulator is sized properly.</p> <p>Ensure appliance is properly grounded.</p> <p>Check gas solenoid valves for open or short circuits.</p> <p>Check power supply for loose connections.</p> <p>Check power supply for proper voltage and voltage drops.</p> <p>Disconnect all MSA controls.</p> <p>Disconnect keypad.</p> <p>Disconnect and re-connect all wiring harnesses on unit and PC board.</p> <p>Immediate code 12 usually indicates a defective gas valve or power supply problem.</p>
14	Thermo Fuse	<p>Ensure dip switches are set to the proper position.</p> <p>Ensure high fire and low fire manifold pressure is correct.</p> <p>Check gas type of unit and ensure it matches gas type being used.</p> <p>Check heat exchanger for cracks and/or separations.</p> <p>Ohm out safety circuit.</p> <p>Check for improper conversion of product.</p> <p>Check for restrictions in air flow around unit and vent terminal.</p> <p>Check for a low flow circulating system that is causing the unit to short cycle.</p> <p>Check for a foreign materials in combustion chamber and/or exhaust piping.</p>
16	Over Temperature Warning	<p>Check for clogged heat exchanger.</p> <p>Check for restrictions in air flow around unit and vent terminal.</p> <p>Check for a low flow circulating system that is causing the unit to short cycle.</p> <p>Check for a foreign materials in combustion chamber and/or exhaust.</p>

32	Outgoing Water Temperature Sensor Faulty	Check sensor wiring for damage. Ohm out sensor Check and clean scale from sensor. Replace sensor.
33	Heat Exchanger Outgoing Temperature Sensor Faulty	Check sensor wiring for damage. Ohm out sensor Check and clean scale from sensor. Replace sensor.
34	Combustion Air Temperature Sensor Faulty	Check sensor wiring for damage. Ohm out sensor Check and clean scale from sensor. Ensure fan blade is tight on motor shaft and it is in good condition. Check for restrictions in air flow around unit and vent terminal. Replace sensor.
52	Modulating Solenoid Valve Answer Abnormal	Check modulating gas solenoid valve wiring harness for loose or damage terminals. Ohm out solenoid valve.
61	Combustion Fan Failure	Ensure fan motor will turn freely. Motor will operate with a small amount of restriction. Check wiring harness to motor for damaged and/or loose connections. Ohm out motor winding.
71	SV0, SV1, SV2, and SV3 Solenoid Valve Circuit Faulty	Check wiring harness to all solenoids for damage and/or loose connections. Ohm out each solenoid.
72	Flame Sensing Device Faulty	Check micro amps produced by flame rod. Remove flame rod and check for carbon build-up, clean with sand paper. Ensure flame rod is touching flame when unit fires. Check inside burner chamber for any foreign material blocking flame at flame rod. Check all wiring to flame rod for damage. Replace flame rod.
LC	Scale Build-up in Heat Exchanger	Turn off power supply, then reapply power; if code does not reappear separate control wires from the unit's power supply. Flush heat exchanger. Replace heat exchanger.
No code	Nothing happens when water flow is activated.	Clean inlet water supply filter. Ensure you have at least the minimum flow rate required to fire unit. Check for pipe dope inside water flow control turbine. On new installations ensure hot and cold water lines are not crossed. Check for bleed over. Isolate unit from building by turning off hot water line to building. Then open your pressure relief valve, if unit fires, there's a bleed over in your plumbing. If a circulating system is in use, it must be isolated also. Remote control does not light up but you have 12 VDC at the terminals for controls. Disconnect water flow control motor, then turn on hot water, if unit fires replace water flow control assembly.

19. Diagnostic Points

Flow Chart is on page #28

Wiring Diagram is on page #35



Component	Measurement Point		Normal Value	Notes
	Comp. No.	Wire Color		
Surge Protector	F ₇	Blue - Brown	AC 108 - 132 V	
Water Flow Control Device	B ₂	Red-Blue	DC 11 - 13 V	Power Supplied to Unit
		Gray-Orange	DC 11 - 13 V	Power Supplied to Unit
		Gray-Yellow	Below DC 1 V (Limiter On)	Full Open Position
			DC 4 - 6 V (Limiter Off)	
		Gray-Brown	Below DC 1 V (Limiter On)	Full Close Position
DC 4 - 6 V (Limiter Off)				
By-pass Flow Control Device	G ₁	Brown-White Orange-White Yellow-White Red-White Gnd	DC 2 - 6 V	Unit In Operating Mode
			15 - 35 kΩ	
Remote Control	D ₁	Black-Black	DC 11 - 13 V	
Water Flow Sensor	B ₄	Red - Black	DC 11 - 13 V	On 0.82 gal/min (30 Hz) Over 1800 pulse/min
		Yellow - Black Gnd	DC 4 - 7 V (Pulse 17-460 Hz)	Off 0.6 gal/min (20 Hz) Below 1200 pulse/min
Combustion Fan	A ₁	Red-Black	DC 6 - 45 V	
		Yellow-Black	DC 11 - 13 V	
		White-Black Gnd	DC 6 - 45 V (33-400 Hz)	
Flame Rod	C ₁	Yellow-Gnd	AC 5 - 150 V	After Ignition
		Yellow-Flame Rod	Over DC 1 μA	Flame Condition
Modulating Valve	C ₂	Pink-Pink	DC 2 - 15 V 67 - 81 Ω	
Outgoing Thermistor	B ₅	White-White	59°F 11.4 - 14.0 KΩ	
Heat Exchanger	B ₆		86°F 6.4 - 7.8 KΩ	
Outgoing Thermistor			113°F 3.6 - 4.5 KΩ	
Air Thermistor	B ₁		140°F 2.2 - 2.7 KΩ	
Thermal Fuse	B ₃ C ₃	Red-Red	Below 1Ω	
Ignitor	F ₆	Gray-Gray	AC 90 - 110 V	
Main Solenoid Valve	E ₁	Pink - Black	DC 80 - 100 V 1.7 - 2.1 KΩ	
Solenoid Valve 1	E ₂	Yellow - Black	DC 80 - 100 V 1.7 - 2.1 KΩ	
Solenoid Valve 2	E ₃	Blue-Black	DC 80 - 100 V 1.7 - 2.1 KΩ	
Solenoid Valve 3	E ₄	Brown - Black	DC 80 - 100 V 1.7 - 2.0 KΩ	
TRANSFORMER VOLTAGES AND RESISTANCES				
Primary Windings	F ₇	Blue-Brown	51 - 63 Ω	
Secondary Windings	F ₉	White-Black	AC 90 - 110 V	

20. REU-2532W Series Wiring

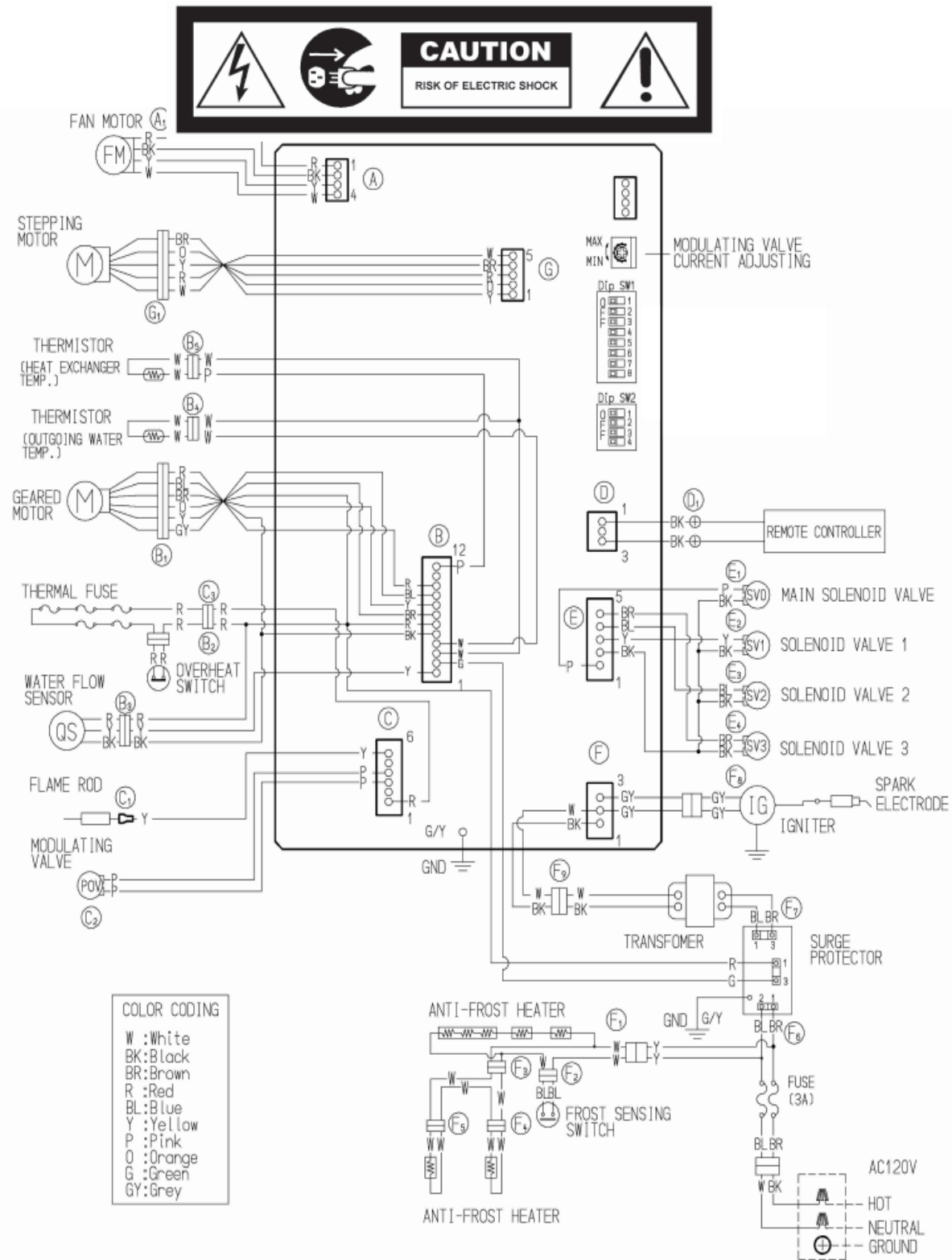

21. Block Diagram

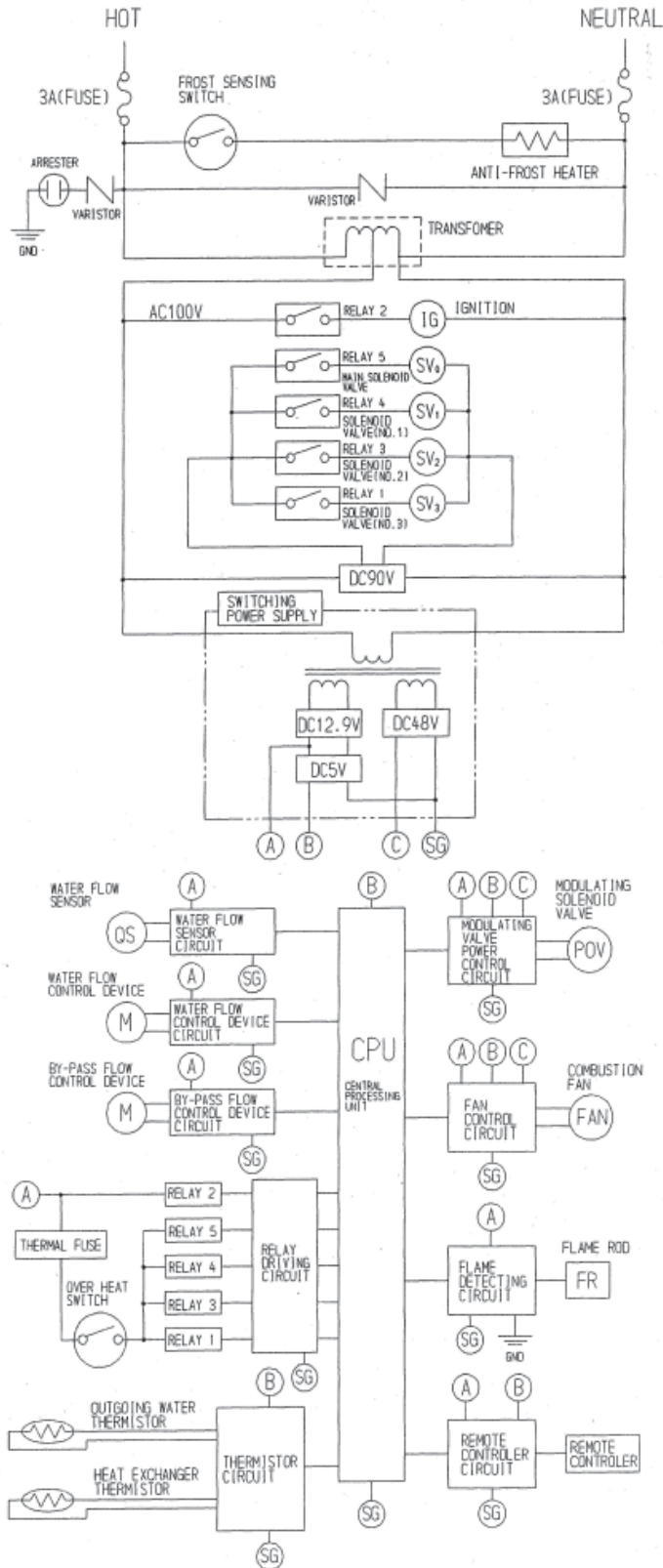

22. Electrical Component Analysis



Before carrying out checks marked with a # sign, disconnect power supply.
Unit's wiring diagram can be found on page 35.

Appliance fails to operate (even remote control fails to operate).	
1) Is the fuse blown	
<p>Fuses are located in plastic holders in the main harness, on the lower right hand side of the appliance.</p>	<p>Check fuse.</p> <ol style="list-style-type: none"> a. Disconnect unit from power supply. b. # Measure resistance to check the electric fuse (3 amp) <p><i>Normal:</i> less than 1Ω If normal, proceed to check item 2 below. <i>Faulty:</i> Replace 3 amp glass fuse. If the fuse blows again, investigate cause of short circuit.</p>
2) Is the main transformer normal ?	
	<p>Check the transformer.</p> <ol style="list-style-type: none"> a. Measure the voltage and/or resistance at connector F, black ~ white wires. <p><i>Normal:</i> 100 ~ 120 VAC 51 ~ 63 Ω resistance</p> <p><i>Faulty:</i> Check for 120 – 125 VAC at the surge protector, blue ~ brown wires, connector F₇.</p> <p style="padding-left: 40px;">Resistance reading 51 ~ 63 Ω</p> <p>If normal, check item 3 on next page. <i>Faulty:</i> Replace the transformer.</p>

3) Is the remote control normal ?

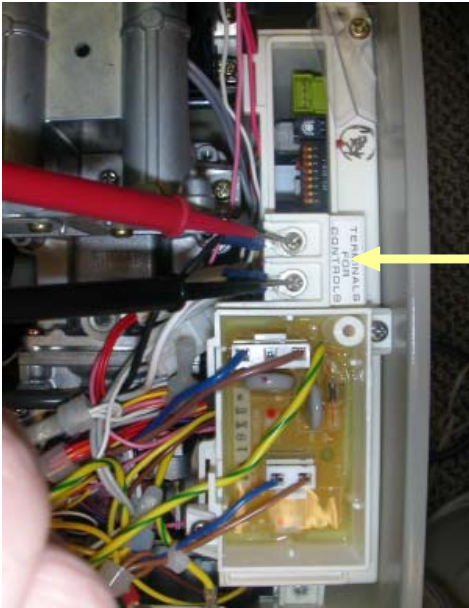

Check voltage between the two remote control cable connectors.

- a. Check the voltage between terminals on the remote control terminal mount D₁.
Normal: 11 ~ 13 VDC
If normal, check for an open circuit or short before replacing the remote control.
Faulty: Replace PCB.

No combustion (despite remote control indication)

1) Is the water flow sensor normal ?



Check the water flow sensor.

- a. Check the voltage at PCB connector B₄, red and black wires.
Normal: 11 ~ 13 VDC or 5.8 ~ 6.4K Ω
If normal, check (b) below.
Faulty: Replace the PCB.
- b. Check the voltage at PCB connector B₄, yellow and black wires.
Normal: 4 ~ 7 VDC or 1M ~ 1.2M Ω .
If normal, proceed to check item 2 on next page.
Faulty: Replace the water flow sensor.

2) Is the flame rod normal ? Error “72” is displayed

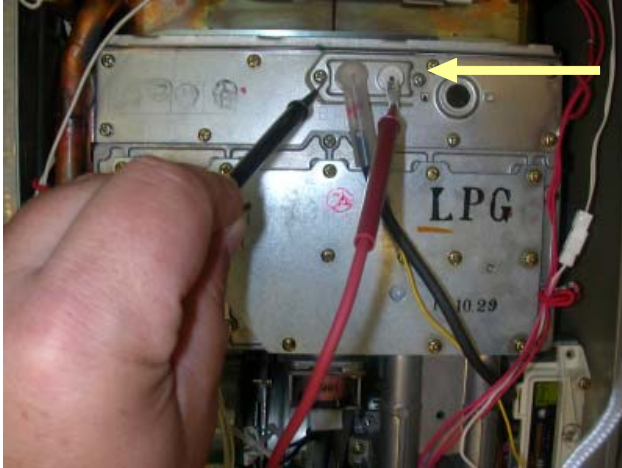

Checking the flame rod.

- a. # Detach the flame rod terminal C₁, and re-attempt operation.
("72 is displayed)
Proceed to check item 3 below.
(no "72" displayed)
Inspect flame rod wiring for current leak and inspect flame rod for carbon build-up.

Measure resistance between the flame rod Terminal C₁ and the appliance earth.

Normal: 1 MΩ or more.

If normal, replace the PCB unit.

Faulty: Replace the flame rod.

See page 43 for additional information and reading pertaining to the flame rod.

3) Is the water temperature thermistor normal ?

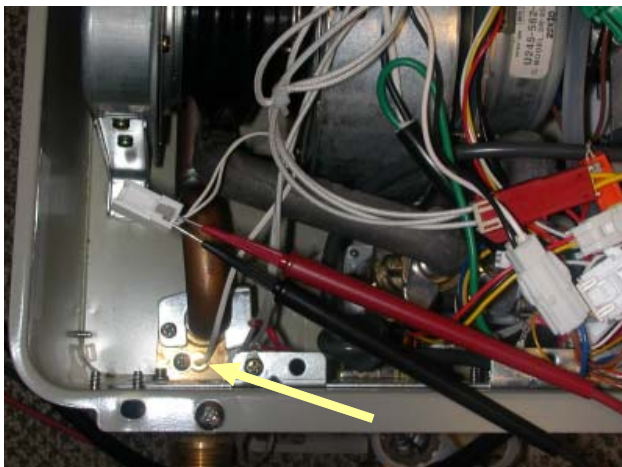

If error “32” is displayed, check the water temperature thermistor.

- a. # Disconnect connector B₅, and measure resistance of the white ~ white wires.

Resistance > 1 MΩ = open circuit.

Resistance < 1Ω = short circuit.

Normal: Proceed to check item 4 on the next page.

Faulty: Replace the water temperature thermistor.

See page 44 for additional information and reading pertaining to the temperature thermistor. .

4) Is the combustion fan motor normal ?

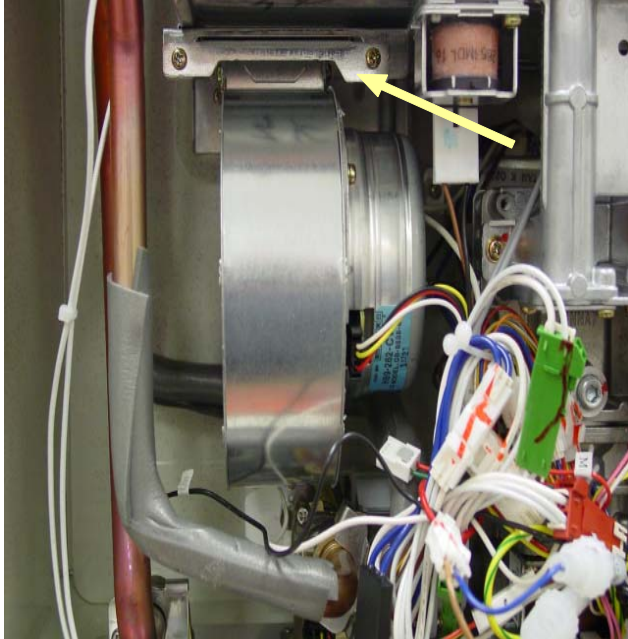

Motor check.
If error “61” is displayed, check the combustion fan.

- a. Measure voltage at connector A₁. Black and red wires.
Normal: 6 ~ 45 VDC (Fan on)
0 VDC (Fan off)
If normal, check item b below.
Faulty: Replace the PCB unit.

Fan revolution sensor check.

- b. Measure voltage at connector A₁, black and yellow wires.
Normal: 11 ~ 13 VDC or 3.1 ~ 3.7 K Ω
If normal, check item c below.
Faulty: Replace the PCB unit.
- c. Measure voltage at connector A₁, black and white wires.
Normal: 6 ~ 45 VDC or 9 ~ 9.4 K Ω
(33 ~ 400 Hz.)
If normal, proceed to check item 5 below.
Faulty: Replace the combustion fan motor.

5) Is the sparkler operating normally ?



Check the sparkler module.

- a. Measure voltage at connector F₈, grey and grey wires.
Normal: 90 ~ 110 VAC
0 VDC (when fan is off)
If normal, check b below.
Faulty: Replace the PCB unit.
- b. # Disconnect connector F₈, and measure the resistance between the two sparkler terminals.
Normal: > 1 M Ω
Faulty: Replace the igniter module.

Electrode gap should be $\frac{3}{16}$ ” to $\frac{1}{4}$ ” .

6) Is the main gas solenoid valve (SV0) operating normally ?

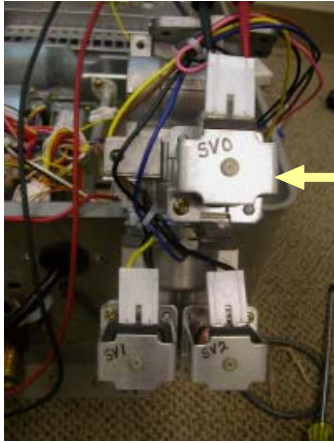

If error "11" or "71" is displayed, check the main gas solenoid valve.

- a. # Disconnect the main gas solenoid valve (SV0) connector and measure the resistance at the solenoid terminals.

Normal: 1.7 ~ 2.1 K Ω

If normal, check b below.

Faulty: Replace the main gas solenoid valve.

- b. Measure voltage at the main gas solenoid (SV0) Pink and black wires.

Normal: 80 ~ 100 VDC

If normal, proceed to check item 7 below.

Faulty: Replace PCB unit.

7) Is the change over solenoid (SV1) operating normally ?



If error "11" or "71" is displayed, check the change over solenoid (SV1).

- a. # Disconnect the change over solenoid (SV1) connector, and measure resistance at the solenoid terminals.

Normal: 1.7 ~ 2.1 K Ω

If normal, check b below.

Faulty: Replace the change over solenoid (SV1).

- b. Measure voltage at the change over solenoid (SV1) yellow ~ black wires.

Normal: 80 ~ 100 VDC

If normal, check 8 below.

Faulty: Replace PCB unit.

8) Is the change over solenoid (SV2) operating normally?

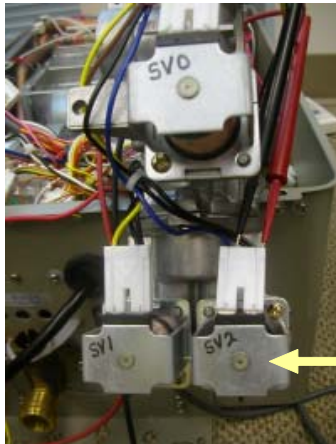

If error "11" or "71" is displayed, check the change over solenoid (SV2).

- a. # Disconnect the changeover solenoid (SV2) connector, and measure the resistance at the solenoid terminals.

Normal: 1.7 ~ 2.1 K Ω

If normal, check b below.

Faulty: Replace the changeover solenoid (SV2).

- b. Measure the voltage at the changeover solenoid (SV2), blue – black wires.

Normal: 80 – 100 VDC

If normal, check 9, on next page.

Faulty: Replace the PCB unit.

9) Is the change over solenoid (SV3) operating normally?

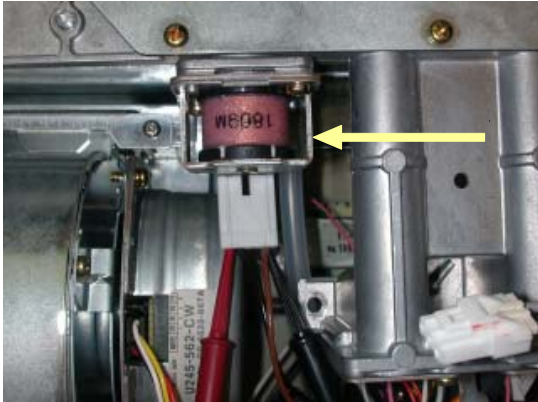

If error “11” or “71” is displayed, check the change over solenoid (SV3).

- a. # Disconnect the changeover solenoid (SV3) connector, and measure the resistance at the solenoid terminals.

Normal: 1.7 – 2.1 K Ω

If normal, check b below.

Faulty: Replace the changeover solenoid (SV3).

- b. Measure the voltage at the changeover solenoid (SV3), brown – black wires.

Normal: 80 – 100 VDC

If normal, reconfirm gas pressures are correct..

Faulty: Replace the PCB unit.

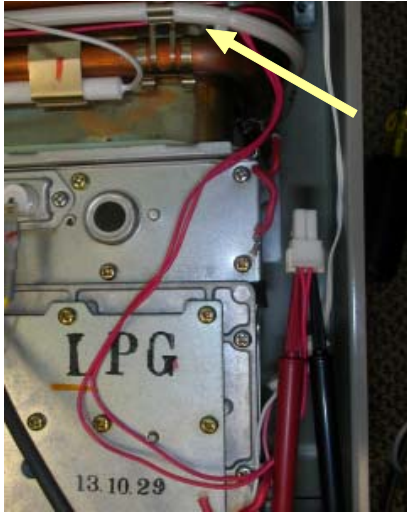

Error code “14” Check the thermal fuse.

- a. # Disconnect connector B₃ and C₃, measure the resistance between the red – red wires.
Normal: Less than 1Ω
 If normal, check b below.
Faulty: Check manifold gas pressure. Check heat exchanger for cracks and/or separations. If there is nothing abnormal, replace the thermal fuse.

- b. Check bi-metal switch, (remaining flame safety device). Measure resistance between the two terminals at B₃ and C₃.
Normal: 100 – 120 VAC
 If normal, process to item a below.
Faulty: Replace the bi-metal switch.

Combustion stops due to flame failure

1) Is the flame rod functioning normally ?

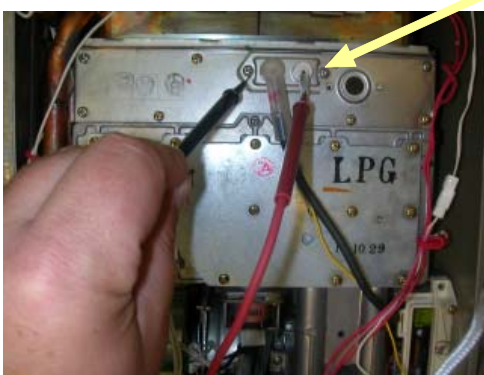

- a. Measure the voltage between the flame rod terminal C₁ and the appliance earth.
Normal: 5 – 150 VAC from yellow to ground.
 If normal, check b below.
Faulty: Replace the PCB unit.

- b. Check that the flame rod attachment is not loose.
Normal: Replace the PCB unit.
Faulty: Secure the flame rod bracket.

2) Is the earth lead wire connected ?

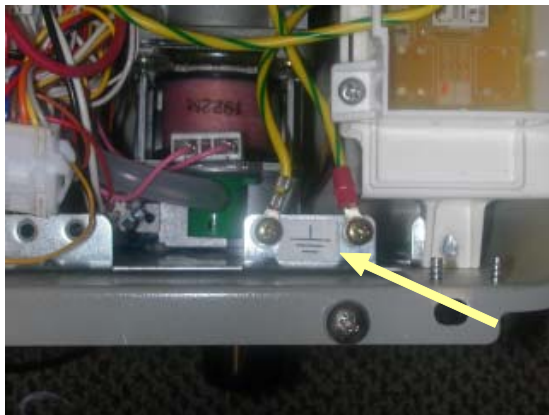

- a. Check for defective earth terminal, or an open circuit or short. If normal, investigate other possible causes for the flame failure.
 (Eg. Is the gas valve open ? Is the filter mesh blocked ?) Was proper venting material used? Did you regulate your gas supply pressure to the proper gas pressure for gas type being used?

Faulty: Ensure unit is properly grounded. Check ground circuit outside home at service pole. There should be an eight foot ground rod driven in the earth and a copper lead tied to the service meter. Ensure connection on ground rod is tight.

Unable to adjust hot water temperature

1) Is the water temperature thermistor operating normally ?

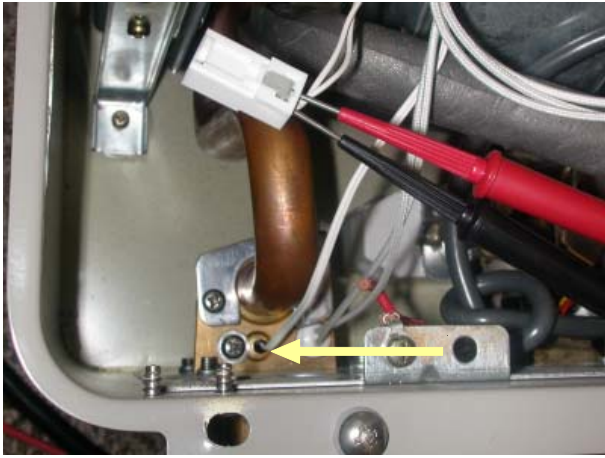

- a. # Disconnect the connector B₅, and measure the resistance between the white wires, see below for resistance readings.

Thermistor resistance valves:

59 °F = 11.4 ~ 14 KΩ

86 °F = 6.4 ~ 7.8 KΩ

113 °F = 3.6 ~ 4.5 KΩ

140 °F = 2.2 ~ 2.7 KΩ

221 °F = 0.6 ~ 0.8 Ω

Normal: Proceed to check item 2 below.

Faulty: Replace the water temperature thermistor.

2) Is the change over solenoid (SV1) normal ?

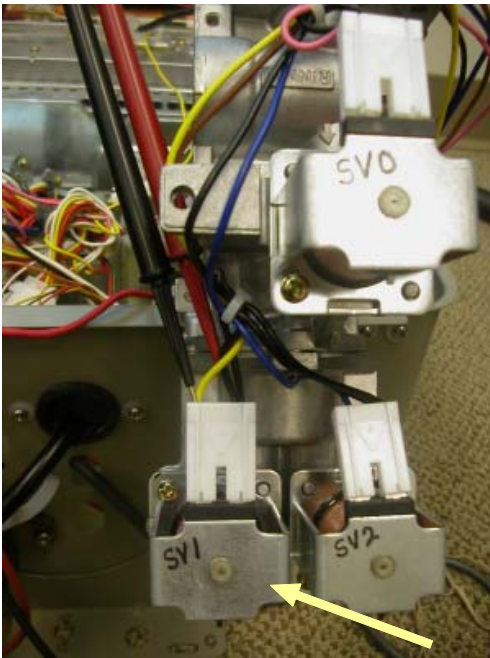

- a. # Disconnect the changeover solenoid (SV1) connector, and measure resistance at the solenoid terminals.

Normal: 1.7 ~ 2.1 KΩ

If normal, proceed to b.

Faulty: Replace the changeover solenoid (SV1).

- b. Measure the voltage at the changeover solenoid (SV1) yellow ~ black wires.

Normal: 80 ~ 100 VDC

If normal, proceed to check item 3, on next page.

Faulty: Replace the PCB unit.

3) Is the modulating valve operating normally ? Error code 52

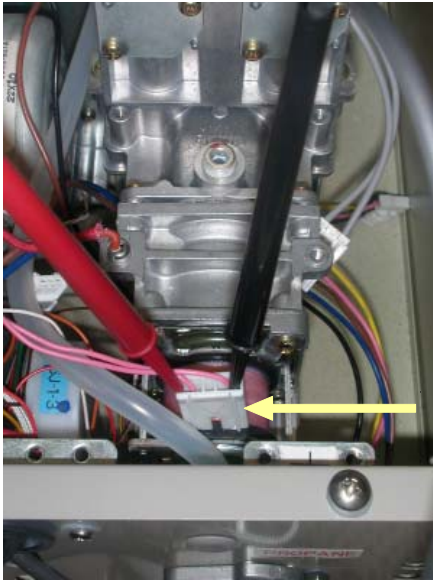

- a. # Disconnect the modulating valve festoon C₂ terminals and measure the resistance at the terminals.
Normal: 67 ~ 81 Ω
If normal, check b.
Faulty: Replace modulating valve.
- b. Re-connect terminal C₂ and measure voltage across the pink ~ pink wires when the unit is firing.
Normal: 2 ~ 15 VDC
If normal, check c below.
Faulty: Replace the PCB unit.
- c. Investigate the change in the manifold gas pressure, when the remote control pre-set temperature is altered from 96 ~ 140 °F.
Normal: If the manifold pressure changes, proceed to check item 4 below. **DO NOT** adjust manifold pressures.
Faulty: Replace modulating valve.

4) Is the water flow servo normal ?



- a. # Disconnect connector B₂ and measure the resistance of the water flow servo, red ~ blue wires.
Normal: 19 ~ 24Ω
If normal, proceed to b.
Faulty: Replace the water flow servo and sensor.
- b. Disconnect connector B₂ , and measure the voltage on the PCB unit side, were the orange (+), and/or grey or black (-) wires connect to the board.
Normal: 3.3 ~ 4.5 VDC
If normal, proceed to c.
Faulty: Replace the PCB unit.
- c. With connector B₂ , connected (do not turn water ON ... wait for the water flow servo to return to fully open), measure the voltage at the brown ~ grey wires.
Normal: 4 ~ 6 VDC vent limiter OFF
Faulty: Replace the water flow servo and sensor.
- d. With connector B₂ , connected (do not turn water ON... wait for the water flow servo to return to fully open), measure the voltage at the yellow ~ grey wires.
Normal: Less than 0.5 VDC when unit is set at 120 °F and there is no water flowing through the unit. .
Faulty: Replace water flow servo and sensor.

Anti-frost heaters do not operate

1) Are the ceramic anti-frost heaters OK ?

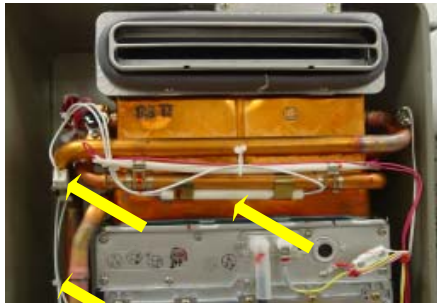
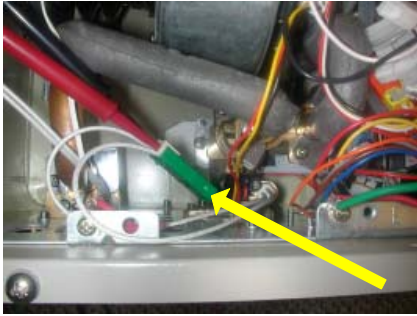

a. # Disconnect connector F₄, and measure the resistance of the heater mounted in the water flow control valve, these are white wires. Disconnect connector F₅, and measure the resistance of the heater in the outlet line connector See connectors in the first and second picture to the left.
Normal: 348 ~ 375 Ω
 If normal, proceed to b.
Faulty: Replace defective element.

b. # Take an ohm meter and read resistance across the heater on the face of the heat exchanger. The resistance across this element is listed below. See third picture to the left for location of this element. These are white wires.
Normal: 100 ~ 110Ω
 If normal, proceed to check item 2 below.
Faulty: Replace defective anti frost heater assembly.

c. Check resistance of the two heat exchanger outlet line heater elements, as shown in the third picture to the left. Check across each heater independently.
Normal: 33 ~ 39Ω
Faulty: Replace defective anti frost heater assembly.

2) Is the frost sensor switch operating normally ?

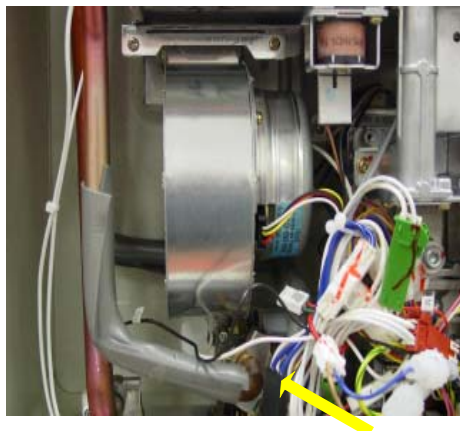

a. # Disconnect connector F₂, and measure the resistance through this switch, measure when atmospheric temperature is 39 °F + or - 3 °F. See drawing to left for location of this sensor, these are blue wires to this switch.
Normal: Less than 1Ω
 If normal, check wiring harness for defects. (100 volts AC)
Faulty: Replace the frost sensing sensor.
 # If the atmospheric temperature is too high, cool the switch with ice.

23. ELECTRICAL COMPONENT ANALYSIS



Nature of Fault	Examination Point	Diagnostic Point	Values	Y/N	Action	Repair N°		
A. The LED on the remote control does not light up, when the system is powered up	1. Do you have voltage to the unit?	Inspect visually	Do you have 120 VAC at the power supply?	Yes	Go to A – (2)			
				No	Plug in cord	1		
	2. Is supply voltage correct?	Measure voltage at power point.	120 VAC	Yes	Go to A – (3)			
				No	Check power supply circuit. Check fuses.	2		
	3. Check surge protector.	Inspect visually	Do you have 120 volts AC across the blue and brown wires at the surge protector?	Yes	Go to A – (4)			
				No	Go to A – (5)			
	4. Check 3 amp electrical fuses.	# Disconnect and measure resistance to confirm if fuse is blown. Normal < than 1MΩ	Is fuse blown.	Yes	Go to A – (5) and replace fuse.			
				No	Go to A – (6)			
	5. Check for short circuits.	1. Measure resistance of each solenoid valve. # Remove connector E from the PCB before measuring . Pink ~ Black (SV0) 1.7 ~ 2.1KΩ Yellow ~ Black (SV1) 1.7 ~ 2.1KΩ Brown ~ Black (SV2) 1.7 ~ 2.1KΩ	Are valves within those specified at left? # Measure after checking that there are no broken wires or shorts.	Yes	Go to A – (6) - 2			
				No	Replace faulty solenoid valves.	3		
				1. Measure the resistance. # Disconnect sparker connector F ₈ and measure the resistance between both terminals.	Is resistance > 1MΩ ?	Yes	Go to A (5-3)	4
					No	Replace sparker.		
				3. Check wiring.	Are there any shorts ?	Yes	Rectify/ Replace	5
						No	Replace PCB	6
6. Check to ensure you have 120 VAC across both terminals feeding the surge protector.	1. Measure voltage at the blue and brown or black and white wires.	100 ~ 120 VAC	Yes	Go to A (6-2)				
			No	Check for proper voltage to unit.				

Nature of Fault	Examination Point	Diagnostic Point	Values	Y/N	Action	Repair N°
		2. Measure the voltage at connector F with appliance power supply on. F – Black ~ white 100 ~ 120 VAC F ₇ – Blue ~ Brown 100 ~ 120 VAC	Are valves within those specified at left.	Yes	Go to A – (7)	
		No		Replace transformer	8	
	7. Check remote(s) (where connected).	Measure voltage between remote control terminals at D.	11 ~ 13 VDC Digital	Yes	Check cable for shorts or broken wires. Replace remote control	9
				No	Replace PCB.	10
B. Digital monitor lights up, but combustion does not commence. (When remotes are connected).	1. Check water flow sensor.	1. Measure voltage between red ~ black of connector B ₄ .	11 ~ 13 VDC	Yes	Go to B-1-2	
				No	Replace PCB	11
		2. Measure voltage between yellow ~ black at connector B ₄ .	4 ~ 7 VDC	Yes	Go to B - 2	
				No	Replace water flow sensor.	12
Error code “72” displayed on the digital monitor.	2. Check flame rod	# Measure resistance between flame rod terminal C ₁ and earth	Resistance > 1MΩ?	Yes	Replace PCB	13
				No	Replace flame rod	14
Error code “32” displayed on digital monitor.	3. Check outgoing water temperature thermistor.	# Disconnect connector B ₅ and measure resistance. Open circuit: > 1MΩ Short circuit: <1Ω	Are values as shown at left.	Yes	Replace water temperature thermistor.	15
				No	Go to B-4	
Error code “61” displayed on digital monitor	4. Check combustion fan.	1. Check motor. Measure voltage between black ~ red at connector A ₁ .	6 ~ 45 VDC (Fan on)	Yes	Go to B-5-2	
			0 VDC (Fan off)	No	Replace PCB	16
		2. Check fan rotation sensor. Measure voltage between black ~ yellow at connector A ₁ .	11 ~ 13 VDC	Yes	Go to B-4-3	
				No	Replace PCB	18
		3. Measure voltage between black ~ white of connector A ₁ .	6 ~ 45 VDC	Yes	Go to B-5	
				No	Replace fan	19

Nature of Fault	Examination Point	Diagnostic Point	Values	Y/N	Action	Repair N°
Error code "11" displayed on digital monitor.	5. Check sparker.	1. Measure voltage between grey ~ grey of connector F ₈ (sparker)	90 ~ 110 VAC	Yes	Go to B-5-2	
				No	Replace PCB	20
2. # Remove connector F ₈ and measure the resistance between sparker terminals.		Is the resistance >1MΩ	Yes	Go to B-5-3		
	No	Replace sparker.	21			
3. Check if unit is sparking.	Is the sparker sparking?	Yes	Go to B-6			
		No	Adjust/replace electrode.	22		
6. Check main gas solenoid valve (SV0) Error code 71	1. # Disconnect the main solenoid valve connector E from the PCB, and measure resistance between pink ~ black (SV0)	1.7 ~ 2.1KΩ	Yes	Go to B-6-2		
			No	Replace main solenoid valve (SV0)	23	
2. Measure voltage between pink ~ black of SV0 connector.	80 ~ 100 VDC	Yes	Go to B-7			
		No	Replace PCB	24		
7. Check solenoid valve (SV1)	1. # Disconnect connector E from the PCB. Measure resistance between yellow ~ black (SV1)	1.7 ~ 2.1KΩ	Yes	Go to B-7-2		
			No	Replace (SV1)	25	
2. Measure voltage between yellow ~ black of SV1 connector.	80 ~ 100 VDC	Yes	Go to B-8			
		No	Replace PCB	26		
8. Check changeover solenoid valve (SV2)	1. #Disconnect connector E from PCB. And measure resistance between blue ~ black (SV2)	1.7 ~ 2.1KΩ	Yes	Go to B-8-2		
			No	Replace (SV2)	27	
2. Measure the voltage between blue ~ black of SV2 connector.	80 ~ 100 VDC	Yes	Go to B9			
		No	Replace PCB	28		
Error code "14" displayed on digital monitor	9. Check thermal fuse	1. #Disconnect connector B ₃ and C ₃ measure resistance between red ~ red	Is resistance <1Ω?	Yes	Go to B-10	
				No	Replace thermal fuse	29
10. Check overheat (remaining flame) bi-metal switch.	2. #Disconnect OHS (remaining flame) bi-metal switch festoon terminal B ₃ and C ₃ , and measure resistance between terminal on switch.	Is resistance <1Ω?	Yes	Replace PCB	30	
			No	Replace remaining flame bi-metal switch	31	

Nature of Fault	Examination Point	Diagnostic	Values	Y/N	Action	Repair N ^o .	
C. Combustion occurs, but flame fails. Error code "12" Displayed on digital monitor.	1. Check flame rod	1. Measure the voltage between flame rod terminal C ₁ and appliance ground.	5 ~ 150 VAC	Yes	Go to C-1-2		
				No	Replace PCB	32	
		2. Check to ensure flame rod bracket is not loose.		Is it secure?	Yes	Go to C-2	
					No	Replace/rectify	33
	2. Check ground wire.	Check for faulty ground wire connections at unit, receptacle, and ground rod to home, and for broken or shorted wires.	Are connections OK?	Yes	Check for other causes of flame failure.	34	
				No	Replace or repair grounding circuit to unit.	35	
D. Cannot adjust water temperature.	1. Check hot water thermistor.	# Disconnect connector B ₅ and measure the resistance between white ~ white. See diagnostic points on page #34 for temperature at various resistance.	Resistance values match table on page #44.	Yes	Go to D – 2		
				No	Replace water temperature thermistor.	36	
	2. Check changeover solenoid valve (SV3)	1. # Disconnect solenoid connector E from PCB and measure the resistance between brown ~ black.	1.7 ~ 2.1K Ω	Yes	Go to D-2-2		
				No	Replace (SV3)	37	
		2. Measure voltage between brown ~ black wire of the changeover solenoid valve (SV3) at connector E.	80 ~ 100VDC	Yes	Go to D-3		
				No	Replace PCB	38	
	3. Check modulating valve.	1. #Disconnect modulating valve at C ₂ festoon terminal and measure resistance at solenoid terminals.	67 ~ 81 Ω	Yes	Go to D-3-2		
				No	Replace modulating valve	39	
		2. Measure the voltage between the two harness terminals at C ₂ .	2 ~ 15VDC	Yes	Go to D-3-3		
				No	Replace PCB	40	
		3. Check whether the manifold pressure alters when remote control temperature is altered between 96° ~ 140°F.	Does the manifold pressure change?	Yes	Go to D-4		
				No	Replace modulating valve (POV)	41	
4. Check water flow servo	1. #Measure resistance between red ~ blue wires of the water flow servo connector B ₂ .	22 ~ 26 Ω	Yes	Go to D-4-2			
			No	Replace water flow servo sensor.	42		

Nature of Fault	Examination Point	Diagnostic Point	Values	Y/N	Action	Repair N°
		2. Measure voltage between orange (+) and grey (-) of the water flow servo connector B ₂ .	11 ~ 13 VDC	Yes	Go to 4-3	
				No	Replace PCB	43
		3. Measure voltage between brown ~ grey of water flow servo connector B ₂ . (Do not turn water on).	4 ~ 6 VDC	Yes	Go to D-4-4	
				No	Replace water flow servo sensor.	44
		4. Measure voltage between yellow ~ grey of the water flow servo connector B ₂ . (Do not turn water on)	4 ~ 6 VDC	Yes	Normal	
				No	Replace water flow servo sensor.	45
E. Anti-frost heater does not work.	1. Check anti-frost heater.	1. #Disconnect connector F ₃ and F and measure resistance across each of the heating elements. (White wires)	348 ~ 375Ω	Yes	Go to E-1-2	
				No	Replace Anti-frost heater located in the water valve.	46
		2. #Read resistance of the heating element that is mounted on the front of the heat exchanger. (White wires)	100 ~ 110Ω	Yes	Go to E-2	
				No	Replace anti-frost heater that is defective.	
	3. Read resistance of heating elements on the heat exchanger outlet hot water line.	33 ~ 39Ω	Yes	Go to E-2		
			No	Replace anti-frost heater that is defective.	47	
	2. Check frost sensing switch.	#Disconnect connector F ₂ and measure across the frost sensing relay located on the bottom left of the casing. This is a black plastic piece with two blue white connected to it. Check this switch at temperatures below 37°F. You can place an ice cube against the switch to activate it.	Is resistance <1Ω after applying ice to this switch for five minutes?	Yes	Check wiring	
				No	Replace Anti-frost sensing switch.	48

Gas Pressure Setting Procedure

CONTINUUM and INTEGRITY *REU-2532- W*

*All settings/adjustments must be performed
by a qualified Service Technician.*

1. Turn unit off at power source and turn off the gas to the water heater.
2. Remove the front cover from the water heater.
3. Remove the gas pressure test port plug. Connect manometer to this port. See Figure #1 for location of the test port plug. Turn on the gas to the water heater.
4. Flow water through the water heater at the maximum flow rate obtainable, at least three gallons per minute.
5. To adjust the “**Low**” fire pressure, set combustion control dip switch #7 to the “**ON**” position, and switch #8 to the “**OFF**” position (see figure #2 for location of combustion control switches.) This will put the unit into forced low fire. Check the pressure reading on your manometer. If the pressure needs adjusting, remove the rubber plug from the bottom of the water heater casing (located beneath the regulator), to access the regulator adjustment screw. Adjust the regulator screw to achieve the correct gas pressure. (See figure #1 for location of the regulator adjustment screw.) Below are the proper pressures for “**Low**” fire, per gas type.

Propane	<u>0.88” w.c.</u> @ 10” w.c. supply	(Low fire rate of 15,000 BTU’s)
Natural	<u>0.56” w.c.</u> @ 6” w.c. supply	(Low fire rate of 15,000 BTU’s)

6. To adjust the “**High**” fire pressure, set combustion control dip switch #7 to the “**ON**” position, and switch #8 to the “**ON**” position (see figure #2 for location of the combustion control switches), this will put the unit into forced high fire. Check the pressure reading on your manometer. If the pressure needs adjusting, adjust it by turning the high pressure “**Pot**”. See figure #2 for location of “high pressure setting pot”. Below are the proper pressures for “**High**” fire.

Propane	<u>5.1” w.c.</u> @ 10” w.c. supply	(High fire rate of 180,000 BTU’s)
Natural	<u>3.4” w.c.</u> @ 6” w.c. supply	(High fire rate of 180,000 BTU’s)

7. Verify both low and high fire pressures by placing the water heater into “**Forced Low Fire**” and “**Forced High Fire**” as described in steps 5 and 6 above. This completes the gas pressure setting procedure.

Dip switches #7 and #8 (combustion control switches), MUST be returned to the “Off” position, after setting the pressures.

8. Turn off the gas to the water heater. Remove the manometer connection. Reinstall the pressure port plug. Turn on the gas to the water heater and check for gas leaks around test port with a leak solution.
9. Reinstall the front cover and place the unit back into operation.
10. Verify you are getting the proper water temperature, as set on the controller at your outlets. If controllers are not being used the output temperature should be 120°F.

Figure #1

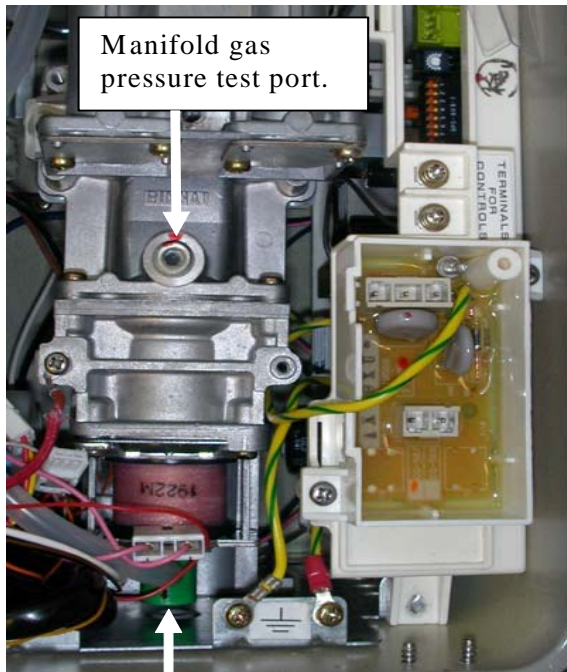

Regulator adjustment screw used when setting low and high fire manifold gas pressures only. DO NOT, adjust this screw without following gas pressure setting procedures.

Figure #2

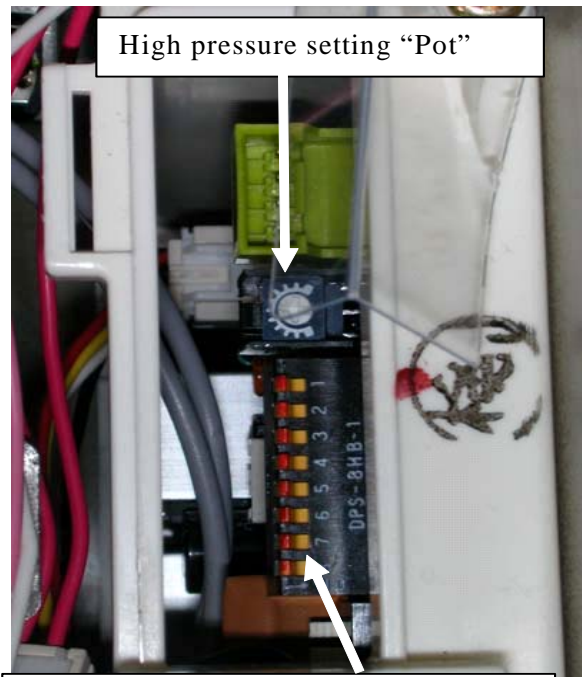

Dip switches #7 and #8 are used when adjusting low and high fire manifold gas pressures, as stated in the gas pressure setting procedure.

25. Dismantling for Service



NOTE: Before proceeding with dismantling, be sure to follow the **CAUTION** instructions before each explanation. Always disconnect the electrical supply, turn off water and gas supply service valves, and drain all water from the unit before proceeding. **Only trained and qualified service agencies should attempt to repair this product.**

<i>Item</i>	<i>Page</i>
1. Removal of the Front Panel	55
2. Removal of the PC Board	55
3. Removal of the Water Flow Control and Sensor	55
4. Removal of the Sparker	56
5. Removal of the Combustion Fan	56
6. Removal of the Water Temperature Thermistor	56
7. Removal of the Transformer	57
8. Removal of the Burner and Burner Manifold	57
9. Removal of the Gas Valve Assembly	58
10. Removal of the Heat Exchanger Assembly	58
11. Removal of the Thermal Fuse	59

Re-assembly in all task listed above in the reverse order of dismantling, unless stated otherwise.

IMPORTANT

When dismantling the unit you should always isolate the following items.

- Gas supply.
- Electrical supply.
- Water supply.
- Drain all water from the appliance.

The following diagram may be of assistance in locating the above.

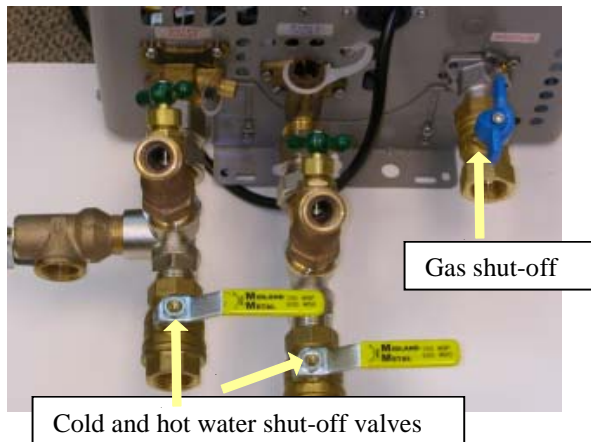

1. Removal of the Front Panel

CAUTION

120 volt potential exposure. Isolate the appliance and reconfirm power has been disconnected using a multi-meter.

- Remove the four (4) screws holding the panel in place with a Phillips driver.

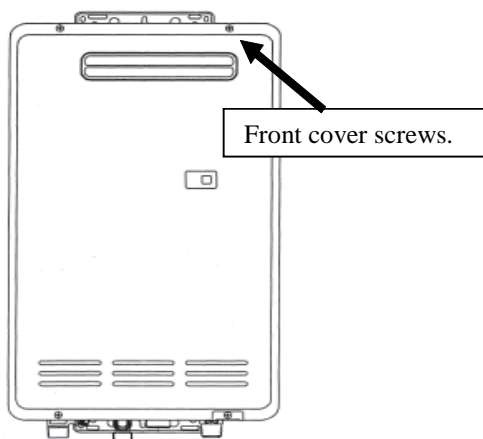

2. Removal of PC board

CAUTION

120 volt potential exposure. Isolate the appliance and reconfirm power has been disconnected using a multi-meter.

- Remove the two (2) screws holding the PCB in place with a Phillips screw driver, then pull the PC board out of the appliance. Disconnect all connectors.

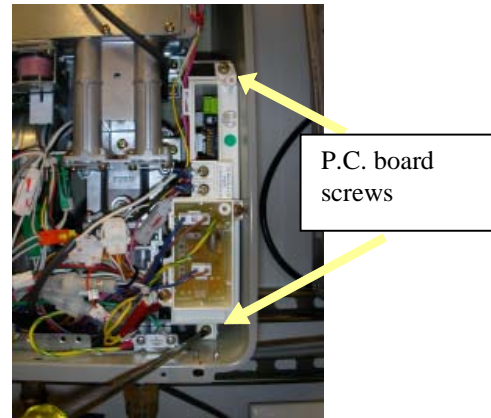

3. Removal of the Water Flow Sensor and Water Flow Control Valve Assembly

CAUTION

120 volt potential exposure. Isolate the appliance and reconfirm power has been disconnected using a multi-meter.

- Remove one (1) Phillips screw from the heat exchanger water supply line and (1) screw from the bypass valve assembly. Lift the water line retainer up and over the housing it attaches too, pull water line towards yourself to disconnect water lines from the assembly. Inspect o-rings for damage, replace if defective.

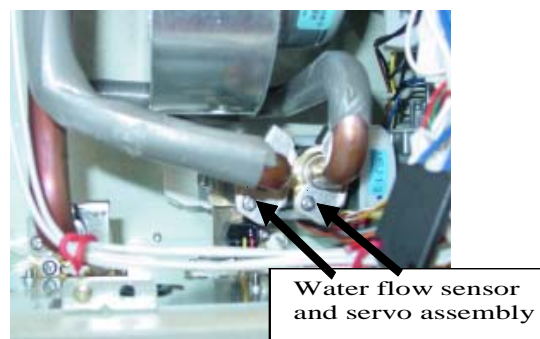

- a. Remove the four (4) Phillips screws that secure the water inlet filter housing to the unit. See picture below for location of screws. Once screws are removed reach into the unit and pull up and out on the flow control assembly to remove it from the appliance. Inspect o-ring for damage.



Water filter housing.

- b. Disconnect wiring harness from assembly and remove the water flow control assembly from the unit.

4. Removal of Sparker Module:

CAUTION

120 volt potential exposure. Isolate the appliance and reconfirm power has been disconnected using a multi-meter.

- a. Remove one (1) Phillips screw that secures the sparker module to the unit casing.
- b. Disconnect high tension lead and connector.

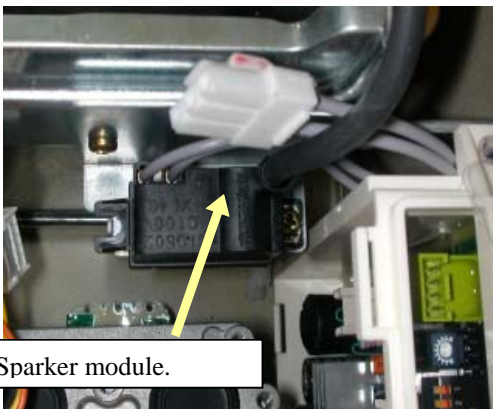

Sparker module.

5. Removal of the Combustion Fan:

CAUTION

120 volt potential exposure. Isolate the appliance and reconfirm power has been disconnected using a multi-meter.

- a. Disconnect wiring harness from fan motor.
- b. Remove the (2) Phillips screws that secure the combustion fan motor to the fan housing. Pull the fan motor assembly towards yourself to remove it.

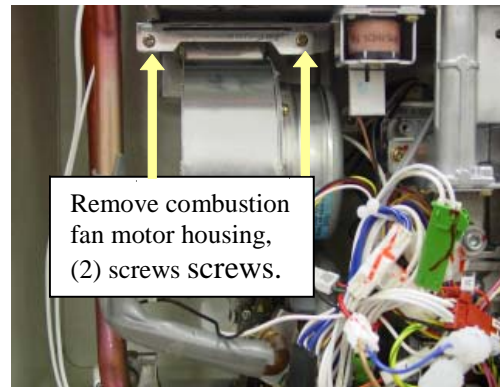

Remove combustion fan motor housing, (2) screws

6. Removal of the Water Temperature Thermistor:

CAUTION

120 volt potential exposure. Isolate the appliance and reconfirm power has been disconnected using a multi-meter.

- a. Remove the two (2) Phillips screws that secure the thermistor in place to remove the water outlet temperature thermistor.



Outlet water thermistor.

7. Removal of Transformer:

CAUTION

120 volt potential exposure. Isolate the appliance and reconfirm power has been disconnected using a multi-meter.

- Remove the combustion fan motor assembly as described in section 5-a,b.
- Remove the two (2) Phillips screws to release the transformer.
- Disconnect wiring harness connectors to transformer and pull out towards you.



8. Removal of Burner Manifold and the Burner:

CAUTION

120 volt potential exposure. Isolate the appliance and reconfirm power has been disconnected using a multi-meter.

- To remove the burner manifold, remove (6) Phillip screws around the burner plate as shown in the upper right picture.
- Remove the (3) Phillip screws at the gas valve assembly.
- Grip the burner manifold and remove it from the unit.

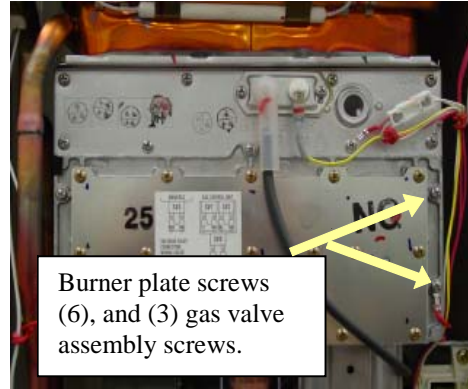

- To remove the burner assembly remove (8) Phillip screws around the sight glass panel. Remove this panel.
- Locate the (2) Phillip screws inside the burner chamber that hold the burner assembly in place. Remove these two screws, grip the burner assembly and slide it out of the combustion housing.

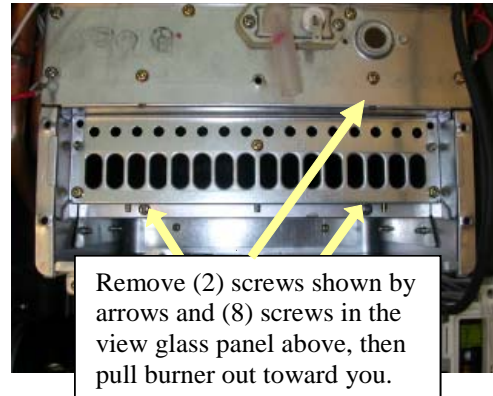

- If you need to remove each burner from this housing remove the (2) Phillip screws on each side of the burner, as shown below.

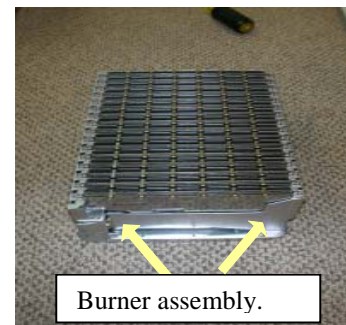

9. Removal of the Gas Valve Assembly:

CAUTION

120 volt potential exposure. Isolate the appliance and reconfirm power has been disconnected using a multi-meter.

- a. Remove the burner manifold, refer to section 8-a,b,c.
- b. Remove the four (4) Phillips screws that hold the gas connection and gas control valve in place at the bottom of the unit. Pull the gas connection down to disconnect it from the gas valve assembly. Inspect o-ring for damage and/or defects. Ensure o-ring is in place when re-assembling this connection.

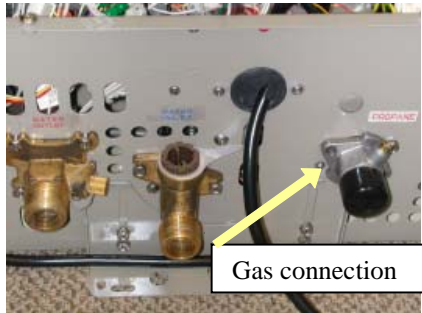

- c. Disconnect connectors from solenoids, note which connector goes to each solenoid, along with the proper wire colors. Pull gas valve assembly out of unit.

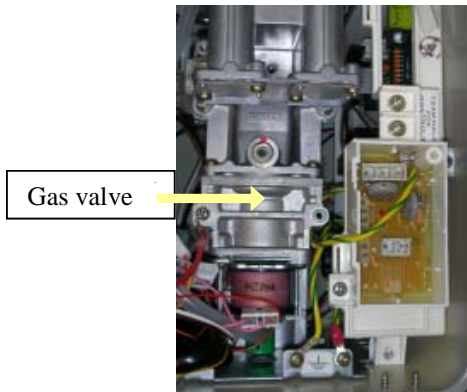

10. Removal of Heat Exchanger:

CAUTION

120 volt potential exposure. Isolate the appliance and reconfirm power has been disconnected using a multi-meter.

- a. Remove PCB unit, refer to section 2-a.

- b. Remove the heat exchanger water connection lines, refer to section 3-a.
- c. Remove the three (3) Phillip screws securing the gas manifold assembly to the gas control valve.
- d. Remove the six (6) Phillip screws that secure the heat exchanger assembly in place.
- e. Disconnect connectors B₁, B₅, B₆, C₁, C₃, F₁ and F₈. These are the igniter, flame rod, thermo-fuse, hot water inlet and outlet thermistor, and the anti-freeze heater connections.

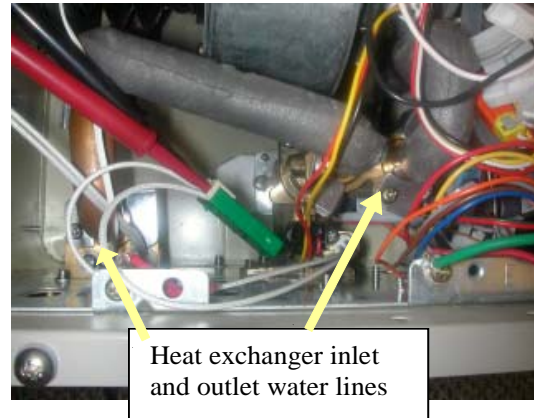

- f. Pull the heat exchanger out of the heater.
- g. Transfer all components found on the old heat exchanger over to the new exchanger.

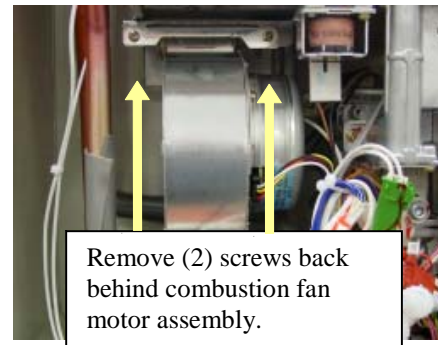
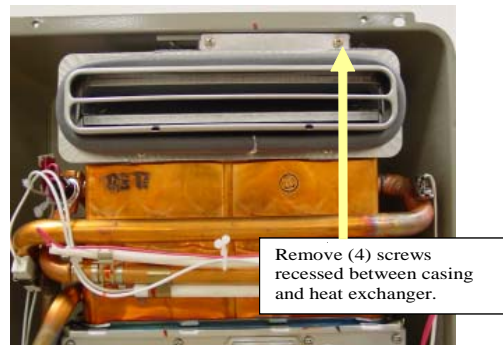

7. **Removal of Thermal Fuse:**

CAUTION

120 volt potential exposure. Isolate the appliance and reconfirm power has been disconnected using a multi-meter.

This process may involve removing the heat exchanger if the thermo-fuse on the rear of the heat exchanger is blown.

- a. The REU 2532 has four thermal fuses, see picture below for location.
- b. Disconnect and remove the thermal fuse. Re-install new thermo fuse using the existing thermo fuse clips. Reconfirm inlet and manifold gas pressures are set to the proper setting. Ensure unit matches gas type being supplied to the heater.

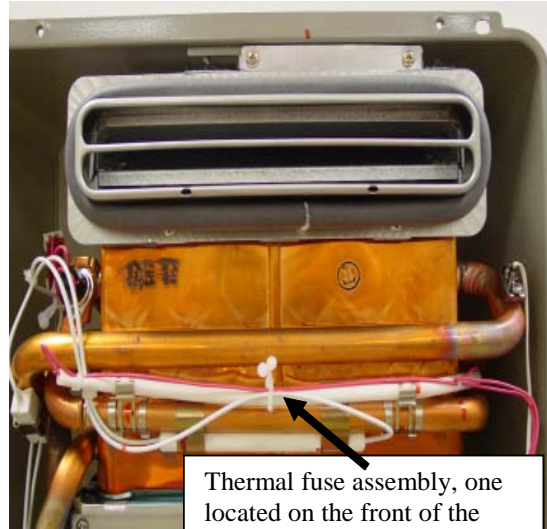

Thermal fuse assembly, one located on the front of the heat exchanger and one on the rear of this assembly.

26. EXPLODED VIEW - CABINET

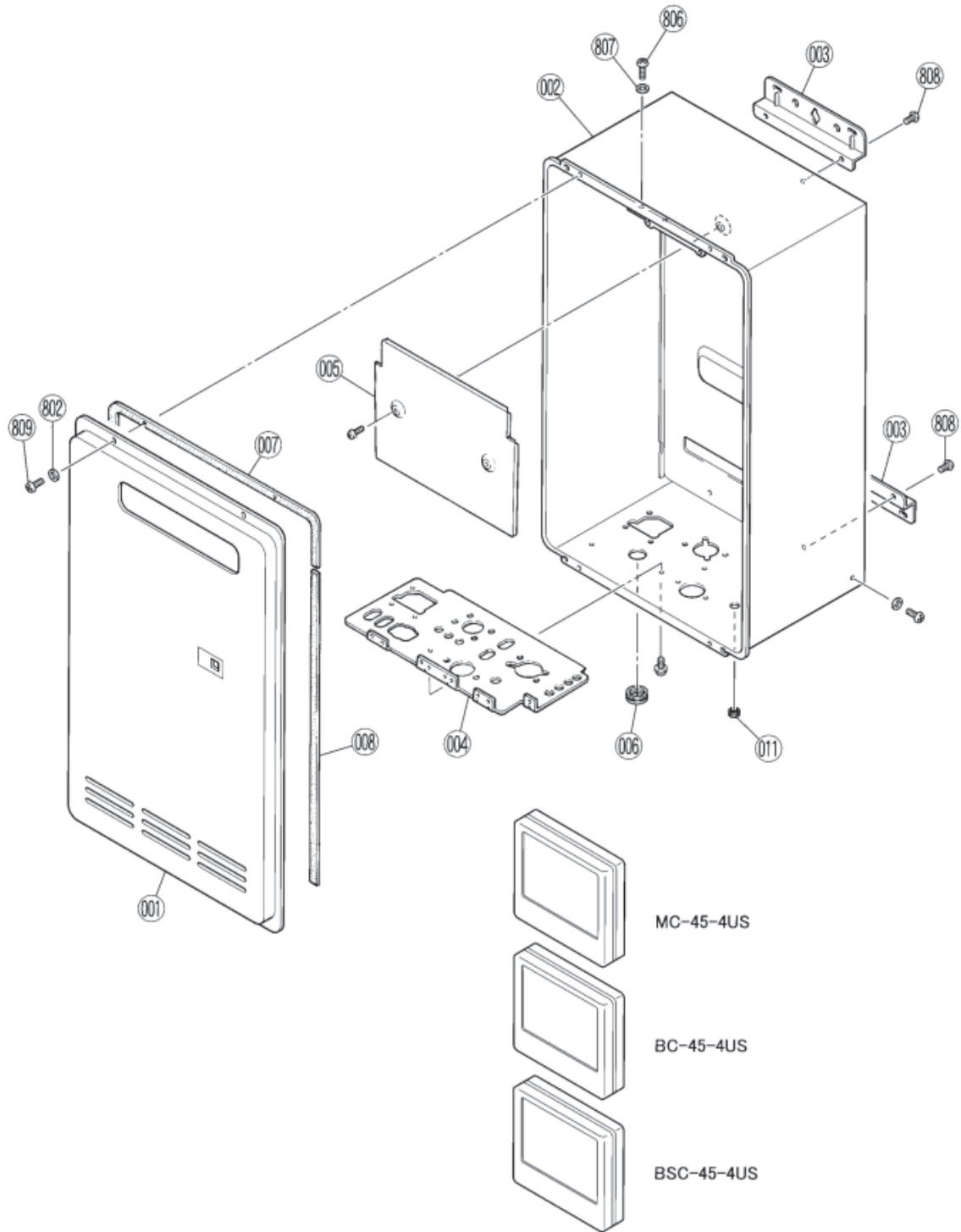

EXPLODED VIEW - INTERNALS

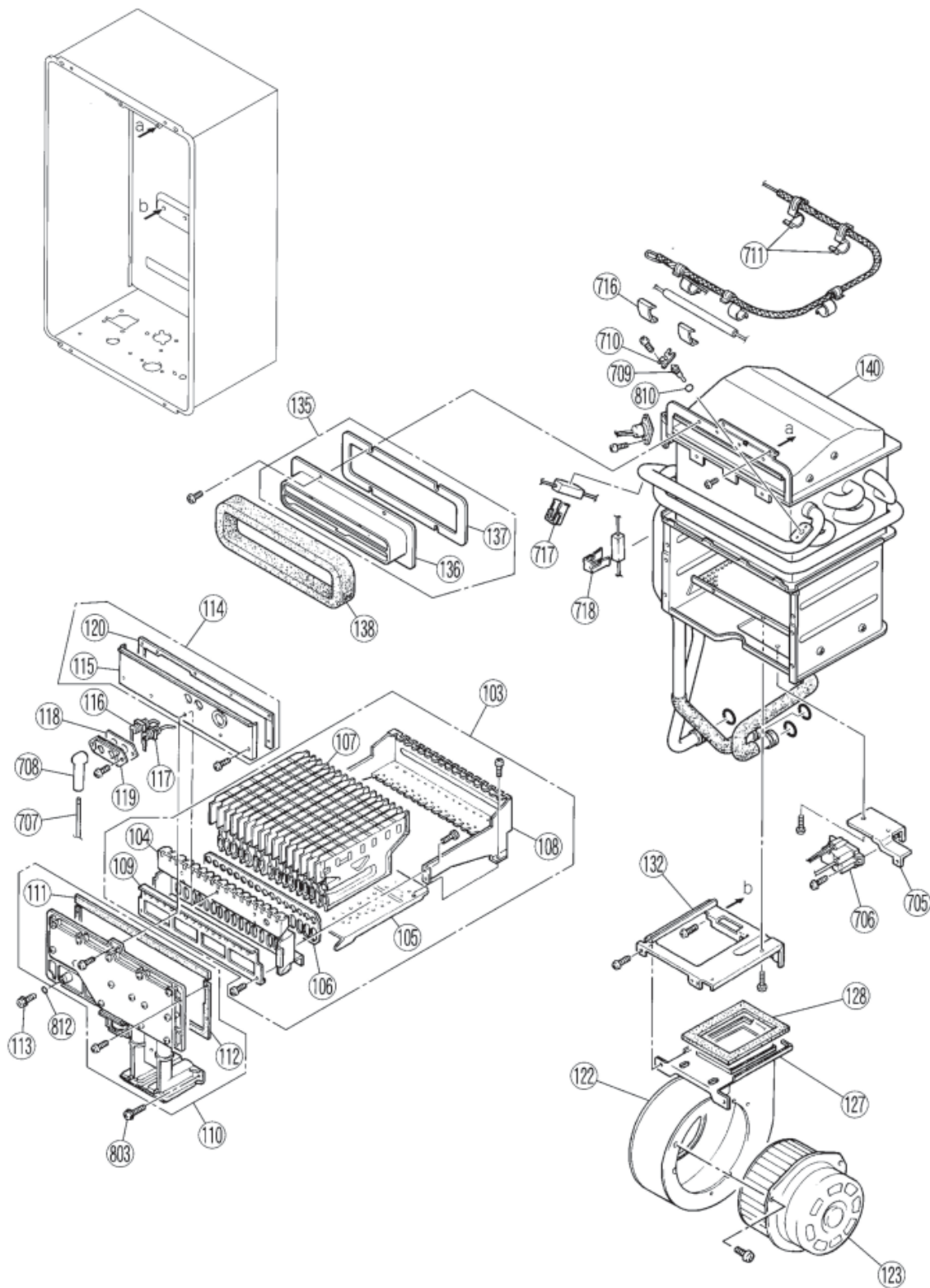

EXPLODED VIEW - INTERNALS

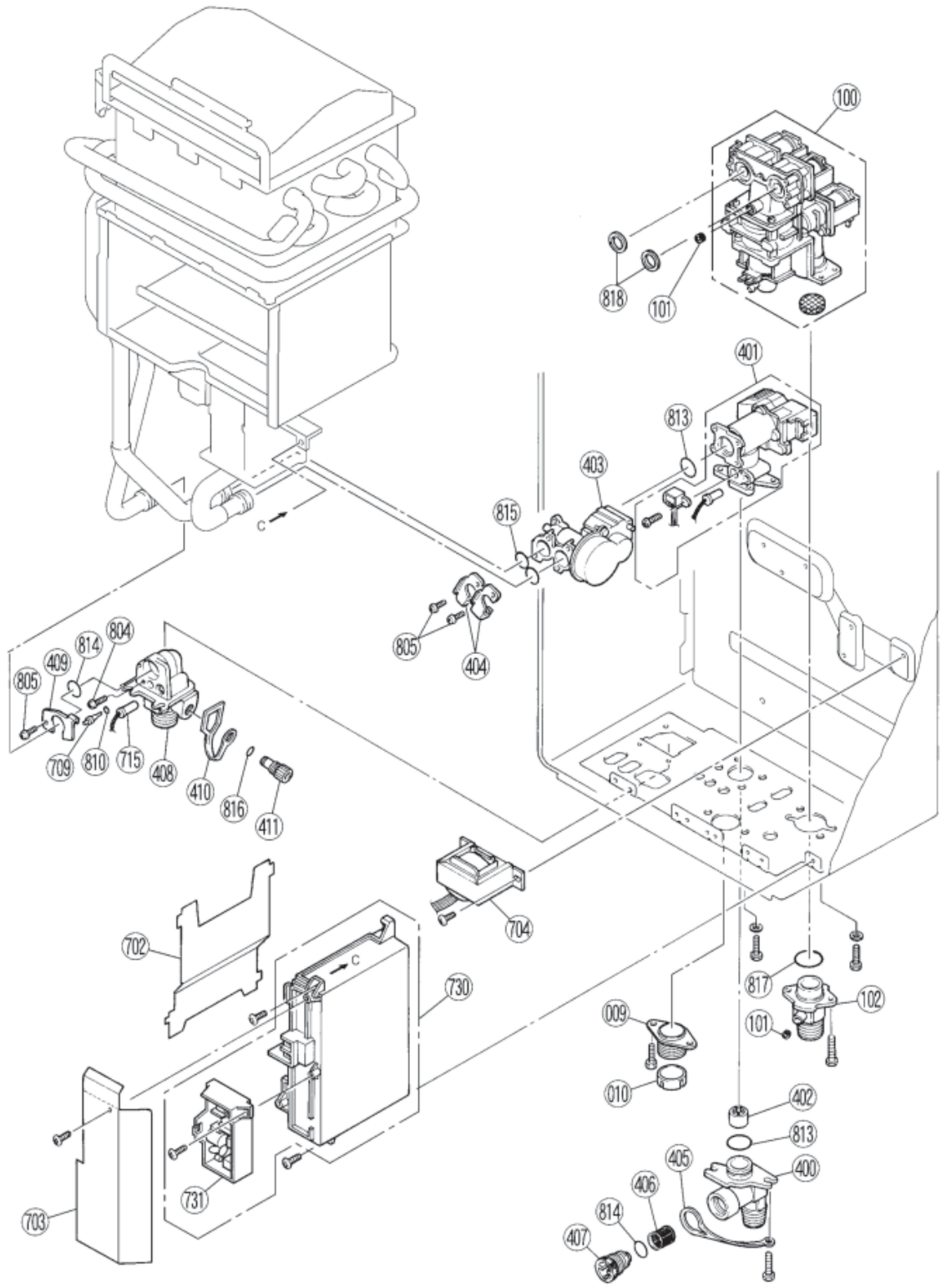

EXPLODED VIEW - ELECTRICAL

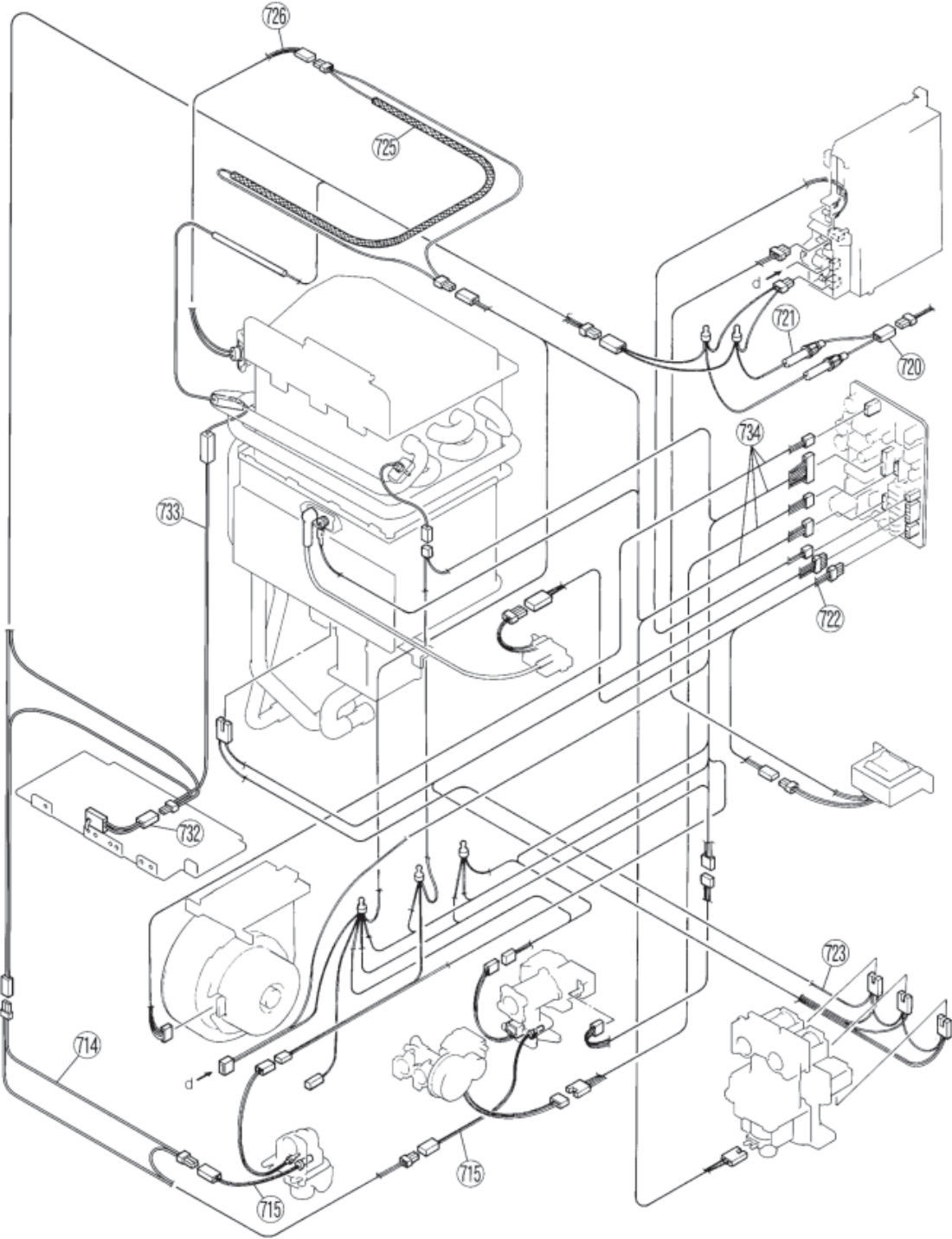

PARTS LIST

<u>Number</u>	<u>Description</u>	<u>Part Number</u>	<u>Quantity</u>
001	Front Panel Assembly	U245-1110	1
002	Casing Assembly	U245-1100	1
003	Wall Installation Bracker	U195-121	1
004	Connection Reinforcement Panel	U245-120	1
005	Heat Protection Plate	U245-107	1
006	Rubber Bushing	CF79-41020-A	1
007	Front Panel Packing	BU195-167	1
008	Front Panel Packing Side	AU115-163	1
009	Cable Connection	BU56-602-N	1
010	Cable Seal Packing	AU169-126	1
011	Seal Packing	AU105-113	1
100	Gas Control Assembly	C36E-41-S	1
101	Screw	AU39-965	2
102	“Gas Connection (3/4”NPT)”	CU195-1866	1
103	Burner Unit Assembly	H73-110	1
104	Burner Case Front	CH51-209	1
105	Burner Case Bottom Panel	H73-112	1
106	Packing	BH51-218	1
107	Lean and Rich Bunsen Burner Assembly	B3A7-1	16
108	Burner Case Back Panel	CH51-211	1
109	Damper	H73-115	1
110	Manifold Assembly-A (LPG)	U245-200-A	1
110	Manifold Assembly-C (Nat. G)	U245-200-C	1

PARTS LIST

<u>Number</u>	<u>Description</u>	<u>Part Number</u>	<u>Quantity</u>
111	Packing of Combustion Chamber	AU155-207-2	1
112	Lower Packing of Combustion Chamber	H73-214	1
113	Screw	C10D-5	1
114	Combustion Chamber Front Plate Assembly	U245-260	1
115	Combustion Chamber Front Plate	U245-261	1
116	Electrode	H73-120	1
117	Flame Rod	AH41-216	1
118	Electrode Packing	AH66-398	1
119	Electrode Holder	AH66-393	1
120	Upper Packing of Combustion Chamber	U245-262	1
122	Fan Casing Assembly	CH51-615	1
123	Blower Motor	H89-261	1
127	Fan Connecting Bracket	BH29-606	1
128	Fan Connecting Packing	AU183-562	1
132	Combustion Chamber Bracket	U245-255	1
135	Flue Outlet Assembly	U245-1131	1
136	Flue Outlet	U245-1130	1
137	Flue Outlet Packing	U245-1122	1
138	Flue Outlet Packing - 6	AH24-653-6	1
140	Heat Exchanger Complete Assembly	U245-1310	1
400	"Water Inlet (3/4"NPT)	H73-501-2	1
401	Water Flow Servo & Sensor Assembly	M8E-6-5	1
402	Rectifier	M8D1-15	1

PARTS LIST

<u>Number</u>	<u>Description</u>	<u>Part Number</u>	<u>Quantity</u>
403	By-pass Servo Assembly	M6J-1-3	1
404	Stop Bracket	AH69-310	2
405	Plug Band	H73-512	1
406	Water Filter Assembly	H73-511	1
407	Filter Plug	H73-510	1
408	Hot Water Outlet (3/4"NPT)	U245-865-3	1
409	Stop Bracket	AU162-1876	1
410	Plug Band Small	AU103-413	1
411	Drain Valve	AU142-444	1
702	PCB Cover-Side	BU195-507	1
703	PCB Cover-Front	BU168-707	1
704	Transformer Assembly	ET-281	1
705	PCB Bracket	U245-257	1
706	Ignitor	EI-189	1
707	High Tension Cord	BH38-710-240	1
708	Electrode Sleeve	AU206-218	1
709	Thermistor	BH45-650	2
710	Thermistor Clip Large	CP-90172	1
711	Thermal Fuse Clip	U217-676	5
714	Heater Connecting Harness	U245-621	1
715	120V Valve Heater Assembly	U245-622	1
716	Anti-Frost Heater Clip	CF29-752	2
717	Anti-Frost Heater Clip A	AU111-653	1

PARTS LIST

<u>Number</u>	<u>Description</u>	<u>Part Number</u>	<u>Quantity</u>
718	Anti-Frost Heater Clip	AU100-721	1
720	Power Supply Harness	AU195-1876	1
721	Fuse Harness	BU195-1630	1
722	100V Harness	U245-601	1
723	Solenoid Valve Harness	U245-602	1
725	Thermal Fuse Harness	U245-610	1
726	Mold-Type Over Heat Switch	BU129-824-2	1
730	PCB	U245-1200	1
731	Surge Protector	BU195-1873	1
732	Frost Sensing Switch	H73-750	1
733	120V Anti-Frost Heater Assembly	U245-1320	1
734	Sensor Harness - 2	U245-603-2	1
802	Washer	AU33-184	4
803	Screw	CP-21478-412	3
804	Screw	U217-449	1
805	Screw	ZAA0408UK	3
806	Screw	ZBD0508UK	2
807	Screw	AU48-174	2
808	Screw	ZBA0510UK	4
809	Screw	ZAD0408TK	4
810	O-ring	M10B-2-4	2
812	O-ring	M10B-13-4	1
813	O-ring	M10B-2-18	2

PARTS LIST

<u>Number</u>	<u>Description</u>	<u>Part Number</u>	<u>Quantity</u>
814	O-ring	M10B-2-16	2
815	O-ring	M10B-2-14	2
816	O-ring	M10B-2-7	1
817	O-ring	M10B-1-24	1
818	Packing	C36E1-6	2
888	V2532W Owner's Manual	U245-1360	1
-	Package Spec Sheet	PWB-261	1
-	"Manual 3/4" gas control valve"	BU195-1865	1
-	Kitchen remote control kit	MC-45-4US	1
-	Bathroom remote control kit	BC-45-4US	1
-	2nd Bathroom remote control kit	BSC-45-4US	1

SERVICEMAN'S TROUBLESHOOTING INFORMATION
for the
RINNAI “CONTINUUM REU2532-W” WATER HEATERS

IMPORTANT SAFETY NOTES:

There are a number of (live) tests that are required when fault finding this product. Extreme care should be used at all times to avoid contact with energized components inside the water heater.

Only trained and qualified service agencies should attempt to repair this product.

Remember, before checking for resistance readings, you should disconnect the power source to the unit and isolate item the to be checked from the circuit (unplug it).

(TR) Transformer:

Wire color	Voltage	Resistance	Connector #	Pin #'s
Black ~ White	100 ~ 120 VAC	51 ~ 63 ohms	F9	1 ~ 2
Blue ~ Brown	110 ~ 120 VAC	51 ~ 63 ohms	F7	1 ~ 3

(SV0, SV1, SV2, SV3 and POV) Gas valve and Modulating solenoids: (Set meter above 2K)

(SV0) Pink ~ Black	80 ~ 100 VDC	1,8K ~ 2K ohms	E1	1 ~ 2
(SV1) Black ~ Yellow	80 ~ 100 VDC	1,8K ~ 2K ohms	E2	2 ~ 3
(SV2) Black ~ Blue	80 ~ 100 VDC	1,8K ~ 2K ohms	E3	2 ~ 4
(SV3) Black ~ Brown	80 ~ 100 VDC	1,8K ~ 2K ohms	E4	2 ~ 5
(POV) Pink ~ Pink	2 ~ 15 VDC	67 ~ 81 ohms	C2	3 ~ 4

(M) Water Flow Control Device Servo or Geared Motor:

Red ~ Blue	11 ~ 13 VDC	22 ~ 26 ohms	B2	9 ~ 10
Grey ~ Brown	4 ~ 6 VDC	N/A	B2	5 ~ 7
Grey ~ Yellow	N/A	N/A	B2	5 ~ 8
Grey ~ Orange	11 ~ 14 VDC	N/A	B2	5 ~ 6

NOTE: The grey wire listed above turns to black at B connector on the PCB, the orange wire turns to red.

(QS) Water Flow Sensor:

Black ~ Red	11 ~ 13 VDC	5.5K ~ 6.2K	B4	5 ~ 6
Yellow ~ Black	4 ~ 7 VDC	1 meg ~ 1.4 meg	B4	1 ~ 5

By-pass Flow Control:

Brown ~ White	2 ~ 6 VDC	Unit in operating mode	G4 ~ G5	4 ~ 5
Orange ~ White			G2 ~ G5	2 ~ 5
Yellow ~ White		15 ~ 35K	G1 ~ G5	1 ~ 5
Red ~ White/ Ground			G3 ~ G5	3 ~ 5

(IG) Ignition System:

Grey ~ Grey	90 ~ 100 VAC	N/A	F8	2 ~ 3
-------------	--------------	-----	----	-------

(FM) Combustion Fan Motor:

Red ~ Black	6 ~ 45 VDC	N/A	A1	1 ~ 2
-------------	------------	-----	----	-------

White ~ Black	6 ~ 45 VDC	9.2K ~ 9.4K	A1	2 ~ 4
Yellow ~ Black	11 ~ 13 VDC	3.5K ~ 3.9K	A1	2 ~ 3

Set your meter to the hertz scale. Reading across the red and yellow wires at terminals 2 and 3 you should read between 60 and 350 hertz.

Thermal Fuse:

Red ~ Red	100 VAC	Below 1 ohm	B ~ C	B6 ~ C1
-----------	---------	-------------	-------	---------

Overheat Switch:

Red ~ Red	100 VAC	Below 1 ohm	B ~ C	B6 ~ C1
-----------	---------	-------------	-------	---------

Flame Rod:

Place one lead of your meter to the flame rod and the other to earth or ground. With the unit running you should read between 5 ~ 150 VAC. Set your meter to the μ amp scale, series your meter in line with the flame rod. You should read 1 μ or greater for proper flame circuit. In the event of low flame circuit remove the flame rod and check for carbon and/or damage.

Heat Exchanger, Air Temperature, and Outgoing Water Temperature Thermistors:

Check all thermistors by inserting meter leads into each end of the thermistor plug. Set your meter to the 20K scale and read resistance. You should be able to apply heat to the thermistor bulb and see the resistance decrease. Then apply some ice to the thermistor and the resistance should increase. See below for examples of temperatures and resistance reading at those temperatures.

- Example: 59°F = 11.4 ~ 14K
- 86°F = 6.4 ~ 7.8K
- 113°F = 3.6 ~ 4.5K
- 140°F = 2.2 ~ 2.7K
- 221°F = 0.6 ~ 0.8K

Outgoing Water Thermistor:

White ~ White	N/A	See example above	B	B3 ~ B4
---------------	-----	-------------------	---	---------

Heat Exchanger Temperature Thermistor:

White ~ Pink at board	N/A	See example above	B	B3 ~ B12
-----------------------	-----	-------------------	---	----------

Surge Protector:

Black ~ White	108 ~ 132 VAC	N/A	Surge Protector D ₁	1 ~ 3
Blue ~ Brown	108 ~ 132 VAC	N/A	Surge Protector D ₂	1 ~ 2

With the power off you can check the continuity through the surge protector. Place one meter lead on the top pin #1 of the surge protector and pin #2 on the bottom of the surge protector. Then check across top pin #3 and bottom pin #1, if you read continuity across these two points the surge protector is good. If you do not get continuity, replace the surge protector.

Remote Controls:

Terminals D ₁	10 ~ 13 VDC digital	1.5K ~ 1.9K ohms	H	1 ~ 3
--------------------------	---------------------	------------------	---	-------

Frost Protection:

This unit has four frost protection heaters mounted at different points inside the unit, to protect the water heater from freeze ups. There are two heaters located on the outlet hot water line next to the thermistor.

Using a voltage meter set on the 200 ohm scale, you should have a resistance reading of 26 ~ 30 ohms through each of these heaters. The heater located on the heat exchanger piping should have a resistance reading of 81 ~ 86 ohms and the one located in the water flow sensor valve has a resistance reading of 16 ~ 19 ohms. Voltage throughout this circuit should be 120 VAC.

(3) Amp Fuses:

This unit has two inline (3) amp glass fuses. Remove the fuse and check continuity through it. If you have Continuity through the fuse, it is good. If you can not read continuity, the fuse is blown and must be replaced.

Wiring Diagram:

REU2532-W

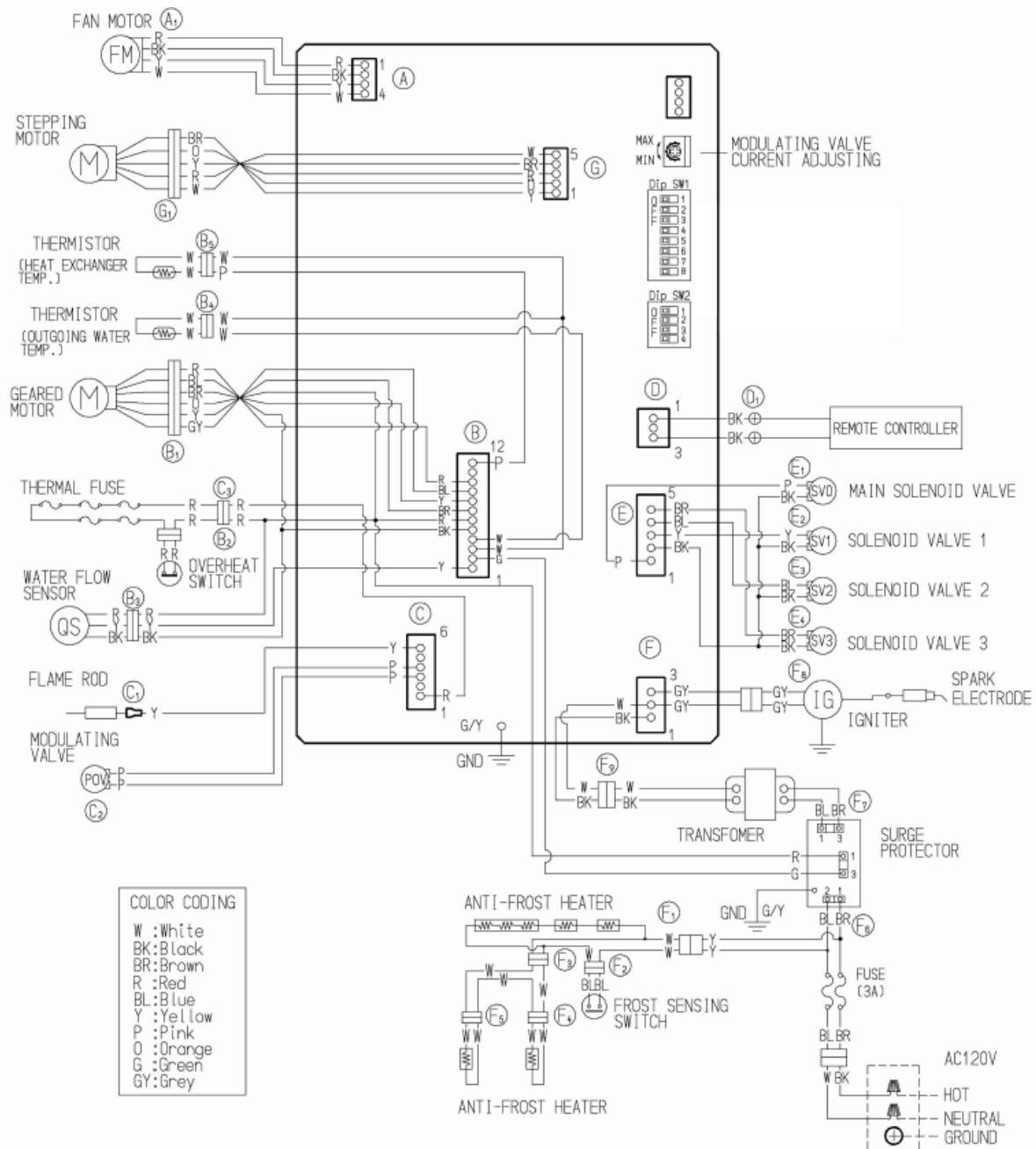

Ask about Rinnai's other fine products:

The Silent Servant



*North America's only vent-free convection heater

*99% efficient

*whisper quiet

*perfect for hard to heat areas

The Energy Savers

*Direct Vent Heating with style and performance

*whisper quiet

*available with multi-step set back thermostats



The Infra-reds

*Vent free radiant heaters

*99.9% efficient

*Heat like the sun

Portable Cooking Products

*One, two and two burner with broiler models.

*Perfect for camping, a picnic or a tailgate party



Rinnai

www.rinnai.us