

3420

3803

3420

3803

3420

3803

3420

3803

3420

3803

IBM 3420/3803

Magnetic Tape Subsystem

Reference Guide

IBM

3420/3803 REFERENCE GUIDE

PREFACE:

This reference guide was created by FE Service Planning to assist in maintaining the 3420/3803 magnetic tape subsystem. It is divided into sections for each major topic. Reference is made to the 3420/3803 MLM, and other publications that are required for effective 3420/3803 maintenance.

This guide is not eligible for suggestion awards unless a tangible savings can be shown.

Address any comments concerning this publication to:

International Business Machines Corporation
Field Engineering Service Planning
Department 96F, Building 005
Tucson, Arizona 85744



3420/3803 REFERENCE GUIDE

	SECTION
3420/3803 Tape Subsystem Maintenance Directory.....	1
3420/3803 General.....	2
MLM Content.....	3
EREP & Predictive Maintenance.....	4
3420 Read/Write Service Techniques.....	5
3420 Tape Motion Service Techniques.....	6
3420 Performance Enhancement Guide.....	7
3420 Quick Fix MAPS.....	8
Sense Byte Analysis.....	9
Media And Related Problems.....	10
3420/3803 Online Tests.....	11
3420/3803 Power Hints.....	12
Common System Abends.....	13
3420 Parts.....	14
Tools & Test.....	15
3803 Data Flow.....	16
3803 Micro Processor Tips.....	17
3803 Channel Interface.....	18
3420 ECA Listing.....	19
3803 ECA Listing.....	20
Index.....	21

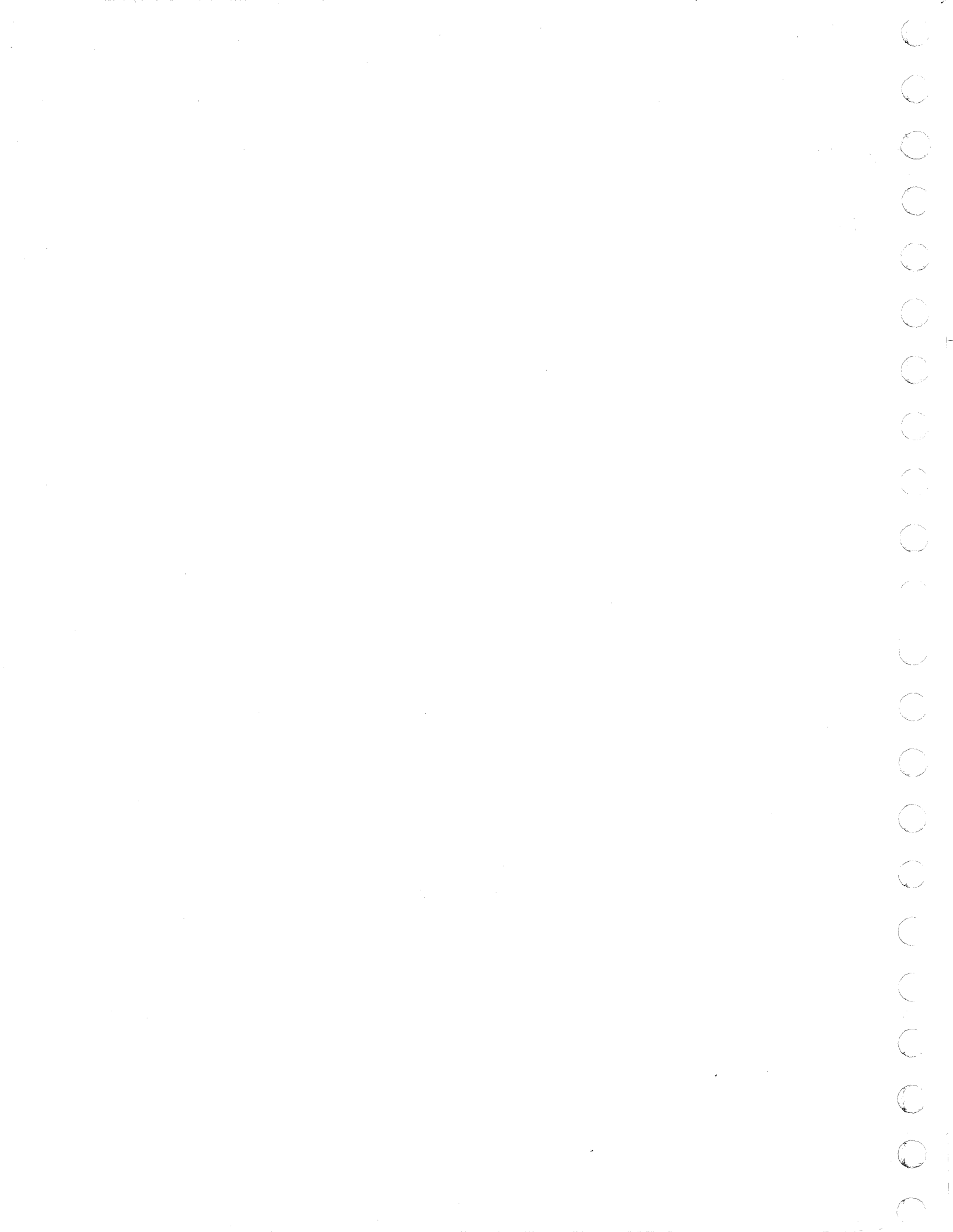

3420/3803 REFERENCE GUIDE

3420/3803 TAPE SUBSYSTEM MAINTENANCE DIRECTORY

FOR EACH DECISION, A LIST OF AVAILABLE MAINTENANCE DOCUMENTATION OR MAINTENANCE PROCEDURES IS PROVIDED

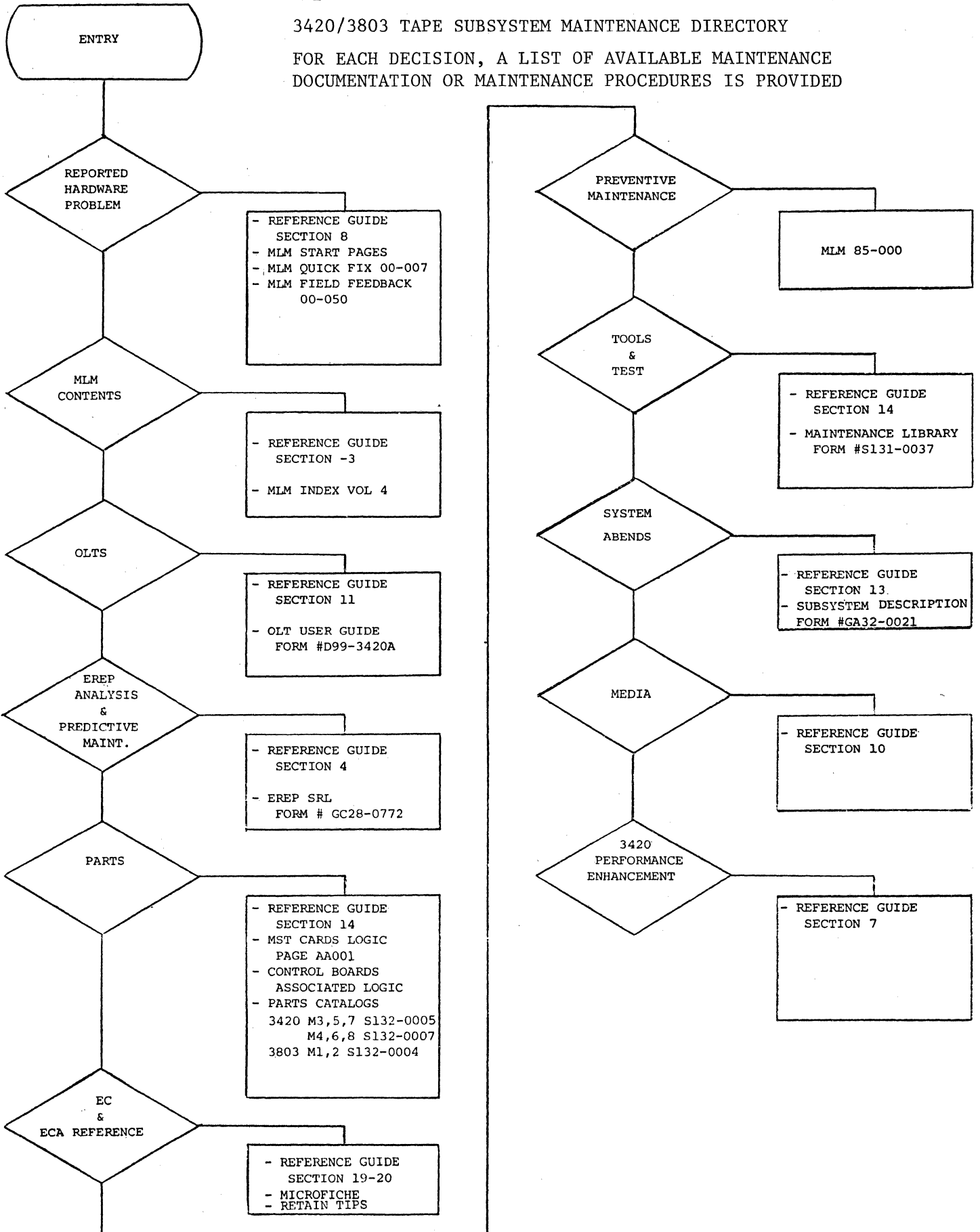



3420/3803 REFERENCE GUIDE

3803/3420 MST BOARD ORDERING

The following information must be supplied when ordering a 3803/3420 MST board for field replacement.

- o Machine type and serial number
- o Part number of the MST board
- o EC level of the board
- o REAs installed (if any)
- o Board location (example - B3)
- o Name and phone number of person to contact in case the plant needs further information

Refer to AA005 (3803) or A6106 (3420) in the logics for feature wiring before installing the board. 3803 MST boards may require installation of tie up/down resistors. See part numbers below.

3803 TIE UP/DOWN RESISTORS:

<u>P/N</u>	<u>Type</u>	<u>Wire Color</u>	<u>Resistance</u>	<u>Tie to Pin</u>
2520936	Tie-Up	Blue	51 ohm	GND (D08, J08, P08, or U08)
2520942	Tie-Down	Yellow	620 ohm	-4V (B06, G06, M06, or S06)

3803 A2 AND B2 BOARD PART NUMBERS

For 3803 Models 1 and 2, board A2 is P/N 2521394. (Note: Board A2 might have factory P/N 1394001 or P/N 1394002 on the label, but these boards cannot be ordered. Use P/N 2521394) The B2 board in the 3803 Models 1 and 2 at EC level 733814 can be P/N1384001, 1384002 or 2521384. Without EC 733814, the correct part of the B2 board is P/N 2521392. Refer to logic page AA005 for wiring that must be added.

3803 MST BOARD REPLACEMENT

The 3803 MST boards contain back panel jumpers that customize the board to the machine in which it is used. The jumper locations are identified on logic page AA005. Boards are shipped without jumpers on them, and problems occur if a board is replaced and the jumpers are not added to the new board.

3803 MST FLAT CABLE REPLACEMENT

- To order a temporary repair cable, use the following procedure:
1. Obtain "Cable Assembly P/N" from the label on the "To" end
(Note: Cables manufactured prior to September 1, 1965 will have all seven digits of the P/N. Cables manufactured after September 1, 1965 have only the last 4 digits. The number "580" can be assumed to be the first three high order digits in all cases).
 2. Determine length by:
 - o Actual length given on "TO" cable label or
 - o Physical measurement of actual cable.
(manufactured before to Sept. 1, 1965)
 3. Ascertain whether the cable being replaced is polyethylene or Teflon covered. Polyethylene is milk-white, Teflon is clear.
 4. Select the correct temporary repair cable from General CEM 251 that is nearest to the length required.
 5. Order the temporary repair cable P/N (obtained from the right hand column in general CEM 251)

LABEL IDENTIFICATION

The following figures describe the information contained on the labels.

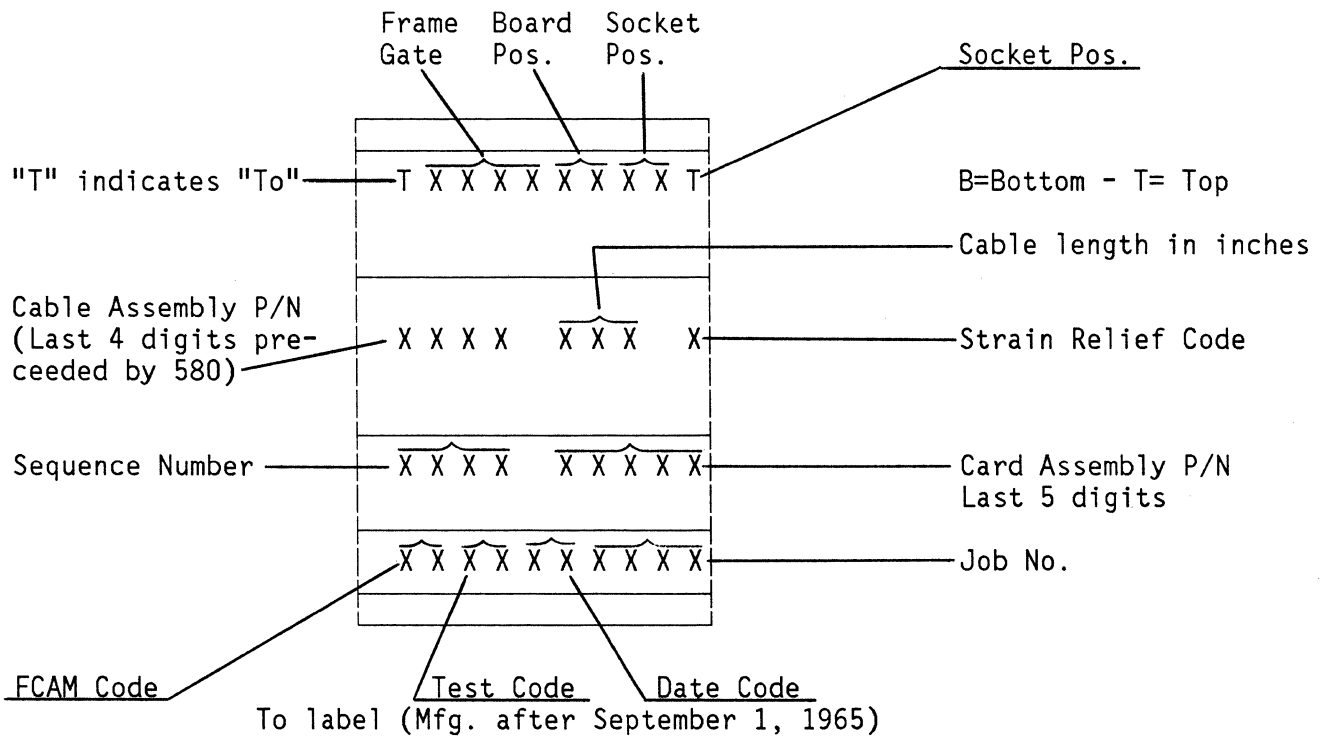

Note: The Test Code and/or Date Code may be missing on cables made between September 1, 1965 and September 18, 1968.

3420/3803 REFERENCE GUIDE

3803 MST FLAT CABLE REPLACEMENT (CONT'D)

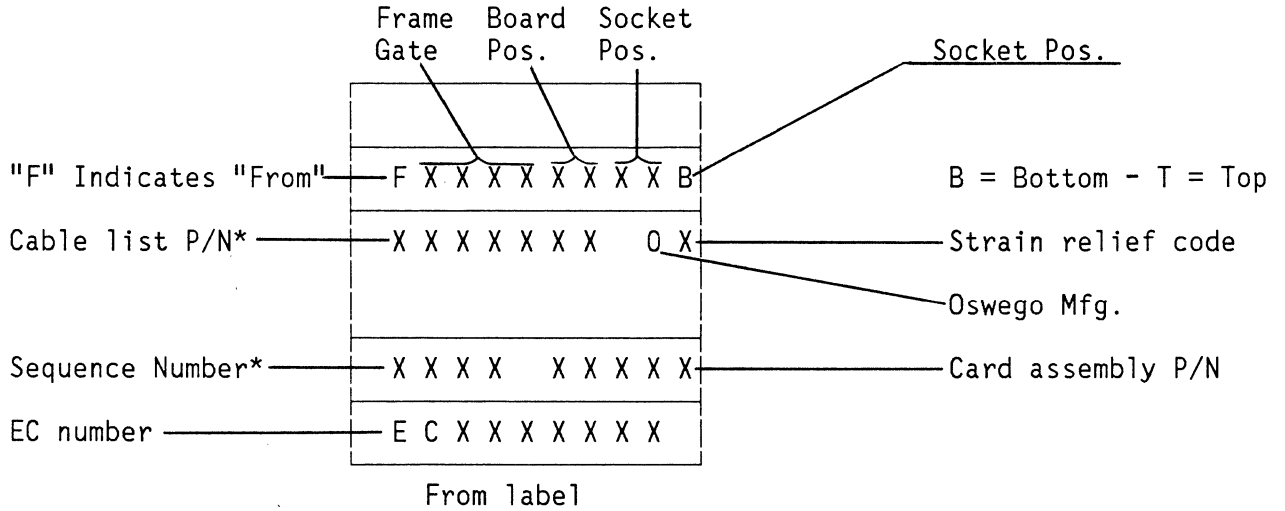

* This information is necessary for ordering new cables, and it must be obtained from the label on the "From" end of the cable.

3420 4,6,8 LOGIC BOARD REPLACEMENT

When replacing logic board 01A, in 3420 Model 4, 6, and 8 tape drives, it is necessary to add wires to the board for model identification and speed. The chart that shows the correct wiring is on logic page A6106 in the 3420 logic manual. Difficult-to-analyze read and write problems will occur if these wires are not added to the board. Also refer to MLM page 08-630, 3420 logic panel removal/replacement.

3420 MST FLAT CABLES REPLACEMENT:

P/N 5802133 uses	P/N 5802180	48 in.
	P/N 5802181	64 in.
P/N 5802134 uses	P/N 5802182	48 in.
	P/N 5802183	64 in.

3803 and 3420 CABLE REQUIREMENTS

A total cable length of 200 feet (unless modified by general control-to-channel cabling schematic) is available to attach up to eight control units. Cable lengths between a 3803 with a 3420 Model 6 or Model 8 attached (at 6,250 bpi) and the channel are shown below.

To	Max Length (ft) With 3420 Model 8 Attached	Max Length (ft) With 3420 Model 6 Attached
2860	72	200
2880	119	200
Block Multiplexer Channel/3800	72*,103	200
Selector Channel	72*,119	200

*On System/370 Model 135/138 and 4331 Processor Model Group 2

For each control unit connected between the 3803 and the channel, the cable length shown must be reduced by 15 feet if 3420 Model 6 is attached, or 20 feet if 3420 Model 8 is attached.

3420/3803 REFERENCE GUIDE

3803-1/3420 MLM/PF DESCRIPTION AND ORGANIZATION

VOLUME I	SECTION
3803-1/3420 Maintenance philosophy	Plan 1
How to use the MAPS	Plan 2
Legend & symbols	Plan 2
MAP formats	Plan 3
Line levels/standard voltages	Plan 5
Status and sense bytes	Plan 6
Acronyms and abbreviations	Plan 7
CE initial entry	Start 1
3803/3420 problem determination	00-010
Permanent read error analysis	00-011
Tape developing procedure	00-014
End of call	00-030
Single tape unit problems	00-040
Mod 3,5,7 Power problem analysis	1A-000
Mod 3,5,7 Drop ready, thread, load failures	2A-000
Mod 3,5,7 Motion, rewind, capstan, reels	3A-000
Mod 3,5,7 Unload problems	4A-000
Mod 3,5,7 R/W problems, envelope failure, runaway	5A-000
Mod 3,5,7 Capstan problems	6A-000
Device interface lines	07-000
Intermittent drop ready problems	07-010
Checks, adjustments, removal and replacements	08-000

3803-1/3420 MLM/PF DESCRIPTION AND ORGANIZATION

VOLUME II	SECTION
OLTEP/OLTSEP problem determination	10-200
Read error analysis	10-430
Velocity error analysis	10-440
Unit check analysis	10-500
Command reject analysis	10-520
Intervention required analysis	10-530
Bus-out check analysis	10-540
Equipment check analysis	10-560
Command or control status reject analysis	10-570
Data check analysis	10-590
TCU power supply failure analysis	11-000
Reset problems	11-005
Offline duplication of online failures	12-000
CE panel operational suggestions	12-001
Procedure for locating a failing command	12-020
Online/offline MP errors or hangs	13-000
Offline test procedures	13-010
System-hangs	13-020
ROS loops on error stops	13-101
How to use sections 15, 16 and 17	14-000
Sense analysis	15-000
Picking/dropping records	15-200
ALU 2 microprogram errors	16-005
Write data checks	17-000
Read data checks	17-005
Write data flow problem information and related MST cards	17-009, 22-007
Read data flow problem information and related MST cards	17-010, 22-009
Diagnostic programs	18-000
Tape runaway	18-006
CU usage meter does not run	18-060
Tape unit will not respond to S10	18-100
Multiple tape unit access problems	18-107
Tape switch support information	18-110
Channel/CU interface problems	18-200
01t section A command sequence chart	19-001
3803-1/3420 data flow block diagram	19-002
Status and sense bytes	19-003

3420/3803 REFERENCE GUIDE

Field tester	19-004
Diagnostic techniques	19-008
MST and cross-reference	19-009
Exchangeable cards, 3803	19-023
Board layouts for the TCU and TU boards	19-026
Tools and test equipment	20-000
Sense byte 7 or 10 extraction	20-005
Local storage register (LSR) display procedure	21-001
CE panel switch and indicator functions	22-000
CE panel data security erase procedure	22-005
Service aids	23-000
Subsystem preventive maintenance	85-000

3803-2/3420 MLM DESCRIPTION AND ORGANIZATION

VOLUME I	SECTION
3803-2/3420 Maintenance philosophy	Plan 1
Acronyms	Plan 2
Legend & symbols	Plan 4
Glossary of terms	Plan 5
Organization	Plan 6
MLM tab placement by volume	Plan 7
CE initial entry	Start 1
How to use MAPS	00-000
Status and sense bytes	00-005
Sense bytes not defined in MAPS	00-007
3803-2 Subsystem quick fix index	00-009
3420/3803 symptom index	00-010
Permanent read/write error analysis	00-014
Develop tape error examples	00-016
End of call	00-030
Abends theory	00-035
Single tape unit problems	00-040
Field feedback	00-050
Mod 3,5,7 Power problem analysis	1A-000
Mos 3,5,7 Drop ready, thread road failures	2A-000
Mod 3,5,7 Motion, rewind, capstan, reels	3A-000
Mod 3,5,7 Unload problems	4A-000
Mod 3,5,7 R/W problems, envelope failure, runaway	5A-000
Mod 3,5,7 Capstan problems	6A-000
Mod 4,6,8 Power problem analysis	1B-000
Mod 4,6,8 Drop ready thread load failure	2B-000
Mod 4,6,8 Motion and rewind failures	3B-000
Mod 4,6,8 Unload failures	4B-000
Mod 4,6,8 R/W failures, envelope failure, runaway	5B-000
Mod 4,6,8 Tape motion, capstan failure	6B-000

3420/3803 REFERENCE GUIDE

3803-2/3420 MLM DESCRIPTION AND ORGANIZATION

VOLUME II	SECTION
Device interface lines	07-000
Intermittent drop ready	07-010
Checks, adjustments, removals, and replacements	08-000
TCU power supply MAPs	11-000
Offline duplication of online failures	12-000
Extracting sense data	12-001
3803 CE panel operation and data flow	12-010
MAP procedures for ALU hangs or loops, channel busy, timeout, or other indications where the microprogram does not appear to be looping normally (possibly also causing channel hang)	13-000
Manual analysis of sense data using a prioritized scheme	14-000
MAP procedures for miscellaneous errors	15-010

3803-2/3420 MLM DESCRIPTION AND ORGANIZATION

VOLUME III	SECTION
Microprocessor diagnose, loop, and scoping procedure	16-000
A. Determine the failing instruction address	
B. Make ALU loop on an error	
C. General reference information	
Microprocessor card interchange list	16-001
A. Long and short instruction cycle timing chart	
Sense bit MAP procedures for equipment checks	16-010
Sense bit MAP procedures for data checks, including timing charts of various data operations plus second levels of the conditions required to produce the error	17-010
1X8 selection logic MAP	18-000
Device switch theory and MAPs for problems isolated to the device switch.	18-010
Tape control channel interface problems	18-040
Extra or missing interrupt	18-050
Tape control metering problems	18-060
Board layouts for the TCU and TU boards showing the functions performed for each card to assist in card swapping.	19-000
Logic net cross-reference list. The MAP scoping procedures allow you to identify a failing line and the FRU from which this line originates. If replacing that FRU does not correct the problem, you may suspect a loading problem at the other end of the line (net). This cross-reference list provides the references to logic for all line (net) names encountered in the MAPs so that you may more easily pursue problems of this nature.	20-000
OLTEP error message analysis. Used as directed by sense analysis sections 3420RO and WR after certain errors encountered by sections 3420 F and G.	21-000

3420/3803 REFERENCE GUIDE

3803-2/3420 MLM DESCRIPTION ORGANIZATION

VOLUME IV	SECTION
Subsystem characteristics, features, etc.	40-000
Control unit data flow	50-000
Channel Tag in/Bus in regs	52-040
Microprocessor information and instructions	
Specific circuits, oscillator through read cycle controls	53-005
Device interface, command types, channel priority	54-000
Loop write to read, recording technique, and common MP routines	55-005
NRZI, translate, data convert	57-006
Two-channel switch (MIS) and device switch theory (TCS) 2x8, 3x8, etc.	58-005
CE panel-description of switches and indicators	75-001
Tools and Test Equipment list	80-000
PM procedures and schedules	85-000
Subsystem installation procedures	90-000
Field tester conversion	90-170
Index (detailed index volumes 1 through 4)	Index-1



EREP AND PREDICTIVE MAINTENANCE

Predictive maintenance is the process of detecting a trend of reduced system or product performance, and fixing the problems to restore proper performance.

Predictive maintenance has been proven to reduce repair actions (RA), CE hours, and maintenance parts costs, as well as to maintain a high level of customer satisfaction.

EREP is the tool used to observe the level of performance. A series of reports entitled; the Tape Subsystem Exception Reports, will be used to assist with the predictive maintenance. These reports are generated by EREP 1.3 that has the customer ordered enhancements installed (refer to announcement letter #282-215, dated 15 OCTOBER 1982).

The following pages describe the Subsystem Exception Reports and how they can be used to do predictive maintenance.

SUBSYSTEM EXCEPTION REPORTS THAT ARE AVAILABLE FOR TAPE

- o Subsystem Exception Tape 4.3
- 5 exception categories.
- o Tape Permanent Error Summary 4.15
- Sense bytes, explanation and other data for each failure.
- o Tape Temporary Error Summary 4.16
- Total temporary errors for each subsystem device.
- o Tape CUA Statistics Summary for -CUA 4.19
- A report for each CUA that was an exception. Shows statistics of each demount.
- o Tape Volume Statistics Summary 4.21
- Statistics for each exception volume mount are listed.

The detailed content of these reports is explained on the following pages. Much of this material has been taken from; ENVIRONMENTAL RECORDING EDITING AND PRINTING (EREP) PROGRAM, GC28-0772-6, as revised 1 September 1982.

SUBSYSTEM EXCEPTION TAPE			REPORT DATE 174 82 PERIOD FROM 170 82 TO 171 82											
1			----- 3420 -----				----- 3410 -----							
2			1600 BPI		6250 BPI		1600 BPI		1600 BPI					
CURRENT LIMITS HBYTES/ERR(CT)			HARDWARE VOLUME	TEMP WRT(CT)	TEMP RD(CT)	TEMP WRT(CT)	TEMP RD(CT)	TEMP WRT(CT)	TEMP RD(CT)	TEMP WRT(CT)	TEMP RD(CT)			
3			4	5	6		7	8	9	10		11	12	
EXCEPTION	VOLUME SERIAL	ADDR	C P EQU U	CHK	MB/ERR READ(CT)	PERM WRITE(CT)	MB/ERR WRITE(CT)	TEMP READ(CT)	BUS OVR OUT RUN	SIOCOUNT	TOTAL-MBYTES READ	WRITE	DEN-SITY	HDR SER
HARDWARE PERMANENT ERROR														
	988	A	2		-- (0)	-- (0)	164(7)	-- (0)	0 0	178K	820	1154*	6250	
	37E	A	0		28(1)	-- (0)	-- (0)	-- (0)	0 0	61K	28	632*	1600	
	37D	A	0		-- (0)	482(1)	-- (0)	-- (0)	0 0	84K	418	482*	6250	
HARDWARE FAILED TEMPORARY READ OR WRITE LIMITS														
	3C2	A	0		-- (0)	-- (0)	0(27)	-- (0)	0 0	1K	0	16*	1600	
VOLUME OR CREATING DRIVE PERMANENT READ OR WRITE ERRORS OR RESET KEY ON MORE THAN ONE DRIVE														
	079699	992	A	0	0(2)	-- (0)	-- (0)	-- (0)	0 0	90	1	0*	--	04420
VOLUME OR CREATING DRIVE FAILED TEMPORARY READ OR WRITE LIMITS ON MORE THAN ONE DRIVE														
	050971	981	A	0	-- (0)	-- (0)	0(10)	8(4)	0 0	4K	35	8*	--	05662
VOLUME FAILED TEMPORARY READ OR WRITE LIMITS														
	051007	3C2	A	0	-- (0)	-- (0)	0(1)	0(4)	0 0	37	0	0*	--	
TOTAL NUMBER OF DRIVES ON REPORT					4 (12%)		TOTAL NUMBER OF VOLUMES USED =		457					
NOT ON REPORT					30 (88%)		TOTAL NUMBER OF VOLUMES LISTED =		3					
(*) AN AVERAGE BLOCK LENGTH WAS USED BECAUSE A ZERO BLOCK LENGTH WAS FOUND IN ONE OR MORE D2R RECORDS														
AVERAGE BLOCK LENGTH = 10742														
CPU	MODEL	SERIAL NUMBER												
A	3033	707070												
B	3033	808080												

Figure 4.1 Tape Subsystem Exception Report

TAPE SUBSYSTEM EXCEPTION REPORT

This report indicates if the tape subsystem has permanent errors, or is operating within acceptable limits. You specify LIMIT controls for both hardware and volume to prevent the printing of excessive temporary errors. See "LIMIT Control Statement" on page 4.23. When you do not specify limits for temporary errors, only permanent errors appear on the exception report.

NOTES: (The item numbers below refer to the block numbers in fig. 4.1)

1. ****WARNING****: A message appears here if the input records span more than 3 days. The problem causing the error might already have been fixed.
2. **CURRENT LIMITS**. These two lines show the limits set in the LIMIT control statements included when the report was requested. The limits are set for temporary read and write errors occurring in the HARDWARE (device) and on the VOLUME. They prevent the printing of all temporary errors except those that occurred at the specified frequency level.

In the tape reports, the current limits are grouped under device type (3420 and 3410), tape density (1600 BPI and 6250 BPI), and TEMP WRT and TEMP RD. They show the specified number of megabytes read or written per error (MBYTES/ERR) and the specified total number of errors recorded (CT). In the example report (figure 4.1), temporary write errors recorded against a 3420 drive (hardware) at a density of either 1600 or 6250 BPI will not appear as exceptions unless there are at least 15 errors occurring at a rate of 1 or more errors in each 4 megabytes of data written. Temporary read errors on a 3420 at either density will qualify as exceptions if there are 2 or more errors occurring at a rate of 1 or more errors in each 26 megabytes of data read.

3. **EXCEPTION.** Errors are in this report by exception type; the type of exception serves as an indicator of the suspected source of the problem. The Subsystem Exception Tape report consists of 5 major headings, with exception categories. They are:
- o Hardware
Permanent Error 4.6
 - o Hardware
Failed Temporary Read or Write Limits 4.7
 - o Volume or Creating Drive
Permanent Read or Write Errors or
Reset Key on More Than One Drive 4.9
 - o Volume or Creating Drive
Failed Temporary Read or Write Limits
on More Than One Drive 4.12
 - o Volume
Failed Temporary Read or Write Limits 4.14

Each exception indicated under the above headings, must be investigated to insure satisfactory performance of the tape subsystem. The descriptions contained in this guide, will help you understand the meaning of the exceptions. In addition, a technique for analyzing each exception report category is provided.

If this Subsystem Exception Report indicates that corrective action is necessary, the four tape reports that follow, (Tape Permanent Error Summary, Tape Temporary Error Summary, Tape CUA Statistics Summary for -CUA, and Tape Volume Statistics Summary) are used to provide additional information to assist with the analysis of each exception example.

3420/3803 REFERENCE GUIDE

4. **ADDR.** This column contains the CUAs (channel/unit addresses) against which the permanent and temporary errors were recorded.
5. **EQU CHK.** Count of equipment checks.
6. **MB/ERR PERM and MB/ERR TEMP.** These columns list the actual numbers of errors recorded during the report period, and the actual error rate, for this CUA. In the example, CUA 37E recorded 1 permanent read error in 28 megabytes of data read: CUA 9B8 recorded a total of 7 temporary write errors in 164 megabytes of data written.
7. **BUS OUT.** The bus out check count from the statistical data recorded (SDR) counters.
8. **OVR RUN.** The overrun count from the SDR counters.
9. **SIOCOUNT.** The number of START I/O instructions issued against this CUA during the report period, in thousands.
10. **TOTAL MBYTES READ WRITE.** The total number of megabytes read or written during the report period.
11. **DENSITY.** The tape density, from the mode byte in the OBR record.
12. **HDR SER.** The serial number of the creating drive, from the tape header.
13. Number of drives (hardware) and volumes appearing on this report, in comparison to the total drives and volumes.
14. This area identifies the model and serial number of the CPU(s) which have been designated elsewhere in this report by a letter.

TAPE SUBSYSTEM EXCEPTION REPORT ANALYSIS

The following pages describe a technique for performing the analysis of the Tape Subsystem Exception Report. Each heading will be described separately.

EXCEPTION

HARDWARE

Permanent Error

The CUAs listed have encountered at least one permanent error during the reporting period. The temporary performance is also indicated for each failing CUA. Additional details about the permanent errors are contained in the report entitled, Tape Permanent Error Summary.

For an explanation of the details contained in the "Tape Permanent Error Summary" report, see page 4.15.

ERROR ANALYSIS

- o Note the type of permanent error.
Is it an equipment check, read, or write?
- o Refer to the "Tape Permanent Error Summary" report and note the explanation of the error.
- o Use the 3803/3420 MLM index (volume 4) or sense byte chart (MLM 00-005), to locate the associated map.
- o CAUTION: A PROBLEM THAT IS REPORTED AS A SINGLE 3420 FAILURE, DOES NOT USUALLY INDICATE THE NEED TO REPLACE ANY OF THE 3803 FRUs.
- o Do 3420 checks and/or adjustments as suggested.
- o The following aids are available for help in further analysis:

Field Feedback	MLM-00-050
Quick Fix	MLM-00-009
Sense Analysis	MLM-14-000
Sense Byte Chart	MLM-00-005
Symptom Index	MLM-00-010

3420/3803 REFERENCE GUIDE

EXCEPTION

HARDWARE

Failed Temporary Read or Write Limits

The CUAs listed have temporary errors exceeding the current limits (Note 1). The EREP program has determined that the listed drives did not perform to the current limits with various tape volumes mounted.

Note 1:

The temporary read, write limits used to determine the exceptions in this category, are coded by the CE using the LIMIT control statements. Refer to page 4.23 for details.

ERROR ANALYSIS

Refer to the flowchart on page 4.8 and follow the directions.

ANALYSIS OF HARDWARE FAILED TEMPORARY READ OR WRITE LIMITS

CHART 1

RD/WRT	MOTION
EWV/VRC	SRC/PC
MTE/LRC	VEL CHG
EDC/CRC	PAR/TACH
SKREW ERR	
R/W VRC	
WTM CHK	

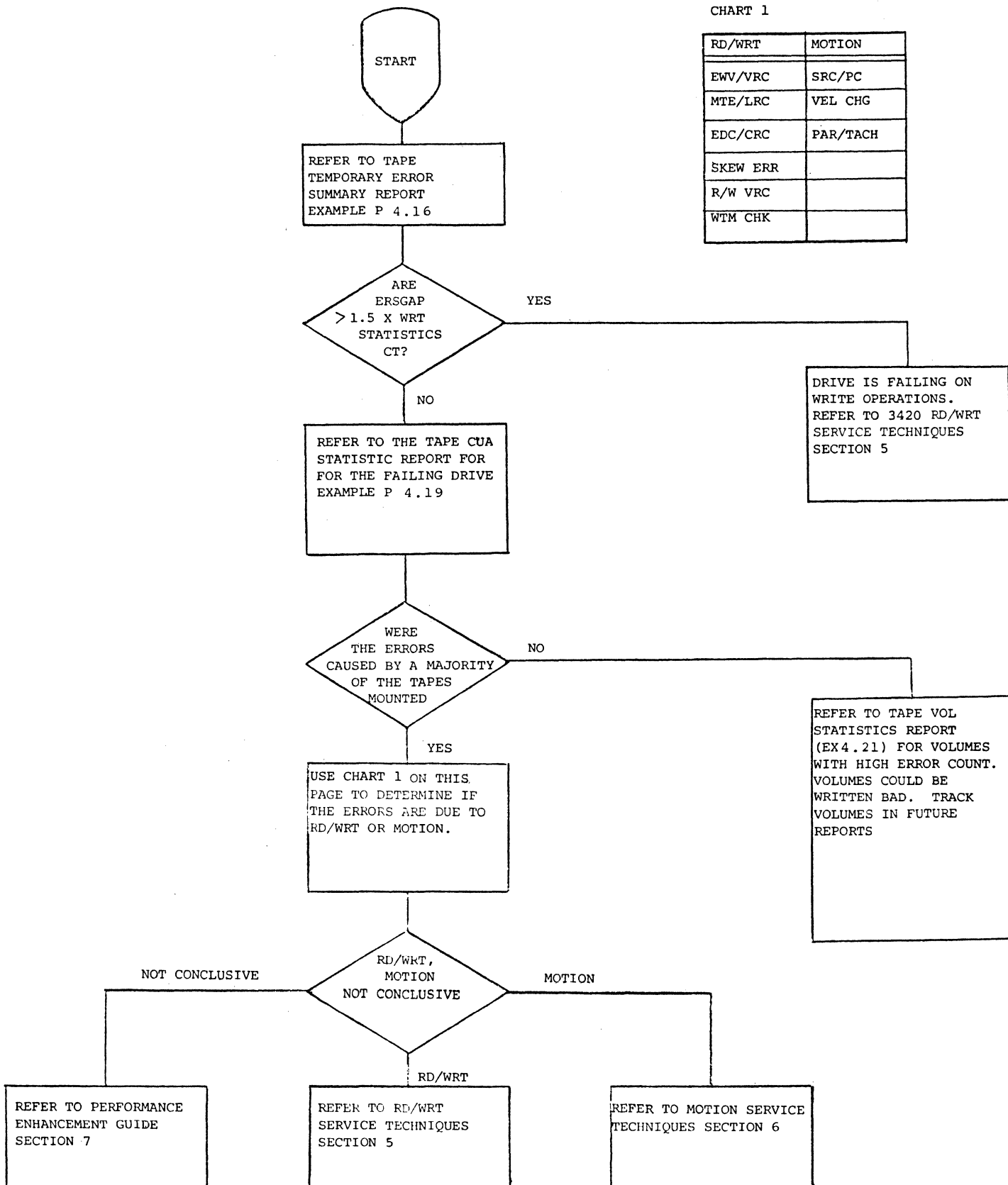

EXCEPTION

VOLUME OR CREATING DRIVE

Permanent Read or Write Errors or Reset Key
on More Than One Drive

All tape volumes listed, failed with a permanent error on more than one drive. Additional details about the permanent are contained in the reports entitled, Tape Permanent Error Summary and Tape Volume Statistics Summary.

For an explanation of the details contained in the "Tape Permanent Error Summary" report, see page 4.15; and for the "Tape Volume Statistics Summary" report, see page 4.21.

ERROR ANALYSIS

Permanent Read errors indicate that the volume was created in error or that the tape was damaged after creation.

Permanent Write errors usually indicate that it is not possible to write the 6250 load point format SAGC or ID burst. This is caused by damaged tape in the load point. Damage anywhere else on the tape would indicate that damage was across 15 erase gap areas, which is approximately 50 inches of tape. This is caused by the way the IOCS Tape Error Handler forces a backspace, erase gap, and rewrite sequence 15 times, before a permanent write error is recorded.

Refer to the flowchart on page 4.10 and follow the directions.

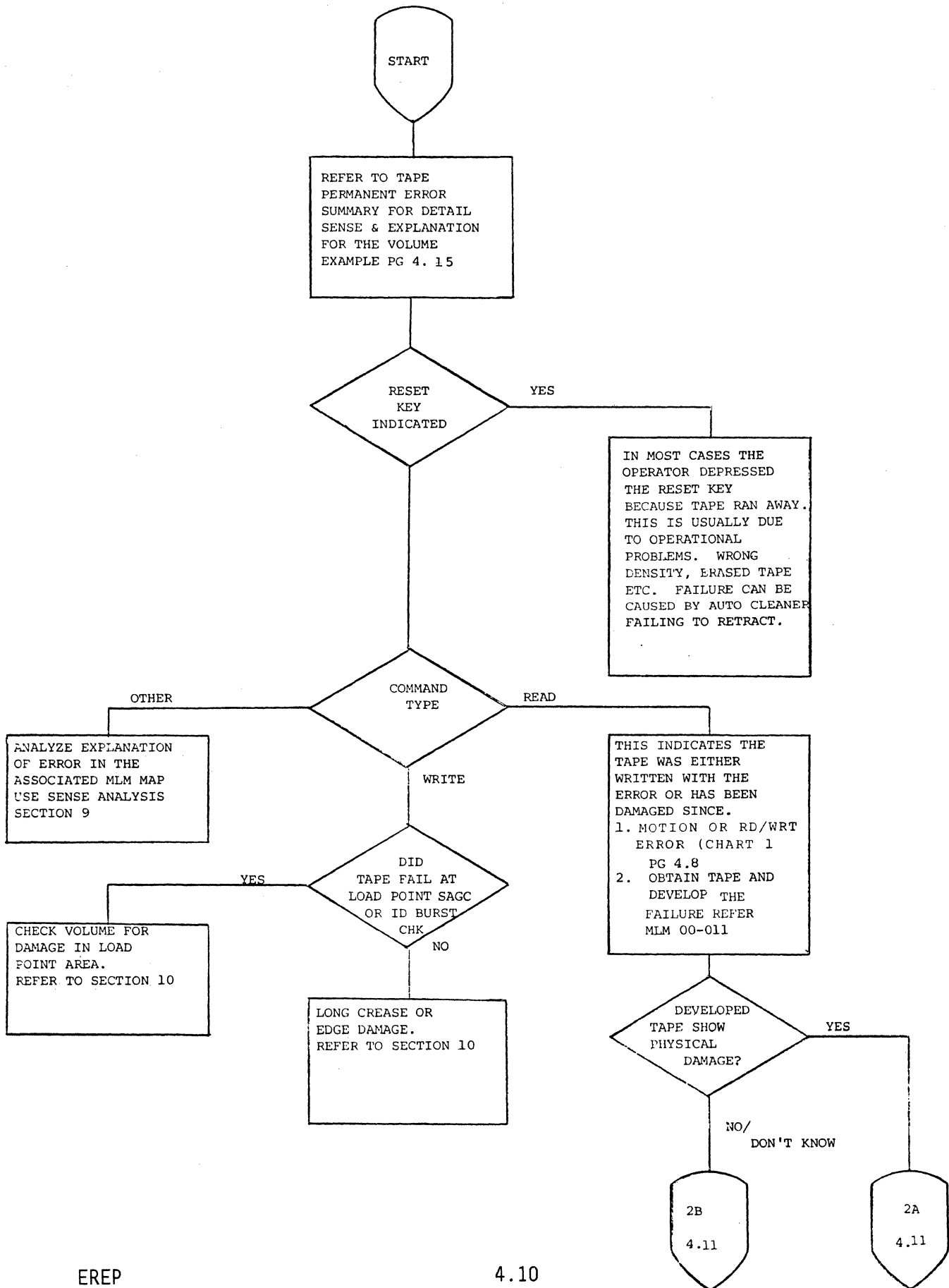

3420/3803 REFERENCE GUIDE

VOLUME OR CREATING DRIVE PERMANENT READ, WRITE, OR RESET KEY ON MORE THAN ONE DRIVE

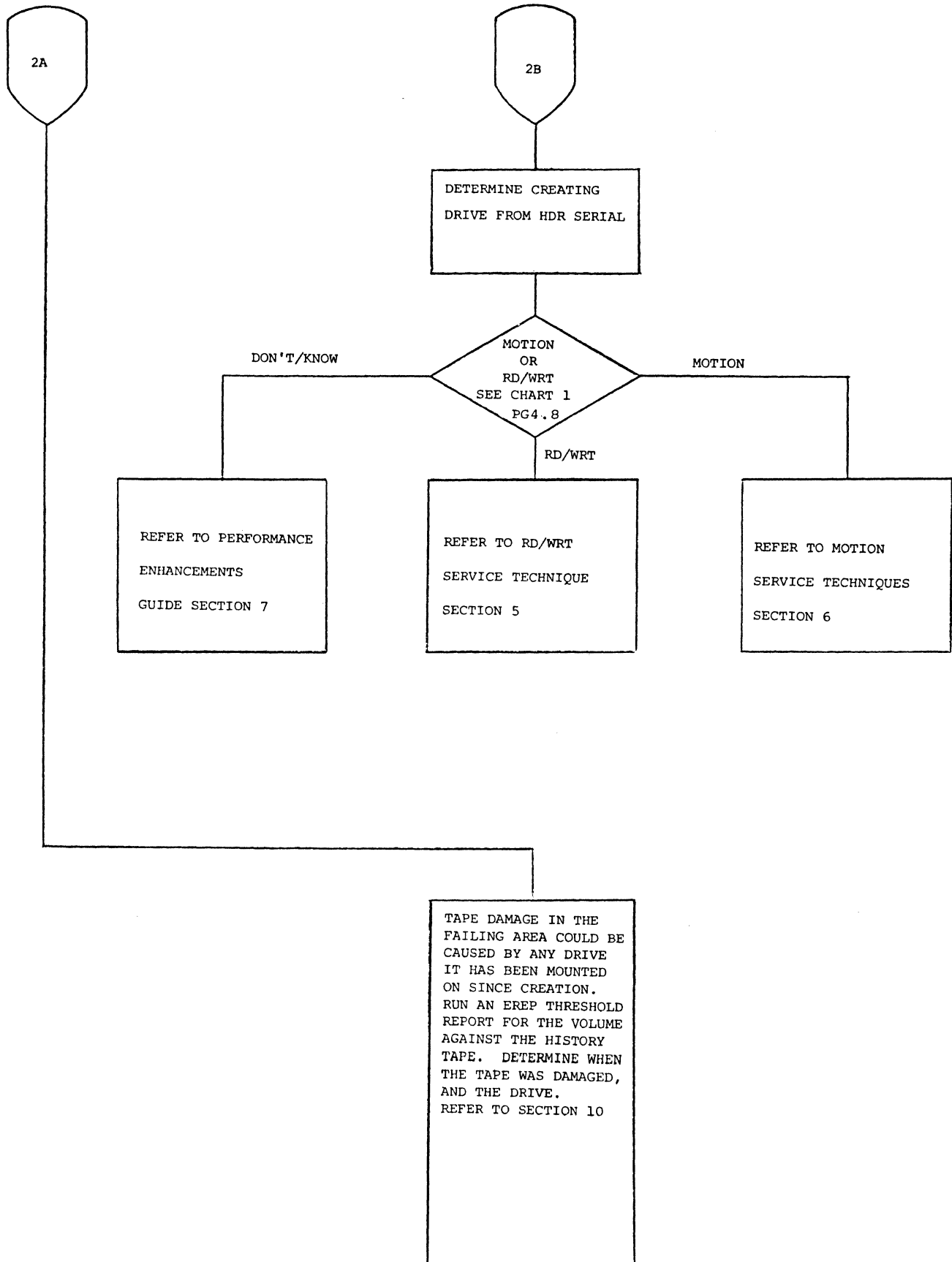

EXCEPTION

VOLUME OR CREATING DRIVE

Failed Temporary Read or Write Limits
on More Than One Drive

Volumes listed did not perform to the current limits (Note 1) on more than one drive.

Note 1:

The temporary read, write limits used to determine the exceptions in this category, are coded by the CE using the LIMIT control statements. Refer to page 4.23 for details.

ERROR ANALYSIS

If the failures are temporary read errors, then the tape was either written in error by the creating drive or the tape was damaged in an operation that followed.

If the failures are temporary write errors, then the tape volume has excessive damage.

Refer to the flowchart on page 4.13 and follow the directions.

3420/3803 REFERENCE GUIDE

VOLUME OR CREATING DRIVE FAILED TEMPORARY READ OR WRITE LIMITS ON MORE THAN ONE DRIVE

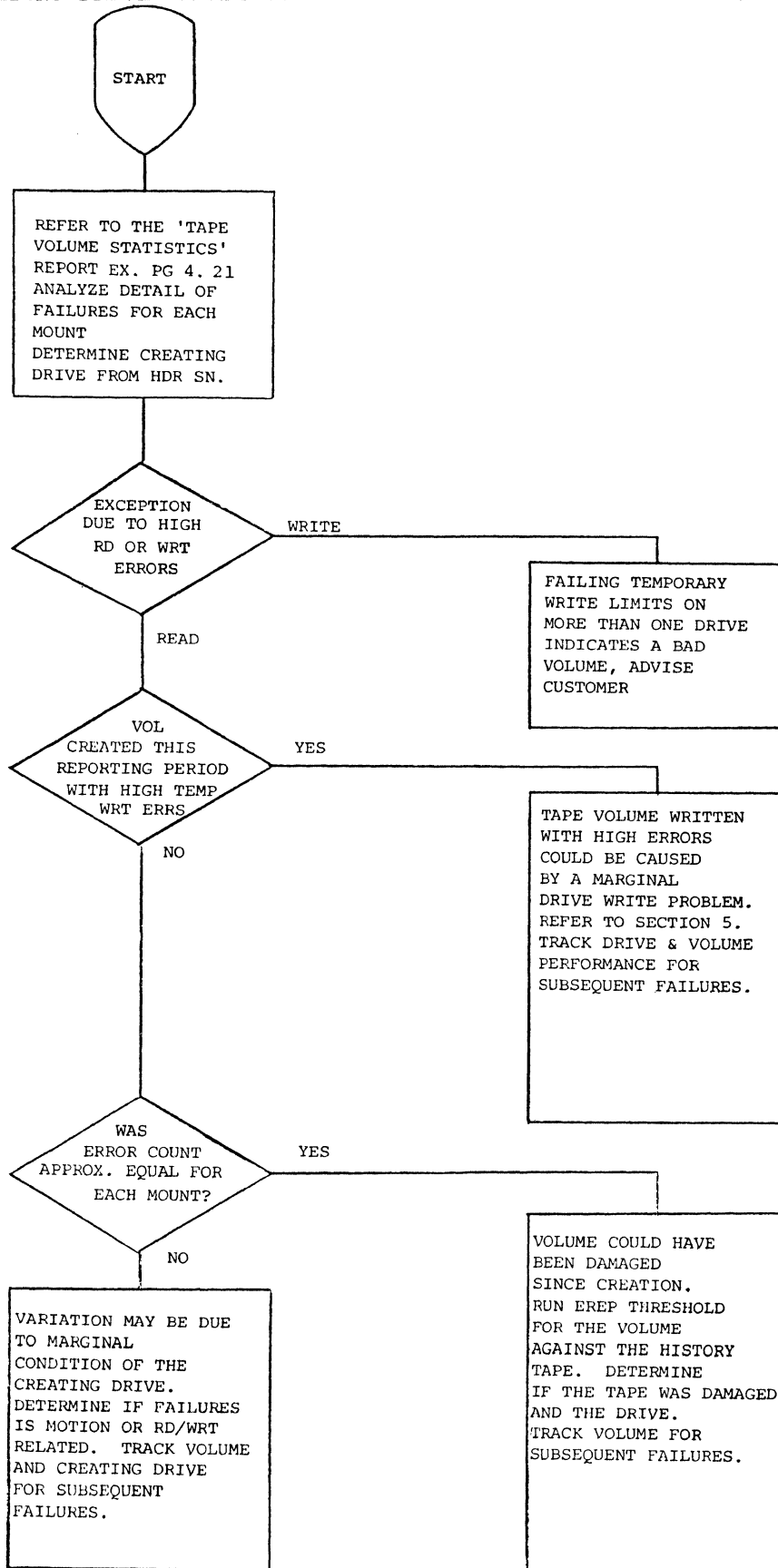

EXCEPTION
VOLUME

Failed Temporary Read or Write Limits

All CUAs that failed to perform to the limits set, are listed here. There is not enough data to classify the failure as hardware or volume.

ERROR ANALYSIS

Tracking and analysis of later reporting period failures are required.

For further analysis, run an EREP threshold report against the history tape for the volume or CUA in question.

TAPE PERMANENT ERROR SUMMARY										REPORT DATE 174 82									
										PERIOD FROM 170 82									
										TO 171 82									
C	P	1	2	3	4	5	6	7											
CUA	U	DTE	TIME	VOLID	R	E	CMD	FLG	CNT	CSW32-63	0	4	8	1	2	0	EXPLANATION	HDR	SER
**** HARDWARE ****																			
37D	B	170	222258	058902		01	20000050	0E00002E	00440004	00502D00	00080000	00125C1A	E9826000	011A0008	ID BURST CK			08738	
37E	A	170	170457	086481	R	02	20000050	0E000050	02C00004	00482D00	00080000	0002B11A	EAF16009	191A0002	START RD CHECK			05892	
988	A	171	232327	076803	E	17	00000000	26000001	50203002	42403D20	00080000	00158302	26F13000	09180010	TAPE BOTTM RGHT			08995	
988	A	171	233624	076803	E	01	64002EFC	0E002EFB	50200000	42403D20	00080000	00158302	26F13000	09180010	TAPE BOTTM RGHT			09014	
**** VOLUME OR CREATING DRIVE ****																			
3CS	A	171	112908	079699	R	02	64002000	0E00106A	02C0FFC8	00443D00	00820000	0028AF0A	12B16000	141A00FA	PARTIAL RECORD			04393	
992	B	171	114445	079699	R	02	64002000	0E00102B	08C0CAC8	00443D00	00820000	00D1AE17	09E16040	091A00FA	PARTIAL RECORD			04420	
NOTE: TO CONVERT 'HDR SER' TO 'CUA' USE 'TAPE UNIT SER' IN 'TAPE TEMPORARY ERROR SUMMARY' (NEXT REPORT).																			
CPU	MODEL	SERIAL NUMBER																	
A	3033	707070																	
B	3033	808C20																	

Figure 4.2 Tape Permanent Error Summary

Tape Permanent Error Summary

This report describes in more detail, the permanent errors that appear on the Tape Subsystem Exception report. The errors are grouped under either hardware or volume/creating drive, and are listed by CUA or VOLID (volume serial number) in the order that they occurred.

Notes:

1. R W E. These letters indicate which kind of permanent error is involved: READ, WRITE, or EQUIPMENT CHECK.
2. CMD. The command code from the CCW in the OBR record.
3. FLG. The flag byte from the CCW in the OBR record.
4. CNT. The byte count from the CCW in the OBR record.
5. CSW32-63. Bits 32 - 63 of the CSW in the OBR record.
6. SENSE. The sense bytes from the OBR record.
7. HDR SER. The serial number of the creating drive.

TAPE TEMPORARY ERROR SUMMARY										REPORT DATE 174 82		7																
										PERIOD FROM 170 82																		
										TO 171 82																		
1	2	3	4	5		6		7																				
CUA	UNIT SER	DEN- SITY	TOTAL SIOS	TOTAL MOUNT	WRITE STATISTICS MB/ERR(CT)	ERSOAP	READ STATISTICS MB/ERR(CT)	CLNACT	ENV VRC	MTE LRC	SRC /PC	EDC CRC	VEL CHG	SKEW ERR	R/W VRC	WTH CHK	PAR/ TACH	OVER RUN	ISO DET									
37D	76889	A	6250	83795	24	48(10)	-10	139(3)	0	13	8	0	3	1	2	8	0	0	0	0								
37D	76889	A	OTHER	17	3	-- (0)	0	-- (0)	0	0	0	0	0	0	0	0	0	0	0	0								
37E	76890	A	6250	96665	18	199(3)	3	-- (0)	0	3	2	0	0	0	2	0	0	0	0	0								
37E	76890	A	1600	61431	48	4(149)	231	14(2)	18	149	26	2	11	0	4	0	0	0	0	1								
37E	76890	A	OTHER	3667	16	-- (0)	0	-- (0)	0	0	0	0	0	0	0	0	0	0	0	0								
3C2	59146	A	6250	210776	34	82(18)	15	64(12)	0	17	10	0	2	1	4	10	1	0	0	1								
3C2	59146	A	1600	1491	3	0(27)	28	-- (0)	0	27	1	0	1	0	1	0	0	0	0	0								
3C2	59146	A	OTHER	74	6	-- (0)	0	-- (0)	0	0	0	0	0	0	0	0	0	0	0	0								
992	75897	A	6250	108436	35	32(31)	30	150(1)	18	31	29	0	4	0	1	29	1	1	0	1								
992	75897	A	OTHER	3778	6	-- (0)	0	-- (0)	0	0	0	0	0	0	0	0	0	0	0	0								
981	N/A	A	6250	754811	75	105(33)	33	3(1353)	2800	23	1K	73	54	1	27	1K	61	47	50	2								
981	N/A	A	OTHER	152962	28	-- (0)	0	958(1)	0	1	1	0	0	0	1	0	1	0	0	0								
988	40550	A	6250	178336	37	48(24)	25	273(3)	0	24	22	0	3	2	3	22	0	0	0	0								
988	40550	A	1600	174	1	-- (0)	0	-- (0)	0	0	0	0	0	0	0	0	0	0	0	0								
988	40550	A	OTHER	31674	6	-- (0)	0	-- (0)	0	0	0	0	0	0	0	0	0	0	0	0								
6250BPI TOTALS:			1432817	223	(119)	116	(1372)	2836																				
1600BPI TOTALS:			63096	52	(176)	259	(2)	18																				
OTHERBPI TOTALS:			192172	65	(0)	0	(1)	0																				
TOTALS:			1688085	340	(295)	375	(1375)	2854																				
9																												
AVERAGE MEGABYTES/TEMPORARY READ ERROR = 59																												
AVERAGE MEGABYTES/TEMPORARY WRITE ERROR = 422																												
AVERAGE MEGABYTES/PERMANENT READ ERROR = 40374																												
AVERAGE MEGABYTES/PERMANENT WRITE ERROR = --																												
AVERAGE MEGABYTES/PERMANENT ERROR = 102657																												
TOTAL MEGABYTES PROCESSED = 205314																												
TOTAL MEGABYTES READ = 80748																												
TOTAL MEGABYTES WRITTEN = 124566																												
CPU MODEL SERIAL NUMBER																												
A 3033 707070																												
B 3033 808080																												

Figure 4.3 Tape Temporary Error Summary

Tape Temporary Error Summary

This report presents all the temporary read/write errors recorded for the hardware during the report period. The LIMIT control values specified when invoking EREP are ignored for this report.

Notes:

1. **CUA and DENSITY** The errors are listed by CUA and density.
2. **TAPE UNIT SER.** The serial number of the tape unit. If this information is not available because the CUA did not have a permanent error, N/A will appear in this field.
3. **TOTAL SIOS.** The number of SIOs issued against this device at this density.

4. **TOTAL MOUNT.** The number of volume mounts for this device at this density.
5. **WRITE STATISTICS.** This area lists the actual number of megabytes written per temporary write error, and the actual number of temporary write errors, by this device at this density. The total number of erase gaps on this device at this density, are listed under the ERSGAP heading.
6. **READ STATISTICS.** This area lists the actual number of megabytes per temporary read error, and the actual number of temporary read errors. The total number of cleaner actions on this device at this density, are listed under the CLNACT heading.
7. These eleven columns contain counts from the statistical data that is recorded in the OBR records, as follows:

ENV VRC	total envelope/vertical redundancy check count
MTE LRC	total multitrack error/longitudinal redundancy check count
SRC/PC	for 3420, the total start read check count; for 3410, the total parity compare count
EDC CRC	total end data check/cyclic redundancy check count
VEL CHG	total velocity change count
SKEW ERR	total skew error count
R/W VRC	total read/write vertical redundancy check count
WTM CHK	total write tape mark check count
PAR/TACH	for 3420, the total partial record count; for 3410, the total tach check count
OVER RUN	total overrun count
IBG DET	total interblock gap detected count

8. Totals of SIOs, mounts, write, and read statistics for each tape density.
9. Averages and totals for megabytes of data processed during the report period.

TAPE CUA STATISTICS SUMMARY FOR - 988

REPORT DATE 174 82
 PERIOD FROM 170 82
 TO 171 82

CURRENT LIMITS		HARDWARE		1600 BPI		6250 BPI		3420												
MBYTES/ERR(CT)				TEMP WRT(CT)	TEMP RD(CT)	TEMP WRT(CT)	TEMP RD(CT)													
				4 (15)	26 (2)	4 (15)	26 (2)													
VOLUME	TIME	MB/ERR	TEMP	SIOCOUNT	ENV	MTE	POST	C/P	CRC	WRTG	--SLOW--	CHAN	ERLY	PART	TIE	C	U	DEN-	HR	
SERIAL	DTE	WRITE(CT)	READ(CT)		VRC	LRC	ANBL	COMP	III	VRC	BEG	END	BUFF	BRBC	REC	P 07		SITY	SER	
072681	170 23:20:54	-- (0)	-- (0)	35	0	0	0	0	0	0	0	0	0	0	0	0	0	0	0	0
079115	170 23:50:48	-- (0)	-- (0)	38	0	0	0	0	0	0	0	0	0	0	0	0	0	0	0	0
078698	172 00:40:47	-- (0)	-- (0)	126	0	0	0	0	0	0	0	0	0	0	0	0	0	0	0	0
050298	172 00:46:59	-- (0)	-- (0)	228	0	0	0	0	0	0	0	0	0	0	0	0	0	0	0	0
072212	172 00:57:01	-- (0)	1 (1)	135	0	1	0	0	1	0	0	0	1	0	0	0	0	0	0	0
075397	172 00:58:12	-- (0)	-- (0)	175	0	0	0	0	0	0	0	0	0	0	0	0	0	0	0	0
072727	172 01:13:42	-- (0)	-- (0)	4652	0	0	0	0	0	0	0	0	0	0	0	0	0	0	0	0
060736	172 04:20:23	-- (0)	-- (0)	9110	0	0	0	0	0	0	0	0	0	0	0	0	0	0	0	0
071540	172 05:53:07	-- (0)	-- (0)	44	0	0	0	0	0	0	0	0	0	0	0	0	0	0	0	0
079146	172 07:43:28	-- (0)	-- (0)	5890	0	0	0	0	0	0	0	0	0	0	0	0	0	0	0	0
080281	172 07:55:17	-- (0)	-- (0)	8774	0	0	0	0	0	0	0	0	0	0	0	0	0	0	0	0
030281	172 08:03:26	-- (0)	-- (0)	11568	0	0	0	0	0	0	0	0	0	0	0	0	0	0	0	0
030472	172 08:09:43	-- (0)	-- (0)	18178	0	0	0	0	0	0	0	0	0	0	0	0	0	0	0	0
071573	172 08:28:53	-- (0)	-- (0)	20189	0	0	0	0	0	0	0	0	0	0	0	0	0	0	0	0
071535	172 03:37:08	-- (0)	-- (0)	15059	0	0	0	0	0	0	0	0	0	0	0	0	0	0	0	0
063169	172 08:53:07	-- (0)	-- (0)	16331	0	0	0	0	0	0	0	0	0	0	0	0	0	0	0	0
061915	172 12:01:01	-- (0)	-- (0)	1145	0	0	0	0	0	0	0	0	0	0	0	0	0	0	0	0
075756	172 17:32:54	-- (0)	-- (0)	1724	0	0	0	0	0	0	0	0	0	0	0	0	0	0	0	0
072763	172 17:50:49	-- (0)	27 (2)	5044	0	0	0	0	0	0	0	0	0	0	0	0	0	0	0	0
065746	172 18:10:04	-- (0)	-- (0)	36	0	0	0	0	0	0	0	0	0	0	0	0	0	0	0	0
053273	172 18:53:47	-- (0)	-- (0)	4216	0	0	0	0	0	0	0	0	0	0	0	0	0	0	0	0
054315	172 19:21:56	-- (0)	-- (0)	8942	0	0	0	0	0	0	0	0	0	0	0	0	0	0	0	0
072125	172 19:57:36	-- (0)	-- (0)	111	0	0	0	0	0	0	0	0	0	0	0	0	0	0	0	0
071266	172 20:41:45	-- (0)	-- (0)	40	0	0	0	0	0	0	0	0	0	0	0	0	0	0	0	0
	172 21:10:26	-- (0)	-- (0)	8	0	0	0	0	0	0	0	0	0	0	0	0	0	0	0	0
051956	172 21:19:24	-- (0)	-- (0)	246	0	0	0	0	0	0	0	0	0	0	0	0	0	0	0	0
065161	172 21:32:50	18 (3)	-- (0)	5030	3	3	0	0	0	0	0	0	1	3	0	0	0	0	0	0
066514	172 21:40:53	56 (1)	-- (0)	5170	1	1	0	0	0	0	0	0	1	3	0	0	0	0	0	0
025034	172 22:00:05	-- (0)	-- (0)	19	0	0	0	0	0	0	0	0	0	0	0	0	0	0	0	0
076203	172 23:23:27	E 24 (7)	-- (0)	12989	8	8	0	0	2	0	0	5	8	0	0	0	0	0	0	0
076203	172 23:33:38	-- (0)	-- (0)	0	0	0	0	0	0	0	0	0	0	0	0	0	0	0	0	0
075203	172 23:36:24	E -- (0)	-- (0)	12966	0	0	0	0	0	0	0	0	0	0	0	0	0	0	0	0
063035	173 00:47:24	-- (0)	-- (0)	21967	0	0	0	0	0	0	0	0	0	0	0	0	0	0	0	0

COLUMN TOTALS: (11) (3) 190185 12 13 0 0 3 0 0 6 13 0 0

TOTALS: MOUNTS = 32
 AVERAGE MEGABYTES/TEMPORARY READ ERROR = 333
 AVERAGE MEGABYTES/TEMPORARY WRITE ERROR = 55

CPU MODEL SERIAL NUMBER
 A 3033 707070
 B 3033 808030

Figure 4.4 TAPE CUA STATISTICS SUMMARY

Tape CUA Statistics Summary

One of these reports is generated for each device (CUA) that appears as a hardware exception on the Tape Subsystem Exception report. The report presents the CUA's temporary errors that failed the limits set in the LIMIT control statements. The errors appear by volume serial number in the order (date and time) in which they occurred.

Notes:

1. **CURRENT LIMITS.** Because the report deals with temporary errors, the current LIMIT values for hardware appear for comparison.
2. **DTE.** The date and time are from the OBR record.
3. **R W E.** This column contains the permanent errors against this volume. An R indicates read errors, a W indicates write errors, and an E indicates equipment checks.
4. **MB/ERR TEMP.** The actual error count and error frequency for this volume mount.
5. **SIOCOUNT.** The number (from the OBR record) of START I/O instructions issued against this CUA while this volume was mounted.
6. These eleven columns contain counts from the statistical data that is recorded in the OBR records, as follows:

ENV VRC	total envelope/vertical redundancy check count
MTE LRC	total multitrack error/longitudinal redundancy check count
POST AMBL	postamble count
C/P COMP	c/p compare count
CRC III	cyclic redundancy check iii count
WRTG VRC	write trigger vertical redundancy check count
SLOW BEG	slow begin read back check count
SLOW END	slow end read back check count
CHAN BUFF	channel buffer count
ERLY BRBC	early begin read back check count
PART REC	partial record count
TIE	track in error parity bit (P) and byte (07)

3420/3803 REFERENCE GUIDE

7. **DENSITY.** From the mode byte in the OBR record.
8. **HDR SER.** The serial number of the creating drive, from the tape header.
9. Totals and averages of the data presented in the report.

TAPE VOLUME STATISTICS SUMMARY										REPORT DATE 174 82		PERIOD FROM 170 82		TO 171 82					
VOLUMES EQUAL TO OR BELOW LIMITS OR PERMANENT ERRORS										----- 3420 -----		----- 6250 -----		----- 3410 -----					
1 CURRENT LIMITS										1600 BPI		6250 BPI		1600 BPI					
KEYTES/ERR(CT)										TEMP WRT(CT)		TEMP RD(CT)		TEMP WRT(CT)		TEMP RD(CT)			
VOLUME										4 (15)		26 (2)		4 (15)		26 (2)			
2										3		4		5		6		7	
VOLUME	SERIAL	DTE	TIME	R	W	E	MB/ERR	PERM	MB/ERR	TEMP	CLNR	ERASE	SIOCOUNT	BLK	JOB	P	DEN	HDR	
			HH:MM:SS	CUA			READ(CT)	WRITE(CT)	WRITE(CT)	READ(CT)	ACTS	GAPS		LNG	NAME	U	SITY	SER	
050971	172	20:55:24	984				(0)	(0)	0(10)	3(3)	0	10	1497	29F6	EREPEX1	B	6250	05662	
050971	172	23:47:07	581				(0)	(0)	-- (0)	26(1)	0	0	2439	25F6	EREPEX1	A	6250	05662	
051007	172	23:31:31	3C2				(0)	(0)	0(1)	0(4)	0	0	37	29F6	EREPEX2	A	6250	09146	
076803	172	23:23:27	988 E				(0)	(0)	24(7)	-- (0)	0	8	12989	32C8	EREPEX25	A	6250	08965	
076803	172	23:33:38	988 E				(0)	(0)	-- (0)	-- (0)	0	0	0	25F6	7	B	6250	06350	
076803	172	23:35:24	988 E				(0)	(0)	-- (0)	-- (0)	0	0	12966	32C8	EREPEX35	A	6250	09014	
079699	172	11:29:08	3C5 R				0(1)	-- (0)	-- (0)	-- (0)	18	0	42	2000	EREPEX4	A	6250	04393	
079699	172	11:35:32	3C5				(0)	(0)	-- (0)	-- (0)	0	0	3	29F6	EREPEX4	B	6250	06335	
079699	172	11:44:45	652 R				0(1)	-- (0)	-- (0)	-- (0)	18	0	42	2600	EREPEX4B	B	6250	04420	
079699	172	11:51:51	992				(0)	(0)	-- (0)	-- (0)	0	0	3	25F6	EREPEX4B	A	6250	06635	
081628	172	12:58:18	3C4				(0)	(0)	1(25)	-- (0)	0	28	2352	29F6	EREPEX5	B	6250	07431	
COLUMN TOTALS:							(2)	(0)	(43)	(8)	36	46	32370						
TOTALS:							MOUNTS = 7												
CPU	MODEL	SERIAL NUMBER																	
A	3033	707070																	
B	3033	806080																	

Figure 4.5 Tape Volume Statistics Summary

Tape Volume Statistics Summary

This report shows all the activity for every volume listed as an exception on the Tape Subsystem Exception report. Entries are grouped by volume serial and listed in chronological order.

Notes:

- CURRENT LIMITS.** Because the report includes temporary errors, the current LIMIT values for volumes appear for comparison.
- VOLUME SERIAL.** There is no volume serial number if the tape is unlabeled or cannot be read.
- R W E.** This column contains the permanent errors recorded against this volume. An R indicates read errors, a W indicates write errors, and an E indicates equipment checks.
- MB/ERR PERM.** The error count and frequency for permanent read and write errors.
- MB/ERR TEMP.** The error count and frequency for temporary read and write errors.

3420/3803 REFERENCE GUIDE

6. Except for the CPU indicator, these columns contain information taken from the OBR record:

CLNR ACTS	cleaner action count
ERASE GAPS	erase gap count
SIOCOUNT	start I/O instruction count
BLK LNG	block length from the OBR record: or the average block length
JOB NAME	the job name
DENSITY	tape density, from the mode byte from the OBR record

7. **HDR SER.** The serial number of the creating drive.
8. Totals for the volumes on this report.

LIMIT Control Statement

The LIMIT control statement allows you to set the error thresholds, or limits, that you want EREP to use for the Subsystem Exception reports. The keyword values you specify on the LIMIT statements control the printing of temporary and soft errors: the reports include data only for devices with errors that equal or exceed any of the limits that you specify.

The format of the LIMIT statement is:

$$\text{LIMIT } \left\{ \begin{array}{l} \text{dasd}, d_1 [, d_2] \dots \\ \text{tape}, t_1 [, t_2] \dots \\ \text{cpu}, c_1 [, c_2] \dots \end{array} \right\}$$

where d, t, and c are product-dependent keyword parameters with associated numeric limits.

"tape" can be one of the following:

34XX
3410
3420

34XX is a general device type designation that includes both 3410 and 3420. When you code 34XX on a LIMIT statement, you are requesting that the limits apply to all devices of the general type.

Coding the LIMIT Statement

- o "LIMIT" must be the first character in the statement, followed by one blank and keyword parameters separated by commas.
- o There is no limit on the number of statements you may code. However, only one 34XX statement is allowed.
- o If you code a second LIMIT statement for one specific device type, its values override those set in the first statement. EREP uses the limits set in the latest LIMIT statement.
- o The limits you specify on the LIMIT statements apply only to temporary errors for tape.

The keyword parameters for the LIMIT statement, and some aspects of the limiting action, differ depending on whether you are coding for DASD, tape, or processor/channel. Therefore, the tape group is described separately on the following pages.

Using the LIMIT Statement for Tape (34XX)

The limiting action works differently for tape devices than it does for DASD. You need two sets of keyword parameters for each device type, and you must specify which tape density the limits apply to.

The valid keywords for tape drives are:

To Set Limits For:	Use Keyword:
1600 BPI Temporary Errors	
Hardware read	HR1600=nnn(ct)
Hardware write	HW1600=nnn(ct)
Volume read	VR1600=nnn(ct)
Volume write	VW1600=nnn(ct)

6250 BPI Temporary Errors

Hardware read	HR6250=nnn(ct)
Hardware write	HW6250=nnn(ct)
Volume read	VR6250=nnn(ct)
Volume write	VW6250=nnn(ct)

where:

nnn

is a 3-digit decimal value representing the number of megabytes of data processed between errors (MBYTES/ERROR).

(ct)

is a decimal value from 1 to 99 representing the number of errors encountered before the device or volume appears on the Subsystem Exception report.

EREP uses both these values to establish thresholds for temporary errors. If the number of errors recorded against the device or volume is greater than the count (ct) value, AND the average number of megabytes of data processed between errors is less than the error frequency (nnn) value, then the device or volume will appear on the Tape Subsystem Exception report.

Notes:

1. If you do not code LIMIT statements for a tape device or volume, the Tape Subsystem Exception report includes only the permanent errors recorded against that device or volume. However, all temporary errors appear in the Tape Temporary Error Summary.

3420/3803 REFERENCE GUIDE

2. You should specify all LIMIT values. Results are unpredictable if any values are omitted, or if a value is coded as a 0.
3. 34XX includes only 3410 and 3420 tape drives.
4. The density of 6250 BPI applies only to 3420 drives. If coded on LIMIT statements for 34XX, it is ignored for 3410 devices.
5. If a tape drive is operating at a density other than 1600 or 6250 BPI, EREP uses the LIMIT values you specify for 1600 BPI.
6. Only one LIMIT statement for 34XX is allowed.
7. You cannot continue a LIMIT statement from one line to the next. Generally, you should use separate LIMIT statements to establish hardware and volume limits for a device. If the device operates at both 1600 and 6250 BPI, you must use separate statements. However, if only one tape density is involved, you can combine all four keywords on the same LIMIT statement. For example, you might want to see only some of the temporary errors for your 3410 and 3420 drives, operating at 1600 BPI density, as follows:

Hardware

Read - 1 or more errors, at 25 megabytes/error
Write - 15 or more errors, at 10 megabytes/error

Volume

Read - 1 or more errors, at 25 megabytes/error
Write - 15 or more errors, at 10 megabytes/error

To set these limits, you could code the following LIMIT statements:

```
LIMIT 3410,HR1600=025(1),HW1600=010(15),VR1600=025(1),VW1600=010(15)  
LIMIT 3420,HR1600=025(1),HW1600=010(15),VR1600=025(1),VW1600=010(15)
```

Since the limit values and density are the same, these two statements could be combined into a single 34XX LIMIT statement:

```
LIMIT 34XX,HR1600=025(1),HW1600=010(15),VR1600=025(1),VW1600=010(15)
```



READ/WRITE SERVICE TECHNIQUES

Temporary/Permanent Errors

The primary cause of write data checks is the type caused by a loss in signal from the tape on readback during write. On the 3420 tape subsystem when tape is written, the amplitude is checked to ensure there is sufficient amplitude written on tape to be read at a later date. This write checking level (threshold) is higher than the threshold at which the tapes will eventually be read. If the amplitude of the read signal goes below the threshold, a temporary write error occurs and the error recovery program (ERP) takes control. ERP does a back space record (BSR), then performs an erase gap before retrying the write operation. If the write is then error-free, one temporary write error is logged and normal operation continues. If the retried write operation again fails another erase gap, then write is performed. This is continued until the write is successful or until fourteen tries to write the record have occurred. In that event one loop write-to-read command is tried. If successful, one more erase gap, write is attempted. If it again fails (fifteenth time), a permanent write error is posted.

If the write command is successful on retry number 10, EREP would show nine erase gaps (actual number) but only one temporary write error. The reason for this is that write errors occurring while ERP has control are not logged to EREP while all erase gaps are.

Several causes of data check on tapes are:

1. Defects in oxide on tape.
2. Dirty tape
3. Dirty tape path
4. Edge damage on tape
5. Contamination on head
6. Tape drive failures (ex. pneumatics, capstan, R/W circuitry)

When excessive errors are encountered on a tape, corrective action should be taken. The first action would be to inspect the tape path for contamination. If any foreign material is present, it should be removed by using normal cleaning procedures. If error persists, the tape should be tried on a second tape device (if available) or a different, known good, tape should be put on the failing tape unit. In this way, the error condition can be isolated to the tape or to the tape unit. When a tape with large numbers of errors is found in a customer library, it should be identified and corrective action by customer should be taken. This can include cleaning and recertification of the tape or removing the tape from the tape library. If a tape shows signs of damage or contamination, it should be removed before it can cause damage to, or cause contamination to, other tape in the customer's library.

READ/WRITE SERVICE TECHNIQUES (CONT'D)

There are many other types of errors and causes of errors. The several covered in the above text are the most common causes and are the majority of the types of errors the CE will encounter in the field.

Sense bytes that indicate read/write data flow problems are shown in the following chart:

Description	Byte	Bit	Description	Byte	Bit
WTM Check	5	2	VRC/ENV Check	3	4
IBG Detected	8	0	Write Current Fail	6	1
SAGC Check	8	4	Erase Head Fail	7	5
R/W VRC	3	0	Early Begin Read Back Check	8	3
MTE/LRC	3	1	Slow End Read Back Check	8	6
Skew	3	2	ID Burst Check	5	3
End Data Check/CRC	3	3	No Block Detected on Write WTM	10	3

All symptoms should first be analyzed using the MLM or MLM/PF.

If you are experiencing intermittent 3420 failures relating to read/write data flow, consider performing the following performance enhancement checks and adjustments in the sequence listed. (Refer to 3420 Performance Enhancement Guide - Section 7).

- A. Initial checks
- B. Read/Write

Other items to be considered are:

SIGNAL STABILITY - Scope the analog signals on each track, the amplitudes should be constant and about equal between tracks.

READ/WRITE SERVICE TECHNIQUES (CONT'D)

BIT POSITIONING - The two outside tracks, tracks 4 and 5 in PE, should be equidistant* from their respective edges. Improper bit positioning can be caused by capstan tracking and/or improper skew plate alignment. Failures can appear as system abends and tape mark recognition problems. Replacing the R/W head will appear to fix the problem for a very short time.

The following procedure can be used to verify correct skew plate alignment with respect to bit positioning. If frequent R/W head replacement is necessary, perform skew plate alignment procedure to insure proper tape to head (wrap) angle.

1. Verify that all tracking adjustments are correct.
2. Load a good tape on the drive.
3. Using the 3420 tester, set up to write all ones continuous.
4. Write 2 to 3 feet of tape from load point.
5. Remove and develop tape.
6. Using high-intensity light and magnifying glass (P/N 451513), look at the two outside tracks compared with the edge of the tape. They should be equidistant from the tape edges. If they are not equidistant, skew plate adjustment is necessary. Refer to 3420 service aids 9 and 10 for necessary tools and parts to perform skew plate adjustment.

*Note: The engineering specification for track spacing measures the distance from the front edge to the center of the "5"-track. (See Figure 1). This distance is $.029 + .003$. If the media width and the head tracks are within tolerance, then the outside tracks will appear equidistant.

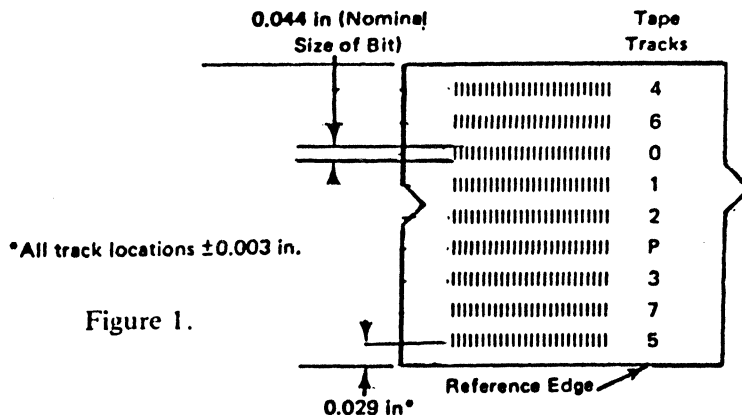

Figure 1.

PHASE ERRORS - Phase errors are indicated by MTE errors without envelope checks. Scoping is done in the 3803 while writing ripple data with a block length of 2K or larger. This procedure is for model 4,6, or 8 only. Refer to the phase shift scoping procedure in this section for complete details.

CAPSTAN TRACKING CHECK - Using the master skew tape, scope the 4 and 5 tracks. The signals should be equal and opposite between forward and backward. For example, if track 4 leads track 5 by one usec in the forward direction, track 4 should lag track 5 in the backward direction by the same amount. Note: This is a check. Do not use for adjustment. (See MLM 08-150, 08-151, 08-160).

READ/WRITE SERVICE TECHNIQUES (CONT'D)

FRU REPLACEMENT/SWAPPING

The following FRUs are listed in the recommended replacement or swapping sequence. If a part does not fix the drives symptom, return the swapped part to the original drive.

1. MST Logic Cards (See Read/Write Data Flow Page 5.13, 5.14)
2. Read Head Card
3. Write Head Card - (On Mod 4,6,8 check to ensure that the write card jumpering is correct).
4. Read/Write Head - When a new head is installed for diagnostic purposes, only the AMP sensors need to be adjusted. If the head resolves the problem, make certain the Read/Write Adjustment procedures in the MLM (see 08-250) are followed.

3420 READ/WRITE SERVICE TECHNIQUES

PHASE SHIFT

Definition - A pulse time displacement that occurs at the transition from a low density recorded signal to a higher density, or from a high density signal to a lower density.

When recording at higher densities, several problems are encountered. As density increases, the preceding and following bits (flux fields) tend to interfere with the middle bit (see Figure 1). This phenomenon is known as phase shift. The resultant data transition at a change in recording density is shifted to the right or left because of the bit crowding effect. This characteristic of PE recording is compensated for by detection techniques.

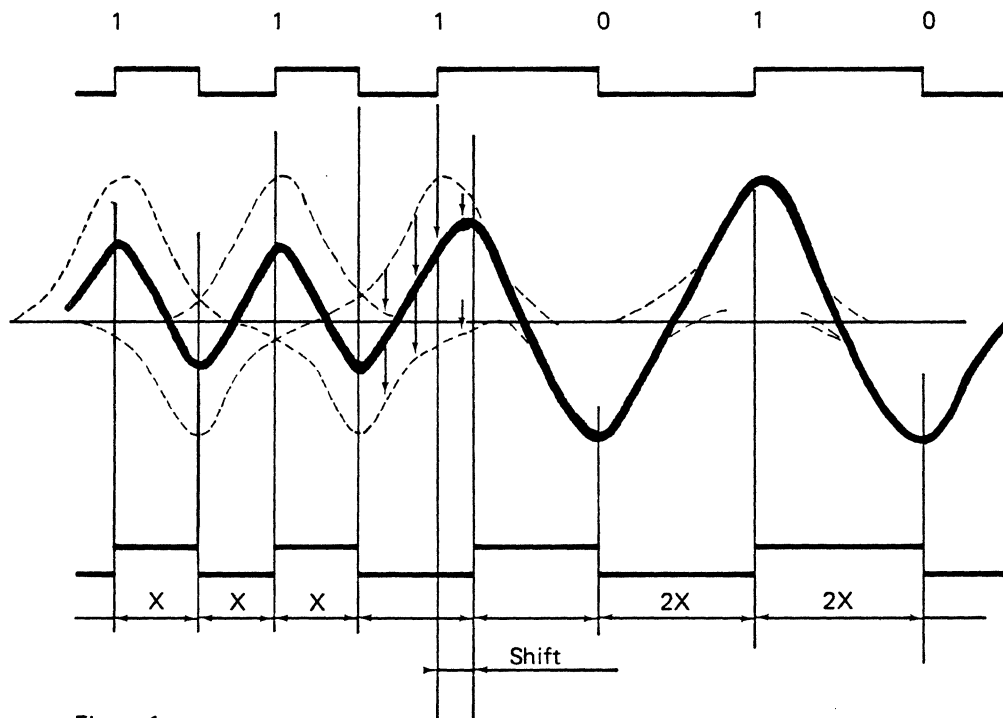

Figure 1

READ/WRITE SERVICE TECHNIQUES (CONT'D)

PHASE SHIFT SCOPING PROCEDURE

If you are having a high number of temporary write errors with MTE and not ENV errors, use the following procedure to determine if the R/W head is causing phase shifting problems.

Using a good customer tape:

1. Check the SAGC setup. Refer to the 3420 Performance Enhancement Guide - Section 7. The SAGC should set up in 0 to 14 steps.
2. Loop write reliability test 3420R in 6250 mode.

Scope the phase pointers:

<u>Logic</u>	<u>Card</u>	<u>Pins</u>	
CD191	Y1M2	G12, J11, J12	Zone 1
CD291	Y1L2	G12, J11, J12	Zone 2
CE391	Y1K2	G12, J11, J12	Zone 3

Sync Points: Crosspoint cards can be used so that only data from the drive you are running OLTs on is displayed (ie, logic XC701 drive 0 A3Q2D12). Refer to Chart L for your machine configuration. If you have the entire subsystem, sync point (mark 1) logic BW151 A1G3M12 may be used.

If a phase pointer continually goes active, in the data area, the head may be marginal. Occasional phase pointer may occur because of envelope fallout. This procedure is intended to find new heads that may be marginal but should be used as a check for existing heads. Refer to MLM 08-250 for additional information.

COMPATIBILITY PROBLEMS

Compatibility problems between drives can be caused by capstan tracking out of adjustment. If this adjustment is OK, then bit positioning may be the cause of the incompatibility. Refer to page 5.3 for bit positioning and capstan tracking checks.

READ/WRITE SERVICE TECHNIQUES (CONT'D)

NOISE OR BITS IN THE INTERBLOCK GAP

To detect interblock gap errors, sync scope on - Go Forward. Read forward and backward over the failing record. Display the record in both directions and look for noise in the gap (see diagrams on MLM 5A-115 and 5B-025). Developing the tape with noise in the interblock gap shows bits written in the area between two records (sometimes faintly recorded).

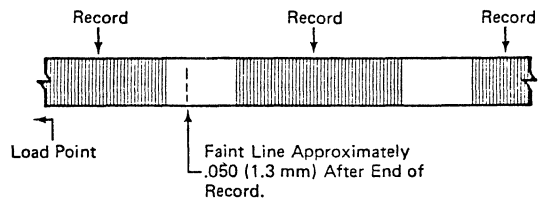

Possible Causes:

- a. Gussed or magnetized read/write head.
- b. Erase head not working.

READ/WRITE SERVICE TECHNIQUES (CONT'D)

FACTORS THAT MAY INDICATE A FAILING HEAD:

1. Media
2. System aborts indicating read or write failures
 - Tape runs off end of reel searching for a tape mark
 - No block detected on a write or write tape mark
3. High temporary write errors
4. High forward to backward analog signal ratio
5. Many OLT failures on test T3420F and very few errors on other tests
6. Varying analog signals
7. Making two amp sensor adjustments of .5 volts or greater in a short period of time

FACTORS THAT MAY INDICATE A FAILING HEAD WHEN THE HEAD IS NOT FAILING:

1. Low vacuum
2. Tape hitting obstructions in the tape path
 - Erase head
 - Filler block
 - Rewind plunger (3,5,7)
 - Auto cleaner (4,6,8)
3. Defective read or write head cards
4. Voltages out of adjustment
5. Poor capstan tracking causing tape to buckle
6. Marginal media
7. Visual wear and poor forward to backward ratio
 - Replace only if failures are occurring
8. Improper skew plate alignment

FACTORS THAT OPTIMIZE HEAD LIFE:

1. Good tape library maintenance
2. Proper and timely drive cleaning
3. Documenting problems
4. Good capstan tracking

3420 READ/WRITE NTF CHECKLIST

If you have an intermittent read or write problem and can find nothing wrong with the machine, perform the tests/checks indicated below before writing a "No Trouble Found" IR. When completing an NTF IR, try to give information as accurately as possible. Use Major Unit Code 960 instead of 980 whenever possible and include as much detail as necessary in the narrative. Your IRs are the performance feedback mechanism we use on the 3420/3803!

3420/3803 REFERENCE GUIDE

3420 READ/WRITE NTF CHECKLIST (CONT'D)

Read/Write Problems

Models 3,5,7

Most probable causes:

1. Read head card defective
2. Write head card defective
3. T-A1L2, T-A1J2, T-A1M2 (NRZI) defective
4. R/W head defective
5. Erase head defective

Initial checks:

1. Air pressure and vacuum (see 08-400)
2. -4Vdc and +6Vdc supply in tolerance (see 08-570)
3. BOT/EOT Adj (see 08-580)
4. R/W head and cleaner blade must be clean
5. Capstan tachometer timing (see 08-130)
6. Degauss tape transport if problem is recurring
7. Forward to backward ratio

Reference MLM 5A-000

Models 4,6,8

Most probable causes:

1. Read head card defective
2. Write head card defective
3. T-A1L2, T-A1J2, T-A1H2 cards defective
4. R/W head defective
5. Erase head defective

Initial Checks:

1. Air pressure and vacuum (see 08-400)
2. -4Vdc and +6 Vdc power supplies in tolerance (see 08-570)
3. BOT/EOT Adj. (see 08-500)
4. R/W head and cleaner blade must be clean (see Note 4 on 5B-001)
5. Capstan tachometer timing (see 08-120)
6. Degauss tape transport if problem is recurring
7. Forward to backward ratio (see page 7)
8. SAGC set-up (see page 7)

Reference MLM 5B-000

READ/WRITE SERVICE TECHNIQUES (CONT'D)

TAPE DEVELOPING PROCEDURE

Purpose: Gives CE a way of visually examining information recorded on a section of magnetic tape.

CAUTION: Any foreign material left on the tape will damage the drives themselves.

Tape developing procedures are found on MLM page 00-011 for a 3803-2 and on MLM page 00-014 for a 3803-1.

Conclusions: Some of the more common problems which will be detected by tape developing are:

- a. Partially erased records before an ERG (erase gap). Usually caused by a glazed capstan.
- b. Noise in gap (defective erase head, etc.)
- c. Short gaps (indication of tape motion problem).
- d. Damaged tape (oxide voids, etc.)

See the following examples.

DEVELOPED TAPE EXAMPLES

Here are some tips which may be helpful in analyzing the failure on a developed tape:

- o Distance Relationships:

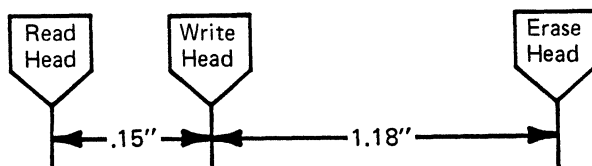

DEVELOPED TAPE EXAMPLES (CONT'D)

o Erase Gap (ERG) Distances:

Density	Single ERG	Successive ERGs
6250	3.75"	3.45"
1600	4.2"	3.6"
800	4.2"	3.6"
7-track	4.5"	3.75"

o Interblock Gap Size:

Density	Nominal (Inches)	Minimum (Inches)
6250	.3	--
1600	.6	.5
800	.6	.5
7-track	.75	.68

o Developed Tape Examples

Good Data at 1600 bpi

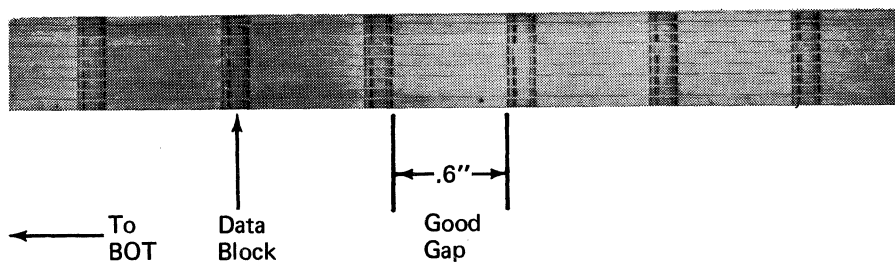

3420/3803 REFERENCE GUIDE

DEVELOPED TAPE EXAMPLES CONT'D.

The following illustration shows a good 6250 bpi tape label area from BOT to the first customer records.

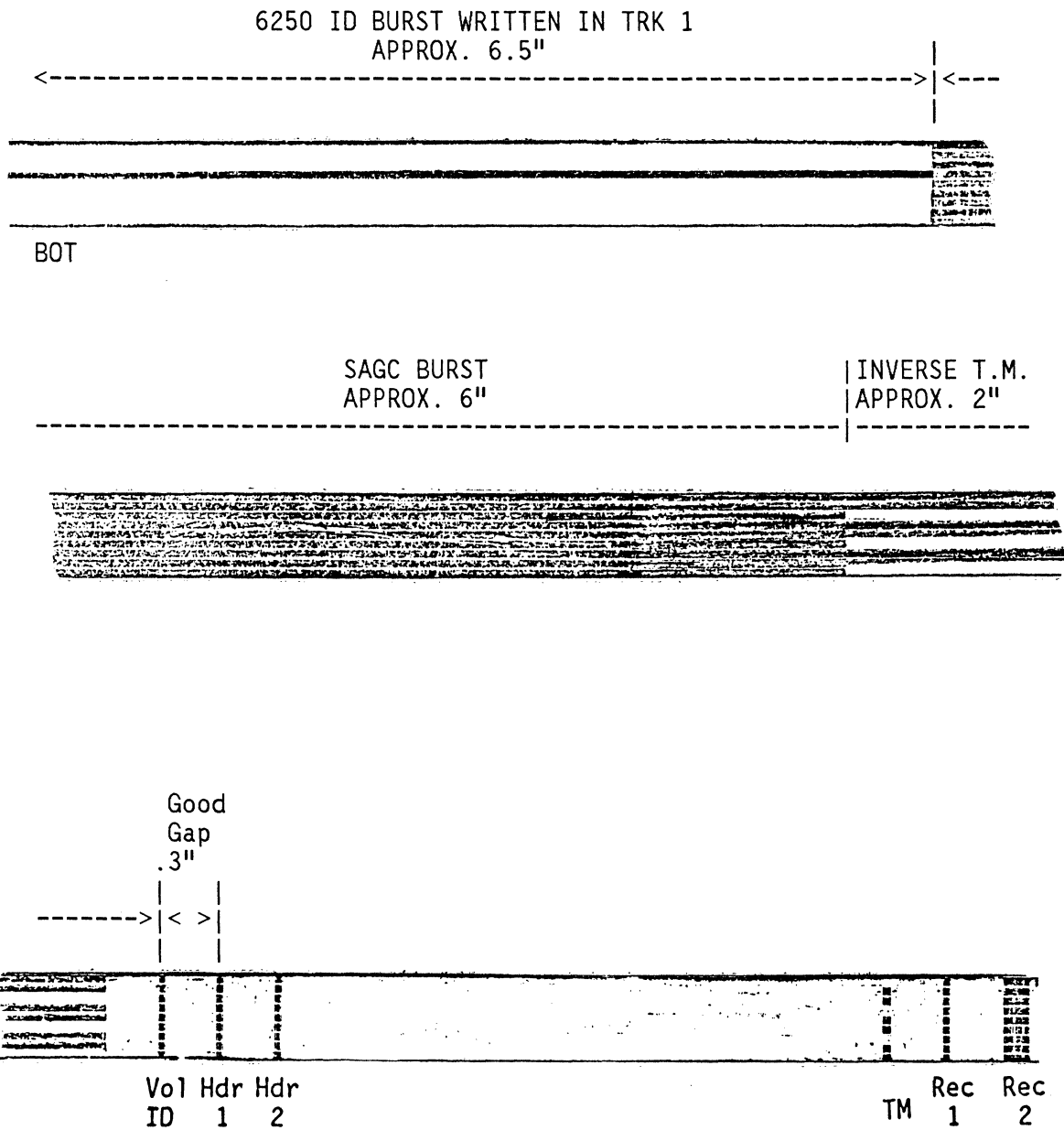

DEVELOPED TAPE EXAMPLES (CONT'D).

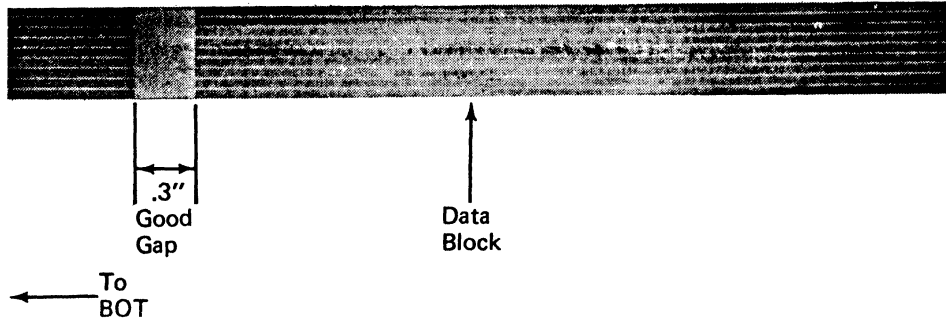

Tape cinch/tape crease (1600 bpi)
caused by loose wraps on tape reel.

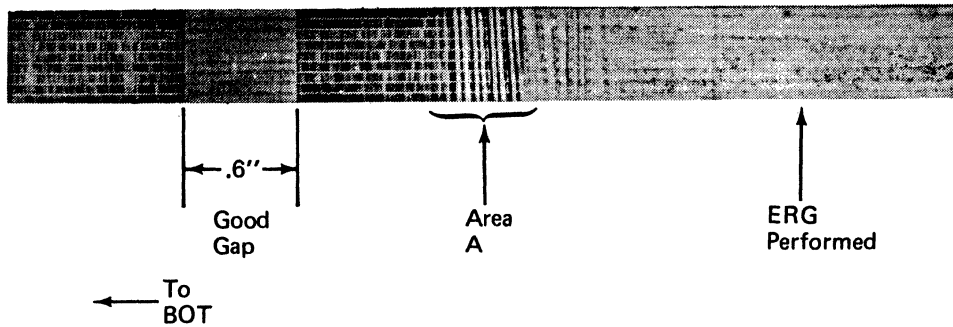

- o Drive was writing when "cinched" tape (small Z-folds) area appeared (area A).
- o Prior to performing an erase gap, the software tried to back tape up to last interblock gap but stopped in the creased area instead (thought it was the gap).
- o From there a normal ERG command was executed and tape unit logged one temporary write error and continued normally.
- o Since damaged area was not completely erased by erase gap, a permanent read error then occurred when tape was read.

3420 RD/WR DATA FLOW

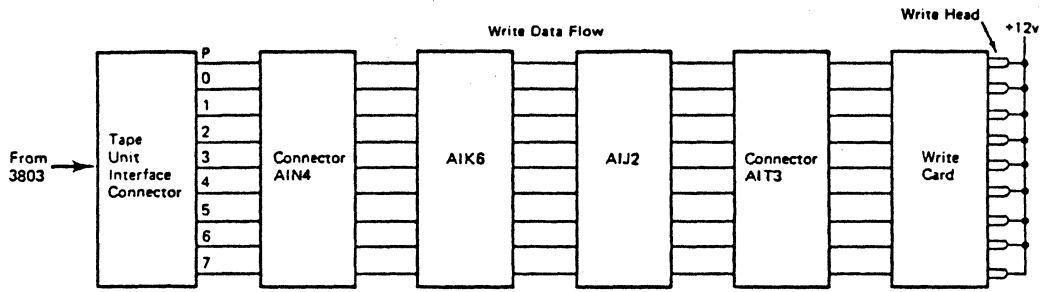

Read and Write Data Flow
Within 3420
— Models 4, 6, 8 Only —
(See MLM 5B-100 For Details)

R/W Head Pin Layout
(Models 4, 6, 8 Only)

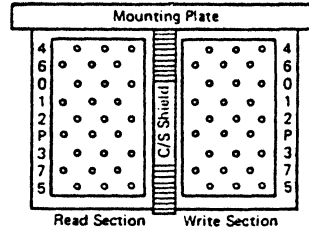

Note: The center tap
is the middle pin
on each track.

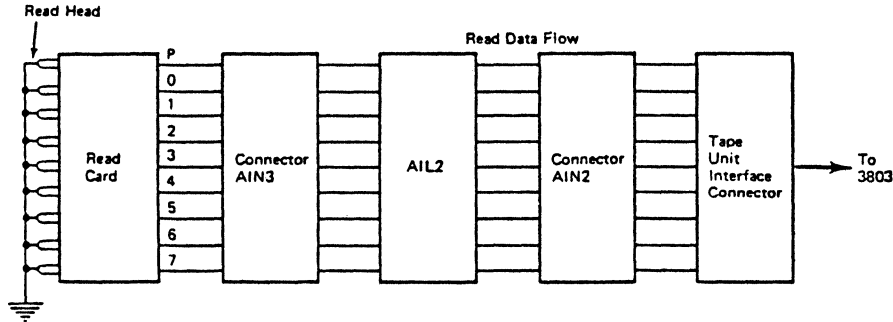

3420 RD/WR DATA FLOW (continued)

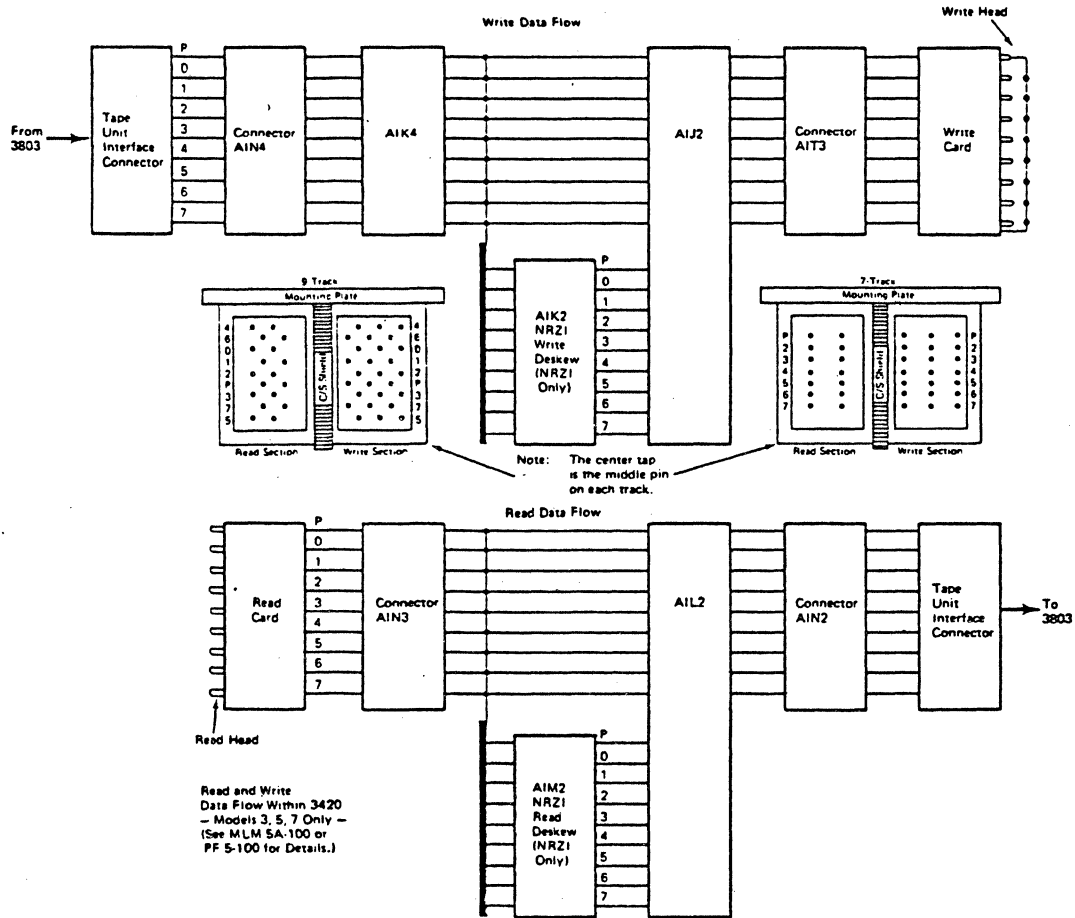



3420 TAPE MOTION SERVICE TECHNIQUES

Sense bytes that indicate tape motion problems are shown in the following charts:

Description	Byte	Bit
Early Begin Read Back Check	8	3
Dynamic Reversal Error	10	4
Velocity Check	10	7
Velocity Change During Write	9	1
Tach Start Failure	10	5
Start Rd Check	5	4
Partial Record	5	5

All symptoms should first be analyzed using the MLM/Pathfinder.

If you are experiencing intermittent 3420 failures relating to tape motion, consider performing the following performance enhancement check and adjustments in the sequence listed. (Refer to 3420 Performance Enhancement Guide - Section 7)

- A. Initial Checks
- B. Pneumatic System
- C. Capstan

3420 TAPE MOTION SERVICE TECHNIQUES (CONT'D).

Some of the more common symptoms associated with tape motion are:

1. Short gaps
2. Partially erased records
3. Permanent R/W errors
4. High number of temporary R/W errors
5. Dropping ready
6. No tape motion
7. Dumping tape

Possible causes for tape motion symptoms are:

1. Glazed/dirty capstan
2. Leaky transfer valve
3. Vacuum switches
4. Vacuum column door adjustment
5. Loose/misadjusted stubby bars
6. Open capstan motor segment

GLAZED CAPSTAN CLEANING

This procedure is performed only if glaze cannot be removed by normal cleaning.

CAUTION: This procedure, if not done properly and with extreme care, can shorten the life of (or damage) the capstan. If the capstan edges are rounded or flat spots are created, tracking adjustments will not be possible.

To verify that this procedure is necessary:

1. Perform Capstan Cleaning-Normal Procedure (see 85-004 if necessary).
2. Perform T3420W OLT diagnostic test.
 - o Run OLT T3420W to determine the size of interblock gaps. (0.301 inches is nominal for 6250 bpi and 0.600 inches is nominal for models 1600 bpi).
3. Check diagnostic printouts for signs of variance.
 - o Gap sizes exceed limits specified in OLT.

If the tape is varying, the glazed capstan cleaning procedure may be necessary. (Refer to MLM 08-700)

Vacuum column door adjustment (Refer to Section 7)

3420/3803 REFERENCE GUIDE

3420/3803 REFERENCE GUIDE

CAPSTAN MOTOR TEST

Unplug the capstan motor from the capstan board and measure across the two wires going to the motor with an ohmmeter. Rotate the capstan slowly by hand while watching ohmmeter. The meter will deflect some but should never go to an open condition (open armature segment). If an open condition occurs, the capstan motor should be replaced.

3420 TAPE MOTION SERVICE TECHNIQUES (CONT'D).

NOTE: In the pneumatics portion of the drive verify normal pressure and vacuum adjustments and checks per MLM 08-400 before performing the following tests.

COLUMN VACUUM LEAKAGE TEST

If you suspect a column vacuum leak, the following procedure is a good way to check column vacuum level:

- Take drive offline and install tape motion tester.
- With drive unloaded, disconnect tubing to L3 or R3 vacuum switch.
- Use a "Tee" (P/N 1767025) to insert vacuum gauge (P/N 5495384) in the line.
- Reconnect tubing to L3 or R3 then load tape and read gauge. Vacuum level should be:

Vacuum Chart for All Models Without EC 847202

Vacuum Chart for All Models With EC 847202

Model	Column Vacuum Level	Model	Column Vacuum Level
3,4,5,6	21±3"	3,4,5,6,7	+3" 30-2"
7	27±3"	8	36±1"
8	31±2"		

- Move tape forward and verify that vacuum level remains within tolerance.
- Move tape backward and verify vacuum level.
- If vacuum levels read low on these tests, clean column-to-glass mating surfaces and check column glass adjustment.

CRACKED PRESSURE HOSES

When analyzing any problem relating to pneumatics, check for cracked pressure hoses. The hose between pump and filter should be closely examined. If a hose is found to be cracked, replace it. Check decal; if pressure tubing change is required, install pressure tubing B/M. Do not cut the hose back because it will soon crack again.

3420 TAPE MOTION SERVICE TECHNIQUES (CONT'D)

TRANSFER VALVE LEAKAGE TEST

1. Open column vacuum door. Cover the stubby column ports with masking tape. See Figure 1. Do not let the tape overlap the stubby bars.
2. Place an 8-inch piece of magnetic tape in the bottom of the right vacuum column to prevent vacuum from entering the column.
3. Cut a 12-inch piece of magnetic tape and lay it over the left reel tach just below the read/write head. Ensure that the tape loop is approximately in line with the bottom of the capstan. See Figure 1. Close vacuum column door. Bypass the door interlock.
4. With no tape on the right reel, press LOAD REWIND. If the tape strip is pulled into the left column before load check occurs, there is sufficient leakage to cause intermittent problems and the transfer valve must be replaced. Repeat the test several times to ensure that the valve is bad.
5. Remove the masking tape from the stubby column ports and clean the the area thoroughly with a cloth dampened with tape cleaner. Remove the magnetic tape from the right and left vacuum columns.

Figure 1.

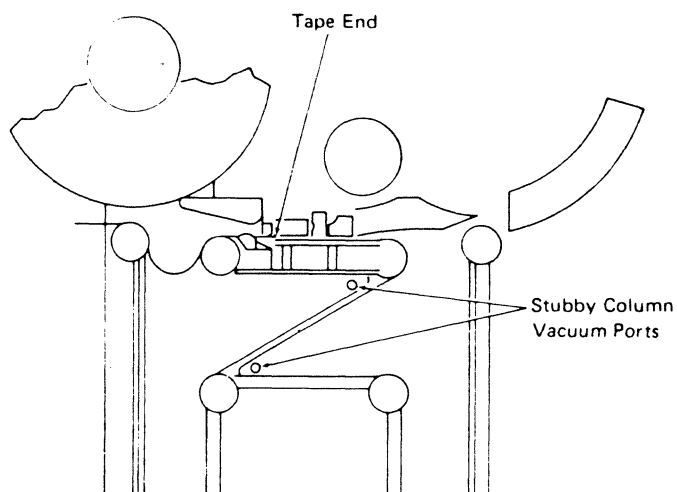

3420 TAPE MOTION SERVICE TECHNIQUES (CONT'D)

TAPE SLIPPING

Tape slip usually occurs during dynamic reversal while performing an erase gap command. Tape slip causes the tape to be incorrectly positioned. When the write head becomes active, it then erases part of the previous record. (The record before the error record that the erase gap command was supposed to erase).

Developing the tape shows the postamble missing on the previous record. For details see Tape Developing Procedure in 3420/3803 Reference Guide.

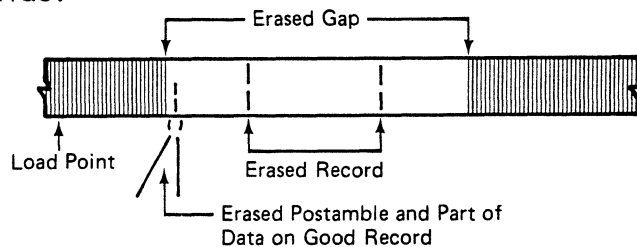

Possible Causes of Tape Slip:

- a. Loss of capstan vacuum on Model 8.
- b. Drag in the tape path.
- c. Dirty air bearings.
- d. Low air pressure.
- e. High or low vacuum.
- f. Door glass leakage.
- g. Damaged capstan surface.
- h. Possible media problem.

BIT PACKING

Bit packing is due to varying capstan speed or tape slipping. For scoping procedure see MLM 5A-115 or 5B-025. Also see 3420.

Possible Causes of Bit Packing:

- a. Tape slip when written (glazed capstan).
- b. Dented capstan.
- c. Vacuum and air pressure out of specification.
- d. Plugged air bearing.
- e. Improper operation of digital to analog converter (DAC).
- f. Defective capstan control board.
- g. Binds in capstan motor.

3420/3803 REFERENCE GUIDE

3420 TAPE MOTION NTF CHECKLIST

Perform these checks precisely as described in MLM.

Check, adjust if necessary:

- | |
|--|
| <ul style="list-style-type: none">o BOT/EOT (08-580)o Capstan Tachometer Adjustment (08-120 or 08-130)o Pneumatics (08-400 (all) and 08-420) |
|--|

Reference MLM START 1.

3420 TAPE MOTION SERVICE TECHNIQUES (continued)

6. If 3420 Drops Ready:

Analyze Sense or Scope Error Latches to Find Reason					
Error Description	Drive Error Latches (See Note)	Error Sense	Probable FRUs	Further Analysis	Notes
Fiber Optic Lamp Failure	+ At S07 (Note Latched)	Byte 7 Bit 0	<ul style="list-style-type: none"> • Optic Lamp • A1D2 	See Logic FT114	
Tape Bottom or Pull Out of Left Column*	+ At U02	Byte 7 Bit 1	<ul style="list-style-type: none"> • L4 Vac Switch • L3 Vac Switch • Left Reel Board • Capstan Tach 	Go To 3A-110 or 3B-110	Could Be Caused By OV/UV Detection or Capstan Board Cooling Sensor. See Byte 18 Bit 0 Below.
Tape Bottom or Pull Out of Right Column	+ At U05	Byte 7 Bit 2	<ul style="list-style-type: none"> • R4 Vac Switch • Right Reel Board • Capstan Tach 		
Reset Button or Door Interlock	+ At S03	Byte 7 Bit 3	<ul style="list-style-type: none"> • Reset Button • Door Inlk Switch • TA1C2 • AB3F2 • AA2D2 	See Logic FT114	Could Be Caused By Operator.
Air Bearing Pressure or Right Reel Hub Failure	+ At S04	Byte 7 Bit 6	<ul style="list-style-type: none"> • Leaking File Hub • Air Bearing or Hub Switch 		If A Solid Failure Tape Will Not Dump Into Cols on Load.
OV/UV (Power Check) or No Cooling Air to Capstan Board	- At S02	Byte 18 Bit 0	<ul style="list-style-type: none"> • Check Voltages • Dirty Filter • Defective Cooling Fan • Check Cooling Air Sensor 	Go To 1A-000 or 1B-000	These Errors Cause Reel Board EPO Relays to Drop (Loss of Motor Control). Tape Bottom Will Then Drop Ready
Power-On Reset	+ At M05 (Not Latched)		<ul style="list-style-type: none"> • A1C2 • A1H2 • Fuse Detect Card 	See Logic FT112	These Are Not Normal Drop Ready Conditions. However, Intermittent Failure May Show as a Drop Ready.
Safety Bail Reset	Models 3,5,7 + At E2B09 (Not Latched) Models 4,6,8 + At D4B09 (Not Latched)		Models 3,5,7 <ul style="list-style-type: none"> • A1C2 • A1E2 Models 4,6,8 <ul style="list-style-type: none"> • A1K2 • A1D4 	See Logic FT283	

NOTE

- Drive error latches are on following card:
Mod 3, 5, 7 - H2
Mod 4, 6, 8 - M2
- Voltage Levels are:
+ is - .85
- is - 1.85

*Vacuum switches are high-failure items.

Column Vacuum Switch Scope Points			
Ground = Tape Above Switch -4vdc = Tape Below Switch			
L1	B2S02	R1	B2S08
L2	B2S03	R2	B2U09
L3	B2U04	R3	B2S09
L4	C2P09	R4	C2M09

Pressure Sensing Switch Scope Points		
Ground = Pressure Good -4vdc = Pressure Bad		
Air Bearing Pressure	Model ↓	Reel Latch Pressure
E2M03	3, 5, 7	E2J02
D4M03	4, 6, 8	D4J02

3420/3803 REFERENCE GUIDE

3420 PERFORMANCE ENHANCEMENT GUIDE

Performance Degradation

A. General

1. Degraded performance of the 3420 can occur for a wide variety of reasons.
2. Some degradation is caused by factors outside the primary area of CE responsibility (bad media, dirty tape drive, poor handling, or other operational procedures).
3. Pneumatics, capstan, R/W circuits and tape path elements within the area of CE action.
 - a. Pneumatics - low column vacuum, low pressure to or poor air flow through air bearings, incorrect door sealing resulting in poor tapered column operation, or tape dragging.
 - b. Capstan - slight binds, glazed surface, poor adjustment (dynamic tracking).
 - c. R/W circuits - marginal or defective read or write cards, marginal or defective read/write head (weak or excessive signals, bad forward/backward signal ratio).
 - d. Tape path - improperly operating or adjusted auto cleaner, ineffective cleaner block.

3420 PERFORMANCE ENHANCEMENT (CONT'D)

This guide will provide checks and adjustments which when completed should improve the drive performance. They basically serve as a maintenance procedure for drives that fail to meet performance objectives. Using EREP data as a basis for measuring drive performance, if a decrease in performance is observed after a few days of operation, this may indicate a marginal or a "new defective" component. If so, these procedures must be repeated to find the marginal/defective parts.

The following hardware procedures should be performed in the sequence listed and all notes observed.

- | | | |
|---|------------------|----------------|
| A. Initial Checks | MLM | |
| Air Filter | 85-005 | |
| DC Voltages | 08-570 | |
| B. Pneumatic System | | |
| Column Vacuum | 08-400 | |
| Threading Vacuum | 08-400 | |
| Transfer Valve Leakage | 08-400 | |
| Regulator Pressure | 08-405 | |
| Vacuum Door Adjustment | 08-680, 690 | Page 7.4 |
| C. Capstan | | |
| Capstan Cleaning | 85-004 | |
| Dynamic Alignment
(tracking) | 08-150, 151, 160 | |
| Squaring
(ensure state lengths are correct) | 08-120, 130 | |
| D. Read/Write | | |
| Mechanical Skew | 08-170 | |
| * Read Amp Sensors-PE Only
(Model 3,5,7) | 08-290 | |
| * Read Amp Sensors-NRZI
Feature
(Model 3,5,7) | 08-300 | |
| Read Amplitude
(Model 4,6,8) | 08-310 | Page 7.7 |
| Forward/Backward Ratio | 08-240 | Page 7.9, 7.11 |
| SAGC Checks | 08-315 | Page 7.12 |

* Use Procedure in MLM

CHECKS AND ADJUSTMENTS

A. Initial Checks

1. Check that air filter is clean and blower is running smoothly.
2. Check/adjust DC voltages (watch for excessive ripple). MLM 08-570.
3. Preliminary visual check of entire tape path (use check list - see 7.11 of this section); look for objects stuck to air bearings, cleaner block, erase head, left threading ramp, filler block or rewind plunger.
4. Clean head and check auto cleaner ribbon. The ribbon should just touch the R/W head and should not have a dark spot on it (which indicates failure to move). MLM 08-360 through 08-362.
5. Check that read and write cards are properly seated on the head.
6. Check capstan for binds or missing rubber and if it is glazed, use deglazing procedure. MLM 08-700.

B. Pneumatics

Out of spec. pneumatics sometimes show first as very intermittent read/write errors. If allowed to continue, the more obvious result is load/unload or drop ready indications.

1. Vacuum (MLM 08-400)
 - a. Column vacuum has a negative effect on read/write performance if below specifications. Transfer valve leakage test is only a general indication. It must be repeated several times to verify any possible failure.
2. Pressure (MLM 08-405)
 - a. Threading pressure is significant for proper load operation and is indicative of overall drive pressure system operation.
 - b. Pressure gauge should be observed during the entire load operation. A significant drop during load could be indicative of either a leak or clogged input filters.
 - c. A good pressure reading at the test point when load is complete is important. Another factor equally important is sufficient air flow through the air bearings.

CHECKS AND ADJUSTMENTS (CONT'D)

- (1) Openings in air bearings should be cleaned out yearly.
 - (2) Air exhaust from the pressure regulator should be present at the opening just under the cone top of the regulator.
3. Vacuum column door (08-680, 690)
- a. Door frame vertically adjusted to produce correct float plate to threading channel relationship. Refer to MLM 08-680 for details.
 - b. Glass adjustment vertically within frame so that upper edge of glass partly covers lower stubby bar but does not come in contact with capstan or "D" bearing. For Model 6 & 8 3420s, a quick test is to grasp the resonator and lift up, only a slight movement should be present. Glass maladjustment can cause improper tapered column operation, resulting in errors such as R/W errors, start read checks, etc.
 - c. Foam strips around glass should have resiliency to keep glass snug within frame. Slight lateral movement in the glass should be present to ensure no bind between the glass and the door frame.
 - d. Hinges and/or latches should cause door frame to close very snugly.

CHECKS AND ADJUSTMENTS (CONT'D)

3A. Vacuum column door adjustment

The total amount of lateral clearance between the door glass and the side clamps is .003 to .005.

Loosen the non-hinge side clamps.

Insert a .005" feeler gauge between the edge of the door glass and the non-hinge side clamps.

Insure the edge of the door glass is in contact with the hinge side clamps. Position the non-hinge side clamps against the feeler gauge and tighten the non-hinge side clamp screws.

Remove the feeler gauge.

Note: Check to insure free vertical movement of the door glass.

In the following steps, access to the shim package should be obtained by removing the hinge side clamps. These clamps must be reinstalled after each shim package modification. This insures prior door glass adjustments are maintained.

Install the capstan protective cleaning cover.

While viewing from the left of the machine, slowly start to close the vacuum column door observing the top of the door glass to right side of the capstan cover relationship.

The top of the door glass must interfere with the right side of the capstan cover in order to continue this procedure. If the top of the door glass is below the right side of the capstan cover, shims P/N 1765648 (.010 inches thick) and P/N 1765649 (.030 inches thick) must be installed to create an interference condition.

Remove .010 inches of shims by modifying the number of shims in the shim package. Recheck the top of the door glass to the right side of the capstan cover relationship. Repeat this procedure until the door glass clears the bottom of the right side of the capstan cover and contacts the round portion of the capstan cover. When this condition is met, the adjustment is complete.

Note: Contact of the door glass on the capstan cover may cause the cover to shift. Care must be taken to insure the capstan cover is in its normal position each time the above check is made.

Remove the capstan cover.

CHECKS AND ADJUSTMENTS (CONT'D)

C. Capstan

1. Squaring (08-120)

- a. Capstan squaring, when maladjusted causes problems in the load/rewind/unload area; however, marginal tach operation may result in read/write errors.
- b. Loss of capstan tach pulse during high speed rewind or step down will cause reel board failures.
- c. MLM procedures should be followed. Specifically, both Phase A and Phase B should be correctly adjusted, but A and B added algebraically must also be observed so that state lengths can be checked.

2. Tracking (08-150, 151, 160)

- a. Dynamic tracking is important, because it can cause intermittent read/write errors and tape edge damage. Poor tracking can cause the tape to strike the rear guide and curl up, or ride off the front ramp and curl down off the capstan.
- b. Incorrect tracking will produce uneven head wear and can cause damage to tape library.

3. Cleaning (See tape unit cleaning procedure GY32-5034 and MLM 85-000)

- a. Although this is not a direct area of CE responsibility, it does have a great effect on performance.
- b. Poor quality and/or frequency of customer capstan cleaning will cause start read checks, partial records (actual or false) and velocity checks.
- c. Poor cleaning of read/write head causes excessive temporary errors.

CHECKS AND ADJUSTMENTS (CONT'D)

D. Read/Write Components

1. Mechanical skew (08-170)

- a. The MLM for mechanical skew check and adjustment includes a procedure for checking and a separate procedure for doing the adjustment. When doing either of these procedures it must be realized that improper capstan tracking has a direct influence on mechanical skew.

2. Read amplitude adjustment (8-310) (Models 4,6,8)
For models other than 4,6,8, use amp sensor adjusting procedure in MLM.

- a. This adjustment is a PE adjustment although 6250 only has an adjustment pot for track 1 to adjust gain for 6250 ID burst.

- b. Adjustment procedure is in MLM 08-310 or as an alternative, the following procedure suggests using the analog signal from the read card for a sync while adjusting the read amp digital output.

- (1) Connect the field tester (with 3420 offline) and mount a good representative customer tape. Load and make ready.
- (2) Connect a jumper from T-A1N3B04 to ground and set tester to write forward continuously with frequency switch set to 32.
Note: The jumper enables the adjusting pots and also gives specific attenuation level to the circuits. The following adjustments produce a marginal condition (attenuated). With the jumper removed, the correct condition exists for normal operation.
- (3) Set scope to sync on channel 1, internal positive, high frequency reject; connect channel 1 scope probe to the read card analog test point for track P. (See decal for scope point).
- (4) Connect channel 2 scope probe to digital data track P. (See decal for scope point) Activate start on tape tester to begin writing.

CHECKS AND ADJUSTMENTS (CONT'D)

- (5) Using alternate sweep, adjust time base to view 2 cycles of analog data. Adjust track P pot clockwise until a solid square wave is observed. The analog sine wave should be symmetrical and undistorted. (Figure 1)
- (6) Now turn the pot counter-clockwise until the digital signal drop out is observed as a dim horizontal line through the square wave. At this time the analog signal should be 2V +/- .3V. (Figure 2)
If the pot is adjusted too far counter-clockwise, the square wave will disappear. (Figure 3)
- (7) Repeat steps 5 and 6 for all remaining tracks.

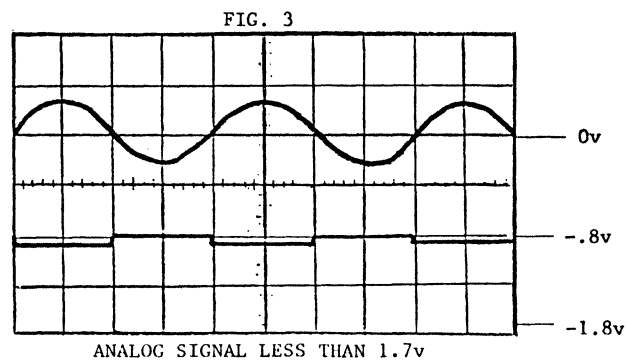
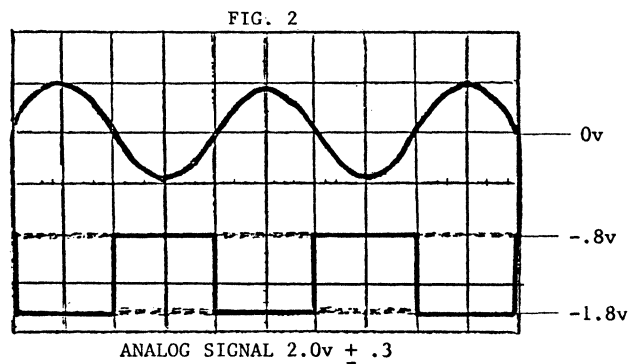
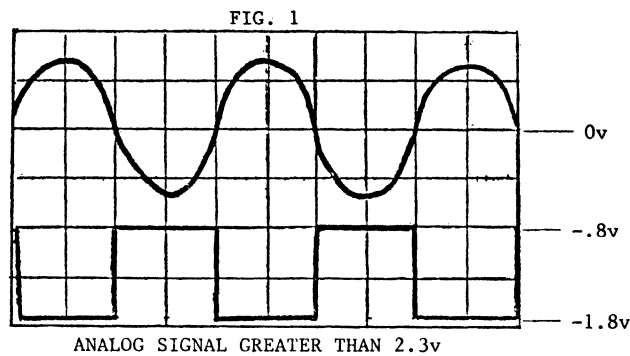

CHECKS AND ADJUSTMENTS (CONT'D)

3. Forward/Backward Ratio Test (Tape Unit Models 4,6, and 8)

Use this test to determine if a read/write head needs replacement.

Verify that the tape is tracking correctly before any head replacement. If frequent read/write head replacement is necessary, perform skew plate alignment procedure to insure proper tape to head (wrap) angle.

Perform Field Tester Accuracy check on 08-315 before proceeding.

- (1) Degauss the head (08-280) and the cleaner blade (08-390).
- (2) Install a jumper from K2P02-M2D06. This forces 6250 mode.
- (3) Obtain a customer good quality representative tape and write it at 6250 bpi on the unit being checked. Write it from the field tester with the frequency switch set at 64.
- (4) Read forward to the middle of the tape and remove jumper K2P02-M2D06 while tape is moving, then stop tape.
- (5) Set the Field Tester as follows:
ALT DIR
SLOW
READ
UP/FWD DN/BKWD Potentiometers all the way to the back of tester.
(Adjust DN/BKWD so tape has a forward creep rather than a backward creep).
- (6) Sync and scope the Read card test points to determine the forward to backward ratio. Display three or four cycles of read signal and use as much of the scope display as possible for measurements (.2v/cm). For ease of recording, scope H2M08 with another probe, this line will go negative when reading backwards.

- (7) If there is a read backward problem, and the amplitude in one direction is more than double the amplitude in the opposite direction on any one track, replace the read/write head. If read/write head replacement is required, perform the removal replacement procedure on 08-250, do required adjustments and return to the map that sent you here or 00-030. If replacement is not required, return to the map that sent you here or 00-030.

Note: If while making measurements, the tape gets back to load point, (resetting the 6250 latch) the jumper K2P02-M2D06 will have to be reinstalled while at load point and the tape read forward. This keeps the tape unit in 6250 without forcing a SAGC setup on every record. Remove the jumper and continue the test.

Each time the jumper is removed the SAGC may set up at a different value, but the ratio will remain the same.

CHECKS AND ADJUSTMENTS (CONT'D)

4. Read Forward/Backward Ratio Test (Tape Unit Models 3,5, and 7)

Use this test to determine if a read/write head needs replacement. If frequent read/write head replacement is necessary, perform skew plate alignment procedure to insure proper tape to head (wrap) angle.

Verify that the tape is tracking correctly before any head replacement.

Perform Field Tester Accuracy Check on 08-290 before proceeding.

- (1) Degauss the head (08-280) and the cleaner blades (08-390).
- (2) Obtain a customer good quality representative tape and write it at 1600 bpi on the unit being checked. Write it from the field tester with frequency switch set to 32.
- (3) Read forward to the middle of the reel of tape and stop tape.
- (4) Set the Field tester as follows:
ALT DIR
SLOW
READ
UP/FWD DN/BKWD. Potentiometers all the way to the back of tester. (Adjust DN/BKWD so tape has a forward creep rather than a backward creep).
- (5) Sync and scope the Read card test points to determine the forward ratio. Display three or four cycles of read signal and use as much of the scope display as possible for measurements (.2v/cm). For ease of recording, scope J2B13 with another probe, this line will go positive when reading backwards.
- (6) If there is a read backward problem, and the amplitude in the backward direction is less than that of the forward direction by 50% on any one track, or 60% on the remaining tracks, the read/write head should be replaced. If head replacement is required, perform the removal/replacement procedure on 08-250.

CHECKS AND ADJUSTMENTS (CONT'D)

5. Self Adjusting Gain Control (SAGC)

- a. Procedure on MLM 08-315 can be clarified as follows:
- b. Install jumper from T-AIM2D06 to T-A1K2P02, mount good quality customer tape, attach 3420 field tester and load tape without making it ready.
- c. With tester in start/stop, write and frequency equal 64, SYNC scope minus and look at T-A1K6B12 (-move tag). Adjust time base to 5MS/CM and .5V/CM. Adjust tester up/fwd - dn/bkwd pots so scope picture appears as (B) on Figure 1.
- d. Put the other scope probe on read card test point, hit start on field tester and display SAGC signal on scope. (A on Fig. 1). Minimum number of steps acceptable is 0 as shown. Maximum number of steps is 14, anything different is incorrect and problems could be write card, read/write head, read card; this criteria applies to all tracks.
Note: After set up of scope as in steps c and d, it may make observation easier if time base is switched to 2MS/CM.
- e. Make sure that after the analog signal reaches approximately 2V, it does not drop down in amplitude as (A) on Figure 2.

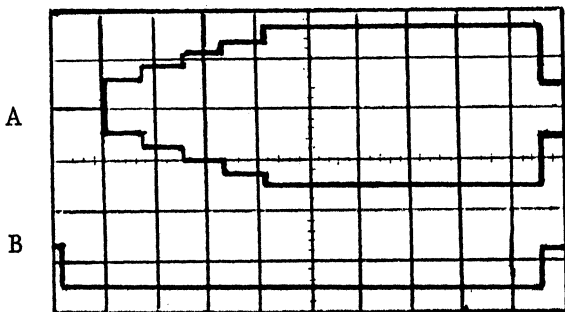

FIG. 1

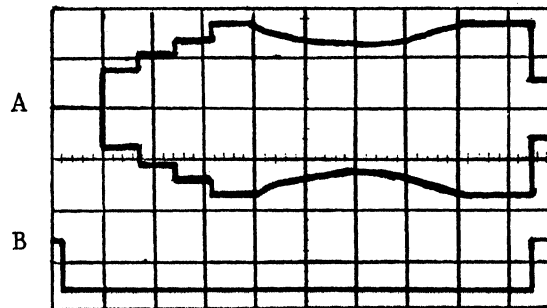

FIG. 2

3420 ACCOUNT CHECKLIST

ACCOUNT NAME _____

YES NO

HARDWARE

3420 HARDWARE CHECKLIST
3803 HARDWARE CHECKLIST

SOFTWARE

EREP RUNNING - 30 DAY HISTORY AVAILABLE
TSS - INSTALLED AND WORKING
OLTS - RELEASE 12.4 - RUNNING ONLINE

ACCOUNT TOOLS

SKEW TAPE
MASTER OUTPUT TAPE
3420 TAPE TESTER
VACUUM/PRESSURE GAUGE

CUSTOMER

ADEQUATE CLEANING PROCEDURES
MEDIA PROBLEMS HAVE BEEN ADDRESSED

CE'S

TREND TRAINED (LECTURE AND LAB)

COMMENTS :

3803 CHECKLIST

OK PROB

COOLING FILTER - CLEAN

ESD PLATES & LATCHES

PLATED IO CONNECTORS

SHIELDED SIGNAL CABLE GROUND

EPO CABLES INSTALLED & GROUNDED

CE PANEL - BULBS - SWITCHES

3420 CHECKLIST

SERIAL _____ MOD _____ ADR _____

OK PROB

- | | | |
|-------|-------|--|
| _____ | _____ | GENERAL DRIVE APPEARANCE - DIRTY, COVERS MISSING |
| _____ | _____ | OPERATOR PANEL - BUTTONS, LIGHTS |
| _____ | _____ | FILE PROTECT PLUNGER - BINDING |
| _____ | _____ | CARTRIDGE PRESENT PLUNGER - BINDING |
| _____ | _____ | UPPER CARTRIDGE RESTRAINT - BROKEN, BENT |
| _____ | _____ | LOWER CARTRIDGE RESTRAINT - GRAY OR BLACK CATCH |
| _____ | _____ | REEL HUB ROLLERS - WORN |
| _____ | _____ | REEL HUB RUBBER - WORN |
| _____ | _____ | MACHINE REEL - DIRTY, BROKEN, TAPE WRAPPED AROUND |
| _____ | _____ | CLEANER BLOCK - WIDE BLADES, WORN |
| _____ | _____ | ERASE HEAD - WEAR |
| _____ | _____ | AUTO-CLEANER - FREEDOM OF MOTION |
| _____ | _____ | R/W CARD - NOT SEATED, GROUND STRAP |
| _____ | _____ | REFERENCE PLATE - WORN |
| _____ | _____ | REEL TACHOMETER - WOBBLE, END PLAY, GLAZE |
| _____ | _____ | AIR BEARING - PLUGGED, POLISHED, LOW PRESSURE, DIRTY |
| _____ | _____ | STUBBY AND Z BARS - LOOSE, CAPSTAN CLEARANCE, WORN TAPE, DIRTY |
| _____ | _____ | VACUUM COLUMNS - WORN TAPE, DIRTY, LATCH ROLLERS WORN |
| _____ | _____ | VAC COL DOOR - GLASS SEALS, FLOAT PLATE SEALS, FOAM GOOD |
| _____ | _____ | CAPSTAN MOTOR - GLAZED, DENTED, TACH DAMAGE, CLEAN COOLING |
| _____ | _____ | SCREENS |
| _____ | _____ | TOROID - R/W CABLES AND WIRES THRU TOROID |
| _____ | _____ | PLASTIC COVER OVER R/W CARDS - MISSING |
| _____ | _____ | FIBER OPTIC LAMP - DISCOLORED (CHECK WHEN OFF WITH PEN LIGHT) |
| _____ | _____ | HOSES - OLD, CRACKED |
| _____ | _____ | EOT/BOT CAP ON 01A-A1D2B09 TO D08 |
| _____ | _____ | COOLING FILTER - CLEAN (BLUE SIDE UP) |
| _____ | _____ | REAR COVER ESD PLATES - MISSING, BENT |
| _____ | _____ | PNEUMATIC SUPPLY - BELTS WORN, LOOSE |
| _____ | _____ | I/O CONNECTOR - PLATED OR SHIELD CABLE GROUNDED |

COMMENTS



INTRODUCTION TO QUICK FIX MAPS

The QUICK FIX MAPS were written for the purpose of providing a quick fix for most of the problems by going from the symptom, directly to the most probable cause. They are not expected to fix all problems.

They are also useful when the problem is intermittent or disappears. In many cases, the problem can still be resolved by finding the symptom in the QUICK FIX MAPS and taking the action specified for that symptom.

QUICK FIX MAPS are used in the same way as 3420 MAPS. If the answer to a question on the left is no, proceed to the next step. If the answer is yes, take the action specified on the right.

If they do not fix the problem quickly, use the 3420 MAPS.

SECTION I

3420 LOAD FAILURES

1. Left reel turns counter clockwise on load. Check that fiber optics lamp is on. Check EOT/BOT adjustments. Should be less than 2.0V with tape not present. If not, check for dirt in EOT/BOT photocells. Clean EOT/BOT mirror.

2. A. Tape fails to leave cartridge. Is pump motor running? If not, go to MAP 2A-130. If it is, check for broken belt.
B. Tape sticks on threading chute without cartridge.
C. Tape threads into right column.

3. Tape fails to load onto left reel. Check vacuum belt and hoses. Transfer valve probably leaking. Perform transfer valve leakage test as follows: Open vacuum column door. Hold load rewind button depressed. Right reel will not turn. Manually turn right reel, causing tape to thread through tape path till end of tape is above left vacuum column. Close vacuum column door. If end of tape is pulled into left column, replace transfer valve.

4. Load check after tape wraps on left reel. Reels loaded switch did not close. Check pressure at file protect port. If bad, look for broken hose. If good, replace reels loaded switch. This could also be caused by low pressure at the reels loaded port, due to dirt in three way valve or leakage behind reference plate because of loose left reel tach.

5. Tape fails to load into columns. No load check. Air bearing or reel hub pressure switch not closing. If transfer valve is still picked, check for shorted capacitor across solenoid pick relay. If solenoid is not picked but shaft is sticking out of left end of three way valve, correct the bind in this shaft or replace transfer valve. Go to step 9.

3420/3803 REFERENCE GUIDE

- | | |
|---|---|
| 6. Tape loads into only 1 column. | Probable vacuum column door leak or vacuum column balance. Check for proper seating of vacuum column door. Refer to Section 7.4. |
| 7. Tape loads into both columns but is jerked out by capstan. | Check capstan squaring. |
| 8. Tape drifts to bottom of column after load. | Tape fails to rewind to load point. Capstan motor failed to start. Check capstan motor for binds. Perform ohmeter test of capstan motor as follows:
Unplug capstan motor.
Set CE meter to RX1 and connect to leads of capstan motor plug. It should read a few ohms. Slowly rotate motor while observing meter. If at any point the meter shows open, replace the motor. Swap capstan control board.
Note: This problem can also be caused by R4 or L4 opening. This could be due to a bad switch, low vacuum or improper seating of the vacuum column door. |
| 9. You got here from Step 5
Check pressure at file protect port on 3 way valve.
Is pressure low? | If pressure will not adjust, check for broken hose. Check for clogged filter at input to pressure pump. Check for clogged absolute filter. If everything checks good, replace the pump. |
| 10. Check pressure at reel hub pressure switch. Is pressure low ? | Leak in reel hub operating assembly. Probably leaking through grease seals of bearings. Replace assembly. or replace bearings with P/N 355138. |
| 11. Bad pressure switch MOD
3-5-7, Scope E2M03. MOD
4-6-8, Scope D4M03. Should be 0 volts. Is it minus? | Replace air bearing pressure switch. |
| 12. MOD 3-5-7, Scope E2J02
MOD 4-6-8, Scope D4J02
Is it minus? | Replace reel hub pressure switch. |

3420/3803 REFERENCE GUIDE

13. Has it stopped failing?

Make sure pressure is good at file protect port and at reels loaded pressure switch. Replace air bearing and reel hub pressure switches.

14. Go to MAP 2A-160 or MAP 2B-160.

SECTION 2

3420 DROP READY PROBLEMS

1. Is the tape still on the drive?
Is the tape sticking to the head or is the tape in either column stretched? If so, the problem was caused by the tape.
2. Does the drive work from the tester but fail on first select from the system?
Check EOT/BOT adjustment. If tape ran backward past load point, check for pushed in pins on signal cable.
3. Has the tape bottomed or pulled out of either column?
Check for dirty lamp. Check capstan squaring. If it has overtrace or waterfall greater than 10%, clean capstan mirror. Check for loose leads to optics lamp by flexing all the leads to the lamp connector block while scoping capstan squaring. If pulse duration changes, a connection is loose. Try flexing the capstan fiber optics bundle while scoping capstan squaring. Pulse duration should not change. If capstan pulses are still bad, replace the capstan motor. Check column vacuum. Check for loose vacuum hoses and proper seating of vacuum column door. Load a tape and check operation of switches by moving the tape past the switch ports while scoping the switches on FT 451. If no problem is found and machine is still failing, replace all switches in the failing column. If both columns fail replace lamp.
4. Is sense data available?
NOTE: If running under an operating system, the sense bytes should be available on an online console. If not, EREP can be run to get the sense bytes. If running OLTEP, the sense bytes will be in the OLTEP output. In either case, it is too late to scope the error latches in the 3420. They have been reset by a sense command. The error latches are useful only when running from the 3803 or 3420 tester. Go to step 5.

5. Is Byte 18 Bit 0 on? Power check or air flow. Check filter. Check voltages. Scope ripple -4 and +6 volts. If no trouble found, replace UV/OV card in power supply.
6. Is Byte 7 Bit 3 on? Reset button was pressed or door opened. Check door interlock switch adjustment.
7. Is Byte 7 Bit 0 on? Lamp failure. Check for loose leads to optics lamp. Replace lamp.
8. Is Byte 7 Bit 6 on? Pressure failure. Check pressure at file protect port on 3 way valve. Check pressure at reel hub pressure switch. If pressure is good, replace all vacuum switches* for failing column. NOTE: Byte 7 bit 2, tape bottom right occurs if tape ran off the end of reel. This usually happens on a read operation because the system is looking for something that is not on the tape.
10. Is Byte 7 Bit 5 on? Erase current failure. Check for loose connector on top of write card. Check for loose connection on erase head. Scope ripple on +6 and -4 volts. Replace write card. Replace NFP relay assembly. Replace M2 card.
11. Drop ready with no sense bits to indicate why. Check items at right. If problem has not been resolved, proceed to step 12.
- PROBABLE CAUSES:
1. Air bearing pressure or reel hub pressure switch. Check pressure at file protect port and pressure to reel hub pressure switch. Scope reel hub pressure switch at E2J02 on MOD 3-5-7 or at D4J02 on MOD 4-6-8. Scope reels loaded switch at E2M03 on MOD 3-5-7 or at D4M03 on MOD 4-6-8. If either point is not a good ground level with tape loaded, replace the switch.
 2. Lamp failure. Check for loose lead to optics lamp. Tap on lamp manifold to try to reproduce failure.
 3. Power on reset caused by fuse detect and EPO card in power supply.

* Check decal. If vacuum switch P/M is due, install P/M kit.

3420/3803 REFERENCE GUIDE

12. Trouble shooting intermittent drop ready problems with MST 1 latch card P/N 5851882. If it will not fail from tester, run OLTEP with latch card connected. If it fails only on customer programs, connect latch card and return to customer.
13. Plug latch card on back panel with components to right. Test both latches by putting a jumper pin from pin A on each latch to any D08 pin. Both lamps should light.
14. Is this a MOD 3-5-7? Wire latch card as in Chart C. Page 8.9. Run till failure occurs. Go to step 18.
15. MOD 4-6-8? Wire latch card as in Chart A. Page 8.9. Run till failure occurs. Go to step 16.
16. Is latch 1 on? Wire latch card as in Chart C. Page 8.9. Run till failure occurs. Go to step 18.
17. Is latch 2 on? Wire latch card as in Chart B. Page 8.9. Run till failure occurs. Go to step 26.
18. Is latch 2 on? Wire latch card as in Chart E. Page 8.10. Run till failure occurs. Go to step 20.
19. Is latch 1 on? Wire latch card as in Chart D. Page 8.9. Run till failure occurs. Go to step 22.
20. Is latch 2 on? Power on reset. Replace fuse detect and EPO card in power supply.
21. Is latch 1 on? Lamp failure. Check for loose leads to optics lamp. Try tapping on lamp manifold to reproduce failure. Replace lamp.

22. Is latch 2 on? Pressure failure. Check pressure at file protect port on 3 way valve. Check pressure at reel hub pressure switch. If pressure is low, correct pressure problem. If pressure is good, replace air bearing and reel hub pressure switches. Check decal, install transport switch P/M Kit if due.
23. Is latch 1 on? Tape bottomed. Check vacuum. Check for proper seating of vacuum column door. Replace R4 and L4 vacuum switches. If problem is not corrected, wire latch card as in Chart F Page 8.10. Run till failure occurs. Go to step 24.
24. Is latch 1 on? Tape bottom left. Install vacuum switch PM Kit.
25. Is latch 2 on? Tape bottom right. Install vacuum switch PM Kit.
26. Are both latches on? Check safety bail adjustment.
27. Is latch 2 on? Write current or erase current failure. Check for loose connector on top of write card. Check for loose connector on erase head. Scope ripple on +6 and -4 volts. Replace write card, NFP relay assembly, and M2 card.

3420/3803 REFERENCE GUIDE

CHART A

LATCH 1

Pin A C2D04 - Mechanical ready	FT266
Pin C C2B09 + Power on reset	FT266

LATCH 2

Pin D C2B07 + Safety bail or write/erase current failure	FT266
Pin F C2J13 - Gated ready	FT261

CHART B

MOD 4-6-8 ONLY

LATCH 1

Pin D K2D12 + Safety bail reset	FT182
Pin F K2B12 - Gated ready	FT182

LATCH 2

Same as in Figure A

CHART C

LATCH 1	MOD 3-5-7	MOD 4-6-8	
Pin A	H2J06	M2J06 + Tape bottomed	FT114
Pin C	H2P05	M2P05 + Air pressure failure	FT114

LATCH 2

Pin A	H2S07	M2S07 + Lamp off	FT114
Pin C	C2B09	C2B09 + Power on reset	FT266

CHART D

LATCH 1	MOD 3-5-7	MOD 4-6-8	
Pin A	H2J06	M2J06 + Tape bottomed	FT114

LATCH 2

Pin A	H2P05	M1P05 + Air pressure failure	FT114
-------	-------	------------------------------	-------

3420/3803 REFERENCE GUIDE

CHART E

LATCH 1	MOD 3-5-7	MOD 4-6-8	
Pin A	H2S07	M2S07 + Lamp off	FT114
LATCH 2			
Pin A	C2B09	C2B09 + Power on reset	FT266

CHART F

LATCH 1	MOD 3-5-7	MOD 4-6-8	
Pin A	C2U13	C2U13 + Left bottom	FT264
Pin D	H2J06	M2J06 + Tape bottomed	FT114
LATCH 2			
Pin A	C2U09	C2U09 + Right bottom	FT264
Pin D	C2S05	C2S05 + Tape bottomed	FT264

CHART G

LATCH 1	MOD 3-5-7	MOD 4-6-8	
Pin D	H2P05	M2P05 + Air pressure fail	FT114
Pin F	E2M03	D4M03 + Air bearing switch	FT285
LATCH 2			
Pin D	E2D12	D4D12 + Air pressure fail	FT285
Pin F	E2J02	D4J02 + Reel hub pressure switch	FT285

SECTION 3

3420 DATA CHECKS AND EQUIPMENT CHECKS

1. Visual check. Check entire tape path. Look for objects stuck to air bearings, cleaner block, erase head, R/W head, left threading ramp, filler block or rewind plunger. On Model 3-5-7, check for binding rewind plunger. On Model 4-6-8, check autocleaner ribbon. It should not have any slack in it and the left edge should be just touching the R/W head. Check that read and write card are properly seated on the head. Check capstan for bind or missing rubber. If capstan is slick, refer to MLM 08-700 for cleaning procedure.
2. Check column vacuum and air bearing pressure.
3. Check capstan squaring.
4. Obtain CSW and sense byte from online console, EREP, or OLTEP output.
5. Is Byte 18 Bit 0 on? Power check. Check voltages. Scope ripple on +6 and -4 volts.
6. Unit check with no bits in Byte 0. Is Byte 1 Bit 7 on? Not capable. Make sure the tape is of a density which can be read on this drive. Check for dirty head. On Model 3-5-7, check for binding rewind plunger. On Model 4-6-8, check auto cleaner ribbon. If no trouble is found, run OLTEP.
7. Unit check with no bits in Byte 0. Is Byte 5 Bit 3 on? On Model 3-5-7, check for binding rewind plunger. On Model 4-6-8, check auto-cleaner ribbon adjustment. Check for bind in autocleaner. Go to step 13.
8. Byte 3 Bit 1 on with no other bits in Byte 3? Phase shift errors. Replace R/W head. Go to step 20.
9. Byte 10 Bit 7 or Byte 10 Bit 5 on? Velocity check or tach start failure? Check for binding capstan. Check capstan squaring. Check air bearing pressure. Check for proper tape loops in stubby columns. Refer to MLM 6B-150. If it will fail on OLTEP, swap the capstan control board, then capstan motor. If it fails only on customer jobs but not on a good OLTEP tape, it could be a tape stick problem. Try to find the tape on which the problem occurred. If it fails only on certain tapes, it is not a hardware problem.

3420/3803 REFERENCE GUIDE

10. Byte 10 Bit 3?
No Block Detected
on Write/WTM. Go to step 11.
NOTE: This error is frequently caused
by dirt build up on the head during
write error recovery with a dirty tape.
11. Byte 0 Bit 4 and Byte
1 Bit 5 on? Write
data checks. If checks in steps 1, 2 and 3 have been
completed, check dynamic tracking. Go
to step 13.
12. Byte 0 Bit 4 on and
Byte 1 Bit 5 off?
Read data check. Go to step 18.
13. MOD 3-5-7? Go to step 15.
14. MOD 4-6-8? Make sure head is clean. Use a good tape.
Check SAGC as shown in Section 7. If in any
track, SAGC starts to set up, drops off
and sets up again, replace the read card.
IF SAGC looks bad mostly in track 4 or 5,
check dynamic tracking. If SAGC does not
set up to approximately 2 volts on all
tracks within 10 steps or if amplitude
in any track drops .5 volts or more
after reaching full amplitude, replace
the R/W head and go to step 20. If no
trouble found, go to step 16.
15. MOD 3-5-7
Write data checks. Adjust preamps using the attenuator card
specified in MLM's. If any track gives
overtrace over a wide range of adjustment
check tape tracking. If no help, scope
preamps at the point where the attenuator
card is normally plugged. Check forward
to backward signal ratio. If backward
is less than 50% of forward or there is
wide variation in amplitude on track 4
or 5, the head is worn and must be
replaced. After replacing head, go to
step 20. If no trouble is found, go
to step 16.
16. Does OLTEP fail? Swap read card with another drive, adjust
preamp. If it still fails, swap write
card. If this is a MOD 4-6-8, check
jumpers on write card. If it still fails,
replace R/W head and go to step 20.

3420/3803 REFERENCE GUIDE

- | | |
|--|--|
| 17. Everything looks good from tester. OLTEP runs clean but EREP indicates write errors. | Take the same actions as in step 16 and watch future EREPS to determine if problem has been corrected. |
| 18. Read data check | Does this tape read on another drive? If so, check tracking and skew on this drive. If not, try to determine where the tape was written and go to step 19. |
| 19. This drive has written an unreadable tape. | Check tracking and mechanical skew. Check air bearing pressure and column vacuum. Check capstan for binds or missing rubber. Check capstan squaring. If capstan is slick, refer to MLM 08-700 for cleaning procedure. |
| 20. R/W head has been replaced. | Check dynamic tracking if it has not already been checked. Adjust amp sensors On Model 4-6-8, check SAGC Section 7. If it does not look good, the new head may be defective. Try another head. Adjust mechanical skew. On Model 3-5-7 with the 800BPI feature, adjust electrical skew. |

SECTION 4
MISC

UNLOAD FAILURES

1. Tape comes out of columns but wraps on left reel. Reels loaded switch not transferred. Check pressure at file protect port. If bad, look for broken or loose pressure hose. If good, replace reels loaded switch.
2. Right reel does not stop turning after unloaded. Probably has dirt in EOT/BOT photo cells. Check EOT/BOT adjustment. Should be less than 2.0 volts with no tape present.

FAILS TO HIGH SPEED REWIND

Note: If EC847234 is installed, check for missing capstan tach pulses. This EC prevents blowing reel boards by dropping the tape drive into low speed rewind (Mod 4,6,8).

1. Does it fail to enter high speed rewind? Scope output of left reel tach at D2G07. This can be scoped by just spinning the reel tach. If no pulse, look for disconnected fiber optics for the failing tach.
2. Does it enter high speed rewind, but drop into low speed? If tape is pulling out of left column, replace L1 switch. If tape bottoms in right column, replace R3 switch. If it cannot be determined which column is at fault, replace L1 and R3 switches.

BROKEN OR STRETCHED TAPE

Check for bind in left and right reel tachs. Check capstan squaring.
NOTE: Look for an extra load point sticker or missing oxide on the damaged tape near the damage. If a load point is recognized while in high speed rewind, the tape will be damaged.

FILE PROTECT PROBLEMS

1. File protect light stays on with ring in reel. Load a tape with ring in reel. Check pressure at file protect port. If bad, look for broken or loose hose. If good, go to step 2.
2. Check voltage on both sides of NFP pressure switch. Should be +6 volts. Is either side 0 volts? NFP switch not transferred. Check pressure at NFP pressure switch. If good, replace NFP pressure switch. If bad, replace file protect assembly.
NOTE: The pressure out of this assembly

is usually lower than the pressure into it because of normal leakage. Problems usually occur with a reading of approximately 45 or lower.

3. MOD 3-5-7?

Go to step 5.

4. MOD 4-6-8?

Scope K2B02.
Should be +12
volts. If not,
perform action at
right.

Replace NFP relay or NFP relay assembly.

5. Scope H2M10.

Should be +6
volts. If not,
perform action
at right.

Replace NFP relay or NFP relay assembly.

FOLDS AT BEGINNING OF TAPE

Caused by leaking transfer valve. Tape hits left reel tach on load operation, then is deflected upward to the left reel. Perform transfer valve leakage test as in SECTION 1 step 3.

EXCESSIVE WHITE POWDER
ON LOWER RESTRAINT,
CAUSING TAPE
CONTAMINATION

Reel rubbing on cartridge. Check for proper retaining button (black or gray) in lower restraint. Check reel alignment with tool kit P/N 2515401.



3803-2/3420-3 THROUGH 8 TAPE DRIVE SENSE ANALYSIS (1 of 7)

When troubleshooting the 3803-2/3420-3 through 8 Subsystem use:
This chart:

- o For Single Drive failures when sense data is available.
- o As a supplement to MLM 00-009 and 00-005.

Note: Contamination can appear as a multiple drive failure but it is really drive oriented.

MLM 00-010 is the normal entry point for the Symptom Index.

MLM 00-011 and 00-012;

- o For Permanent Read errors plus the tape develop procedure in this package.

MLM 14-000;

- o For 3803-2 problems.

Tips

- (A) Developing tape can be very helpful to determine what kind of failure really happened.
- (B) Review 3803/3420 Service Aids on microfiche.
- (C) Always clean the R/W head before adjusting the AMP Sensors. A build up in the head slots can make it difficult to clean thoroughly at times.
- (D) R/W card to head plugging, if pins are not making good contact, it may fail with vibrations. The signal ground connection, if not made, will produce intermittent problems in R/W.
- (E) Compatibility problems between drives can be caused by tracking out of adjustment. Or if this adjustment is OK, and the tracks are not centered on tape. Develop tape and place it on the viewer to observe. The proper positioning of the head to tape relationship is done by the Skew Plate. A special Skew Plate adjusting tool is necessary to do this (included in the Reference Plate replacement kit, BM 4298806).
- (F) Check power supply voltages.

3803-2/3420-3 THROUGH 8 TAPE DRIVE SENSE ANALYSIS (2 of 7) (continued)

Note: Sense byte bits are in the order of their importance except bits in byte 10.

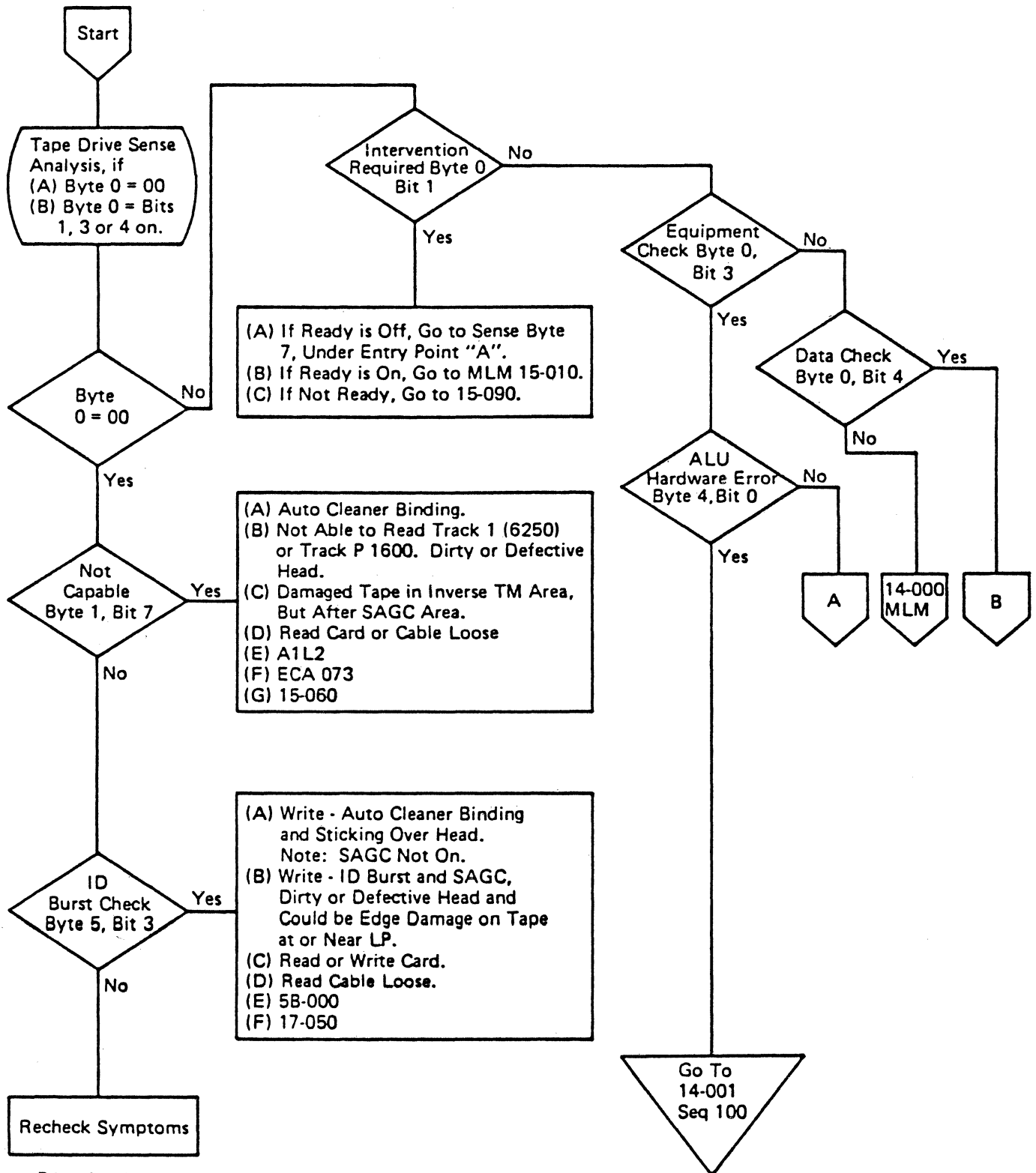

3803-2/3420-3 THROUGH 8 TAPE DRIVE SENSE ANALYSIS (3 of 7) (continued)

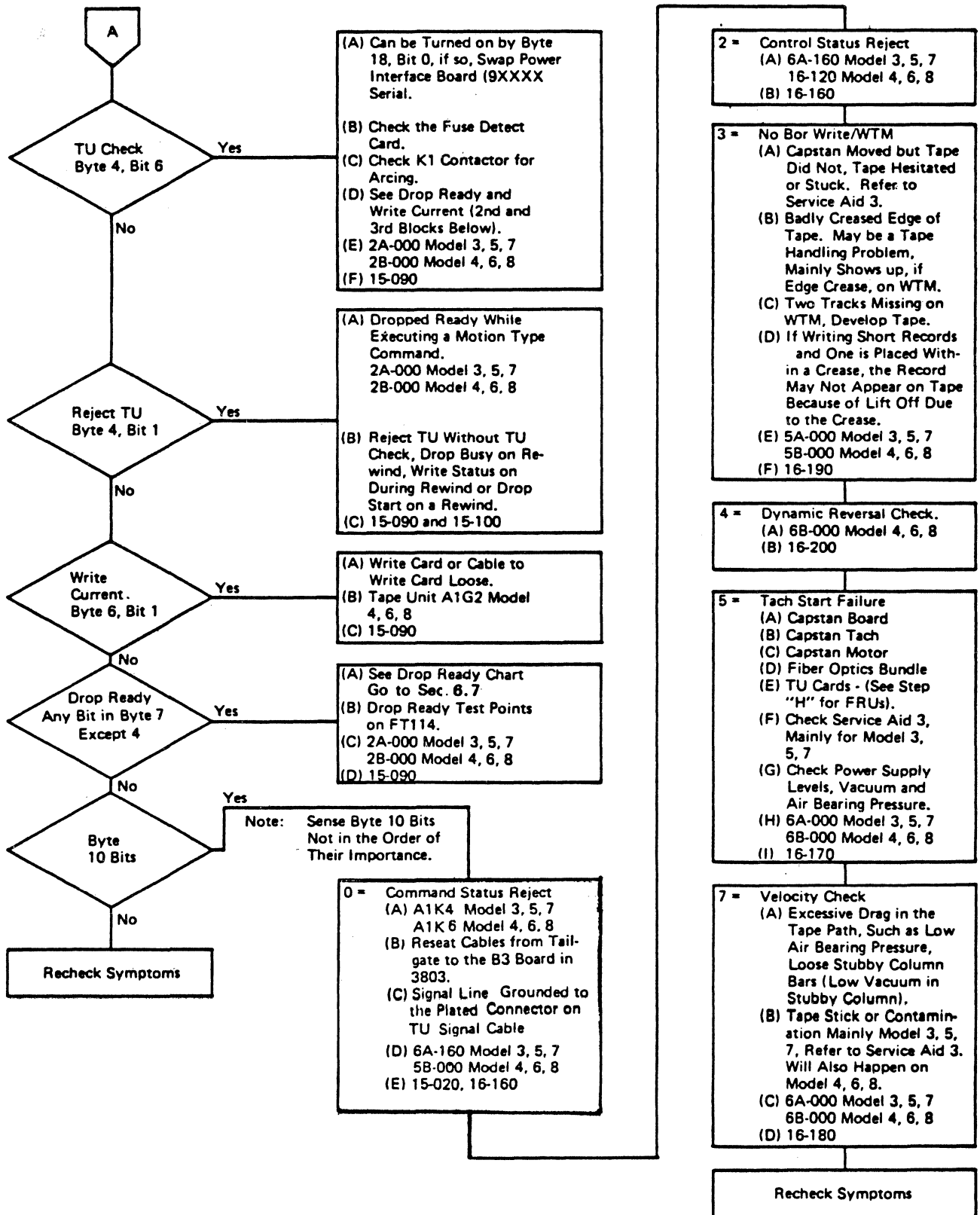

3803-2/3420-3 THROUGH 8 TAPE DRIVE SENSE ANALYSIS
(4 of 7) (continued)

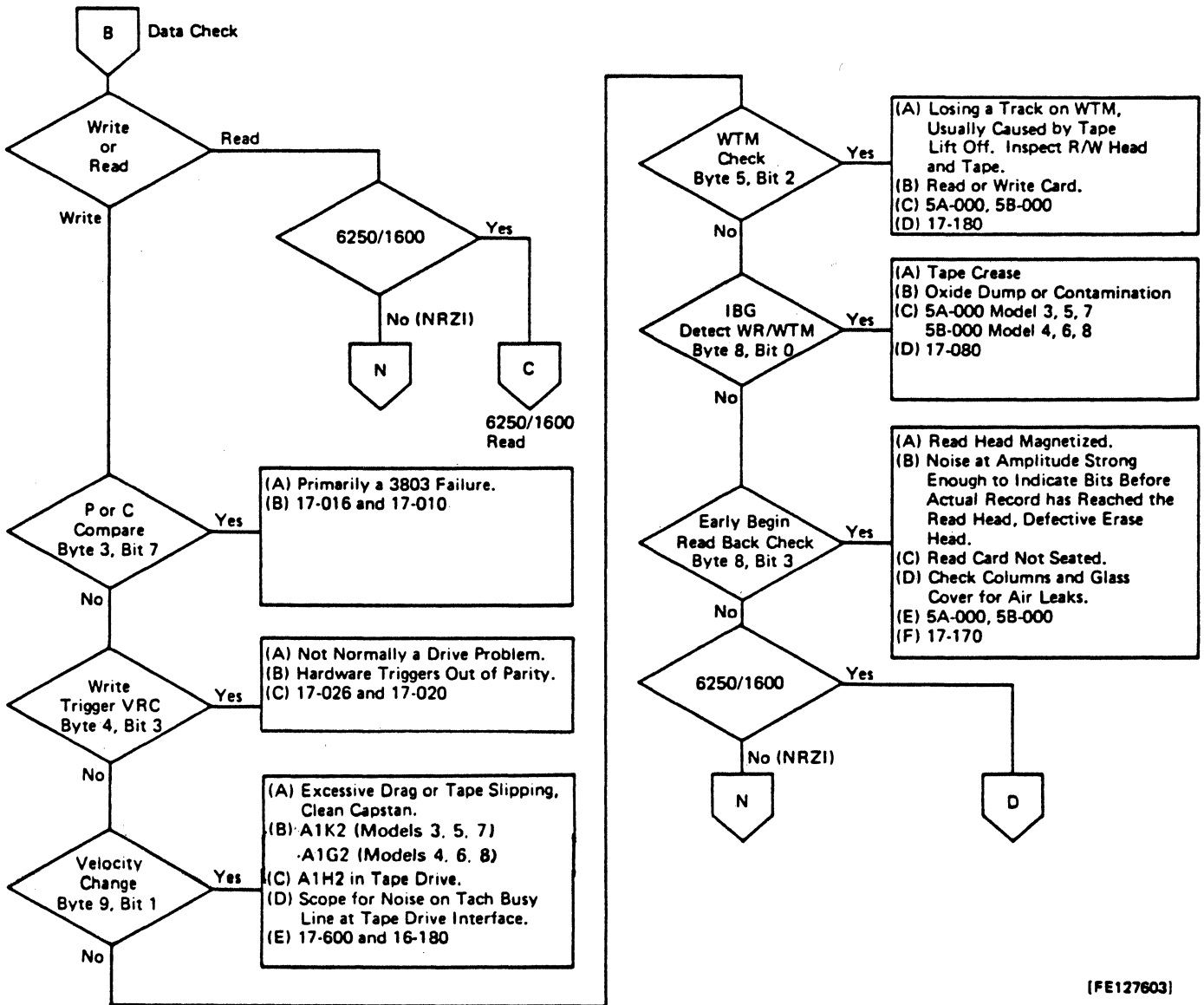

(FE127603)

3803-2/3420-3 THROUGH 8 TAPE DRIVE SENSE ANALYSIS (5 of 7) (continued)

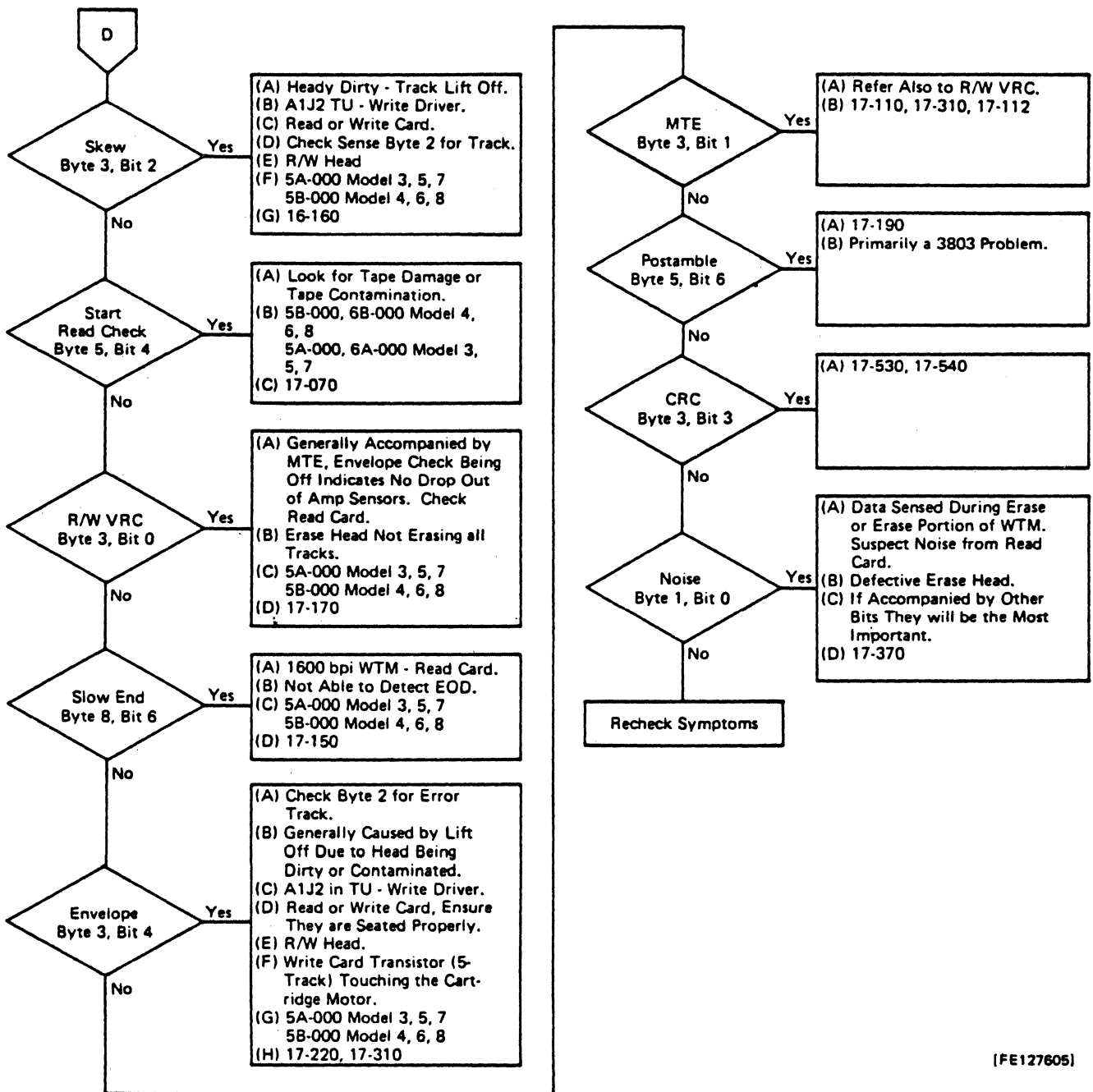

3803-2/3420-3 THROUGH 8 TAPE DRIVE SENSE ANALYSIS (6 of 7) (continued)

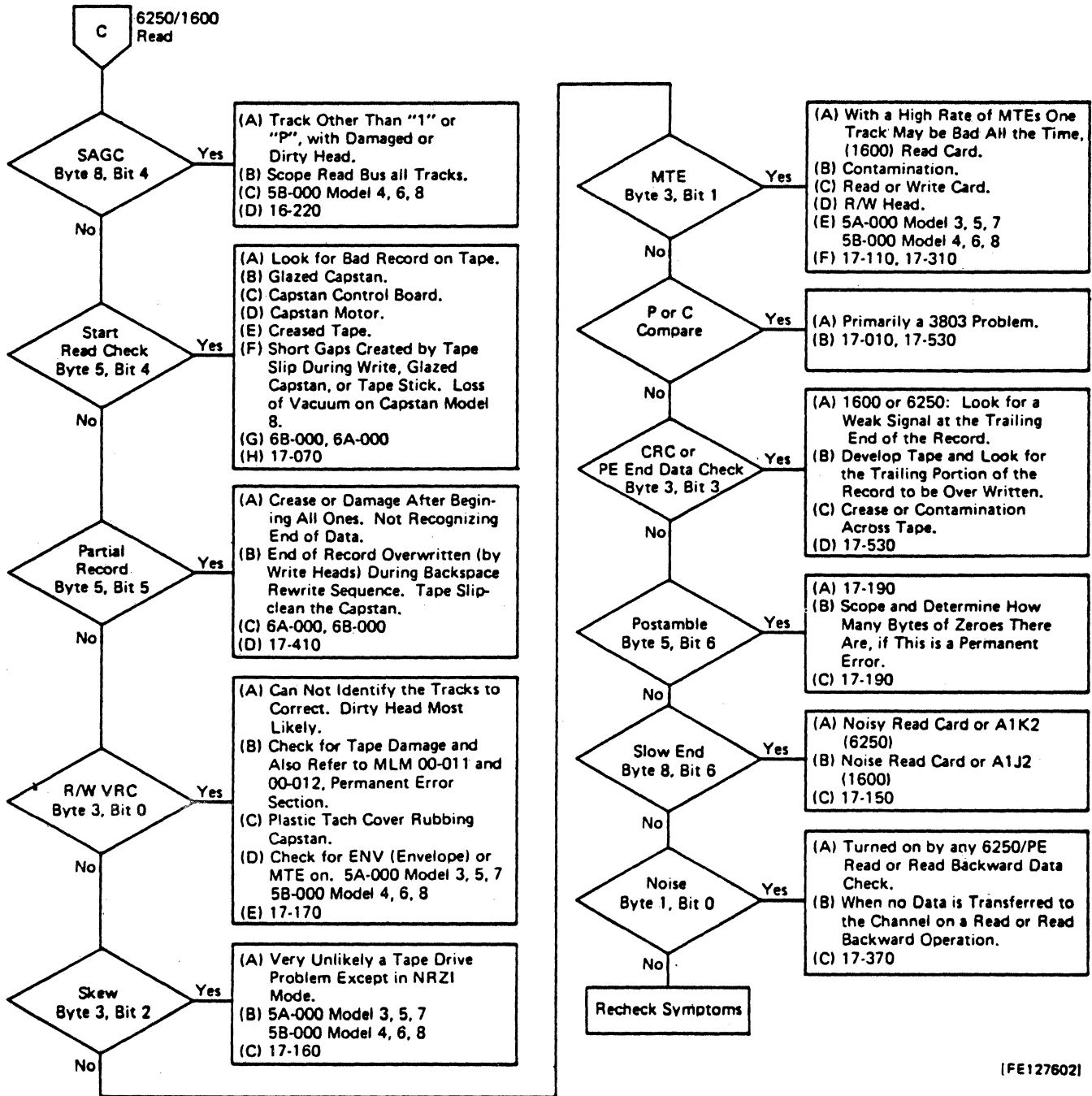

[FE127602]

3803-2/3420-3 THROUGH 8 TAPE DRIVE SENSE ANALYSIS
(7 of 7) (continued)

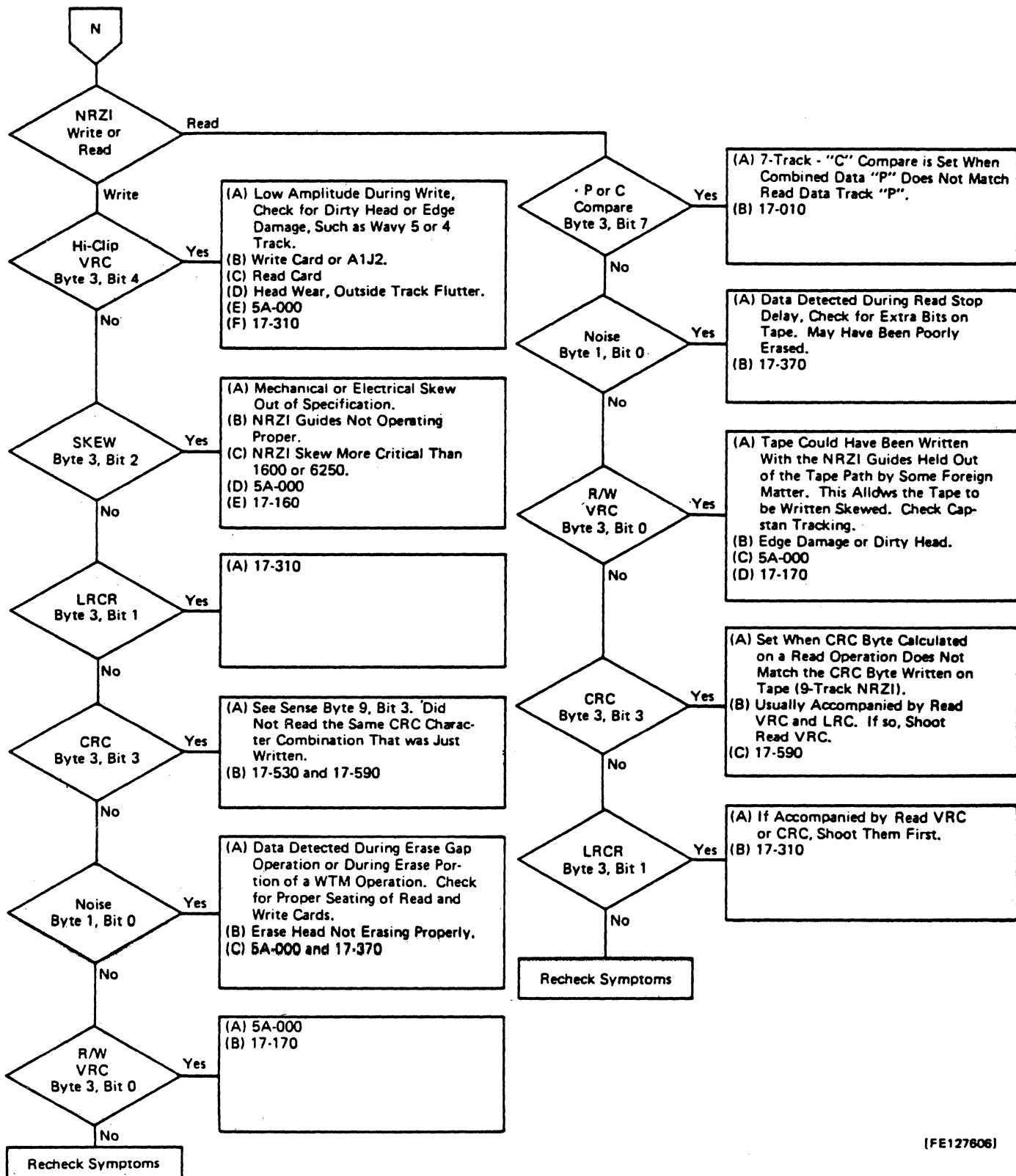

(FE127606)



MAGNETIC TAPE

Most of the recording media in today's digital record environment is a polyethylene terephthalate film, (mylar*), coated on one side with a flexible thin layer of ferromagnetic material. The tape is slit to .498+.002" wide and reflective stickers are mounted at each end to mark the beginning and end of the usable area of tape. Tapes come in two standard lengths, 1200 and 2400 feet.

Tape can deteriorate due to conditions encountered in storage, handling, or operating on drives. This degradation will show up as an increasing number of temporary write or read errors during its use until the damage gets extensive enough to cause a permanent error.

When storing tape it should be stored in an area where the temperature is between 40 degrees to 90 degrees F (4 degrees to 32 degrees C) and 20 to 80 percent relative humidity (nominally 70 degrees F at 35 percent relative humidity). To operate, tape should be at 60 degrees to 90 degrees F (16 degrees to 32 degrees C) and 20 to 80 percent relative humidity (nominally 75 degrees F at 45 to 50 percent relative humidity). When tape is exposed to temperature in excess of the above criteria, degraded operations may occur. Tape should be acclimated to the operating temperature for at least 24 hours before use if large environmental changes are encountered in storage or use.

When a reel of tape exceeds a specified number of errors, it is recommended the tape be removed from service. The specified number will vary from customer to customer. It is dependent on several parameters of the total system operation.

Details of tape properties essential for IBM tape units are found in IBM manual, GA32-0006, tape requirements for IBM one-half inch tape unit at: 556, 800, 1600, and 6250 bpi.

*Trademark of E.I. duPont de Nemours & Co. (Inc.)

COMMON MEDIA RELATED PROBLEMS

Unevenness of Tape Wind (Staggered Wraps)

3420/3803 Service Aid 4

The manner in which a tape stacks on a reel when rewound is a product of three factors: The drive, the tape and the reel. These all contribute, however, in an individual case, any one of these may be predominant. Some items that are pertinent to this matter are:

1. Some irregularity of wind is to be expected. It is caused by aerodynamics (escaping air forming a cushion between layers), and static electricity which will attract or repel the tape to or from a flange in varying degrees as the tape is wound.
2. A perfectly smooth wind (from a 3420 drive) is not necessarily desirable as it tends to indicate the tape is being forced against one of the flanges or other guiding surfaces.
3. If the wind is irregular, no damage to the tape will result unless poor handling practices are followed; ie, pressure applied to the reel flanges causing a tape edge to be bent over. This may be due to improper stacking of multiple reels not in containers, or cartridges not designed to be stacked. Also by squeezing the flanges while handling or mounting a tape.
4. The flanges of the reel are not designed to guide the tape or help it wind smoothly. The flanges are there only to protect the tape during shipping and handling, and then only to protect it from something bumping the tape edges, not from pressures of such force as to bend the flanges.

Devices can be developed which will wind the tape smooth. You will note new tapes received by customers have a smooth wind. The field situation does not warrant installing and maintaining such a device on field drives.

With each complaint or concern of staggered wraps, the best approach to the problem is to adjust the drives as accurately as possible, as they are not producing unnecessarily poor winds. Inspect the drives for any possible condition that may indicate wear or interference in the tape path.* After it has been determined that the mechanical alignment of the transport is acceptable, the customer should be instructed on proper handling techniques for magnetic tape.

*See page 4 of this section.

Z FOLDS

Z folds are usually caused by loose wraps on the tape reel. When tape is loaded on the machine, the loose outer wraps are pulled tight against loose inner wraps causing the Z-Fold.

Z-folds can be avoided by adequate customer controls in tape handling and library management. Z-folds can also be reduced by the following:

1. Properly crimping the end of the tape leader.
2. ECA 113 EC 846437
3. ECA 115 EC 847217

Some other causes of Z-folds:

1. Stubby bar adjustment
2. Transfer valve

TAPE EDGE DAMAGE

Tape edge damage can be caused by improper tape handling. Example: tape reel has uneven wraps and the sides of the reel are squeezed thereby creasing the tape.

Some other causes of tape edge damage are:

1. Capstan tracking
2. Worn reel tachs
3. Reel hub alignment
4. Upper or lower restraint broken
5. Cartridge retaining button missing
6. Worn reel hubs

OXIDE VOIDS (Missing Oxide)

Oxide voids can be caused by bad tape or a worn tape cleaner block. Tape cleaner block should be replaced every 12 months. (MLM 85-005)

*****SYMPTOM*****

Machine reel spreads and rear flange binds against the casting usually causing rewind to fail. It can cause tape stretch or tape break.

PROBLEM ISOLATION AIDS

Check tape for edge damage and determine damaging tape unit. Possible causes are:

1. Capstan
2. Reel Tachometers
3. Reel Hubs

Capstan:

1. Check capstan surface for grooves, flatness and glazing.
2. Insure static alignment, 17/32 from reference plate to front of capstan is correct. Reference MLM 08-010 through 08-070.
3. Verify the dynamic alignment MLM 08-150 or 08-160 is correct.
4. After reassembly of the front guide in Item #3 above, insure that the tape does not distort from rubbing against the front guide or reference plate on long forward or backward tape motion operations.

TAPE MOTION OPERATIONS

5. After doing capstan dynamic alignment verify by checking mechanical skew forward and backward. MLM 08-170.

REEL TACHOMETERS

1. Check wear in bearing. Excessive wobble or binding of the reel tach can cause tape edge damage.
2. Check clearance of the tape edge to the reference plate and to the front alignment ridge of the reel tach. Do this by pulling a short piece of tape across the tach while looking for tape edge distortion. If tape edge is distorted, replace reel tach.

REEL HUB

1. Verify reel hubs are in good repair. Replace missing or broken parts on the right reel and warped or damaged flanges on the left reel.
2. Check reel hub alignment. Refer to MLM 08-500 for the right reel and MLM 08-560 for the left reel.
3. Check for warped machine and file reels.

*****FIX*****

Replace or adjust any out of spec. conditions above.

IBM 3803/3420 ONLINE TESTS, LISTED BY SECTION

SECTION	DESCRIPTION	TEST FOCUS	TEST MODE
T3420 A	Executes all functional commands except data security erase in a sequence intended to detect and isolate hardware failures.	Control Unit	PE/6250/NRZI
T3420 B	This section tests basic functions of the control unit.	Control Unit	PE/6250/NRZI
T3420 C	Checks control units ability to execute backward commands at load point, to write and recognize tape masks, and to recognize load point.	Control Unit	PE and 6250
T3420 D	Checks 3803-2 channel buffer, and correct stepping of read-in counters (RIC) and read-out counters (ROC).	Control Unit	6250/1600/NRZI
T3420 E	Checks data transfer for all read and write commands for all modes except 7-track modes that use the translator feature.	Subsystem	PE/6250/NRZI
T3420 F	Checks data path of 3803-2 only (at 6250BPI only) and checks positioning of tape, write current and erase operations on both 3803-1 and 3803-2.	Control Unit	6250 Only
T3420 G	Tests 6250 error detection and correction only.	Control Unit	6250 Only

3420/3803 REFERENCE GUIDE

IBM 3803/3420 ONLINE TESTS, LISTED BY SECTION

SECTION	DESCRIPTION	TEST FOCUS	TEST MODE
T3420 H	Tests error detection, single-track error correction, and inhibit postamble and preamble.	Control Unit	PE Only
T3420 I	Tests ability to handle creased tape, phase errors, interblock gaps (IBG), data ready time-out, and beginning of records (BOR) in 1600BPI, and P.E. mode.	Control Unit	PE Only
T3420 J	Tests the ability of the subsystem to handle PE write skew and to recover from Phase errors on 3420 models 4, 6 and 8 dual density only.	Control Unit	PE Only
T3420 K	Tests PE read and write circuits, error detection, and error correction.	Control Unit	PE Only
T3420 L	Check PE clipping levels in 3420 Model 4, 6 and 8	Tape Unit	PE only
T3420 M	Checks control units ability to perform backward commands at load point, to write and recognize tape marks and recognize load point.	Control Unit	NRZI Only
T3420 N	Checks subsystem ability to do certain detection and correction functions in NRZI mode.	Control Unit	NRZI Only
T3420 O	Check subsystem ability to perform various functions in 7-track or 9-track NRZI mode.	Control Unit	NRZI Only

3420/3803 REFERENCE GUIDE

IBM 3803/3420 ONLINE TESTS, LISTED BY SECTION

SECTION	DESCRIPTION	TEST FOCUS	TEST MODE
T3420 P	Tests 7-track feature.	Tape Unit	NRZI Only
T3420 Q	Reliability test for subsystem data transfer circuits.	Subsystem	PE/6250/NRZI
T3420 R	Tape unit write reliability test.	Subsystem	PE/6250/NRZI
T3420 S	Checks tape unit read reliability by using tape generated by section T3420 R.	Subsystem	PE/6250/NRZI
T3420 T	Measures speed of capstan tach while moving tape at normal speed.	Tape Unit	PE/6250/NRZI
T3420 U	Measures capstan tach asymmetry for alternating forward and backward motion.	Tape Unit	PE/6250/NRZI
T3420 V	Measures tape units stop distance and start times	Tape Unit	PE/6250/NRZI
T3420 W	Measures the interblock gap (IBG) and forward creep of a tape unit.	Tape Unit	PE/6250/NRZI

3420/3803 REFERENCE GUIDE

IBM 3803/3420 ONLINE TESTS, LISTED BY SECTION

SECTION	DESCRIPTION	TEST FOCUS	TEST MODE
T3420 X	Diagnoses intermittent read and write failures.	Tape Unit	PE/6250/NRZI
T3420 Y	Checks read access time on tape unit, models 3, 5 and 7. Jumper is needed.	Tape Unit	PE/NRZI
T3420 Z	Checks read access time on tape units, models 3, 5 and 7. Jumper is needed.	Tape Unit	PE/6250
T3420 AB	Tests control units device switching features that permit more than one control unit to access a tape unit.	Control Unit	PE/6250/NRZI
T3420 AC	Tests the ability of the control unit to set, stack, and clear device end status.	Control Unit	PE/6250/NRZI
T3420 AD	Tests functions of two channel switch feature of 3803 control unit.	Control Unit	PE/6250/NRZI
T3420 AE	See T3420 AD	Control Unit	PE/6250/NRZI
T3420 AF	See T3420 AD	Control Unit	PE/6250/NRZI

3420/3803 REFERENCE GUIDE

IBM 3803/3420 ONLINE TESTS, LISTED BY SECTION

SECTION	DESCRIPTION	TEST FOCUS	TEST MODE
T3420 AG	See T3420 AD	Control Unit	PE/6250/NRZI
T3420 BA	Uses machine generated tape to test control unit logic not accessible to other diagnostics and to "stress" read detection/correction path beyond normal limits.	Control Unit	6250 Only
T3420 BB	Completes reading pre-written stress tape used in T3420 BA.	Control Unit	6250 Only
T3420 CA-CE	Prints user reference with suggestions that help to improve the effectiveness of the diagnostics.	Control Unit	6250 Only
T3420 RO-WR	Analyzes sense from other OLTS tests to call out FRU's in 3803-2.	Control Unit	3803-2
T3420 XA	Stress-tests the right and left reel systems of the tape unit.	Tape Unit	PE/6250/NRZI

HOW TO MAKE YOUR DIAGNOSTICS MORE EFFECTIVE

In general you should run diagnostics on a clean drive with known good tape. Diagnostics should be run on a regular basis to detect a deteriorating sub-system. The first good diagnostic run after installation should be saved for comparison to later runs. A good technique to aid in the detection and correction of intermittent read/write problem is as follows:

1. Obtain several marginally performing tapes from the customer.
2. Run T3420X on a known good drive using these tapes.
3. Run T3420X on the suspect drive using these tapes.

The results from steps 2 and 3 can then be compared. If both drives are performing properly they should have the same or very nearly the same amount of errors. The test tapes should be chosen so that the known good drive will not run error free.

3420 OLT GENERAL STRATEGY

In general, 3420 OLT diagnostics are designed to be run sequentially from A through Z. The CE should begin trouble shooting with the first error encountered. All of the sections that end with two letters (ex. T3420AB) are for testing special features or require CE action prior to execution.

NOTES BY OLT SECTION

- T3420AE, T3420AF - Unexpected interrupt problems. If running on a 303X processor, disable the high speed buffer and rerun.
- T3420K - Multiple error messages. If EC846276 is installed, T3420K must be at V/L 1.3.
- T3420I - Message AI0307. Optional EC (ECA 066) may be needed.
- T3420W - Dropping ready problems. If running on a 303X processor, disable the high speed buffer and rerun.

3420 OLT SENSE SWITCH INSTRUCTIONS

The 3420 OLT sense switches are turned on and off via the EXT= portion of the DEV/TEST/OPT/command in OLT(s)EP. The following example illustrates turning on sense switches 0, 5, 9 and W.

```
//EXT=059W/
```

Notice that there are no commas in the above example. Commas are used to separate sense switches from EXT options and EXT options and EXT options from each other. To turn off sense switches enter

```
//EXT=/  
or  
//EXT=9W/ if you wish to leave 9 and W on.
```

3420 OLT SENSE SWITCH REFERENCE

<u>SWITCH</u>	<u>FUNCTION</u>	<u>USING SECTIONS</u>
0	Run alternate density	F,R
1	Run 7-TK drives at 556 BPI	R
2	Run 7-TK RPQ drives at 200 BPI	R
3	Reserved	
4	Reserved	
5	Go down times multiplied by 20	R
6	Bypass motions in routine 1	S
7	Go down times multiplied by 20	S
8	Print all data compare errors	S
9	Execute test	L
W	Run test in read only mode	A,B,C,D,E,F,G,H,I,J, K,L,M,N,O,P,Q,R,S,T, U,V,W,X,Y,Z
Z	Run test in 6250 mode	A,B,C,D,E,F,G,H,I,J, K,L,M,N,O,P,Q,R,S,T, U,V,W,X,Y,Z

3420 OLT EXT=OPTION INSTRUCTIONS

EXT options are a way of communicating information to an OLT for the purpose of controlling the manner in which a test proceeds. EXT options differ from sense switches in that the CE may provide variable information to the diagnostic or a more descriptive term may be used (ex. EOT vs. sense switch 4 to cause testing to go to end of tape).

EXT options are set at DEV/TEST/OPTION time. The following entry will cause test T3420Q to be run on device 180. Testing will continue to end of tape with record lengths of 9000 bytes.

```
180/3420Q/EXT=EOT,QRECL=9000/
```

The format of the EXT option at device/test/option time is

```
EXT=SS,OPT,OPT.....
```

SS is a positional parameter and is for entering whatever sense switches are desired for the test. OPT represents ext options from the preceding list. Since SS is a positional parameter, a comma must immediately follow the equals sign if only EXT options are to be set. Each option in the list must be separated from the others by commas.

Note - If EXT is to be used, it must be the last entry in the OPT field of the DEV/TEST/OPT reply.

For a more complete discussion of each of the 3420 ext options, see the individual section write ups in the 3420 OLT Diagnostic Users Guide.

3420 OLT EXT=OPTION REFERENCE

OPTION	FUNCTION	USING SECTIONS
EOT	Run test to end of tape	F,Q,R,X
ERPT	Error Print	AB
EXCP	Expand device selection	AB
GDP	Pass count for routine 3	S
GDT	Specify go down time for test	R,S
L	Increase gap size specification	W
LWR	Run test in LWR mode	AB
NEPT	No error print	AB
NEXC	No device expansion	AB
NLWR	Run test in normal write mode	AB
P2	Expanded print option	E,Q,T,U,X,BA,BB
P3	Expanded error print option	E,Q,T,BA,BB
QRECL	Specify record lengths for test	Q
RECL	Specify record lengths for test	R
SNS	Enter sense bytes for analysis	A,WR
WRECL	Specify record length for test	W

CAUTION The use of EXT=,EOT can cause a diagnostic run time of several hours.

3420/3803 REFERENCE GUIDE

General Form

Examples

Testing Loop Choices:
 (NTL NO TEST LOOP)
 (TL(count) TEST LOOP)

NTL
 TL(25)

Error Loop Choices:
 (NEL NO ERROR LOOP)
 (EL ERROR LOOP)

NEL
 EL(1)(25)

Error Print Choices:
 (NEP NO ERROR PRINT)
 (EP ERROR PRINT)

NEP
 EP

Control Print Choices:
 (NCP NO CONTROL PRINT)
 (CP CONTROL PRINT)

NCP
 CP

Parallel Printer Choices:
 (NPP NO PARALLEL PRINTER)
 (PP (level) PARALLEL PRINTER)

NPP
 PP(3)

Print Choices:
 (NPR NO PRINT CHOICE)
 (PR PRINT CHOICE)

NPR
 PR

First Error Choices:
 (NFE NO FIRST ERROR)
 (FE FIRST ERROR)

NFE
 FE

Manual Intervention Choices:
 (NMI NO MANUAL INTERVENTION)
 (MI MANUAL INTERVENTION)

NMI
 MI

Spurious Interrupt Choices:
 (NSI NO SPURIOUS INTERRUPT)
 (SI SPURIOUS INTERRUPT)

NSI
 SI

Remote FE Choices:
 (NRF NO REMOTE)
 (RE REMOTE)

NRE
 RE

Trace Choices:
 (NTR NO RETURN CODE)
 (TR RETURN CODE)

NTR
 TR

EXT choice:
 EXT=data

EXT=012 wxyz
 EXT=,P1
 EXT=,P2
 EXT=,P3
 EXT=,EOT
 EXT=012 wxyz,
 P1,P2,etc.

- (TL) means recycle test run currently specified for the number of times indicated by count. If no count is specified, 10 is the default value. Terminate the loop by pressing the "ATTENTION" or "REQUEST" key on the console and replying to message SEP105D with 201, //NTL/. The count for a Testing Loop may range from 1 through 32767.
- (EL) Loops as close as possible on a section of code (controlled by the program) that is causing the first error encountered. EL(1) causes indefinite loop. EL (count) allows a finite number of repetitions. Terminate the error loop by pressing the "ATTENTION" or "REQUEST" key on the console and replying to message SEP105D with 201, //NEL/. An indefinite Testing Loop or any Error Loop is stopped by the operator's intervening and re-entering the loop option as NTL or NEL.
- (EP) Prints diagnostic error message from test sections.
- (CP) Prints test section "start" and "termination" messages.
- (PP) Produces test section output messages on console device in addition to the message output device. In the Parallel Printer option, specify level as: 0 for header only; 1 for header, description, and messages; 2 for header and results (in hexadecimal); and 3 for all information. Reference numbers are included only when 1 or 3 is selected. IN NPP, none of these are printed.
- (PR) Prints DPRINT messages from the unit test.
- (FE) Produces a special first error message and a communication interval when the first error in a test section is found.
- (MI) Allows routines to be run which require manual intervention.
- (SI) Prints spurious interrupts.
- (RE) Indicates to OLTSEP that the remote FE specialist is in control and that he will respond to Immediate Reply messages.
- (TR) In the TR option the OLT macro return code is printed.
- (EXT) Passes any information (up to 54 characters) following this entry to the test section. This option must be last in the OPT field. This information is used for setting sense switches and/or other options.

EXT can be cleared by EXT=//.

Either sense switches or a comma (,) must be entered in the EXT= field as the first parameter (i.e., EXT=,P1). Sense switches are a positional parameter.

If EXT is chosen, it must be specified last and its data

must not contain a slash. The discussion of a routine indicates when EXT is supported by that routine and describes responses that are valid.

Note: Not all options are supported by all monitors. If in trouble, use the PROMPT function.

3420/3803 ONLINE TESTS

SECTION RO-WR ERROR ANALYSIS

These two OLTs apply to the 3803-2 only. The MAPs and the OLTs are designed as an integrated package. You should start with the MAPs and run the OLTs as indicated when analyzing an error.

All of the 3803/3420 OLTs diagnostics can save the error sense data for later analysis by OLT 3420RO and OLT 3420WR. The error sense data "save" field is a common area for all of the 3803-3420 OLTs. Therefore, if more than one OLT is run and has errors, the sense data from the last error in the last OLT run is available for analysis.

Although the sense data is saved for an error in all of the OLTs, only OLTs A-G, P, Q, R, and S are recommended for FRU analysis. The sense data from the other OLTs can be analyzed, but the results may be misleading. This is due to errors that are forced by the OLTs.

OLT WR has an EXT= option whereby sense data to be analyzed can be entered from the keyboard.

Example: DEV/3420WR/EXT=,SNS=804400
8000002C000008000000C7/

At least the first fourteen bytes (0-13) should be entered. The extent field (EXT=) however, will not permit entry of all 24 bytes.

HOW TO GENERATE A "PREWRITTEN" OR "READ ONLY" TAPE

In the MAPs, you will note references to a "Read Only" tape. (In several sections of the User's Guide, you will note references to a "prewritten tape". The terms "prewritten" and "read only" are synonymous.) This tape is a diagnostic tool which should be generated when the system is operating correctly. You should have a "Read Only" tape generated in 6250 bpi available for analyzing failures. Sense switch Z which is in OLTs routines A-G generates "Read Only" data in 6250 bpi.

Note: When changing the EXT= parameter, the program must always be called:

Example: DEV/3420A-G/EXT=Z/
Example: /3420A-Z/EXT=WZ/
not //EXT=Z/.

3420/3803 ONLINE TESTS (CONT'D)

To generate a "Read Only" tape (6250 bpi), the OLTs A-G are run with first error option and sense switch Z on.

Example: DEV/3420A-G/FE,EXT=Z/.

When the "Read Only" tape has been generated without any errors, the tape should be file protected.

FALSE CREASE TAPE ERROR - OLT

OLT	Messages
T3420I	AI0108
T3420L	AI0137
T3420K	AK0106
T3420M	AM0108

Byte 17 (EC) should be plugged as follows: (3803 logic page AA004)
Prior to EC733843 bit 6 and 7 should be 01
After EC733843 bit 6 and 7 should be 10
After EC734866 bit 6 and 7 should be 11
R060 OLTs reversed test I and M.
If byte 17 is plugged incorrectly, the wrong routine will be run.
This is for a 3803 Mod 001 only. A 3803 Mod 002 will be plugged for bit 6 and 7 = 01.

STRESS TAPE P/N 1848621

A prewritten tape used for diagnosing the operating parameters of the 3803 Mod 2 has been generated by a unique machine for this purpose and cannot be created or duplicated by any other known method. This tape is used in conjunction with OLT diagnostic T3420BA and T3420BB (stress tape 1 and stress tape 2) and should be ordered from the nearest EPC just prior to converting a 3803 model 1 to a model 2. Reference OLT User's Guide dated March 1974 or later for explanation of tests etc. As recertification of the stressed data is not possible, care must be exercised so as not to damage the tape. A damaged tape will have to be replaced with a new one.

3420/3803 REFERENCE GUIDE

3803/3420 DC POWER SUPPLY CHECKS AND ADJUSTMENTS

REFER TO MLM 08-570

3420 POWER NTF CHECKLIST

- o Check that air filter is clean and blower is running smoothly.
- o Check/adjust DC voltages (watch for excessive ripple).
- o Check for loose power supply screws if problem is recurring.
- o Check air flow mercury switch for correct operation.

3420 POWER SERVICE TECHNIQUES

- o When checking DC voltages use all standard safety precautions. The +6 Vdc should be adjusted with the 3420 in write status, ready, away from load point, and moving tape.

3420 POWER CHECK, NO FILE PROTECT OR POWER RELATED PROBLEMS

- o Refer to MLM 00-058. With power type problems, it is a good idea to go over the supplies checking for loose screws, fuse holders, cable connectors, etc. Check supply levels. Vibration may help aggravate failures.

3803 FAILURES

- o Highly intermittent failures can be caused by the -4Volt power out of tolerance. Tolerance must be -4volt \pm .01 and ripple less than 80 mv PP MLM-08-570.



COMMON ABENDS
REFERENCE MLM 00-035

Abnormal Ending (ABEND)

II. ABEND Codes

- A. The message and codes section of the appropriate software users manual contains a numerical listing of the ABENDs. The message number, IECXXX, is followed by the ABEND code (CCC-RC), and then job related information. An explanation of the major code is given, followed by a list of return codes and an explanation of each code.
- B. For tape operations, the failures fall generally into two categories; open MACRO (ABEND 413-613) and close MACRO (ABEND 137-214-237-637-714).

I. Open/Close/EOV

- A. Every tape operation uses one or more sets of instructions (MACROS) to identify, verify, and when necessary, update information fields on the tape volume. These fields are the header label and trailer label, consisting of two or more records and one or more tape marks.
- B. The MACROS (open/close) consist of tape read/write and positioning commands which result in a number of "turnaround" operations.
- C. The nature of these turnaround operations, in addition to reading and writing short (80 character) records and tape marks, results in a probability of some form of failure. The two most common failures are (1) I/O errors and (2) positioning errors. The latter exists if missing (spacing over) a record or a tape mark causes subsequent commands to read a record, reach load point or a tape mark when not expected.
- D. One other type of error which results in a failure detected at "close" time is either picking or dropping a data record which results in a mismatch between the number of records transferred and the count posted in a trailer record when the tape was written.
(block count errors)

In general, it has been found that if temporary read/write failures are reduced, retry or error recovery is reduced, thereby minimizing the possibility of producing a system ABEND.

ABENDs Theory

ABEND 137, 237, 413, 613, and 637 may be caused by missing tape marks. Missing tape marks are caused by:

- o Incorrect forward-backward ratio.
- o Loss of signal amplitude causing a failure to recognize the tape mark.
- o Excessive crosstalk, indicating that data is fed into a dead zone. Data recorded on any track in a dead zone will prevent reading a tape mark correctly.

To check for loss of amplitude and crosstalk, use the failing drive and tape. Find the tapemark on the tape that was not read correctly. Cycle back and forth across the failing tape mark with the CE panel. Sync on Go Forward (T-A1F2J10) and scope all tracks (read card test points) and ensure that the signal is good on all tracks in zones 1 and 2 (tracks P,0,5 and 2,6,7).

Measure the amplitude on tracks 1,3 and 4 (zone 3) and ensure that there is less than 140 mv of signal (models 4,6, and 8 only).

Crosstalk is caused by:

- o Defective write card.
- o Defective read card.
- o Defective R/W head.
- o Poor tracking. If tracking is out of specifications, go to Capstan Dynamic Alignment (see 08-150). The drive that wrote or read the tape, or both, could cause crosstalk.

If the failing tape is not available, write a tape on a working tape drive offline, and use that tape to check for crosstalk on the suspected failing drive.

137/637 ABEND

Machine Type	Possible Causes
3803	Defective 01A-A2N2 card
3803	Defective 01A-B2F2

237 ABEND

Machine	Possible Causes
3420	Large tape creases detected as gaps (check stubby bar clearance).
3420	Short records (80 characters) falling within a tape crease.
3420	Tape edge damage.
3420	ECA097 E/C 443935 (6250)—Fix for short gap during backspace after a write error caused by erratic tape motion, not installed.
3420	R/W head forward-to-backward ratio is out of specifications.
3420	Tape sticking.
3420	Dirty capstan.
3803	Missing Suppress Out, intermittently breaking channel/command word (CCW) chain, updating the count but not losing a record.
3803	Defective 01A-B3F2 inbound tag card XC700.
3803	ECA079—Unexpected interrupt with status = "00" from a non-two channel switch machine in multiple CPU and 2X, 3X, or 4X switch installation.

413 ABEND

Machine	Possible Causes
3420	Defective T-A1C2 MST card.
3420	ECA086 EC 443890 - improve reliability of the autocleaner.
3420	Defective A1H2
3420	Defective T-A1L2
3420 MODS 4,6, 8	ECA073 E/C 735817 - delay ready, after rewind, to allow autocleaner to return.
3420	Damaged tape at load point.
3420	Contamination on the Read/Write head, or the capstan is glazed.
3803	Defective 01A-A2D2 MST card or defective 01A-A2E2 MST card.
3803	Broken CCW chain without Unit Check. Run an I/O software trace for more problem definition.
3803	ECA079 - Prevent busy in middle of CCW chain, not installed.

3420/3803 REFERENCE GUIDE

613 ABEND

Machine	Possible Causes
3420	ECA097 E/C 443935 - short gap engineering change not installed.
3420 MODS 4,6,8	ECA073-Delay Ready, after rewind, to allow autocleaner to return.
3420	Contaminated Read/Write head.
3420	Damaged tape at or near load point.
3420	Read/Write head forward-to-backward ratio not in specifications.
3803	Defective 01A-A2N2 card, extra tape mark.
	Defective 3168/2880 card, high-speed buffer - data compare.
OS/VS2 R017	PTF 70751 not installed.
3803-1	Tape Tracking leaves a faint TM (where existing files are updated) because of the overwriting of the old EOF TM. In this case, the writeheads actually do the erasing of the old TM.
3803-1	Defective 01A-B2F2
3803	Incorrect UCW Plugging

Compatibility problems between drives can be caused by capstan tracking out of adjustment. If this adjustment is OK, then bit positioning may be the cause of the incompatibility. Refer to page 5.3 for bit positioning and capstan tracking checks.



REEL MOTOR AND REEL MOTOR BOARD PART NUMBER COMBINATIONS

POWER SUPPLY	REEL MOTOR	REEL BOARD
<u>MODEL 3, 5, 7</u>		
2522840 60HZ		
2515413 60HZ**	2515228 LEFT	
2515421 60HZ**	2513168 LEFT	373561
2522839 50HZ		4450016 [B]
2524645 50HZ**		
1766046 50HZ**	1765047 LEFT	
	2523744 RIGHT	2524137
	2523744 LEFT. [A]	4450016 [B]
<u>MODEL 4, 6, 8</u>		
1767836 60HZ		
1767917 60HZ**		
1767835 50HZ		
1767918 50HZ**		
<u>MODEL 3, 5</u>		
2522838 60HZ		
2515367 60HZ**		
2515410 60HZ**	2513165 LEFT	
2522837 50HZ	1765389 LEFT	
2524644 50HZ**	1765390 LEFT [A]	373065
1766045 50HZ**	2513074 RIGHT	4450015
	1765390 RIGHT	
<u>MODEL 4, 6</u>		
1767834 60HZ		
1767850 60HZ**		
1767833 50HZ		
1767849 50HZ**		
NOTE [A] WTC MANUFACTURED		
NOTE [B] JUMPER WIRE ON REEL MOTOR BOARD MUST BE PLUGGED TO THE CORRECT POSITION FOR THE TYPE OF REEL MOTOR USED. SEE LABEL ON REEL MOTOR BOARD FOR INSTRUCTIONS.		
** 90K S/N DRIVES INCLUDE S/N 90,000 TO 99,999 AND CANADIAN DRIVES S/N 43,001 TO 43,084 AND 45,000 TO 45,054		

3420/3803 REFERENCE GUIDE

PNEUMATIC SUPPLY ASSEMBLY

E/C 847202

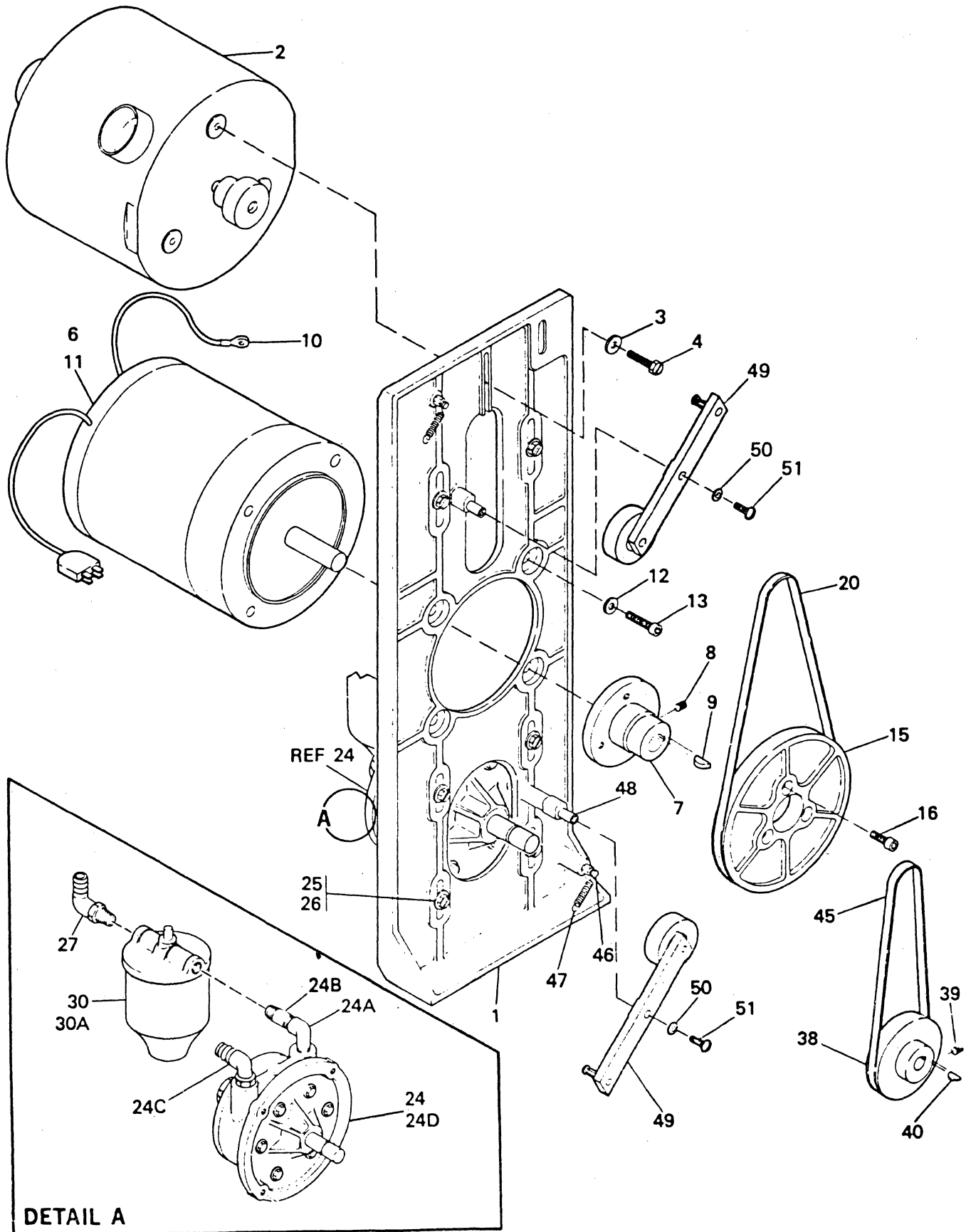

3420/3803 REFERENCE GUIDE

LIST AND ITEM NO.	PART NUMBER	QTY	DESCRIPTION	NOTE
			NOTE A USED ON MOD 4	
			NOTE B USED ON MOD 6	
			NOTE C USED ON MOD 8	
			NOTE D USED ON 60HZ	
			NOTE E USED ON 50HZ	
21 -	8492827		SUPPLY ASM, PNEUMATIC (MOD 4/6/60HZ)	
-	8492829		SUPPLY ASM, PNEUMATIC (MOD 4/6/50HZ)	
-	8492837		SUPPLY ASM, PNEUMATIC (MOD 8/60HZ)	
-	8492835		SUPPLY ASM, PNEUMATIC (MOD 8/50HZ) FOR NEXT HIGHER ASM SEE FIG. 5	
- 1	8492824	(1)	• CASTING, PNEUMATIC SUPPLY	
- 2	8492819	(1)	• BLOWER, VACUUM	A,B
- 2	8492818	(1)	• BLOWER, VACUUM	C
- 3	140777	(3)	• WASHER, PLN .257 ID X .750 OD X .094 THK	
- 4	234344	(3)	• SCREW & WSR, HEX HD .250-20 X 1.000 LG	
- 6	8492822	(1)	• MOTOR ASM.	A,B
- 6	8492823	(1)	• MOTOR ASM:	C
- 7	NR	(1)	• • HUB	
- 8	NR	(1)	• • SETSCREW	
- 9	NR	(1)	• • KEY	
- 10	359695	(2)	• • TERMINAL	
- 11	NR	(1)	• • MOTOR	
- 12	101998	(4)	• WASHER, PLN .252 ID X .625 OD X .094 THK	C
- 13	146327	(4)	• SCREW, HEX SOC HD .375-16 X .750 LG.	A,B
- 13	149908	(4)	• SCREW, HEX SOC HD .250-20 X 1.000	C
- 15	8492810	(1)	• PULLEY (60HZ/BELOW 4000 ALTITUDE)	D
- 15	8492814	(1)	• PULLEY (60HZ/ABOVE 4000 ALTITUDE)	D
- 15	4450030	(1)	• PULLEY (50HZ/BELOW 4000 ALTITUDE)	E
- 15	4450026	(1)	• PULLEY (50HZ/ABOVE 4000 ALTITUDE)	E
- 16	317464	(3)	• SCREW, HEX SOC HD .250-20 X .625 LG	
- 20	8492977	(1)	• BELT, FLAT (60HZ/BELOW 4000 ALTITUDE).	D
- 20	2496287	(1)	• BELT, FLAT (60HZ/ABOVE 4000 ALTITUDE)	D
- 20	8492976	(1)	• BELT, FLAT (50HZ/BELOW 4000 ALTITUDE).	E
- 20	4450028	(1)	• BELT, FLAT (50HZ/ABOVE 4000 ALTITUDE)	E
- 24	4947523	(1)	• COMPRESSOR, ASM	
- 24A	1765065	(1)	• • ELBOW, PIPE .375-18 NPT	
- 24B	1765059	(1)	• • PIPE, 375-18 X 1.50 LG	
- 24C	2522880	(1)	• • ELBOW, HOSE .658 OD X .35 ID	
- 24D	2515538	(1)	• • COMPRESSOR	
- 25	234344	(4)	• SCREW & WSR, HEX HD .250-20 X 1.000 LG	
- 26	140777	(4)	• WASHER, PLN .257 ID X .750 OD X .094 THK	
- 27	2522880	(1)	• ELBOW, HOSE	
- 30	1765653	(1)	• FILTER ASM, INLET (PUROLATOR) INTERCHANGEABLE WITH CUNO TYPE	
- 30	1765057	(1)	• FILTER ASM, INLET (CUNO) INTERCHANGEABLE WITH PUROLATOR TYPE	
- 30A	1765654	(1)	• • ELEMENT, FILTER (PUROLATOR)	
- 30A	1765058	(1)	• • ELEMENT, FILTER (CUNO)	
- 38	8492820	(1)	• PULLEY	D
- 38	8492805	(1)	• PULLEY	E
- 39	2522905	(1)	• SETSCREW, HEX SOC .250-20 X .250 LG	
- 40	12015	(1)	• KEY	
- 45	8492838	(1)	• BELT, FLAT 20.00 LG	
- 46	2496296	(2)	• STANDOFF, SPRING	
- 47	2496300	(2)	• SPRING	
- 48	2496272	(2)	• POST, PIVOT	
- 49	8493010	(2)	• IDLER ARM ASM	
- 50	9092	(2)	• LOCKWASHER, SPLIT .194 ID X .337 OD	
- 51	332620	(2)	• SCREW, BIND HD 10-32 X .500 LG	

END OF ASSEMBLY

3420 PM KITS

Left Vacuum Column Switch Kits

B/M 4450063

Checkpoint--Left switch plate with 5 holes and 5 switches (a group of 3 switches at the top and 2 at the bottom).

B/M 4469279

Checkpoint--Left switch plate all configurations (except those described).

Right Vacuum Column Switch Kits

B/M 4450062

Checkpoint--Right switch plate with 5 holes and 5 switches (a group of 2 switches at the top and 3 at the bottom).

B/M 4469278

Checkpoint--Right switch plate with 7 holes.

B/M 4469385

Checkpoint--Right switch plate with 5 holes (1 at the top, 3 at the center and 1 at the bottom).

Transport Switch Kits

B/M 4469380 -- MOD 3,5,7

B/M 4469381 -- MOD 4,6,8

Tubing Kits

B/M 4416409 -- Vacuum Tubing

B/M 4416408 -- Pressure Tubing

12 Month PM Parts Replacement B/M

B/M 8492273 -- Purolator) Includes input filter, tape cleaner
B/M 8492274 -- CUNO) block, and air bearing decorative
) covers.

B/M 1848717 -- Glass Bead Replacement Tape

3420 Vacuum Switch Part Numbers

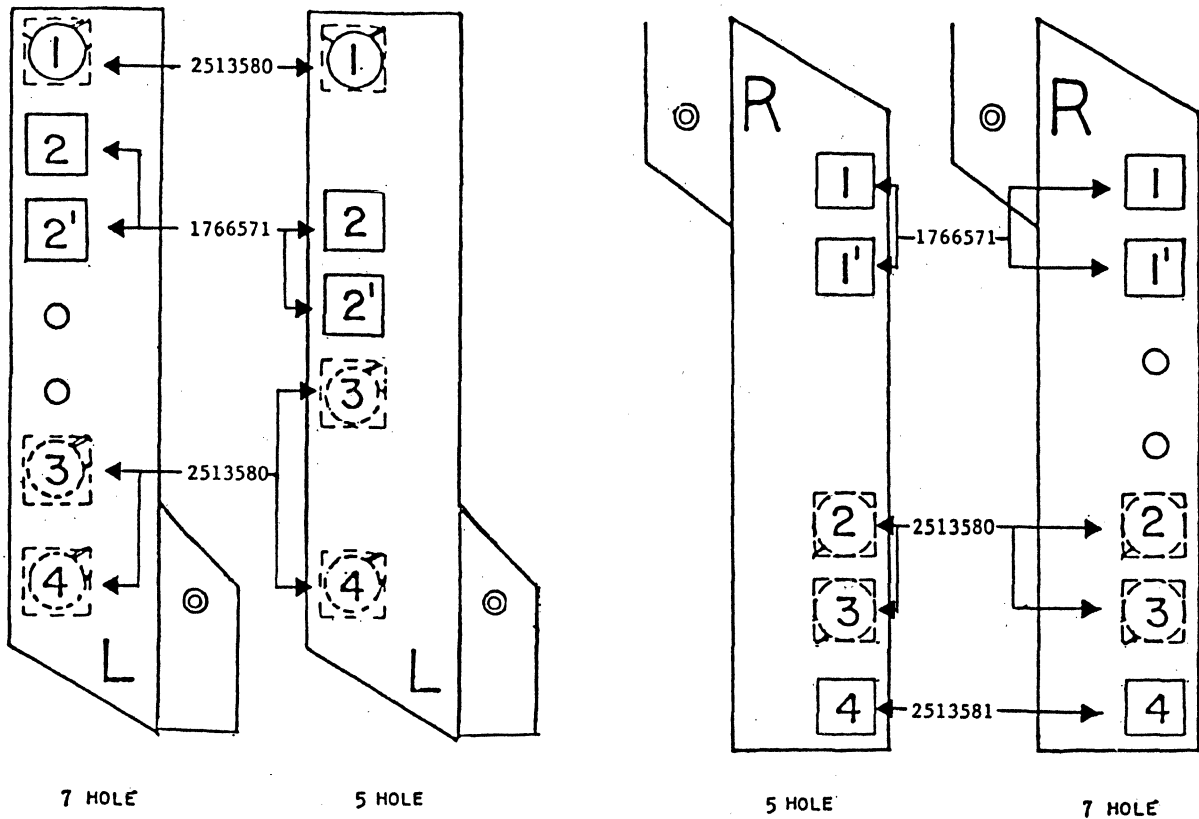

The above vacuum switch configurations will exist in all tape drives after the left and right vacuum switch PM Kits have been installed.

Use checkpoints on Page 14.4 to determine which B/M is necessary for your machine.

Note: If multiple switch failures occur or five (5) years has lapsed from the time initial installation was made, then B/M 4450062 (left column) or B/M 4450063 (right column) will be the ONLY Switch Kits required for replacement.

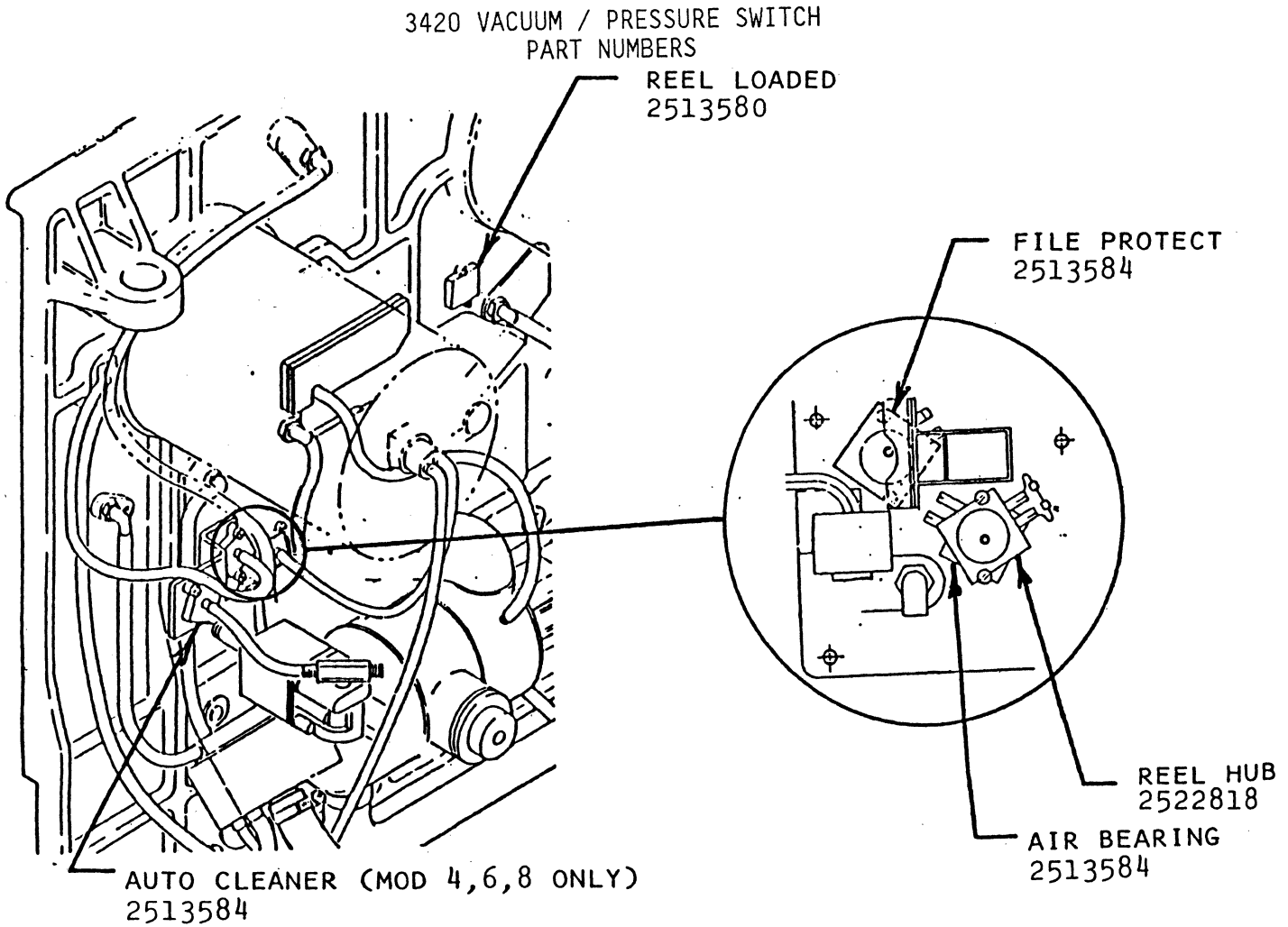

Note: The switches illustrated above are available as a transport switch PM kit. (Refer to page 14.4).

GROMMET PART NUMBERS

Upper Belt Access Cover	Lower Belt Access Cover
P/N 853045 Grommet	P/N 2180733 Grommet
P/N 853044 Plunger	P/N 2178597 Plunger
Logic Gate Cover	Resistor Cover
P/N 2180733 Grommet	P/N 657717 Grommet
P/N 2178597 Plunger	P/N 2178597 Plunger
Reel, Capstan Board	
P/N 853045 Grommet	
P/N 853044 Plunger	

COMMON 3420 PART NUMBERS

Capstan Motors

<u>Part Number</u>	<u>Model</u>
1766960	3,5,7 (9XXXX series)
1766761	4,6
1846689	4,6 (9XXXX series)
1766700	8
1845857	8 (9XXXX series)
2522864	3,5,7

Transfer Valve - Three-Way Valve and Manifold Assemblies (after EC 847202 ECA 117)

Valve & Manifold Asm P/N	Model
1845513	3,4,5,6,7
1845512	8

3420

Piggy-back Supply - Box Series (9XXXX Serial Numbers) and 34090 to 37099

Pre-regulator - P/N 4169370 (was 1767871)



3420/3803 REFERENCE GUIDE

TOOLS & TEST EQUIPMENT

Tools and Test equipment required to properly service 3420 magnetic tape units and 3803 tape control units are listed in 3803-2/3420 MLM 80-000 or 3803-1/3420 MLM 20-000.

Additional Tools

<u>Part</u>	<u>Name</u>
4298806	Reference/skew plate replacement tool kit (refer to 3420 service aid 9 and 3420 service aid 10). This is a regional tool.
453608	Mechanical skew adjusting wrench
2515222	Replacement reel hub alignment tool gauge
8493001	Tape transport cleaner
1765623	Replacement 3420 tester cable
8496278	8060A digital meter (Fluke)



3803 MODEL 1 DATA FLOW

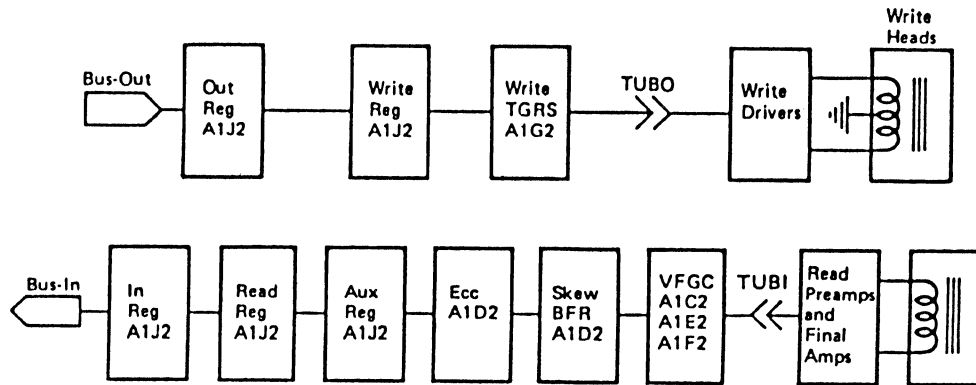

VFCG ZN1	A1C2*	BITS P-0-5
VFCG ZN2	A1E2*	BITS 2-6-7
VFCG ZN3	A1F2*	BITS 1-3-4

* = Interchangeable cards
see notes 3803-1/3420
MLM 19-023

3803 MODEL 2 DATA FLOW

See MLM 50-XXX for more detail.

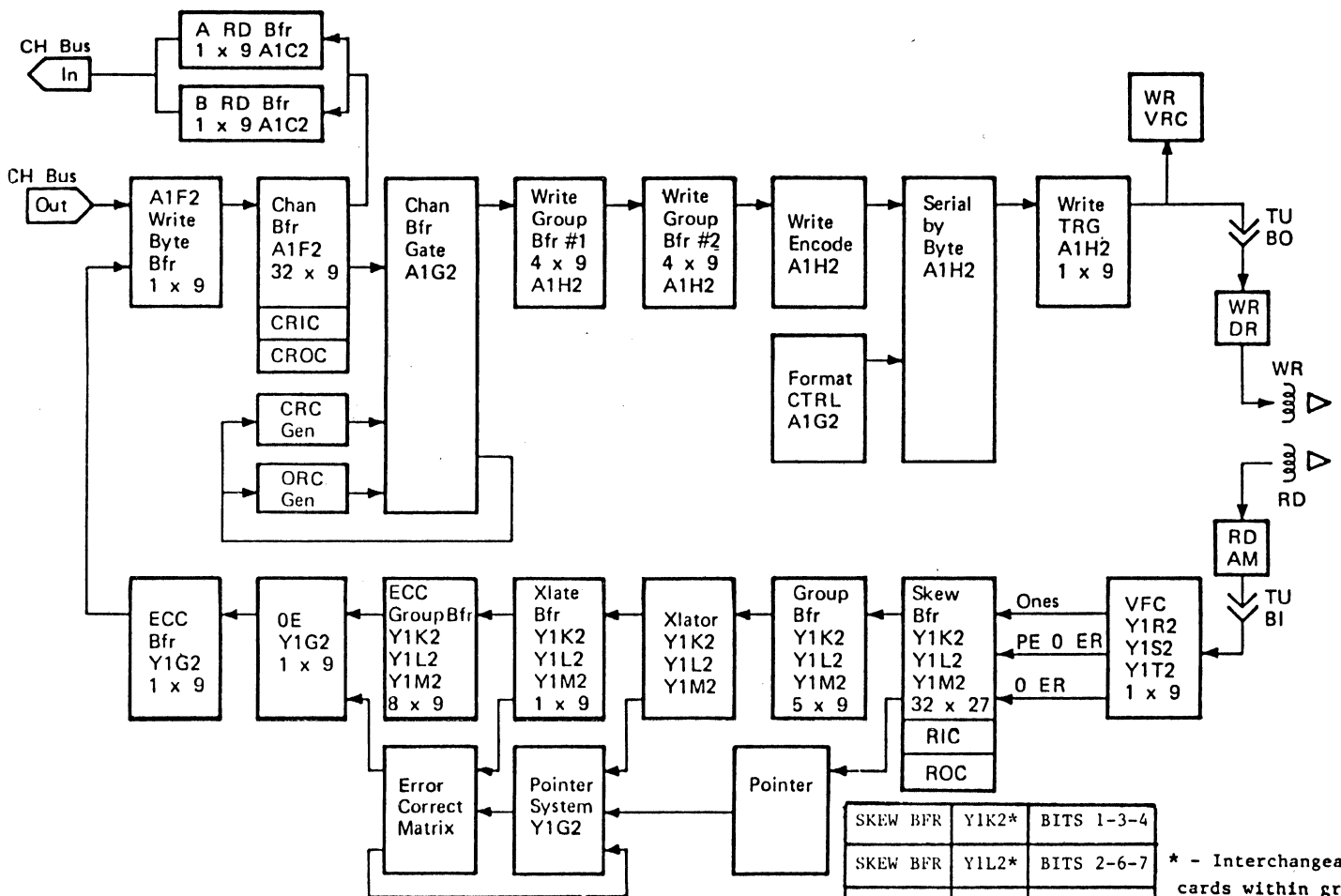

SKEW BFR	Y1K2*	BITS 1-3-4
SKEW BFR	Y1L2*	BITS 2-6-7
SKEW BFR	Y1M2*	BITS P-0-5
VFC ZN3	Y1R2*	BITS 1-3-4
VFC ZN2	Y1S2*	BITS 2-6-7
VFC ZN1	Y1T2*	BITS P-0-5

* - Interchangeable cards within group

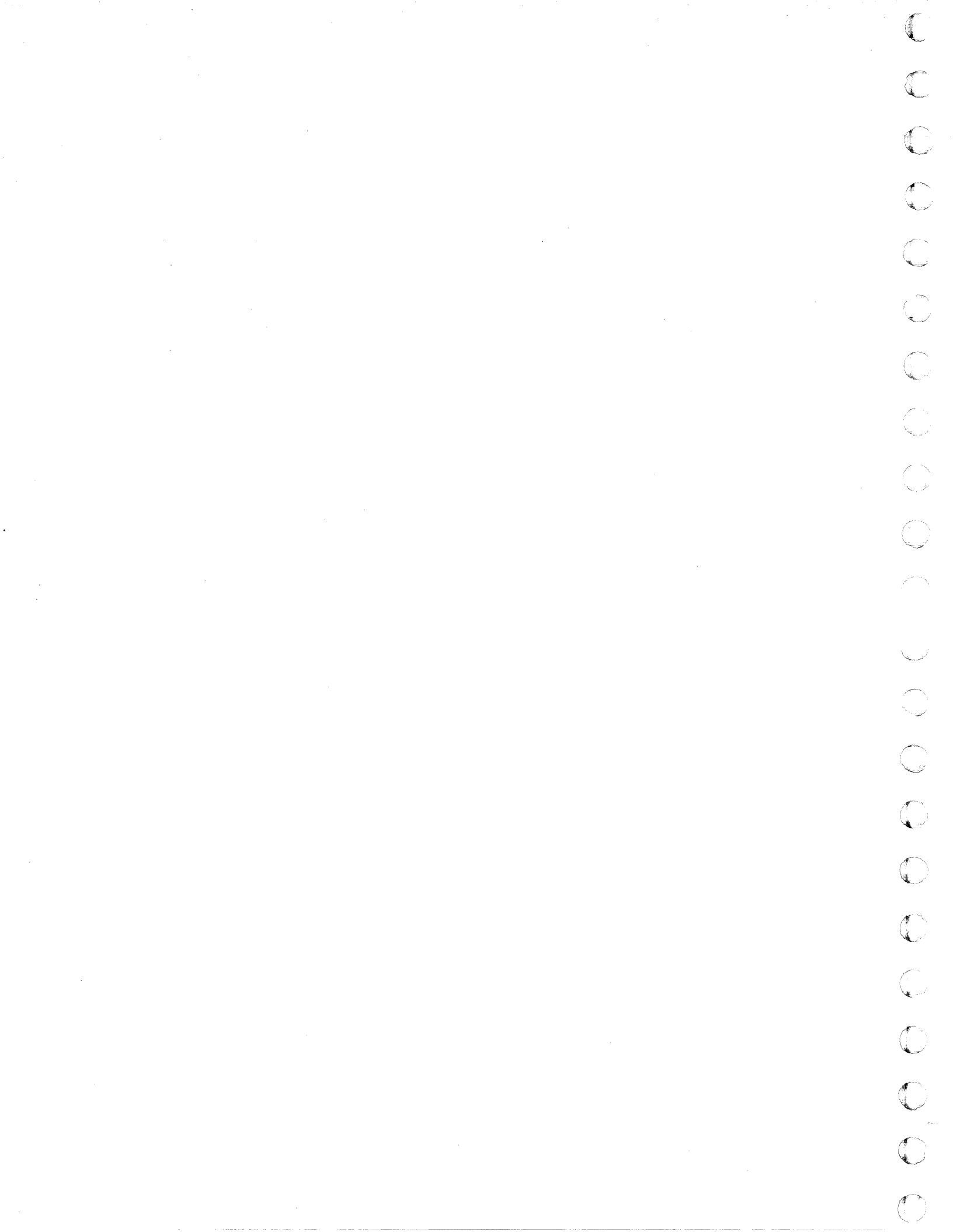

3803-2 MICROPROCESSOR TIPS

General Reference Information

The following items should be kept in mind when troubleshooting a (microprocessor) problem:

- o The COMPARE EQUAL line (A1U2U07) goes minus just before the execution of the instruction. The stop-on switches must be OFF to allow a compare.

If the failure is at address 000, RESET or TRAP ALU2 (A2K2D10, AA011) is a good sync point.

- o When displaying ALU execution on the scope, make sure that a complete cycle is shown. The "0" ns taps for the ALU are:
ALU1 B2F2G12
ALU2 A2K2G12
- o BU, BOC, and ADD instructions require a long cycle, 200 ns. All other instructions execute in a short cycle, 150 ns.
- o Slow fall time of a pulse might be caused by a missing external load. Check the tape control ALDs for their locations.
- o Always remember that you are troubleshooting lines as well as cards. If you find a bad net and the card or cards driving the line have been ruled out, something else must be wrong within the net.
- o If an I/O command is involved in troubleshooting a problem offline, a contingent connection might occur. This condition is apparent if ALU1 stops with address 301 in the instruction counter. To break the connection, follow each failing command with a sense command.
- o Random ALU failures can be caused by the ALU (oscillator) card, A1H2.
- o Use the timing charts for a better understanding of an operation, as well as reference when a timing check is called for. Timing chart is on 16-001.
- o If cards are changed and the outputs are still bad with good inputs, check for proper voltages at the card socket.
- o The CE panel lights indicate the ROS data bits, not the ROS register bits.

See MLM 16-000 for more detail.

ALU ADDRESS STOPS

LOOK UP THE ALU ADDRESSES IN THE FOLLOWING CHART.

ALU-1	ALU-2	ERROR CONDITIONS	POSSIBLE FRU	*FIX*
002	002	POWER ON RESET	B2F2	
005	000	POWER ON RESET	B2F2	
005	000	HANGS	B2Q2-INTF A B2P2-INTFB	
014	000	UPG DETECTED ERR	A2P4	
027	000	D BUS PARITY	A1R2	
03F	000	HANG	A2P4	
05F	000	BOC	B2M2	
288	33F	TAPE RUNAWAY	A1Q2	
2A7	000	TIMEOUT	B2Q2	
2B7	000	RUNAWAY ON WRITE	A1G2	
301	000	LO-IC ON RESET	B2H2	
302	000	HANG	B2Q2	
303	000	UPG DETECTED ERR-HANG	A2H2-A2R2-B2N2	
396	000	UPG DETECTED ERR	A1J2-A2R2	
39F	007	HANG-IFCC	A2D2	
39F	1DF	CANNOT RESET	A2C3	
3AF	000	OFF LINE RESET	A2P4	
3BF	002	RUNAWAY ON WRITE	A1G2	
53C	000	BUC	B2M2	
569	000	FOLLOWING RESET	A1R2-B2F2	
7FF	1FF	UPG DETECTED ERR	A2L2	
7FF	5FF	D BUS PARITY	B2L2-A2L2	
2F4	000	HANGS	TAG INTERFACE CABLE	
3FF	1BF	HANG-NO RED LIGHTS	B2L2	
55D	5BF	HANGS	A2Q2	
7FF	600	HANGS	A2J2	
36A, 36B	301, 302	HANGS	B3J2	
302	000	RESET HANG	B2H2	
569	000	RESET HANG	B2H2	
320	---	HANG	A2L2-A2R2	
320	36B	HANG COMMAND CHAIN	B2Q2	
OFF	000	POWER ON RESET	B2K5	
7FF	5FF	RESET FAILS	A2N2 OR A2Q2	
568	5AF	IFCC, UPG DETECTED ERR	A1L2 IN DRIVE	
369	000	UPG DETECTED ERR	CABLE A2B5-B3Z1	
301	000	MTE, ENV	A1J2	
243	21F, 31F	HANG, UPG DETECTED ERR	A2P4	
303	000	T3420E AE0833 BSR	A1H2, A2H2, B2H2	
7FF	3FF	HANG	A2E2	
301	080	HANG ON RESET	B2C2	

3420/3803 REFERENCE GUIDE

ALU-1	ALU-2	ERROR CONDITIONS	POSSIBLE FRU *FIX*
305,307	000	ALU1 HANGS	A1R2
568	593		A2L2
567	5BF	HANG	A2T2
3FF	1FF	B BUS	A2H2
301	---	B BUS PARITY	B2L2
396	002	HANGS ON RESET	B2C2
07F	000	HANGS ON PWR RESET	B2E2
243	5D5		A1F2
5FF	5FF	D BUSS ERRORS	A2T2

MICROPROCESSOR CARD LOCATIONS

	MP1	MP2
ALU	B2C2	A2N2
ROS	B2H2	A2H2
ROS Reg	B2D2 B2E2	A2M2 A2L2
Clock	B2F2	A2K2
Instruction Decode	B2D2	A2M2
LSRs	B2C2	A2N2
Xout A	A2T2	A2Q2
Xout B	A2T2	A2Q2
D-Reg	B2C2	A2N2

Microprocessor Card Interchange List

The following is a list of cards that can be interchanged between ALUs:

ALU1	ALU2
B2J2	A2G2 (change program jumpers as shown on MLM 52-030 or MLM/PF 18-230)
B2C2	A2N2
B2D2	A2M2 (watch for program jumpers)
B2E2	A2L2
B2F2	A2K2

The following is a list of cards that can be interchanged if the two-channel switch feature is installed:

CAUTION: REMOVING THESE CARDS MAY CAUSE CHANNEL ERRORS,
EVEN WITH POWER OFF. PUT CPU IN SINGLE CYCLE
MODE BEFORE REMOVING CARDS.

B2Q2	B2P2
B2R2	B2S2

MICROPROGRAM EC's

Microprogram EC's are applied with two Array Patch Cards, type DE01, which provide auxiliary ROS arrays. The arrays contain four sets of microcode patches (ALU1 and 2 for 3803-1 and 2). Plug each card as shown in Figure 1 in order to select the proper patches for its location. The following patches are active when these two cards are installed (refer to MLM/PF 18-240 or MLM 52-102 for the patch listings:

	3803-1	3803-2
1. Alternative Path Device Busy	X	X
2. Velocity Retry Extension	X	X
3. Turnaround Delay	-	X
4. Allocated Busy	X	X
5. Truncated Postamble	-	X
6. Extra Device End	X	X
7. Sense Reset	-	X
8. Short Postamble	X	-

Verify factory plugging.

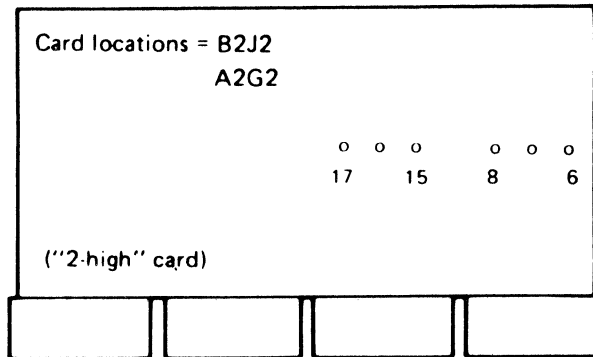

Note: If RPQ S10231 is installed see plugging instructions on MLM/PF 18-250 or MLM 52-103/104.

FIGURE 1

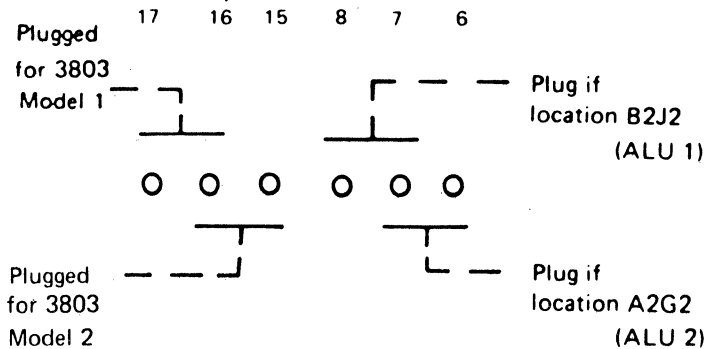



3803 CHANNEL INTERFACE

System/370 Disconnect In - MP Hardware Error

3803 In Idle Scans - ALU1 or ALU2 Error

1. Disconnect in raised after op-in on next channel initiated sequence.
2. ALU's trap and restart the idle-scan loop. The error is saved in ALU1 local storage.
3. Unit check is presented in initial status of next SIO/TIO if not a sense command.
4. Bus-out check is set at sense time if the control unit is holding ALU error and no other bit is on in sense byte 0.

3803 Connected to the Channel

ALU2 Error:

1. Unit check is presented in initial status of next SIO/TIO if other than a sense command.
2. Disconnect in will not be enabled.
3. Bus-out check will be set at sense time if no other bit is on in sense byte 0.

ALU1 Error: (W/O ALU2 Error)

1. Disconnect-in is raised and an interface control check results. (Channel issues selective reset).
2. Unit check is presented in initial status on next SIO/TIO if other than a sense command.
3. Bus-out check will be set at sense time if no other bit is on in sense byte 0.

Channel Errors Caused by "Disconnect-In" From 3803

3803-1,2 - Service Aid 5

The 3803 Models 1 and 2 present "disconnect-in" to the channel under either of the following two conditions provided "disconnect-in handling" is wired active (S/370-see Installation Manual).

1. Any time an error (sense byte 11) occurs in ALU1.
2. When an error (sense byte 12) occurs in ALU2 while ALU2 is in IDLESCAN.

Note: If an ALU2 error occurs while ALU2 is in other than IDLESCAN, equipment check is set and "disconnect-in" is not presented to the channel.

3803 CHANNEL INTERFACE

Generally, the "disconnect-in" will not result in a 3803 OBR being logged. Consequently, sense bytes 11 and 12 cannot be observed for the cause of the ALU error.

In order to determine the cause of the ALU errors not logged in an OBR, any of the following can be used depending upon your particular situation.

1. Enable the CE panel on the 3803 and activate "Stop on Control Check" switch. This will cause the 3803 to hard stop on the ALU error and you can see the cause in the CE panel lights. Set the ALU switch to ALU2 position first. If the customer experiences a "disconnect-in" error and you do not get a stop on the CE panel, set the switch to ALU1 and you should stop on the next hit.

Note: Be aware that using this method to locate the ALU error will cause the customer to experience a job abort and/or system hang instead of a probable recoverable error when the ALU error occurs.

2. Use MST CE indicator latch card P/N5851882 (see Tools and Test Equipment CEM 142) to monitor the individual ALU error bits. See 3803 Logic Pages AA461 and AB471.
3. When the 3803 brings up "disconnect-in", it also sets the bus-out check (byte 0, bit 2) and ALU hardware error (byte 4, bit 10) indicators on. These two bits are logged in the SDR counters as temporary errors.

We can therefore, temporarily - zap - the SDR software to assume that one of these two error counters is ready to overflow. This forces an OBR and allows observation of sense bytes 11 and 12. Either the "bus-out" or "ALU hardware" error can be used for the - zap -, however, the ALU hardware error bit is probably the best as errors other than ALU can cause bus-out checks. For assistance contact your PSR.

3803 CHANNEL INTERFACE (continued)

Holley Monitor Trap
3803 Model 1/2

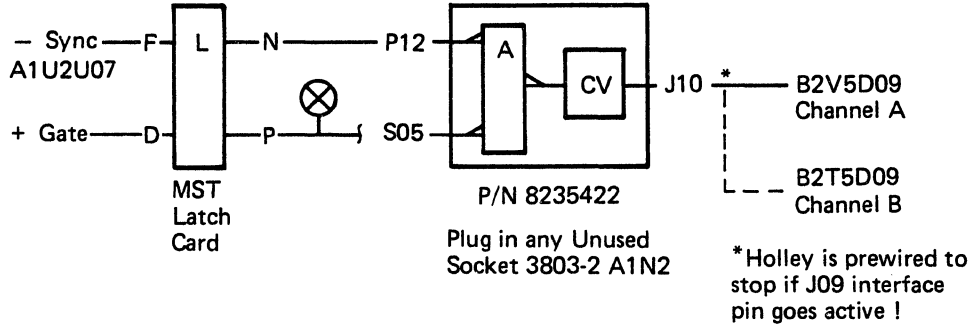

Use Tri-Leads for Backpanel

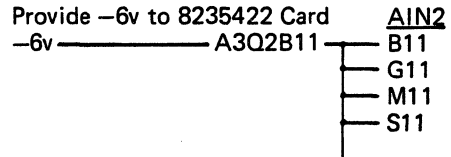

Stop Holley Recording on Sync



3420/3803 REFERENCE GUIDE

3420 ECA Listing

E/A

E = Essential

A = Required Change

ECA	EC	E/A	Description	Checkpoint	Machines Affected
001	733966	E	C-Test Exit	Check for an on/off line CE switch.	Mods 3,5,7
002	733999		OBSOLETE-REPLACED BY	ECA 112	
003	734021		OBSOLETE-REPLACED BY	ECA 112	
004	734030		OBSOLETE-RECORD	CONTROL ONLY	
005	734045	E	Prevent erasing tape with a +6 volt splash when loading tape. Route +6 Vdc to write driver card through R/W cable ferrite. (REA 24-22457).	Check for discrete wire routed through the R/W cable ferrite. Some machines may not have it routed this way. It is the wire from TB1-10 on logic gate and should go through ferrite.	Mods 3,5,7
006	733698		OBSOLETE-REPLACED BY	ECA 112	

3420/3803 REFERENCE GUIDE

ECA	EC	E/A	Description	Checkpoint	Machines Affected
007	734030B		OBSOLETE-REPLACED BY Prevent partial record when doing write after read sequence. Also prevents tape dump when going from low to high speed rewind. (Mod 3)	ECA 108	
008	734062 cancelled refer to 3420 service aid #8	A	Prevent tape damage. Prevent catch from popping out of lower restraint when using a cartridge.	Check the catch to ensure good retention.	A11
009	734063		OBSOLETE-REPLACED BY	ECA 024	
010	733704	E	WTC only replace paper capacitors C14 and C15 (to correct an REA problem) (50 Hz only) (REA 24-23866)	Check for disc-type caps C14 and C15 in the 50 Hz power supply	A11
011	734061		OBSOLETE		
012	734035		OBSOLETE REFER TO Prevent tape dump in right column during load.	08-800 MLM VACUUM COLUMN BALANCE	
013	734046		OBSOLETE-REPLACED BY Prevent tape dump in left column during load and also prevents tape damage due to tape hitting NRZI guides causing tape to twist in columns.	ECA 121	

3420/3803 REFERENCE GUIDE

ECA	EC	E/A	Description	Checkpoint	Machines Affected
014	734056		OBSOLETE-REPLACED BY	ECA 117	
015	734374		OBSOLETE-REPLACED BY	ECA 115	
016	734368		OBSOLETE-REPLACED BY	ECA 117	
017	734231		OBSOLETE-REPLACED BY R/C network installed across transfer valve solenoid relay to eliminate false load checks.	ECA 095	
018	734382		OBSOLETE-REPLACED PM KITS	BY VACUUM SWITCH	
019	734372		OBSOLETE-REPLACED BY	ECA 033	
020	734394		OBSOLETE-REPLACED BY	ECA 112	
021	734068	A	Correct PE write current for the P-burst and tape mark.	Check for P/N 8218291 at A1J2.	All W/O 7-Trk
022	734280		OBSOLETE-REPLACED BY	ECA 112	
023	734244	E/A	Changed heat sink in power supply manual status card.	Black jumpers from transistors to MSC board.	Optional Mods 3,5,7 Mandatory Mods 4,6,8

3420/3803 REFERENCE GUIDE

ECA	EC	E/A	Description	Checkpoint	Machines Affected
024	734392	E	High-speed rewind plunger (REA 24-23964) (replaced E009)	Check for an IBM-1 stamp on the 16-hole high-speed rewind plunger.	Mods 3, 5,7, B03, B05, B07
025	734395		OBSOLETE-REPLACED BY	ECA 117	
026	734391		OBSOLETE-REPLACED BY	ECA 121	
027	905864	-	World Trade Only	-----	----
028	734369	A	Install modified write driver card to prevent write and erase current splash on tape during a mid-tape load. (REAs 24-23889, 24-23874).	Check for EC 734369 stamped on the 9-track write driver or EC 734038 stamped on the 7-track write driver. Maintenance parts have this EC installed.	Mods 3, 5,7
029	734456	E	Safety: Eliminate power window pinch hazard during a thread and load operation	Check for 1000MF capacitor on power window board.	All
030	734467	E	Improve write reliability by adding a write enable relay to file protect circuit to carry the +6V write current to the write card.	Check for relay assembly close to the file protect pressure switch.	Mods 3, 5,7 B03 B05 B07
031	734468		OBSOLETE-REPLACED BY	ECA 124	
032	734743	-	OBSOLETE		----

3420/3803 REFERENCE GUIDE

ECA	EC	E/A	Description	Checkpoint	Machines Affected
033	734466	E	New reel latch, picks up ECA 019.	Ensure that the reel latch contains plastic rollers.	All
034	734469		OBSOLETE-		
035	905956	-	World Trade Only	-----	----
036	734288	E	50 Hz only. Prevents transfer valve solenoid from burning up.	Ensure that the solenoid drops when the pneumatic drops on a load check.	All
037	734504	E	Installs 15 amp fuse for F12 and F13 instead of 10A. Used for -48V in left and right reel motor.	Check for 15 amp fuse in F12 and F13.	Mods 3, 5,7
038	734483	E	Increase ampere rating for F12 and F13 to 15 amp 50/60 Hz.	Check for 15 amp fuse in F12 and F13.	Mods 3, 5,7, B03, B05, B07
039	734507 Cancelled composited with ECA 048.	E	Safety - Insulate -48V on interface boards P/N2515544, 2524666. (Picked up by E048).	Check for a clear or rubber coating over land pattern on power interface board for the modified power supply from J3-K to J5-B.	Mods 3, 5,7, B03, B05, B07
040	734506	E/A	Prevents burning relay contacts on reel motor boards.	Check for OV/UV card P/N 375478 and multiple sense card P/N 375451 or P/N 375469 in all power supplies.	Optional Mods 3,5 Mandatory Mod 7

3420/3803 REFERENCE GUIDE

ECA	EC	E/A	Description	Checkpoint	Machines Affected
041	734755		OBSOLETE-REPLACED BY	ECA 124	
042	734754	E	Capstan cover holder.	Check for holder inside power door.	All
043	734470	A	Improve read/write reliability on dual density 3420's.	Check for EC734470 stamped on dual density read cards.	Mods 3, 5,7
044	734762	E	High-speed rewind plunger shim P/N 1847100. Allows tape to clear read/write head on a thread or load operation.	Check for shim on mounting screw for HSR plunger.	Mods 3, 5,7 B03, B05, B07
045	734760	E	Eliminate multiple intermittent problems caused by noise generated from the select light.	Check for a 2-watt resistor located on wiring side of MST board from A1J2B04 to A1J2D08.	Mods 3, 5,7, B03, B05, B07
046	734741		CANCELLED		
047	734763		OBSOLETE-REPLACED BY	VACUUM SWITCH PM KITS	
048	734532	E	Solder the blade connectors on the power interface board to prevent intermittent problems.	Check for rivets soldered to the lands on back of the power interface board. (Modified power systems only).	All
049	734945	E	Reposition fiber optic lamp bracket to improve light output decreasing equipment checks.	Check for 45 degree bracket holding fiber optics lamp.	All

3420/3803 REFERENCE GUIDE

ECA	EC	E/A	Description	Checkpoint	Machines Affected
050	735881		OBSOLETE--REPLACED BY	ECA 112.	
051	734941		OBSOLETE		
052	735643	E	Provide metal clips to hold lower door glass.	Machines with vertical plastic retainers, as opposed to metal, holding lower glass in power door. Check for metal retainer under plastic held by second and fourth screws on each side.	All
053	734952		OBSOLETE COMPOSITED Modify the unload sequence to speed up the window down operation.	WITH ECA 121	
054	734953		OBSOLETE		
055	734956	A	Correct interference between the file protect pin and the file protect indicator pin on the tape reel.	Check for a recessed file protect plunger.	Mods 3, 5,7
056	734874		OBSOLETE		
057	---	--	World Trade Only	-----	---

3420/3803 REFERENCE GUIDE

ECA	EC	E/A	Description	Checkpoint	Machines Affected
058	734949	A	Improve read reliability on tapes written on some OEM equipment. Modified 7-track read card.	Check for EC 734949 stamped on 7-track read card.	Mods 3, 5,7 with 7-track
059	734954		OBSOLETE-COMPOSITE Decrease the exposure to last records when tape voids are sensed in a backwards operation.	WITH ECA 121	
060	736028		OBSOLETE-REPLACED BY	ECA 117	
061	735811	E	System update for factory only on "C" exit. Mandatory factory only.	None	Mods 4, 6,8
062	736036		OBSOLETE		
063	736803	E	Eliminate possible tape path interference by installing modified filler block.	Check for an "X" molded into the filler block just to the left of the R/W head.	All 4,6,8
064	736932		OBSOLETE-REPLACED	BY ECA 112	
065	735813	A	Corrects a possible interchange problem when reading 1600 bpi records on a 3803-2.	Check 01A-A1K2 for P/N 8237090 or higher.	Mods 4,6,8
066	---	-	World Trade Only	-----	---

3420/3803 REFERENCE GUIDE

ECA	EC	E/A	Description	Checkpoint	Machines Affected
067	736819	A	Reduce reference plate wear by installing improved reel tachs.	3420 all - remove left or right reel tach and look for white dot on the bottom of the housing.	All
068	735815		OBSOLETE-REPLACED BY Correct 237 abends where temp read errors are equal to the record count discrepancy.	ECA 075	
069	736031		OBSOLETE		
070	736828	A	Prevent unload failure due to false not tape present indications.	3420 all - check for a capacitor from 01A-AID2B09 (+).	All
071	736992	A	Prevent transistor on write card from shorting on cartridge motor casting.	Remove front head card cover and check for foam strips inside of the cover.	Mods 3, 5,7, B03, B05, B07
072	735635A	E	Install I/O connectors (ESD problem)	Check for plated I/O shoes on drive.	Mods 4,6,8
073	735817		OBSOLETE-COMPOSITED Allow autocleaner to retract before tape operation to prevent "not capable" unit check on first command after load operation.	WITH ECA 116	
074	736683A		OBSOLETE-REPLACED BY	ECA 112	

3420/3803 REFERENCE GUIDE

ECA	EC	E/A	Description	Checkpoint	Machines Affected
075	735818C	E	Prevent loss of capstan control and adds Cmd tag reset to "crease- check" latch.	Check for card P/N 8237044 or higher in location A1H2	Mods 4, 6,8
076	735166	E	Correct -4V regulator wire on power supplies.	3420-4, 6, and 8 with piggy-back power supply, check for wire No. 1 of cable P/N 1767877 on TB-3-5 on front of the power supply.	Mods 4,6,8
077	737013		OBSOLETE-REPLACED BY Prevent snapping of tape during unload causing tape damage.	ECA 108	
078	733222	E	Eliminate mis-plugging of the read cables on the read card.	Check for label on read cable saying "Rd Card Rear".	Mods 4, 6,8
079	906326	-	World Trade Only	-----	---
080	443868		OBSOLETE		
081	443862	E	Prevent piggy-back power supply regulator diode failure in Model 4,6,8.	Check pre-regulator assembly for P/N 1767871 at E/C 443862	Mods 4, 6,8
082	443870		OBSOLETE-REPLACED BY	ECA 095	
083	443864		OBSOLETE-REPLACED BY	ECA 117 and ECA 118	

3420/3803 REFERENCE GUIDE

ECA	EC	E/A	Description	Checkpoint	Machines Affected
084	443894		OBSOLETE		
085	443893		OBSOLETE		
086	443890	E	Improve the reliability of the auto cleaner.	Check to see that the rewind solenoid valve is a single 3-way valve P/N 4169425.	Mods 4, 6,8
087	443911		OBSOLETE		
088	---	-	World Trade Only	-----	---
089	---	-	World Trade Only	-----	---
090	---	-	World Trade Only.	-----	---
091	---	-	World Trade Only	-----	---
092	---	-	World Trade Only	-----	---
093	---	-	World Trade Only	-----	---

3420/3803 REFERENCE GUIDE

ECA	EC	E/A	Description	Checkpoint	Machines Affected
094	443899	A	Provides plated I/O cable connectors to minimize ESD problems. 3803-1 E/C 443901 is a companion change.	Check for anodized I/O connectors. (silver in color)	Mods 3, 5,7
095	449022	E	Replaced RC network associated with transfer valve and adds a new RC network in the same circuit.	Check for RC network (P/N4169599) on the solenoid contact relay assembly (SCRA) card in the A-C box.	All
096	449014		OBSOLETE-REPLACED BY	VACUUM SWITCH PM KITS	Mods 4, 6,8
097	443935	A	Eliminates 237 abends caused by missing records on tape. Also minimized temporary read errors caused by short gaps or capstan slip.	Check for logic card P/N8250221 at A1 E2 and P/N 8250220 at A1F2.	Mods 4, 6,8
098	---	-	World Trade Only	-----	---
099	443927		CANCELLED-REFER TO Reference plates which are excessively worn by the edges of the tape may cause tape damage and require replacement.	3420 SERVICE AIDS 9 AND 10	
100	---	-	World Trade Only	-----	---

3420/3803 REFERENCE GUIDE

ECA	EC	E/A	Description	Checkpoint	Machines Affected
101	449068	E	Corrects drop ready and other symptoms associated with fluctuation of the 4 and 6 volt supplies.	Check for jumpers from power Intf board terminal E12 to clip on the lower heat sink and terminal E9 to upper heat sink.	B03, B04, B05, B06, B07, B08
102	449087	E	Prevent tape dump and drop ready caused by incorrectly installed mod wires on the tape drive logic boards. Also corrects failures on conversion to Mod 4 or 6 from Mod 7 or 8.	If reel motor boards are other than P/N 373561, P/N 2524137, or P/N 4450016 there should be a wire from 01A-B2B12 to 01A-B2P10.	Mods 4,6
103	---	-	World Trade Only	-----	---
104	449092	A	Help prevent reel motor board failures by decreasing a voltage spike that burns out transistor Q8.	Installs a diode across the HS rewind solenoid.	Mods 3,5
105	846015	E	ECA reserved for the replacement of the cartridge retaining button. Released for recording of time and parts. Cannot be ordered as EC.	Cartridge retaining button should be black or gray in color. If not, order P/N4169428.	All
106	449093	E	Decrease reel motor circuit board failure. Installs 1.3 ohm reel motor current limiting resistors.	1.3 ohm resistors in the reel motor and capstan motor resistor assembly.	Mods 7,8

3420/3803 REFERENCE GUIDE

ECA	EC	E/A	Description	Checkpoint	Machines Affected
107	---	-	World Trade Only	-----	---
108	449080	E	Prevent long backward stop distance.	Check for logic card P/N8251495 or higher at A1G2.	Mods 3,5,7
109	845982	E	Corrects REA that causes velocity errors or T3420T failures.	Check for a wire from A1G3D10 to A1G4B04.	Mod 3
110	846163	E	Prevent system hangs due to multiple busy status.	Check for logic card P/N8565057 at A1H2 (Mod 3,5,7) or A1M2 (Mod 4,6,8).	All
111	846684	E	Warning label for power supply.	Check for label on power supply near AC circuit breaker. Label should have P/N 4452003.	All
112	846320	E	Provide updated logics.	If tab divider page YA001 is present, EC is installed.	All
113	846437		OBSOLETE COMPOSITED	WITH ECA 116 FOR MOD 4,6,8 AND ECA 121 FOR MOD 3,5,7	
114	846916		World Trade Only		

3420/3803 REFERENCE GUIDE

ECA	EC	E/A	Description	Checkpoint	Machines Affected
115	847217	A	Improve loading by replacing R/H threading channel. Provide better sealing the upper restraint, lower stubby bar and the right hand float plate.	<ol style="list-style-type: none"> 1. Thread channel is 4.45inches long 2. Foam gasket at the top of right door float plate 3. Lower stubby bar screws have tubing attached to the threads. 4. Air seal plate on the upper restraint will have mounting screws protruding from the plate. All checkpoints must be on tape unit for EC to be installed.	All
116	847216	A	False write current failure. Also composites ECA 113 and ECA 073. This EC is required on Mod 8's installed on 3081 systems.	Check for logic card P/N8565071 at A1G2.	Mods 4,6,8'
117	847202	E	Install flat belt pneumatic supply.	Check P/N on the face of pneumatic motor pulley ALTITUDE LOW HIGH 60H 8492810 8492814 50H 4450030 4450026	All
118	847262	E	Install air deflector to prevent damage to output pressure filter.	Check for deflector P/N 4169410 inserted in tubing at input to pressure filter.	All
119	847839		World Trade Only		

3420/3803 REFERENCE GUIDE

ECA	EC	E/A	Description	Checkpoint	Machines Affected
120	847861	E	Provide updated logics	Check logic page A1011 (Mod 3,5,7) for E/C level 847861 or later check logic page AA001 (Mod 4,6,8) for EC level 847861 or later.	All
121	847234 B	A/E	<p>(Mod 3,5,7)</p> <ol style="list-style-type: none"> 1. Prevent drop ready due to noise 2. Ease manual rewind of tape 3. Composite ECA 026 4. Composite ECA 053 5. Composite ECA 059 6. Composite ECA 113 7. Composite EC 736816 8. Composite EC 845982 9. Remove stop wires to prevent reel board failures during H.S. rewind <p>(Mod 4,6,8)</p> <ol style="list-style-type: none"> 1. Prevent drop ready due to noise 2. Ease manual rewind of tape 3. Prevent reel board failures during H.S. rewind 4. Improve tape load 	<p>(Mod 3,5,7) Check for card P/N 8565083 in location A1C2.</p> <p>(Mod 4,6,8 only) Check for card P/N 8565083 in location A1C2 and Check for a wire from A1G4B09 to A1C3B04.</p>	All (Mandatory Mod 8)
122	847863	A	Prevent tape bottom on move forward commands.	Check for logic card P/N8565079 at A1B2.	Mods 3,4,5,6

3420/3803 REFERENCE GUIDE

ECA	EC	E/A	Description	Checkpoint	Machines Affected
123	847285	A	Increase anti-bobble current to stop reel motor bobble.	Check for 50 ohm resistor wired in parallel with R1, (10 ohm) resistor at the extreme upper left corner of reel boards P/N2524137.	All with reel motor boards P/N2524137
124	847857	A	Provide adjustable vents on the vacuum columns to allow column balancing for load problems.	Check for 1/4" gap and adjustable plastic vent between column bars and vacuum column.	All
126	---	-	World Trade Only	-----	---
127	847849	E	PM Label	PM Label installed	All
128	---	-	World Trade Only	-----	---



3803 ECA LISTING

THIS IS A LISTING OF NEW EC'S AND EC'S THAT ARE PRE-REQUISITES FOR MES INSTALLATIONS. ALL ECA NUMBERS NOT LISTED ARE OBSOLETE.

E/A

E = Essential

A = Required Change

ECA	EC	E/A	Description	Checkpoint
002	733801	E	Basic sys paper cleanup and 24 wire panel rework C-test exit	Check for wire or land from 01A-A2C5D12 to 01A-A2C5D10.
004	733821	A	Mechanical (cable retention) provide a more positive clamping system for retention of coaxial I/O cables with EC 733763 (ECA 008).	Check for four U-clamps holding coaxial interface cables plugged into 01A-B2 board.
006	733700	E	Power on/off sequence decal	Check for power on/off decal on A.C. supply.
008	733763C	A	Mechanical brackets (Mach. prior to 11000)	Check for U-shape bracket cover, above and below B2 board where the interface cables are plugged.
009	733806C	E	Supply one page of micro programming	Check existence of microcode page 60A of P/N 2521022.

3420/3803 REFERENCE GUIDE

ECA	EC	E/A	Description	Checkpoint
010	733819	A	Provides parts to change rear machine cover roller from brass to rubber and includes slider springs to prevent ESD interference.	Check for brass slider springs on rear machine cover.
011	733826	A	MST-A Alt path switching hangup	Check 01A-B2H2 at EC 733816. Refer to card location list for card EC level.
012	733827	A	Correct check character spacing on NRZI write tape mark. (Both 7 and 9-track NRZI).	Check 01A-A2H2 for P/N8218338 or higher. (NRZI only)
013	733823	A	Mechanical and ESD	Check for ground wire on left side cover (facing wiring side of machine) closest to interface cables from hinge bracket to cover.
015	733816A	E	Board wiring (REAs 24-22946, 22937, 22984). Prior to SN 11000	Check for wire on 01A2 board from H5D11 to H3D05.
016	733815	E	7-track C-test exit. Logic only.	Check EC level of logic page RD171. P/N2517004 at EC733815 (or higher).
018	733816	E	REAs for Emulator problems, guarantee general reset on 145 system, and set stop write NRZI in an overrun condition.	Check for wire on 01A1 board from H3B10 to L2B05.

3420/3803 REFERENCE GUIDE

ECA	EC	E/A	Description	Checkpoint
022	733824	E	7-track C-test exit. Logic only.	Check EC level of logic page RD211. P/N2517008 at EC level 733824 or higher. (7 track only)
024	733814	E/A	New B2 board to meet 370 requirements. Required for 3803 model conversion.	Check B2 board for P/N2521384, P/N1384001, or P/N1384002.
030	733831	A	Basic system - 7 and 9 - track NRZI read (REA 24-24012). Correct noise detection on tracks 3, 4 and 6 for NRZI read W/EC 733816.	Check 01A-A1L2. Refer to card location list for card EC level.
034	733817	E	-Paper only - Supply logic to allow plugging or equivalent imbedded cards.	Check EC level of logic page AA411. P/N2727542 at EC level 733817 (or higher).
036	733841	E	Tie down unused net to prevent noise for causing ROS errors. (REA 24-24058).	Check for tiedown resistor P/N 2520942 (yellow) from A2H2S10 to A2H2S06.
039	733838	A	Allow plugging of cost reduced ALU cards. (REAs 24-24051 and 24- 24054).	Check for card P/N 8218334 in location 01A-A2N2 and 01A-B2C2. Also card P/N 8218332 in 01A-A2M2 and 01A-B2D2.
040	733839	E	Decrease excessive write errors caused by temperature sensitive cards. Obsolete P/N 8218373 and 8218374. (REAs 24-24081 and 24082) (composites ECA 028 and 031).	Check 01A-A1C2 for P/N8230738 or P/N8230739 or higher.

3420/3803 REFERENCE GUIDE

ECA	EC	E/A	Description	Checkpoint
042	734281	E	Correct random power-on resets. Reduce ESD exposure by a capacitor change +6Volt regulator SMS card.	Check for EC 734281 label on top of DC box or check power-on reset card P/N 375382 for EC 136587 or REA 24-24075.
044	733842	E	Reset RDD by -2 time so as not to set lost byte latch with 7-track W/EC 733824. Also corrects several other problems. (See EC listing).	Check for yellow wire from: 01A-A1Q2B11 to 01A-A1Q2D07. (7-track only).
046	733843	E	Lost record due to creased tape. (ECAs 026, 027, and 032 are prerequisites).	Check 01A-A2Q2 for P/N8230746.
047	733844	E	Improve interface ground integrity. (ESD) REAs 24-24070 (electrical), REA 24-24077 (mechanical). Add foam in cable raceways.	Check for wire from 01A-B2U5B07 to 01A-B2V5B07. Raw board EC levels of 732387 and 732391 do not have wire. All machines should have foam in raceway.
050	733848	E	Allow enabling of PE ID burst checking. Provide availability to check PE ID burst at the CE's option.	Check for yellow wire from 01A-A1L5D11 to 01A-A1G3B07.
055	734501	E	Installs a plastic insulator on top of the fan guards in the power supply.	Check for this insulator in the DC power supply.
058	733854	E	Update to switch chart and reference pages.	Check EC level of logic page XC701. EC733854 (or higher).

3420/3803 REFERENCE GUIDE

ECA	EC	E/A	Description	Checkpoint
060	734503	A	Circuit protector change from 10A to 15A for CP17.	Check CP17 for 15 amp breaker in top of ac box.
062	733856	A	Excessive read VRC errors (NRZI Op) REAs 24-24092 (0 TK) 24-24093 (imbedded card), 24-24094 (7-track), 24-24095 (RPQ card).	Check 01A-A1Q2. Refer to card location list for card EC level.
063	734867	A	LWR-NRZI diagnostic "K" fails with read VRC errors (correct 733853) REAs 24-24100 and 24-24101. Mandatory with ECA 057.(Composites ECA 057 and ECA 059).	Check 01A-A1P2. Refer to card location list for card EC level.
064	734289B	E	Improve the electrical and mechanical connection of the filter capacitors of the -4V reg board. Mandatory on machines W/O EC 734512.	Check for a zinc coated copper clip in the slotted holes for the mounting of capacitors in the -4V power supply. Round mounting holes do not need EC.
066	734866	A	Correct improper handling of creases (or contamination which appears as a crease) during some tape operations. Corrects EC 733843.	Check 01A-A1H2. Refer to card location list for card EC level.
068	734872	A	Rewire 01A-B2 board to meet interface specs on machines with EC 733814.	Check for yellow wire from 01A-B2V2D09 to 01A-B2U2D09.

3420/3803 REFERENCE GUIDE

ECA	EC	E/A	Description	Checkpoint
069	734873	A	Extend sample of incremented IC address during long ALU cycles to eliminate wrong branches. (Composites ECA 043, ECA 052, and ECA 065).	Check card locations 01A-A2K2 and 01A-B2F2 for P/N 8236449.
071	735961A	E	Update logics to include replaceable parts in order that power supply asms can be removed from the parts catalog.	Check for EC 735961 or higher on logic page YF036.
076	734111	E	Reduce ESD, I/O channel connector block.	Look for plated connectors on channel interface shoes.
077	734120	E	Keep I/O connectors from coming apart from plated adapter blocks.	Check for screws in the back of the channel I/O shoes to hold the adaptors in place.
078	734099A	E	World Trade Only	-----
079	3803-2, 734879 3803-1, 734878	E A	Correct 237 abends due to unexpected interrupt with zero status and other conditions.	Check for P/N8232753 in 01A-A2T2.
081	736697	E	Eliminate false errors when a write tape mark command is issued.	3803-2 check for card P/N 8237119 in 01A-A2H2.

3420/3803 REFERENCE GUIDE

ECA	EC	E/A	Description	Checkpoint
082	736699	E	Correct tape runaway condition.	3803-2 -Check for continuity between X-Y1T2B07, X-Y1T3D11 and X-Y1T5B02.
083	734877A 734877B	E	Logic update not picked up on parent E/C 734877.	3803-2 -Check logic page FC261 for EC 734877A or higher level. (It should be a white page).
085	736693	E	Improve -4V regulation on the power supply.	On 3803-2 (1X8), check for .16 Ohm resistor (R8), P/N 2521454 on regulator board A2.
087	736934	E	Improve -4V regulation.	3803-1 Jumpers added from heatsink to -4V caps (-)side to C1, C2.
088	736678C	A	Improve electrical connection from the secondary of the ferro transformer to the -4V regulator board assemblies.	3803-1 - Check for round cables from A1 and A2 -4V regulator boards to the ferro transformer.
094	736939	E/A	Change value of frequencycompensating capacitor on +6V and -4V SMS regulator cards. Eliminate 1khz/120mv of ripple at onset of high temperature. 3803-1 (as required), 3803-2 (essential)	(3803-1 and 2) -Check the -4 and +6V regulator cards for EC 736939 or higher.

3420/3803 REFERENCE GUIDE

ECA	EC	E/A	Description	Checkpoint
095	736940	E	Provide an improved bracket for the mounting of 20A circuit breaker.	Remove cover to access rear of 20 amp CB located below the power sequence switches. Check for a one piece bracket that encompasses the 20 amp CB.
099	443885	A	Prevent possible errors caused by phase window being wrong. ECA 121 is concurrent.	Check for P/N8250997 at location 01A-A1C2, A1E2 and A1F2.
100	443901	A	Provides plated connectors in 01T gate for drive cable attachment to minimize ESD problems.	Check for plated connectors in 01T gate (drive connectors).
101	443902	A	Adds plated I/O channel connector block between the internal coax connector and the external channel cable.	Check for plated connector (open 3803 side cover to check).
102	733226	E	Prevents erroneous correction of track 0 when a tie byte of 03 is indicated.	Check for card P/N 8237131 at location 01X-Y1D2.
105	449058	E	Safety change provides visual verification of the installation of four jumpers provided by ECA 087.	None
106	449048	E	Eliminates "B" bus parity errors, IFCCs, ALU1 and ALU2 hangs, and clock card failure indications.	Check for resistors (P/N 2520936) (blue) at 01A-A2M2D13 to 01A-A2M2D08 and 01A-B2E2M11 to 01A-B2E2P08

3420/3803 REFERENCE GUIDE

ECA	EC	E/A	Description	Checkpoint
115	846276	E	Read and write circuitry improvements.	Check card locations 01X - Y1J2 for P/N8565059 and Y1N2 for P/N8565064.
117	846487	E	Update 3803-1/3420MLM/Pathfinder	Check MLM/PF start 1 page for E/C846487.
118	846627	E	Replaced by ECA 123.	-----
119	846927	E	Update 3803 MLMs	Check MLM/PF start 1 page for P/N8492290 at EC846487.
120	847247	E	Update 3803 MLMs	Check MLM page 08-000 for P/N2735812 at EC level 847202.
121	449055	A	Decrease possibility of data substitution without any errors (3803-1).	Check 01A-A1 board part number 9-track - P/N4452272 7-track - P/N4452270 RPQ 870046 - P/N 4452268
122	847282	A	Allows installation of EC733814 on machines with tailgate located at top of unit near B2 board.	I/O gate 01S located at the bottom of the frame (instead of near the 01A-B2 board).
123	847836	E	Enable MIS ping-pause latch to function with MIS feature and pick-up microcode patches 3803-1 and 3803-2.	Check card location 01A-A2G2 for P/N8565073 or 8565076.

3420/3803 REFERENCE GUIDE

ECA	EC	E/A	Description	Checkpoint
124	847221	A	Reduce velocity change errors.	Check card location 01A-A2D2 for P/N8565065 or 8565077.
125	846498	A	Corrects ALU 1 hangs on 3803's with two channel feature.	Check card locations 01A-B2P2 and B2Q2 for card P/N8565082
126	847125	A	Prevent extra "in-tag" from being generated when an overrun condition exists. Also set "P-compare" error if generated "P" does not compare with channel buffer "P" bit.	Check card location 01A-A1C2 for P/N8565080.

3420/3803 REFERENCE GUIDE INDEX

Abends.....	13.0
Abend Codes.....	13.1
ALU Patches.....	17.5
ALU Address Stops.....	17.2
AMP Sensor Adjustment.....	7.7
Belt Part Numbers.....	14.3
Bits in Interblock Gap.....	5.7
Bit Positioning.....	5.4
Bit Packing.....	6.6
Board Ordering - 3803.....	2.1
Board Ordering - 3420.....	2.3
Cable Replacement - 3420.....	2.3
Cable Replacement - 3803.....	2.2
Cabling Requirements - 3803/3420.....	2.4
Capstan Cleaning (Glazed).....	6.2
Capstan Motor Part Number.....	14.7
Capstan Open Segment.....	6.2
Capstan Test.....	6.3
Card Locations, 3803 001 Microprocessor.....	16.1
Card Locations, 3803 002 Microprocessor.....	16.1
Capstan - Performance Enhancement.....	7.5
Capstan, Glazed.....	6.2
Capstan Motor Test.....	6.3
Capstan Motor Part Numbers.....	14.7
Channel Interface.....	18.0
Channel Errors Caused by Disconnect In From 3803.....	18.1
Column Vacuum Leakage Test.....	6.4
Conversion Tips (3803).....	See Retain Tips
Common Media Related Problems.....	10.2
Common Abends.....	13.1
Column Vacuum Leakage Test.....	6.4
Cracked Pressure Hose.....	6.4
Crease Tape Error, False (OLT).....	11.12
Damage, Tape.....	10.2
Data Flow 3420 Read/Write.....	5.13, 5.14
Data Flow 3803 001 Read/Write.....	16.1
Data Flow 3803 002 Read/Write.....	16.1
Damaged Tape.....	10.3
Developing Tape Procedure.....	5.10
Developed Tape Examples.....	5.10
Diagnostics.....	11.0
Disconnect In.....	18.1
Dropping Ready.....	6.2, 6.8
Dumping Tape.....	6.2
DC Voltages.....	MLM 08-570
DC Power.....	12.1
Edge Damage, Tape.....	10.3
Edge Damage.....	10.3
Erase Gap (ERG), Distance.....	5.10
Erase Head, Distance Relationships.....	5.10
Error Criteria.....	4.0

3420/3803 REFERENCE GUIDE

Error, Permanent Read.....	4.0,6.2
Error, Permanent Write.....	4.0,6.2
Error, Temporary Read/Write.....	4.0,6.2
Error Analysis OLT.....	11.12
Error Stops, ALU.....	17.2
ECA Checklist - 3420.....	19.0
ECA Checklist - 3803.....	20.0
EREP.....	4.0
ERP (Error Recovery Program).....	5.1
Factors That May Indicate A Failing Head.....	5.8
False Crease Tape Error.....	11.12
Feature Codes - 3420.....	See 3420 Service Aids
Feature Codes - 3803.....	See 3420 Service Aids
Feature Identifier - 3803 Model 1.....	See 3420 Service Aids
Feature Installation Times - 3803.....	See 3420 Service Aids
Forward/Backward Ratio Test (Mod. 3,5,7).....	7.10
Forward/Backward Ratio Test (Mod. 4,6,8).....	7.9
FUR Replacement/Swapping.....	5.4
Glazed Capstan.....	6.2
Glazed Capstan Cleaning.....	6.2
Grommet Part Numbers.....	14.6
Hang, ALU.....	17.2
Head, Distance Relationships.....	5.10
Head Pin Layout (Mod. 3,5,7).....	5.15
Head Pin Layout (Mod. 4,6,8).....	5.14
Head Wear Test (Mod. 3,5,7).....	7.11
Head Wear Test (Mod. 4,6,8).....	7.9
Head Failures.....	5.8
Holley Monitor Trap.....	18.3
How To Make Your Diagnostics More Effective.....	11.6
Interblock Gap, Noise In.....	5.7
Interblock Gap Size.....	5.11
Interface, Channel.....	18.0
Initial Checks - Performance Enhancement.....	7.2
Interchangeable Cards, 3803 Microprocessor.....	17.4
Leaking Transfer Valve Leakage Test.....	6.5
Leaking Vacuum Column Door.....	7.3
Left Vacuum Column Switch Kits.....	14.4
Library Quality.....	10.1
Locations, Microprocessor Cards.....	17.4
Magnetic Tape General Information.....	10.1
Magnetic Tape.....	10.1
Media Related Problems.....	10.1
Media and Related Problems.....	10.0
Media Problems.....	10.2
Microprocessor Card Interchange List - 3803.....	17.4
Microprocessor Card Locations - 3803.....	17.4
Missing Oxide.....	10.3
Microprocessor Card Locations.....	17.4
Microprocessor Card Interchange List.....	17.4
Microprogram EC's.....	17.5
Monitor, Holley.....	18.3
Motion Service Techniques.....	6.0
Motor Part Numbers.....	14.7

3420/3803 REFERENCE GUIDE

MLM, Description and Organization 3803-1.....3.1
 MLM, Description and Organization 3803-2.....3.4
 MST Board Ordering - 3420.....2.3
 MST Board Ordering - 3803.....2.1
 Noise or Bits in the Interblock Gap.....5.7
 NFT, Read/Write.....5.8
 NTF (No Trouble Found) Checklist, Power.....12.1
 NTF, Tape Motion.....6.7
 NTF Read/Write Checklist.....5.8
 Online Tests (OLTs).....11.0
 Oxide Voids.....10.3
 OLTs.....11.0
 OLT General Strategy.....11.6
 OLTs Sense Switch Instructions.....11.7
 OLT EXT = Option Instructions.....11.8
 OLT Error Analysis.....11.12
 OLT Options.....11.8
 Part Numbers, Common.....14.0
 Partially Erased Records.....6.2
 Patch Card 3803-1.....17.5
 Patch Card 3803-2.....17.5
 Part Numbers (3420).....14.0
 Permanent/Temporary Errors.....4.0,6.2
 Phase Errors.....5.3
 Phase Shift.....5.5
 Phase Shift Scoping Procedure.....5.6
 Phase Pointers.....5.6
 Piggy-Back Supply.....14.7
 Pneumatic Belts (Part Numbers).....14.3
 Pneumatic System - Performance Enhancement.....7.2
 Power Check.....12.0
 Power No Trouble Found Check List.....12.0
 Power Service Techniques.....12.0
 Power System, Modified 90XXX.....14.7
 Power Supplies.....12.1
 Power Check.....12.1
 Pressure Hose, Cracked.....6.4
 Pre-Regulator (Power).....14.7
 Pressure Tubing Kit.....14.4
 PM Schedule - 3420.....MLM 85-000
 PM Schedule - 3803.....MLM 85-000
 PM Kits - 3420.....14.4
 Ratio Test, Read Forward/Backward.....7.9,7.11
 Read/Write - Performance Enhancement.....7.6
 Read/Write Service Techniques.....5.0
 Read/Write Failure Analysis.....5.3
 Read/Write Head Failures.....5.8
 Read Only Tape.....11.12
 Read Amplitude Adjustment (Mod 4,6,8).....7.7
 Read Data Flow - 3420.....5.14,5.15
 Read Data Flow - 3803 Model 1.....16.1
 Read Data Flow - 3803 Model 2.....16.1
 Read Error, Permanent.....4.0,6.2
 Read/Write Errors.....4.0,6.2

Read/Write Head (Distance Relationships).....	5.10
Read/Write Head (Pin Layout).....	5.14, 5.15
Read/Write Head (Wear Test).....	7.8, 7.9
Read/Write No Trouble Found Checklist.....	5.8
Read/Write Service Techniques.....	5.0
Read Only Tape.....	11.12
Ready, Dropping.....	6.8
Reel Board and Motor Part Numbers.....	14.1
Resistor, Tie Up/Tie Down.....	2.1
Right Vacuum Column Switch Kits.....	14.4
ROS Patch Card.....	17.5
ROS Patches.....	17.5
Sales Feature Codes - 3420.....	See 3420 Service Aids
Scoping Procedures, Phase Shift.....	5.6
Section Read/Write Error Analysis.....	11.12
Sense Bytes, Tape Motion.....	6.1
Sense Bytes, Read/Write.....	5.2
Sense Analysis.....	9.0
Service Techniques, Power.....	12.0
Service Techniques, Read/Write.....	5.0
Service Techniques, Tape Motion.....	6.0
Signal Stability.....	5.3
Slipping Tape.....	6.2, 6.6
Stress Tape.....	11.13
Staggered Wraps.....	10.2
Stress Tape.....	11.13
Switches, Vacuum Column.....	14.5
Switches, Transport.....	14.6
SAGC.....	7.12
Tape Label Example.....	5.12
Tape Error Examples.....	5.13, 6.6
Tape Damage.....	10.3
Tape Edge Damage.....	10.3
Tape Motion Service Techniques.....	6.1
Tape Motion Symptoms.....	6.2
Tape Damage.....	10.3
Tape Developing Procedure.....	5.10
Tape Mark, Missing.....	13.2
Tape, Master Signal Level.....	MLM 80-000
Tape, Master Skew.....	MLM 80-000
Tape Motion No Trouble Found Checklist.....	6.7
Tape Motion Service Techniques.....	6.0
Tape Slipping.....	6.6
Tape Winds Uneven.....	10.2
Temporary/Permanent Errors.....	4.0, 5.1
Tie Up/Tie Down Resistors.....	2.1
Tools and Test Equipment.....	15.1
Tracking Check.....	5.3
Transfer Valve Leakage Test.....	6.5
Transfer Valve Leaking.....	6.2
Transfer Valve - Part Numbers.....	14.7
Transport Switch Kits.....	14.4
Turn Around Delay.....	17.5
Tubing Kits.....	14.4

3420/3803 REFERENCE GUIDE

Vacuum Column Door Leaking.....7.3
Vacuum Column Switches.....14.5
Vacuum Tubing Kit.....14.4
Velocity Patch.....17.5
Voltages DC.....12.1
Write Data Flow - 3420.....5.14,5.15
Write Data Flow - 3803.....16.1
Write Error.....4.0
Z Folds.....10.3
3420 Performance Enhancement Guide.....7.0
3420 Quick Fix Maps.....8.0
3420 Read/Write Service Techniques.....5.0
3420 Read/Write NTF Checklist.....5.8
3420/3803 Online Tests Description.....11.1
3420 OLT Sense Switches.....11.7
3420 Account Checklist.....7.13
3420 Checklist.....7.15
3420 Power NTF Checklist.....12.1
3420 Power Service Techniques.....12.1
3420 Tape Motion Service Techniques.....6.0
3420 Tape Motion NTF Checklist.....6.7
3420 Parts.....14.0
3420 PM Kits.....14.4
3803 Checklist.....7.14
3803/3420 DC Power Supply Checks and Adjustments.....12.1
3803 Power.....12.1
3803 Data Flow.....16.1
3803 Microprocessor Tips.....17.1
3803 Channel Interface.....18.0

BIBLIOGRAPHY

IBM 3803-1/3420 Magnetic Tape Subsystem; Component Description, Order Number GA32-0020, for functional descriptions of the IBM 3803-1 Control Unit and the IBM 3420 Magnetic Tape Units, Models 3,5 and 7.

IBM 3803-2/3420 Magnetic Tape Subsystems; Subsystem Description, Order Number GA32-0021, for functional descriptions of the IBM 3803-2 Control Unit and the IBM 3420 Magnetic Tape Units, Models 4,6 and 8.

IBM 3803-1/3420 Magnetic Tape Subsystem; Installation Manual, Order Number SY32-5026, for information and checklists for field installation and checkout of the subsystem.

IBM 3420 Operator's Guide Card, Order Number G232-0003, for information about operating the tape units.

IBM System/360/370 Reference Data; 2401-2402,2415,3410-3411, and 3420 Magnetic Tape Units, Order Number GX35-5001, for guidelines for estimating tape processing times and block capacities.

IBM 3803-1/3420 Magnetic Tape Subsystem; Theory-Diagrams Manual, Order Number SY32-5024, for a training guide for the subsystem's principles of operation and for diagrams relating to training and maintenance.

IBM 3803 Tape Control Model 1 to Model 2 and IBM 3420 Magnetic Tape Models 3 Through 8 Customer Conversion Guide, Order Number GA32-0023.

IBM Field Engineering; Theory of Operation; Tape Subsystem Error Recording and Analysis, Order Number SY32-5015, for an understanding of statistical error data recording programs and their messages.

IBM 3803 Magnetic Tape Subsystem, Illustrated Parts Catalog, Order Number S132-0004, for listing and illustrations of all parts and assemblies in the control unit.

IBM 3420 Magnetic Tape Unit, Models 3,5, and 7; Parts Catalog, Order Number S132-0005, for listings and illustrations of all parts and assemblies in Models 3,5, and 7, of the tape unit.

3420/3803 REFERENCE GUIDE

IBM 3420 Magnetic Tape Unit, Models 4,6, and 8; Parts Catalog, Order Number S132-0007, for listings and illustrations of all parts and assemblies in Models 4,6, and 8 of the tape unit.

IBM System/360 and System/370 I/O Interface; Channel to Control Unit; Original Equipment Manufacturers' Information, Order Number GA22-6974, for electrical, mechanical, and cabling information about channel/control unit interfaces.

Tape Specifications for IBM One-Half Inch Tape Drives: At 556 and 800 bpi and 3200 fci, Order Number GA32-0006, for specifications and requirements for magnetic tape to be used with IBM magnetic tape units.

IBM System/370 Reference Data, Order Number GX20-1850, for the summary of System/370 operation codes, condition codes, etc.

Environmental Editing and Printing (EREP) Program, Order Number GC28-0772. This publication describes how EREP can be used to generate reports containing different errors and system conditions recorded on error recording data sets. (ERDS)

These publications are available from the IBM Distribution Center.

Note: Listings of the online-test programs are available (on microfiche) from the IBM Program Information Department (PID). Use IBM Diagnostic Order forms, Order Numbers ZZ25-0506 and ZZ25-0507, to obtain listings, online tests, online test publications, and microfiche. Once an appropriate initial order is placed, listings are automatically updated by distributions from PID.



Your comments and constructive criticism regarding this publication will help us improve it and will be appreciated. Each comment will be reviewed carefully by those responsible for the publication. Thank you for your cooperation.

Is the level of coverage adequate?

Is there other information that should be included?

Other comments:

Reader's Comment Form

Fold and tape

Please Do Not Staple

Fold and tape



**NO POSTAGE
NECESSARY
IF MAILED
IN THE
U.S.A.**

BUSINESS REPLY MAIL
FIRST CLASS PERMIT NO. 40 ARMONK, NY

Postage will be paid by addressee

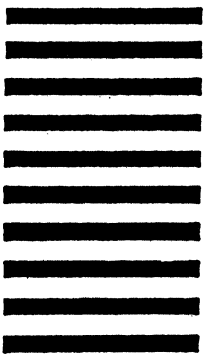

**International Business Machines Corporation
Field Engineering Service Planning
Department 96F, Building 005
Tucson, Arizona 85744**

Fold and tape

Please Do Not Staple

Fold and tape



**International Business Machines Corporation
Field Engineering Division
360 Hamilton Avenue, White Plains, N.Y. 10601**

S229-5910-0

IBM 3420/3803 Magnetic Tape Subsystem Reference Guide Printed in U.S.A. S229-5910-0



International Business Machines Corporation
Field Engineering Division
360 Hamilton Avenue, White Plains, N.Y. 10601