

SPU2 Overview

Copyright © 2002 Sony Computer Entertainment Inc.
All Rights Reserved.
SCE Confidential

© 2002 Sony Computer Entertainment Inc.

Publication date: April 2002

Sony Computer Entertainment Inc.
1-1, Akasaka 7-chome, Minato-ku
Tokyo 107-0052 Japan

Sony Computer Entertainment America
919 East Hillsdale Blvd.
Foster City, CA 94404, U.S.A.

Sony Computer Entertainment Europe
30 Golden Square
London W1F 9LD, U.K.

The *SPU2 Overview* is supplied pursuant to and subject to the terms of the Sony Computer Entertainment PlayStation® license agreements.

The *SPU2 Overview* is intended for distribution to and use by only Sony Computer Entertainment licensed Developers and Publishers in accordance with the PlayStation® license agreements.

Unauthorized reproduction, distribution, lending, rental or disclosure to any third party, in whole or in part, of this book is expressly prohibited by law and by the terms of the Sony Computer Entertainment PlayStation® license agreements.

Ownership of the physical property of the book is retained by and reserved by Sony Computer Entertainment. Alteration to or deletion, in whole or in part, of the book, its presentation, or its contents is prohibited.

The information in the *SPU2 Overview* is subject to change without notice. The content of this book is Confidential Information of Sony Computer Entertainment.

 and PlayStation® are registered trademarks, and GRAPHICS SYNTHESIZER™ and EMOTION ENGINE™ are trademarks of Sony Computer Entertainment Inc. All other trademarks are property of their respective owners and/or their licensors.

About This Manual

The "SPU2 Overview" describes the functions, configuration, and sound generation mechanisms of the SPU2, the sound processor for the PlayStation 2.

- Chapter 1 "Overview of SPU2" describes the configuration and main functions of the SPU2 and the format of waveform data used as a sound source.
- Chapter 2 "Sound Generation" describes voice generation using waveform data as a sound source, sound data stream input/output, mixing, and effects.
- Chapter 3 "Register List" describes the registers that control the SPU2.
- Chapter 4 "Appendix" shows the volume variation rates for values of the envelope rate parameters.

Changes Since Release of 5th Edition

Since release of the 5th Edition of the SPU2 Overview Manual, the following changes have been made. Note that each of these changes is indicated by a revision bar in the margin of the affected page.

Ch. 2: Sound Generation

- Section 2.2.6. Monaural Output, has been added on page 29.
- A correction has been made to the description following Figure 2-12 Sound Data Output on page 31.

Ch. 4: Appendix

- A correction has been made to the "Time" heading in the Exponential Decrement Mode table on page 76.
- A correction has been made to the "0.1110" row in the Linear Decrement Mode table on page 78.

(This page is left blank intentionally)

Glossary

Term	Definition
EE	Emotion Engine. CPU of the PlayStation 2.
EE Core	Generalized computation and control unit of EE. Core of the CPU.
COP0	EE Core system control coprocessor.
COP1	EE Core floating-point operation coprocessor. Also referred to as FPU.
COP2	Vector operation unit coupled as a coprocessor of EE Core. VPU0.
GS	Graphics Synthesizer. Graphics processor connected to EE.
GIF	EE Interface unit to GS.
IOP	Processor connected to EE for controlling input/output devices.
SBUS	Bus connecting EE to IOP.
VPU (VPU0/VPU1)	Vector operation unit. EE contains 2 VPUs: VPU0 and VPU1.
VU (VU0/VU1)	VPU core operation unit.
VIF (VIF0/VIF1)	VPU data decompression unit.
VIFcode	Instruction code for VIF.
SPR	Quick-access data memory built into EE Core (Scratchpad memory).
IPU	EE Image processor unit.
word	Unit of data length: 32 bits
qword	Unit of data length: 128 bits
Slice	Physical unit of DMA transfer: 8 qwords or less
Packet	Data to be handled as a logical unit for transfer processing.
Transfer list	A group of packets transferred in serial DMA transfer processing.
Tag	Additional data indicating data size and other attributes of packets.
DMAtag	Tag positioned first in DMA packet to indicate address/size of data and address of the following packet.
GS primitive	Data to indicate image elements such as point and triangle.
Context	A set of drawing information (e.g. texture, distant fog color, and dither matrix) applied to two or more primitives uniformly. Also referred to as the drawing environment.
GIFtag	Additional data to indicate attributes of GS primitives.
Display list	A group of GS primitives to indicate batches of images.

(This page is left blank intentionally)

Contents

1. Overview of SPU2.....	9
1.1. Features of SPU2	10
1.1.1. Core.....	10
1.1.2. Sound Data Input Function.....	10
1.1.3. Voice Processing Function	10
1.1.4. Sound Data Output Function.....	11
1.1.5. Digital Effect Processing.....	11
1.1.6. Local Memory.....	11
1.1.7. External Output.....	12
1.2. Local Memory	13
1.2.1. Data Allocated in Local Memory	13
1.2.2. Addressing in Local Memory.....	14
1.2.3. Interrupt by Access	14
1.3. Waveform Data Format.....	15
1.3.1. Waveform Data Block	15
1.3.2. Endpoint.....	15
1.3.3. Loop Processing.....	16
1.4. Reset	17
2. Sound Generation	19
2.1. Voice Processing.....	20
2.1.1. Sound Sources.....	20
2.1.2. Pitch Transformation.....	22
2.1.3. Pitch Modulation.....	23
2.1.4. Envelope.....	24
2.1.5. Volume	25
2.1.6. Key-On/Key-Off.....	26
2.1.7. Mixing Switch	27
2.2. Sound Data Input Processing.....	28
2.2.1. Sound Data Input Area	28
2.2.2. Volume Processing.....	28
2.2.3. Mixing with Voice Output	29
2.2.4. Bypass Processing (CORE0)	29
2.2.5. 32-bit Sound Data Input (CORE1)	29
2.2.6. Monaural Output.....	29
2.3. Sound Data Output Processing	30
2.4. Mixing.....	32
2.5. Digital Effect Processing	33
2.5.1. Signal Flow for Digital Effect Processing.....	33
2.5.2. Work Area for Digital Effect Processing.....	33
2.5.3. Effect Volume	34

2.6. Master Volume	35
2.7. Interrupt Processing.....	36
3. Register List	39
3.1. Classification of Registers.....	40
3.2. Registers in Pairs.....	41
VOLL / VOLR : Voice volume.....	42
PITCH : Pitch when sound is generated.....	44
ADSR1 / ADSR2 : Envelope.....	45
ENVX : Current value of envelope	46
VOLXL / VOLXR : Current value of volume	47
PMON0 / PMON1 : Pitch modulation specification.....	48
NON0 / NON1 : Voice allocation to noise generator.....	49
VMIX* : Mixing specification of voice output	50
MMIX : Output specification after voice mixing.....	51
IRQAH / IRQAL : Interrupt address specification.....	52
KON0 / KON1 : Key-on specification.....	53
KOF0 / KOF1 : Key-off specification.....	54
TSAH / TSAL : Transfer start address.....	55
SSAH / SSAL : Starting address of waveform data	56
LSAXH / LSAXL : Address of loop point	57
NAXH / NAXL : Address of waveform data to be read next.....	58
ESAH / ESAL : Starting address in the work area for effect processing	59
EEAH : End address in the work area for effect processing.....	60
ENDX0 / ENDX1 : Endpoint passing flag	61
MVOLL / MVOLR : Master volume	62
EVOLL / EVOLR : Return volume of effect.....	64
AVOLL / AVOLR : Volume for external input	65
BVOLL / BVOLR : Volume for sound data input.....	66
MVOLXL / MVOLXR : Current value of master volume.....	67
4. Appendix	69
4.1. Rate Parameter Table.....	70
4.1.1. +Lin Mode.....	71
4.1.2. -Lin Mode	72
4.1.3. +Exp Mode (Normal phase).....	73
4.1.4. +Exp Mode (Reverse phase).....	74
4.1.5. -Exp Mode	75
4.1.6. Decay Rate (DR)	76
4.1.7. Sustain Level (SL)	77
4.1.8. -Lin Mode for Release Rate (RR).....	78
4.1.9. -Exp Mode for Release Rate (RR)	79

1. Overview of SPU2

This chapter provides an overview of the SPU2.

1.1. Features of SPU2

The SPU2 is a sound synthesis processor, which is composed of two cores. The SPU2 also contains local memory and external I/O.

The two cores have the ability to:

- Reproduce sound data input successively from the host.
- Process voices.
- Output voice-processed sound data to the host successively.
- Perform digital effect processing.

The following sections describe the SPU2 components and core functions.

1.1.1. Core

The cores (CORE0 and CORE1) are the basic components of the SPU2, each having a sound generation function with 24 voices. They operate at a frequency of 36.864 MHz, and have a sound generation resolution of 48 kHz. The unit of processing, 1/48000 second, is represented as 1Ts.

When setting the same register successively (e.g. when varying the pitch of a sound consecutively to realize a portamento), write operations to the register must be at least 1Ts apart. (Write operations to some registers must be at least 2 Ts apart. For details, refer to the Description for each register in "3. Register List".) If the register is written in less than the specified time interval (less than 1 Ts when not specified), the SPU2 operations become indeterminate, and expected results cannot be obtained. This produces serious effects, particularly on registers working as a switch, such as key-on or key-off.

CORE0 and CORE1 are functionally equal and operate independently. They are connected in such a way that the output from CORE0 is input to CORE1 and the final mixed sound is output from CORE1.

1.1.2. Sound Data Input Function

The sound data input function processes 16-bit or 32-bit data strings transferred successively from the host to the SPU2 as sound data, and outputs them by mixing with the voice-processed output. CORE0 and CORE1 each have one stereo input channel.

The input buffer is a reserved area in the local memory. To transfer data smoothly, it uses a double buffer function, which requests a data transfer when half of the area is processed.

For details, refer to "2.2. Sound Data Input Processing".

1.1.3. Voice Processing Function

Sound in the SPU2 is generated in units of voices. Each core has 24 voices, so the whole SPU2 can generate 48 voices.

Each voice has waveform data compressed by ADPCM as a sound source. After pitch transformation, pitch modulation and envelope processing, the outputs of each voice are mixed and become the final sound output.

Sound Source

The sound source is waveform data that has been compressed by ADPCM, and is decoded (decompressed) by hardware at a sampling rate of 48 kHz. The noise generator of each core can be used as a sound source as well.

Pitch Transformation

Sound can be generated by varying the pitch of the sound source within the range of -12 octaves to +2 octaves.

Pitch Modulation

The pitch of the sound source can be modulated by using the crest value of another voice.

Envelope Processing

The envelope, which controls volume variation from key-on to key-off, is specified with five parameters: Attack Rate, Decay Rate, Sustain Rate, Sustain Level and Release Rate. For Attack Rate, Sustain Rate and Release Rate, non-linear variation can be specified.

Voice Volume

Volume can be set for the L channel and R channel of each voice. Constant, linear and exponential variation curves can be selected.

Mixing/Switching

24 voices/stereo output (48 channels in total) are synthesized into 2 stereo units in each core. Each voice can be added to the output or not.

Refer to "2.1. Voice Processing" for details of voice processing.

1.1.4. Sound Data Output Function

Mixed sounds (2 stereo units per core) and a specified two-channel voice can be output to the host successively. This allows the sound data generated by the SPU2 to be processed by the host processor.

An output buffer is reserved in the local memory. In order to transfer data smoothly, it uses a double buffer function, which requests a data transfer when half of the area is processed.

Refer to "2.3. Sound Data Output Processing" for details.

1.1.5. Digital Effect Processing

Digital effects such as reverb, echo and delay can be applied to the mixed sounds.

Although digital effects can be processed independently in each core, the effects in CORE1 can be reapplied to the final output from CORE0.

The work area for digital effect processing is in the local memory.

Refer to "2.5. Digital Effect Processing" for details.

1.1.6. Local Memory

The SPU2 has 2 MBytes (16 Mbits) of local memory for its exclusive use. This memory is used as a buffer for sound data I/O, a waveform data area for voice processing, and a work area for digital effect processing. The remaining memory can be used freely.

It is possible to access the local memory from the host via DMA transfer or single transfer. Sound generation never stops when transferring data, but it might not be correctly executed when overwriting waveform data being used by the SPU2. To avoid this, an interrupt can be generated for the host when each core accesses a specific address in the local memory.

Refer to "1.2. Local Memory" for details.

1.1.7. External Output

The SPU2 adopts the following functions as methods of outputting final sounds.

- Digital output through S/PDIF (Sony/Philips Digital Interface)
- Analog output through D/A converter

1.2. Local Memory

The local memory is memory for the SPU2's exclusive use; it is used as a data I/O buffer with the host and as a work area of the SPU2.

1.2.1. Data Allocated in Local Memory

The local memory is divided into the following four areas.

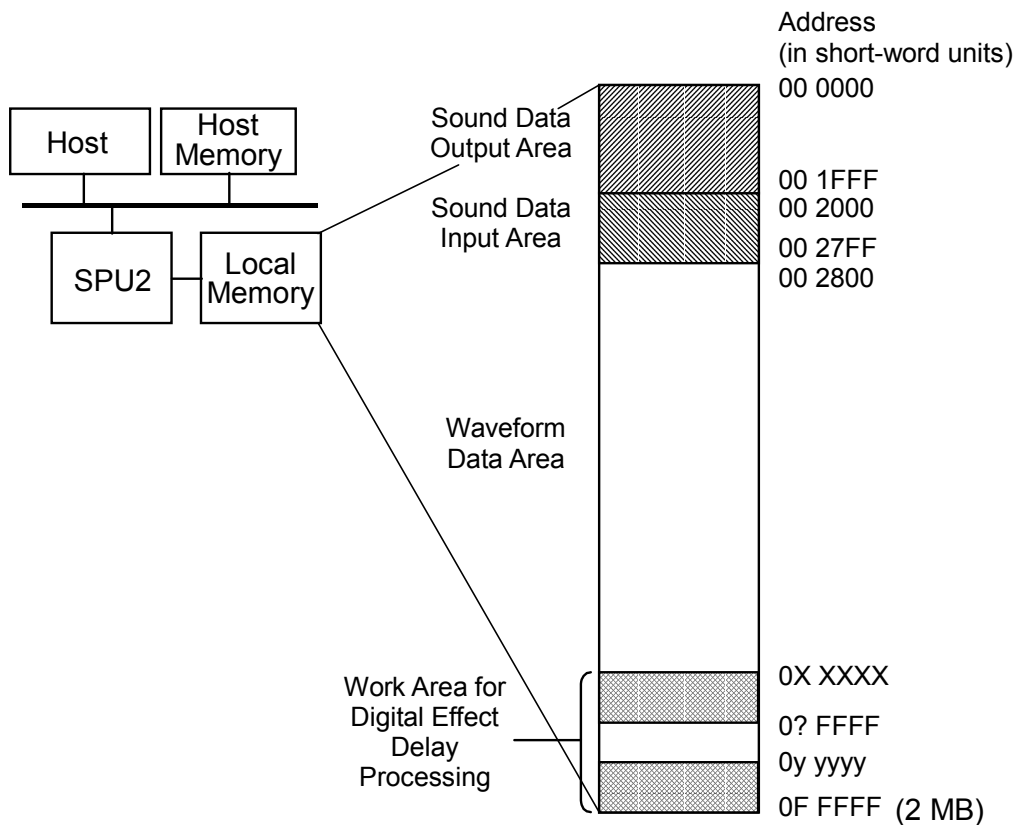

Figure 1-1 Memory Allocation and Addressing in Local Memory

Sound Data Input Area

This is the sound data input buffer from the host; its address is fixed.

Sound data is successively written from the host, and the written data is sequentially read via hardware and processed as sound data by the SPU2.

Sound Data Output Area

This is the sound data output buffer from the SPU2 to the host; its address is fixed.

Sound data generated in the SPU2 is written successively, and is readable from the host sequentially.

Digital Effect Work Areas

The work areas used by the cores for digital effect delay processing are in 2 locations. The start address of each location can be set freely, but the end address has restrictions on alignment.

1.2.2. Addressing in Local Memory

The local memory is configured in 16-bit units; addresses are allocated every 16 bits (short word). Each address is specified with a 32-bit value, of which 22 bits are enabled. The lower 20 bits of the 22 bits show a range of 2 Mbytes, and the upper 2 bits are set to 00.

Since the SPU2 registers are configured in 16-bit units, each register which performs addressing is a pair of high and low registers.

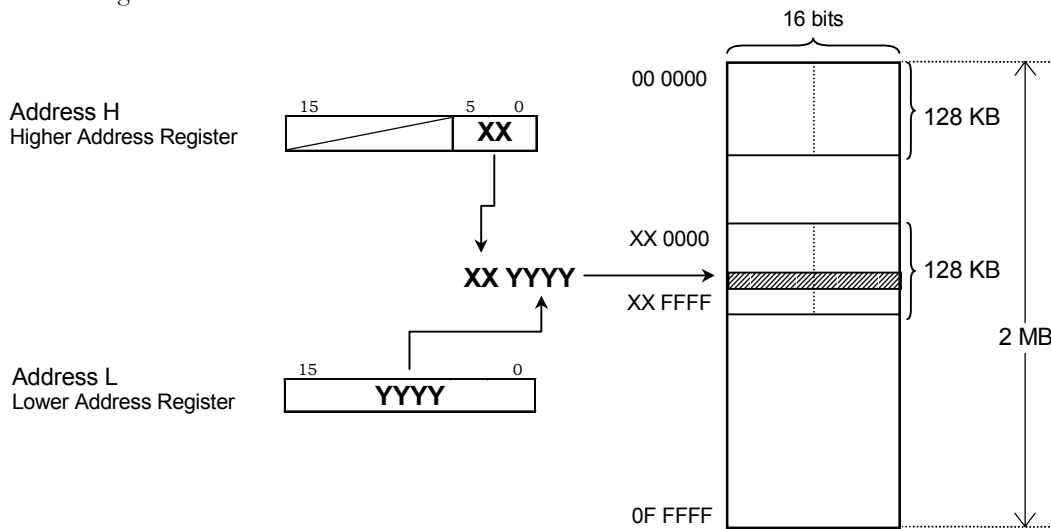

Figure 1-2 Addressing

1.2.3. Interrupt by Access

When one of the cores accesses a specific address in the local memory, an interrupt can be generated for the host. The address for generating an interrupt can be set, one per core, with the IRQAH and IRQAL registers. Interrupts generated by both cores are detected at the same time on the host. A function provided by the sound library represents which core has generated the interrupt.

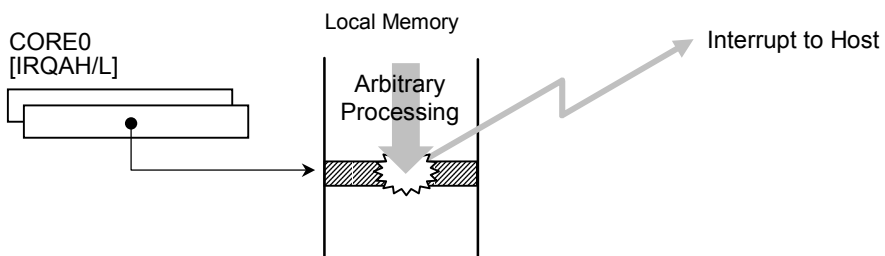

Figure 1-3 Interrupt by Process Access

(Example: Specification in CORE0)

For details, refer to "2.7. Interrupt Processing".

1.3. Waveform Data Format

The waveform data that becomes the sound source of each voice is in a format unique to the SPU2, by adopting ADPCM as a compression method.

1.3.1. Waveform Data Block

Waveform data is configured in units of 16-byte blocks, each of which includes a 16-bit header and 28 4-bit samples. The following attributes are included in the header.

Field	Bit Position	Contents
LOOP/START	10	Loop point information
LOOP	9	Loop existence/non-existence
LOOP/END	8	Endpoint information
DECODE	7:0	Parameter for decoding

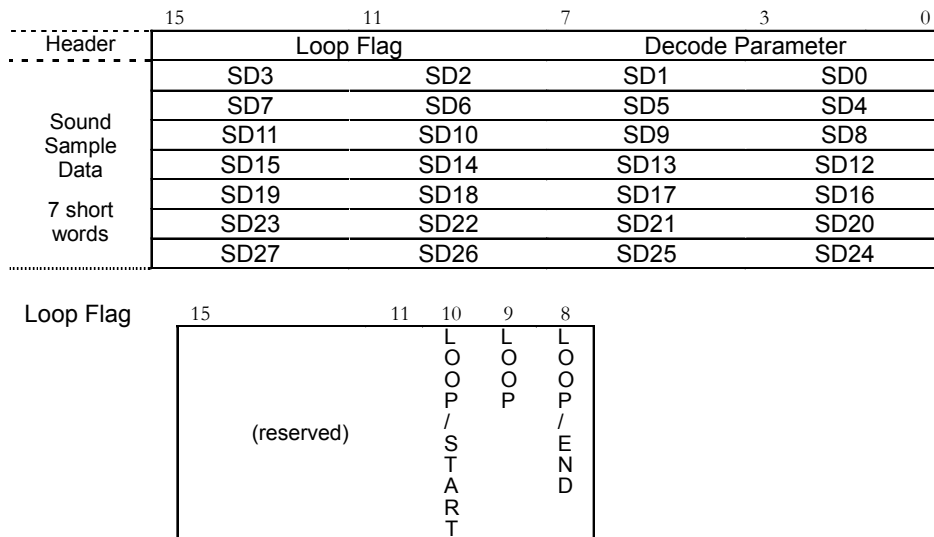

Figure 1-4 1 Block of Waveform Data

1.3.2. Endpoint

The number of blocks of waveform data is arbitrary. By setting the LOOP/END bit of the header to 1, the endpoint is specified, showing the position where the waveform data ends.

When sound generation reaches the block specified as the endpoint, the last sample data of the block is processed, and then sound generation moves to the block which has the loop point specification immediately before (i.e. the block shown by the LSAXH/L register). When no loop is specified, the last sample data of the block is processed, and then muting is applied to the voice in process by hardware. As a result, sound generation of the voice stops.

1.3.3. Loop Processing

By setting the LOOP/START bit of the header to 1, the loop point is specified. The header address is maintained in the LSAXH/L register when sound generation moves to this block, and sound generation moves to the first sample data of this block after processing the endpoint block.

Only 1 loop point specification can be in effect in a set of waveform data. If there are two or more loop point blocks, the block closest to the endpoint becomes the loop point when sound is actually generated.

If an address is set in the LSAXH/L register after sound generation has started, the loop point specification in the waveform data is disregarded until the next time the voice is keyed on, and the set address becomes the loop point.

For waveform data with a loop point set, the LOOP bit of the header must be set to 1 in all blocks.

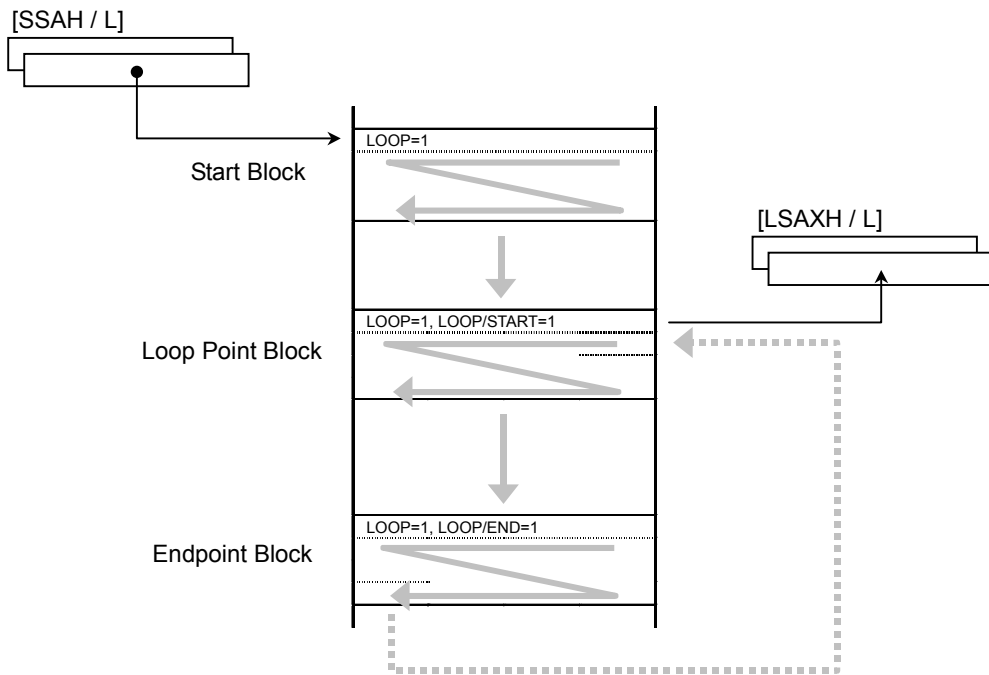

Figure 1-5 Loop Processing

1.4. Reset

The sound library provides a resetting feature. In resetting, neither register values nor data in the local memory is guaranteed.

(This page is left blank intentionally)

2. Sound Generation

This chapter describes sound generation in each core.

2.1. Voice Processing

Voice processing generates sound primarily by decoding waveform data and varying the decoded sound data by time.

The generated sound is transferable to the host as data, and can also be processed on the host.

The entire flow of voice processing is shown as follows:

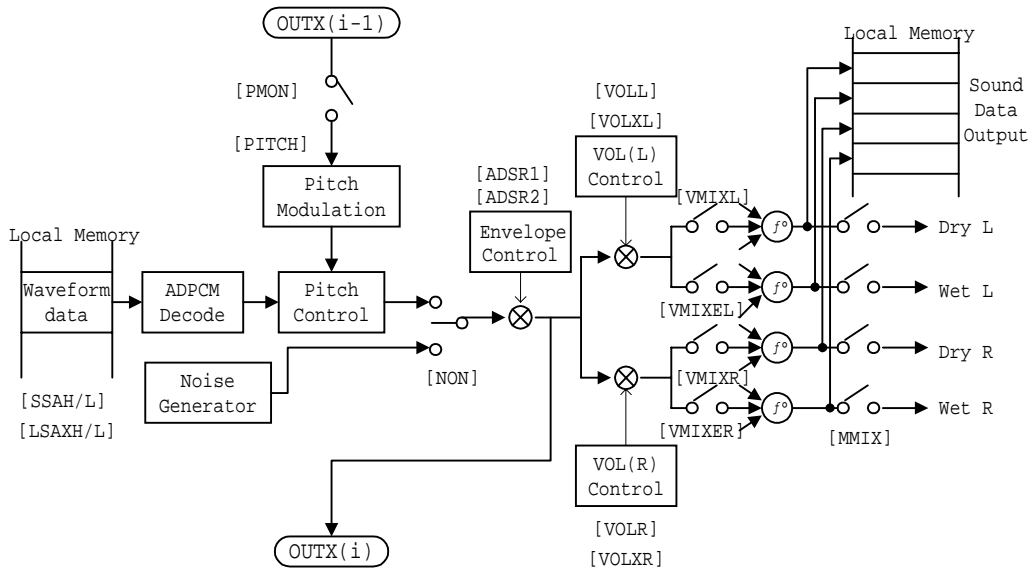

Figure 2-1 Voice Processing

2.1.1. Sound Sources

Waveform data stored in the local memory or the noise generator (each core has 1 unit) can be used as a sound source for each voice. This selection is specified by the NON0/1 register.

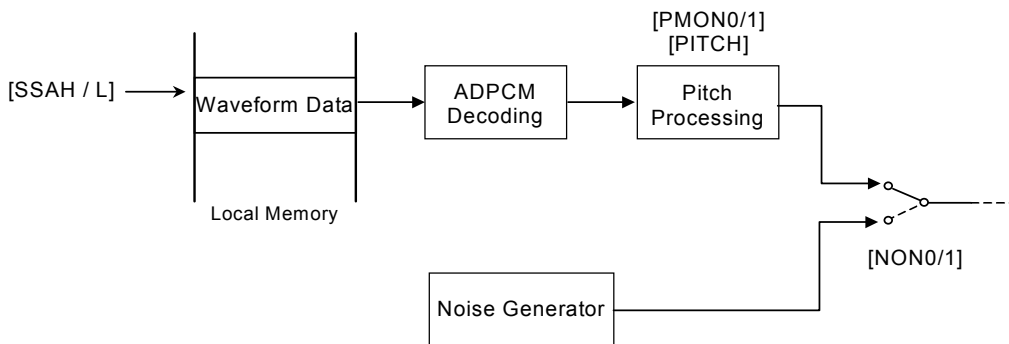

Figure 2-2 Switching between Waveform Data and Noise Generator

When waveform data is the sound source, the address in the local memory where the waveform data is located is specified by the SSAH/L register of the voice attribute. Specify the location of the header in the waveform data block to the SSAH/L register.

Since each voice generates a single tone, it is necessary to vary the pitch of the same sound in two or more voices to generate a chord. In this case, however, the same waveform data address is specified to the SSAH/L register in each voice.

The waveform data is decoded by hardware. The user can know the decoding progress from each of the following registers:

- Address of the waveform data to be read next (NAXH/L register)
- Header address in the loop point block (LSAXH/L register: after passing the loop point)
- Endpoint block passing flag (ENDX0/1 register)

The NAXH/L register is incremented as decoding advances and shows up to which sample data the sound generation has been completed. That is, sound processing has been completed up to the address immediately preceding the one indicated by the NAXH/L register.

Since the waveform data includes the header, however, the above does not mean all the addresses before the one indicated by the NAXH/L register have been processed. When replacing the sound-generated waveform data, replacements can be made in block units up to the block immediately before the one having the address specified by the NAXH/L register. (However, if a replacement is made at a place between the loop point and endpoint in waveform data including loop processing, decoding becomes discontinuous and might cause a noise.)

When decoding advances to the loop point block, the header address in the block is written to the LSAXH/L register. The loop point can be changed by rewriting the value of this register while sound is being generated 4 Ts after the key-on. (Rewriting within 4 Ts is disregarded.) When rewriting, specify the location of the header in the waveform data block in the LSAXH/L register. After the change, the address in this LSAXH/L register is used as a loop point, and the loop point information in the header of the waveform data is disregarded until the next time the voice is keyed on.

When decoding of the endpoint block is finished, regardless of the presence of the loop, the bit corresponding to the voice is set to 1 in the ENDX register and kept until the next key-on.

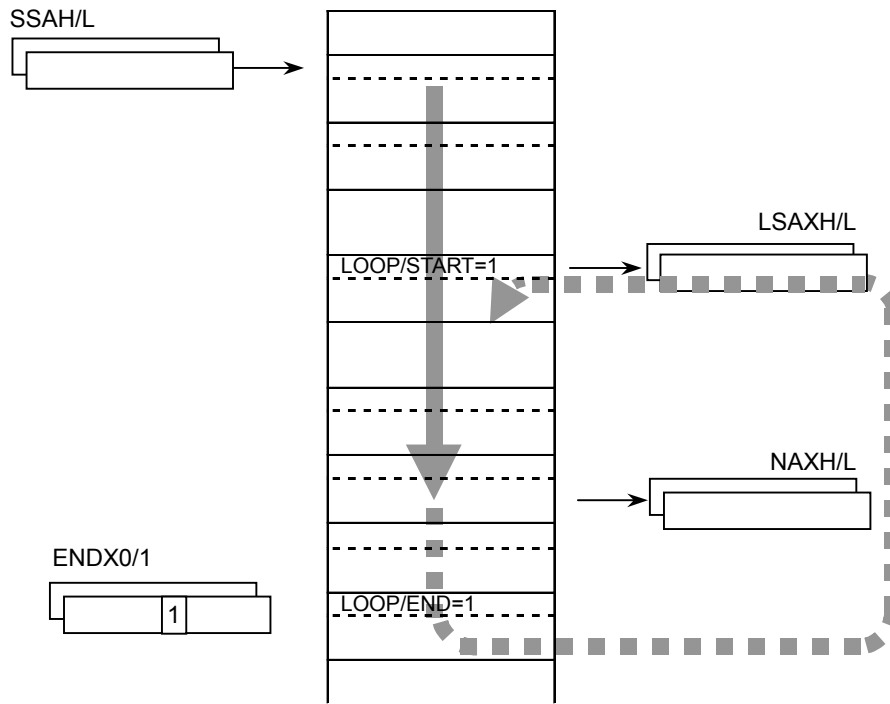

Figure 2-3 Sound Generation Status

2.1.2. Pitch Transformation

Sound can be generated from waveform data by varying the pitch within the range of -12 to +2 octaves. The pitch transformation is specified by the PITCH register of voice attribute.

Assuming the original pitch of the sound source is f_0 , the value of the PITCH register is [PITCH], and the finally generated sound is f , the following expression is met:

$$f = \frac{[PITCH]}{2^{12}} f_0$$

That is, sound is generated to the pitch of the original sound by specifying $0x1000(=2^{12})$ in the PITCH register.

The above relationship is met only when the waveform data is sampled at 48 kHz. The sound from waveform data sampled at a rate other than 48 kHz (24 kHz, for example) is generated one octave higher than the original sound when specifying $0x1000$ in the PITCH register to generate sound.

Assuming the sampling rate to be s kHz, the above-mentioned expression is expanded as follows.

$$f = \frac{48}{s} \frac{[PITCH]}{2^{12}} f_0$$

If an appropriate value is specified to the PITCH register according to this expression, sound can be generated to the pitch of the original sound even from the waveform data whose sampling rate is not 48 kHz. However, the acoustic characteristic varies along with pitch transformation processing.

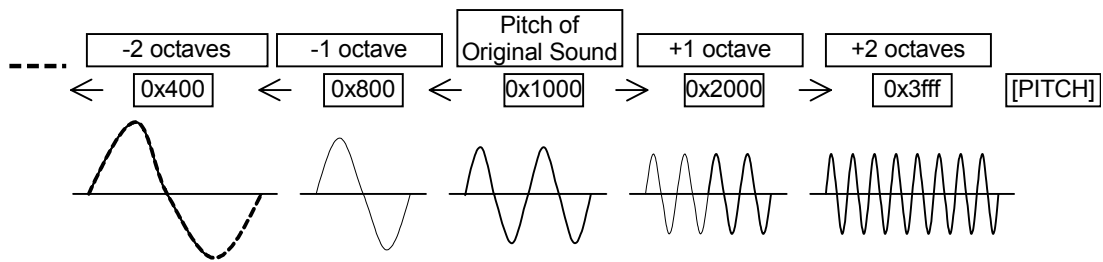

Figure 2-4 Pitch Transformation of Waveform Data Sampled at 48 kHz

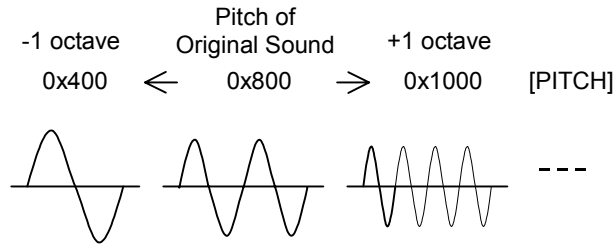

Figure 2-5 Pitch Transformation of Waveform Data Sampled at 24 kHz

When the sound source is the noise generator, the acoustic pitch can be specified in each core by using the sound library. When there are two or more voices allocated to the noise generator in each core, their sound will be all generated at the same acoustic pitch.

The speed of sound generation advance changes with the specification of the pitch. The lower the pitch is set, the slower the advance in the transition of the waveform data address shown by the NAXH/L register becomes.

2.1.3. Pitch Modulation

In two voices with consecutive voice numbers, voice n can be modulated by using the output value from voice n-1.

The value used for modulation is the product of the crest value immediately after decoding and the envelope value in the waveform data for voice n-1, which is 1Ts before in terms of time. This is called the OUTX of voice n-1. OUTX is not reflected in the register.

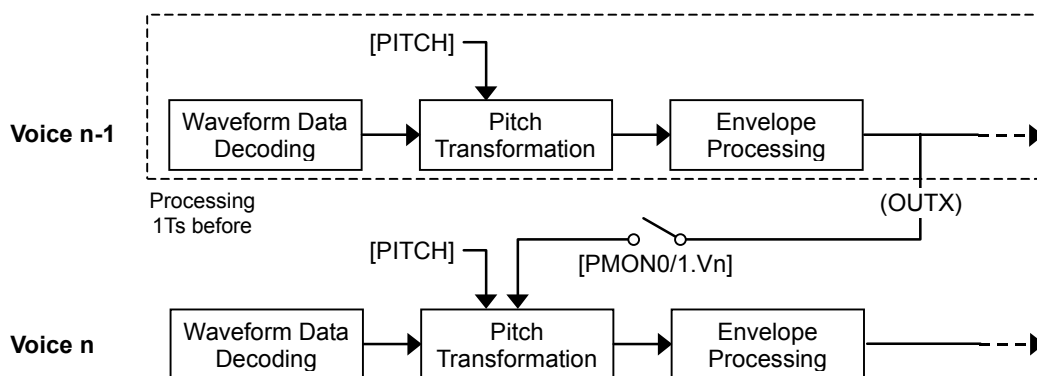

Figure 2-6 Pitch Modulation

Assuming the crest value of voice n-1 used for modulation of voice n to be OUTX and the pitch of voice n to be P, then P', the value to be used for pitch transformation of voice n, is decided by the following expression.

$$P' = P (1 + \text{OUTX})$$

Whether pitch modulation is performed or not can be specified with the PMON0/1 register. When not performed, the result becomes the same as the case for OUTX=0.

2.1.4. Envelope

The envelope specifies the volume variation by time from key-on to key-off according to the following five parameters.

Parameter	Code	Description
Attack Rate	AR	Rising immediately after key-on
Decay Rate	DR	Attenuation from the maximum value
Sustain Level	SL	Transition point from Decay to Sustain
Sustain Rate	SR	Attenuation (or increment) from Sustain Level to key-off
Release Rate	RR	Attenuation after key-off

For Attack Rate, Sustain Rate and Release Rate, curves of variation by time can be selected. Attack Rate and Release Rate can use two kinds and Sustain Rate can use four kinds of curves as shown in the table below. Decay Rate is fixed to an exponential decrement curve.

Parameter	Selection	Set Value
Attack Rate	Linear increment (+lin)	ADSR1.X=0
	Pseudo exponential increment (+exp)	ADSR1.X=1
Sustain Rate	Linear increment (+lin)	ADSR2.Y=000
	Linear decrement(-lin)	ADSR2.Y=010
	Pseudo exponential increment (+exp)	ADSR2.Y=100
	Exponential decrement (-exp)	ADSR2.Y=110
Release Rate	Linear decrement (-lin)	ADSR2.Z=0
	Exponential decrement (-exp)	ADSR2.Z=1

The "pseudo exponential increment" is a variation in line, in which linear volume increment is lowered in increment rate when 75% of the maximum value (0x6000) is exceeded.

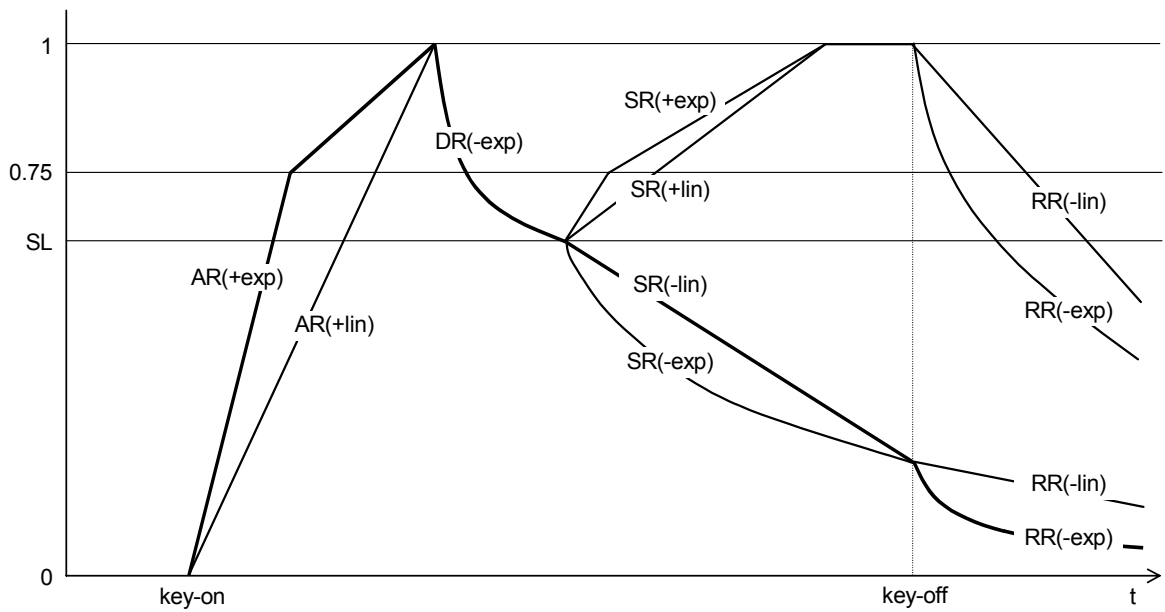

Figure 2-7 Parameters for Envelope and Their Curves

The value of the envelope varies successively, but the value is reflected in the ENVX register and can be referred to. When sound is generated from loop-less waveform data, ENVX is set to 0 regardless of the envelope status, at the moment the ENDX register bit corresponding to the voice is set to 1.

2.1.5. Volume

In each voice, the volume for the L channel and R channel can be set independently. By setting different values, the panpot can be configured.

The volume settings are made in the VOLL and VOLR registers.

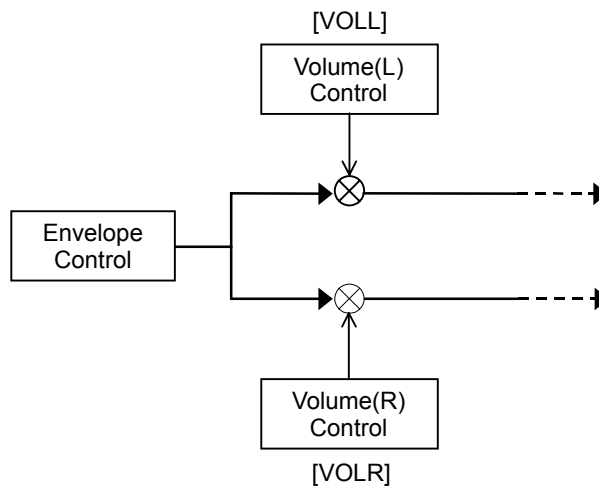

Figure 2-8 Volume Processing

The mode specification, by which the volume varies over time, can be set for the L channel and R channel independently, as in the case of the Sustain Rate of the envelope.

Mode	VOLL/R Register Setting	Volume Variation
Direct	Bit 15=0	Constant (No variation)
+lin	Bit 15:13=100	Linear increment
-lin	Bit 15:13=101	Linear decrement
+exp	Bit 15:13=110	Pseudo exponential increment
-exp	Bit 15:13=111	Exponential decrement

First specify the standard volume in direct mode and start sound generation, even when specifying a mode other than Direct mode. If a mode other than Direct mode is specified again later with a variation rate, variation of the volume starts instantly.

The phase can be reversed by setting a negative value in Direct mode.

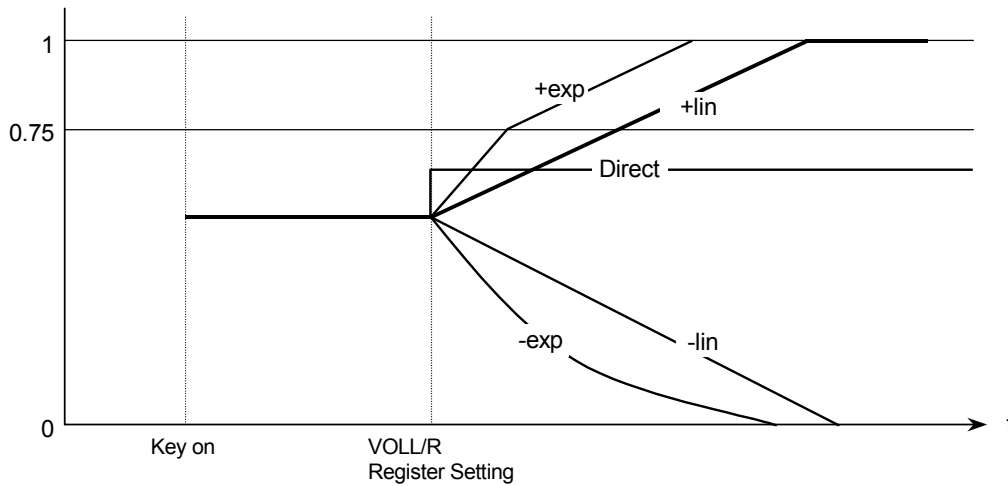

Figure 2-9 Volume Variation by Time

The volume varies successively in modes other than Direct mode, but the value is reflected in the VOLX register and can be referred to.

2.1.6. Key-On/Key-Off

Key-on (starting sound generation) and key-off (stopping sound generation) can be controlled by the KON0/1 and KOF0/1 registers, respectively, for each voice.

At key-on, sound generation of the waveform data indicated by the SSAH/L register is started according to the parameters of pitch, envelope, volume, etc.

At key-off, the envelope enters the Release phase and sound generation stops according to the Release Rate.

If there is no loop specification in the waveform data, sound generation of the voice ends when reaching the endpoint block of waveform data even before key-off, and muting is applied by hardware.

2.1.7. Mixing Switch

The output from each voice is mixed into four channels of Dry L, Wet L, Dry R and Wet R in each core through the control of the mixing switch.

For the mixing switch, on/off of each voice's output to the corresponding channels is specified in the VMIXL0/1, VMIXR0/1, VMIXEL0/1 and VMIXER0/1 registers. When a voice's output to all the channels is off, it is equivalent to a voice to which muting is applied.

The mixing results are successively stored in the local memory sound data output area, and become the final output from the core through switching by the MMIX register at the same time.

For the final output, on/off can be specified for Dry L, Wet L, Dry R and Wet R independently. Turning all the MMIX switches off is equivalent to applying muting to all the voice outputs.

Channel	Mixing Switch	Output Switch
Dry L (Voice direct output)	VMIXL0/1	MMIX.MSNDL
Dry R (Voice direct output)	VMIXR0/1	MMIX.MSNDR
Wet L (Voice effect output)	VMIXEL0/1	MMIX.MSNDL
Wet R (Voice effect output)	VMIXER0/1	MMIX.MSNDER

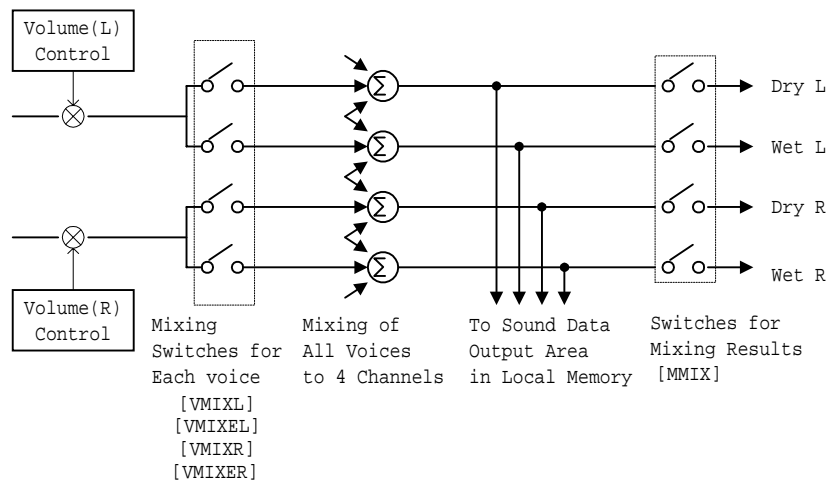

Figure 2-10 Voice Mixing

2.2. Sound Data Input Processing

Successive 16-bit data (little endian) transfer to the local memory sound data input area by the host enables the SPU2 to apply volume processing to the data as sound data, mix it with the output from voice processing, and then apply digital effects to it. It is also possible to output the sound data to the output block directly by bypassing the internal processing in the SPU2.

2.2.1. Sound Data Input Area

Each core is provided with one stereo unit as the sound data input. The addresses in the input area are as follows. These areas are reserved areas, and other data cannot be placed there.

Address	Area	Description
2000-21FF	CORE0 MEMIN(L)	CORE0 L channel sound data input area
2200-23FF	CORE0 MEMIN(R)	CORE0 R channel sound data input area
2400-25FF	CORE1 MEMIN(L)	CORE1 L channel sound data input area
2600-27FF	CORE1 MEMIN(R)	CORE1 R channel sound data input area

The sound data input area is 512 short words (1024 bytes) in size and is composed of double buffers of 256 short words.

Data transfer to the sound data input area can be realized easily by using the Auto DMA write transfer. For details, refer to the appropriate sound library document.

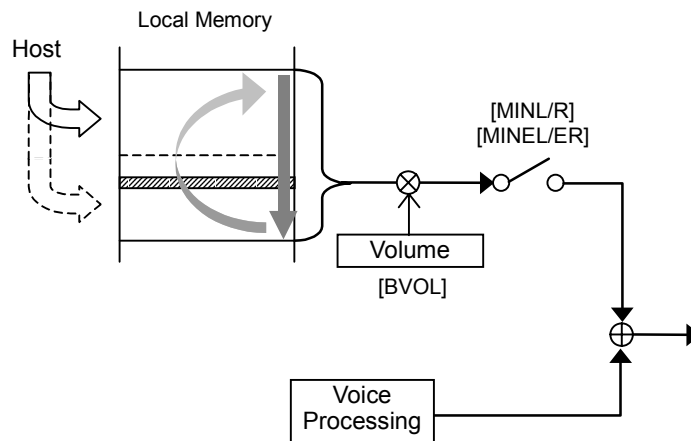

Figure 2-11 Sound Data Input

2.2.2. Volume Processing

The volume can be set to the sound obtained from the sound data input with the BVOLL and BVOLR registers. However, the mode of variation by time cannot be specified and the constant mode is always set.

2.2.3. Mixing with Voice Output

The sound obtained from the sound data input can be mixed with the Dry L/Wet L/Dry R/Wet R channel of the voice output. This is controlled by the flags of the MMIX register.

Sound Data Input	Voice Output	Switch
MEMIN(L)	Dry L	MMIX.MINL
MEMIN(R)	Dry R	MMIX.MINR
MEMIN(EL)	Wet L	MMIX.MINEL
MEMIN(ER)	Wet R	MMIX.MINER

2.2.4. Bypass Processing (CORE0)

It is possible to specify a mode that connects directly to the S/PDIF digital output of the output block by bypassing internal processing, for sound data input to CORE0. Since volume processing is not performed, the encoded data, which is not ordinary 16-bit digital data, can be directly output from the host.

In this mode, however, CORE1 output, the final output from the core, is not connected to the S/PDIF digital output. Moreover, this switching is performed only for the S/PDIF digital output and sound data input to CORE0 cannot be directly connected to the D/A converter output. For details, refer to the appropriate sound library document.

2.2.5. 32-bit Sound Data Input (CORE1)

It is possible to specify a mode that connects directly to the output block by bypassing the internal processing, for sound data input to CORE1. In this mode, the sound data input is processed in 32-bit units (24 bits enabled and lower 8 bits disabled). It can mix the 32-bit data (little endian) transferred from the host as higher quality digital data with the D/A converter output or the S/PDIF digital output.

The sound data input area is processed in 32-bit units in this mode. Since the unit of data volume doubles, the speed of data reading also doubles.

For details, refer to the appropriate sound library document.

2.2.6. Monaural Output

The SPU2 does not have the ability to generate monaural sound from the sound obtained from the sound data input. If monaural output is required, prepare monaural sound data at the authoring level.

2.3. Sound Data Output Processing

The SPU2 can write the generated 16-bit sound data to the local memory sound data output area at any time. Various processes can be applied to the sound data being generated by the SPU2 by reading the data successively on the host.

The contents of the sound data to be output and the output area are fixed as shown in the table. This area is a reserved area, and cannot be used for other purposes.

Core	Channel	Contents	Output Area
CORE0	Voice1	Crest value after multiplication of envelope in voice1	000400 – 0005FF
	Voice3	Crest value after multiplication of envelope in voice3	000600 – 0007FF
	MEMOUT(L)	Dry L after mixing 24 voices	001000 – 0011FF
	MEMOUT(R)	Dry R after mixing 24 voices	001200 – 0013FF
	MEMOUT(EL)	Wet L after mixing 24 voices	001400 – 0015FF
	MEMOUT(ER)	Wet R after mixing 24 voices	001600 – 0017FF
CORE1	SIN(L)	CORE0 output L	000800 – 0009FF
	SIN(R)	CORE0 output R	000A00 – 000BFF
	Voice1	Crest value after multiplication of envelope in voice1	000C00 – 000DFF
	Voice3	Crest value after multiplication of envelope in voice3	000E00 – 000FFF
	MEMOUT(L)	Dry L after mixing 24 voices	001800 – 0019FF
	MEMOUT(R)	Dry R after mixing 24 voices	001A00 – 001BFF
	MEMOUT(EL)	Wet L after mixing 24 voices	001C00 – 001DFF
	MEMOUT(ER)	Wet R after mixing 24 voices	001E00 – 001FFF

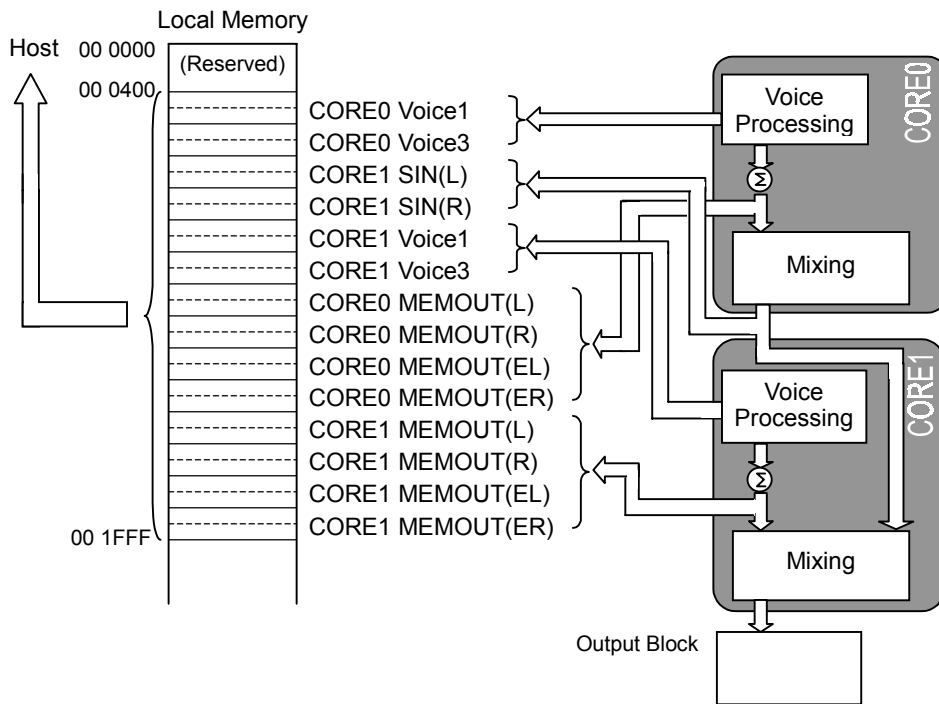

Figure 2-12 Sound Data Output

The output area is 512 short words (1024 bytes) in size for each channel, and is composed of double buffers of 256 short words each.

Data can be read easily from the sound data output area by using the Auto DMA read transfer. For details, refer to the appropriate sound library document.

2.4. Mixing

Mixing performs volume processing and switching to voice output, sound data input and external input, and distributes the data to direct output and digital effects.

Each core has the following four sources:

Source	Volume	Switch	Destination
Voice Direct Output (Dry L/R)	-	MMIX.MSNDL/R	Direct Output
Voice Effect Output (Wet L/R)	-	MMIX.MSNDEL/ER	Digital Effect
Sound Data Input	BVOLL/R	MMIX.MINL/R	Direct Output
		MMIX.MINEL/ER	Digital Effect
External Input (Final Output from CORE0)	AVOLL/R	MMIX.SINL/R	Direct Output
		MMIX.SINEL/ER	Digital Effect

* External input is performed only to CORE1.

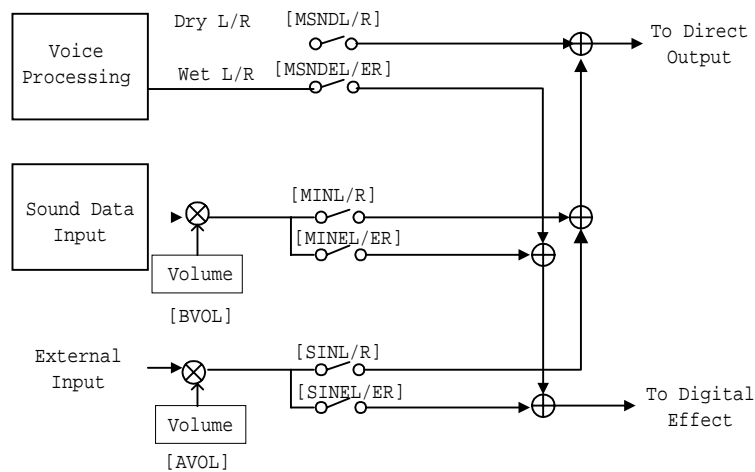

Figure 2-13 Mixing

For sound data input and external input, only the constant mode is set for volume variation with time.

2.5. Digital Effect Processing

Various sound effects such as reverb, echo and delay can be added by performing digital effect processing on the sounds generated by each core and input from the sound data input.

For other digital effect procedures, refer to the sound library document.

2.5.1. Signal Flow for Digital Effect Processing

The input to digital effect processing is the mixture of the following sound sources as described in "2.4. Mixing".

- Voice Effect Output (Wet L/R)
- Sound Data Input
- External Input *CORE1 only

However, various connection forms can be taken by passing through the host with switch on/off setting and sound data output function.

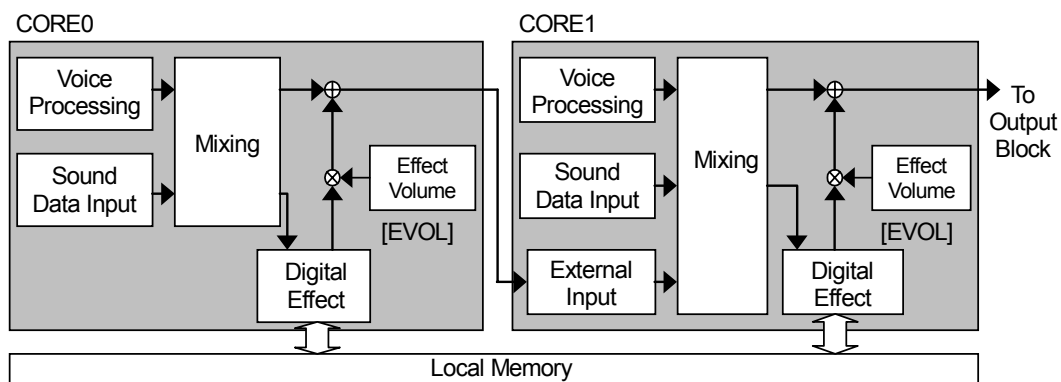

Figure 2-14 Signal Flow of Digital Effects

2.5.2. Work Area for Digital Effect Processing

When performing digital effect processing, it is necessary to reserve a work area in the local memory.

The start address of the work area is specified with the ESAH/L register and the end address is specified with the EEAH register.

Decide the start address by totaling the size required by each delay block for digital effects.

The end address is specified in the upper 6 bits only, and it is assumed that the lower 16 bits are 0xFFFF. That is, the end address in the work area is always on a 64K short-word (128 KB) boundary in the local memory.

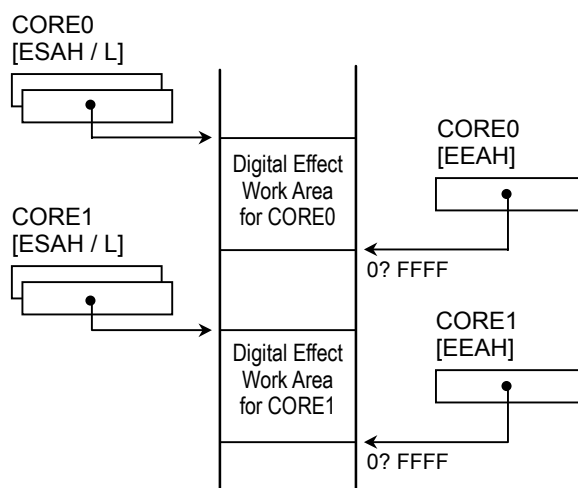

Figure 2-15 Work Area for Digital Effects

2.5.3. Effect Volume

When the output from a digital effect is mixed with the direct output, volume control can be performed to the output from the digital effect.

The effect volume is set with the EVOLL/R register. The panpot of the effect can be decided by setting the L channel and R channel independently. Only the constant mode is set for the variation with time.

The volume set by the EVOLL/R register corresponds to the return volume of the effect. The following volume settings of each source correspond to the send volume respectively.

Source	Send Volume	Remarks
Voice Output	VOLL/R	
Sound Data Input	BVOLL/R	
External Input	AVOLL/R	CORE1 only

2.6. Master Volume

The final volume is determined by adding the master volume to the mixing result of the output from the digital effect and direct output (Dry L/R). The master volume of the L channel and R channel can be set independently by the MVOLL and MVOLR register. By setting the values, the whole panpot is decided.

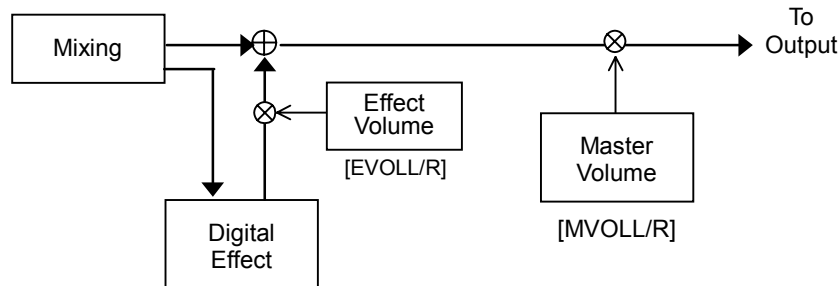

Figure 2-16 Master Volume Processing

The mode of varying the master volume with time can be specified as follows, as well as the voice volume:

Mode	MVOLL/R Register Setting	Volume Variation
Direct	Bit 15=0	Constant (no variation with time)
+lin	Bit 15:13=100	Linear increment
-lin	Bit 15:13=101	Linear decrement
+exp	Bit 15:13=110	Pseudo exponential increment
-exp	Bit 15:13=111	Exponential decrement

The L channel and R channel can be specified independently for the volume mode as well.

When specifying a mode other than "Direct", first specify the standard volume value in Direct mode. Then, the volume variation starts when other volume mode variation rates are re-specified. Moreover, the phase can be reversed by specifying a negative value as a variation rate.

The current value of the master volume can be read from the MVOLXL/MVOLXR register.

2.7. Interrupt Processing

In most SPU2 processing, when each core accesses a specific address in the local memory, an interrupt can be generated to the host. The address where an interrupt is generated is set by the IRQAH and IRQAL registers.

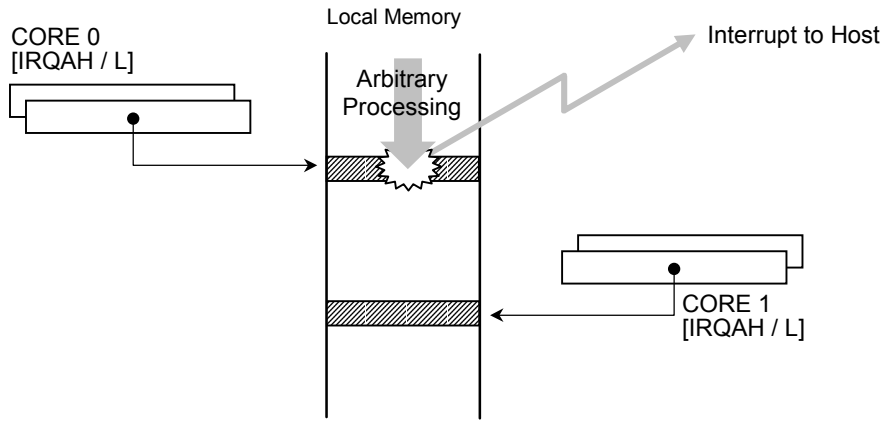

Figure 2-17 Interrupt Processing

No matter which core accesses this address, an interrupt is generated. Interrupts generated by both cores are detected at the same time on the host. An interface provided by the sound library represents which core has generated the interrupt.

In the following situations, there are limitations and warnings applied to the relationship between each core's access and interrupts.

Initial state and waveform data without a loop

Voices without key-on after resetting the SPU2, and voices generated after decoding the LOOP/END block of loop-less waveform data, access the local memory unnecessarily (free-run the entire local memory area) as an internal operation of the SPU2. This may cause an unexpected interrupt.

Therefore, when applying an interrupt to loop-less waveform data, suppress unnecessary accesses from a voice not in process, by adding a soundless block whose LOOP/START, LOOP, and LOOP/END bits are set to 1 to the end of the data. (For waveform data format, refer to "1.3. Waveform Data Format".) Actions for the voices to which key-on has not been applied after resetting are handled via the sound library.

Position of waveform data which sets interrupt generation address

If an address between the starting and end addresses in waveform data is specified to the SSAH/L or LSAXH/L register by mistake and the IRQA/H register is specified to the same address, an interrupt does not occur.

Local memory data transfer

When local memory data transfer is performed, the internal pointer stays at the following addresses at the end of the transfer:

Transfer from host to local memory: TSAH/L + Data Size + 1

Transfer from local memory to host: TSAH/L + Data Size + 0 x 20

(Both are in short-word units)

Therefore, if the IRQAH/L register has been set at these positions, an interrupt occurs after the transfer has been ended.

Digital effect processing

When digital effect processing is disabled, interrupts by digital effect processing are not generated even if the interrupt generation address is specified to the digital effect work area.

(This page is left blank intentionally)

3. Register List

3.1. Classification of Registers

The registers of the SPU2 are classified as follows:

Voice basic parameter registers

These registers show the basic parameters of each voice. Each voice in each core has a set of registers.

Voice control parameter registers

These registers control on/off of each function in voice processing. Each core has a set of registers.

Addressing registers

These registers perform address specification in the local memory. The registers, which show the upper 6 bits and the lower 16 bits in the address, are paired. Each core has a set of registers.

Digital effect addressing registers

These registers perform addressing related to digital effects. The registers, which show the upper 6 bits and the lower 16 bits in the address, are paired. Each core has a set of registers.

Volume registers

These registers specify the mixing volume of each voice. Each core has a set of registers.

3.2. Registers in Pairs

The SPU2 registers include registers to be used in pairs.

Addresses in the local memory are specified by a pair of registers showing the upper 6 bits and the lower 16 bits of one address. For example, the starting address of the waveform data for each voice is maintained in the SSAH register (the upper 6 bits) and the SSAL register (the lower 16 bits). Therefore, SSAH and SSAL are treated as a pair and written as the SSAH/L register.

The EEAH register is an exception to the addressing registers, and does not include a register which shows the lower 16 bits.

Registers that specify the switching for each voice are composed of a pair of registers corresponding to Voice 0-15 and Voice 16-23. As for the specification of the voice output to the Dry L channel, for example, Voice0-15 and Voice16-23 are specified by the VMIXL0 register and VMIXL1 register respectively. These two registers are treated as a pair and written as the VMIXL0/1 register.

VOLL / VOLR : Voice volume

Constant specification mode (direct mode)

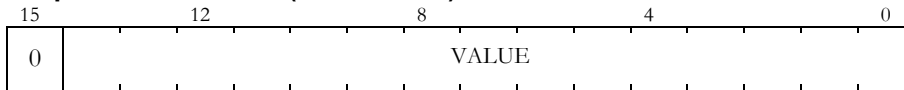

Name	Pos.	Format	Contents
VALUE	14:0	int 1:0:14	Constant volume value The phase reverses for a negative value.

Linear increment mode (+lin mode)

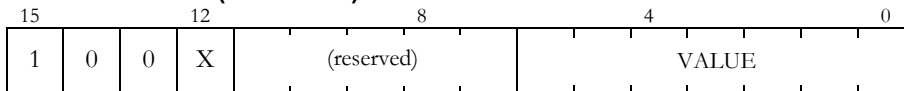

Name	Pos.	Format	Contents
VALUE	6:0	int 0:7:0	Addition constant per Ts
X	12	int 0:1:0	Polarity specification 0 Normal phase (specifiable when the current value is positive.) Linear increment to +1.0 1 Reverse phase (specifiable when the current value is negative.) Linear decrement to -1.0

Linear decrement mode (-lin mode)

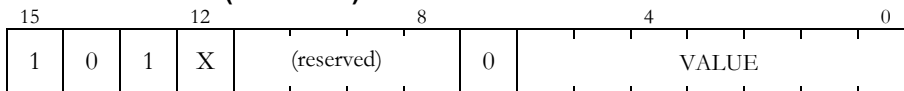

Name	Pos.	Format	Contents
VALUE	6:0	int 0:7:0	Subtraction constant per Ts
X	12	int 0:1:0	Polarity specification 0 Normal phase (specifiable when the current value is positive.) Linear decrement to 0 1 Reverse phase (specifiable when the current value is negative.) Linear increment to 0

Pseudo inverse-exponential increment mode (+exp mode)

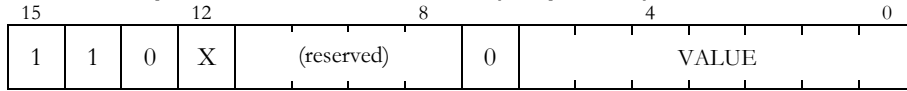

Name	Pos.	Format	Contents
VALUE	6:0	int 0:7:0	Addition constant per Ts
X	12	int 0:1:0	Polarity specification 0 Normal phase (specifiable when the current value is positive.) Increment to +1.0 in a line 1 Reverse phase (specifiable when the current value is negative.) Decrement to -1.0 in a line

Exponential decrement mode (-exp mode)

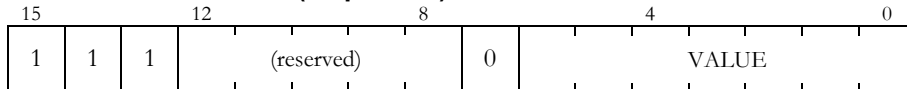

Name	Pos.	Format	Contents
VALUE	6:0	int 0:7:0	Multiplication constant per Ts

Description

These registers specify the volume for each voice.

The values of the upper three bits specify the pattern of the volume variation with time. When specifying a mode other than constant mode, the volume value varies with time, because the value corresponding to the value of the VALUE field is added to, subtracted from or multiplied by the volume value per Ts.

For the relationship between the VALUE field value and actual volume duration, refer to "4.1. Rate Parameter Table".

PITCH : Pitch when sound is generated

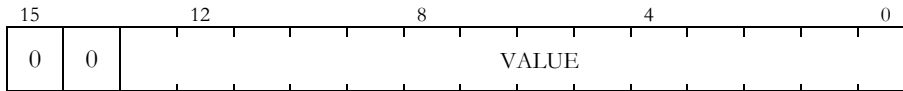

Name	Pos.	Format	Contents
VALUE	13:0	int 0:14:0	Pitch specification value

Description

This register specifies the pitch (degree of highness or lowness of sound) of each voice.

Assuming the pitch of the original sound (waveform data) to be f_0 , the relationship between the VALUE, or the pitch specification, and the pitch f , from which sound is generated, is as follows:

$$f = \frac{\text{VALUE}}{4096} f_0$$

When the sound source is a noise generator, there is no acoustic variation even though the pitch specification is changed. The pitch of the noise can be specified for each core by using the sound library.

Notes

Pitch specification affects the progressing speed of sound generation. The lower the pitch is specified, the slower the sound generation proceeds.

ADSR1 / ADSR2 : Envelope

ADSR1

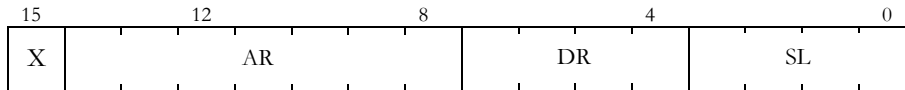

Name	Pos.	Format	Contents
SL	3:0	int 0:4:0	Sustain Level
DR	7:4	int 0:4:0	Decay Rate
AR	14:8	int 0:7:0	Attack Rate
X	15	int 0:1:0	Mode specification for Attack Rate 0 Linear increment mode (+lin mode) 1 Pseudo exponential increment mode (+exp mode)

ADSR2

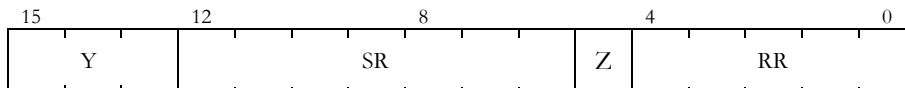

Name	Pos.	Format	Contents
RR	4:0	int 0:5:0	Release Rate
Z	5	int 0:1:0	Mode specification for Release Rate 0 Linear decrement mode (-lin mode) 1 Exponential decrement mode (-exp mode)
SR	12:6	int 0:7:0	Sustain Rate
Y	15:13	int 0:3:0	Mode specification for Sustain Rate 000 Linear increment mode (+lin mode) 010 Linear decrement mode (-lin mode) 100 Pseudo exponential increment mode (+exp mode) 110 Exponential decrement mode (-exp mode)

Description

These registers specify each parameter for the envelope.

For the relationship between the Rate/Level field values and actual envelope duration, refer to "4.1. Rate Parameter Table".

ENVX : Current value of envelope

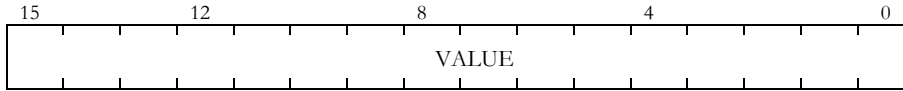

Name	Pos.	Format	Contents
VALUE	15:0	int 1:0:15	Current value of envelope

Description

This register indicates the current value of the envelope.

When SR and RR for the envelope specify linear decrement, a negative value is set only for 1 Ts.

When sound is generated from loop-less waveform data, ENVX is set to 0 regardless of the envelope status, at the moment the ENDX register bit corresponding to the voice is set to 1.

VOLXL / VOLXR : Current value of volume

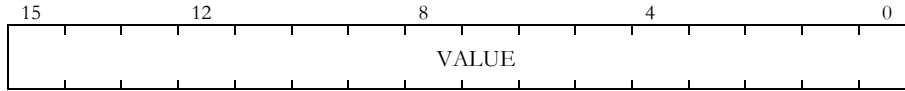

Name	Pos.	Format	Contents
VALUE	15:0	int 1:0:15	Current value of voice volume

Description

These registers indicate the current volume of each voice.

When VOL is in a mode other than constant specification mode, the value varies per Ts according to the volume variation.

PMON0 / PMON1 : Pitch modulation specification

PMON0

15	12	8	4	0											
V	V	V	V	V	V	V	V	V	V	V	V	V	V	V	-
15	14	13	12	11	10	9	8	7	6	5	4	3	2	1	-

Name	Pos.	Format	Contents
V1	1	int 0:1:0	Pitch modulation specification for Voice1 0 Pitch modulation off 1 Pitch modulation by Voice0 output
(Omitted)			
V15	15	int 0:1:0	Pitch modulation specification for Voice15 0 Pitch modulation off 1 Pitch modulation by Voice14 output

PMON1

15	12	8	4	0										
(reserved)							V	V	V	V	V	V	V	V
							23	22	21	20	19	18	17	16

Name	Pos.	Format	Contents
V16	0	int 0:1:0	Pitch modulation specification for Voice16 0 Pitch modulation off 1 Pitch modulation by Voice15 output
(Omitted)			
V23	7	int 0:1:0	Pitch modulation specification for Voice23 0 Pitch modulation off 1 Pitch modulation by Voice22 output

Description

These registers specify whether to apply the pitch modulation to each voice by using the crest value of the voice of a number lower.

Voice0 is disabled.

NON0 / NON1 : Voice allocation to noise generator

NON0

15	12	8	4	0											
V	V	V	V	V	V	V	V	V	V	V	V	V	V	V	
15	14	13	12	11	10	9	8	7	6	5	4	3	2	1	0

Name	Pos.	Format	Contents
V0	0	int 0:1:0	Sound source specification for Voice0 0 Waveform data 1 Noise generator
(Omitted)			
V15	15	int 0:1:0	Sound source specification for Voice15 0 Waveform data 1 Noise generator

NON1

15	12	8	4	0										
(reserved)							V	V	V	V	V	V	V	V
							23	22	21	20	19	18	17	16

Name	Pos.	Format	Contents
V16	0	int 0:1:0	Sound source specification for Voice16 0 Waveform data 1 Noise generator
(Omitted)			
V23	7	int 0:1:0	Sound source specification for Voice23 0 Waveform data 1 Noise generator

Description

These registers specify whether to allocate each voice to the noise generator as a sound source.

VMIX* : Mixing specification of voice output

VMIXL0, VMIXEL0, VMIXR0, VMIXER0

15	12	8	4	0											
V	V	V	V	V	V	V	V	V	V	V	V	V	V	V	
15	14	13	12	11	10	9	8	7	6	5	4	3	2	1	0

Name	Pos.	Format	Contents
V0	0	int 0:1:0	Output switch for Voice0 0 No output to applicable channel. 1 Output to applicable channel.
(Omitted)			
V15	15	int 0:1:0	Output switch for Voice15 0 No output to applicable channel. 1 Output to applicable channel.

VMIXL1, VMIXEL1, VMIXR1, VMIXER1

15	12	8	4	0										
(reserved)							V	V	V	V	V	V	V	V
							23	22	21	20	19	18	17	16

Name	Pos.	Format	Contents
V16	0	int 0:1:0	Output switch for Voice16 0 No output to applicable channel. 1 Output to applicable channel.
(Omitted)			
V23	7	int 0:1:0	Output switch for Voice23 0 No output to applicable channel. 1 Output to applicable channel.

Description

These registers specify whether to output the output from each voice to each channel of Dry L/Wet L/Dry R/Wet R. Each register corresponds to each channel as shown below.

Register	Channel
VMIXL0	Dry L (Direct output (L))
VMIXL1	Dry L (Direct output (L))
VMIXEL0	Wet L (Effect output (L))
VMIXEL1	Wet L (Effect output (L))
VMIXR0	Dry R (Direct output (R))
VMIXR1	Dry R (Direct output (R))
VMIXER0	Wet R (Effect output (R))
VMIXER1	Wet R (Effect output (R))

IRQAH / IRQAL : Interrupt address specification

IRQAH



Name	Pos.	Format	Contents
ADDRH	5:0	int 0:6:0	Local memory address where an interrupt is generated (upper 6 bits)

IRQAL



Name	Pos.	Format	Contents
ADDRL	15:0	int 0:16:0	Local memory address where an interrupt is generated (lower 16 bits)

Description

When each core accesses a specific address in the local memory, an interrupt can be generated for the host. The above registers specify the address. For details, refer to "2.7. Interrupt Processing".

KON0 / KON1 : Key-on specification

KON0

15	12	8	4	0											
V	V	V	V	V	V	V	V	V	V	V	V	V	V	V	
15	14	13	12	11	10	9	8	7	6	5	4	3	2	1	0

Name	Pos.	Format	Contents
V0	0	int 0:1:0	Key-on switch of Voice0
(Omitted)			
V15	15	int 0:1:0	Key-on switch of Voice15

KON1

15	12	8	4	0										
(reserved)							V	V	V	V	V	V	V	V
							23	22	21	20	19	18	17	16

Name	Pos.	Format	Contents
V16	0	int 0:1:0	Key-on switch of Voice16
(Omitted)			
V23	7	int 0:1:0	Key-on switch of Voice23

Description

These registers specify key-on (start of sound generation) of each voice. When writing these registers, the sound generation of the voice, which corresponds to the bit set to 1 among the written values, is started.

Notes

- The value read from this register does not reflect the voice that has actually been generated.
- Do not write to any bits of the same register (KON0 or KON1) twice within 2 Ts. The period of time between commands may not be sufficient for the commands to execute properly.
- Do not specify key-on and key-off of the same voice within 2 Ts. If specified, the voice which actually starts / ends sound generation is indeterminate.
- Key-on can be specified for the voice in the process of sound generation, by writing 1 to the bit again without specifying key-off.

KOF0 / KOF1 : Key-off specification

KOF0

15	12	8	4	0											
V	V	V	V	V	V	V	V	V	V	V	V	V	V	V	
15	14	13	12	11	10	9	8	7	6	5	4	3	2	1	0

Name	Pos.	Format	Contents
V0	0	int 0:1:0	Key-off switch of Voice0
(Omitted)			
V15	15	int 0:1:0	Key-off switch of Voice15

KOF1

15	12	8	4	0										
(reserved)							V	V	V	V	V	V	V	V
							23	22	21	20	19	18	17	16

Name	Pos.	Format	Contents
V16	0	int 0:1:0	Key-off switch of Voice16
(Omitted)			
V23	7	int 0:1:0	Key-off switch of Voice23

Description

These registers specify key-off (end of sound generation) of each voice. When writing these registers, the envelope of the voice, which corresponds to the bit set to 1 among the written values, goes to the release phase.

Notes

Do not write to any bits of the same register (KOF0 or KOF1) twice within 2 Ts. The period of time between commands may not be sufficient for the commands to execute properly.

Do not specify key-on and key-off of the same voice within 2 Ts. If specified, the voice which actually starts / ends sound generation is indeterminate.

TSAH / TSAL : Transfer start address

TSAH

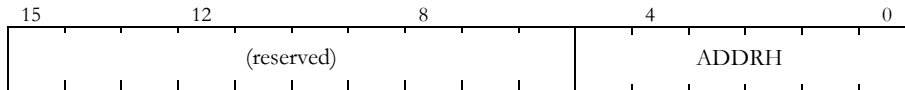

Name	Pos.	Format	Contents
ADDRH	5:0	int 0:6:0	The starting address of the transfer area in the local memory (upper 6 bits)

TSAL

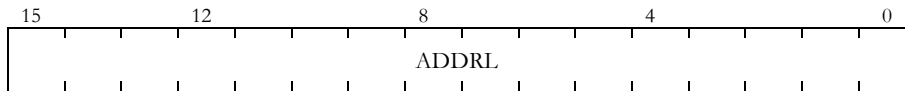

Name	Pos.	Format	Contents
ADDRL	15:0	int 0:16:0	The starting address of the transfer area in the local memory (lower 16 bits)

Description

These registers specify the starting address in the local memory area, which becomes the source/destination in DMA read transfer, DMA write transfer, Auto DMA read transfer and single write transfer.

In the SSAL, which specifies the starting address of the waveform data (lower 16 bits) to the voice, the lower 3 bits must be specified to 0 when transferring the waveform data to the local memory. Therefore, in the case of the TSAL, it is also necessary to transfer data to the address whose lower 3 bits are set to 0.

Notes

The value is invariant regardless of the transfer execution status.

If the value is changed during data transfer, operation and transferred data become indeterminate.

SSAH / SSAL : Starting address of waveform data

SSAH

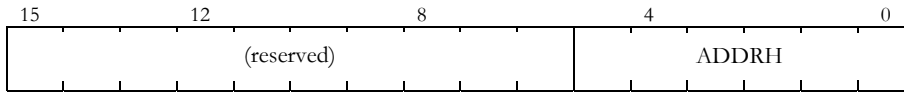

Name	Pos.	Format	Contents
ADDRH	5:0	int 0:6:0	Starting address of waveform data (upper 6 bits)

SSAL

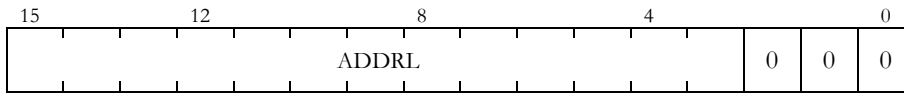

Name	Pos.	Format	Contents
ADDRL	15:0	int 0:16:0	Starting address of waveform data (lower 16 bits; 0 is specified to lower 3 bits)

Description

These registers specify the starting address of the waveform data, which becomes the sound source of each voice.

LSAXH / LSAXL : Address of loop point

LSAXH

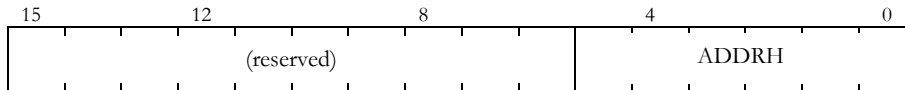

Name	Pos.	Format	Contents
ADDRH	5:0	int 0:6:0	Loop point address (upper 6 bits)

LSAXL

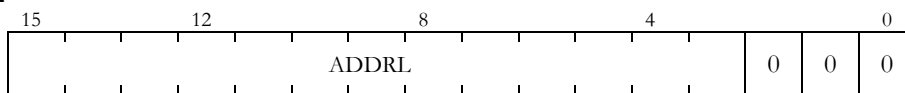

Name	Pos.	Format	Contents
ADDRL	15:0	int 0:16:0	Loop point address (lower 16 bits; when writing, 0 is specified to lower 3 bits)

Description

These registers show the starting address of the block specified as a loop point (the block whose LOOP/START bit of the header is set to 1) in the waveform data. These are set when the loop point block is passed through with the advance of sound generation.

The loop point can be set or changed by writing the address of an appropriate block header to this register during sound generation (4 Ts after the key-on). (Rewriting within 4 Ts is disregarded.) In this case, the loop point specification of the waveform data is disregarded temporarily until the next time the voice is keyed on.

NAXH / NAXL : Address of waveform data to be read next

NAXH

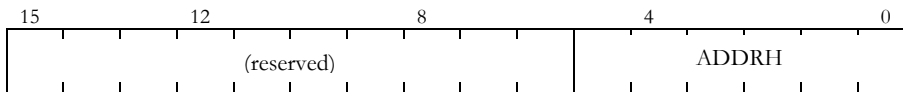

Name	Pos.	Format	Contents
ADDRH	5:0	int 0:6:0	Address of the waveform data to be read next (upper 6 bits)

NAXL

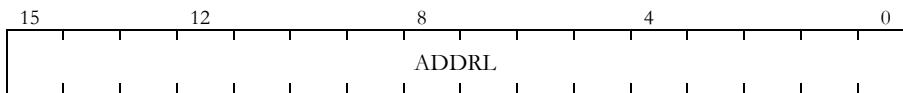

Name	Pos.	Format	Contents
ADDRL	15:0	int 0:16:0	Address of the waveform data to be read next (lower 16 bits)

Description

These registers show the address of the waveform data to be read next. They are updated automatically with the advance of sound generation.

ESAH / ESAL : Starting address in the work area for effect processing

ESAH

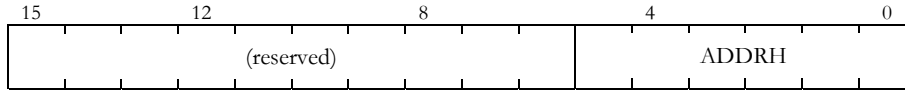

Name	Pos.	Format	Contents
ADDRH	5:0	int 0:6:0	Starting address in the work area for effect (upper 6 bits)

ESAL

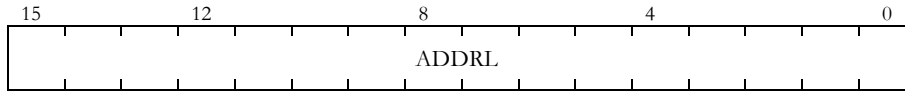

Name	Pos.	Format	Contents
ADDRL	15:0	int 0:16:0	Starting address in the work area for effect (lower 16 bits)

Description

These registers specify the starting address in the work area to be used for digital effect processing.

EEAH : End address in the work area for effect processing

EEAH

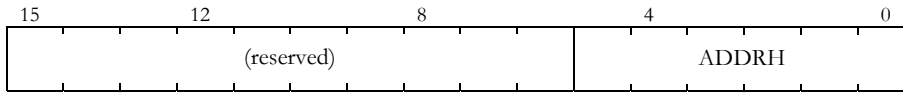

Name	Pos.	Format	Contents
ADDRH	5:0	int 0:6:0	End address in the work area for effect processing (upper 6 bits)

Description

This register specifies the end address in the work area to be used for digital effect processing. Unlike other addressing registers, this register, which specifies the upper 6 bits only, is not paired with a register, which specifies the lower 16 bits. Because of this, the end address in the work area can only be specified on the 64K short-word (128 KB) boundary.

ENDX0 / ENDX1 : Endpoint passing flag

ENDX0

15	12	8	4	0											
V	V	V	V	V	V	V	V	V	V	V	V	V	V	V	
15	14	13	12	11	10	9	8	7	6	5	4	3	2	1	0

Name	Pos.	Format	Contents
V0	0	int 0:1:0	Endpoint passing flag for Voice0 0 Has not been passed. 1 Has been passed.
(Omitted)			
V15	15	int 0:1:0	Endpoint passing flag for Voice15 0 Has not been passed. 1 Has been passed.

ENDX1

15	12	8	4	0										
(reserved)							V	V	V	V	V	V	V	V
							23	22	21	20	19	18	17	16

Name	Pos.	Format	Contents
V16	0	int 0:1:0	Endpoint passing flag for Voice16 0 Has not been passed. 1 Has been passed.
(Omitted)			
V23	7	int 0:1:0	Endpoint passing flag for Voice23 0 Has not been passed. 1 Has been passed.

Description

These registers show whether or not the endpoint block has been reached with the advance of sound generation of each voice.

The bit corresponding to the voice is set to 0 by specifying key-on.

All the bits are cleared to 0 by writing an arbitrary value (including a value other than 0) to these registers.

MVOLL / MVOLR : Master volume

Constant specification mode (direct mode)

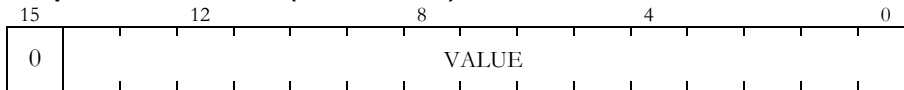

Name	Pos.	Format	Contents
VALUE	14:0	int 1:0:14	Volume value The phase reverses for a negative value.

Linear increment mode (+lin mode)

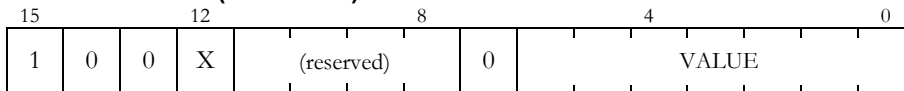

Name	Pos.	Format	Contents
VALUE	6:0	int 0:7:0	Addition constant per Ts
X	12	int 0:1:0	Polarity specification 0 Normal phase (specifiable when the current value is positive.) Linear increment to +1.0 1 Reverse phase (specifiable when the current value is negative.) Linear decrement to -1.0

Linear decrement mode (-lin mode)

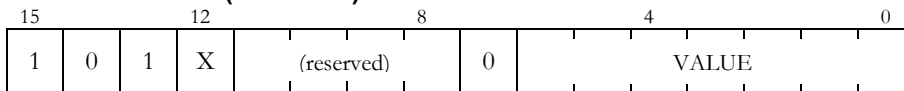

Name	Pos.	Format	Contents
VALUE	6:0	int 0:7:0	Subtraction constant per Ts
X	12	int 0:1:0	Polarity specification 0 Normal phase (specifiable when the current value is positive.) Linear decrement to 0 1 Reverse phase (specifiable when the current value is negative.) Linear increment to 0

Pseudo inverse-exponential increment mode (+exp mode)

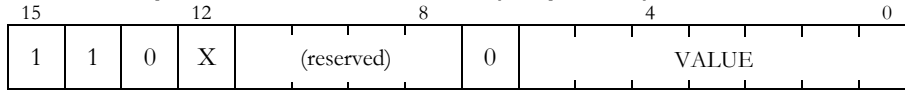

Name	Pos.	Format	Contents
VALUE	6:0	int 0:7:0	Addition constant per Ts
X	12	int 0:1:0	Polarity specification 0 Normal phase (specifiable when the current value is positive.) Increment to +1.0 in a line. 1 Reverse phase (specifiable when the current value is negative.) Decrement to -1.0 in a line.

Exponential decrement mode (-exp mode)

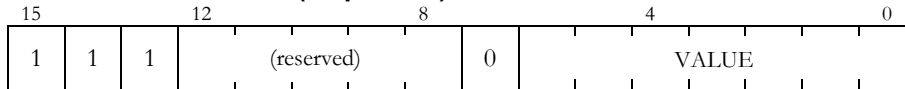

Name	Pos.	Format	Contents
VALUE	6:0	int 0:7:0	Multiplication constant

Description

These registers specify the master volume for each core.

The values of the upper three bits specify the pattern of the volume variation with time. When specifying a mode excluding the constant mode, the master volume value varies with time, because the value corresponding to the value of the VALUE field is added to, subtracted from or multiplied by the master volume value per Ts.

For the relationship between the VALUE field value and actual volume duration, refer to "4.1. Rate Parameter Table".

EVOLL / EVOLR : Return volume of effect

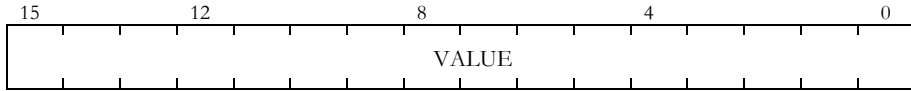

Name	Pos.	Format	Contents
VALUE	15:0	int 1:0:15	Return volume of effect The phase reverses for a negative value.

Description

These registers specify the volume when mixing the output from digital effect processing with the Dry L/Dry R channel.

AVOLL / AVOLR : Volume for external input

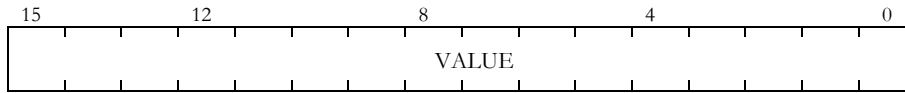

Name	Pos.	Format	Contents
VALUE	15:0	int 1:0:15	Volume for external input The phase reverses for a negative value.

Description

These registers specify the volume for the external input.
They are disabled in CORE0.

BVOLL / BVOLR : Volume for sound data input

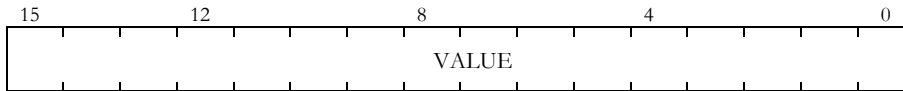

Name	Pos.	Format	Contents
VALUE	15:0	int 1:0:15	Volume for sound data input The phase reverses for a negative value.

Description

These registers specify the volume for sound data input.

MVOLXL / MVOLXR : Current value of master volume

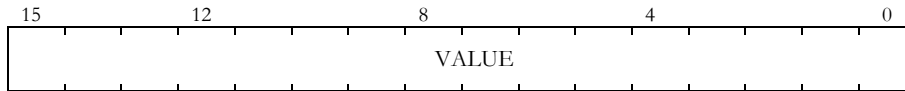

Name	Pos.	Format	Contents
VALUE	15:0	int 1:0:15	Current value of master volume

Description

These registers indicate the current value of the master volume.

When MVOL is in a mode other than constant specification mode, the value varies per Ts according to the volume variation.

(This page is left blank intentionally)

4. Appendix

4.1. Rate Parameter Table

The following tables show the volume variation rate for values of the envelope rate/level parameters (AR, DR, SL, SR and RR) and the parameters to specify volume variation with time. The variation rate is shown with the time required for the volume to vary from 0 to 1 (1 to 0, or 1 to 0.1). For SL, the variation rate is shown with level.

4.1.1. +Lin Mode

The variation is shown in linear increment for normal phase and in linear decrement for reverse phase.

Set Value	0 -> 1 Time
000 0000	0.05 (msec)
000 0001	0.06
000 0010	0.07
000 0011	0.09
000 0100	0.10
000 0101	0.12
000 0110	0.15
000 0111	0.18
000 1000	0.21
000 1001	0.24
000 1010	0.29
000 1011	0.36
000 1100	0.41
000 1101	0.48
000 1110	0.58
000 1111	0.73
001 0000	0.83
001 0001	0.97
001 0010	1.2
001 0011	1.5
001 0100	1.7
001 0101	1.9
001 0110	2.3
001 0111	2.9
001 1000	3.3
001 1001	3.9
001 1010	4.6
001 1011	5.8
001 1100	6.6
001 1101	7.7
001 1110	9.3
001 1111	12
010 0000	13
010 0001	15
010 0010	19
010 0011	23
010 0100	27
010 0101	31
010 0110	37

Set Value	0 -> 1 Time
010 0111	46 (msec)
010 1000	53
010 1001	62
010 1010	74
010 1011	93
010 1100	0.11 (sec)
010 1101	0.12
010 1110	0.15
010 1111	0.19
011 0000	0.21
011 0001	0.25
011 0010	0.30
011 0011	0.37
011 0100	0.42
011 0101	0.50
011 0110	0.59
011 0111	0.74
011 1000	0.85
011 1001	0.99
011 1010	1.2
011 1011	1.5
011 1100	1.7
011 1101	2.0
011 1110	2.4
011 1111	3.0
100 0000	3.4
100 0001	4.0
100 0010	4.8
100 0011	5.9
100 0100	6.8
100 0101	7.9
100 0110	9.5
100 0111	12
100 1000	14
100 1001	16
100 1010	19
100 1011	24
100 1100	27
100 1101	32

Set Value	0 -> 1 Time
100 1110	38 (sec)
100 1111	48
101 0000	54
101 0001	63
101 0010	76
101 0011	95
101 0100	109
101 0101	127
101 0110	152
101 0111	190
101 1000	218
101 1001	254
101 1010	304
101 1011	380
101 1100	436
101 1101	508
101 1110	608
101 1111	760
110 0000	872
110 0001	1016
110 0010	1216
110 0011	1520
110 0100	1744
110 0101	2032
110 0110	2432
110 0111	3040
110 1000	3488
110 1001	4064
110 1010	4864
110 1011	6080
110 1100	(reserved)
:	
111 1110	
111 1111	infinity

4.1.2. -Lin Mode

The variation is shown in linear decrement for normal phase and in linear increment for reverse phase.

-Lin Value	1 → 0 Time
000 0000	0.04 (msec)
000 0001	0.05
000 0010	0.06
000 0011	0.07
000 0100	0.09
000 0101	0.10
000 0110	0.12
000 0111	0.15
000 1000	0.18
000 1001	0.21
000 1010	0.24
000 1011	0.29
000 1100	0.36
000 1101	0.41
000 1110	0.48
000 1111	0.58
001 0000	0.73
001 0001	0.83
001 0010	0.97
001 0011	1.2
001 0100	1.5
001 0101	1.7
001 0110	1.9
001 0111	2.3
001 1000	2.9
001 1001	3.3
001 1010	3.9
001 1011	4.6
001 1100	5.8
001 1101	6.6
001 1110	7.7
001 1111	9.3
010 0000	12
010 0001	13
010 0010	15
010 0011	19
010 0100	23
010 0101	27
010 0110	31

-Lin Value	1 → 0 Time
010 0111	37 (msec)
010 1000	46
010 1001	53
010 1010	62
010 1011	74
010 1100	93
010 1101	0.11 (sec)
010 1110	0.12
010 1111	0.15
011 0000	0.19
011 0001	0.21
011 0010	0.25
011 0011	0.30
011 0100	0.37
011 0101	0.42
011 0110	0.50
011 0111	0.59
011 1000	0.74
011 1001	0.85
011 1010	0.99
011 1011	1.2
011 1100	1.5
011 1101	1.7
011 1110	2.0
011 1111	2.4
100 0000	3.0
100 0001	3.4
100 0010	4.0
100 0011	4.8
100 0100	5.9
100 0101	6.8
100 0110	7.9
100 0111	9.5
100 1000	12
100 1001	14
100 1010	16
100 1011	19
100 1100	24
100 1101	27

-Lin Value	1 → 0 Time
100 1110	32 (sec)
100 1111	38
101 0000	48
101 0001	54
101 0010	63
101 0011	76
101 0100	95
101 0101	109
101 0110	127
101 0111	152
101 1000	190
101 1001	218
101 1010	254
101 1011	304
101 1100	380
101 1101	436
101 1110	508
101 1111	608
110 0000	760
110 0001	872
110 0010	1016
110 0011	1216
110 0100	1520
110 0101	1744
110 0110	2032
110 0111	2432
110 1000	3040
110 1001	3488
110 1010	4064
110 1011	4864
110 1100	(reserved)
:	
111 1110	
111 1111	infinity

4.1.3. +Exp Mode (Normal phase)

Pseudo Inverse-Exponential Increment Mode

+Exp Set Value	1 → 0 Time
000 0000	0.09 (msec)
000 0001	0.11
000 0010	0.13
000 0011	0.16
000 0100	0.18
000 0101	0.21
000 0110	0.25
000 0111	0.32
000 1000	0.36
000 1001	0.42
000 1010	0.51
000 1011	0.64
000 1100	0.73
000 1101	0.85
000 1110	1.0
000 1111	1.3
001 0000	1.5
001 0001	1.7
001 0010	2.0
001 0011	2.5
001 0100	2.9
001 0101	3.4
001 0110	4.1
001 0111	5.1
001 1000	5.8
001 1001	6.8
001 1010	8.1
001 1011	10
001 1100	12
001 1101	14
001 1110	16
001 1111	20
010 0000	23
010 0001	27
010 0010	33
010 0011	41

+Exp Set Value	1 → 0 Time
010 0100	46 (msec)
010 0101	54
010 0110	65
010 0111	81
010 1000	93
010 1001	0.11 (sec)
010 1010	0.13
010 1011	0.16
010 1100	0.19
010 1101	0.22
010 1110	0.26
010 1111	0.33
011 0000	0.37
011 0001	0.43
011 0010	0.52
011 0011	0.65
011 0100	0.74
011 0101	0.87
011 0110	1.0
011 0111	1.3
011 1000	1.5
011 1001	1.7
011 1010	2.1
011 1011	2.6
011 1100	3.0
011 1101	3.5
011 1110	4.2
011 1111	5.2
100 0000	5.9
100 0001	6.9
100 0010	8.3
100 0011	10
100 0100	12
100 0101	14
100 0110	17
100 0111	21

+Exp Set Value	1 → 0 Time
100 1000	24 (sec)
100 1001	28
100 1010	33
100 1011	42
100 1100	48
100 1101	55
100 1110	67
100 1111	83
101 0000	95
101 0001	111
101 0010	133
101 0011	166
101 0100	190
101 0101	222
101 0110	266
101 0111	333
101 1000	380
101 1001	444
101 1010	532
101 1011	666
101 1100	760
101 1101	888
101 1110	1064
101 1111	1332
110 0000	1520
110 0001	1776
110 0010	2128
110 0011	2664
110 1100	(reserved)
:	
111 1110	
111 1111	infinity

4.1.4. +Exp Mode (Reverse phase)

Pseudo Inverse-Exponential Mode with Negative Volume Value

+Exp Set Value	1 -> 0 Time
000 0000	0.08 (msec)
000 0001	0.09
000 0010	0.11
000 0011	0.13
000 0100	0.16
000 0101	0.18
000 0110	0.21
000 0111	0.25
000 1000	0.32
000 1001	0.36
000 1010	0.42
000 1011	0.51
000 1100	0.64
000 1101	0.73
000 1110	0.85
000 1111	1.0
001 0000	1.3
001 0001	1.5
001 0010	1.7
001 0011	2.0
001 0100	2.5
001 0101	2.9
001 0110	3.4
001 0111	4.1
001 1000	5.1
001 1001	5.8
001 1010	6.8
001 1011	8.1
001 1100	10
001 1101	12
001 1110	14
001 1111	16
010 0000	20
010 0001	23
010 0010	27
010 0011	33

+Exp Set Value	1 -> 0 Time
010 0100	41 (msec)
010 0101	46
010 0110	54
010 0111	64
010 1000	81
010 1001	93
010 1010	0.11 (sec)
010 1011	0.13
010 1100	0.16
010 1101	0.19
010 1110	0.22
010 1111	0.26
011 0000	0.33
011 0001	0.37
011 0010	0.43
011 0011	0.52
011 0100	0.65
011 0101	0.74
011 0110	0.87
011 0111	1.0
011 1000	1.3
011 1001	1.5
011 1010	1.7
011 1011	2.1
011 1100	2.6
011 1101	3.0
011 1110	3.5
011 1111	4.2
100 0000	5.2
100 0001	5.9
100 0010	6.9
100 0011	8.3
100 0100	10
100 0101	12
100 0110	14
100 0111	17

+Exp Set Value	1 -> 0 Time
100 1000	21 (sec)
100 1001	24
100 1010	28
100 1011	33
100 1100	42
100 1101	48
100 1110	55
100 1111	67
101 0000	83
101 0001	95
101 0010	111
101 0011	133
101 0100	166
101 0101	190
101 0110	222
101 0111	266
101 1000	333
101 1001	380
101 1010	444
101 1011	532
101 1100	666
101 1101	760
101 1110	888
101 1111	1064
110 0000	1332
110 0001	1520
110 0010	1776
110 0011	2128
110 1100	(reserved)
:	
111 1110	
111 1111	infinity

4.1.5. –Exp Mode

Exponential Decrement Mode

-Exp Set Value	1 → 0.1 Time
000 0000	0.07 (msec)
000 0001	0.09
000 0010	0.11
000 0011	0.14
000 0100	0.18
000 0101	0.21
000 0110	0.25
000 0111	0.31
000 1000	0.39
000 1001	0.45
000 1010	0.53
000 1011	0.64
000 1100	0.81
000 1101	0.93
000 1110	1.1
000 1111	1.3
001 0000	1.6
001 0001	1.9
001 0010	2.2
001 0011	2.6
001 0100	3.3
001 0101	3.8
001 0110	4.4
001 0111	5.3
001 1000	6.7
001 1001	7.6
001 1010	8.9
001 1011	11
001 1100	13
001 1101	15
001 1110	18
001 1111	21
010 0000	27
010 0001	31
010 0010	36
010 0011	43
010 0100	53
010 0101	61
010 0110	71

-Exp Set Value	1 → 0.1 Time
010 0111	86 (msec)
010 1000	0.11 (sec)
010 1001	0.12
010 1010	0.14
010 1011	0.17
010 1100	0.21
010 1101	0.24
010 1110	0.29
010 1111	0.34
011 0000	0.43
011 0001	0.49
011 0010	0.57
011 0011	0.68
011 0100	0.86
011 0101	0.98
011 0110	1.1
011 0111	1.4
011 1000	1.7
011 1001	2.0
011 1010	2.3
011 1011	2.7
011 1100	3.4
011 1101	3.9
011 1110	4.6
011 1111	5.5
100 0000	6.8
100 0001	7.8
100 0010	9.1
100 0011	11
100 0100	14
100 0101	16
100 0110	18
100 0111	22
100 1000	27
100 1001	31
100 1010	36
100 1011	44
100 1100	55
100 1101	63

-Exp Set Value	1 → 0.1 Time
100 1110	73 (sec)
100 1111	88
101 0000	109
101 0001	125
101 0010	146
101 0011	175
101 0100	219
101 0101	250
101 0110	292
101 0111	350
101 1000	438
101 1001	500
101 1010	584
101 1011	700
101 1100	876
101 1101	1000
101 1110	1168
101 1111	1400
110 0000	1752
110 0001	2000
110 0010	2336
110 0011	2800
110 0100	3504
110 0101	4000
110 0110	4672
110 0111	5600
110 1000	7008
110 1001	8000
110 1010	9344
110 1011	11200
110 1100	(reserved)
:	
111 1110	
111 1111	infinity

4.1.6. Decay Rate (DR)

Exponential Decrement Mode

-Exp Set Value	1 → 0.1 Time
0000	0.07 (msec)
0001	0.18
0010	0.39
0011	0.81
0100	1.6
0101	3.3
0110	6.7
0111	13
1000	27
1001	53
1010	0.11 (sec)
1011	0.21
1100	0.43
1101	0.86
1110	1.7
1111	3.4

4.1.7. Sustain Level (SL)

Set Value	Envelope Level
0000	1/16
0001	2/16
0010	3/16
0011	4/16
0100	5/16
0101	6/16
0110	7/16
0111	8/16
1000	9/16
1001	10/16
1010	11/16
1011	12/16
1100	13/16
1101	14/16
1110	15/16
1111	1

Note: when the set value is 1111, the Decay section immediately before is processed only for 1 Ts.

4.1.8. –Lin Mode for Release Rate (RR)

Linear Decrement Mode

-Lin Set Value	1 → 0 Time
0 0000	0.04 (msec)
0 0001	0.09
0 0010	0.18
0 0011	0.36
0 0100	0.73
0 0101	1.5
0 0110	2.9
0 0111	5.8
0 1000	12
0 1001	23
0 1010	46
0 1011	93
0 1100	0.19 (sec)
0 1101	0.37
0 1110	0.74
0 1111	1.5
1 0000	3.0
1 0001	5.9
1 0010	12
1 0011	24
1 0100	48
1 0101	95
1 0110	190
1 0111	380
1 1000	760
1 1001	1520
1 1010	3040
1 1011	(reserved)
:	
1 1110	
1 1111	infinity

4.1.9. –Exp Mode for Release Rate (RR)

Exponential Decrement Mode

-Exp Set Value	1 → 0.1 Time
0 0000	0.07 (msec)
0 0001	0.18
0 0010	0.39
0 0011	0.81
0 0100	1.6
0 0101	3.3
0 0110	6.7
0 0111	13
0 1000	27
0 1001	53
0 1010	0.11 (sec)
0 1011	0.21
0 1100	0.43
0 1101	0.86
0 1110	1.7
0 1111	3.4
1 0000	6.8
1 0001	14
1 0010	27
1 0011	55
1 0100	109
1 0101	219
1 0110	438
1 0111	876
1 1000	1752
1 1001	3504
1 1010	7008
1 1011	(reserved)
:	
1 1110	
1 1111	infinity

(This page is left blank intentionally)