

Monsoon Universal Twin Pumps

Monsoon Universal pumps remove the guesswork from pump selection. Fully automatic, they will function under both positive and negative head conditions and are suitable for installation into an open vented hot and cold water system. Universal Monsoon pumps do not require a gravity flow of water to start.

Universal twin pumps are designed for installation into both the hot and cold water supplies - boosting both equally.

They can be used to:

- Boost hot and cold water services to the complete home, bathroom, kitchen or cloakroom.
- Pressurise the supply in applications such as loft conversions, where outlets are higher than the water source.
- Pressurise the complete system where it is uncertain whether a positive flow naturally exists.
- All pumps supplied with 22 mm push-in x 300 mm anti-vibration flexible hoses.
- All flexible hoses feature integral isolating valves
- All pumps supplied pre-wired with 1.5 metre cable, anti-vibration feet.
- All pumps have G $\frac{3}{4}$ threaded connections.
- Reassurance of up to a 5-year guarantee (subject to conditions)



Monsoon Universal Twin Pumps

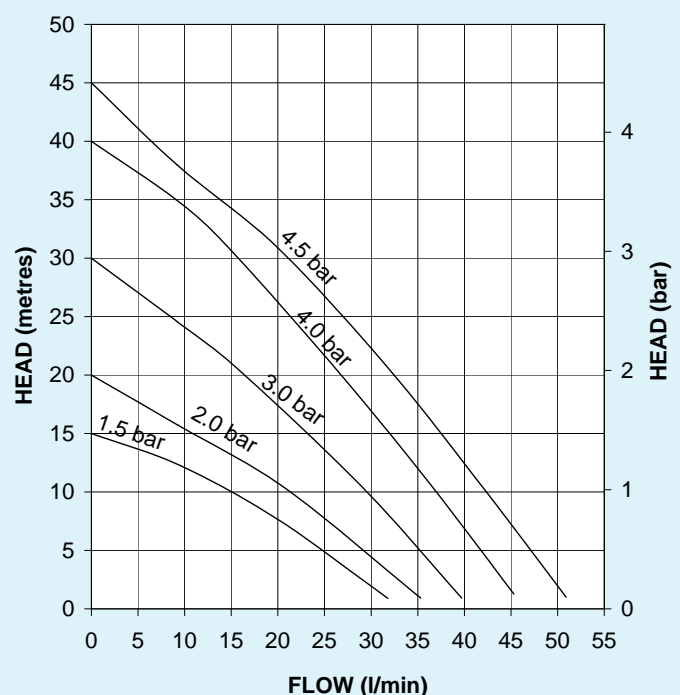

5

year guarantee!

subject to conditions

Monsoon Universal Twin Pumps

System Booster Pumps		1.5 bar Twin 46480	2.0 bar Twin 46480	3.0 bar Twin 46410	4.0 bar Twin 46411	4.5 bar Twin 46412
Performance (bar) @ 9 l/min (one shower)		1.3	1.5	2.5	3.5	3.8
Performance (bar) @ 18 l/min (two showers)		0.8	1.1	1.9	2.8	3.2
Maximum Flow Litres Per Minute		32	35	40	45	51
Maximum Head Valve Closed (bar)		1.5	2.0	3.0	4.0	4.5
Maximum Inlet Static Head (Metres)		8	8	8	12	12
Hoses	G 3/4" Female x 22 mm Push-in c/w isolating valves x 305 mm long	✓	✓	✓	✓	✓
G 3/4" Male Pump Connections		✓	✓	✓	✓	✓
Inlet Strainer		✓	✓	✓	✓	✓
Stuart Hard Faced Mechanical Seal		✓	✓	✓	✓	✓
WRAS Approved 65°C max		✓	✓	✓	✓	✓
Flow Switch Sensitivity approx. 0.6 l/min		✓	✓	✓	✓	✓
Pressure Switch		✓	✓	✓	✓	✓
PCB	Run On Timer 3 Sec	✓	✓	✓	✓	✓
	Dry Run Protection	✓				
Power Supply 230/1/50		✓	✓	✓	✓	✓
Enclosure Rating BS EN 60529		IPX4	IPX4	IPX4	IPX4	IPX4
Motor Type, Induction, Permanent Capacitor, Auto Resetting Protective Thermotrip		✓	✓	✓	✓	✓
Power Consumption (Watts)		355	435	655	875	1135
Full Load Amps		1.5	1.9	2.9	3.9	5.1
Fuse Rating Amps		5	5	5	13	13
Pre-Wired		✓	✓	✓	✓	✓
Duty Rating Continuous (S1) @ 9 l/min and above		✓	✓	✓	✓	✓
Length mm		265	265	265	300	310
Width mm		162	162	162	162	162
Height mm without flexibles		243	243	243	243	243
Gross Weight Packed (kg)		9.2	9.2	10.4	12.5	13.3

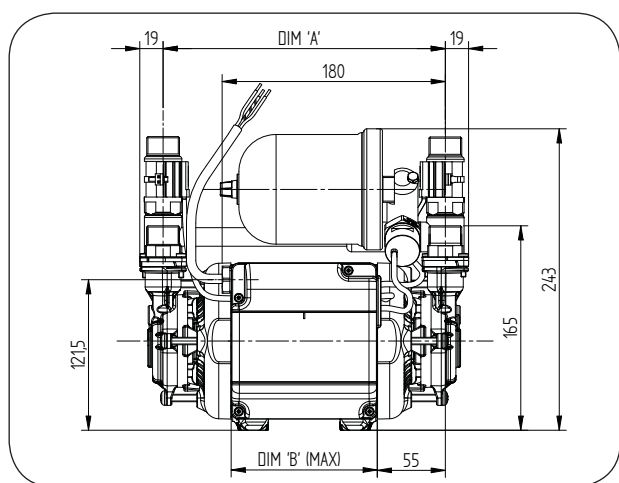

Pump Description	Dim. 'A'	Dim. 'B'
1.5 bar Twin	227 mm	119 mm
2.0 bar Twin	227 mm	119 mm
3.0 bar Twin	227 mm	119 mm
4.0 bar Twin	262 mm	154 mm
4.5 bar Twin	272 mm	164 mm



Stuart Turner Ltd
Henley-on-Thames
Oxfordshire RG9 2AD
England
Telephone: +44 (0)1491 572655
Fax: +44 (0)1491 573704

Email:
pumps@stuart-turner.co.uk
Web:
www.stuart-turner.co.uk

V.A.T. REG. No. 199 0987 92.
Registered in England No. 88368.
Registered Office:
Market Place, Henley-on-Thames