

FEATURES

- Automatic flush function
- Automatic open/close lid
- New reinforced base plate for enhanced durability
- Gentle Aerated, Warm Water, Dual Action Spray with cycling movement and massage feature
- Adjustable water temperature and volume
- Warm air drying with three variable temperature settings
- Automatic air deodorizer
- Convenient wireless Remote Control with large LCD panel
- SoftClose® anti-bacterial seat
- Convenient Control Panel
- Heated Seat with Temperature Control
- Docking Station Easy to Install and Clean

MODELS

- SW564T695
Elongated front auto-flush trip lever for G-Max® toilets
- SW564T694
Elongated front auto-flush trip lever for Ultimate® toilets
- SW563T695
Round front auto-flush trip lever for G-Max® toilets
- SW563T694
Round front auto-flush trip lever for Ultimate® toilets
- THU9329#01
Traditional style lid (sold separately)
Compatible with SW564T695#01 and SW564T694#01

COLORS/FINISHES

- Standard
#01 Cotton
#11 Colonial White
#12 Sedona Beige

CODES/STANDARDS

- Meets and exceeds ASME A112.4.2, ASME A112.18.1/CSA B125.1, UL 1431, CSA C22.2 #68
- Certifications: IAPMO(cUPC), Intertek, State of Massachusetts, City of Los Angeles and others
- Code Compliance: UPC, IPC, NSPC, NPC Canada, and others

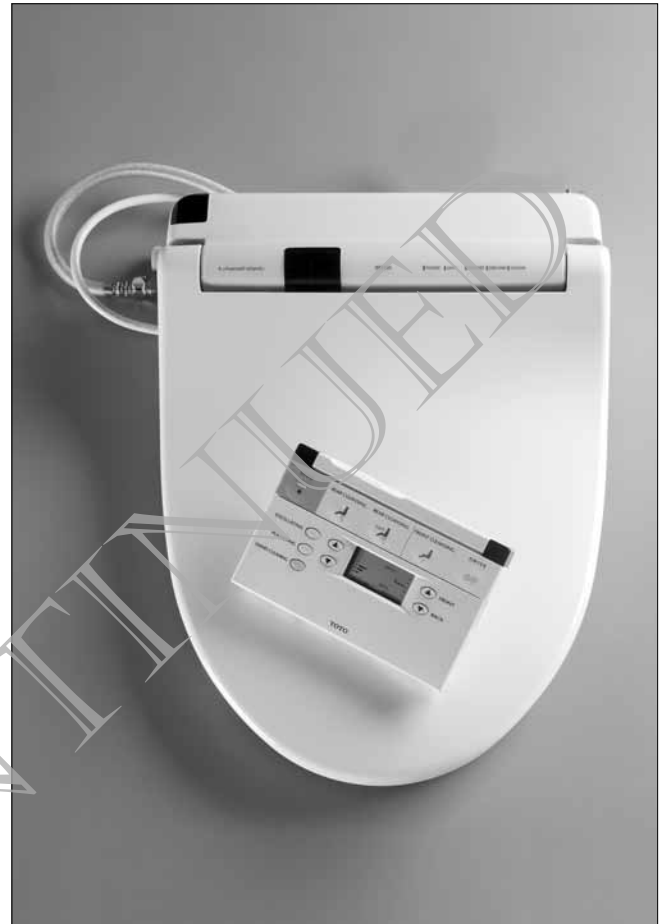

PRODUCT SPECIFICATION

Seat shall be model # SW564 or # SW563_____. Seat shall have automatic flush function. Seat shall have automatic open/close lid. Seat shall have gentle aerated, warm water, dual action spray with cycling movement and massage feature. Seat shall have adjustable water temperature and volume. Seat shall have warm air drying with three variable temperature settings. Seat shall have automatic air deodorizer. Seat shall include wireless remote control with large LCD panel. Seat shall be solid anti-bacterial plastic with closed front seat and cover. Seat shall include power cord, and water supply hoses.

SPECIFICATIONS

- Power Rating: 120V AC, 60Hz, 1277W
- Power Cord: Maximum length: 3.3 ft/100 cm, 3 prong grounded plug
- Water Feature: Adjustable Water Flow Rate:
Front washing - from 9 - 14.5 oz/min.
Rear washing - from 9 - 14.5 oz/min.
- Washing Spray Temp: Minimum: 86°F/30°C
Maximum: 104°F/40°C
- Water Heater Capacity: 1200W
- Water Heater Tank Volume: 0.30 gal./1.14L
- Safety Device: Thermal fuse, bimetal switch (overheating, auto reset), float switch (no water)
- Back Flow Prevention: Vacuum breaker, One-way Valve
- Drying Feature: Air temperature:
High: about 140°F/60°C
Medium: about 122°F/50°C
Low: about 104°F/40°C
- Dryer Air Capacity: 10.5ft³/min
- Dryer Heater Capacity: 350W
- Seat Warming Feature: Surface Temperature:
Minimum: 81°F/27°C
Maximum: 97°F/36°C
- Seat Heater Capacity: 50W
- Safety Device: Thermal fuse
- Water Supply Pressure: Minimum: 20 psi
Maximum: 80 psi
- Ambient Temperature: Range:
33°F/1°C to 104°F/40°C
- Weight: Net: 11.5 lbs/5.2 kg
Gross: (w/pkg) 17.4lbs/7.9kg
- Product Dimensions: 15-3/4" W x 21" D x 5-1/8" H (elongated)
15-3/4" W x 19-7/8" D x 5-1/8" H (round)
- Warranty: One Year Limited Warranty

INSTALLATION NOTES

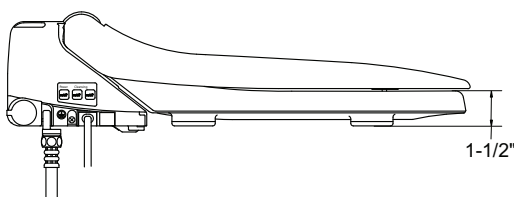
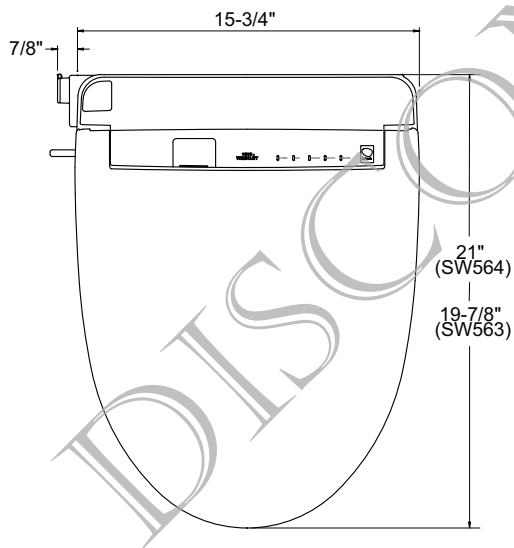

- Prior to order and installation of Washlet® S400: Please contact your TOTO USA, INC. Wholesaler / Distributor or TOTO USA, INC. Technical Support (1-888-295-8134) to request item number THU9180 (Washlet® S400 Flush Mechanism Tester) THU9180 is a small device that is used to confirm that the Auto Flush Lever will clear the Fill Valve on the toilets that were purchased without the TOTO USA, INC. Pre-Installed Auto Flush Mechanism.
- Washlet® S400 will not fit certain toilets. Consult your dealer or a Toto® representative.
- Electrical service requirements -120VAC, 15A, 60Hz protected by Class A GFCI.