



**CE EMC
TEST REPORT**

For

Model : F208B

Data Applies To : F208C ; F108X ; F108Y ; LCS-FS6108-C

Issued for

NETRONIX, INC.

No. 945, Boai St., Jubei City, Hsinchu, Taiwan, 30265, R. O. C.

Issued by

**Compliance Certification Services Inc.
Hsinchu Lab.**

**NO. 989-1 Wen Shan Rd., Shang Shan Village,
Qionglin Shiang Hsinchu County 30741, Taiwan, R.O.C**

TEL: +886-3-5921698

FAX: +886-3-5921108

<http://www.ccsrf.com>

E-Mail : service@ccsrf.com

Issued Date: January 09, 2014



Note: This report shall not be reproduced except in full, without the written approval of Compliance Certification Services Inc. This document may be altered or revised by Compliance Certification Services Inc. personnel only, and shall be noted in the revision section of the document. The client should not use it to claim product endorsement by TAF or any government agencies. The test results of this report relate only to the tested sample identified in this report.



Revision History

Rev.	Issue Date	Revisions	Effect Page	Revised By
00	01/09/2014	Initial Issue	All Page 62	Gloria Chang



TABLE OF CONTENTS

TITLE	PAGE NO.
1. TEST REPORT CERTIFICATION	4
2. EUT DESCRIPTION	5
3. DESCRIPTION OF TEST MODES	6
4. TEST METHODOLOGY	7
5. FACILITIES AND ACCREDITATION	7
5.1 FACILITIES	7
5.2 ACCREDITATIONS.....	7
5.3 MEASUREMENT UNCERTAINTY	8
6. SETUP OF EQUIPMENT UNDER TEST.....	9
7. EMISSION TEST	10
7.1 RADIATED EMISSION.....	10-14
7.2 CONDUCTED EMISSION.....	15-22
7.3 HARMONIC CURRENT EMISSION.....	23-27
7.4 VOLTAGE FLUCTUATION AND FLICKER.....	28-29
8. IMMUNITY TEST	30
8.1 ELECTROSTATIC DISCHARGE (ESD).....	31-36
8.2 RF ELECTROMAGNETIC FIELD (RS)	37-39
8.3 FAST TRANSIENTS COMMON MODE (EFT).....	40-42
8.4 SURGE	43-45
8.5 CONDUCTED RADIO FREQUENCY DISTURBANCES (CS)	46-47
8.6 POWER FREQUENCY MAGNETIC FIELDS (PFMF).....	48-49
8.7 VOLTAGE DIPS & VOLTAGE INTERRUPTIONS (DIP)	50-51
APPENDIX SETUP PHOTOS	52-62



1. TEST REPORT CERTIFICATION

Applicant : NETRONIX, INC.
Address : No. 945, Boai St., Jubei City, Hsinchu, Taiwan, 30265,
R. O. C.
Model : F208B
Data Applies To : F208C ; F108X ; F108Y ; LCS-FS6108-C
Tested Date : January 03 ~ 09, 2014

APPLICABLE STANDARD		
Emission Standard	Item	Test Result
EN 55022:2010, CLASS B	Radiated Emission	PASS
	Conducted Emission	PASS
EN 61000-3-2:2006 + A2:2009	Harmonic Current Emissions	PASS
EN 61000-3-3:2008	Voltage Fluctuation & Flicker	PASS
Immunity Standard EN 55024:2010	Item	Test Result
IEC 61000-4-2:2008	Electrostatic Discharge	PASS
IEC 61000-4-3:2006 + A1:2007 + A2:2010	RF Electromagnetic Field	PASS
IEC 61000-4-4:2012	Fast Transients Common Mode	PASS
IEC 61000-4-5:2005	Surge	PASS
IEC 61000-4-6:2008	Conducted Radio Frequency Disturbances	PASS
IEC 61000-4-8:2009	Power Frequency Magnetic Fields	PASS
IEC 61000-4-11:2004	Voltage Dips & Voltage Interruptions	PASS

WE HEREBY CERTIFY THAT: The above equipment has been tested by Compliance Certification Services Inc., and found compliance with the requirements set forth in the technical standards mentioned above. The results of testing in this report apply only to the product/system, which was tested. Other similar equipment will not necessarily produce the same results due to production tolerance and measurement uncertainties.

Approved by:

Sb. Lu
Sr. Engineer

Reviewed by:

Gundam Lin
Sr. Engineer



2. EUT DESCRIPTION

Model Number	F208B
Data Applies To	F208C ; F108X ; F108Y ; LCS-FS6108-C
Identify Number	T140103S01-A
Received Date	January 03, 2014
Power Rating	5Vdc
Test Voltage	230Vac/50Hz
DC Power Cable Type	Non-Shielded cable 1m (Non-detachable)
I/O Port	RJ-45 Port × 8, DC Input Port × 1

Power Adapter :

No.	Manufacturer	Model No.	Power Input	Power Output
1	LEI	MU03B5050060-C5	100-240Vac, 50/60Hz, 0.15A	5.0V, 0.6A

The difference of the series model

Mode Number	Trade Name	Difference	
		Housing	Loop + Qos software
F208B	NETRONIX	Metal	Without
F208C		Metal	With
F108X		Plastic	Without
F108Y		Plastic	With
LCS-FS6108-C	LONGSHINE	Plastic	With

Remark : 1. For more details, please refer to the User's manual of the EUT.
2. The model F208B ; F108X was considered the main model for testing.



3. DESCRIPTION OF TEST MODES

1. The following test modes were scanned during the preliminary test:

No.	Pre-Test Mode
1	Normal Operating / F208B
2	Normal Operating / F108X

2. After the preliminary scan, the following test mode was found to produce the highest emission level.

Final Test Mode		
Emission	Radiated Emission	Normal Operating / F208B
	Conducted Emission	
	Harmonic & Flicker	
Immunity	Electrostatic Discharge	Normal Operating / F208B
	RF Electromagnetic Field	Normal Operating / F108X
	Power Frequency Magnetic Fields	Normal Operating / F208B
	Fast Transients Common Mode	
	Surge	
	Conducted Radio Frequency Disturbances	
	Voltage Dips & Voltage Interruptions	

Remark : Then, the above highest emission mode of the configuration of the EUT and cable was chosen for all final test items.



4. TEST METHODOLOGY

The tests documented in this report were performed in accordance with the following standards: EN 55022:2010, EN 61000-3-2:2006 + A2:2009, EN 61000-3-3:2008, EN 55024:2010.

5. FACILITIES AND ACCREDITATION

5.1 FACILITIES

All measurement facilities used to collect the measurement data are located at
NO. 989-1 Wen Shan Rd., Shang Shan Village,
Qionglin Shiang Hsinchu County 30741, Taiwan, R.O.C

The sites are constructed in conformance with the requirements of ANSI C63.4:2009 and CISPR 22. All receiving equipment conforms to CISPR 16-1-1, CISPR 16-1-2, CISPR 16-1-3, CISPR 16-1-4, CISPR 16-1-5.

5.2 ACCREDITATIONS

Our laboratories are accredited and approved by the following approval agencies according to ISO/IEC 17025.

Taiwan	TAF
---------------	-----

The measuring facility of laboratories has been authorized or registered by the following approval agencies.

Canada	INDUSTRY CANADA
Japan	VCCI
Taiwan	BSMI
USA	FCC MRA

Copies of granted accreditation certificates are available for downloading from our web site, <http://www.ccsrf.com>



5.3 MEASUREMENT UNCERTAINTY

The following table is for the measurement uncertainty, which is calculated as per the document CISPR 16-4-2.

PARAMETER	UNCERTAINTY
Open Area Test Site (OATS No.3) / Radiated Emission, 30 to 1000 MHz	+/- 4.21
Semi Anechoic Chamber (966 Chamber_B) / Radiated Emission, 30 to 1000 MHz	+/- 3.97
Semi Anechoic Chamber (966 Chamber_B) / Radiated Emission, 1 to 18GHz	+/- 3.58
Semi Anechoic Chamber (966 Chamber_B) / Radiated Emission, 18 to 26 GHz	+/- 3.59
Semi Anechoic Chamber (966 Chamber_B) / Radiated Emission, 26 to 40 GHz	+/- 3.81
Conducted Emission (Mains Terminals), 9kHz to 30MHz	+/- 2.48
Conducted Emission (Telecommunication Port), 150kHz to 30MHz	+/- 3.09

This uncertainty represents an expanded uncertainty expressed at approximately the 95% confidence level using a coverage factor of k=2.

Consistent with industry standard (e.g. CISPR 22, clause 11, Measurement Uncertainty) determining compliance with the limits shall be base on the results of the compliance measurement. Consequently the measure emissions being less than the maximum allowed emission result in this be a compliant test or passing test.

The acceptable measurement uncertainty value without requiring revision of the compliance statement is base on conducted and radiated emissions being less than U_{CISPR} which is 3.6dB and 5.2dB respectively. CCS values (called U_{Lab} in CISPR 16-4-2) is less than U_{CISPR} as shown in the table above. Therefore, MU need not be considered for compliance.



6. SETUP OF EQUIPMENT UNDER TEST

SUPPORT EQUIPMENT

No.	Product	Manufacturer	Model No.	Serial No.	FCC ID
1	Notebook PC	DELL	INSPIRON 640m PP19L	CN-0MG532-70166-71 G-03EC	DoC
2	Notebook PC	DELL	Latitude D610 PP01L	CN-0XD762-48643-637 -1743	DoC
3	Switch Hub	ASUS	GX1008B	90-Q872AN1N0NAMA0 -88QSA1003522	---

No.	Signal Cable Description
1	Non-shielded RJ-45 cable, 1.5m × 6
2	Non-shielded RJ-45 cable, 10m × 2

SETUP DIAGRAM FOR TESTS

EUT & peripherals setup diagram is shown in appendix setup photos.

EUT OPERATING CONDITION

All the equipment/cables were placed in the worst-case configuration to maximize the emission during the test. Grounding was established in accordance with the manufacturer's requirements and conditions for the intended use.

1. EUT & peripherals setup diagram is shown in appendix setup photos.
2. Notebook PC 1 & PC 2 link to EUT.
3. Notebook PC 1 ping to Notebook PC 2.
4. EUT port 2~6 link to load.
5. All of the functions are under run.
6. Start test.



7. EMISSION TEST

7.1 RADIATED EMISSION

LIMITS

(1) Frequency Range below 1GHz

Frequency range (MHz)	Field Strength Quasi-peak limits (dB μ V/m)		Distance (meters)
	Class A	Class B	
30 - 230	40	30	10
230 - 1000	47	37	10

Remark: (1) The lower limit shall apply at the transition frequency.

(2) Additional provisions may be required for cases where interference occurs.

(2) Frequency Range above 1GHz

Frequency range (GHz)	Field Strength Limit (dB μ V/m)				Distance (meters)
	Class A		Class B		
	Peak	Average	Peak	Average	
1 - 3	76	56	70	50	3
3 - 6	80	60	74	54	3

Remark: The lower limit shall apply at the transition frequency.

According to EN55022: 2010 clause 6.2, the measurement frequency range shown in the following table:

Highest frequency generated or used within the EUT or on which the EUT operates or tunes (MHz)	Upper frequency of measurement range (MHz)
Less than 108	1000
108-500	2000
500-1000	5000
Above 1000	5 times of the highest frequency or 6GHz, whichever is less



TEST EQUIPMENT

Radiated Emission below 1GHz / OATS3

Name of Equipment	Manufacturer	Model	Serial Number	Calibration Due
Bi-log Antenna	SCHAFFER	CBL6112B	2696	09/11/2014
EMI Test Receiver	ROHDE & SCHWARZ	ESCI	101131	01/14/2014
Pre-Amplifier	EMCI	EMC330H	980140	05/14/2014

Remark: Each piece of equipment is scheduled for calibration once a year.

Radiated Emission above 1GHz / 966Chamber_B

Name of Equipment	Manufacture	Model	Serial Number	Calibration Due
Spectrum Analyzer	Agilent	E4446A	MY46180323	04/15/2014
EMI Test Receiver	ROHDE & SCHWARZ	ESCI	101131	01/14/2014
Bi-log Antenna	SCHWARZBECK	VULB 9168	9168-250	09/12/2014
Broad-Band Horn Antenna	SCHWARZBECK	BBHA 9120 D	9120D-778	09/12/2014
Pre-Amplifier	Agilent	8447D	2944A10052	07/16/2014
Pre-Amplifier	Agilent	8449B	3008A01916	07/16/2014
Notch Filters Band Reject	Micro-Tronics	BRM05702-01	026	N.C.R

*Remark: 1. Each piece of equipment is scheduled for calibration once a year.
2. N.C.R = No Calibration Request.*



TEST SETUP

The diagram below shows the test setup that is utilized to make the measurements for emission below 1GHz.

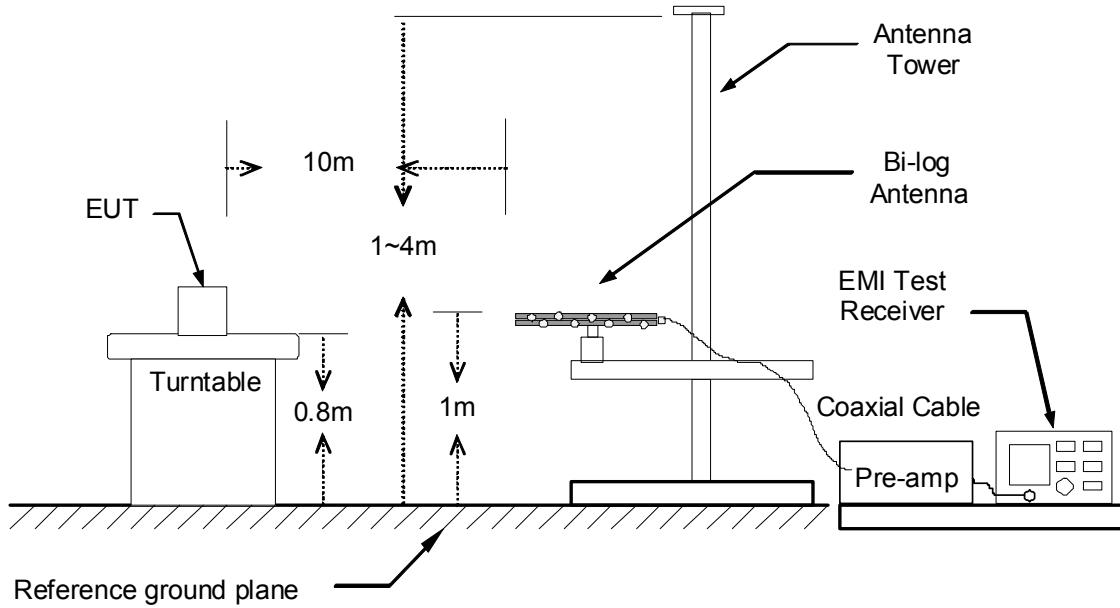

The diagram below shows the test setup that is utilized to make the measurements for emission above 1GHz.

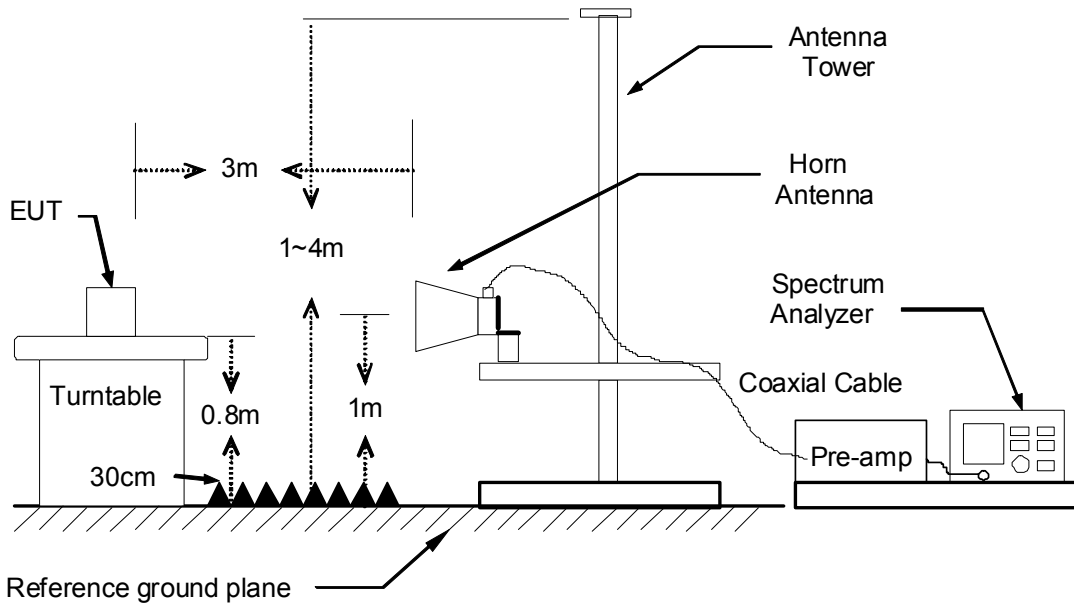



TEST PROCEDURE

The basic test procedure was in accordance with EN 55022.

The devices under test were placed on a rotatable table top 0.8 meter above ground. The table was rotated 360 degrees to determine the position of the highest radiation. EUT is set 3 or 10m meters from the interference receiving antenna which is mounted on the top of a variable height mast. The antenna height is varied between one meter and four meters above ground to find the maximum value of the field strength both horizontal polarization and vertical polarization of the antenna are set to make the measurement.

Note :

1. The bandwidth setting on the E.M.I. meter (EMI TEST RECEIVER) is 120 KHz. The levels are Quasi-Peak value readings. The frequency spectrum from 30MHz to 1000MHz was investigated.
2. The resolution bandwidth, video bandwidth and detector of test spectrum analyzer is 1 MHz, 1MHz and Peak for Peak detection and frequency above 1GHz.
3. The resolution bandwidth, video bandwidth and detector of test spectrum analyzer is 1 MHz, 1MHz and Average for Average detection and frequency above 1GHz.



TEST RESULTS

Above 1GHz

No applicable, when the highest frequency of the internal sources of the EUT is less than 108MHz, the measurement shall only be made up to 1 GHz.

Below 1 GHz

Test Model	F208B	Test By	Alan Wu
Test Mode	Normal Operating	Test Date	2014/01/06
		Temp. & Humidity	22°C, 52%

OATS3 at 10Meter / Horizontal								
Frequency (MHz)	Corr. Factor (dB/m)	Meter Reading (dBµV)	Limits (dBµV/m)	Emission Level (dBµV/m)	Margin Limit (dB)	Azimuth (°)	Height (cm)	Remark
250.00	-16.43	42.40	37.00	25.97	-11.03	120	400	QP
401.00	-12.24	34.50	37.00	22.26	-14.74	116	100	QP
500.00	-10.09	32.50	37.00	22.41	-14.59	0	100	QP
625.00	-7.87	29.30	37.00	21.43	-15.57	220	100	QP
750.00	-5.15	30.40	37.00	25.25	-11.75	300	100	QP
875.00	-3.71	26.50	37.00	22.80	-14.21	80	100	QP

OATS3 at 10Meter / Vertical								
Frequency (MHz)	Corr. Factor (dB/m)	Meter Reading (dBµV)	Limits (dBµV/m)	Emission Level (dBµV/m)	Margin Limit (dB)	Azimuth (°)	Height (cm)	Remark
71.40	-23.91	38.30	30.00	14.39	-15.61	90	100	QP
125.00	-17.98	36.20	30.00	18.22	-11.78	160	100	QP
250.00	-16.43	45.60	37.00	29.17	-7.83	220	100	QP
750.00	-5.15	30.80	37.00	25.65	-11.35	180	100	QP
875.00	-3.71	30.20	37.00	26.50	-10.51	0	100	QP
945.00	-3.33	29.30	37.00	25.98	-11.03	210	100	QP

Remark:

1. Quasi-peak test would be performed if the peak result were greater than the quasi-peak limit.
2. Data of measurement within this frequency range shown " --- " in the table above means the reading of emissions are attenuated more than 20dB below the permissible limits or the field strength is too small to be measured.
3. Correction Factor (dB/m) = Antenna Factor (dB/m) + Cable Loss (dB) – PreAmp.Gain (dB)
4. Emission Level (dBµV/m) = Correction Factor (dB/m) + Meter Reading (dBµV)
5. Margin (dB) = Emission Level (dBµV/m) - Quasi-peak limit (dBµV/m)



7.2 CONDUCTED EMISSION

LIMITS

(1) Mains Ports

Frequency Range (MHz)	Voltage Limits (dBµV)			
	Class A		Class B	
	Quasi-peak	Average	Quasi-peak	Average
0.15 - 0.50	79	66	66 - 56	56 - 46
0.50 - 5.00	73	60	56	46
5.00 - 30.0	73	60	60	50

Remark: (1) The limit decreases linearly with logarithm of the frequency in the range 0.15 MHz to 0.50 MHz.
 (2) The lower limit shall apply at the transition frequency.

(2) Telecommunication Ports

Frequency Range (MHz)	Voltage Limits (dBµV)				Current Limits (dBµA)			
	Class A		Class B		Class A		Class B	
	Quasi-peak	Average	Quasi-peak	Average	Quasi-peak	Average	Quasi-peak	Average
0.15 - 0.50	97 - 87	84 - 74	84 - 74	74 - 64	53 - 43	40 - 30	40 - 30	30 - 20
0.50 - 30.0	87	74	74	64	43	30	30	20

Remark: (1) The limit decreases linearly with logarithm of the frequency in the range 0.15 MHz to 0.50 MHz.
 (2) The current and voltage disturbance limits are derived for use with an impedance stabilization network (ISN) which presents a common mode (asymmetric mode) impedance of 150Ω to the telecommunication port under test (conversion factor is $20 \log_{10} 150 / 1 = 44$ dB).

TEST EQUIPMENT

Name of Equipment	Manufacturer	Model	Serial Number	Calibration Due
L.I.S.N	SCHWARZBECK	NSLK 8127	8127-465	08/11/2014
L.I.S.N	SCHWARZBECK	NSLK 8127	8127-473	03/07/2014
EMI Receiver	ROHDE & SCHWARZ	ESCS 30	835418/008	10/16/2014
Pulse Limiter	ROHDE & SCHWARZ	ESH3-Z2	100117	07/01/2014
I.S.N.	TESEQ	T8	24313	03/31/2014
Current Probe	SCHAFFNER	SMZ11	14802	07/01/2014
Ferrite Clamp	SCHAFFNER	KEMA801	15937	N.C.R

Remark: 1. Each piece of equipment is scheduled for calibration once a year.
 2. N.C.R = No Calibration Request.



TEST SETUP

(1) Mains Ports

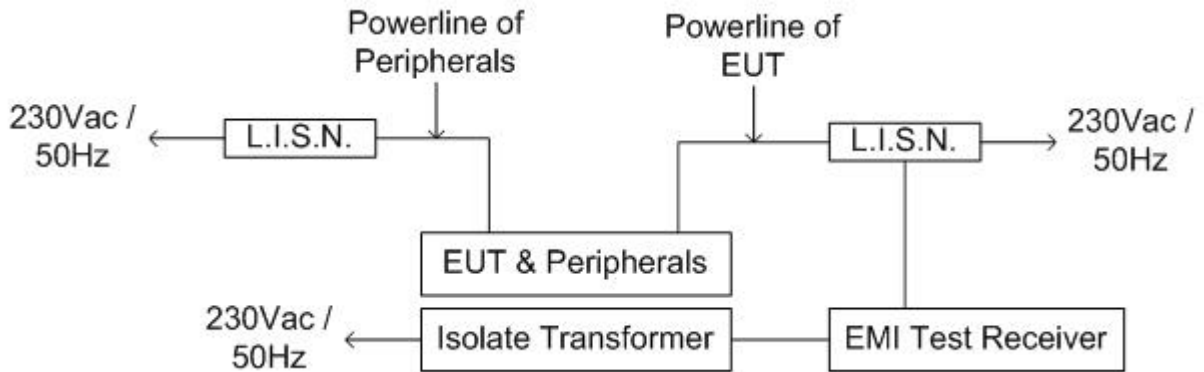
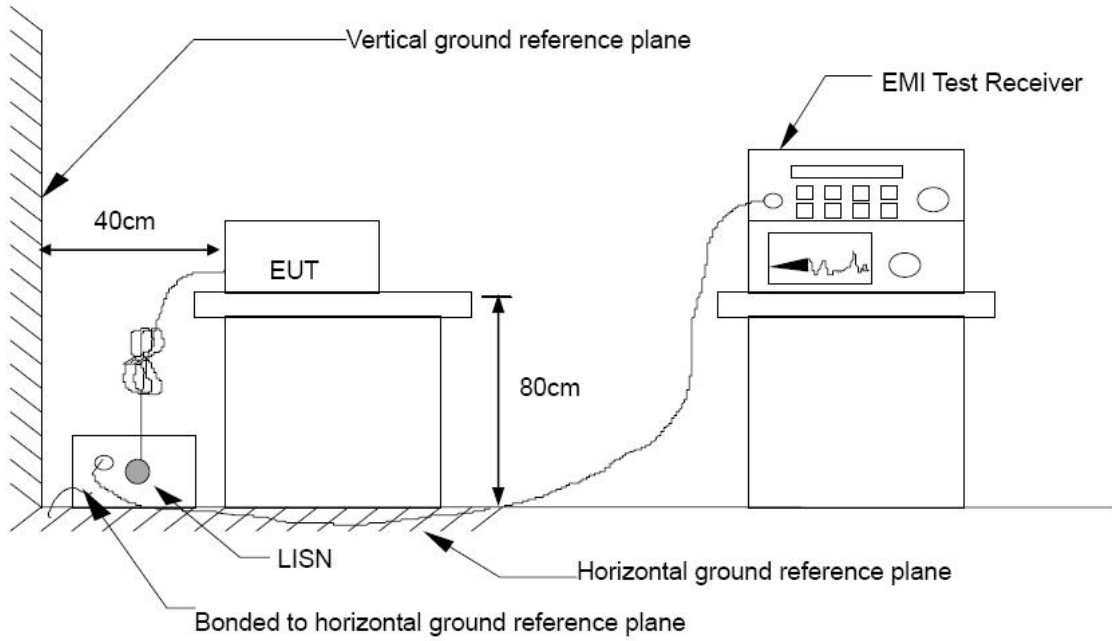

(2) Telecommunication Ports

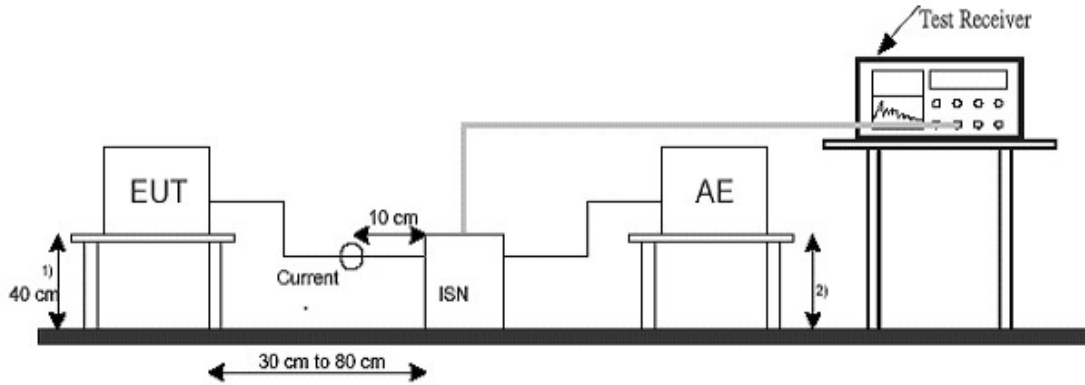

- 1) Distance to the ground reference plane (vertical or horizontal).
- 2) Distance to the ground reference plane is not critical.

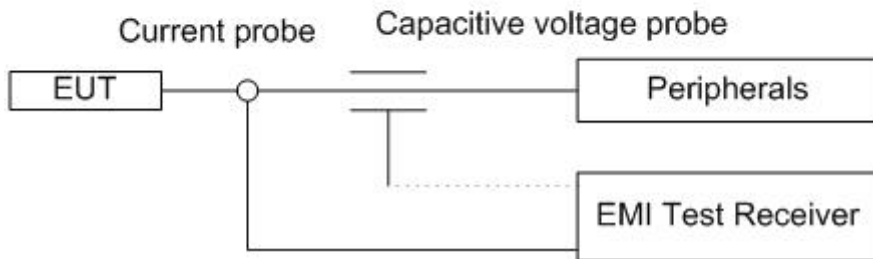
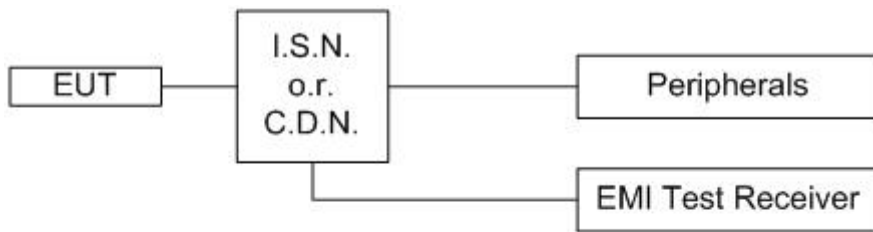



TEST PROCEDURE

The basic test procedure was in accordance with EN 55022.

The test procedure is performed in a 4m × 3m × 2.4m (L×W×H) shielded room.

The EUT along with its peripherals were placed on a 1.0m (W) × 1.5m (L) and 0.8m in height wooden table and the EUT was adjusted to maintain a 0.4 meter space from a vertical reference plane.

The EUT was connected to power mains through a line impedance stabilization network (LISN) which provides 50 ohm coupling impedance for measuring instrument and the chassis ground was bounded to the horizontal ground plane of shielded room. All peripherals were connected to the second LISN and the chassis ground also bounded to the horizontal ground plane of shielded room.

Mains ports:

The EUT was located so that the distance between the boundary of the EUT and the closest surface of the LISN is 0.8 m. Where a mains flexible cord was provided by the manufacturer shall be 1 m long, or if in excess of 1 m, the excess cable was folded back and forth as far as possible so as to form a bundle not exceeding 0.4 m in length.

Telecommunication ports:

The telecommunication port of the EUT was connected to the test receiver through the ISN/Current Probe and communication in normal condition. ISN shall be nominally 0.8 m from the EUT and bounded to a ground reference plane.

Conducted emission were investigated over the frequency range from 0.15 MHz to 30 MHz using a receiver, where the resolution bandwidth of the receiver is set as 9 kHz at frequency range from 0.15 MHz to 30 MHz.



TEST RESULTS

Mains Ports

Test Model	F208B	Test By	Alan Wu
Test Mode	Normal Operating	Test Date	2014/01/06
		Temp. & Humidity	21 °C, 54%

LINE

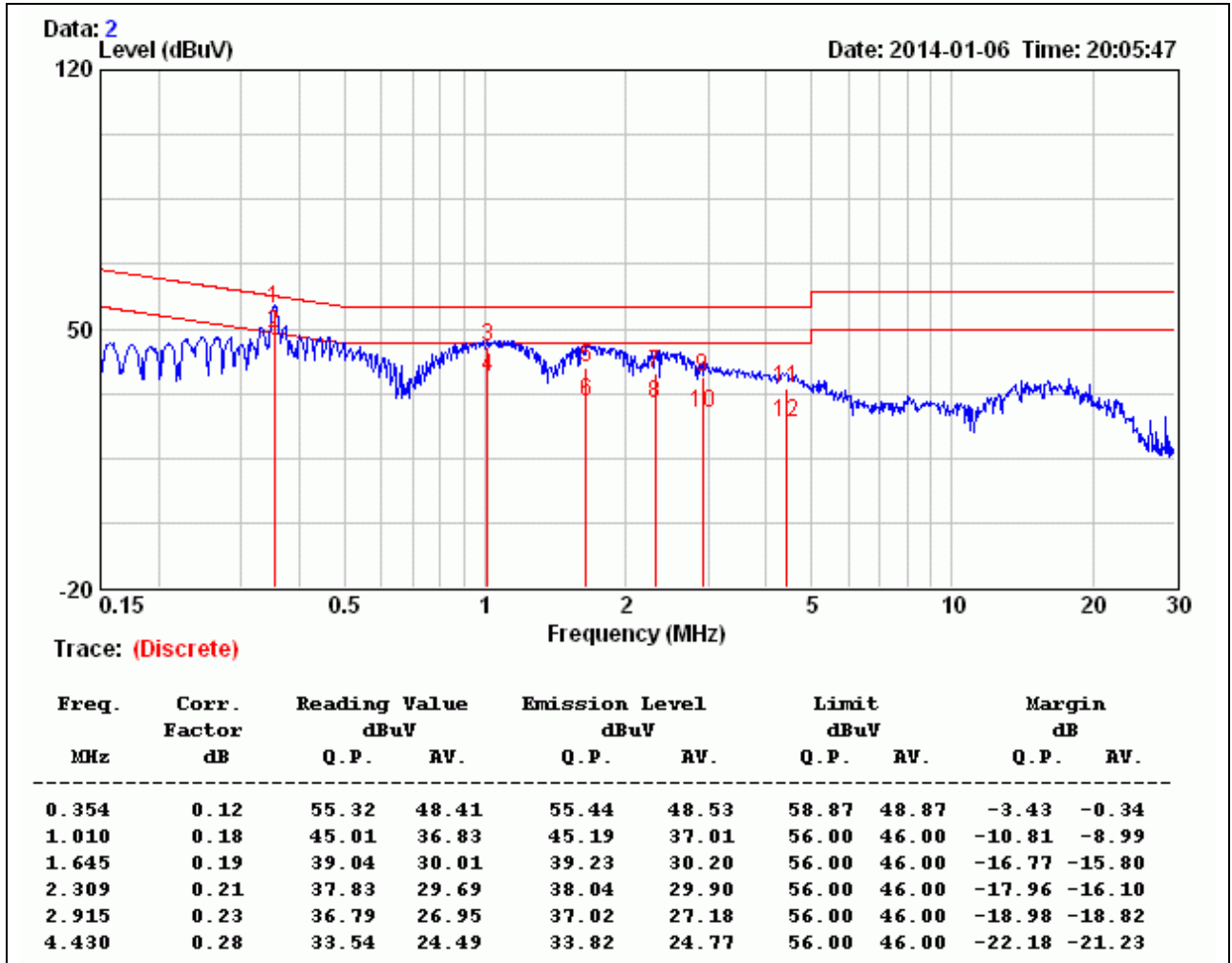

Remark:

1. Correction Factor = Insertion loss + Cable loss
2. Emission level = Reading Value + Correction factor
3. Margin value = Emission level – Limit value



Test Model	F208B	Test By	Alan Wu
Test Mode	Normal Operating	Test Date	2014/01/06
		Temp. & Humidity	21 °C, 54%

NEUTRAL

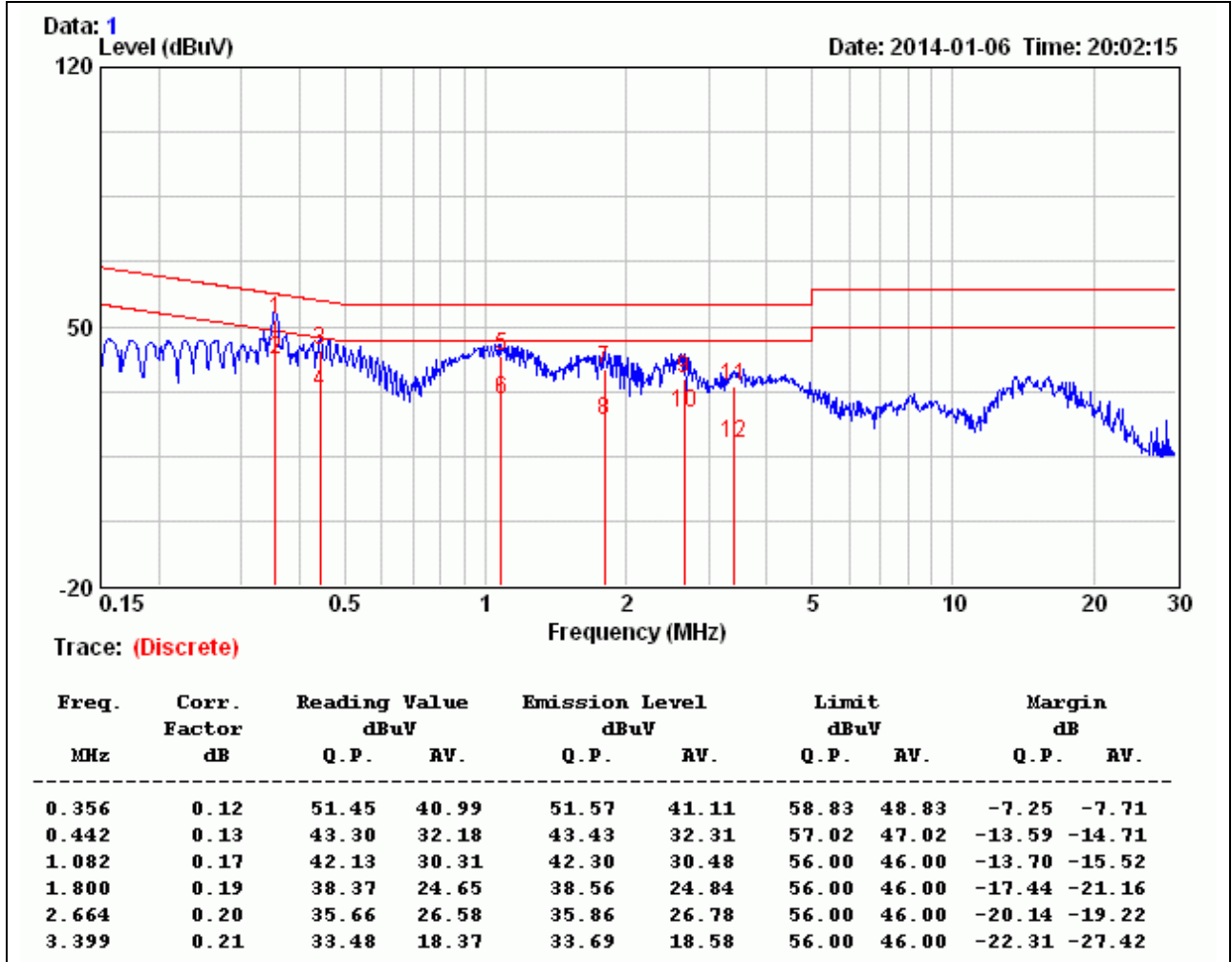

Remark:

1. Correction Factor = Insertion loss + Cable loss
2. Emission level = Reading Value + Correction factor
3. Margin value = Emission level – Limit value



Telecommunication Ports

Test Model	F208B	Test By	Alan Wu
Test Mode	LAN - 10Mbps	Test Date	2014/01/06
		Temp. & Humidity	21°C, 54%

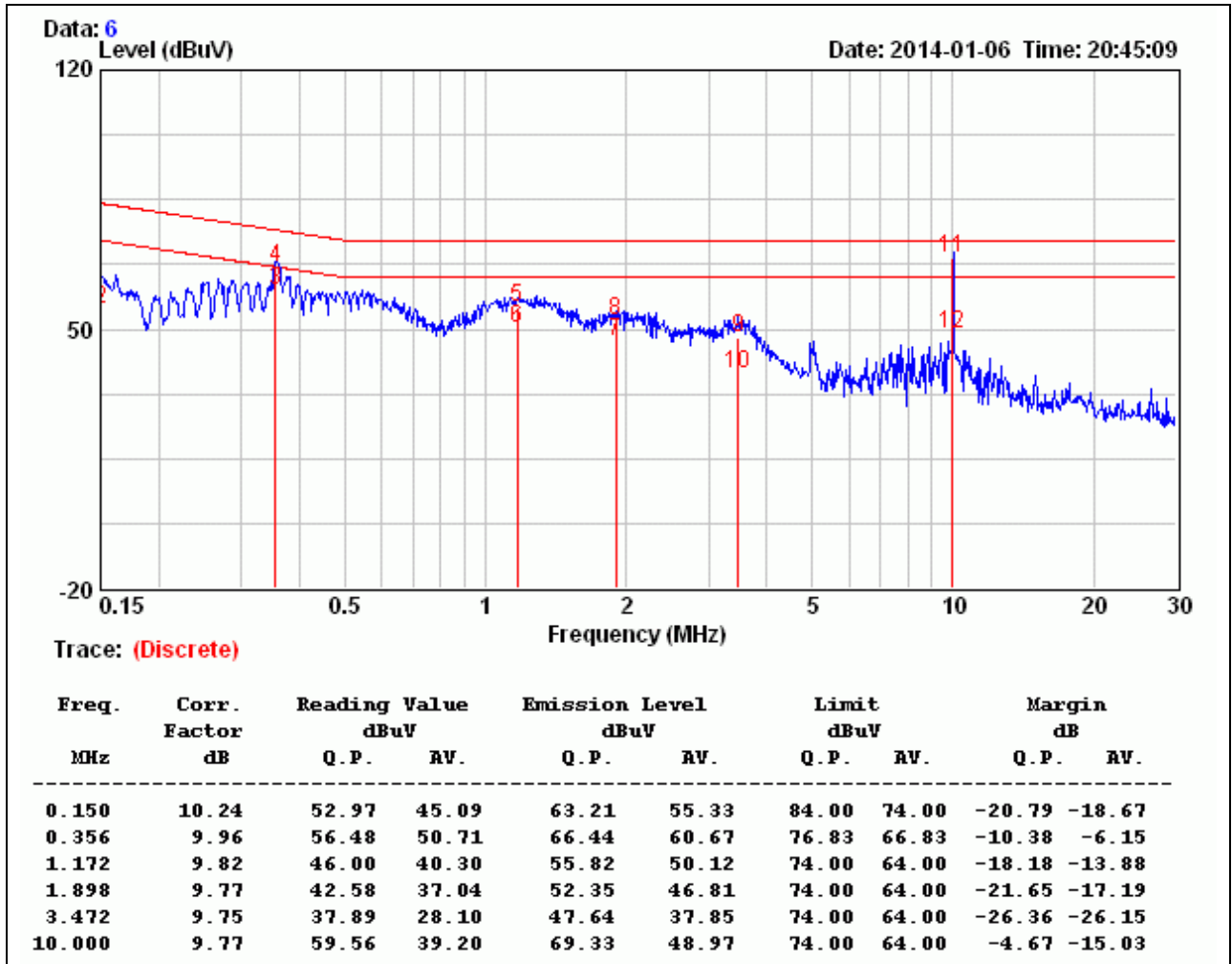

Remark:

1. Correction Factor = Insertion loss + Cable loss
2. Emission level = Reading Value + Correction factor
3. Margin value = Emission level – Limit value



Test Model	F208B	Test By	Alan Wu
Test Mode	LAN - 100Mbps	Test Date	2014/01/06
		Temp. & Humidity	21 °C, 54%

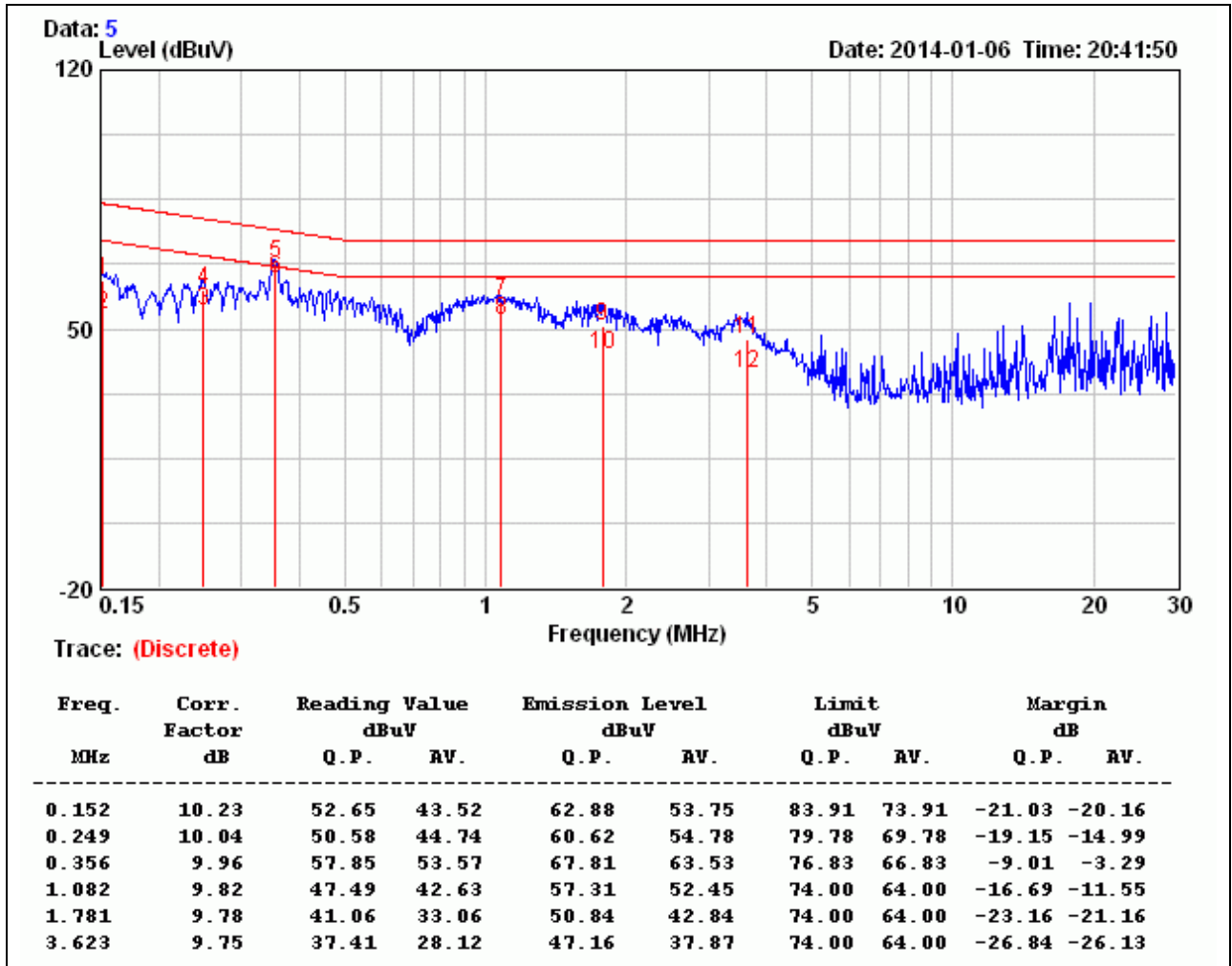

Remark:

1. Correction Factor = Insertion loss + Cable loss
2. Emission level = Reading Value + Correction factor
3. Margin value = Emission level – Limit value



7.3 HARMONIC CURRENT EMISSION

LIMITS

(1) Limits For Class A Equipment Disturbance Voltage Limits At Mains Terminals

Harmonic Order (n)	Maximum Permissible Harmonic Current (A)
Odd Harmonics	
3	2.30
5	1.14
7	0.77
9	0.40
11	0.33
13	0.21
15 N 39	0.15*15/N
Even Harmonics	
2	1.08
4	0.43
6	0.30
8 n 40	0.23*8/n

(2) Limits for Class B equipment

For Class B equipment, the harmonic of the input current shall not exceed the maximum permissible values given in table that is the limit of Class A multiplied by a factor of 1.5.

(3) Limits For Class C Equipment

Harmonic order (n)	Maximum permissible harmonic current expressed as a percentage of the input current at fundamental frequency (%)
Odd Harmonics	
2	2
3	30*λ*
5	10
7	7
9	5
11 n 39	3
(odd harmonics only)	

Remark: *λ is the circuit power factor



(4) Limits For Class D Equipment

Harmonic order (n)	Maximum permissible harmonic current per watt (mA/W)	Maximum permissible Harmonic current (A)
3	3.4	2.30
5	1.9	1.14
7	1.0	0.77
9	0.5	0.40
11	0.35	0.33
13 n 39 (odd harmonics only)	3.85/n	See Table 1

Remark: *λ is the circuit power factor

TEST EQUIPMENT

Name of Equipment	Manufacturer	Model	Serial Number	Calibration Due
Harmonics & Flicker Test System	EMC PARTNER	HARMONIC-1000	071	01/10/2014

Remark: Each piece of equipment is scheduled for calibration once a year.

TEST SETUP

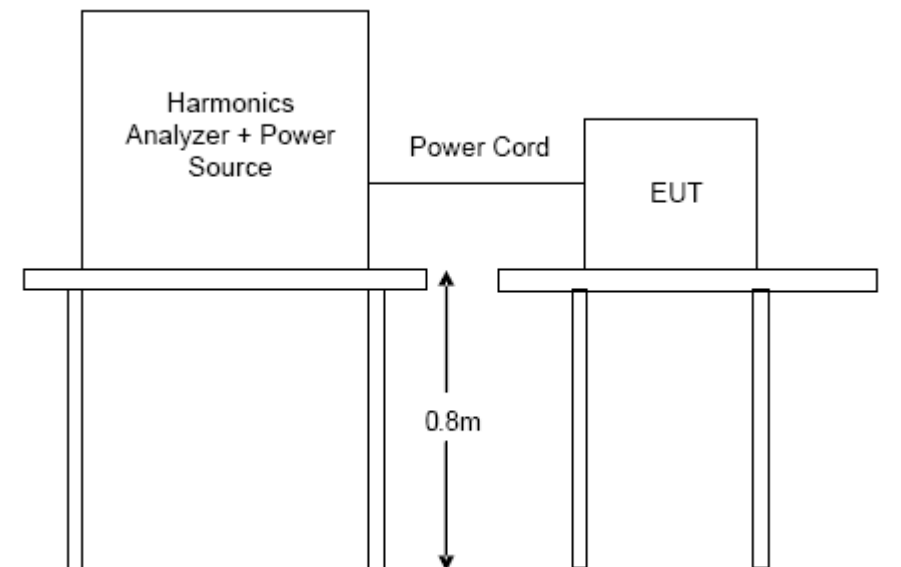



TEST PROCEDURE

The basic test procedure was in accordance with EN 61000-3-2.

The EUT was placed on the top of a wooden table 0.8 meters above the ground and operated to produce the maximum harmonic components under normal operating conditions for each successive harmonic component in turn.

The classification of EUT is according to section 5 of EN 61000-3-2.

The EUT is classified as follows:

Class A: Balanced three-phase equipment, Household appliances excluding equipment as Class D, Tools excluding portable tools, Dimmers for incandescent lamps, audio equipment, equipment not specified in one of the three other classes.

Class B: Portable tools; Arc welding equipment which is not professional equipment.

Class C: Lighting equipment.

Class D: Equipment having a specified power less than or equal to 600 W of the following types: Personal computers and personal computer monitors and television receivers.

The correspondent test program of test instrument to measure the current harmonics emanated from EUT is chosen. The measure time shall be not less than the time necessary for the EUT to be exercised.



TEST RESULTS

Ambient Temperature	22 °C	Test By	Alan Wu
Relative Humidity	52 %	Test Date	2014/01/06
Atmospheric Pressure	1012 mbar	Test Model	F208B

Urms = 230.3V Freq = 49.987 Range: 0.25 A
 Irms = 0.012A Ipk = 0.069A cf = 5.578
 P = 1.448W S = 2.868VA pf = 0.505
 THDi = 177 % THDu = 0.10 % Class A

Test completed, Result: PASSED

Order	Freq. [Hz]	Iavg [A]	Irms [A]	Imax [A]	Limit [A]	Status
1	50	0.0061	0.0063	0.0063		
2	100	0.0000	0.0007	0.0010	1.0800	
3	150	0.0000	0.0039	0.0040	2.3000	
4	200	0.0000	0.0007	0.0010	0.4300	
5	250	0.0000	0.0038	0.0039	1.1400	
6	300	0.0000	0.0007	0.0009	0.3000	
7	350	0.0000	0.0037	0.0038	0.7700	
8	400	0.0000	0.0007	0.0009	0.2300	
9	450	0.0000	0.0036	0.0036	0.4000	
10	500	0.0000	0.0007	0.0008	0.1840	
11	550	0.0000	0.0034	0.0034	0.3300	
12	600	0.0000	0.0007	0.0008	0.1533	
13	650	0.0000	0.0032	0.0032	0.2100	
14	700	0.0000	0.0006	0.0007	0.1314	
15	750	0.0000	0.0030	0.0030	0.1500	
16	800	0.0000	0.0006	0.0007	0.1150	
17	850	0.0000	0.0027	0.0027	0.1324	
18	900	0.0000	0.0006	0.0006	0.1022	
19	950	0.0000	0.0025	0.0025	0.1184	
20	1000	0.0000	0.0005	0.0006	0.0920	
21	1050	0.0000	0.0022	0.0022	0.1071	
22	1100	0.0000	0.0005	0.0005	0.0836	
23	1150	0.0000	0.0019	0.0019	0.0978	
24	1200	0.0000	0.0005	0.0005	0.0767	
25	1250	0.0000	0.0016	0.0017	0.0900	
26	1300	0.0000	0.0005	0.0005	0.0708	
27	1350	0.0000	0.0014	0.0014	0.0833	
28	1400	0.0000	0.0004	0.0004	0.0657	
29	1450	0.0000	0.0012	0.0012	0.0776	
30	1500	0.0000	0.0004	0.0004	0.0613	
31	1550	0.0000	0.0009	0.0010	0.0726	
32	1600	0.0000	0.0004	0.0004	0.0575	
33	1650	0.0000	0.0007	0.0008	0.0682	
34	1700	0.0000	0.0004	0.0004	0.0541	
35	1750	0.0000	0.0006	0.0006	0.0643	
36	1800	0.0000	0.0004	0.0004	0.0511	
37	1850	0.0000	0.0005	0.0005	0.0608	
38	1900	0.0000	0.0003	0.0003	0.0484	
39	1950	0.0000	0.0004	0.0004	0.0577	
40	2000	0.0000	0.0003	0.0003	0.0460	

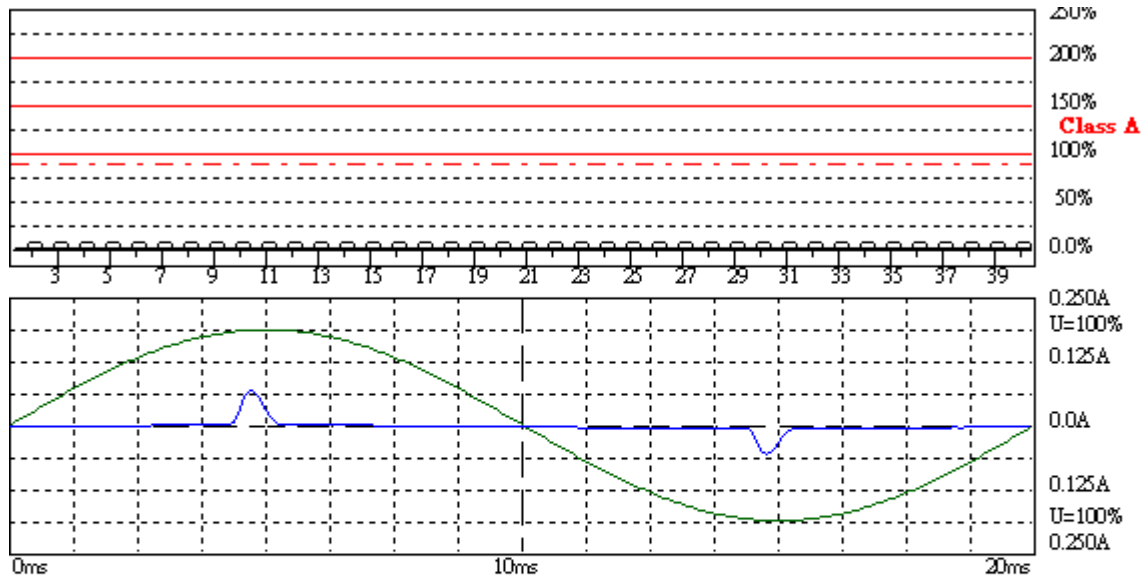

Harmonic Emission - IEC 61000-3-2 , EN 61000-3-2 , (EN60555-2)

2014/1/6 15:09:38

U_{rms} = 230.3 V P = 1.448 W THC = 0.011 A Range: 0.25 A
I_{rms} = 0.012 A pf = 0.505 V_{-nom}: 230 V

Test completed, Result: PASSED

Alan 22C 52H 1012M

BAR-1000 EMC-Printer



7.4 VOLTAGE FLUCTUATION AND FLICKER

LIMITS

Test item	Limit	Remark
Pst	1.0	Pst means short-term flicker indicator.
Plt	0.65	Plt means long-term flicker indicator.
Tdt (ms)	500	Tdt means maximum time that dt exceeds 3.3 %.
dmax (%)	4%	dmax means maximum relative voltage change.
dc (%)	3.3%	dc means relative steady-state voltage change

TEST EQUIPMENT

Name of Equipment	Manufacturer	Model	Serial Number	Calibration Due
Harmonics & Flicker Test System	EMC PARTNER	HARMONIC-1000	071	01/10/2014

Remark: Each piece of equipment is scheduled for calibration once a year.

TEST SETUP

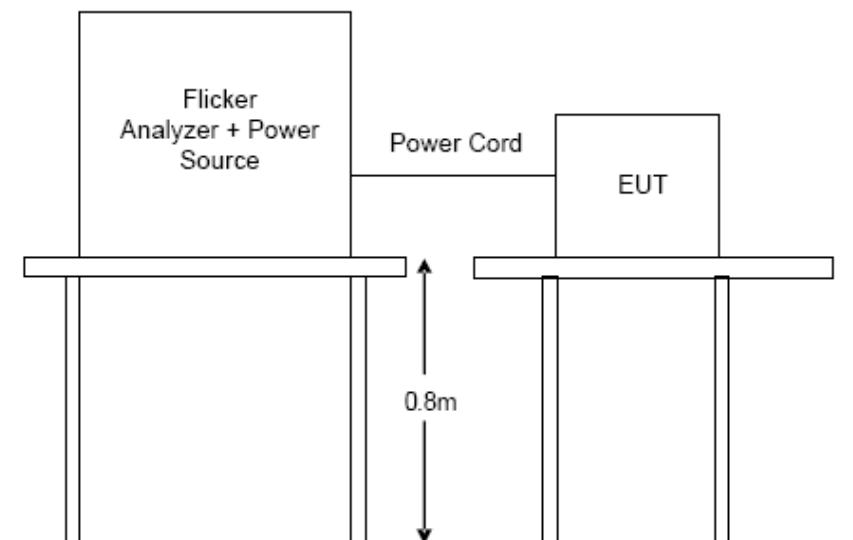

TEST PROCEDURE

The basic test procedure was in accordance with EN 61000-3-3.

The EUT was placed on the top of a wooden table 0.8 meters above the ground and operated to produce the most unfavorable sequence of voltage changes under normal operating conditions.

During the flick measurement, the measure time shall include that part of whole operation cycle in which the EUT produce the most unfavorable sequence of voltage changes. The observation period for short-term flicker indicator is 10 minutes and the observation period for long-term flicker indicator is 2 hours.



TEST RESULTS

Ambient Temperature	22 °C	Test By	Alan Wu
Relative Humidity	52 %	Test Date	2014/01/06
Atmospheric Pressure	1012 mbar	Test Model	F208B

Urms = 230.3V Freq = 50.000 Range: 0.25 A
 Irms = 0.013A Ipk = 0.071A cf = 5.567
 P = 1.460W S = 2.924VA pf = 0.499

LIN (Line Impedance Network) : L: 0.24ohm +j0.15ohm N: 0.16ohm +j0.10ohm

Limits : PIt : 0.65 Pst : 1.00
 dmax : 4.00 % dc : 3.30 %
 dtLim: 3.30 % dt>Lim: 500ms

Test completed, Result: PASSED

Flickermeter 1000-4-15 for 230V/50Hz

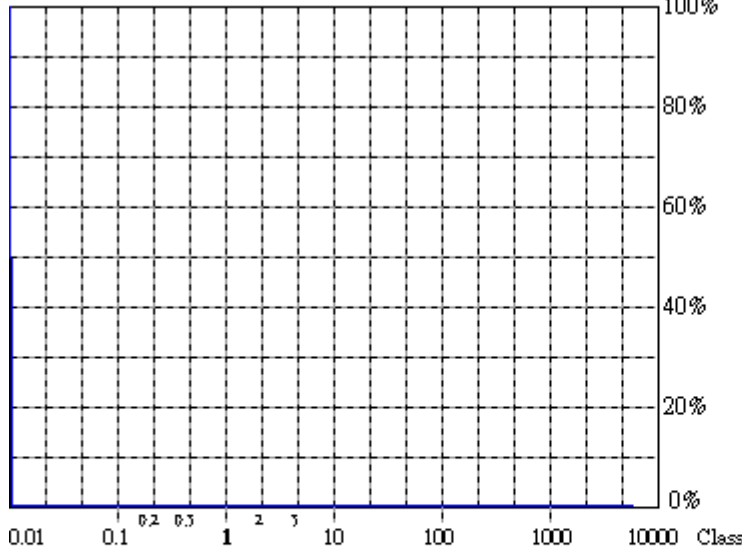

Actual Flicker (Fli): 0.00
Short-term Flicker (Pst): 0.07
 Limit (Pst): 1.00
Long-term Flicker (Plt): 0.07
 Limit (Plt): 0.65
Maximum Relative Volt. Change (dmax): 0.00%
 Limit (dmax): 4.00 %
Relative Steady-state Voltage Change (dc): 0.02%
 Limit (dc): 3.30 %
Maximum Interval exceeding 3.30% (dt): 0.00ms
 Limit (dt>Lim): 500ms

Flicker Emission - IEC 61000-3-3 , EN 61000-3-3 , (EN60555-3)

2014/1/6 14:57:27

Urms = 230.3 V P = 1.460 W
 Irms = 0.013 A pf = 0.499

Range: 0.25 A
 V-nom: 230 V

Test completed, Result: PASSED

Alan 22C 52H 1012M

B4 R-1000 EMC-Print



8. IMMUNITY TEST

PERFORMANCE CRITERIA DESCRIPTION

Criterion A	During and after the test the EUT shall continue to operate as intended without operator intervention. No degradation of performance or loss of function is allowed below a minimum performance level specified by the manufacturer when the EUT is used as intended. The performance level may be replaced by a permissible loss of performance. If the minimum performance level or the permissible performance loss is not specified by the manufacturer, then either of these may be derived from the product description and documentation, and by what the user may reasonably expect from the EUT if used as intended.
Criterion B	After the test, the EUT shall continue to operate as intended without operator intervention. No degradation of performance or loss of function is allowed, after the application of the phenomena below a performance level specified by the manufacturer, when the EUT is used as intended. The performance level may be replaced by a permissible loss of performance. During the test, degradation of performance is allowed. However, no change of operating state or stored data is allowed to persist after the test. If the minimum performance level (or the permissible performance loss) is not specified by the manufacturer, then either of these may be derived from the product description and documentation, and by what the user may reasonably expect from the EUT if used as intended.
Criterion C	During and after testing, a temporary loss of function is allowed, provided the function is self-recoverable, or can be restored by the operation of the controls or cycling of the power to the EUT by the user in accordance with the manufacturer's instructions. Functions, and/or information stored in non-volatile memory, or protected by a battery backup, shall not be lost.



8.1 ELECTROSTATIC DISCHARGE (ESD)

TEST SPECIFICATION

Product Standard	EN 55024:2010
Basic Standard	IEC 61000-4-2:2008
Discharge Impedance	330 ohm / 150 pF
Discharge Voltage	Air Discharge: 2, 4, 8 kV (Direct) Contact Discharge: 2, 4 kV (Direct/Indirect)
Polarity	Positive & Negative
Number of Discharge	Air Discharge: min. 10 times at single test point for each negative and positive polarity Contact Discharge: min. 200 times in total
Discharge Mode	Single Discharge 1 second minimum

TEST EQUIPMENT

Name of Equipment	Manufacturer	Model	Serial Number	Calibration Due
Electrostatic Discharge Simulator	NoiseKen	ESS-2000	0189C01569	08/29/2014

Remark: Each piece of equipment is scheduled for calibration once a year.

TEST SETUP

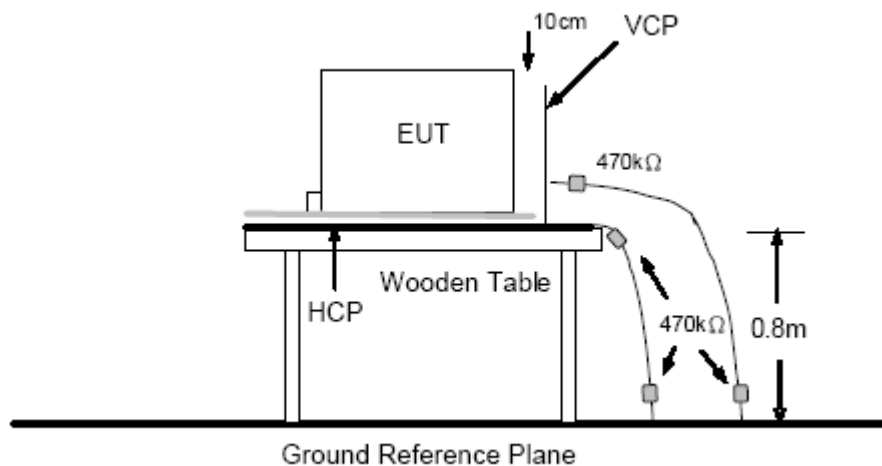



TEST PROCEDURE

The basic test procedure was in accordance with IEC 61000-4-2.

The EUT was located 0.1 m minimum from all side of the HCP (dimensions 1.6m x 0.8m). The support units were located another table 30 cm away from the EUT, but direct support unit was/were located at same location as EUT on the HCP and keep at a distance of 10 cm with EUT.

The time interval between two successive single discharges was at least 1 second.

Contact discharges were applied to the non-insulating coating, with the pointed tip of the generator penetrating the coating and contacting the conducting substrate.

Air discharges were applied with the round discharge tip of the discharge electrode approaching the EUT as fast as possible (without causing mechanical damage) to touch the EUT. After each discharge, the ESD generator was removed from the EUT and re-triggered for a new single discharge. The test was repeated until all discharges were complete.

At least ten single discharges (in the most sensitive polarity) were applied at the front edge of each HCP opposite the center point of each unit of the EUT and 0.1 meters from the front of the EUT. The long axis of the discharge electrode was in the plane of the HCP and perpendicular to its front edge during the discharge.

At least ten single discharges (in the most sensitive polarity) were applied to the center of one vertical edge of the Vertical Coupling Plane (VCP) in sufficiently different positions that the four faces of the EUT were completely illuminated. The VCP (dimensions 0.5m x 0.5m) was placed vertically to and 0.1 meters from the EUT.

TEST RESULTS

Ambient Temperature	22 °C	Test By	Alan Wu
Relative Humidity	52 %	Test Date	2014/01/06
Atmospheric Pressure	1009 mbar	Test Model	F208B ; F108X

Test Level	Polarity	Required Criterion				Performance Criterion				Result
		Air discharge	Contact discharge	HCP discharge	VCP discharge	Air discharge	Contact discharge	HCP discharge	VCP discharge	
2 kV	+	B	B	B	B	B	B	A	B	PASS
	-	B	B	B	B	B	B	A	B	PASS
4 kV	+	B	B	B	B	B	B	A	B	PASS
	-	B	B	B	B	B	B	A	B	PASS
8 kV	+	B	NR	NR	NR	B	NR	NR	NR	PASS
	-	B	NR	NR	NR	B	NR	NR	NR	PASS

Remark: NR means there is no requirement.



THE TESTED POINTS OF EUT

Model : F208B

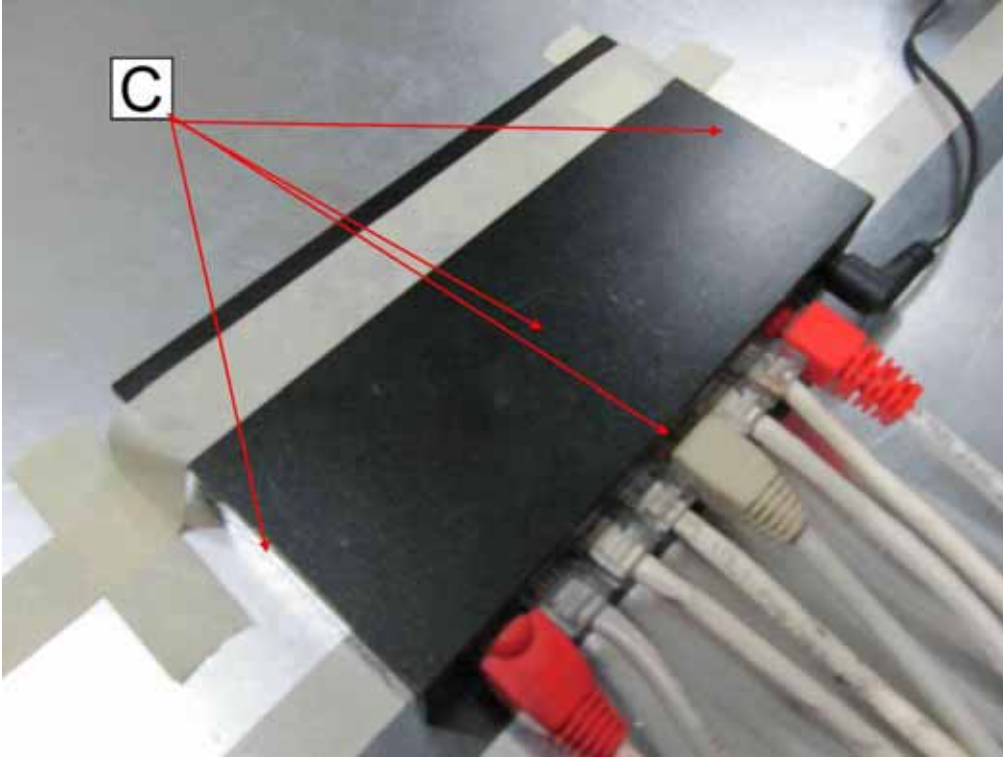

C : Contact Discharge

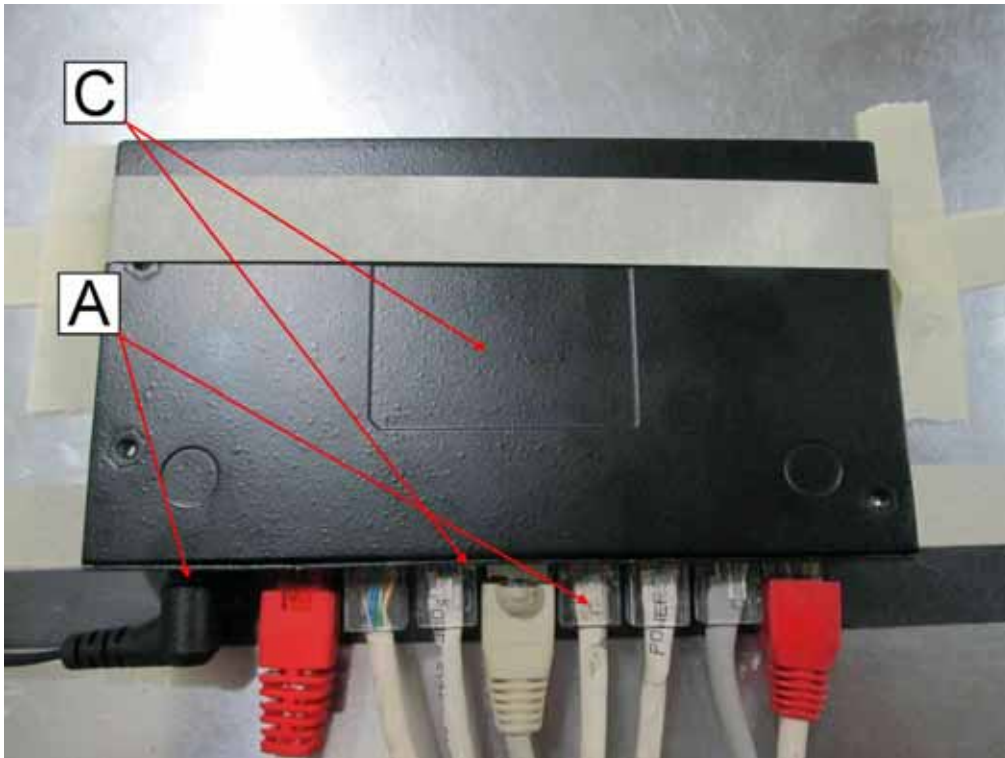

A : Air Discharge, C : Contact Discharge



Model : F108X

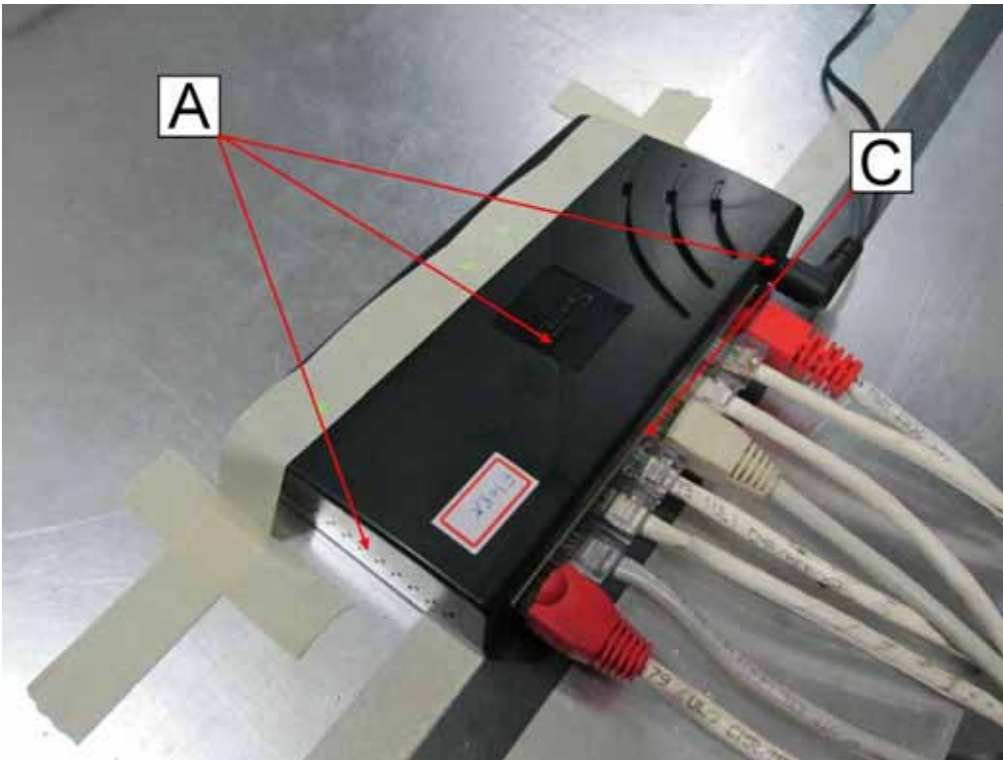

A : Air Discharge, C : Contact Discharge

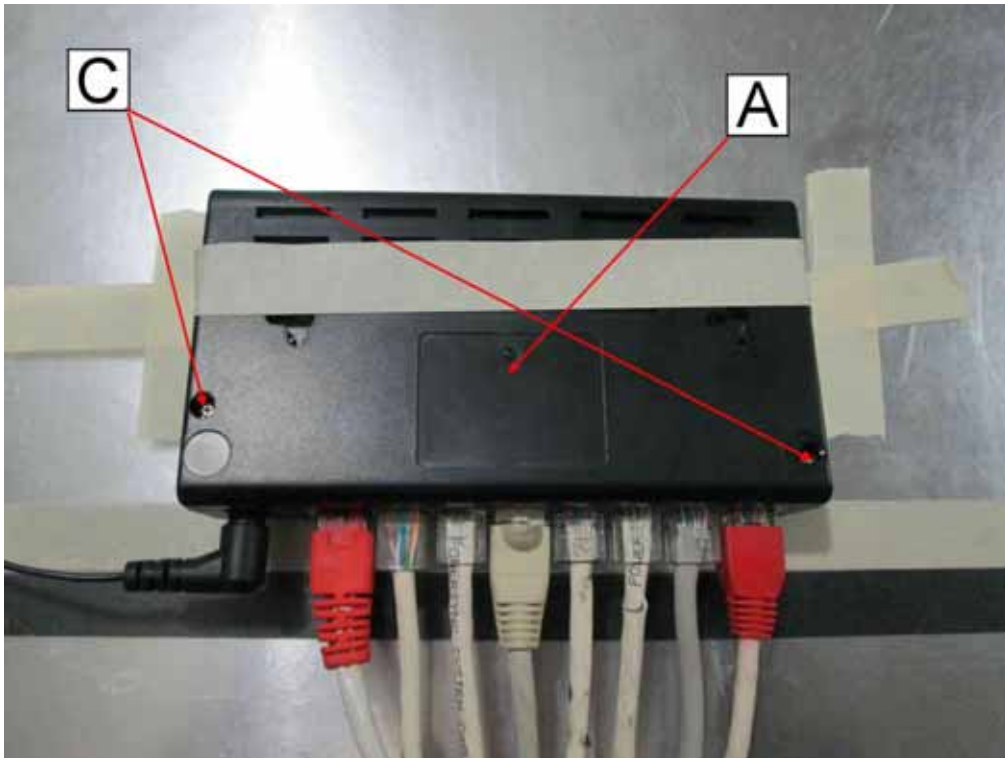

A : Air Discharge, C : Contact Discharge



8.2 RF ELECTROMAGNETIC FIELD (RS)

TEST SPECIFICATION

Product Standard	EN 55024:2010
Basic Standard	IEC 61000-4-3:2006 + A1:2007 + A2:2010
Frequency Range	80 MHz ~ 1000 MHz
Field Strength	3 V/m
Modulation	1kHz Sine Wave, 80%, AM Modulation
Frequency Step	1 % of preceding frequency value
Polarity of Antenna	Horizontal and Vertical
Test Distance	3 m
Antenna Height	1.5m

TEST EQUIPMENT

Name of Equipment	Manufacturer	Model	Serial Number	Calibration Due
Calibration of Field	N/A	Chamber#RS	80-1000MHz	04/15/2014
Signal Generator	Agilent	E4421B	MY43350597	05/30/2014
Electric Field Probe	AR	FL7006	0338955	04/08/2014
RF Power Meter	Boonton	4242-01-02	14357	03/11/2014
Amplifier	AR	500W1000A	320994	N.C.R.
Direction Coupler	AR	DC6180A	312189	N.C.R.
Broadband Antenna	AR	AT1080	311819	N.C.R.
Thermo-Hygro meter	TFA	N/A	NO.6	11/11/2014
Software	Emcware Ver. 2.6.0.16			

Remark: 1. Each piece of equipment is scheduled for calibration once a year.

2. N.C.R = No Calibration Request.

3. This is CCS-Xindian test equipment.



TEST SETUP

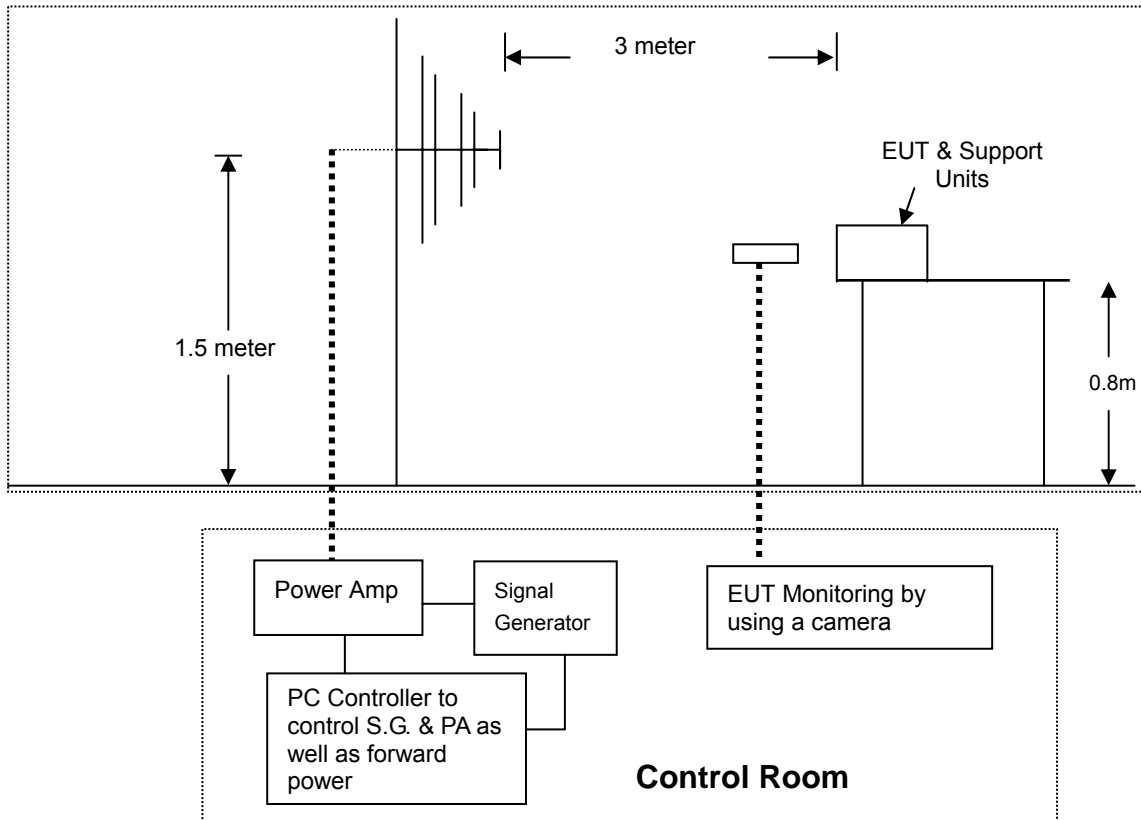

TEST PROCEDURE

The test procedure was in accordance with IEC 61000-4-3.

The testing was performed in a fully anechoic chamber. The transmit antenna was located at a distance of 3 meters from the EUT.

The frequency range is swept from 80 MHz to 1000 MHz, with the signal 80% amplitude modulated with a 1kHz sine-wave. The rate of sweep did not exceed 1.5×10^{-3} decade/s, where the frequency range is swept incrementally, the step size was 1% of preceding frequency value.

The dwell time at each frequency shall be not less than the time necessary for the EUT to be able to respond.

The test was performed with the EUT exposed to both vertically and horizontally polarized fields on each of the four sides.



TEST RESULTS

Ambient Temperature	17 °C	Test By	Mike Xie
Relative Humidity	49 %	Test Date	2014/01/08
Atmospheric Pressure	1001 mbar	Test Model	F208B ; F108X

Frequency (MHz)	Polarity	Azimuth (°)	Field Strength (V/m)	Required Criterion	Performance Criterion	Result
80 ~ 1000	V&H	0	3	A	A	PASS
80 ~ 1000	V&H	90	3	A	A	PASS
80 ~ 1000	V&H	180	3	A	A	PASS
80 ~ 1000	V&H	270	3	A	A	PASS

Remark: This test item is test by CCS-Xindian.



8.3 FAST TRANSIENTS COMMON MODE (EFT)

TEST SPECIFICATION

Product Standard	EN 55024:2010
Basic Standard	IEC 61000-4-4:2012
Test Voltage	AC Power Port: 1kV DC Power Port: 0.5kV Signal Ports and Telecommunication Ports: 0.5kV
Polarity	Positive & Negative
Impulse Frequency	5 kHz
Impulse Wave-shape	5/50 ns
Burst Duration	15 ms
Burst Period	300 ms
Test Duration	Not less than 1 min.

TEST EQUIPMENT

Name of Equipment	Manufacturer	Model	Serial Number	Calibration Due
EMC Immunity Tester	EMC Partner	TRANSIENT 2000	1117	03/10/2014
Capacitive Clamp	EMC Partner	CN-EFT1000	589	07/25/2014
Software	Genecs Ver. 3.27			

- Remark:** 1. Each piece of equipment is scheduled for calibration once a year.
 2. N.C.R = No Calibration Request.
 3. This is CCS-Xindian test equipment.



TEST SETUP

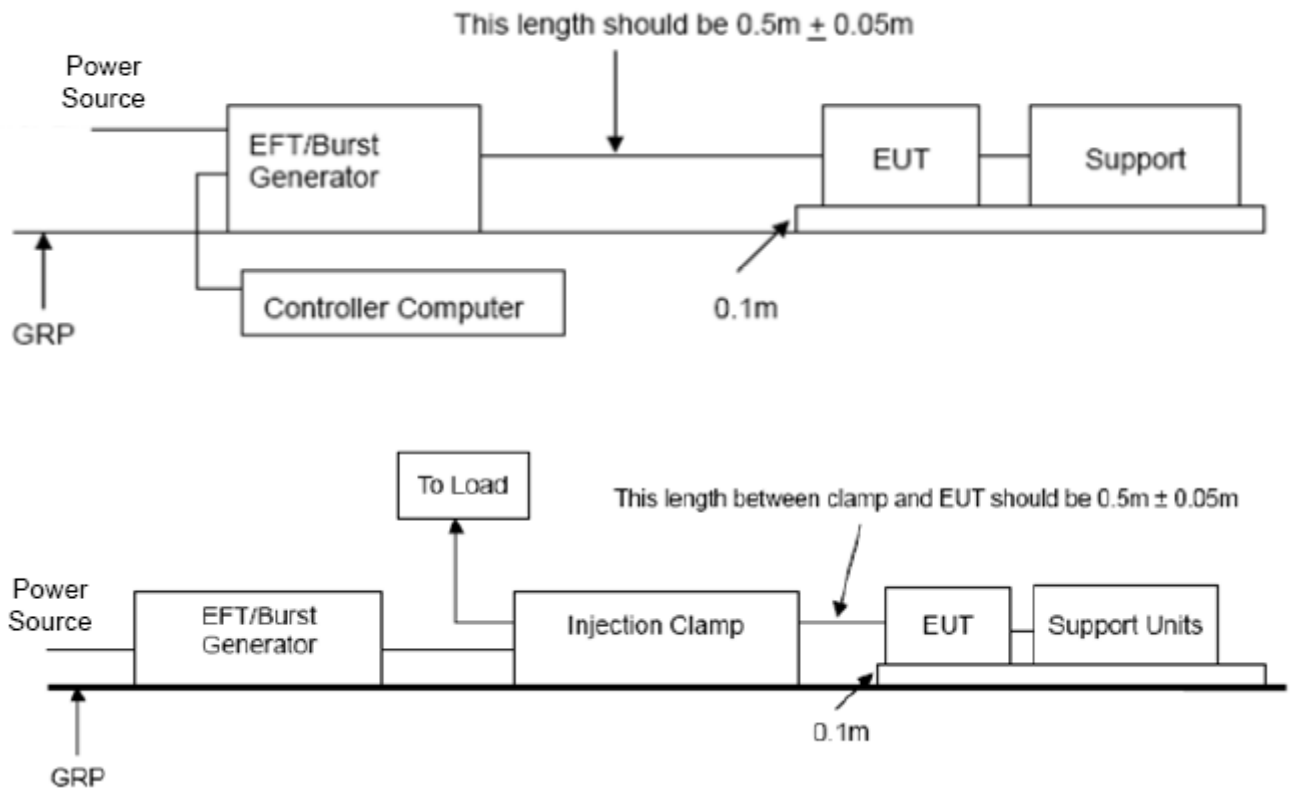

TEST PROCEDURE

The test procedure was in accordance with IEC 61000-4-4.

The equipment was placed on a insulation which is 0.1 m above a ground reference plane.

The minimum area of the ground reference plane is 1 m *1 m, and 0.65 mm thick min, and projected beyond the EUT by at least 0.1 m on all sides.

Test on I/O and communication ports: The EFT/B interference signal is through coupling clamp device couples to the signal and control lines of the EUT with burst noise.

Test on power supply ports: The EUT is connected to the power mains through a coupling device that directly couples the EFT/B interference signal. The length of the signal and power lines between the coupling device and the EUT is 0.5 m.

Fast transient are carried out during 1 min with a positive polarity and during 1 min with negative polarity.



TEST RESULTS

Ambient Temperature	18 °C	Test By	Kevin Wang
Relative Humidity	57 %	Test Date	2014/01/08
Atmospheric Pressure	1009 mbar	Test Model	F200B

Test Point	Polarity	Test Level (kV)	Required Criterion	Performance Criterion	Result
<input checked="" type="checkbox"/> L	+/-	1	B	A	PASS
<input checked="" type="checkbox"/> N	+/-	1	B	A	PASS
<input type="checkbox"/> PE	+/-	1	B	NR	NR
<input checked="" type="checkbox"/> L+N	+/-	1	B	A	PASS
<input type="checkbox"/> L+PE	+/-	1	B	NR	NR
<input type="checkbox"/> N+PE	+/-	1	B	NR	NR
<input type="checkbox"/> L+N+PE	+/-	1	B	NR	NR

Test Point	Polarity	Test Level (kV)	Required Criterion	Performance Criterion	Result
<input checked="" type="checkbox"/> Signal Ports and Telecommunication Ports(RJ-45)	+/-	0.5	B	A	PASS

Remark: 1. NR means there is no requirement.
2. This test item is test by CCS-Xindian.

**8.4 SURGE****TEST SPECIFICATION**

Product Standard	EN 55024:2010
Basic Standard	IEC 61000-4-5:2005
Wave-Shape	Combination Wave (for power lines) 1.2/50 μ s Open Circuit Voltage 8/20 μ s Short Circuit Current 10/700 μ s Wave (for signal lines) 10/700 μ s Open Circuit Voltage
Test Voltage	AC Power Port ~ line to line: 1kV, line to ground: 2kV DC Power Port ~ line to ground: 0.5kV Signal Ports and Telecommunication Ports ~ line to ground: 1kV (without primary protection) 4kV (with primary protection)
Surge Input/Output:	AC Power Port: L-N / L-PE / N-PE DC Power Port: L1-PE / L2-PE Telecommunication Ports: Tip + Ring to ground
Generator Source Impedance	AC Power Port: 2 ohm between networks 12 ohm between network and ground Telecommunication Ports: 40 ohm between network and ground
Polarity	Positive/Negative
Phase Angle	0 / 90 / 180 / 270
Pulse Repetition Rate	1 time / min. (maximum)
Number of Tests	5 positive and 5 negative at selected points



TEST EQUIPMENT

Name of Equipment	Manufacturer	Model	Serial Number	Calibration Due
EMC Immunity Tester	EMC Partner	TRANSIENT 2000	1117	03/10/2014
CDN	EMC Partner	CDN-UTP8	CDN-UTP8-1505	03/10/2014
Software	Genecs Ver. 3.27			

Remark: 1. Each piece of equipment is scheduled for calibration once a year.
 2. N.C.R = No Calibration Request.
 3. This is CCS-Xindian test equipment.

TEST SETUP

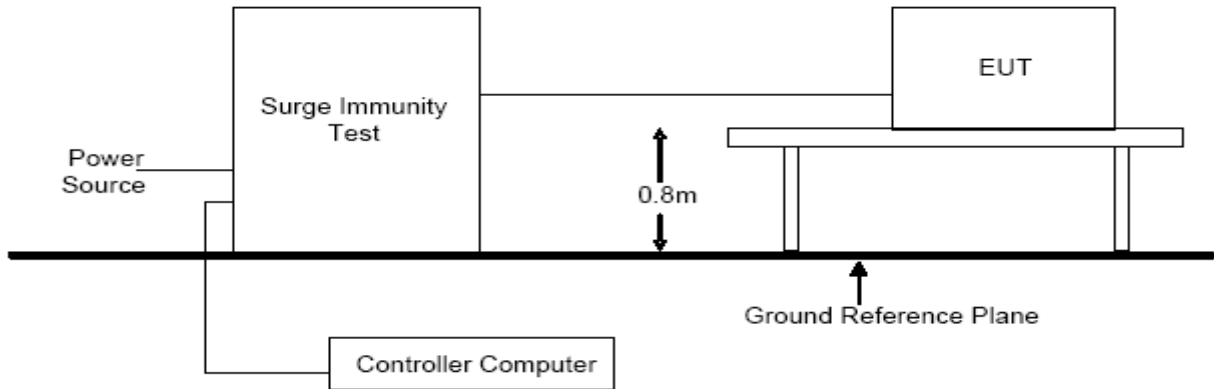

TEST PROCEDURE

The test procedure was in accordance with IEC 61000-4-5.

The EUT and its load are placed on a table that is 0.8 meter above a ground reference plane. The minimum area of the ground reference plane is 1 m *1 m, and 0.65 mm thick min, and projected beyond the EUT by at least 0.1 m on all sides. The length of power cord/interconnection line between the coupling device and the EUT shall be 2 m or less.

Test on Input AC Power ports:

The EUT is connected to the power mains through a coupling device that directly couples the Surge interference signal.

The surge noise shall be applied synchronized to voltage phase at 0°, 90°, 180°, 270° and the peak value of the a.c. voltage wave.



TEST RESULTS

Ambient Temperature	18 °C	Test By	Kevin Wang
Relative Humidity	57 %	Test Date	2014/01/08
Atmospheric Pressure	1009 mbar	Test Model	F208B

Test Point	Polarity	Test Level (kV)	Required Criterion	Performance Criterion	Result
<input checked="" type="checkbox"/> L-N	+/-	1	B	A	PASS
<input type="checkbox"/> L-PE	+/-	2	B	NR	NR
<input type="checkbox"/> N-PE	+/-	2	B	NR	NR

Test Point	Polarity	Test Level (kV)	Required Criterion	Performance Criterion	Result
<input checked="" type="checkbox"/> Signal Ports and Telecommunication Ports(RJ-45)	+/-	1	C	B	PASS

Remark: 1. NR means there is no requirement.
 2. This test item is test by CCS-Xindian.



8.5 CONDUCTED RADIO FREQUENCY DISTURBANCES (CS)

TEST SPECIFICATION

Product Standard	EN 55024:2010
Basic Standard	IEC 61000-4-6:2008
Frequency Range	0.15 MHz ~ 80 MHz
Voltage Level	3 Vrms
Modulation	1kHz Sine Wave, 80%, AM Modulation
Frequency Step	1 % of preceding frequency value
Dwell Time	3 seconds
Coupled cable	Power Mains, Unshielded
Coupling device	CDN-M2 (2 wires) / CDN-M3 (3 wires) CDN-T2/CDN-T4/EM Clamp (signal and control lines)

TEST EQUIPMENT

Name of Equipment	Manufacturer	Model	Serial Number	Calibration Due
CWS Generator	EM Test	CWS 500N1	V0395105080	10/02/2014
CDN (EUT)	Teseq	CDN M016	35820	06/21/2014
CDN	Teseq	CDN M016	35821	06/21/2014
CDN	Teseq	CDN T400A	25674	01/17/2014
CDN	Teseq	CDN T800	26155	02/04/2014
Attenuator	EMCI	SA3NL	10006F	N.C.R.
Software	icd.control Ver. 5.1.9			

- Remark:** 1. Each piece of equipment is scheduled for calibration once a year.
 2. N.C.R = No Calibration Request.
 3. This is CCS-Xindian test equipment.

TEST SETUP

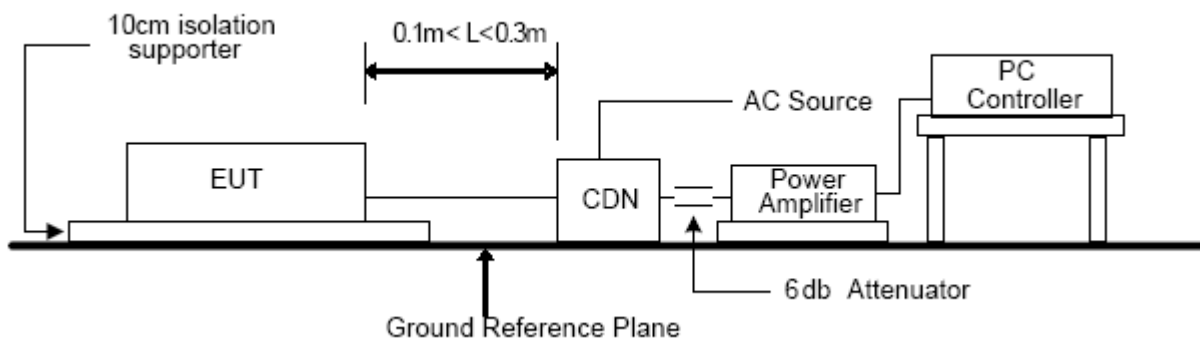



TEST PROCEDURE

The test procedure was in accordance with IEC 61000-4-6.

The EUT is placed on an insulating support of 0.1 m height above a ground reference plane. All cables exiting the EUT shall be supported at a height at least 30 mm above the ground reference plane.

Test on signal ports and telecommunication ports:

The disturbance signal is through a coupling and decoupling networks (CDN) or EM-clamp device couples to the signal and telecommunication lines of the EUT.

Test on DC and AC ports: The EUT is connected to the power mains through a coupling and decoupling networks for power supply lines. And directly couples the disturbances signal into EUT.

TEST RESULTS

Ambient Temperature	22 °C	Test By	Bonny Tsai
Relative Humidity	53 %	Test Date	2014/01/08
Atmospheric Pressure	1006 mbar	Test Model	F208B

Frequency (MHz)	Voltage Level (V)	Injection Method	Test port	Required Criterion	Performance Criterion	Result
0.15 ~ 80	3	<input checked="" type="checkbox"/> CDN-M2	<input checked="" type="checkbox"/> AC Input	A	A	PASS
		<input type="checkbox"/> CDN-M3	<input type="checkbox"/> DC Input			
0.15 ~ 80	3	EM Clamp	<input checked="" type="checkbox"/> Signal lines	A	A	PASS
			<input type="checkbox"/> Control lines			

Remark: 1. NR means there is no requirement.
2. This test item is test by CCS-Xindian.



8.6 POWER FREQUENCY MAGNETIC FIELDS (PFMF)

TEST SPECIFICATION

Product Standard	EN 55024:2010
Basic Standard	IEC 61000-4-8:2009
Frequency Range	50/60Hz
Field Strength	1 A/m
Observation Time	1 minute
Inductance Coil	Rectangular type, 1mx1m

TEST EQUIPMENT

Name of Equipment	Manufacturer	Model	Serial Number	Calibration Due
Power Frequency Magnetic Field	DANA TORINO-ITALY	DAS-G60 DAS 1 S 1000	96DA6-101	10/24/2014
F.W.BELL	Triaxial ELF Magnetic Field Meter	4190	1222007	06/18/2014

Remark: Each piece of equipment is scheduled for calibration once a year.

TEST SETUP

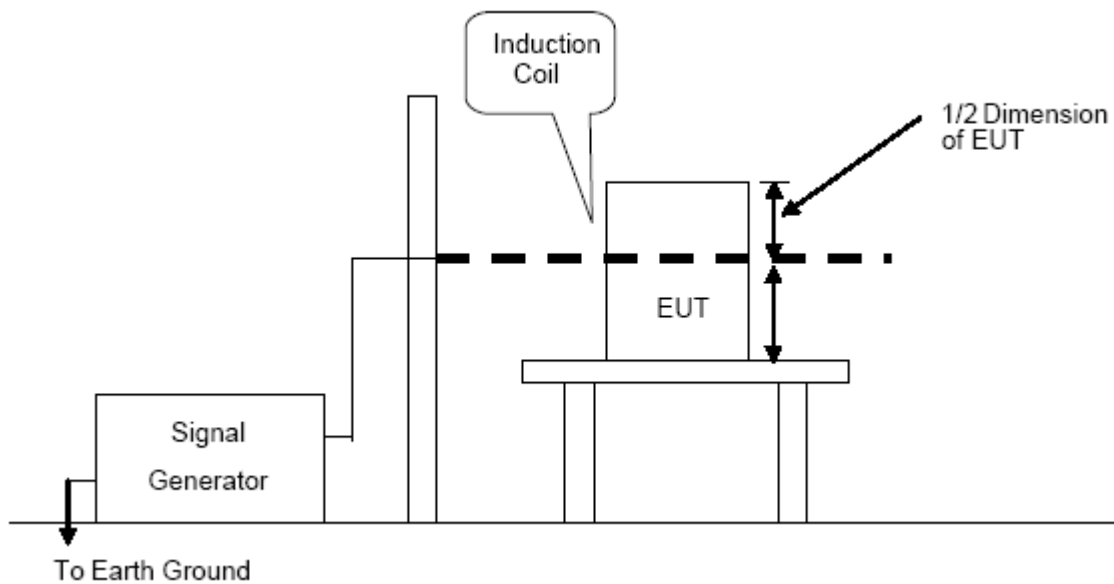



TEST PROCEDURE

The test procedure was in accordance with IEC 61000-4-8.

The equipment was configured and connected to satisfy its functional requirements.

The equipment was placed on a table which is 0.8 m above a metal ground plane measured at least 1 m x 1 m min.

The cables supplied or recommended by the equipment manufacturer shall be used. 1 meter of all cables used shall be exposed to the magnetic field.

The equipment shall be subjected to the test magnetic field by using the induction coil of standard dimension (1 m x 1 m). The induction coil shall then be rotated by 90 degrees in order to expose the EUT to the test field with different orientations.

TEST RESULTS

Ambient Temperature	22 °C	Test By	Alan Wu
Relative Humidity	52 %	Test Date	2014/01/06
Atmospheric Pressure	1009 mbar	Test Model	F208B ; F108X

Direction	Field Strength (A/m)	Required Criterion	Performance Criterion	Results
X	1	A	A	PASS
Y	1	A	A	PASS
Z	1	A	A	PASS



8.7 VOLTAGE DIPS & VOLTAGE INTERRUPTIONS (DIP)

TEST SPECIFICATION

Product Standard	EN 55024:2010
Basic Standard	IEC 61000-4-11:2004
Test duration time	Minimum three test events in sequence
Interval between event	Minimum 10 seconds
Angle	0~360 degree
Step	45 degree

TEST EQUIPMENT

Name of Equipment	Manufacturer	Model	Serial Number	Calibration Due
EMC Immunity Tester	EMC Partner	TRANSIENT 2000	1117	03/10/2014
AC/DC Clamp Meter	Lutron	CM-9930R	1.200121	06/04/2014
Software	Genecs Ver. 3.27			

- Remark:** 1. Each piece of equipment is scheduled for calibration once a year.
2. N.C.R = No Calibration Request.
3. This is CCS-Xindian test equipment.

TEST SETUP

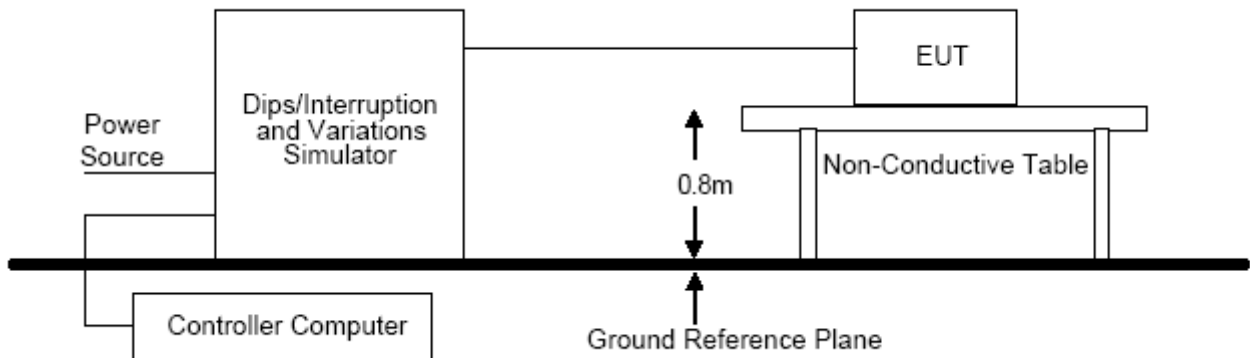



TEST PROCEDURE

The test procedure was in accordance with IEC 61000-4-11.

The EUT and its load are placed on a table that is 0.8 meter above a ground reference plane. The minimum area of the ground reference plane is 1 m *1 m, and 0.65 mm thick min, and projected beyond the EUT by at least 0.1 m on all sides. The cables supplied or recommended by the equipment manufacturer shall be used.

The EUT shall be tested for voltage dip of supplied voltage and duration periods, with a sequence of three voltage reduction with intervals of 10 seconds.

Voltage phase shifting are shall occur at 0, 45, 90, 135, 180, 225, 270, 315 degrees.

TEST RESULTS

Ambient Temperature	18 °C	Test By	Kevin Wang
Relative Humidity	57 %	Test Date	2014/01/08
Atmospheric Pressure	1009 mbar	Test Model	F208B

Voltage Reduction (%)	Test Duration (Periods)	Required Criterion	Performance Criterion	Results
>95	0.5	B	A	PASS
30	25	C	A	PASS
>95	250	C	B	PASS

Remark: This test item is test by CCS-Xindian.



APPENDIX SETUP PHOTOS

RADIATED EMISSION SETUP

Below 1 GHz





CONDUCTED EMISSION SETUP

Mains Ports

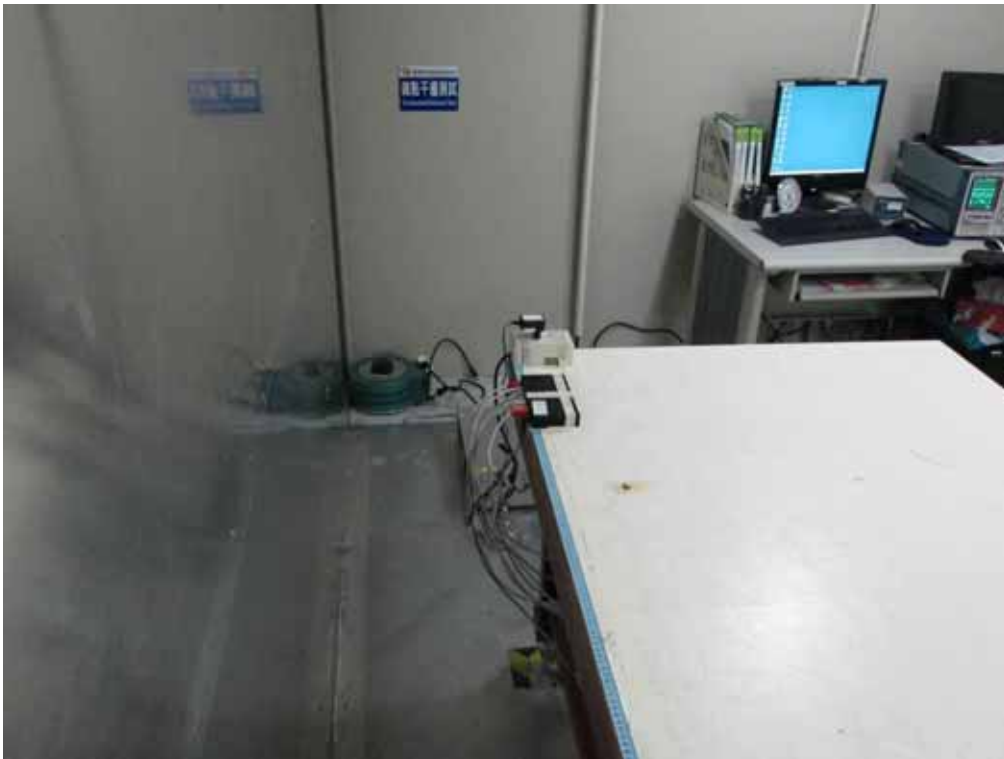



Telecommunication Ports

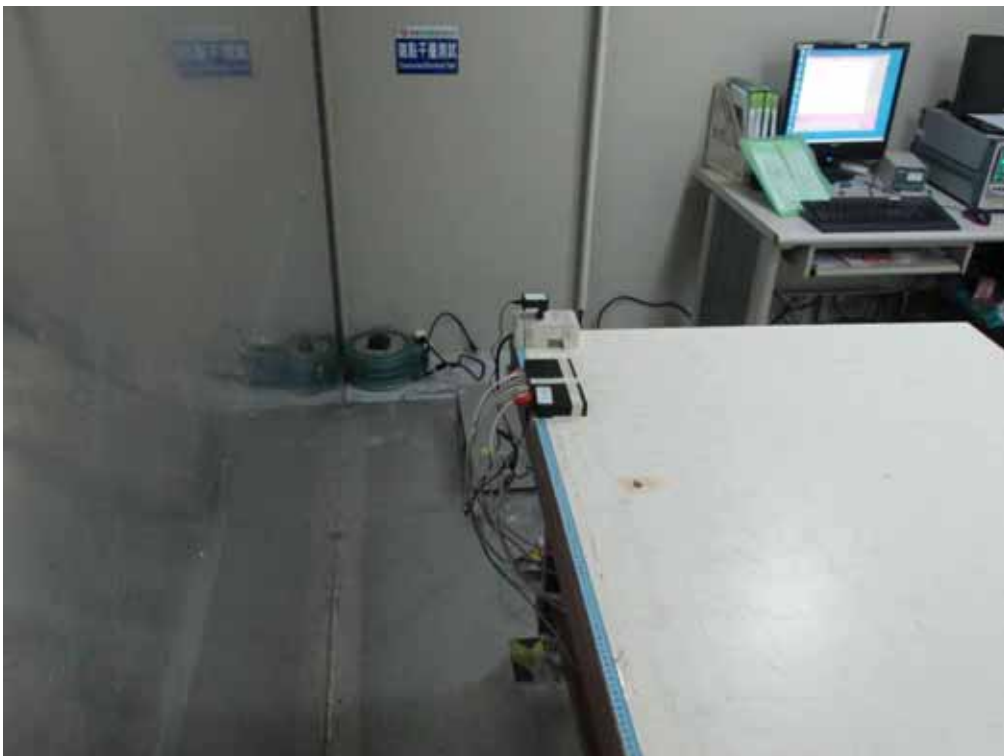
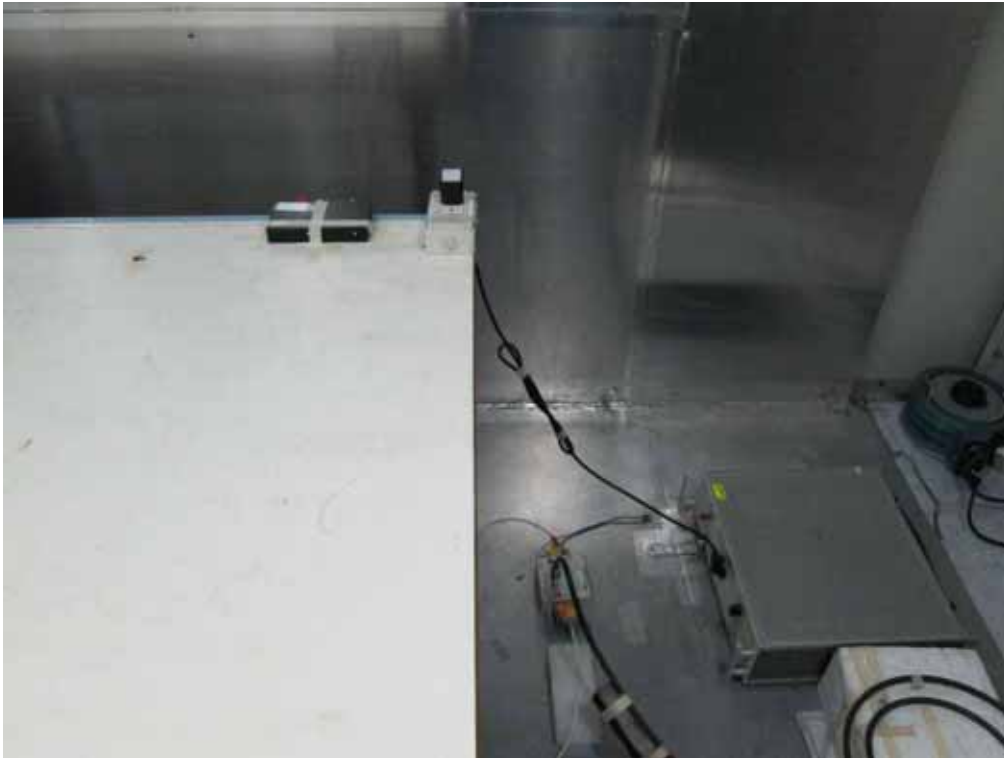



HARMONIC CURRENT EMISSIONS SETUP



VOLTAGE FLUCTUATION AND FLICKER SETUP





ELECTROSTATIC DISCHARGE SETUP

Model : F208B



Model : F108X





RF ELECTROMAGNETIC FIELD SETUP

Model : F208B



Model : F108X





FAST TRANSIENTS COMMON MODE SETUP

Input a.c. Power port



Signal Port





SURGE SETUP

Input a.c. Power port



Signal Port





CONDUCTED RADIO FREQUENCY DISTURBANCES SETUP

Input a.c. Power port

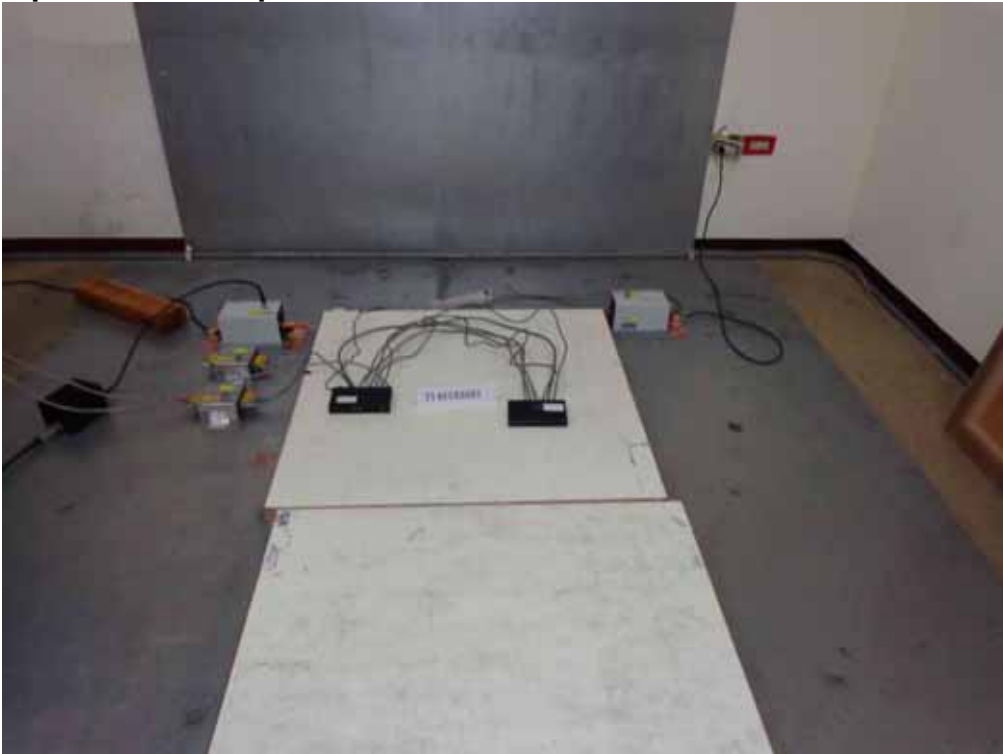

Signal Port





POWER FREQUENCY MAGNETIC FIELDS SETUP

Model : F208B



Model : F108X





VOLTAGE DIPS & VOLTAGE INTERRUPTIONS SETUP

