OPERATION AND TECHNICAL MANUAL
MODEL 884
FM MODULATION AND STEREO MONITOR



P/N 5004-0884

May 25, 1988

Revision A

Equipment Serial No. _____

Shipping Date _____

OPERATION AND TECHNICAL MANUAL
MODEL 884
FM MODULATION AND STEREO MONITOR

TFT, Inc.
3090 Oakmead Village Drive
Santa Clara, CA 95052
TEL (408) 727-7272
TWX 910-338-0584
FAX (408) 727-5942

TFT OPERATION MANUAL ADDENDUM

MODEL 884 MANUAL REVISION LEVEL A EFFECTIVITY S/N _____

IMPORTANT MANUAL CHANGES

The following drawings and Parts List replace the previous RF Preselector drawings and Parts List:

Drawing Description	Reason for change/Changes	Drawing No.
1. RF Preselector Bd.	New generation RF Preselector Board has been installed in the 884 unit.	6601-3713, Rev. A
2. RF Preselector Bd.	New generation RF Preselector Board has been installed in the 884 unit.	6608-3713, Rev. A
3. RF Preselector Parts List	To reflect the new RF Preselector Board, revised Parts List.	6608-3713, Rev. A Parts List
5. FM Demodulator Bd.	To accomodate the new RF Preselector Board, changed R181 from 100Ω to 10Ω.	6601-3645, Rev B
6. FM Demodulator Bd.	To accomodate the new RF Preselector Board, changed R181 from 100Ω to 10Ω.	6608-3645, Rev B
7. FM Demodulator Parts List	Revised Parts List to reflect the change in the value of R181.	6608-3645, Rev. B Parts List
8. 884 Block Diagram	Revised to reflect new RF Preselector Board.	6600-2597
9. Interconnect Diagram	Revised to reflect new RF Preselector Board	6600-2527, Rev. B
10. Revised title page for Revision B.		
11. Revised Table of Contents to reflect new RF Preselector Board and to correct error in drawing numbers for the FM Demodulator Board.		
12. Revised text in Paragraph 4.2 to reflect the new RF Preselector Board.		

Date 2-22-89

Form No. 5300-0268

P/N 5004-0884

February 21, 1989

Revision B

Equipment Serial No. _____

Shipping Date _____

OPERATION AND TECHNICAL MANUAL
MODEL 884
FM MODULATION AND STEREO MONITOR

TFT, Inc.
3090 Oakmead Village Drive
Santa Clara, CA 95052-8088
TEL (408) 727-7272
TWX 910-338-0584
FAX (408) 727-5942

3.4.8	FM Noise	3-7
3.4.9	Distortion	3-8
3.4.10	Pilot Frequency	3-8
3.4.11	Peak Modulation	3-8
3.4.12	Synchronous and Asynchronous AM Noise	3-9

Figure 3-1	Model 884 Front and Rear Panel Illustration	6600-2523
------------	---------------------------------------------	-----------

SECTION 4 THEORY OF OPERATION

4.1	General Discussion (Figure 6-1).....	4-1
4.2	RF Preselector A1 (Figure 6-3).....	4-1
4.3	FM Demodulator A3 (Figure 6-5)	4-2
4.4	FM Stereo A4 (Figure 6-7).....	4-3
4.5	Display Driver A6 (Figure 6-10)	4-4

SECTION 5 MAINTENANCE

5.1	Calibration	5-1
5.1.1	Meter Calibration	5-1
5.1.2	Peak Modulation Calibration	5-1
5.1.3	Stereo Separation Adjustment	5-2

SECTION 6A DIAGRAMS AND SCHEMATICS

Figure No.	Title	Drawing No.
6-1	Model 884 Block Diagram	6600-2597
6-2	Model 884 Interconnect Diagram	6600-2297
6-3	RF Preselector A1, Schematic	6601-3713
6-4	RF Preselector A1, Assembly	6608-3713
6-5	FM Demodulator A3, Schematic	6601-3645
6-6	FM Demodulator A3, Assembly	6608-3645
6-7	FM Stereo A4, Schematic	6601-3595
6-8	FM Stereo A4, Assembly	6608-3595
6-9	Display Driver A6, Schematic	6601-3410
6-10	Display Driver A6, Assembly	6608-3410

SECTION 4

THEORY OF OPERATION

4.1 General Discussion (Figure 6-1)

The Model 884 FM Modulation and Stereo Monitor contains a low level RF preselector, FM monitor, stereo baseband monitor, and a peak detector. Four major circuit boards perform these functions: RF Preselector A1, FM Demodulator A3, FM Stereo A4, and Display Driver A6. The block diagram, Figure 6-1, is located in Section 6 of this manual.

RF input from either transmitter or antenna enters the 884 rear panel and is routed to RF Preselector A1. Here the signal is padded through the attenuated circuit to a balanced mixer. The 900 kHz IF signal is sent to a low pass filter. This IF is then routed to the Demodulator Board A3.

FM Demodulator A3 receives the 900 kHz IF, demodulates the signal, and delivers a pulsed output that is filtered and amplified. The resulting signal is filtered and routed to the FM Stereo Board. On A4 the composite signal is filtered and returned to A3 and to the front panel monitors and test outputs. Separation adjust is also performed on A4.

Positive and negative modulation are used to drive the front panel PEAK flashers on A6, the Display Driver. Each modulation peak is compared in a peak detector to a voltage obtained from a constant current source by means of resistances selected by pushbutton switches on the PEAK MODULATION flashers. The pulse outputs produced by the peak detectors when modulation exceeds user preset values are applied to the front panel LED flashers, which light for approximately 2 seconds.

4.2 RF Preselector A1 (Figure 6-3)

The RF input to the monitor comes from the sampling point of the transmitter as a high level signal or from an antenna. The high input level enters the 884 through the rear panel RF INPUT HI LEVEL (50 ohm) connector J7. The signal is fed through the adjustable attenuator HI LEVEL RF INPUT SET R2 on the rear panel. This high level input signal is adjusted for a constant level and goes to the AM NOISE detector, which is routed to the front panel TOTAL MODULATION/TEST meter. The high level also lights the rear panel HI LEVEL RF INPUT SET LED (21) when the RF level adjust is correct. The RF signal goes to the ANTENNA INPUT jack (24).

When an antenna signal is fed to the ANTENNA INPUT, J5, it is routed to Z1 and mixed with the frequency synthesizer L.O. (local oscillator) and becomes a 10.7 MHz IF. This IF is fed to linear phase filter FL1 and then the IF amplifier U1. At U1, the level detectors detect the antenna level as the dc component. When detected, the antenna level is fed to U5, the mute detector. The factory sets the mute level for 40 μ V RF input. When the mute level is less than the factory-set level, U5 shuts off the demodulator. This level also goes to the rear panel terminal strip, TB 2.

The IF from U1 is also fed to T1, the IF transformer, and then to U17, the balanced mixer. The 10.7 MHz signal mixes with the second L.O., 10 MHz, from the timebase crystal oscillator. The mixed signal goes to the low pass filter which looks for the 700 kHz second IF. This 700 kHz is routed to the Q7 and Q8 switch and fed to A3, the FM Demodulator Board.

The 10 MHz timebase is crystal-controlled oscillator Y1 and its associated components. It is the reference for the PLL frequency synthesizer and is also the second L.O.

4.3 FM Demodulator A3 (Figure 6-5)

The 900 kHz IF signal which is applied to the FM Demodulator Board A3 through a relay to a pulse counting FM demodulator circuit. The limiting amplifier, U1, is driven into saturation to provide limiting. U2 is a one-shot multivibrator acting as a pulse averaging discriminator. It delivers a pulsed output whose frequency is the same as the IF but with a fixed pulse width. The duty cycle in the output pulse train varies with the modulation and the audio is recovered by passing the discriminator output through a low pass filter. Transistors Q1 thru Q4 make up the clamping circuit.

The low pass filter consists of L2 and L3 and amplifier U7. This circuit provides a flat response to 100 kHz and linear phase in order to give good stereo measurements. The frequency response rolls off after 100 kHz to eliminate any residual 900 kHz. Amplifier U10 raises the audio level to 1 Vrms.

The monitor calibration circuit consists of U3 thru U6. The 358 kHz output of the timebase is divided down to 4.48 kHz, which is then used to gate the 200 kHz on and off at a 4.48 kHz rate. This simulates a 100% modulated input. When the front panel METER CAL switch is depressed, this calibration signal is fed into limiting amplifier U1 and discriminator U2 in place of the 900 kHz IF. After passing through a 7.5 kHz calibration low pass filter, it is amplified by U8, which is adjusted by CAL LEVEL ADJUST R29 to give a 100% reading on the TOTAL MODULATION/TEST meter. The signal can also be used to check meter and flasher calibration. The circuit is very stable and can be used to correct drifts in the one-shot discriminator U2 and the meter amplifiers.

CKT. REF.	DESCRIPTION	QTY.	TFT STOCK NO.
C004	CAP CER 0.1MF CK05BX K	1	1015-0001
C005	CAP CER 0.1MF CK05BX K	1	1015-0001
C006	CAP CER 0.001MF CK05	1	1015-0010
C007	CAP CER .01MF CK05BX K	1	1015-0002
C011	CAP CER 0.1MF CK05BX K	1	1015-0001
C012	CAP CER .01MF CK05BX K	1	1015-0002
C013	CAP CER .01MF CK05BX K	1	1015-0002
C014	CAP CER .01MF CK05BX K	1	1015-0002
C021	CAP MINI CER 68PF NPO 63V	1	1017-0680
C024	CAP CER .01MF CK05BX K	1	1015-0002
C025	CAP MINI CER 120PF NPO 63V	1	1017-1200
C027	CAP DIP TANT 10MF/25V	1	1008-0100
C030	CAP ELEC 10MFD 25V NP V MT	1	1010-0013
C035	CAP VAR 5-55PF	1	1012-0555
C036	CAP CER 0.1MF CK05BX K	1	1015-0001
C042	CAP CER .01MF CK05BX K	1	1015-0002
C043	CAP CER .01MF CK05BX K	1	1015-0002
C044	CAP CER 0.1MF CK05BX K	1	1015-0001
C045	CAP CER 0.1MF CK05BX K	1	1015-0001
C046	CAP CER .0012MF CK05	1	1015-0040
C047	CAP MICA 56 PF	1	1001-0560
C048	CAP CER 0.1MF CK05BX K	1	1015-0001
C049	CAP CER 0.1MF CK05BX K	1	1015-0001
C050	CAP CER .01MF CK05BX K	1	1015-0002
C051	CAP CER 0.001MF CK05	1	1015-0010
C052	CAP CER .01MF CK05BX K	1	1015-0002
C053	CAP MINI CER 33PF NPO RECT	1	1017-0330
C054	CAP MICA 200 PF	1	1001-0201
C055	CAP VAR 5-55PF	1	1012-0555
C056	CAP CER 0.1MF CK05BX K	1	1015-0001
C057	CAP MICA 1000PF 500V	1	1001-0102
C058	CAP MICA 470PF 500V	1	1001-0471
C059	CAP CER 0.1MF CK05BX K	1	1015-0001
C060	CAP CER 0.001MF CK05	1	1015-0010
C061	CAP CER 0.1MF CK05BX K	1	1015-0001
C062	CAP TAN 1MFD 35V	1	1008-0011
C063	CAP MINI CER 33PF NPO RECT	1	1017-0330
C064	CAP CER 0.1MF CK05BX K	1	1015-0001
C065	CAP CER 0.1MF CK05BX K	1	1015-0001
C066	CAP CER .01MF CK05BX K	1	1015-0002
C067	CAP CER 0.1MF CK05BX K	1	1015-0001
C068	CAP CER 470 PF CK05B	1	1015-0470
C070	CAP CER 0.001MF CK05	1	1015-0010
C071	CAP CER 0.001MF CK05	1	1015-0010
C072	CAP TAN 1MFD 35V	1	1008-0011
C073	CAP CER 0.1MF CK05BX K	1	1015-0001

Model 884 FM Modulation and Stereo Monitor PCB Assy. 6608-3713
 RF Preselector Board Rev. A

CKT. REF.	DESCRIPTION	QTY.	TFT STOCK NO.
C074	CAP CER 820PF CK0 5BX	1	1015-0820
C075	CAP CER 0.1MF CK05BX K	1	1015-0001
C077	CAP DIP TANT 10MF/25V	1	1008-0100
C078	CAP CER 0.1MF CK05BX K	1	1015-0001
C081	CAP CER 0.1MF CK05BX K	1	1015-0001
C082	CAP CER 0.1MF CK05BX K	1	1015-0001
C086	CAP CER 0.1MF CK05BX K	1	1015-0001
C087	CAP CER 0.1MF CK05BX K	1	1015-0001
C088	CAP CER 0.1MF CK05BX K	1	1015-0001
C090	CAP MINI CER 120PF NPO 63V	1	1015-0001
C091	CAP CER 0.1MF CK05BX K	1	1017-1200
C092	CAP CER 0.1MF CK05BX K	1	1015-0001
C093	CAP CER 0.1MF CK05BX K	1	1015-0001
C094	CAP CER 0.1MF CK05BX K	1	1015-0001
C096	CAP CER 0.1MF CK05BX K	1	1015-0001
C097	CAP ELECT 1.0MFD 50V RADIAL	1	1015-0001
C098	CAP ELECT 1.0MFD 50V RADIAL	1	1010-0009
C099	CAP ELEC 10MFD 25V NP V MT	1	1010-0009
C100	CAP CER 0.1MF CK05BX K	1	1010-0013
C101	CAP CER 0.1MF CK05BX K	1	1015-0001
C102	CAP CER .01MF CK05BX K	1	1015-0001
CR01	DIO 1N3064	1	1015-0002
CR02	DIODE VERICAP BB505G 2-16PF	1	1281-3064
CR03	DIO HP5082 HOT CARRIER	1	1290-0105
CR06	DIO 1N3064	1	1282-2800
FL01	FILTER 10.7MHZ IF TUNER	1	1281-3064
HS01	HEAT SINK WAVESOLDERABLE	1	1052-0110
HS02	HEAT SINK WAVESOLDERABLE	1	2010-0637
J003	CONN. 12 PIN HEADER MALE .100 CTR	1	2010-0637
J004	PLUG LOCK .10 CTR 8 PIN	1	2250-5842
J007	CONN 3PIN HEADER MALE .100 CTR	1	2250-9508
J009	CONN. 12 PIN HEADER MALE .100 CTR	1	2250-5830
J010	CONN. 12 PIN HEADER MALE .100 CTR	1	2250-5842
J011	CONN W/O LOCK .100 CNTR 3 PIN	1	2250-5842
L002	INDUCTOR 100UH	1	2250-5803
L003	INDUCTOR 100UH	1	1531-0101
L004	CHOKE RF 2.2UH	1	1531-0101
L005	CHOKE RF 2.2UH	1	1531-0021
L010	CHOKE 47UH	1	1531-0021
LED1	LED GREEN LEDCO 8"	1	1531-0470
LED6	LED HP 5082-4487 CLEAR	1	1285-4951
PCB1	PCB RF PRESELECTOR BD	1	1285-4487
Q001	TRANS 2N3563	1	1600-3672
Q006	TRANS 2N3563	1	1271-3563
Q007	TRANS 2N3563	1	1271-3563
Q008	TRANS 2N3563	1	1271-3563

Model 884 FM Modulation and Stereo Monitor
RF Preselector Board

PCB Assy. 6/
Rev. A

CKT. REF.	DESCRIPTION	QTY.	TFT STOCK NO.
Q009	TRANS 2N3563	1	1271-3563
Q011	TRANS PN2222A NPN	1	1271-2223
R002	RES CAR FILM 1/4W 5% 10K	1	1065-1002
R005	RES CAR FILM 4.7K 1/4W 5%	1	1065-4701
R006	RES CAR FILM 1/4W 5% 150 OHM	1	1065-0150
R007	RES CAR FILM 1/4W 5% 10K	1	1065-1002
R008	RES CAR FILM 4.7K 1/4W 5%	1	1065-4701
R011	RES CAR FILM 1/4W 5% 2.2K	1	1065-2201
R012	RES CAR FILM 1/4W 5% 470 OHM	1	1065-0470
R013	RES CAR FILM 1/4W 5% 470 OHM	1	1065-0470
R014	RES CAR FILM 1/4W 5% 10K	1	1065-1002
R015	RES CAR COMP 1/4W 5% 330	1	1065-0330
R020	RES CAR COMP 1/4W 5% 680	1	1065-0680
R022	RES CAR FILM 1/4W 5% 1K	1	1065-1001
R026	RES CAR FILM 1/4W 5% 10 OHM	1	1065-0010
R031	RES MT FLM 1/8W 1% 1K	1	1061-1001
R035	RES CAR FILM 4.7K 1/4W 5%	1	1065-4701
R036	RES CAR FILM 1/4W 5% 15K	1	1065-1502
R042	RES CAR COMP 1/4W 5% 100K	1	1065-1003
R043	RES VAR PC MT 5K 1T	1	1072-5001
R044	RES VAR PC MT 5K 1T	1	1072-5001
R045	RES CAR FILM 1/4W 5% 390 OHM	1	1065-0390
R046	RES CAR COMP 1/4W 5% 22K	1	1065-2202
R051	RES CAR FILM 1/4W 5% 47 OHM	1	1065-0047
R052	RES CAR FILM 1/4W 5% 47K	1	1065-4702
R053	RES CAR FILM 1/4W 5% 10K	1	1065-1002
R054	RES CAR COMP 1/4W 5% 100K	1	1065-1003
R055	RES CAR FILM 1/4W 5% 15K	1	1065-1502
R056	RES CAR FILM 1/4W 5% 10K	1	1065-1002
R057	RES CAR FILM 4.7K 1/4W 5%	1	1065-4701
R058	RES CAR FILM 1/4W 5% 2.2K	1	1065-2201
R059	RES CAR COMP 1/4W 5% 100K	1	1065-1003
R060	RES CAR COMP 1/4W 5% 100	1	1065-0100
R061	RES CAR FILM 1/4W 5% 10K	1	1065-1002
R062	RES CAR FILM 4.7K 1/4W 5%	1	1065-4701
R063	RES CAR COMP 1/4W 5% 270	1	1065-0270
R064	RES CAR COMP 1/4W 5% 6.8K	1	1065-6801
R065	RES CAR COMP 1/4W 5% 1.5K	1	1065-1501
R066	RES CAR 1/4W 5% 200K	1	1065-2003
R067	RES CAR FILM 1/4W 5% 27K	1	1065-2702
R068	RES CAR COMP 1/4W 5% 1.2K	1	1065-1201
R069	RES CAR COMP 1/4W 5% 240	1	1065-0240
R070	RES CAR COMP 1/4W 5% 100	1	1065-0100
R071	RES CAR FILM 1/4W 5% 1K	1	1065-1001
R072	RES CAR FILM 1/4W 5% 10 OHM	1	1065-0010
R073	RES CAR FILM 1/4W 5% 1K	1	1065-1001

Model 884 FM Modulation and Stereo Monitor
RF Preselector Board

PCB Assy. 6608-3713
Rev. A

CKT. REF.	DESCRIPTION	QTY.	TFT STOCK NO.
R074	RES CAR COMP 1/4W 5% 6.8K	1	1065-6801
R075	RES CAR FILM 1/4W 5% 470 OHM	1	1065-0470
R077	RES CAR FILM 1/4W 5% 560	1	1065-0560
R078	RES CAR FILM 1/4W 5% 820 OHM	1	1065-0820
R079	RES CAR FILM 1/4W 5% 10K	1	1065-1002
R082	RES MT FLM 1/8W 1% 10K	1	1061-1002
R083	RES MT FLM 1/8W 1% 100.	1	1061-0100
R084	RES MT FLM 1/8W 1% 1.05K	1	1061-1051
R085	RES CAR FILM 1/4W 5% 10K	1	1065-1002
R086	RES CAR FILM 1/4W 5% 1K	1	1065-1001
R087	RES CAR FILM 1/4W 5% 1K	1	1065-1001
R088	RES CAR FILM 1/4W 5% 10K	1	1065-1002
R089	RES CAR COMP 1/4W 5% 100	1	1065-0100
R092	RES CAR FILM 1/4W 5% 1K	1	1065-1001
R093	RES CAR FILM 1/4W 5% 1K	1	1065-1001
R094	RES CAR FILM 1/4W 5% 10K	1	1065-1002
R095	RES CAR COMP 1/4W 5% 100	1	1065-0100
R097	RES VAR PC MT 5K 1T	1	1072-5001
R098	RES CAR FILM 1/4W 5% 10K	1	1065-1002
R099	RES CAR COMP 1/4W 5% 100	1	1065-0100
R100	RES CAR COMP 1/4W 5% 100	1	1065-0100
R106	RES CAR COMP 1/4W 5% 100	1	1065-0100
R108	RES CAR FILM 4.7K 1/4W 5%	1	1065-4701
R109	RES CAR FILM 4.7K 1/4W 5%	1	1065-4701
R110	RES CAR FILM 4.7K 1/4W 5%	1	1065-4701
R117	RES CAR FILM 1/4W 5% .1K	1	1065-1001
R118	RES CAR COMP 1/4W 5% 100	1	1065-0100
R119	RES CAR FILM 1/4W 5% 1K	1	1065-1001
R120	RES CAR COMP 1/4W 5% 6.8K	1	1065-6801
R121	RES CAR COMP 1/4W 5% 6.8K	1	1065-6801
R122	RES CAR COMP 1/4W 5% 6.8K	1	1065-6801
R123	RES CAR COMP 1/4W 5% 6.8K	1	1065-6801
R124	RES CAR FILM 1/4W 5% 15K	1	1065-1502
R125	RES CAR COMP 2W 5% 10	1	1068-0014
R126	RES CAR COMP 1/4W 5% 100K	1	1065-1003
RP01	RES NETWORK 47K 6 PIN	1	1073-4713
RP02	RES NETWORK 47K 6 PIN	1	1073-4713
RP03	RES NETWORK 47K 6 PIN	1	1073-4713
RP04	RES NETWORK 47K 6 PIN	1	1073-4713
T001	10.7MHZ IF XFMR 1:1	1	1501-0657
U001	I/C CA3189E	1	1100-3189
U002	I/C 74HC390N DUAL 4-STAGE	1	1104-0390
U005	IC TL084CN OP AMP JFET INPUT	1	1100-6084
U006	IC TL084CN OP AMP JFET INPUT	1	1100-6084
U008	I/C MC145152 FREQ SYNTHESIZER	1	1102-4552
U009	I/C NMC27C32	1	1102-2732

Model 884 FM Modulation and Stereo Monitor
RF Preselector Board

PCB Assy. 6608-3713
Rev. A

CKT. REF.	DESCRIPTION	QTY.	TFT STOCK NO.
U010	I/C NMC27C32	1	1102-2732
U011	I/C 74LS158 QD 2/1 LINE MUX	1	1101-0158
U012	I/C 74LS158 QD 2/1 LINE MUX	1	1101-0158
U013	I/C 74LS158 QD 2/1 LINE MUX	1	1101-0158
U014	I/C VOLT REG +8V LM340-8.0	1	1100-4080
U015	I/C MC1458CG	1	1100-1458
U016	I/C MC1458CG	1	1100-1458
U017	IC NE602 MIXER OSC	1	1100-0602
U018	I/C MC12016 225MHZ DIVIDE 40/41	1	1100-1202
U019	I/C LM340T-12	1	1100-0340
U020	(USE 1100-7805) I/C LM342P-5.0	1	1100-4205
U021	I/C LF356N	1	1100-0356
XU01	SOCKET, I/C 16 PIN	1	2250-1016
XU02	SOCKET, I/C 16 PIN	1	2250-1016
XU05	SOCKET, I/C 16 PIN	1	2250-1016
XU06	SOCKET, I/C 16 PIN	1	2250-1016
XU08	SOCKET I/C DIP-28 PIN	1	2250-1028
XU09	SOCKET I/C 24 PIN	1	2250-1024
XU10	SOCKET I/C 24 PIN	1	2250-1024
XU11	SOCKET, I/C 16 PIN	1	2250-1016
XU12	SOCKET, I/C 16 PIN	1	2250-1016
XU13	SOCKET, I/C 16 PIN	1	2250-1016
XU15	SOCKET, I/C 8 PIN	1	2250-1008
XU16	SOCKET, I/C 8 PIN	1	2250-1008
XU18	SOCKET, I/C 8 PIN	1	2250-1008
XU21	SOCKET, I/C 8 PIN	1	2250-1008
Y001	XTAL 10 MHZ 844A	1	2400-1071
Z001	FM TUNER CET-502CNF (V)	1	4500-1813

CKT. REF.	DESCRIPTION	QTY.	TFT STOCK NO.
C001	CAP CER DISC 1MFD	1	1005-0001
C002	CAP CER DISC 1MFD	1	1005-0001
C003	CAP CER DISC 1MFD	1	1005-0001
C004	CAP CER DISC 1MFD	1	1005-0001
C005	CAP MICA 56 PF	1	1005-0001
C006	CAP MICA 10 PF	1	1001-0560
C007	CAP MICA 10 PF	1	1001-0100
C008	CAP ELEC 1000MF 16V VERT MT	1	1001-0100
C009	CAP CER 0.1MF CK05BX K	1	1010-0012
C010	CAP MICA 10 PF	1	1015-0001
C011	CAP MICA 10 PF	1	1001-0100
C012	CAP CER .0039MF CK05 BX 392K	1	1001-0100
C013	CAP MICA 240 PF	1	1001-0100
C014	CAP CER .0082MF CK05BX	1	1015-0039
C015	CAP ELECT 10MF 10V RADIAL	1	1001-0241
C016	CAP CER 0.1MF CK05BX K	1	1015-0082
C017	CAP CER 0.1MF CK05BX K	1	1010-0011
C018	CAP MET POLY .01UF +21/2	1	1015-0001
C019	CAP MICA 91 PF 500V	1	1015-0001
C020	CAP CER 0.1MF CK05BX K	1	1006-0002
C021	CAP CER 0.1MF CK05BX K	1	1001-0910
C022	CAP CER 0.1MF CK05BX K	1	1015-0001
C023	CAP CER 0.1MF CK05BX K	1	1015-0001
C024	CAP MICA 1000PF 500V	1	1015-0001
C025	CAP MICA 270 PF	1	1015-0001
C026	CAP MICA 1700 PF	1	1001-0102
C027	CAP MICA 200 PF	1	1001-0102
C028	CAP MICA 1000PF 500V	1	1001-0271
C029	CAP MICA 270 PF	1	1001-0172
C030	CAP ELEC 470MF 25V VERT MNT	1	1001-0201
C031	CAP CER DISC 1MFD	1	1001-0102
C032	CAP CER DISC 1MFD	1	1001-0271
C033	CAP MICA 18 PF	1	1010-0045
C034	CAP MICA 270 PF	1	1005-0001
C035	CAP MICA 33PF 500V	1	1005-0001
C036	CAP MICA 470PF 500V	1	1001-0180
C037	CAP MICA 470PF 500V	1	1001-0271
C038	CAP MICA 240 PF	1	1001-0271
C039	CAP MICA 5.0PF 500V	1	1001-0330
C040	CAP MICA 22 PF	1	1001-0471
C041	CAP MICA 100 PF	1	1001-0471
C042	CAP MICA 75 PF	1	1001-0241
C043	CAP CER DISC 1MFD	1	1001-0050
C044	CAP CER DISC 1MFD	1	1001-0220
C045	CAP CER 0.1MF CK05BX K	1	1001-0101
C046	CAP MICA 51 PF	1	1001-0750
		1	1005-0001
		1	1005-0001
		1	1015-0001
		1	1001-0510

CKT. REF.	DESCRIPTION	QTY.	TFT STOCK NO.
C047	CAP MICA 1000PF 500V	1	1001-0102
C048	CAP MICA 470PF 500V	1	1001-0471
C049	CAP CER 0.1MF CK05BX K	1	1015-0001
C057	CAP CER DISC 1MFD	1	1005-0001
C058	CAP CER DISC 1MFD	1	1005-0001
C059	CAP TAN 4.7MFD 35V 10%	1	1008-0047
C060	CAP TAN 10MFD 20V 10%	1	1008-0101
C061	CAP CER 0.1MF CK05BX K	1	1015-0001
C062	CAP CER 0.1MF CK05BX K	1	1015-0001
C063	CAP CER DISC 1MFD	1	1005-0001
C064	CAP CER DISC 1MFD	1	1005-0001
C065	CAP CER DISC 1MFD	1	1005-0001
C066	CAP CER DISC 1MFD	1	1005-0001
C067	CAP CER .068MF CK05BX K	1	1015-0013
C068	CAP ELECT 10 MFD 25V VERT MT	1	1010-0099
C069	CAP CER DISC 1MFD	1	1005-0001
C070	CAP ELEC 470MF 25V VERT MNT	1	1010-0045
C071	CAP CER .22MF CK06BX K	1	1015-0003
C072	CAP CER 0.1MF CK05BX K	1	1015-0001
C073	CAP CER 0.1MF CK05BX K	1	1015-0001
C074	CAP CER DISC 1MFD	1	1005-0001
C075	CAP CER DISC 1MFD	1	1005-0001
C076	CAP CER DISC 1MFD	1	1005-0001
C077	CAP CER DISC 1MFD	1	1005-0001
C079	CAP CER DISC 1MFD	1	1005-0001
C080	CAP CER DISC 1MFD	1	1005-0001
C081	CAP MET POLY .01UF +21/2	1	1006-0002
C082	CAP CER DISC 1MFD	1	1005-0001
C083	CAP CER DISC 1MFD	1	1005-0001
C084	CAP MET POLY .01UF +21/2	1	1006-0002
C085	CAP CER .22MF CK06BX K	1	1015-0003
C086	CAP CER DISC 1MFD	1	1005-0001
C087	CAP CER DISC 1MFD	1	1005-0001
C088	CAP CER .22MF CK06BX K	1	1015-0003
C089	CAP CER 0.1MF CK05BX K	1	1015-0001
C090	CAP CER 0.1MF CK05BX K	1	1015-0001
C091	CAP TAN 10MFD 20V 10%	1	1008-0101
C092	CAP TAN 4.7MFD 35V 10%	1	1008-0047
C093	CAP ELECT 8000MFD 25V	1	1010-8000
C094	CAP CER 0.1MF CK05BX K	1	1015-0001
C095	CAP ELECT 4700MFD 35V	1	1010-0472
C096	CAP CER 0.1MF CK05BX K	1	1015-0001
C099	CAP ELECT VT MT 100UF (NO SUB.)	1	1010-0110
C100	CAP ELECT VT MT 100UF (NO SUB.)	1	1010-0110
C101	CAP ELECT VT MT 100UF (NO SUB.)	1	1010-0110
C102	CAP ELECT 25MFD 6V	1	1010-0250

CKT. REF.	DESCRIPTION	QTY.	TFT STOCK NO.
C104	CAP ELECT 10 MFD 25V VERT MT	1	1010-0099
C105	CAP ELECT VT MT 100UF (NO SUB.)	1	1010-0110
C106	CAP CER 0.1MF CK05BX K	1	1015-0001
C107	CAP CER 0.1MF CK05BX K	1	1015-0001
C109	CAP MICA 27PF 500V	1	1001-0270
C110	CAP VAR 10-40PF	1	1012-1040
C112	CAP MICA 47 PF	1	1001-0470
CR01	DIO HP5082 HOT CARRIER	1	1282-2800
CR02	DIO HP5082 HOT CARRIER	1	1282-2800
CR03	DIO HP5082 HOT CARRIER	1	1282-2800
CR05	DIO HP5082 HOT CARRIER	1	1282-2800
CR06	DIO HP5082 HOT CARRIER	1	1282-2800
CR07	DIO HP5082 HOT CARRIER	1	1282-2800
CR08	DIO 1N3064	1	1281-3064
CR09	DIO HP5082 HOT CARRIER	1	1282-2800
CR10	MDA970A2 BRIDGE RECTIFIER	1	1284-9702
CR11	MDA970A2 BRIDGE RECTIFIER	1	1284-9702
CR12	DIO HP5082 HOT CARRIER	1	1282-2800
HS01	HEAT SINK EBS	1	2010-1401
INS1	INSULATOR MICA T0220 PKG	1	2140-0103
INS2	INSULATOR MICA T0220 PKG	1	2140-0103
J001	PLUG, LOCKING 2 PIN	1	2250-6002
J002	PLUG LOCK 8 PIN MOLEX	1	2250-6508
J003	PLUG LOCK MOLEX 7 PIN	1	2250-6507
J004	CONN 14 PIN MOLEX	1	2250-6014
J005	PLUG, 10 PIN	1	2250-6510
J006	PLUG LOCK 8 PIN MOLEX	1	2250-6508
J007	PLUG, 4 PIN	1	2250-6004
J008	CONN 12 PIN MOLEX	1	2250-6012
J009	PLUG LOCK MOLEX 6 PIN	1	2250-6506
J010	PLUG LOCK MOLEX 6 PIN	1	2250-6506
J011	PLUG LOCK MOLEX 6 PIN	1	2250-6506
J012	PLUG, LOCKING 3 PIN	1	2250-6003
J013	PLUG, LOCKING 3 PIN	1	2250-6003
J014	PLUG, LOCKING 3 PIN	1	2250-6003
J015	PLUG LOCK MOLEX 4 PIN	1	2250-6504
L001	CHOKE RF 2 1/2 TURNS	1	1530-0025
L002	M/L IND VAC 76T	1	1577-0920
L003	M/L IND VAC 76T	1	1577-0920
L004	CHOKE 560 UH	1	1530-0561
L005	CHOKE R F 470 UH	1	1530-0471
L006	CHOKE R F 27 UH	1	1530-0270
L007	CHOKE R F 470 UH	1	1530-0471
NU01	NUT 4-40 SELF LOCK W/NYLON INSERT	1	2111-0002
NU02	NUT 4-40 SELF LOCK W/NYLON INSERT	1	2111-0002
NYW1	NYLON WASHER PWR TRANSISTOR	1	2140-0137

CKT. REF.	DESCRIPTION	QTY.	TFT STOCK NO.
NYW2	NYLON WASHER PWR TRANSISTOR	1	2140-0137
PCB01	PCB A3 FM DEMODULATOR	1	1600-3405
Q001	TRANS 2N4275	1	1271-4275
Q002	TRANS 2N4121	1	1271-4121
Q003	TRANS 2N4275	1	1271-4275
Q004	TRANS 2N4275	1	1271-4275
Q005	TRANS 2N4121	1	1271-4121
Q006	TRANS 2N3563	1	1271-3563
Q007	TRANS 2N4275	1	1271-4275
Q008	TRANS 2N2222	1	1271-2222
Q009	TRANS 2N3643	1	1271-3643
Q010	TRANS 2N3643	1	1271-3643
R001	RES CAR FILM 1/4W 5% 1K	1	1065-1001
R002	RES CAR FILM 1/4W 5% 1K	1	1065-1001
R003	RES CAR FILM 1/4W 5% 150K	1	1065-1503
R004	RES CAR COMP 1/4W 5% 100	1	1065-0100
R005	RES CAR COMP 1/4W 5% 100	1	1065-0100
R006	RES MT FLM 1/8W 1% 10K	1	1061-1002
R007	RES CAR FILM 1/4W 5% 1M	2	1065-1004
R008	RES CAR FILM 4.7K 1/4W 5%	1	1065-4701
R009	RES CAR FILM 4.7K 1/4W 5%	1	1065-4701
R010	RES CAR FILM 4.7K 1/4W 5%	1	1065-4701
R011	RES CAR FILM 1/4W 5% 470 OHM	1	1065-0470
R012	RES CAR FILM 1/4W 5% 470 OHM	1	1065-0470
R013	RES CAR FILM 1/4W 5% 2.2K	1	1065-2201
R014	RES CAR FILM 1/4W 5% 2.2K	1	1065-2201
R015	RES M.F. 37.4 1% 1/8W	1	1061-0037
R016	RES M.F. 37.4 1% 1/8W	1	1061-0037
R017	RES MT FLM 1/8W 1% 750	1	1061-0750
R018	RES CAR COMP 1/4W 5% 3.3K	1	1065-3301
R019	RES CAR FILM 1/4W 5% 27K	1	1065-2702
R020	RES CAR FILM 1/4W 5% 27K	1	1065-2702
R021	RES CAR FILM 1/4W 5% 27K	1	1065-2702
R022	RES CAR COMP 1/4W 5% 100	1	1065-0100
R023	RES CAR COMP 1/4W 5% 100	1	1065-0100
R024	RES CAR FILM 1/4W 5% 27K	1	1065-2702
R025	RES CAR FILM 1/4W 5% 27K	1	1065-2702
R026	RES CAR COMP 1/4W 5% 100	1	1065-0100
R027	RES CAR COMP 1/4W 5% 100	1	1065-0100
R028	RES CAR FILM 1/4W 5% 56K	1	1065-5602
R029	RES VAR PC MT 20K 1T	1	1072-2002
R030	RES CAR FILM 1/4W 5% 39K	1	1065-3902
R031	RES CAR FILM 1/4W 5% 27K	1	1065-2702
R033	RES CAR COMP 1/4W 5% 100	1	1065-0100
R034	RES MT FLM 1/8W 1% 1K	1	1061-1001
R035	RES M.F. 2.43K 1% 1/8W	1	1061-2431

CKT. REF.	DESCRIPTION	QTY.	TFT STOCK NO.
R036	RES CAR COMP 1/4W 5% 7.5K	1	1065-7501
R037	RES CAR COMP 1/4W 5% 75K	1	1065-7502
R038	RES CAR COMP 1/4W 5% 100	1	1065-0100
R039	RES CAR COMP 1/4W 5% 100	1	1065-0100
R040	RES MT FLM 1/8W 1% 1.15K	1	1061-1151
R041	RES MT FLM 1/8W 1% 1K	1	1061-1001
R042	RES VAR PC MT 10K 10T	1	1069-1002
R043	RES CAR COMP 1/4W 5% 7.5K	1	1065-7501
R044	RES CAR COMP 1/4W 5% 75K	1	1065-7502
R045	RES CAR COMP 1/4W 5% 100	1	1065-0100
R046	RES CAR COMP 1/4W 5% 100	1	1065-0100
R047	RES CAR FILM 1/4W 5% 1K	1	1065-1001
R048	RES CAR FILM 1/4W 5% 10K	1	1065-1002
R049	RES CAR COMP 1/4W 5% 3.3K	1	1065-3301
R050	RES CAR COMP 1/4W 5% 1.5K	1	1065-1501
R051	RES CAR FILM 1/4W 5% 390 OHM	1	1065-0390
R052	RES CAR FILM 1/4W 5% 2.2K	1	1065-2201
R053	RES CAR FILM 1/4W 5% 1K	1	1065-1001
R054	RES CAR FILM 1/4W 5% 10K	1	1065-1002
R055	RES CAR FILM 1/4W 5% 470 OHM	1	1065-0470
R056	RES CAR FILM 4.7K 1/4W 5%	1	1065-4701
R071	RES CAR COMP 1/4W 5% 5.6K	1	1065-5601
R072	RES CAR FILM 1/4W 5% 10K	1	1065-1002
R073	RES CAR COMP 1/4W 5% 5.6K	1	1065-5601
R074	RES CAR FILM 1/4W 5% 2.2K	1	1065-2201
R075	RES CAR FILM 1/4W 5% 1K	1	1065-1001
R076	RES CAR COMP 1/4W 5% 100	1	1065-0100
R078	RES CAR COMP 1/4W 5% 100	1	1065-0100
R079	RES MT FLM 1/8W .1% 10K	1	1058-1002
R080	RES MT FLM 1/8W .1% 10K	1	1058-1002
R081	RES MT FLM 1/8W .1% 10K	1	1058-1002
R082	RES CAR COMP 1/4W 5% 100	1	1065-0100
R083	RES CAR COMP 1/4W 5% 100	1	1065-0100
R084	RES CAR FILM 1/4W 5% 10K	1	1065-1002
R085	RES MT FLM 1/8W 1% 7.5K	1	1061-7501
R086	RES CAR FILM 1/4W 5% 1K	1	1065-1001
R087	RES VAR PC MT 1K 1T	1	1072-1001
R088	RES CAR COMP 1/4W 5% 1.5K	1	1065-1501
R089	RES CAR COMP 1/4W 5% 6.8K	1	1065-6801
R090	RES CAR COMP 1/4W 5% 100	1	1065-0100
R091	RES CAR COMP 1/4W 5% 100	1	1065-0100
R092	RES CAR FILM 1/4W 5% 10K	1	1065-1002
R093	RES C.C. 62K 5% 1/4W	1	1065-6202
R094	RES CAR COMP 1/4W 5% 100	1	1065-0100
R095	RES CAR COMP 1/4W 5% 100	1	1065-0100
R096	RES CAR FILM 1/4W 5% 2.7K	1	1065-2701

CKT. REF.	DESCRIPTION	QTY.	TFT STOCK NO.
R097	RES CAR COMP 1/4W 5% 2K	1	1065-2001
R098	RES CAR FILM 1/4W 5% 56K	1	1065-5602
R099	RES CAR COMP 1/4W 5% 2K	1	1065-2001
R100	RES CAR COMP 1/4W 5% 100	1	1065-0100
R101	RES CAR COMP 1/4W 5% 100	1	1065-0100
R102	RES VAR PC MT 1K 1T	1	1072-1001
R103	RES CAR COMP 1/4W 5% 680K	1	1065-6803
R104	RES CAR COMP 1/4W 5% 330K	1	1065-3303
R105	RES MT FLM 1/8W 1% 1.37K	1	1061-1370
R106	RES MT FLM 1/8W 1% 432.	1	1061-0432
R107	RES MT FLM 1/8W 1% 137.	1	1061-0137
R108	RES MT FLM 1/8W 1% 43.2	1	1061-0043
R109	RES MT FLM 1/8W 1% 13.7	1	1061-0013
R110	RES MT FLM 1/8W 1% 12.7	1	1061-0012
R111	RES MT FLM 1/8W 1% 12.7	1	1061-0012
R112	RES CAR FILM 1/4W 5% 10K	1	1065-1002
R113	RES CAR FILM 4.7K 1/4W 5%	1	1065-4701
R114	RES CAR FILM 1/4W 5% 10K	1	1065-1002
R115	RES CAR COMP 1/4W 5% 12K	1	1065-1202
R116	RES CAR FILM 1/4W 5% 2.2K	1	1065-2201
R117	RES CAR COMP 1/4W 5% 100	1	1065-0100
R118	RES CAR COMP 1/4W 5% 100	1	1065-0100
R119	RES CAR FILM 1/4W 5% 13K	1	1065-1302
R120	RES CAR FILM 1/4W 5% 10K	1	1065-1002
R121	RES CAR COMP 1/4W 5% 100	1	1065-0100
R122	RES CAR COMP 1/4W 5% 100	1	1065-0100
R123	RES CAR COMP 1/4W 5% 7.5K	1	1065-7501
R124	RES CAR COMP 1/4W 5% 5.6K	1	1065-5601
R125	RES CAR COMP 1/4W 5% 100	1	1065-0100
R126	RES CAR COMP 1/4W 5% 100	1	1065-0100
R132	RES CAR COMP 1/4W 5% 100	1	1065-0100
R133	RES CAR COMP 1/4W 5% 100	1	1065-0100
R134	RES MT FLM 1/8W 1% 10K	1	1061-1002
R135	RES CAR COMP 1/4W 5% 100	1	1065-0100
R136	RES CAR COMP 1/4W 5% 100	1	1065-0100
R137	RES MT FLM 1/8W 1% 10K	1	1061-1002
R138	RES CAR FILM 1/4W 5% 10K	1	1065-1002
R139	RES VAR PC MT 10K 1T	1	1072-1002
R140	RES CAR FILM 1/4W 5% 10K	1	1065-1002
R141	RES CAR COMP 1/4W 5% 20K	1	1065-2002
R142	RES CAR COMP 1/4W 5% 100	1	1065-0100
R144	RES CAR COMP 1/4W 5% 680K	1	1065-6803
R145	RES CAR COMP 1/4W 5% 330K	1	1065-3303
R146	RES CAR FILM 1/4W 5% 1K	1	1065-1001
R147	RES CAR COMP 1/4W 5% 6.8K	1	1065-6801
R148	RES CAR COMP 1/4W 5% 100	1	1065-0100

CKT. REF.	DESCRIPTION	QTY.	TFT STOCK NO.
R149	RES CAR COMP 1/4W 5% 100	1	1065-0100
R150	RES CAR COMP 1/4W 5% 5.6K	1	1065-5601
R151	RES CAR FILM 1/4W 5% 10K	1	1065-1002
R152	RES CAR COMP 1/4W 5% 5.6K	1	1065-5601
R153	RES CAR COMP 1/4W 5% 100K	1	1065-1003
R154	RES CAR FILM 1/4W 5% 1K	1	1065-1001
R156	RES CAR COMP 1/4W 5% 100	1	1065-0100
R157	RES CAR COMP 1/4W 5% 100	1	1065-0100
R159	RES CAR FILM 1/4W 5% 10K	1	1065-1002
R160	RES CAR COMP 1/4W 5% 75K	1	1065-7502
R161	RES MT FLM 1/8W 1% 10K	1	1061-1002
R162	RES CAR COMP 1/4W 5% 7.5K	1	1065-7501
R163	RES CAR FILM 1/4W 5% 10K	1	1065-1002
R164	RES CAR FILM 4.7K 1/4W 5%	1	1065-4701
R165	RES MT FLM 1/8W 1% 10K	1	1061-1002
R166	RES CAR FILM 1/4W 5% 10K	1	1065-1002
R167	RES CAR FILM 4.7K 1/4W 5%	1	1065-4701
R168	RES CAR COMP 1/4W 5% 5.6K	1	1065-5601
R171	RES CAR COMP 1/4W 5% 100	1	1065-0100
R172	RES CAR COMP 1/4W 5% 100	1	1065-0100
R173	RES CAR COMP 1/4W 5% 100	1	1065-0100
R174	RES CAR COMP 1/4W 5% 100	1	1065-0100
R175	RES CAR COMP 1/4W 5% 100	1	1065-0100
R176	RES CAR COMP 1/4W 5% 100	1	1065-0100
R181	RES CAR FILM 1/4W 5% 10 OHM	1	1065-0010
R182	RES CAR COMP 1/4W 5% 100	1	1065-0100
R183	RES MT FLM 1/8W 1% 1MEG	1	1061-1004
S001	SW PB 10P "F" SER ORYLGN	1	1850-0101
SCR1	SCREW P.H. 4-40X1/2	1	2104-0040
SCR2	SCREW P.H. 4-40X1/2	1	2104-0040
SP001	SPACER 3/16"	1	2130-1875
SP002	SPACER 3/16"	1	2130-1875
SP01	SOLID PIN PLUG	1	2140-0071
SP02	SOLID PIN PLUG	1	2140-0071
SP03	SOLID PIN PLUG	1	2140-0071
SP04	SOLID PIN PLUG	1	2140-0071
TY01	TY-WRAP NYLON .14W x 5 5/8 LG	1	2140-0011
TY02	TY-WRAP NYLON .14W x 5 5/8 LG	1	2140-0011
TY03	TY-WRAP NYLON .14W x 5 5/8 LG	1	2140-0011
TY04	TY-WRAP NYLON .14W x 5 5/8 LG	1	2140-0011
TY05	TY-WRAP NYLON .14W x 5 5/8 LG	1	2140-0011
TY06	TY-WRAP NYLON .14W x 5 5/8 LG	1	2140-0011
TY07	TY-WRAP NYLON .14W x 5 5/8 LG	1	2140-0011
TY08	TY-WRAP NYLON .14W x 5 5/8 LG	1	2140-0011
U001	IC LM361J HI SPEED DIFF COMPARATOR	1	1100-0361
U002	I/C 74221 DUAL ONE SHOT	1	1100-7422

CKT. REF.	DESCRIPTION	QTY.	TFT STOCK NO.
U003	I/C CD4518BE	1	1102-4518
U004	I/C RCA CD4520BE 85T REG	1	1102-4520
U005	I/C RCA CD4001 QD 2-NOR	1	1102-4001
U006	I/C RCA CD4011 QD 2-NAND	1	1102-4011
U007	I/C LF356N	1	1100-0356
U008	I/C LF356N	1	1100-0356
U009	I/C LF356N	1	1100-0356
U010	I/C NE5534N	1	1100-0356
U011	I/C NE5534N	1	1100-5534
U012	SOCKET, I/C 8 PIN	1	1100-5534
U013	SOCKET, I/C 8 PIN	1	2250-1008
U014	I/C LF356N	1	2250-1008
U015	SOCKET, I/C 8 PIN	1	1100-0356
U016	I/C LF356N	1	2250-1008
U017	I/C LF356N	1	1100-0356
U018	I/C NE5534N	1	1100-0356
U019	I/C LF356N	1	1100-5534
U020	I/C LF356N	1	1100-0356
U021	SOCKET, I/C 8 PIN	1	1100-0356
U022	I/C LF356N	1	2250-1008
U023	I/C LF356N	1	1100-0356
U024	SOCKET, I/C 8 PIN	1	1100-0356
U025	I/C LM340T-12	1	2250-1008
U026	I/C MC7912	1	1100-0340
U027	SOCKET, I/C 8 PIN	1	1100-7912
U028	SOCKET, I/C 8 PIN	1	2250-1008
U029	I/C LM340T-05	1	2250-1008
U030	I/C VOLT REG +8V LM340-8.0	1	1100-7805
U031	I/C NE5534N	1	1100-4080
XU003	SOCKET, I/C 16 PIN	1	1100-5534
XU004	SOCKET, I/C 16 PIN	1	2250-1016
XU005	SOCKET I/C 14PIN	1	2250-1016
XU006	SOCKET I/C 14PIN	1	2250-1014
XU008	SOCKET, I/C 8 PIN	1	2250-1014
XU009	SOCKET, I/C 8 PIN	1	2250-1008
XU010	SOCKET, I/C 8 PIN	1	2250-1008
XU011	SOCKET, I/C 8 PIN	1	2250-1008
XU012	SOCKET, I/C 8 PIN	1	2250-1008
XU013	SOCKET, I/C 8 PIN	1	2250-1008
XU014	SOCKET, I/C 8 PIN	1	2250-1008
XU015	SOCKET, I/C 8 PIN	1	2250-1008
XU016	SOCKET, I/C 8 PIN	1	2250-1008
XU017	SOCKET, I/C 8 PIN	1	2250-1008
XU018	SOCKET, I/C 8 PIN	1	2250-1008
XU019	SOCKET, I/C 8 PIN	1	2250-1008
XU020	SOCKET, I/C 8 PIN	1	2250-1008

CKT. REF.	DESCRIPTION	QTY.	TFT STOCK NO.
XU021	SOCKET, I/C 8 PIN	1	2250-1008
XU022	SOCKET, I/C 8 PIN	1	2250-1008
XU023	SOCKET, I/C 8 PIN	1	2250-1008
XU024	SOCKET, I/C 8 PIN	1	2250-1008
XU027	SOCKET, I/C 8 PIN	1	2250-1008
XU028	SOCKET, I/C 8 PIN	1	2250-1008
XU031	SOCKET, I/C 8 PIN	1	2250-1008
Y001	XTAL 3.579 MHZ (850)	1	2400-0360

Table of Contents

Model 884 FM Modulation and Stereo Monitor

		Page
SECTION 1	GENERAL INFORMATION	
1.1	General Description	1-1
1.2	Specifications	1-2
1.3	Model 845 FM SCA Monitor	1-5
1.4	Warranty	1-5
1.5	Claim for Damage in Shipment	1-6
SECTION 2	INSTALLATION	
2.1	Unpacking and Inspection	2-1
2.2	Power Requirements	2-1
2.3	Model 884 Installation	2-1
2.4	Model 845 SCA Monitor Installation	2-2
SECTION 3	OPERATION	
3.1	General Discussion	3-1
3.2	Turn-on and Warm-up	3-1
3.3	Controls, Connectors, and Indicators	3-2
3.4	Measurements	3-5
	3.4.1 Main Channel Modulation (L + R)	3-5
	3.4.2 Stereo Subchannel Modulation	3-5
	3.4.3 Pilot Carrier Modulation	3-5
	3.4.4 38 kHz Subcarrier Suppression	3-5
	3.4.5 Stereo Separation	3-6
	3.4.5.1 Left Channel Modulated Signal	3-6
	3.4.5.2 Right Channel Modulated Signal	3-6
	3.4.6 Main Channel to Subchannel Crosstalk	3-7
	3.4.7 Subchannel to Main Channel Crosstalk	3-7
	3.4.8 FM Noise	3-7

3.4.9	Distortion	3-8
3.4.10	Pilot Frequency	3-8
3.4.11	Peak Modulation.....	3-8
3.4.12	Synchronous and Asynchronous AM Noise	3-9

Figure 3-1	Model 884 Front and Rear Panel Illustration	6600-2523
------------	---------------------------------------------	-----------

SECTION 4 THEORY OF OPERATION

4.1	General Discussion (Figure 6-1).....	4-1
4.2	RF Preselector A1 (Figure 6-3).....	4-1
4.3	FM Demodulator A3 (Figure 6-5)	4-2
4.4	FM Stereo A4 (Figure 6-7).....	4-3
4.5	Display Driver A6 (Figure 6-10)	4-4

SECTION 5 MAINTENANCE

5.1	Calibration	5-1
5.1.1	Meter Calibration	5-1
5.1.2	Peak Modulation Calibration	5-1
5.1.3	Stereo Separation Adjustment	5-2

SECTION 6A DIAGRAMS AND SCHEMATICS

Figure No.	Title	Drawing No.
6-1	Model 884 Block Diagram	6600-2526
6-2	Model 884 Interconnect Diagram	6600-2297
6-3	RF Preselector A1, Schematic	6601-3403
6-4	RF Preselector A1, Assembly	6608-3403
6-5	FM Demodulator A3, Schematic	6601-3405
6-6	FM Demodulator A3, Assembly	6608-3405
6-7	FM Stereo A4, Schematic	6601-3595
6-8	FM Stereo A4, Assembly	6608-3595
6-9	Display Driver A6, Schematic	6601-3410
6-10	Display Driver A6, Assembly	6608-3410

SECTION 1

GENERAL INFORMATION

1.1 General Description

The TFT Model 884 FM Stereo Modulation Monitor is a high quality, compact, and comprehensive monitor used to maintain desired modulation levels and FM broadcast quality standards. Contained in one 7-inch, rack-mounted package is a single-channel, low level RF preselector, an FM monitor, a stereo baseband monitor, and peak detectors.

The user can operate the Model 884 at the transmitter site, off-the-air at the studio, or can monitor composite signals from a stereo generator or composite STL when checking only portions of the broadcast chain.

Two meters permit you to observe the right channel audio and a user-selected parameter simultaneously. The TOTAL MODULATION meter doubles as the test meter. Pushbutton switches select monitor mode and meter sensitivity, thus allowing a variety of measurements to be made, including the total composite baseband signal, L + R or L-R subchannels, and left or right channels. A front panel switch selects positive or negative modulation metering, and another switch selects whether de-emphasis is switched in or out.

The Model 884's flexibility enables station personnel to measure virtually any parameter of importance to FM stereo broadcasting. These measurements include frequency response, stereo separation, main-to-sub and sub-to-main crosstalk, 19 kHz pilot level, 38 kHz subcarrier suppression, and even AM synchronous noise on the main carrier.

To enable a station to maintain the maximum permissible modulation levels, the Model 884 includes LEDs that light when positive or negative peaks exceed a user-set threshold of modulation set via pushbutton switches. These LEDs are driven by TFT's exclusive Peak Modulation Duration Differentiator circuit (PMDD, patent pending), which distinguishes true modulation peaks from erroneous peaks resulting from tilt, overshoot and ringing, or multipath.

A front panel BNC Test output allows convenient connection to external test equipment such as an oscilloscope (for stereo generator setup of flat baseline and pilot phase).

On the rear panel, balanced left and right channel audio outputs are provided, and a jumper selects whether the de-emphasis is enabled. Additional outputs include an unbalanced composite baseband output and an output for an SCA Monitor.

1.2 Specification

Inputs

RF Section

Frequency Range 88-108 MHz, tunable in 50 kHz steps

On-site RF Input..... 1 to 10 Vrms, 50 ohms, BNC

Antenna Input..... 50 uV to 100 mV, 75 ohms, BNC

Tuning..... 4-digit pushbutton switch, 50 kHz steps

Composite Input..... 3.5 V p-p, 1K ohms, BNC

Meters

Characteristics..... Quasi-peak reading circuit. Approximately
90 ms rise time

Accuracy $\pm 2.0\%$ at all modulation levels

Ac Voltage Range..... 0 to -50 dB in 10 dB steps

Total Modulation/Test Meter

Total Modulation:

Deviation for 100% Indication ± 75 kHz peak-to-peak

Meter Range..... 0 to 133% modulation

Frequency Response..... ± 0.5 dB typical, ± 1 dB max from 30 Hz to 75
kHz

Left Channel Modulation ± 0.5 dB, 50 Hz to 15 kHz

Right Channel Modulation..... ± 0.5 dB, 50 Hz to 15 kHz

L + R ± 0.5 dB, 50 Hz to 15 kHz

L - R..... ± 0.5 dB, 23 kHz to 53 kHz

38 kHz Level	Measures down to -60 dB
Pilot Level.....	Measures down to -60 dB (0.1%). (Accuracy is $\pm 1.0\%$ from 6.0 % to 12%.)
AM Noise.....	Measures AM noise down to -70 dB from 100% AM modulation
De-emphasis.....	Applies de-emphasis to meter display.
Meter Calibration.....	Front panel access to potentiometers that calibrate both meters to 100% modulation.
Positive and Negative Modulation Polarity.....	Allows meter to read positive or negative modulation.

Right Modulation Meter

Right Channel Modulation	Indicates and measures right channel modulation; ± 0.5 dB, 50 Hz to 15 kHz.
--------------------------------	---------------------------------------------------------------------------------

Peak Modulation Indicators

Deviation for 100% Indication.....	± 75 kHz
Peak Level	Set by a front panel 3-digit pushbutton switch in 1.0% steps from 50% to 199% on both positive and negative peaks.
Accuracy (5 kHz tone).....	$\pm 2.0\%$ at 100% modulation
Peak Duration	1 millisecond (internally calibrated)

Modulation Calibrator

A built-in frequency-synthesized calibrator is included for meter and peak flasher calibration of 100% modulation from the front panel. Accuracy: $\pm 1\%$

Front Panel Outputs

Total Modulation/Test Meter Output.....	Output signal selected on the Total Modulation/Test meter; 2.0 V p-p, 1M ohms, BNC.
-----------------------------------------	-------------------------------------------------------------------------------------

Headphones Standard 1/4" jack for headphone connection.

Rear Panel Outputs

Left and Right Audio Output 0 dBm (775 mVrms) at 100%, balanced; barrier Level strip

De-emphasis..... Strappable, in or out

Output for SCA Monitor 1.0 Vrms, 100% modulation into 600 ohms, BNC

Composite..... 5.0 Vrms, 100% modulation, 10K ohms, BNC

Antenna Level Dc voltage proportional to the RF input level:

50 μ V = 0.8 - 0.9 Vdc

100 μ V = 1.0 Vdc

500 μ V = 1.2 - 1.3 Vdc

Performance

(Antenna RF input; measured with external equipment)

Signal-to-Noise Ratio 70 dB at 400 Hz with de-emphasis, composite

Harmonic Distortion 0.2% max (de-emphasized at 1 kHz), composite

Frequency Response..... ± 0.5 dB from 50 Hz to 15 kHz, L and R channels

Separation (L to R and R to L)..... 45 dB typical, 40 dB minimum from 50 Hz to 15 kHz

Crosstalk

(L + R) to (L - R) 50 dB

(L - R) to (L + R) 60 dB

Mechanical and Environmental

Input Power..... 117/230 Vac $\pm 10\%$, 50 to 400 Hz, 40 watts maximum

Operating Temperature.....	0°C to 50 °C (32°F to 122°F); 90% humidity, non-condensing
Size.....	7" (17.78 cm) high x 19" (48.26 cm) wide x 15" (38.10 cm) deep
Net Weight.....	Approximately 18.5 lbs. (8.2 kg)
Shipping Weight.....	Approximately 22.5 lbs. (10.2 kg)

1.3 Model 845 FM SCA Monitor

The Model 845 enables 884 users to monitor up to three user-specified FM subcarrier frequencies. This monitor offers independent off-the-air SCA monitoring, SCA proof-of-performance measurement capability, and specification checks of a subcarrier generator. The 845 also provides uninterrupted subcarrier output and demodulated signal of the subcarriers with optional Service Channel plug-in boards.

1.4 Warranty

TFT Inc., warrants each of its manufactured instruments to meet the specifications when delivered to the **BUYER** and to be free from defects in material and workmanship. TFT will repair or replace, at its expense, for a period of one year from the date of delivery of equipment, all parts which are defective from faulty material or poor workmanship.

Instruments found to be defective during the warranty period shall be returned to the factory with transportation charges prepaid by the **BUYER**. It is expressly agreed that replacement and repair shall be the sole remedy of **BUYER** with respect to any non-conforming equipment and parts thereof, and shall be in lieu of any other remedy available by applicable law. All returns to the factory must be authorized by the **SELLER** prior to such returns. Upon examination by the factory, if any instrument is found to be defective, the unit will be repaired and returned to the **BUYER**, with transportation charges prepaid by the **SELLER**.

Transportation charges for instruments found to be defective within the first 30 days of the warranty period will be paid both ways by the **SELLER**.

Transportation charges for warranty returns wherein failure is found not to be the fault of the **SELLER** shall be paid both ways by the **BUYER**.

Model 884

NO OTHER WARRANTY IS EXPRESSED OR IMPLIED. TFT IS NOT LIABLE FOR CONSEQUENTIAL DAMAGES.

1.5 Claim for Damage in Shipment

Your instrument should be inspected and tested as soon as it is received. The instrument is insured for safe delivery. If the instrument is damaged in any way and fails to operate properly, file a claim with the carrier or, if insured separately, with the insurance company.

WE SINCERELY PLEDGE OUR IMMEDIATE AND FULLEST COOPERATION TO ALL USERS OF OUR PRECISION ELECTRONIC INSTRUMENTS.

PLEASE ADVISE US IF WE CAN ASSIST YOU IN ANY MANNER.

TFT, Inc.
3090 Oakmead Village Drive
Santa Clara, CA 95052
TEL (408) 727-7272
TWX 910-338-0584
FAX (408) 727-5942

SECTION 2 INSTALLATION

2.1 Unpacking and Inspection

Upon receiving the instrument, inspect the packing box and instrument for signs of possible shipping damage. After installation, operate the instrument in accordance with the procedures in Section 3, Operation, of this manual. If the instrument is damaged and fails to operate properly, file a claim with the transportation company or, if insured separately, with the insurance company.

2.2 Power Requirements

The Model 884 is factory-wired to operate from either 117 or 230 Vac. The line frequency must be between 50 and 400 Hz. Maximum power required is 40 watts.

2.3 Model 884 Installation

(Note: Numbers given in parentheses, (), throughout this discussion refer to controls, connectors, and indicators in Figure 3-1, Model 884 Front and Rear Panel Illustration, at the back of Section 3.)

The Model 884 is calibrated and ready for installation into an equipment rack for immediate use. To install, perform the following:

- a. Mount the Model 884 in the equipment rack. Ensure proper environmental conditions exist as specified in Paragraph 1.2 of this manual as well as adequate ventilation.
- b. Ac power is applied through the circuit board under the fuse holder at the rear of the unit. A 117 Vac or 230 Vac power source is required for proper operation. The following voltage selection procedure should be followed to ensure that the proper desired voltage has been selected before applying power.
 - 1) Verify that the circuit board below the fuse holder (25) indicates the desired primary voltage to be used -- either 117 Vac or 230 Vac.

CAUTION

The voltage is configured at the factory for the voltage standard in the country of destination.

- 2) If the desired voltage is not indicated on the circuit board, remove the fuse. Remove the circuit board, turn it over for proper voltage setting, and replace the board by plugging it into the connector.
 - 3) Fuse values differ for each operating voltage and must be changed when the input power connection in J13 is changed. The proper fuse values are listed on a label below the fuse holder. When the proper fuse value is determined, replace the fuse. You may now apply power.
- c. Connect a signal source using the following procedure. Refer to Figure 3-1, Ref. Nos. 22 and 24 for J4 and J5 connectors.
- 1) For off-air monitoring, connect the FM antenna to ANTENNA INPUT jack J5 on the monitor's rear panel.
 - 2) For transmitter measurements (and AM noise measurements), connect the RF sample (1 V to 10 Vrms) to the HI LEVEL RF INPUT jack J4 on the 884 rear panel. Adjust the adjacent RF input level control (23) until the green LED (21) on the rear panel is lit.
 - 3) On the 884 front panel, adjust the FREQUENCY switches (15) for the frequency to be monitored.
- d. For composite measurements set the EXT/INT toggle switch (18) to EXT. Connect a signal to the COMPOSITE INPUT jack, J3, (20) and adjust the level with the COMPOSITE INPUT LEVEL ADJ (adjacent to the jack) for 100% on the TOTAL MODULATION meter. (The level must be greater than 3.5 V p-p into 1K ohms.) The unit then operates as a precision stereo demodulator.

2.4 Model 845 SCA Monitor Installation

The TFT Model 845 SCA Monitor is connected to the Model 884 through the composite output at J1, TO SCA MONITOR (16), on the rear panel. Use a BNC cable.

SECTION 3 OPERATION

3.1 General Discussion

The Model 884 is a rack-mounted monitor that allows the user to operate it at the transmitter site or off-the-air at the studio. In addition to high and low level RF inputs, the monitor includes a composite input to allow measurements of composite signals such as a stereo generator. The user can measure virtually any parameter important to FM stereo broadcasting using the front panel pushbutton function and attenuator switches and meters as well as the front and rear panel jacks and terminal strips.

Two front panel meters -- TOTAL MODULATION/TEST and RIGHT CHANNEL MODULATION -- allow the user to observe total modulation or left channel modulation and right channel modulation simultaneously. In addition, the TOTAL MOD/TEST METER pushbutton switches select monitor mode and meter sensitivity, thus allowing a variety of measurements to be made.

PEAK MODULATION LEDs simplify observation of excessive positive or negative peaks and display true modulation peaks. (The circuit distinguishes erroneous peaks resulting from tilt, overshoot and ringing, or multipath.) The peak threshold is set by pushbutton switches.

Calibration adjustments are provided for the meters and peak flashers as well as the 38 kHz PLL phase calibration.

3.2 Turn-on and Warm-up

The 884 contains no Power On/Off switch. The monitor is on whenever connected to an ac source. When the unit is on, the meter's lights are illuminated. The 884 should be allowed to warm up for approximately 30 minutes before use. Although calibrated at the factory, after warm-up the Meter Calibration (Paragraph 5.1.1), the Peak Modulation Calibration (Paragraph 5.1.2), and the Stereo Separation Adjustment (Paragraph 5.1.3) procedures in this manual should be performed.

3.3 Controls, Connectors, and Indicators

This section contains summary descriptions of the Model 884 front and rear panel controls, connectors, and indicators. Refer to Figure 3-1, Model 884 Front and Rear Illustration, at the end of this section.

Front Panel (Figure 3-1)

Ref. No.	Name	Function
1	+ PEAK LED	Lights whenever the positive modulation peaks exceed the percentage set on the % PEAK pushbutton switches (4).
2	PEAK MODULATION CAL adjust	Calibrates the + and - peak LEDs when the METER CAL pushbutton is depressed.
3	- PEAK LED	Lights whenever the negative modulation peaks exceed the percentage set on the associated pushbutton switches (4).
4	% PEAK pushbutton switches	Sets the modulation threshold for the + and - PEAK LEDs. The appropriate LED (+ or -) will light when the percent set on the switches is exceeded. See Section 4, Paragraph 4.5 of this manual for a further discussion.
5	TOTAL MODULATION/TEST meter	Indicates the parameter chosen by the TOTAL MOD/TEST METER function and attenuator switches.
6	TOTAL MODULATION/TEST meter adjust	Mechanical adjust for zeroing the TOTAL MODULATION/TEST meter.
7	RIGHT CHANNEL MODULATION meter	Indicates right channel modulation independent of selected function switch positions.
8	RIGHT CHANNEL MODULATION adjust	Mechanical adjust for zeroing the RIGHT CHANNEL MODULATION meter
9	TEST OUTPUT jack	BNC jack with signal that is selected at the TOTAL MOD/TEST METER function

- switches for connection to external test equipment.
- | | | |
|----|--------------------------------------------|-----------------------------------------------------------------------------------------------------------------------------------------------------------------------------------------------------------------------------------------------------------------------------------------------------------------------------------------------------------------------------------------------------------------------------------------------|
| 10 | 19 KHz PILOT lamp | Lights when 19 kHz pilot signal is received. |
| 11 | TOTAL MOD/TEST
METER function switches | Pushbutton switches select the function and attenuation that are indicated on the TOTAL MODULATION/TEST meter. Four switches may be selected at one time: (1) + or - selects either positive or negative modulation peaks. (2) DE-EMPH switches in the de-emphasis circuit. (3) Attenuation switches from 0 dB to -50 dB (100% to 0.3%) insert the attenuation selected. (4) Signal select switches provide the selected signal to the meter. |
| 12 | METER CAL switch and
associated trimmer | When the switch is depressed, the trimmer is used to calibrate both meters to 100% modulation. See Paragraph 3.2 for the calibration procedure. |
| 13 | STEREO SEPARATION
adjust | This adjustment ensures that the best channel separation is attained in order to make the best stereo measurements possible. |
| 14 | HEAD PHONE jack | For connecting headphones to the 884. |
| 15 | FREQUENCY pushbutton
switches | Set of switches used to select the frequency to be monitored, either off-air or transmitter sample. |

Rear Panel (Figure 3-1)

- | | | |
|----|----------------------------------------|-------------------------------------------------------------------------------------------|
| 16 | TO SCA MONITOR jack,
J1 | Composite output available to drive a Model 845 SCA Monitor. |
| 17 | COMPOSITE OUTPUT
jack, J2 | Composite signal available on this jack for external monitoring/testing. |
| 18 | EXT COMPOSITE INPUT,
EXT/INT switch | Selects the internal or external composite signal to be applied to the metering circuits. |

19	EXT COMPOSITE INPUT, LEVEL ADJ control	Adjusts the level of the external composite input.
20	EXT COMPOSITE INPUT jack, J3	Jack used to monitor an external composite signal (>3.5 V p-p).
21	HI LEVEL RF INPUT SET LED	LED lights when the high level RF input has been adjusted properly.
22	RF INPUT, HI LEVEL jack, J4	Used to connect the transmitter RF sample (between 1 V and 10 V (50 ohms).)
23	HI LEVEL INPUT SET control, R2	Adjusts attenuation to high level RF input to the proper operating level for AM noise measurements.
24	ANTENNA INPUT jack, J5	Used to connect an off-air signal from an antenna (between 50 uV and 100 uV (75 ohms))
25	Fuse and ac voltage set	Fuse holder and terminal board for setting the ac voltage to either 117 Vac or 230 Vac.
26	Ac power cord connector	Connector for either 117 Vac or 230 Vac power.
27	ANT LEVEL table	Table indicating antenna input levels and corresponding dc voltages available at the ANT LEVEL terminals of barrier strip TB 2 (28).
28	TB 2 terminal strip	Terminal strip containing terminal connections for the de-emphasis strapping, left and right channel audio, and the antenna level dc output. The following are the terminal locations for these outputs:
	75 us DE-EMPH, terminals 1 and 2	Short terminals 1 and 2 together to allow the de-emphasis circuit to be switched into the left and right channel demodulated outputs on the barrier strip.
	L CH and R CH AUDIO outputs: terminals 3 and 5 for the left audio channel; terminals 6 and 8 for the right audio channel	Demodulated left and right audio outputs.

ANT LEVEL, terminals 9
and 10

Provides dc voltage in proportion to the
received signal strength.

3.4 Measurements

The Model 884 performs a variety of measurements. This section discusses the procedures required for making those measurements.

3.4.1 Main Channel Modulation (L + R)

Press the L + R function switch and the 0 dB (100%) attenuation switch. The TOTAL MODULATION/TEST meter will indicate the main channel modulation directly in percent. A fully modulated left or right channel only signal will indicate 45% on the meter; a fully modulated L = R signal will indicate 90%; and a fully modulated L = -R signal will indicate 0.

3.4.2 Stereo Subchannel Modulation

Press the L - R function switch and the 0 dB (100%) attenuation switch. The TOTAL MODULATION/TEST meter will indicate the stereo subchannel modulation directly in percent. A fully modulated left or right channel only signal will indicate 45% on the meter; a fully modulated L = -R signal will indicate 90%; and a fully modulated L = R signal will indicate 0.

3.4.3 Pilot Carrier Modulation

Press the 19 kHz function switch and the -20 dB (10%) attenuation switch. The TOTAL MODULATION/TEST meter will indicate the pilot modulation level, with 100% meter reading indicating 10% modulation. Correct pilot modulation level is between 8% and 10%. It can be measured when program modulation is present; slight "bouncing" of the meter needle is normal under this condition.

3.4.4 38 kHz Subcarrier Suppression

To measure 38 kHz subcarrier suppression, perform the following:

- a. Apply a modulating signal between 5 kHz and 15 kHz to the left channel of the stereo generator and adjust its level to indicate 90% on the TOTAL MODULATION/TEST meter.
- b. Press the 38 KHz function switch.
- c. With the TOTAL MOD/TEST METER attenuation switches, select an attenuation that provides a usable reading on the TOTAL MODULATION/TEST meter. The 38 kHz subcarrier suppression is the algebraic sum

of the meter reading and the attenuation inserted. For example, a meter reading of -2 dB with the -50 dB meter attenuation switch depressed denotes a 38 kHz subcarrier suppression of 52 dB below 100% modulation.

3.4.5 Stereo Separation

Left and right channel modulated signals can be measured independently on the Model 884. The following paragraphs describe the procedures used to measure these signals.

3.4.5.1 Left Channel Modulated Signal

To measure the "Left into Right" channel separation, perform the following:

- a. Apply a modulating signal between 50 Hz and 15 kHz to the left channel and adjust its level to indicate 90% on the TOTAL MODULATION/TEST meter.
- b. Press the R function switch.
- c. With the TOTAL MOD/TEST METER attenuation switches, select an attenuation that provides a usable reading on the TOTAL MODULATION/TEST meter. The channel separation is the algebraic sum of the meter reading and the attenuation inserted, less approximately 1 dB (0.915 dB) to account for the 90% left channel modulation level. For example, a meter reading of -2 dB with the 1%/40 dB meter attenuation switch depressed denotes a stereo channel separation of 41 dB.

3.4.5.2 Right Channel Modulated Signal

To measure the "Right into Left" channel separation, perform the following:

- a. Press the R function switch.
- b. Press the 0 dB (100%) TOTAL MOD/TEST METER attenuation switch.
- c. Apply a modulating signal between 50 Hz and 15 kHz to the right channel and adjust its level to indicate 90% on the TOTAL MODULATION/TEST meter.
- d. Press the L function switch.
- e. With the TOTAL MOD/TEST METER attenuation switches, select an attenuation that provides a usable reading on the TOTAL MODULATION/TEST meter. The channel separation is the algebraic sum of the

meter reading and the attenuation inserted, less 1 dB to account for the 90% right channel modulation level.

3.4.6 Main Channel to Subchannel Crosstalk

To measure main channel to subchannel crosstalk, perform the following:

- a. Press the TOTAL MOD/TEST METER L + R function switch and the 0 dB (100%) attenuation switch.
- b. Apply an L + R modulating signal to the stereo generator and adjust the level for a 90% reading on the TOTAL MODULATION/TEST meter.
- c. Press the L - R function switch.
- d. With the TOTAL MOD/TEST METER attenuation switches, select an attenuation that provides a usable reading on the TOTAL MODULATION/TEST meter. The crosstalk measured is the algebraic sum of the selected attenuation and the meter reading, less 1 dB to account for the 90% modulation setting.

3.4.7 Subchannel to Main Channel Crosstalk

To measure subchannel to main channel crosstalk, perform the following:

- a. Press the L - R function switch and the 0 dB (100%) TOTAL MOD/TEST METER attenuation switch.
- b. Apply an L - R modulating signal to the stereo generator and adjust the level for a 90% reading on the TOTAL MODULATION/TEST meter.
- c. Press the L + R function switch.
- d. With the TOTAL MOD/TEST METER attenuation switches, select an attenuation that provides a usable reading on the TOTAL MODULATION/TEST meter. The crosstalk measured is the algebraic sum of the selected attenuation and the meter reading, less 1 dB to account for the 90% modulation setting.

3.4.8 FM Noise

To measure FM noise, perform the following:

- a. Apply an L + R modulating signal to the transmitter under test and adjust the level for a 90% reading on the TOTAL MODULATION/TEST meter.

- b. Turn off all transmitter modulation.
- c. Press the TOTAL MOD (total modulation) switch.
- d. With the TOTAL MOD/TEST METER attenuation switches, select an attenuation that provides a usable reading on the TOTAL MODULATION/TEST meter. The algebraic sum of the selected attenuation and the meter reading is the FM signal-to-noise ratio.

NOTE

If a de-emphasized reading is required, the DE-EMPH function switch must be depressed.

3.4.9 Distortion

To measure distortion, perform the following:

- a. Apply a modulating signal to the desired audio channel.
- b. Connect a distortion analyzer to the front panel TEST OUTPUT and select the L or R switch.

3.4.10 Pilot Frequency

To measure the pilot frequency, perform the following:

- a. Connect a frequency counter to the TEST OUTPUT jack on the 884 front panel and depress the 19 KHz function switch.
- b. The transmitted pilot frequency is read directly on the counter.

3.4.11 Peak Modulation

Positive and negative peak modulation is read directly on the front panel using the PEAK MODULATION flashers and switches. To read peak modulation, perform the following:

- a. Calibrate the % PEAK flashers so that the lights just come on in the CAL mode. For peak modulation calibration, see Section 5, Paragraph 5.1.2 of this manual.

- b. Set the % PEAK switches to the desired peak modulation level for the peak flashers. The peak flashers will be triggered if the modulation peaks exceed the % PEAK switch setting and the pulsewidth of the peaks exceed 1 millisecond duration.

3.4.12 Synchronous and Asynchronous AM Noise

To measure synchronous or asynchronous noise perform the following:

NOTE

This procedure applies to both synchronous and asynchronous AM noise measurements; however, synchronous AM noise is measured **with FM modulation.**

- a. Apply the RF sample to the RF INPUT HI LEVEL jack.
- b. Adjust the HI LEVEL RF INPUT SET until the SET LED ON lamp lights.
- c. Depress the AM NOISE function switch on the front panel.
- d. With the meter attenuator switches, select an attenuation that provides a usable reading on the TOTAL MODULATION/TEST meter. The algebraic sum of the selected attenuation and the meter reading is the AM noise level.

NOTE

The AM noise is read from the HIGH LEVEL RF INPUT only.

This document contains proprietary information and is delivered upon the expressed condition that it will not be used directly or indirectly in any way detrimental to the interest of TET Inc.

REVISIONS				
REV	DESCRIPTION	DR	DATE	APPD
A	PROD RELEASE	FAK	1/19/88	

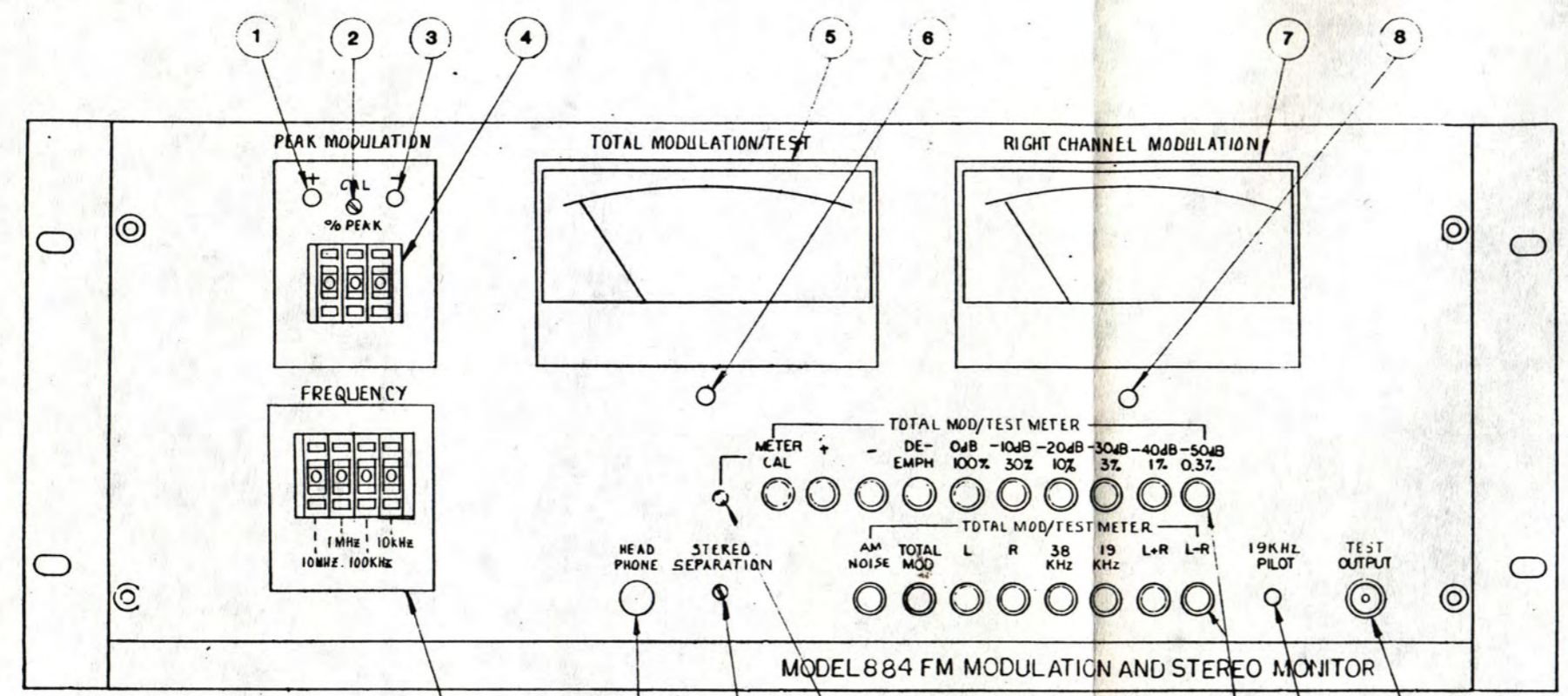

FRONT PANEL

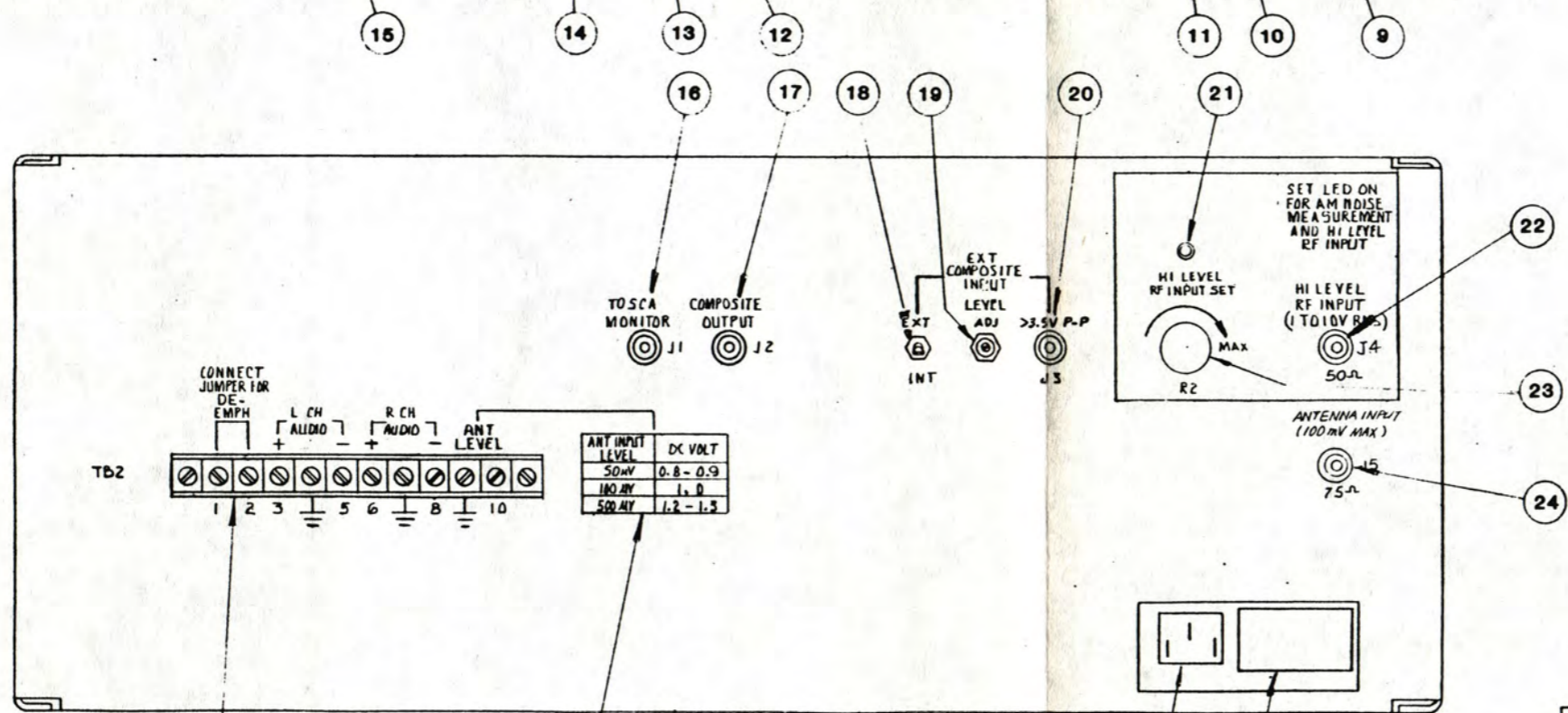

REAR PANEL

FIG. 3-1

ITEM	QTY	PART NO	NOMENCLATURE OR DESCRIPTION
			TET 3090 DAVE MEAD VILLAGE DR SANTA CLARA CA 95051 INC 408-227-7777 TWX 910-338-0544
			MODEL 884 FRONT AND REAR ILLUSTRATION
DR BY		WJG	CODE IDENT NO
CHK BY		J.S. LPHV	SIZE
ENGR		J.S. LPHV	DRAWING NO
MFG		BT	REV
			D 6600-2523 A
			SCALE FULL
			DO NOT SCALE PRINT
			SHEET 1 OF 1

SECTION 4

THEORY OF OPERATION

4.1 General Discussion (Figure 6-1)

The Model 884 FM Modulation and Stereo Monitor contains a low level RF preselector, FM monitor, stereo baseband monitor, and a peak detector. Four major circuit boards perform these functions: RF Preselector A1, FM Demodulator A3, FM Stereo A4, and Display Driver A6. The block diagram, Figure 6-1, is located in Section 6 of this manual.

RF input from either transmitter or antenna enters the 884 rear panel and is routed to RF Preselector A1. Here the signal is padded through the attenuated circuit to a balanced mixer. The 900 kHz IF signal is sent to a low pass filter. This IF is then routed to the Demodulator Board A3.

FM Demodulator A3 receives the 900 kHz IF, demodulates the signal, and delivers a pulsed output that is filtered and amplified. The resulting signal is filtered and routed to the FM Stereo Board. On A4 the composite signal is filtered and returned to A3 and to the front panel monitors and test outputs. Separation adjust is also performed on A4.

Positive and negative modulation are used to drive the front panel PEAK flashers on A6, the Display Driver. Each modulation peak is compared in a peak detector to a voltage obtained from a constant current source by means of resistances selected by pushbutton switches on the PEAK MODULATION flashers. The pulse outputs produced by the peak detectors when modulation exceeds user preset values are applied to the front panel LED flashers, which light for approximately 2 seconds.

4.2 RF Preselector A1 (Figure 6-3)

The RF input to the monitor comes from the sampling point of the transmitter as a high level signal or from an antenna as a low level signal. The high input level enters the 884 through the rear panel RF INPUT HI LEVEL (50 ohm) connector J4. The signal is fed through the adjustable attenuator HI LEVEL RF INPUT SET R2 to the ANTENNA INPUT terminal and to the AM detection circuit. This high level input signal is adjusted to 1 Vrms and also goes to an AM detector which drives a level detector to light the rear panel LED (Ref. No. 21 in Figure 3-1) when the RF level is too low or too high.

When the antenna input is used through the rear panel ANTENNA INPUT (75 ohm) connector J5, the signal is amplified in the RF amplifier, then mixed with a synthesized local oscillator. The synthesized frequency is selected by the user by tuning the frequency select pushbutton switches on the 884 front panel. The result is a 10.7 MHz IF which goes to a linear phase filter, an IF amplifier, and a second mixer with a 9.8 MHz controlled crystal oscillator. The resulting frequency is a 900 kHz IF, which is then passed through a low pass filter made up of L7, L8, C38, C60, C61 and L3, L10, C76, C87, C88. The IF is passed to J7.

4.3 FM Demodulator A3 (Figure 6-5)

The 900 kHz IF signal which is applied to the FM Demodulator Board A3 through a relay to a pulse counting FM demodulator circuit. The limiting amplifier, U1, is driven into saturation to provide limiting. U2 is a one-shot multivibrator acting as a pulse averaging discriminator. It delivers a pulsed output whose frequency is the same as the IF but with a fixed pulse width. The duty cycle in the output pulse train varies with the modulation and the audio is recovered by passing the discriminator output through a low pass filter. Transistors Q1 thru Q4 make up the clamping circuit.

The low pass filter consists of L2 and L3 and amplifier U7. This circuit provides a flat response to 100 kHz and linear phase in order to give good stereo measurements. The frequency response rolls off after 100 kHz to eliminate any residual 900 kHz. Amplifier U10 raises the audio level to 1 Vrms.

The monitor calibration circuit consists of U3 thru U6. The 358 kHz output of the timebase is divided down to 4.48 kHz, which is then used to gate the 200 kHz on and off at a 4.48 kHz rate. This simulates a 100% modulated input. When the front panel METER CAL switch is depressed, this calibration signal is fed into limiting amplifier U1 and discriminator U2 in place of the 900 kHz IF. After passing through a 7.5 kHz calibration low pass filter, it is amplified by U8, which is adjusted by CAL LEVEL ADJUST R29 to give a 100% reading on the TOTAL MODULATION/TEST meter. The signal can also be used to check meter and flasher calibration. The circuit is very stable and can be used to correct drifts in the one-shot discriminator U2 and the meter amplifiers.

The output of the one-shot discriminator is also fed to a separate low pass filter that cuts off at approximately 85 kHz to eliminate any wideband noise spikes from the preselector. The filtered signal is adjusted to the proper level and fed to the peak flasher drivers.

Inverting amplifier U11 is a unity-gain operational amplifier. In the monitor mode, the recovered audio from the discriminator is delivered through the low pass filter and the amplifier to the "+" terminal of switch S1. When the front panel TOTAL MOD/TEST METER "+" is depressed, the positive modulation peaks are monitored on the TOTAL MODULATION/TEST meter. The audio is also inverted by U11 and fed to the "-" ter-

minal of S1 so that when the TOTAL MOD/TEST METER "-" function switch is depressed, the TOTAL MODULATION/TEST meter monitors negative modulation peaks.

The resulting signal from the Pulse Counting FM Demodulator circuit is fed through a relay to various circuits -- the Total Modulation Meter, EXT STEREO SIGNAL, PLL Stereo Decoder, and Peak Modulation Duration Differentiator (PMDD) circuits (see Paragraph 4.5) -- and to the rear panel EXT switch as the total composite signal.

Using the COMPOSITE INPUT EXT/INT switch on the rear panel, the user can externally measure the stereo signal.

4.4 FM Stereo A4 (Figure 6-7)

On A4 the composite signal from the input amplifier, U3, is applied to the stereo demodulator. There it is combined with a precision 38 kHz square wave, derived from the 19 kHz pilot signal, to provide the right and left channel outputs. In normal monitoring, the RIGHT function switch and the 0 dB (100%) attenuator switch are depressed. The function switches are mechanically interlocked.

The TOTAL MODULATION/TEST and RIGHT CHANNEL MODULATION meters on the 884 front panel provide the user with monitor and test indications. The RIGHT CHANNEL MODULATION meter only reads right channel modulation. The TOTAL MODULATION/TEST channel reads left channel modulation and all test functions that can be selected by the front panel pushbutton switches.

The left channel output of the stereo demodulator is fed through a 15 kHz low pass filter, the TOTAL MOD/TEST function switch, and the selected attenuator to a detector. The dc output from this detector also drives the RIGHT CHANNEL MODULATION test meter.

The right channel output is fed through a 15 kHz low pass filter, amplifiers, detector, and to the RIGHT CHANNEL MODULATION meter.

The precision 38 kHz square wave required by the stereo demodulator is supplied by a phase-locked loop (PLL). The 19 kHz pilot signal, extracted from the composite signal by the 19 kHz bandpass filter, is applied to the phase-locked loop as the reference signal. The output of the PLL is divided by two to provide 38 kHz for the stereo demodulator and divided again by two to provide a 19 kHz comparison input to the PLL. Since the phase-locked loop -- when properly adjusted -- keeps the two 19 kHz inputs locked in phase, the 38 kHz output will also be locked to the 19 kHz reference, as is required by the stereo demodulator.

The 19 kHz detector -- consisting of amplifier U4, rectifier CR1, and dc amplifier Q2 -- lights the front panel 19 KHz PILOT LED when there is a pilot carrier present in the composite input.

The measurement circuits located on this board consist of filters used to extract the desired information from the composite signal, attenuator network with its selector switches, TOTAL MODULATION/TEST meter, and the associated amplifiers and function switches.

The main channel 15 kHz low pass filter provides the main channel output for FM signal-to-noise measurement, left plus right (L + R) main channel measurement, and TOTAL MODULATION/TEST meter calibration.

The left minus right (L - R) stereo channel, 23 - 53 kHz filter, provides the stereo channel output for measuring its amplitude.

The 15 kHz filters provide outputs for the left (L) and right (R) channel meters and the TEST OUTPUT front panel connector.

When the desired function and attenuator switches are depressed, the FM Stereo Board A4 picks up the signal and routes it to the TOTAL MOD/TEST INPUT on FM Demodulator A3. The signal is passed through U15 to the TOTAL MOD/TEST METER circuit.

4.5 Display Driver A6 (Figure 6-10)

Display Driver A6 is the PC board associated with peak modulation monitoring. (See Figure 3-1, Ref. Nos. 1-4, for front panel location of the the PEAK MODULATION flashers.) The circuits associated with this Peak Modulation Duration Differentiator (PMDD) create a window that is set at 1 millisecond to separate overshoot, multipath, noise interference, etc. from true peak modulation.

Operational amplifier U4 on Display Driver A6 acts as a constant current generator for the PEAK DURATION switch resistors. A constant reference voltage input to U4 is adjusted by the PEAK CAL adjust on the front panel and the % PEAK pushbutton switches to 100%, and depressing the METER CAL pushbutton switch. Adjusting the PEAK CAL control will trigger the peak detectors. (The detectors should not be triggered if the switches are set at 101%.) See Paragraph 5.1.2 for the calibration procedure.

Q1 gain is set by potentiometer R41 in the feedback circuit. Flasher duration is approximately 1 millisecond. The Peak Flasher circuit has been calibrated so that a 100% indication set by the % PEAK switches selects a dc voltage out of Q1 exactly equal to ± 75 kHz peak modulation of the carrier. Other switch settings select respective resis-

tance values that produce the required reference voltage to Q1 for the percentage modulation indicated by the switches.

The peak modulations are compared against the peak modulation and reference level set by the front panel % PEAK switch, with U2 and U3 providing output pulses for the positive and negative peaks, respectively. Pin 12 of U2 and pin 7 of U5 and their associated components form a pulsewidth differentiating network. The pulsewidth that can pass through this network is determined by R41.

When the modulation amplitude exceeds the reference voltage from U4, U3 produces an output pulse. The pulse goes through a series of gates and is routed to U8 to become the CLOCK SIGNAL for the Display Driver, A5. The pulse is also applied to one-shot U7 to drive the front panel PEAK "+" LED flasher through Q4.

The output pulse from U3 through one-shot U7 also produces the negative pulse that drives the front panel PEAK "-" LED flasher through Q2.

SECTION 5 MAINTENANCE

5.1 Calibration

The 884 has been calibrated at the factory and is ready for use after proper installation and warm-up (Section 2, Paragraph 2.3); however, some periodic calibrations and adjustments should be performed. The meter, peak detector, and stereo measurement circuits require such maintenance. The procedures for these checks are discussed in the following paragraphs.

5.1.1 Meter Calibration

To calibrate the meter circuits, perform the following using the TOTAL MOD/TEST METER functions:

- a. Press the METER CAL pushbutton in.
- b. Press the DE-EMPH pushbutton so it is out.
- c. Press the 0 dB (100%) pushbutton in.
- d. Press the TOTAL MOD pushbutton in.
- e. Adjust the METER CAL control for 100%, 0 dB, on the TOTAL MOD/TEST meter.

5.1.2 Peak Modulation Calibration

To calibrate the peak detector, perform the following procedure in the order given:

- a. Press the METER CAL pushbutton switch in.
- b. Set the % PEAK pushbutton switches to 100.
- c. Adjust the PEAK CAL control until the + and - LEDs are on.
- d. Set the % PEAK pushbutton switches to 101.
- e. If the + and - lights are on, readjust the PEAK CAL control until the lights go out. (A delay of 2 seconds may be encountered.)

5.1.3 Stereo Separation Adjustment

To adjust stereo separation, perform the following:

- a. Apply a composite signal (19 kHz, L + R) from a stereo generator to the 884 rear panel EXT COMPOSITE INPUT BNC connector. The stereo signal should be modulated at 1 kHz from the stereo generator.
- b. On the 884 rear panel, set the COMPOSITE INPUT EXT/INT switch to the EXT position.
- c. Depress the 884 front panel L + R function switch.
- d. Adjust the LEVEL ADJ potentiometer on the 884 rear panel for the maximum reading by turning this adjust to the fully clockwise position (CW).
- e. Adjust the level control on the stereo generator for 100%.
- f. Depress the 884 front panel 19 KHz and the -20 dB (10%) function switches. The 19 KHz LED on the 884 should be on and you should read 10% on the TOTAL MODULATION/TEST meter.
- g. Feed the stereo generator a left channel only signal and depress the 884 L function switch. You should read 100% on the TOTAL MODULATION/TEST meter.
- h. Depress the R function switch on the 884. Adjust the STEREO SEPARATION potentiometer for a minimum reading on the TOTAL MODULATION/TEST meter (approximately -60 dB), using the appropriate attenuator switches to read the meter.
- i. Feed a right channel signal to the stereo generator. Depress the L function switch on the 884. You should read better than - 60 dB on the TOTAL MODULATION/TEST meter.
- j. If the reading in step i above is better than -60 dB, you are finished with this adjustment procedure. If the reading is not better than -60 dB, repeat steps g thru i above.

SECTION 6

DIAGRAMS AND SCHEMATICS

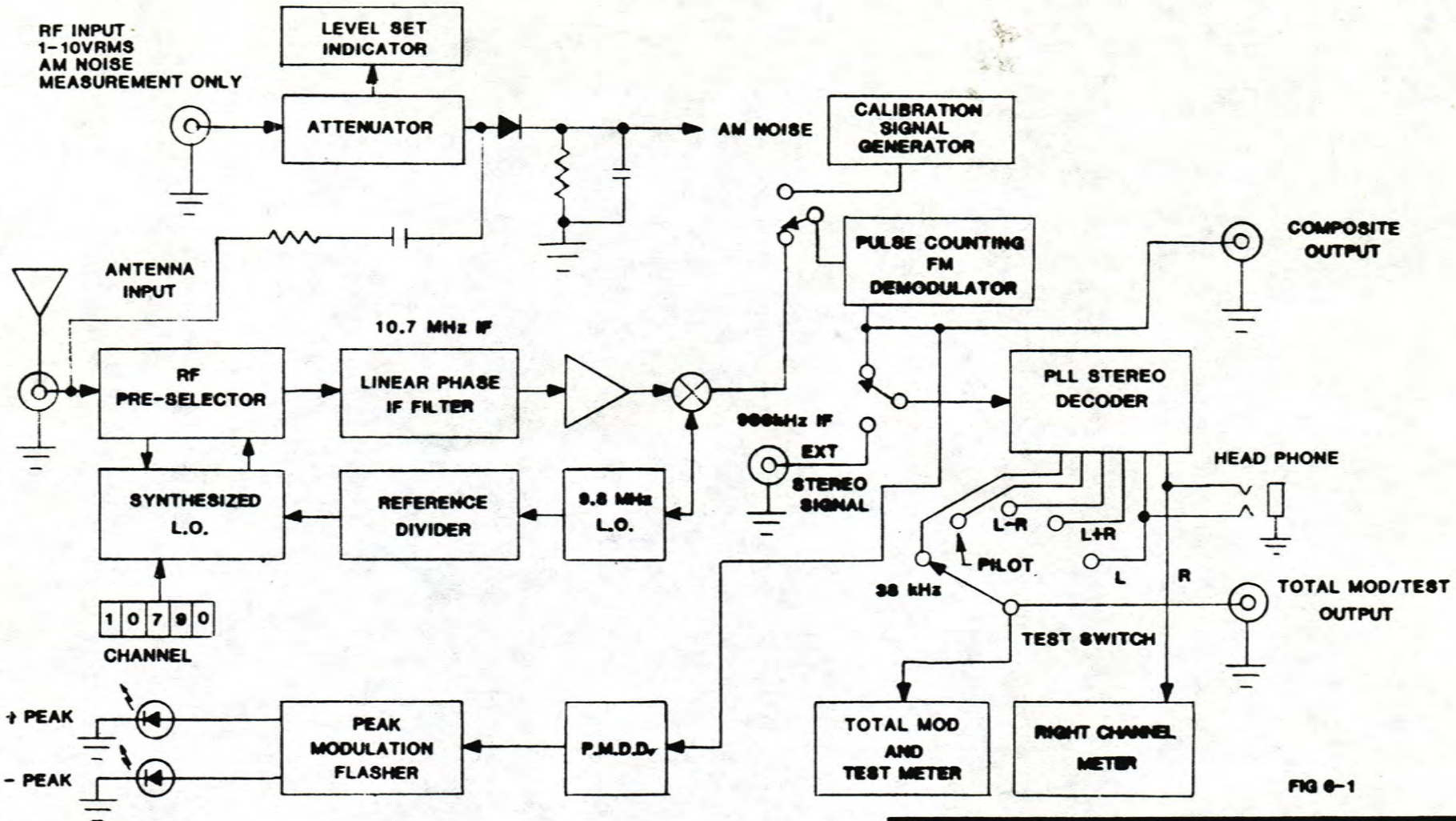

FIG 6-1

MEM TIME & FREQUENCY TECHNOLOGY INC.

**88.4 FM STEREO MONITOR
BLOCK DIAGRAM**

APPROVALS	DATE
DRAWN C-S HO	2-2-88
ENGR Y.S. LAW	3/15/88
MFG.	
D.A.	

SIZE A	FBCM NO.	DWG. NO. 6600-2530	REV. B
SCALE NONE		SHEET 1 OF 1	

REVISIONS			
REV	DATE	BY	APPROVED
A	7-6-88	PROD RELEASE PER ECOLTSA	

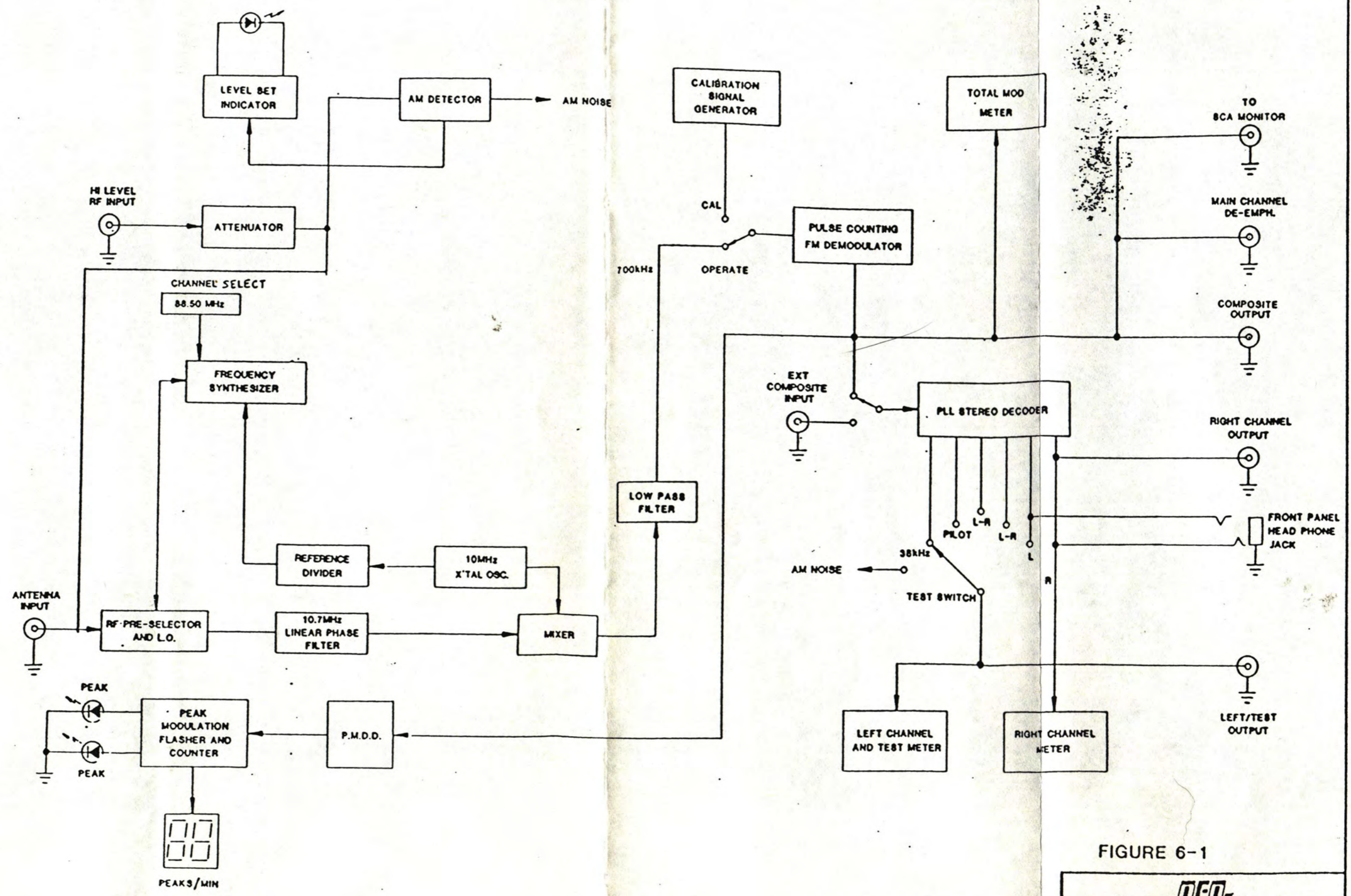

FIGURE 6-1

APPROVALS		DATE				884 FM STEREO MONITOR BLOCK DIAGRAM	
DESIGNER	C-S NO	7-6-88					
ENGINEER	Y-S-LAW	7-6-88		SIZE	FORM NO.	DWG. NO.	REV.
				C		6600-2597	A
				SCALE	1/8W	SHEET	1 OF 1

This document contains proprietary information and is delivered upon the expressed condition that it will not be used directly or indirectly in any way detrimental to the interest of TPT Inc.

DWG. NO. 6600-2527

REVISIONS				
REV	DESCRIPTION	DN	DATE	APPD
A	RELEASED TO PRODUCTION		6/2-3-89	

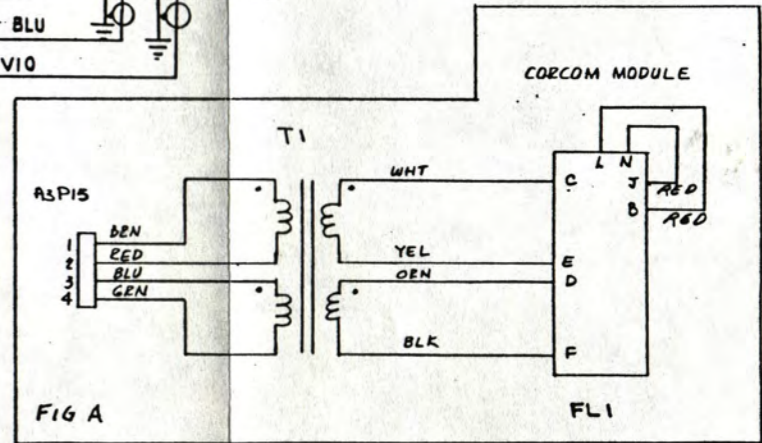
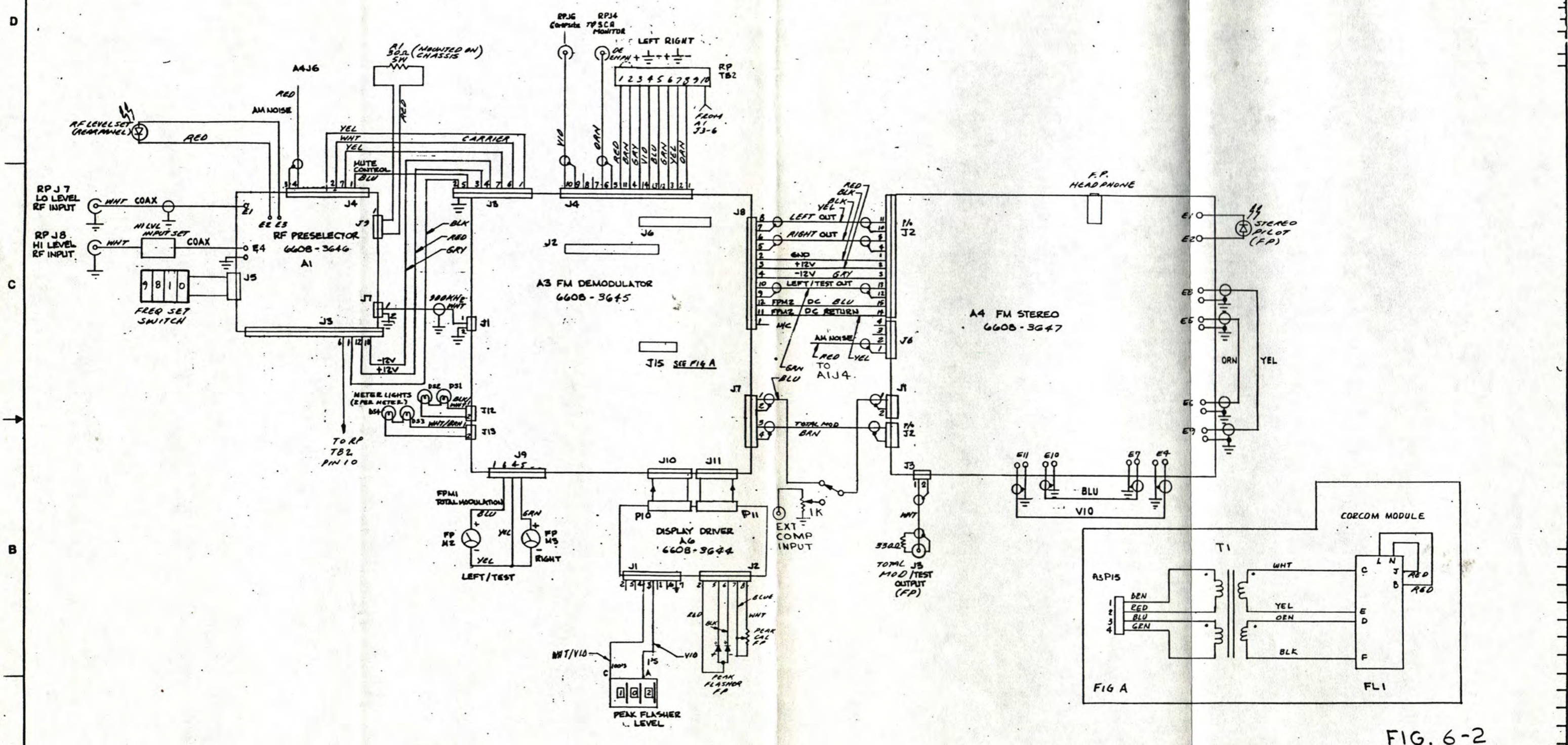

FIG. 6-2

ITEM	QTY	PART NO.	NOMENCLATURE OR DESCRIPTION
MATERIAL			NET 3090 OAKMEAD VILLAGE DR. SANTA CLARA, CA. 95051 (408) 727-7272 TWX 910-338-0594
FINISH			INTER-CONNECT DIAGRAM MODEL 884
DR. BY: J. KRAFT		2/2-89	CODE IDENT. NO. SIZE DRAWING NO. REV.
CK. BY: R.L.		3-15-89	
ENGR. Y.S. LAW		3/5/89	SCALE DO NOT SCALE PRINT SHEET 1 OF 1
APP.:			

SPECIFICATIONS UNLESS OTHERWISE NOTED:
 ANGULAR - 2°
 DECIMAL - 2 PLACE ±
 3 PLACE ±
 BREAK - .010MIN
 SURFACE ROUGHNESS - MICROINCHES RMS-MAX.
 DIAMETERS - CONCENTRIC WITHIN .005 TH.
 FILLET RADIUS - MAX
 THREADS - CLASS 2 MARK IN ACCORDANCE WITH TPT SPEC 5300-1050

884	5000-0884
MODEL	NEXT ASSY
APPLICATION	

This document contains proprietary information and is not to be used directly or indirectly in any way other than in the interest of TTY Inc.

REV	DESCRIPTION	REV	DATE	APPD
A	RELEASED TO PRODUCTION		8-2-89	
B	REVISED PER ECD 1750		11-21-89	

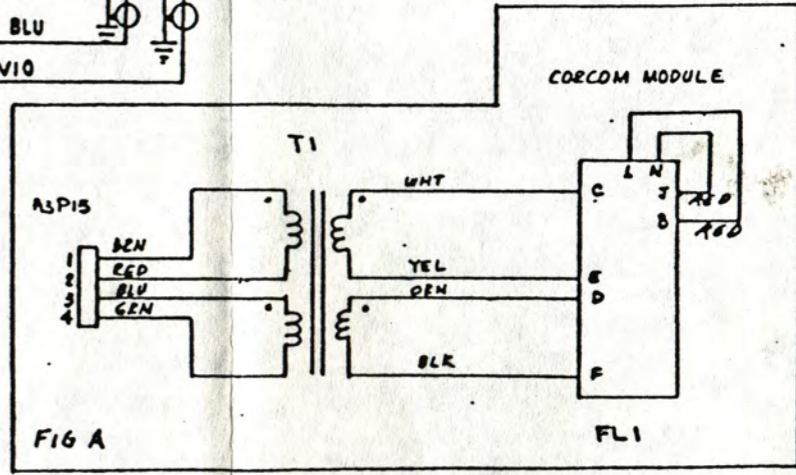
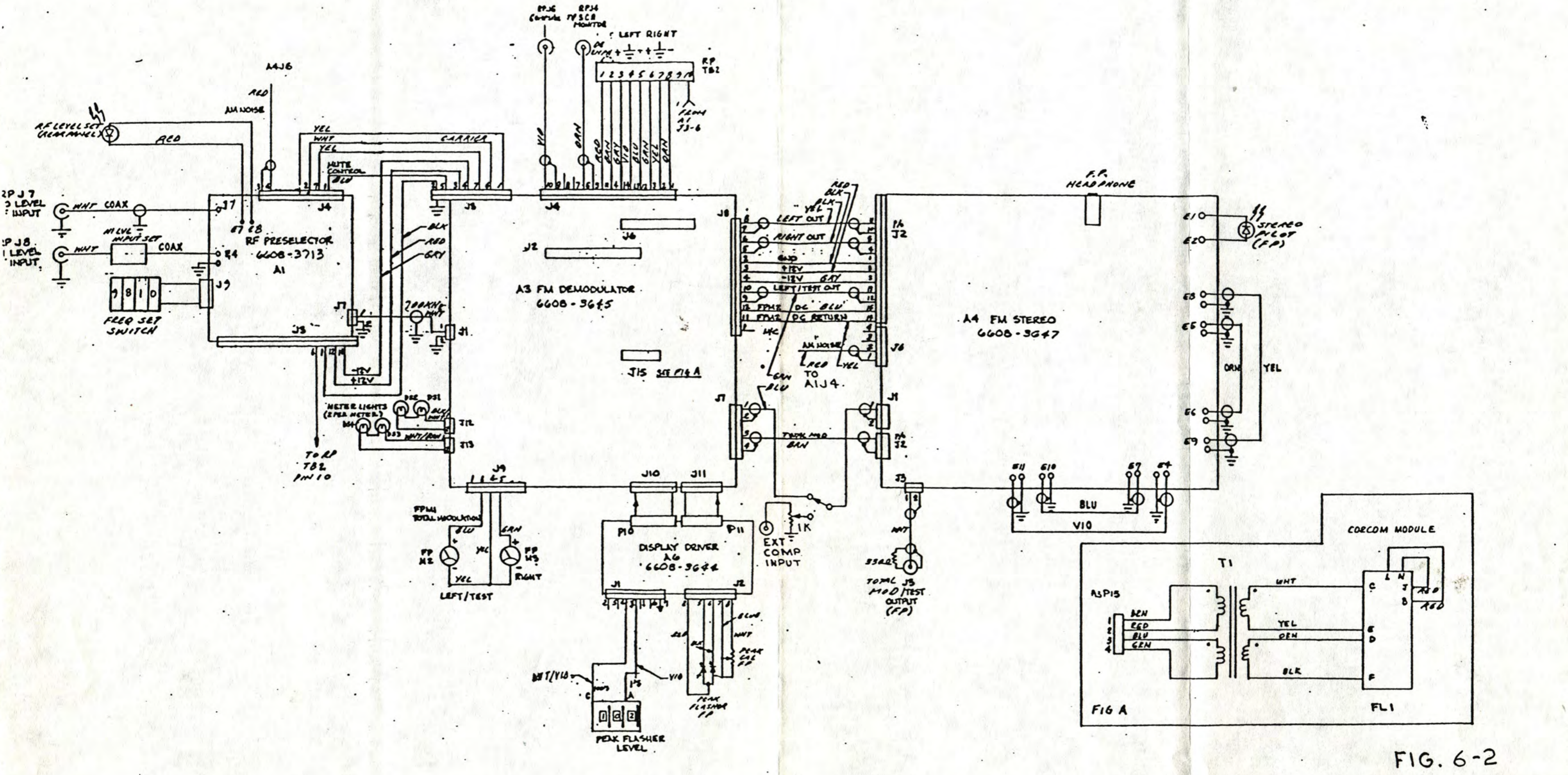

FIG. 6-2

ITEM	QTY	PART NO.	NOMENCLATURE OR DESCRIPTION
			<p>GENERAL</p> <p>3090 OAKMEAD VILLAGE DR. SANTA CLARA, CA. 95051 (408) 727-7272 TWX 910-338-0584</p>
			<p>INTER-CONNECT DIAGRAM MODEL 884</p>
<p>DR. BY: <i>ALM</i> 2-1-89</p> <p>CL. BY: <i>ELC</i> 2-15-89</p> <p>ENGR: <i>Y.S. LAU</i> 11-1-89</p> <p>INPL:</p> <p>D.A.:</p>		<p>CODE IDENT. NO.</p> <p>DWG. NO. D 6600-2527</p> <p>REV. B</p>	<p>SCALE</p> <p>DR. NOT SCALE PRINT</p> <p>SHEET 1 OF 1</p>

SPECIFICATIONS UNLESS OTHERWISE NOTED:
 ANGULAR - 0
 DECIMAL - 2 PLACE
 DIMENSIONS - CONCENTRIC WITHIN AND THRU
 PILET DIMENSIONS - MAX
 THREADS - CLASS 2 BLANK IN ACCORDANCE WITH ITT SPEC 6300-1000

884	500P-0897
DRG.	NEXT ASST
APPLICATION	

This document contains proprietary information and is delivered upon the expressed condition that it will not be used directly or indirectly in any way detrimental to the interest of TPT Inc.

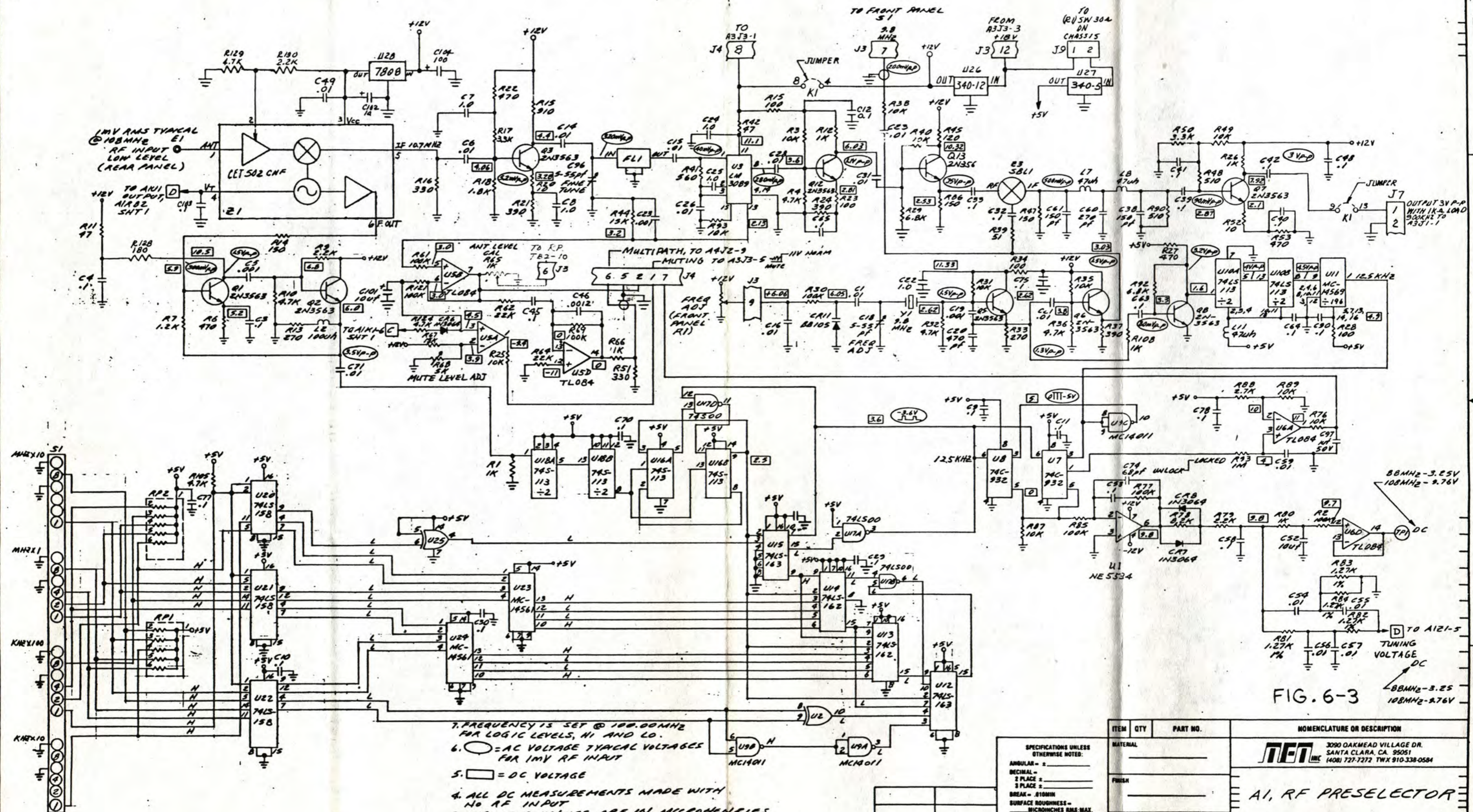

7. FREQUENCY IS SET @ 100.00MHZ FOR LOGIC LEVELS, HI AND LO.
6. ○ = AC VOLTAGE TYPICAL VOLTAGES FOR 1MV RF INPUT
5. □ = DC VOLTAGE
4. ALL DC MEASUREMENTS MADE WITH NO RF INPUT
3. INDUCTOR VALUES ARE IN MICROHENRIES
2. CAPACITOR VALUES ARE IN MIKRO FARADS
1. RESISTOR VALUES ARE IN OHMS UNLESS NOTED OTHERWISE SPECIFIED

SPECIFICATIONS UNLESS OTHERWISE NOTED:
 ANGULAR - 2
 DECIMAL - 2 PLACE ±
 3 PLACE ±
 BREAK - .010MIN
 SURFACE ROUGHNESS - MICRONS RMS: MAX.
 DIAMETERS - CONCENTRIC WITHIN .005 TIR.
 FILLET RADIUS - MAX
 THREADS - CLASS 2 MARK IN ACCORDANCE WITH SPC 5900-1000

884	6608-3646
MODEL	NEXT ASSY
APPLICATION	

ITEM	QTY	PART NO.	NOMENCLATURE OR DESCRIPTION
			MATERIAL
			FINISH
			DR. BY: ED ARAPT 2-1-88
			CK. BY: C.S. HO 5-7-88
			ENGR. V.S. LARSEN 5/6/88
			SCALE: NONE
			DO NOT SCALE PRINT
			SHEET 1 OF 2

3090 OAKMEAD VILLAGE DR. SANTA CLARA, CA. 95051 (408) 727-7272 TWX 910-338-0584

AI, RF PRESELECTOR

CODE IDENT NO. SIZE DRAWING NO. REV. D 6601-3646 A

This document contains proprietary information and is delivered upon the expressed condition that it will not be used directly or indirectly in any way detrimental to the interest of TPT Inc.

DWG. NO.		REV	DATE	APPD
-		SEE SHY 1		

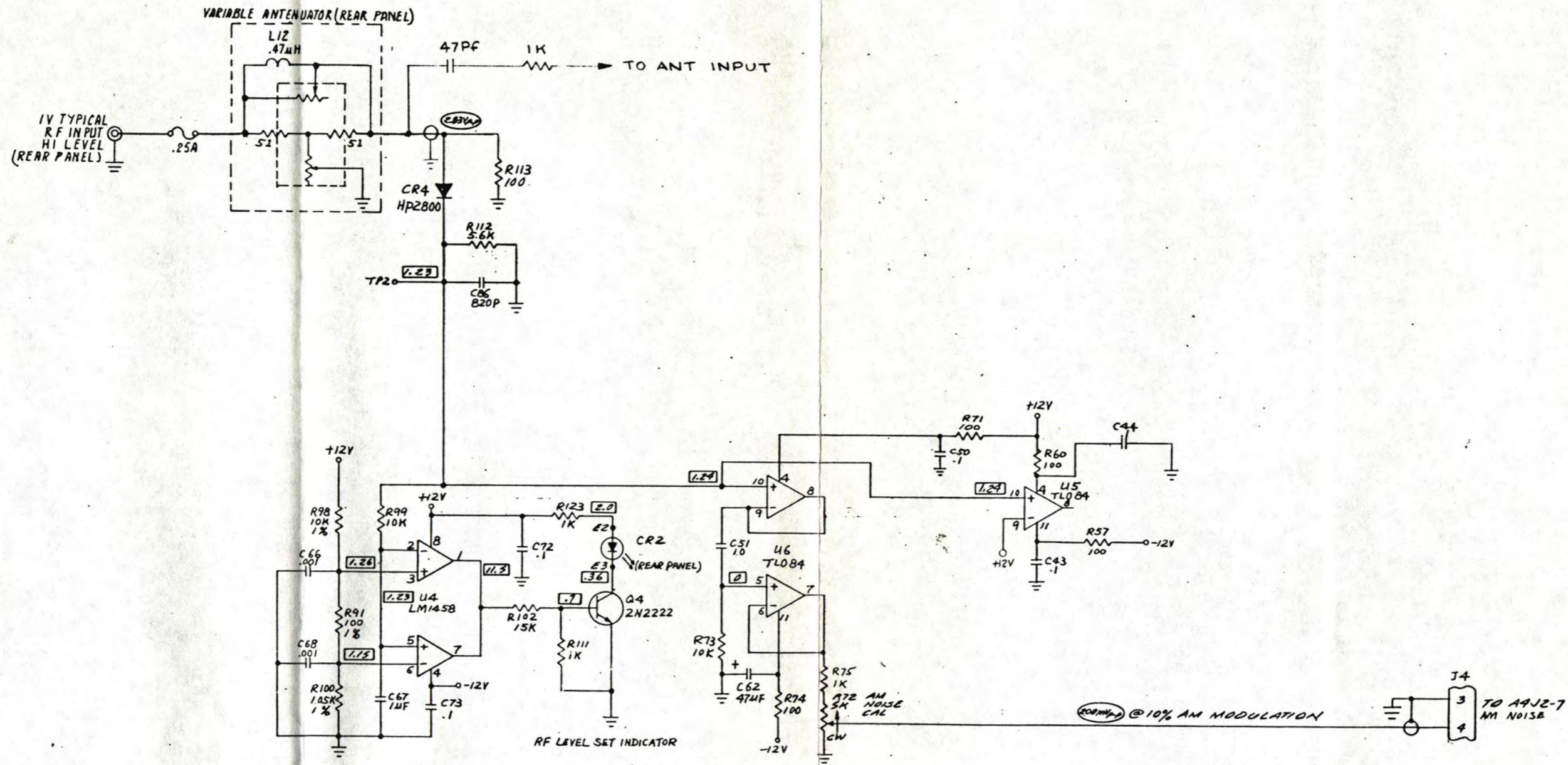

* CRYSTAL SELECTED UPON CUSTOMERS FREQUENCY

FIG. 6-3

884	
MODEL	NEXT ASSY
APPLICATION	

SPECIFICATIONS UNLESS OTHERWISE NOTED:
 ANGULAR - 2
 DECIMAL - 2
 2 PLACE 2
 3 PLACE 2
 BREAK - .010MIN
 SURFACE ROUGHNESS - MICRONS RMS MAX.
 DIMETERS - CONCENTRIC WITHIN .005 TIR.
 FILLET RADIUS - MAX
 THREADS - CLASS 2 MARK IN ACCORDANCE WITH TPT SPEC 8300-1000

ITEM	QTY	PART NO.	NOMENCLATURE OR DESCRIPTION
MATERIAL			3090 OAKMEAD VILLAGE DR. SANTA CLARA, CA. 95051 (408) 727-7272 TWX 910-338-0504
FINISH			
DR. BY ED KRAFT 2-1-88			A1. RF PRESELECTOR CODE IDENT NO. SIZE DRAWING NO. REV. ENGR. Y.S. LAW 5-7-88 D 6601-3646 A MFR. S.A. SCALE DO NOT SCALE PRINT SHEET 2 OF 2
CK. BY G.S. MA 5-7-88			
MFR. Y.S. LAW 5-7-88			
S.A.			

This document contains proprietary information and is controlled under the approved document that it will not be used directly or indirectly in any way other than to the interest of TRT Inc.

REVISIONS				
REV	DESCRIPTION	BY	DATE	AP
-	SEE SHEET 1			

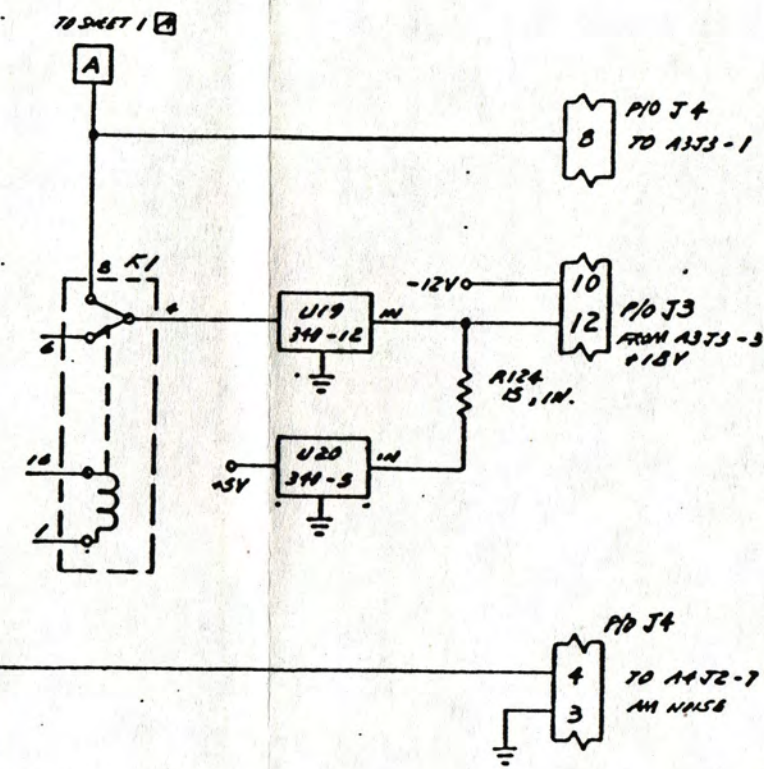
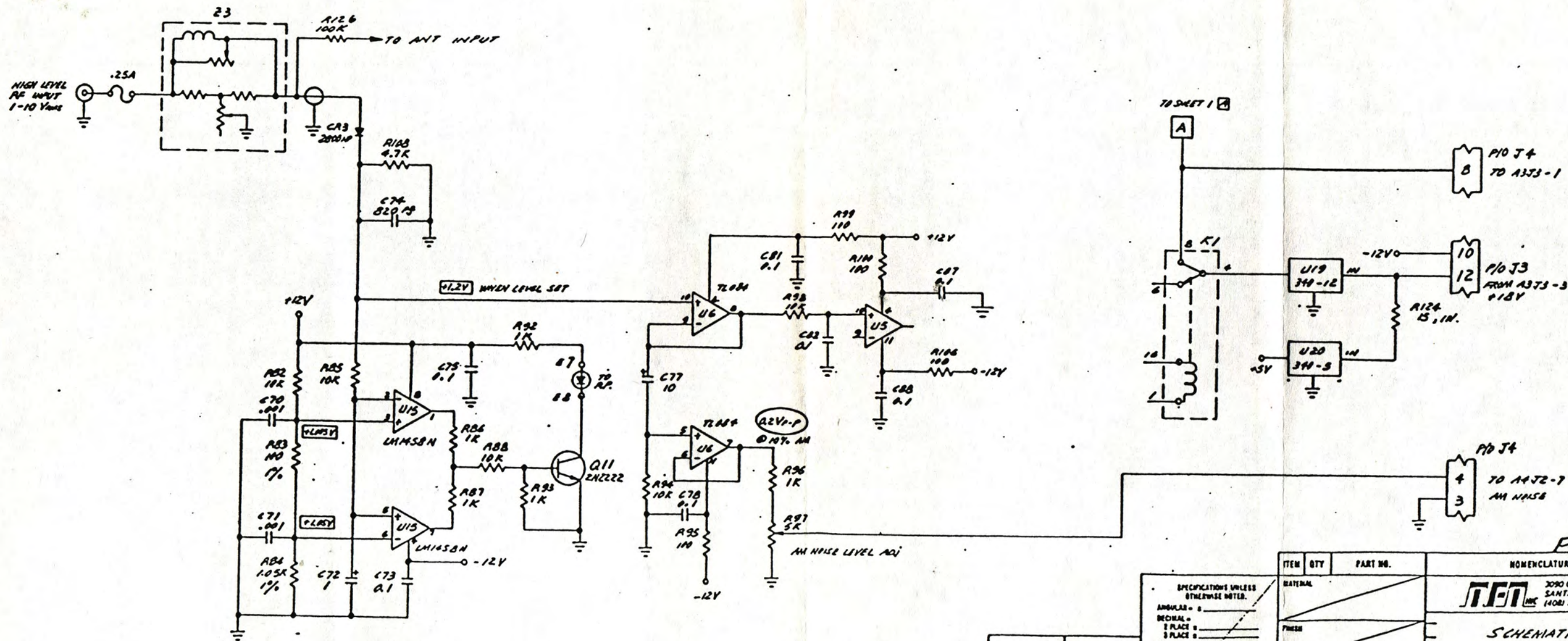

FIG. 6-3

ITEM	QTY	PART NO.	NOMENCLATURE OR DESCRIPTION
			3090 OAKHEAD VILLAGE DR. SANTA CLARA, CA 95051 (408) 737-7272 FAX 910-338-0584
			SCHEMATIC
			AI RF PRE-SELECTOR BD
			884
			CODE NEXT DR.
			SIZE D DRAWING NO. 6601-3713
			REV. A
			SCALE NONE IN NOT SCALE POINT SHEET 2 OF 2

884	6601-3713
DOOR	NEXT ASST
APPLICATION	

SPECIFICATIONS UNLESS OTHERWISE NOTED.
 ANGULAR - °
 DECIMAL - .
 2 PLACE -
 3 PLACE -
 4 PLACE -
 DIMEN - DIMENS
 SURFACE FINISH -
 HIC DIMENS AMS MAR.
 DIAMETERS - CONCENTRIC
 WITHIN .006 TOL.
 PULLEY RADII - MAX
 THREADS - CLASS 2
 UNLESS OTHERWISE SPECIFIED
 WITH E71 SPEC 5300-1000

This document contains proprietary information and is controlled upon the expressed condition that it will not be used directly or indirectly in any way detrimental to the interest of RFT Inc.

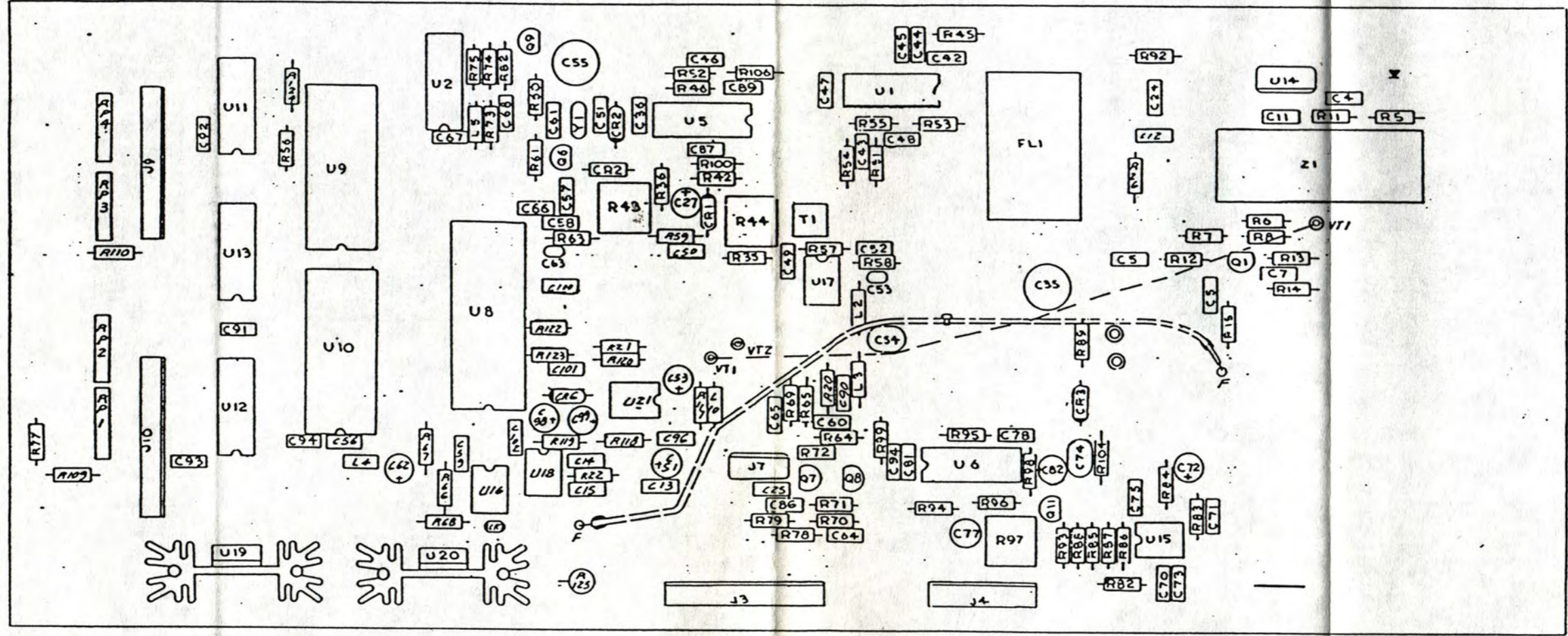

FIG. 6-4

3. FOR PCB SEE 1600-3403 (LATEST REV.)
 2. FOR SCHEMATIC SEE 6601-3646 (LATEST REV.)
 1. FOR MATL LIST SEE 660B-3646 (LATEST REV.)
- NOTES: UNLESS OTHERWISE SPECIFIED

STEAM POWERED RADIO.COM

ITEM	QTY	PART NO.	NOMENCLATURE OR DESCRIPTION	
MATERIAL			<p>RFI 3090 DAKMEAD VILLAGE DR. SANTA CLARA, CA. 95051 14081 737-7373 TWX 910-328-0584</p>	
FINISH			<p>P.C. BOARD ASSEMBLY - AI RF PRE-SELECTOR</p>	
DR. BY <i>VED KRAFT</i>			DATE	2-1-88
CL. BY			CODE IDENT. NO.	SIZE
ENGR.			DRAWING NO.	660B-3646
MFG.			REV.	A
S/A			SCALE	2/1
			DO NOT SCALE PRINT	SHEET 1 OF 1

SPECIFICATIONS UNLESS OTHERWISE NOTED:
 ANGULAR - \pm --
 DECIMAL - 3 PLACE \pm --
 BREAK - .010000
 SURFACE ROUGHNESS - μ INCHES MAX.
 DIAHETALS - CONCENTRIC WITHIN .005 TH.
 PILET RADIUS - \pm MAX
 THREADS - CLASS 2 MAKE IN ACCORDANCE WITH RFT SPEC 6388-1008

MODEL	NEXT ASSY	APPLICATION
884	5102-	

Table with 5 columns: CKT REF, DESCRIPTION, QTY, TFT STOCK NO. Rows include components like CAP CER DISC 1MFD, CAP MICA 56 PF, CAP MICA 10 PF, etc.

Table with 5 columns: CKT REF, DESCRIPTION, QTY, TFT STOCK NO. Rows include components like CAP MICA 1000PF 500V, CAP MICA 470PF 500V, CAP CER 0.1MF CK05BX K, etc.

Table with 5 columns: CKT REF, DESCRIPTION, QTY, TFT STOCK NO. Rows include components like CAP ELECT 10 MFD 25V VERT HT, CAP ELECT VT HT 100UF (NO SUB.), CAP CER 0.1MF CK05BX K, etc.

Table with 5 columns: CKT REF, DESCRIPTION, QTY, TFT STOCK NO. Rows include components like PCB A3 FM DEMODULATOR, TRANS 2N4275, TRANS 2N4121, etc.

Table with 5 columns: CKT REF, DESCRIPTION, QTY, TFT STOCK NO. Rows include components like RES CAR FILM 1/4W 5% 10K, RES CAR COMP 1/4W 5% 3.3K, RES CAR COMP 1/4W 5% 1.5K, etc.

Table with 5 columns: CKT REF, DESCRIPTION, QTY, TFT STOCK NO. Rows include components like RES CAR COMP 1/4W 5% 7.5K, RES CAR COMP 1/4W 5% 5.6K, RES MT FLM 1/8W 1% 10K, etc.

Table with 5 columns: CKT REF, DESCRIPTION, QTY, TFT STOCK NO. Rows include components like TY-WRAP NYLON .14W x 5 5/8 LG, IC LM361J HI SPEED DIFF COMPARATOR, I/C 74221 DUAL ONE SHOT, etc.

Table with 5 columns: CKT REF, DESCRIPTION, QTY, TFT STOCK NO. Rows include components like SOCKET, 1/C 8 PIN, SOCKET, 1/C 16 PIN, SOCKET 1/C 14PIN, etc.

This document contains proprietary information and is intended for use only by the recipient. It is to be used directly or indirectly in any way that may result in the disclosure of TTT info.

REV	DESCRIPTION	BY	DATE	APP
1	PILOT RUN RELEASE	AN	3-13-66	
A	PAOD. RELEASE 144 110 1750	AC	1-3-67	

ADD JUMPER WIRE ON CIRCUIT SIDE OF PCB FROM U11 PIN 1 TO EXISTING PAD (P54) ON PCB AS SHOWN

SOLDER TO GROUNDING LEAD

JUMPER WIRE

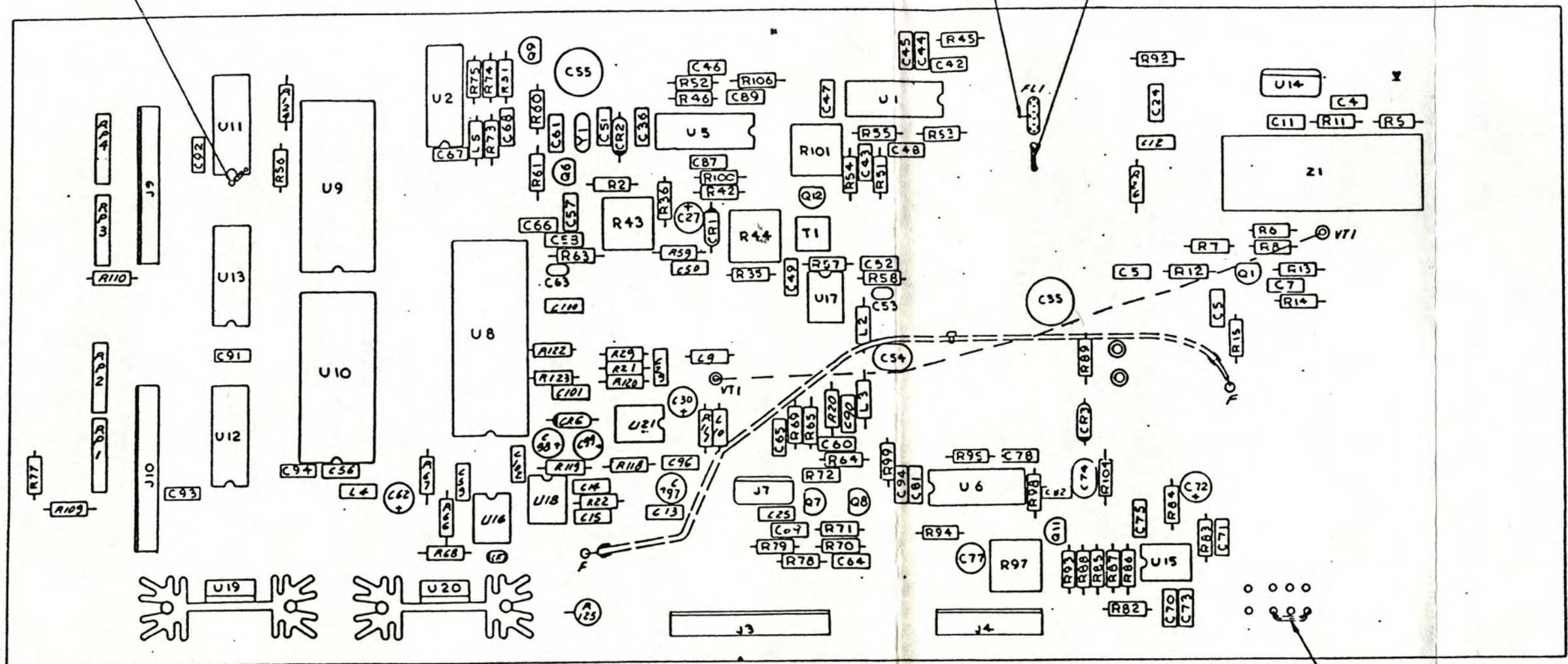

INSTALL JUMPER WIRE WITH SLEEVE AS SHOWN

2. SCHEMATIC PNG 6601-3713
 1. PCB NO. 1600-3672
 NOTES:

FIG. 6-4

884	5102-3548
MODEL	NEXT ASSY
APPLICATION	

SPECIFICATIONS UNLESS OTHERWISE NOTED:
 ANGULAR - 0
 DECIMAL - 0.001
 2 PLACE - 0.01
 3 PLACE - 0.001
 BREAK - 210MM
 SURFACE FINISHES -
 --- MICROFINISHES AND MAX.
 MANIFOLDERS - CONCENTRIC
 WITHIN .001 TOL.
 FILLET RADII - MAX
 THREADS - CLASS 2
 MADE IN ACCORDANCE
 WITH TTT SPEC 1300-1000

ITEM	QTY	PART NO.	NOMENCLATURE OR DESCRIPTION	
MATERIAL			3090 OAKMEAD VILLAGE DR. SANTA CLARA, CA. 95051 (408) 727-7272 TWX 910-338-0504	
FINISH				
DR. BY: <i>ELC</i>			DATE: 1-3-67	AIR PRESELECT 884
CK BY:			CODE IDENT. NO.	
MFR.			SIZE: D	DRAWING NO.: 6608-3713
S.A.			SCALE: 2:1	DO NOT SCALE PRINT SHEET 1 OF 1

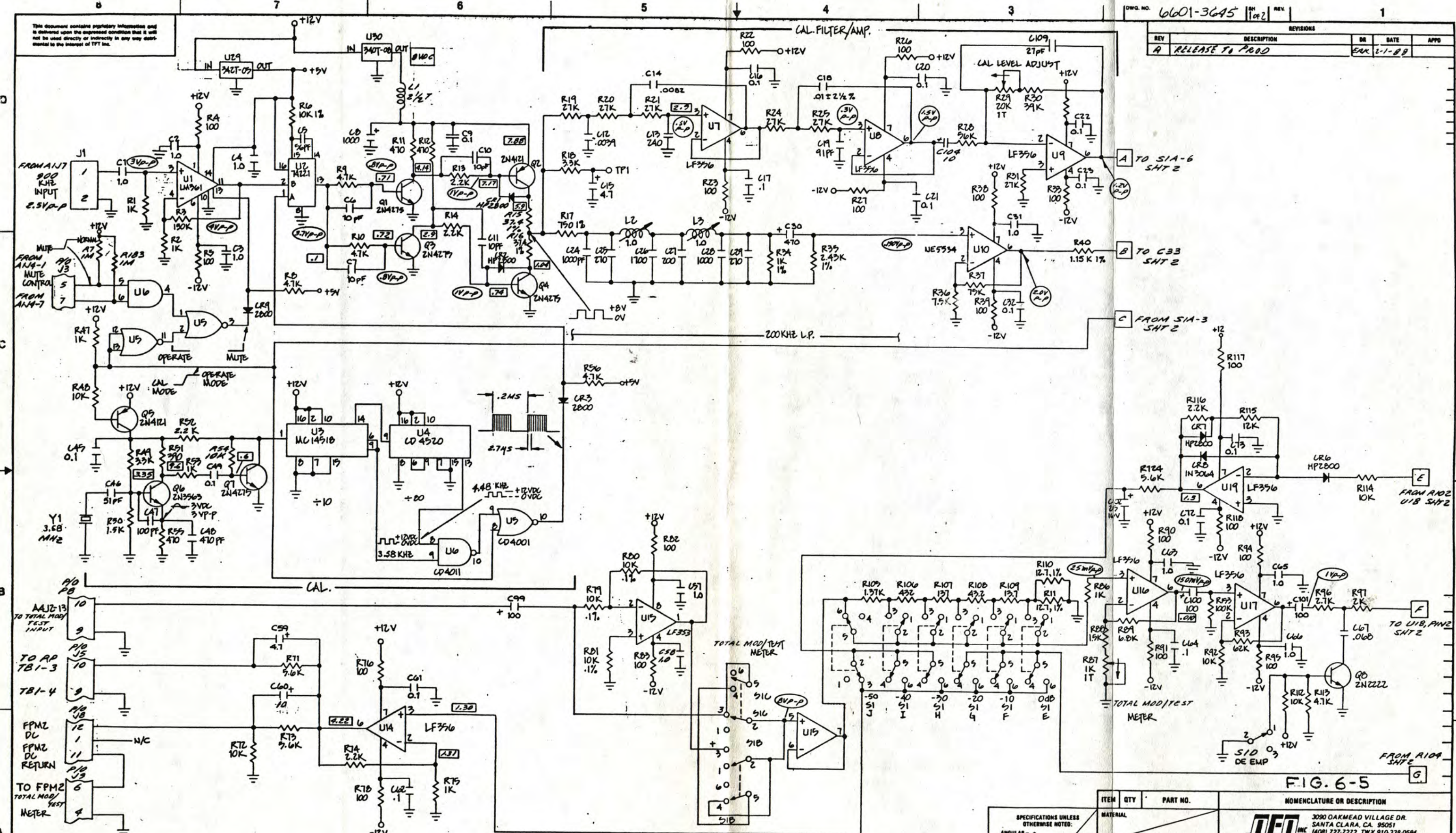

- NOTES: UNLESS OTHERWISE SPECIFIED:
1. RESISTOR VALUES ARE IN OHMS, $\frac{1}{4}$ W. 5%.
 2. CAPACITOR VALUES ARE IN MICROFARADS.
 3. INDUCTOR VALUES ARE IN MICROHENRIES.
 4. PCB 1600-3405 SCHEMATIC 6601-3645 MATL. LIST 6600-3645
 5. = DC VOLTAGE
 6. = AC VOLTAGE TYPICAL VOLTAGES FOR 100% MODULATION
 7. = CALIBRATE READING TAKEN IN CALIBRATE MODE.

ITEM	QTY	PART NO.	NOMENCLATURE OR DESCRIPTION
MATERIAL			3090 OAKMEAD VILLAGE DR. SANTA CLARA, CA. 95051 (408) 727-7272 TWX 910-338-0584
FINISH			
DR. BY: <i>Ed Knopf</i> 3-15-89			A3, FM DEMODULATOR CODE IDENT NO. SIZE DRAWING NO. REV. D 6601-3645 A
CK. BY: <i>RIL</i> 3-16-89			
ENGR: <i>Y. S. LAW</i> 3-16-89			SCALE N/A DO NOT SCALE PRINT SHEET OF 2
APP. BY: <i>[Signature]</i>			

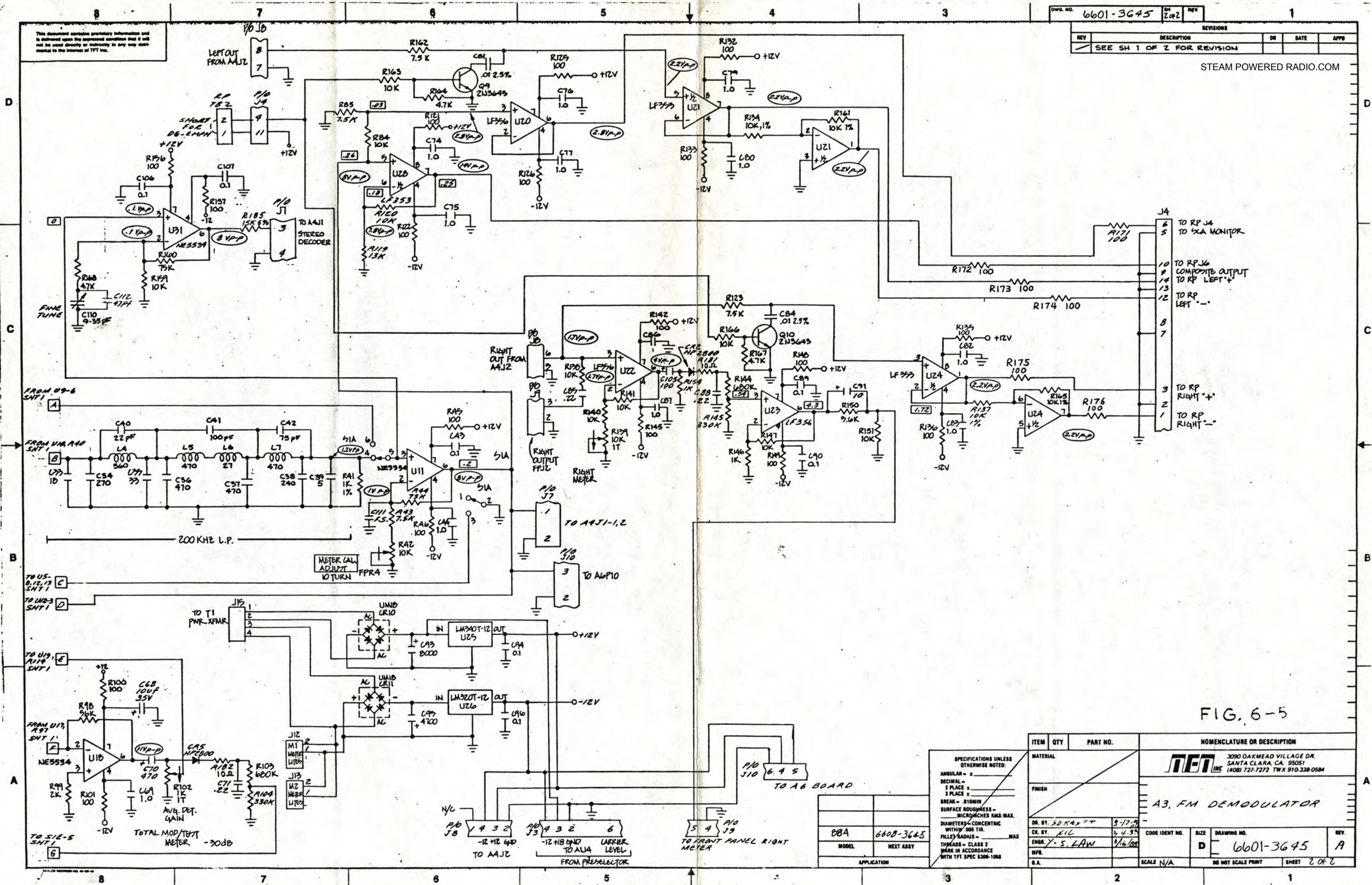

FIG. 6-5

ITEM	QTY	PART NO.	NOMENCLATURE OR DESCRIPTION
			<p>NET 3090 OAKMEAD VILLAGE DR. SANTA CLARA, CA. 95051 (408) 727-7272 TWX 910-338-0584</p>
			A3, FM DEMODULATOR
DR. BY: SD K... T		9-17-95	CODE IDENT NO.
ENGR. Y. S. LAW		3-4-95	SIZE
MFR.		3/16/95	DRAWING NO.
O.A.			6601-3645
			REV. A
			SCALE N/A
			DO NOT SCALE PRINT
			SHEET 2 OF 2

SPECIFICATIONS UNLESS OTHERWISE NOTED:
 ANGULAR - 2
 DECIMAL - 2 PLACE
 BREAK - 0.10MM SURFACE ROUGHNESS - MICROCHES RMS-MAX. DIAMETERS - CONCENTRIC WITHIN .000 TIR. FILLET RADIUS - MAX. THREADS - CLASS 2 MARK IN ACCORDANCE WITH TFI SPEC 8300-1068

MODEL	6601-3645
APPLICATION	NEXT ASSY

This document contains proprietary information and is intended for use only by the recipient to whom it is addressed. It is not to be used, copied, or otherwise disseminated to the Internet or 1971 Inc.

REV	DESCRIPTION	BY	DATE	APP
1	SEE SH 1 OF 2 FOR REVISION			

STEAM POWERED RADIO.COM

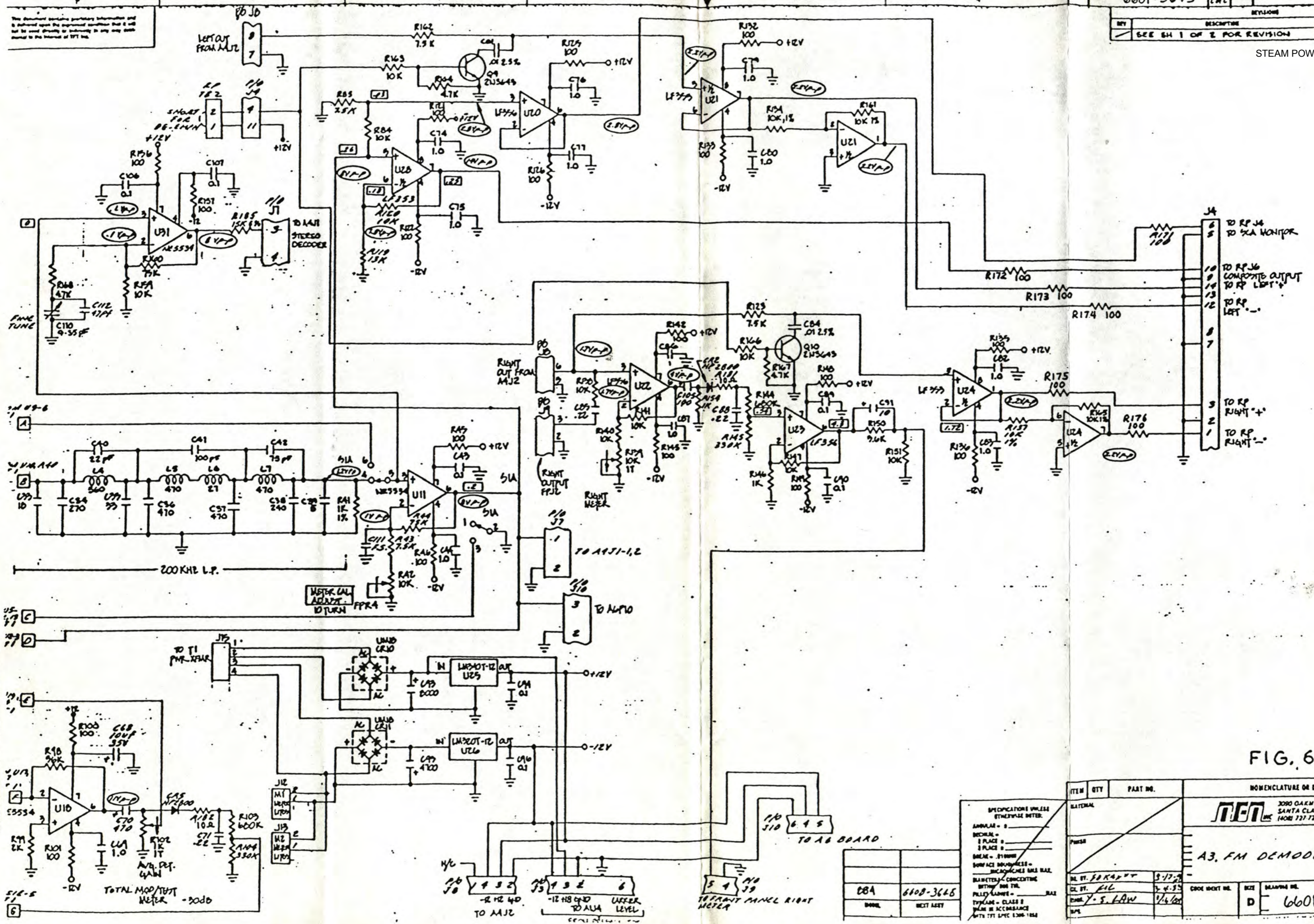
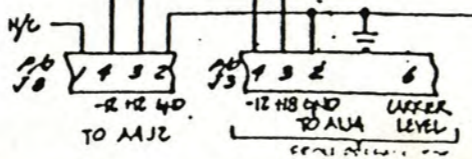
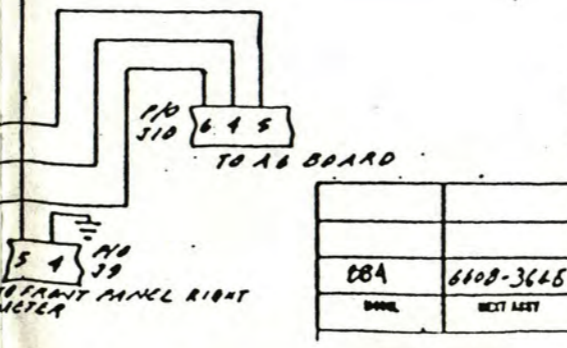

FIG. 6-5

ITEM	QTY	PART NO.	NOMENCLATURE OR DESCRIPTION
INTERNAL			3090 OAKMEAD VILLAGE DR. SANTA CLARA, CA. 95051 (408) 737-7373 FAX 810-338-0584
PANEL			33. FM DEMODULATOR
DL ST.	50	5-17-79	
CL ST.	216	7-4-85	
CHKD BY	J.S. LAW	1/4/88	
TYPE	CLASS B		
PLAN	IN ACCORDANCE WITH ITC SPEC 1.306-118A		
CODE IDENT. NO.	D	6601-3645	REV. B

SPECIFICATIONS UNLESS OTHERWISE NOTED:
 APPROX. = 0
 DECIMAL = 1 PLACE
 1 PLACE = 2
 2 PLACE = 3
 BREAK = 100MM
 SURFACE MOUNTING = MICROSCOPIC BALL MOUNT
 BRACKETED - CONCENTRIC
 WITHIN THE
 FILLED AREA =
 TYPICALLY - CLASS B
 PLAN IN ACCORDANCE WITH ITC SPEC 1.306-118A

Q84	6608-3645	
Q84	6608-3645	



TOTAL MOD/DBT METER - 30dB

1. The manufacturer's name, part number, and value are to be indicated on the component and are to be read directly or indirectly in any way deemed desirable by the user of the drawing.

REV	DESCRIPTION	BY	DATE	APP
A	RELEASE TO PROD	SKC	1-1-88	
B	SHT 2 OF 2, R181 WAS 1065-0100 PER ELO 1750	AC	1/4/89	

STEAM POWERED RADIO.COM

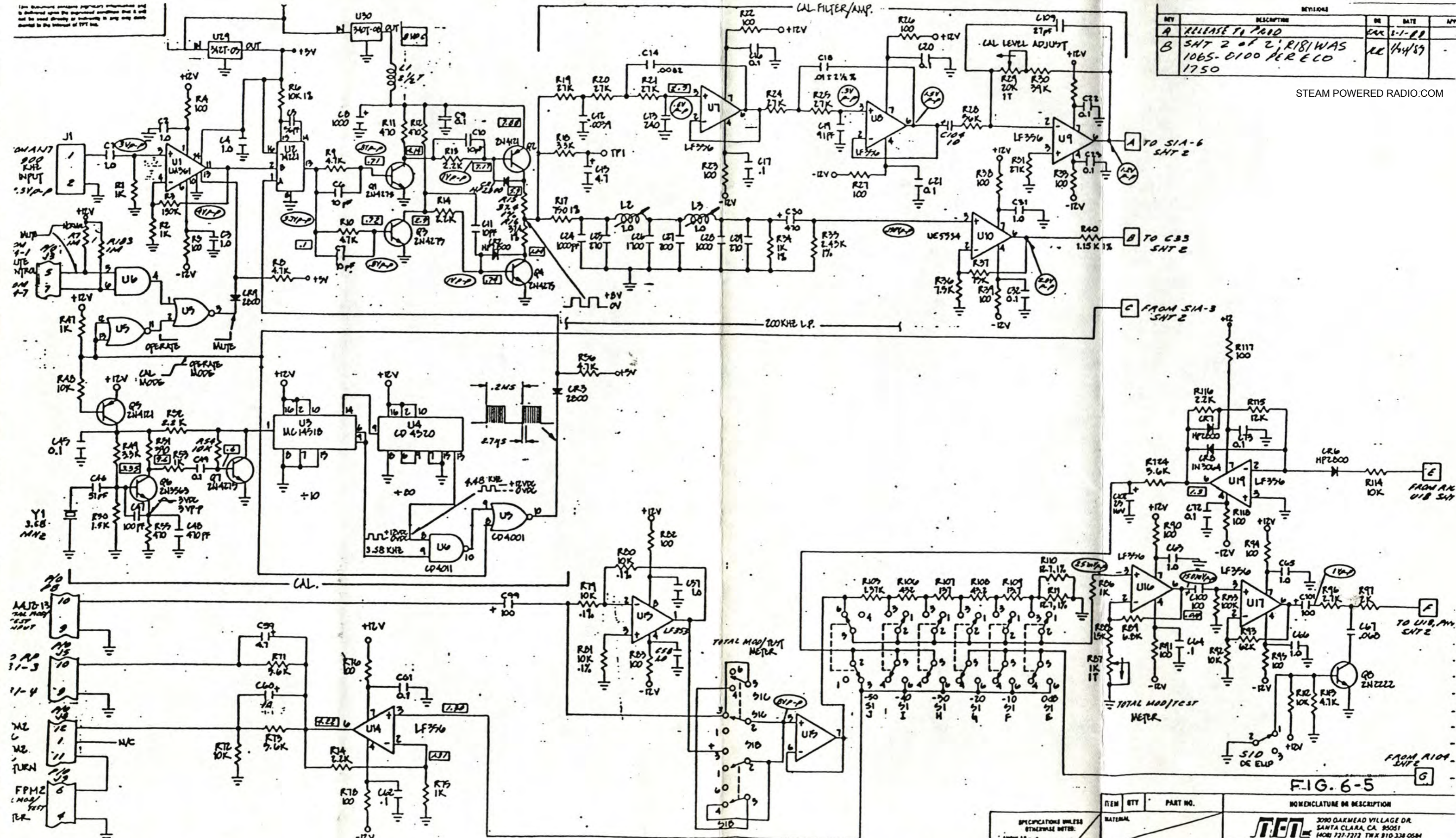

- NOTES: UNLESS OTHERWISE SPECIFIED**
1. RESISTOR VALUES ARE IN OHMS, $\times 10^3$, $\times 10^4$, $\times 10^5$.
 2. CAPACITOR VALUES ARE IN MICROFARADS.
 3. INDUCTOR VALUES ARE IN MICROHENRIES.
 4. PLO 1600-3405
SCHEMATIC 6601-3645
WATERLOO 6600-3645
 5. = DC VOLTAGE
 6. = AC VOLTAGE TYPICAL VOLTAGES FOR 100% MODULATION
 7. = CALIBRATE READING TAKEN IN CALIBRATE MODE.

884	6600-3145
ISSUED	REVISION

SPECIFICATIONS UNLESS OTHERWISE NOTED:
 ANGULAR - °
 DECIMAL - 2 PLACE
 BREAK - STUBS
 SURFACE MOUNTS - MICRODOTS
 DIMETERS - CONCISE WITHIN DIM TOL.
 FILLET RADIUS - MAX
 THICKNESS - CLASS 1
 MADE IN ACCORDANCE WITH IYI SPEC 1396-1988

ITEM	QTY	PART NO.	NOMENCLATURE OR DESCRIPTION
MATERIAL			3090 OAKMEAD VILLAGE DR SANTA CLARA, CA 95051 MOBILE 727-7272 FAX 910-338-0584
A3, FM DEMODULATOR			
DR. BY	DATE	SCALE	DRAWING NO.
CHK. BY			
APP. BY			
DATE			
SCALE: 1/4"			NO. OF SHEETS: 2
DRAWING NO. 6601-3645			REV. B

FIG. 6-5

This document contains proprietary information and is delivered upon the expressed condition that it will not be used directly or indirectly in any way detrimental to the interest of TFT Inc.

REVISIONS				
REV	DESCRIPTION	DR	DATE	APPD
A	RELEASED TO PROD	BRK	2-1-89	

STEAM POWERED RADIO.COM

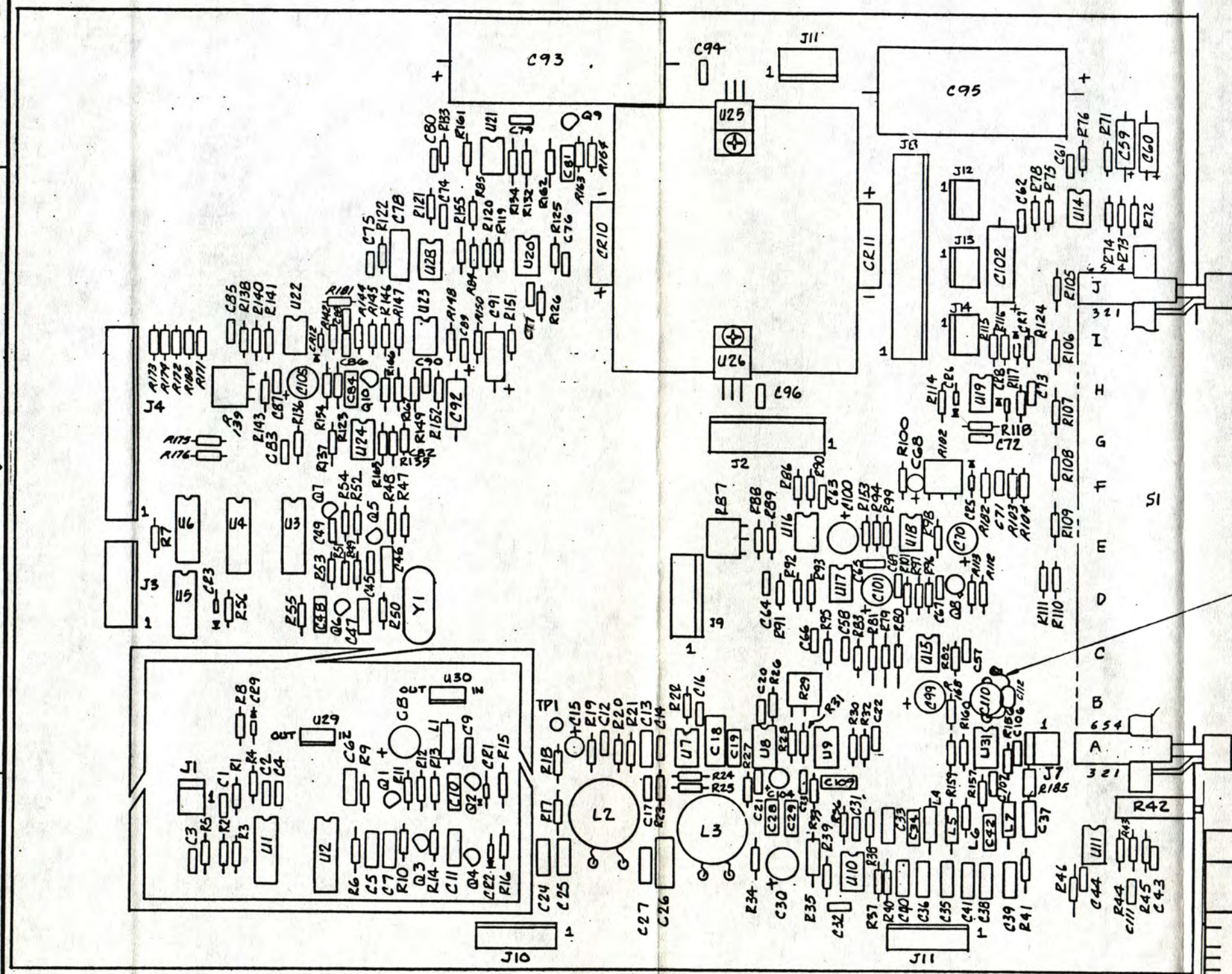

SOLDER ONE LEAD OF C112 TO GROUND AS SHOWN

FIG. 6-6

NOTES: UNLESS OTHERWISE SPECIFIED
 1. REF; SCHEMATIC 6601-3645
 PCB ASSY. P/6608-3645
 PCB FAB 1600-3405

MODEL	884	5102-3548
NEXT ASSY		
APPLICATION		

DIAMETERS - CONCENTRIC WITHIN .005 TIR.
 FILLET RADIUS - MAX
 THREADS - CLASS 2 MARK IN ACCORDANCE WITH TFT SPEC 8300-1008

DR. BY	ED KRAFT	2-1-89
CK. BY	KIK	2-16-89
ENGR.	Y. S. LAU	3/8/89
MFG.		
D.A.		

NOMENCLATURE OR DESCRIPTION
NET 3090 OAKMEAD VILLAGE DR.
 SANTA CLARA, CA. 95051
 (408) 727-7272 TWX 910-338-0584

PCB ASSEMBLY-
 A3 FM DEMODULATOR

CODE IDENT NO.	SIZE	DRAWING NO.	REV.
	C	6608-3645	A
SCALE FULL	DO NOT SCALE PRINT	SHEET 1 OF 1	

This document contains proprietary information and is delivered upon the expressed condition that it will not be used directly or indirectly in any way detrimental to the interest of TTT Inc.

REVISIONS				
REV	DESCRIPTION	BY	DATE	APPD
A	RELEASED TO PROD	AK	3-1-89	
B	REVISED PER ECO 1750	AK	1-24-89	

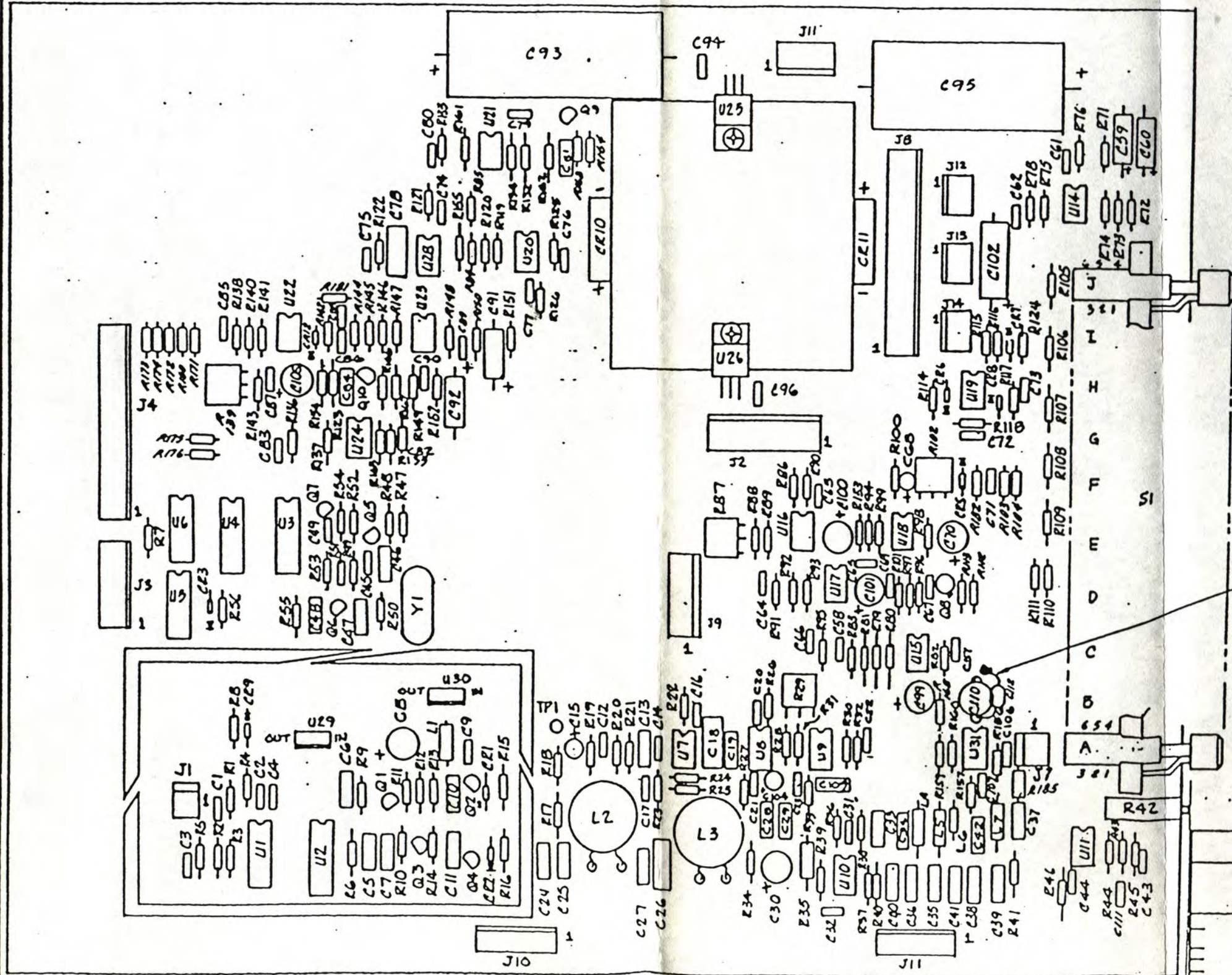

NOTES: UNLESS OTHERWISE SPECIFIED
 1. RGT; SCHEMATIC 6601-3645
 PCB ASSY. #16608-3645
 PCB FAB 1600-3405

884	5102-354B
MODEL	WEST ASST

DR. BY ED KRAFT
 CK. BY AK
 ENGR. Y. S. LAU
 W/R

DATE	21-88
REV	3-1-89
DATE	1/1/89

SCALE	FULL
CODE BOOK NO.	
DATE	
DRAWING NO.	6608-3645
REV.	B

CKT REF	DESCRIPTION	QTY	TFT STOCK NO.
C001	CAP CER DISC 1MFD	1	1005-0001
C002	CAP CER DISC 1MFD	1	1005-0001
C003	CAP CER DISC 1MFD	1	1005-0001
C004	CAP CER DISC 1MFD	1	1005-0001
C005	CAP MICA 56 PF	1	1001-0560
C006	CAP MICA 10 PF	1	1001-0100
C007	CAP MICA 10 PF	1	1001-0100
C008	CAP ELEC 1000MF 16V VERT MT	1	1010-0012
C009	CAP CER 0.1MF CK05BX K	1	1015-0001
C010	CAP MICA 10 PF	1	1001-0100
C011	CAP MICA 10 PF	1	1001-0100
C012	CAP CER .0039MF CK05 BX 392K	1	1015-0039
C013	CAP MICA 240 PF	1	1001-0241
C014	CAP CER .0082MF CK0 5BX	1	1015-0082
C015	CAP ELECT 10MF 10V RADIAL	1	1010-0011
C016	CAP CER 0.1MF CK05BX K	1	1015-0001
C017	CAP CER 0.1MF CK05BX K	1	1015-0001
C018	CAP MET POLY .01UF +21/2	1	1006-0002
C019	CAP MICA 91 PF 500V	1	1001-0910
C020	CAP CER 0.1MF CK05BX K	1	1015-0001
C021	CAP CER 0.1MF CK05BX K	1	1015-0001
C022	CAP CER 0.1MF CK05BX K	1	1015-0001
C023	CAP CER 0.1MF CK05BX K	1	1015-0001
C024	CAP MICA 1000PF 500V	1	1001-0102
C025	CAP MICA 270 PF	1	1001-0271
C026	CAP MICA 1700 PF	1	1001-0172
C027	CAP MICA 200 PF	1	1001-0201
C028	CAP MICA 1000PF 500V	1	1001-0102
C029	CAP MICA 270 PF	1	1001-0271
C030	CAP ELEC 470MF 25V VERT HNT	1	1010-0045
C031	CAP CER DISC 1MFD	1	1005-0001
C032	CAP CER DISC 1MFD	1	1005-0001
C033	CAP MICA 18 PF	1	1001-0180
C034	CAP MICA 270 PF	1	1001-0271
C035	CAP MICA 33PF 500V	1	1001-0330
C036	CAP MICA 470PF 500V	1	1001-0471
C037	CAP MICA 470PF 500V	1	1001-0471
C038	CAP MICA 240 PF	1	1001-0241
C039	CAP MICA 5.0PF 500V	1	1001-0050
C040	CAP MICA 22 PF	1	1001-0220
C041	CAP MICA 100 PF	1	1001-0101
C042	CAP MICA 75 PF	1	1001-0750
C043	CAP CER DISC 1MFD	1	1005-0001
C044	CAP CER DISC 1MFD	1	1005-0001
C045	CAP CER 0.1MF CK05BX K	1	1015-0001
C046	CAP MICA 51 PF	1	1001-0510

CKT REF	DESCRIPTION	QTY	TFT STOCK NO.
C047	CAP MICA 1000PF 500V	1	1001-0102
C048	CAP MICA 470PF 500V	1	1001-0471
C049	CAP CER 0.1MF CK05BX K	1	1015-0001
C050	CAP CER DISC 1MFD	1	1005-0001
C051	CAP CER DISC 1MFD	1	1005-0001
C052	CAP CER DISC 1MFD	1	1005-0001
C053	CAP TAN 4.7MFD 35V 10%	1	1008-0047
C054	CAP TAN 10MFD 20V 10%	1	1008-0101
C055	CAP CER 0.1MF CK05BX K	1	1015-0001
C056	CAP CER 0.1MF CK05BX K	1	1015-0001
C057	CAP CER DISC 1MFD	1	1005-0001
C058	CAP CER DISC 1MFD	1	1005-0001
C059	CAP CER DISC 1MFD	1	1005-0001
C060	CAP CER DISC 1MFD	1	1005-0001
C061	CAP CER 0.1MF CK05BX K	1	1015-0001
C062	CAP CER 0.1MF CK05BX K	1	1015-0001
C063	CAP CER DISC 1MFD	1	1005-0001
C064	CAP CER DISC 1MFD	1	1005-0001
C065	CAP CER DISC 1MFD	1	1005-0001
C066	CAP CER DISC 1MFD	1	1005-0001
C067	CAP CER .068MF CK05BX K	1	1015-0013
C068	CAP ELECT 10 MFD 25V VERT MT	1	1010-0099
C069	CAP CER DISC 1MFD	1	1005-0001
C070	CAP ELEC 470MF 25V VERT HNT	1	1010-0045
C071	CAP CER .22MF CK06BX K	1	1015-0003
C072	CAP CER 0.1MF CK05BX K	1	1015-0001
C073	CAP CER 0.1MF CK05BX K	1	1015-0001
C074	CAP CER DISC 1MFD	1	1005-0001
C075	CAP CER DISC 1MFD	1	1005-0001
C076	CAP CER DISC 1MFD	1	1005-0001
C077	CAP CER DISC 1MFD	1	1005-0001
C078	CAP CER DISC 1MFD	1	1005-0001
C079	CAP CER DISC 1MFD	1	1005-0001
C080	CAP CER DISC 1MFD	1	1005-0001
C081	CAP MET POLY .01UF +21/2	1	1006-0002
C082	CAP CER DISC 1MFD	1	1005-0001
C083	CAP CER DISC 1MFD	1	1005-0001
C084	CAP MET POLY .01UF +21/2	1	1006-0002
C085	CAP CER .22MF CK06BX K	1	1015-0003
C086	CAP CER DISC 1MFD	1	1005-0001
C087	CAP CER DISC 1MFD	1	1005-0001
C088	CAP CER .22MF CK06BX K	1	1015-0003
C089	CAP CER 0.1MF CK05BX K	1	1015-0001
C090	CAP CER 0.1MF CK05BX K	1	1015-0001
C091	CAP TAN 10MFD 20V 10%	1	1008-0101
C092	CAP TAN 4.7MFD 35V 10%	1	1008-0047
C093	CAP ELECT 8000MFD 25V	1	1010-8000
C094	CAP CER 0.1MF CK05BX K	1	1015-0001
C095	CAP ELECT 470MFD 35V	1	1010-0472
C096	CAP CER 0.1MF CK05BX K	1	1015-0001
C099	CAP ELECT VT MT 100UF (NO SUB.)	1	1010-0110
C100	CAP ELECT VT MT 100UF (NO SUB.)	1	1010-0110
C101	CAP ELECT VT MT 100UF (NO SUB.)	1	1010-0110
C102	CAP ELECT 25MFD 6V	1	1010-0250

CKT REF	DESCRIPTION	QTY	TFT STOCK NO.
C104	CAP ELECT 10 MFD 25V VERT MT	1	1010-0099
C105	CAP ELECT VT MT 100UF (NO SUB.)	1	1010-0110
C106	CAP CER 0.1MF CK05BX K	1	1015-0001
C107	CAP CER 0.1MF CK05BX K	1	1015-0001
C108	CAP MICA 27PF 500V	1	1001-0270
C109	CAP VAR 10-40PF	1	1012-1040
C110	CAP MICA 47 PF	1	1001-0470
C111	DIO HP5082 HOT CARRIER	1	1282-2800
C112	DIO HP5082 HOT CARRIER	1	1282-2800
CR01	DIO HP5082 HOT CARRIER	1	1282-2800
CR02	DIO HP5082 HOT CARRIER	1	1282-2800
CR03	DIO HP5082 HOT CARRIER	1	1282-2800
CR04	DIO HP5082 HOT CARRIER	1	1282-2800
CR05	DIO HP5082 HOT CARRIER	1	1282-2800
CR06	DIO HP5082 HOT CARRIER	1	1282-2800
CR07	DIO HP5082 HOT CARRIER	1	1282-2800
CR08	DIO IN3064	1	1282-2800
CR09	DIO HP5082 HOT CARRIER	1	1281-3064
CR10	MDS970A2 BRIDGE RECTIFIER	1	1284-9702
CR11	MDS970A2 BRIDGE RECTIFIER	1	1284-9702
CR12	DIO HP5082 HOT CARRIER	1	1282-2800
HS01	HEAT SINK EBS	1	2010-1401
INS1	INSULATOR MICA T0220 PKG	1	2140-0103
INS2	INSULATOR MICA T0220 PKG	1	2140-0103
J001	PLUG, LOCKING 2 PIN	1	2250-6002
J002	PLUG LOCK 8 PIN MOLEX	1	2250-6503
J003	PLUG LOCK MOLEX 7 PIN	1	2250-6503
J004	CONN 14 PIN MOLEX	1	2250-6503
J005	PLUG, 10 PIN	1	2250-6014
J006	PLUG LOCK 8 PIN MOLEX	1	2250-6510
J007	PLUG, 4 PIN	1	2250-6506
J008	CONN 12 PIN MOLEX	1	2250-6012
J009	PLUG LOCK MOLEX 6 PIN	1	2250-6506
J010	PLUG LOCK MOLEX 6 PIN	1	2250-6506
J011	PLUG LOCK MOLEX 6 PIN	1	2250-6506
J012	PLUG, LOCKING 3 PIN	1	2250-6003
J013	PLUG, LOCKING 3 PIN	1	2250-6003
J014	PLUG, LOCKING 3 PIN	1	2250-6003
J015	PLUG LOCK MOLEX 4 PIN	1	2250-6504
L001	CHOKO RF 2 1/2 TURNS	1	1530-0025
L002	M/L IND VAC 76T	1	1577-0920
L003	M/L IND VAC 76T	1	1577-0920
L004	CHOKO 560 UH	1	1530-0561
L005	CHOKO R F 470 UH	1	1530-0471
L006	CHOKO R F 27 UH	1	1530-0270
L007	CHOKO R F 470 UH	1	1530-0471
N001	NUT 4-40 SELF LOCK W/NYLON INSERT	1	2111-0002
N002	NUT 4-40 SELF LOCK W/NYLON INSERT	1	2111-0002
N003	NYLON WASHER PWR TRANSISTOR	1	2140-0137

CKT REF	DESCRIPTION	QTY	TFT STOCK NO.
NYW2	NYLON WASHER PWR TRANSISTOR	1	2140-0137
PCB01	PCB A3 FM DEMODULATOR	1	1600-3405
Q001	TRANS 2N4275	1	1271-4275
Q002	TRANS 2N4121	1	1271-4121
Q003	TRANS 2N4275	1	1271-4275
Q004	TRANS 2N4275	1	1271-4275
Q005	TRANS 2N4121	1	1271-4121
Q006	TRANS 2N3563	1	1271-3563
Q007	TRANS 2N4275	1	1271-4275
Q008	TRANS 2N2222	1	1271-2222
Q009	TRANS 2N3643	1	1271-3643
Q010	TRANS 2N3643	1	1271-3643
R001	RES CAR FILM 1/4W 5% 1K	1	1065-1001
R002	RES CAR FILM 1/4W 5% 1K	1	1065-1001
R003	RES CAR FILM 1/4W 5% 150K	1	1065-1503
R004	RES CAR COMP 1/4W 5% 100	1	1065-0100
R005	RES CAR COMP 1/4W 5% 100	1	1065-0100
R006	RES MT FLM 1/8W 1% 10K	1	1061-1002
R007	RES CAR FILM 1/4W 5% 1M	2	1065-1004
R008	RES CAR FILM 4.7K 1/4W 5%	1	1065-4701
R009	RES CAR FILM 4.7K 1/4W 5%	1	1065-4701
R010	RES CAR FILM 4.7K 1/4W 5%	1	1065-4701
R011	RES CAR FILM 1/4W 5% 470 OHM	1	1065-0470
R012	RES CAR FILM 1/4W 5% 470 OHM	1	1065-0470
R013	RES CAR FILM 1/4W 5% 2.2K	1	1065-2201
R014	RES CAR FILM 1/4W 5% 2.2K	1	1065-2201
R015	RES M.F. 37.4 1% 1/8W	1	1061-0037
R016	RES M.F. 37.4 1% 1/8W	1	1061-0037
R017	RES MT FLM 1/8W 1% 750	1	1061-0037
R018	RES CAR COMP 1/4W 5% 3.3K	1	1065-0750
R019	RES CAR FILM 1/4W 5% 27K	1	1065-2702
R020	RES CAR FILM 1/4W 5% 27K	1	1065-2702
R021	RES CAR FILM 1/4W 5% 27K	1	1065-2702
R022	RES CAR COMP 1/4W 5% 100	1	1065-0100
R023	RES CAR COMP 1/4W 5% 100	1	1065-0100
R024	RES CAR FILM 1/4W 5% 27K	1	1065-2702
R025	RES CAR FILM 1/4W 5% 27K	1	1065-2702
R026	RES CAR COMP 1/4W 5% 100	1	1065-0100
R027	RES CAR COMP 1/4W 5% 100	1	1065-0100
R028	RES CAR FILM 1/4W 5% 56K	1	1065-0100
R029	RES VAR PC MT 20K 1T	1	1072-2001
R030	RES CAR FILM 1/4W 5% 39K	1	1065-3902
R031	RES CAR FILM 1/4W 5% 27K	1	1065-2702
R032	RES CAR COMP 1/4W 5% 100	1	1065-0100
R033	RES MT FLM 1/8W 1% 1K	1	1061-1001
R034	RES M.F. 2.43K 1% 1/8W	1	1061-2431

CKT REF	DESCRIPTION	QTY	TFT STOCK NO.
R036	RES CAR COMP 1/4W 5% 7.5K	1	1065-7501
R037	RES CAR COMP 1/4W 5% 75K	1	1065-7502
R038	RES CAR COMP 1/4W 5% 100	1	1065-0100
R039	RES CAR COMP 1/4W 5% 100	1	1065-0100
R040	RES MT FLM 1/8W 1% 1.5K	1	1061-1151
R041	RES MT FLM 1/8W 1% 1K	1	1061-1001
R042	RES VAR PC MT 10K 1T	1	1072-1001
R043	RES CAR COMP 1/4W 5% 7.5K	1	1065-7501
R044	RES CAR COMP 1/4W 5% 75K	1	1065-7502
R045	RES CAR FILM 1/4W 5% 1K	1	1065-1001
R046	RES CAR FILM 1/4W 5% 10K	1	1065-1002
R047	RES CAR COMP 1/4W 5% 3.3K	1	1065-3301
R048	RES CAR COMP 1/4W 5% 1.5K	1	1065-1501
R049	RES CAR FILM 1/4W 5% 390 OHM	1	1065-0390
R050	RES CAR FILM 1/4W 5% 2.2K	1	1065-2201
R051	RES CAR FILM 1/4W 5% 1K	1	1065-1001
R052	RES CAR FILM 1/4W 5% 10K	1	1065-1002
R053	RES CAR FILM 1/4W 5% 470 OHM	1	1065-0470
R054	RES CAR FILM 4.7K 1/4W 5%	1	1065-4701
R055	RES CAR COMP 1/4W 5% 5.6K	1	1065-5601
R056	RES CAR FILM 1/4W 5% 10K	1	1065-1002
R057	RES CAR COMP 1/4W 5% 5.6K	1	1065-5601
R058	RES CAR FILM 1/4W 5% 10K	1	1065-1002
R059	RES CAR COMP 1/4W 5% 5.6K	1	1065-5601
R060	RES CAR FILM 1/4W 5% 10K	1	1065-1002
R061	RES CAR COMP 1/4W 5% 100	1	1065-0100
R062	RES CAR COMP 1/4W 5% 100	1	1065-0100
R063	RES CAR FILM 1/4W 5% 10K	1	1065-1002
R064	RES MT FLM 1/8W 1% 7.5K	1	1061-7501
R065	RES MT FLM 1/8W 1% 7.5K	1	1061-7501
R066	RES CAR FILM 1/4W 5% 1K	1	1065-1001
R067	RES VAR PC MT 1K		

CKT REF	DESCRIPTION	QTY	TFT STOCK NO.
XU021	SOCKET, 1/C 8 PIN	1	2250-1008
XU022	SOCKET, 1/C 8 PIN	1	2250-1008
XU023	SOCKET, 1/C 8 PIN	1	2250-1008
XU024	SOCKET, 1/C 8 PIN	1	2250-1008
XU027	SOCKET, 1/C 8 PIN	1	2250-1008
XU028	SOCKET, 1/C 8 PIN	1	2250-1008
XU031	SOCKET, 1/C 8 PIN	1	2250-1008
Y001	XTAL 3.579 MHZ (850)	1	2400-2360

REV	DESCRIPTION	OR	DATE	APPD
1	PRODUCTION RELEASE		12-19-78	

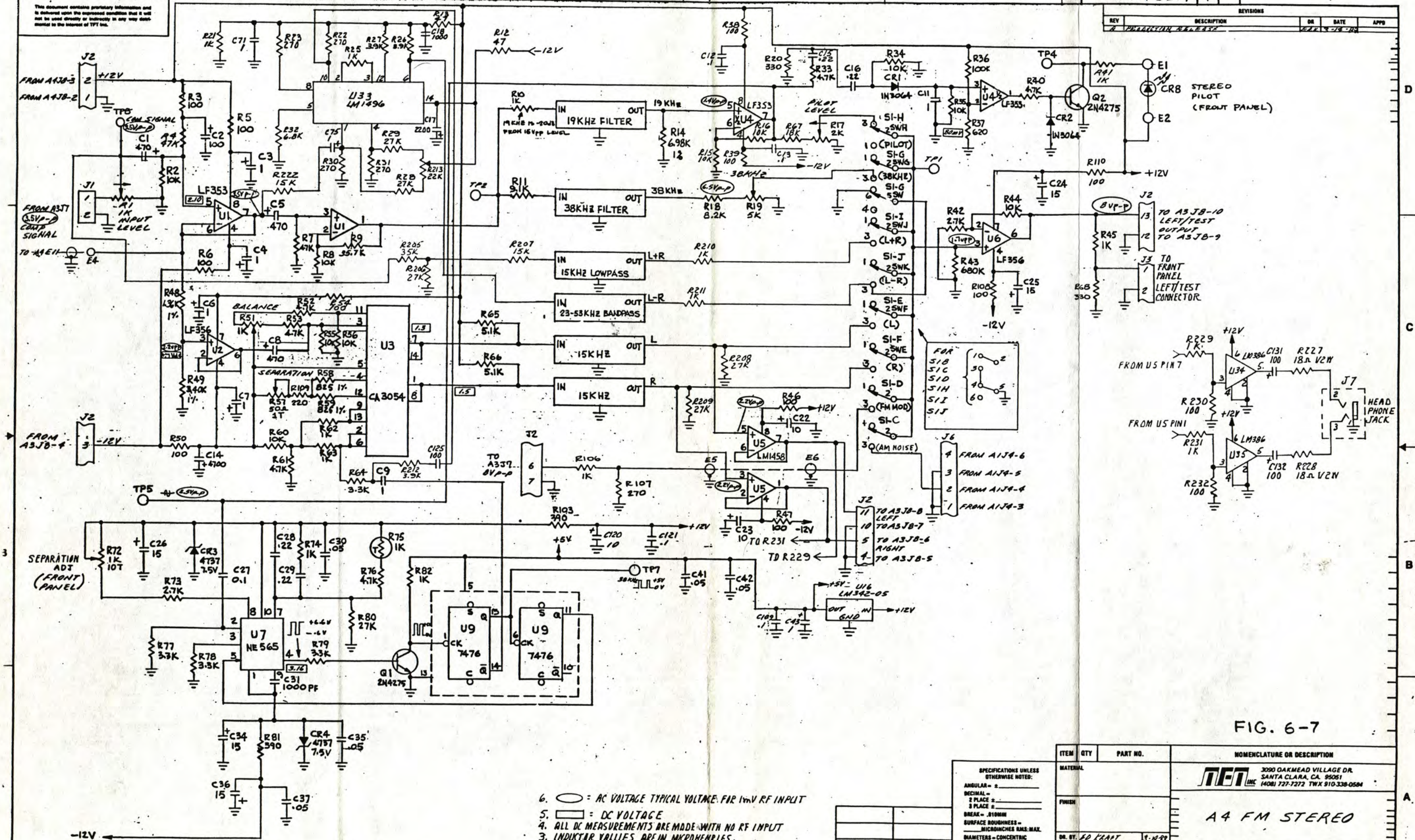

- 6. ○ = AC VOLTAGE TYPICAL VOLTAGE FOR 1mV RF INPUT
 - 5. □ = DC VOLTAGE
 - 4. ALL DC MEASUREMENTS ARE MADE WITH NO RF INPUT
 - 3. INDUCTOR VALUES ARE IN MICROHENRIES.
 - 2. CAPACITOR VALUES ARE IN MICROFARADS
 - 1. RESISTOR VALUES ARE IN OHMS, 1/4W, 5%
- NOTES: UNLESS OTHERWISE SPECIFIED.

FIG. 6-7

ITEM	QTY	PART NO.	NOMENCLATURE OR DESCRIPTION
MATERIAL			 3090 DAKMEAD VILLAGE DR. SANTA CLARA, CA 95051 (408) 727-7272 TWX 910-338-0504
FINISH			
DR. BY: <i>SD (PART)</i> 3-11-77 CK. BY: <i>K. Korman</i> 3-16-77 ENGR: <i>S. LAW</i> 2/18/78 S.A.			CODE IDENT NO. SIZE DRAWING NO. REV.
884 660B-3647 MODEL NEXT ASST APPLICATION			D 6601-3647 A SCALE NONE NO NOT SCALE PRINT SHEET 1 OF 1

This document contains proprietary information and is delivered upon the expressed condition that it will not be used directly or indirectly in any way detrimental to the interest of TFT Inc.

REVISIONS				
REV	DESCRIPTION	DR	DATE	APPD
A	RELEASED TO PRODUCTION	ERK	3-3-89	

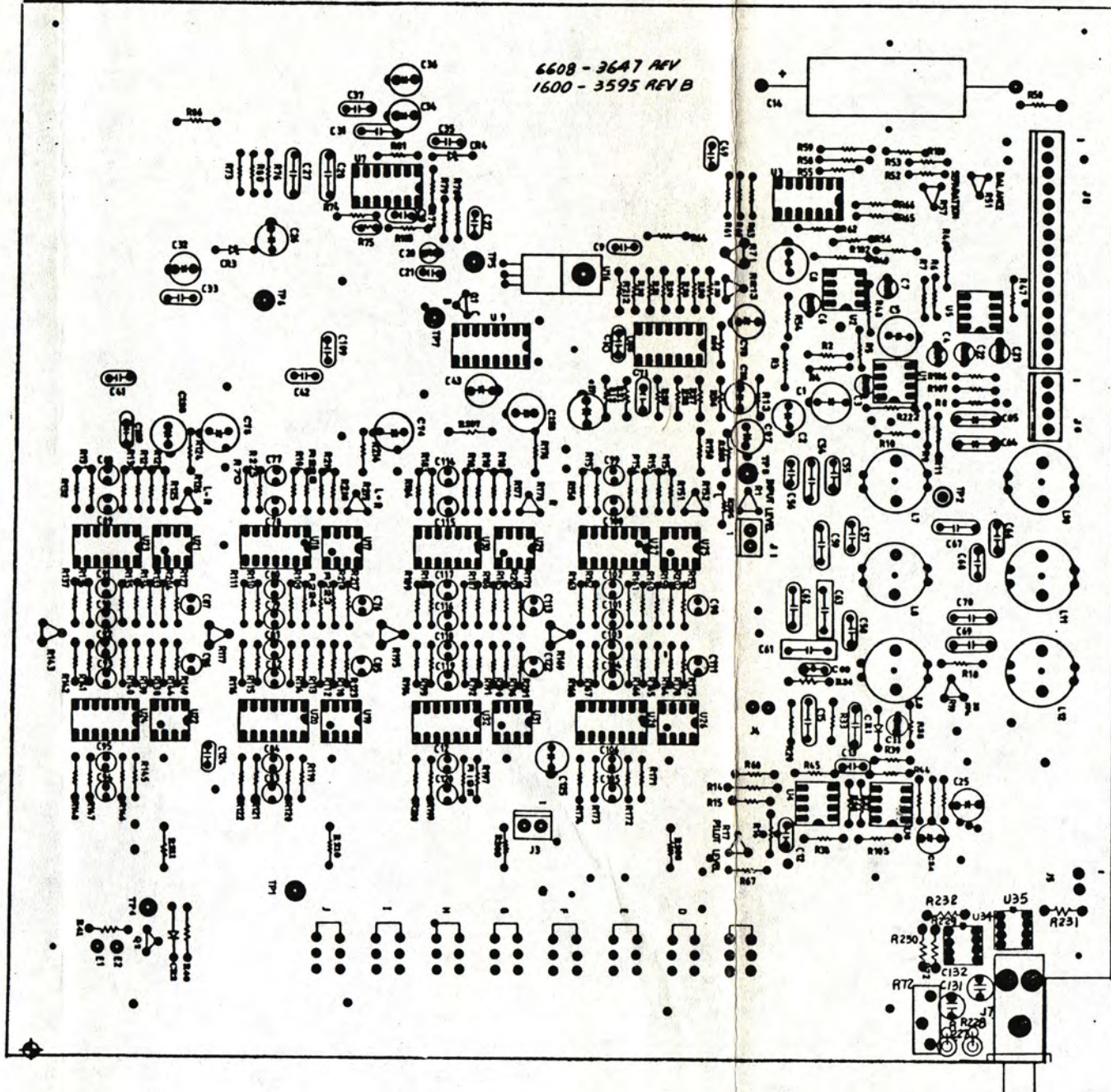

6608-3647 REV
1600-3595 REV B

FIG. 6-8

SCHEMATIC 6601-3647
PC BD. 1600-3595 REV B.
NOTES:

STEAM POWERED RADIO.COM

884	5102-3548
MODEL	NEXT ASSY
APPLICATION	

SPECIFICATIONS UNLESS OTHERWISE NOTED:
 ANGULAR - ± _____
 DECIMAL - _____
 2 PLACE ± _____
 3 PLACE ± _____
 BREAK - .010MIN
 SURFACE ROUGHNESS - _____ MICROINCHES RMS: MAX.
 DIAMETERS - CONCENTRIC WITHIN .005 TIR.
 FILLET RADIUS - _____ MAX
 THREADS - CLASS 2 MARK IN ACCORDANCE WITH TFT SPEC 5300-1058

ITEM	QTY	PART NO.	NOMENCLATURE OR DESCRIPTION			
MATERIAL			 3090 OAKMEAD VILLAGE DR. SANTA CLARA, CA. 95051 (408) 727-7272 TWX 910-338-0584 PCB ASSEMBLY A4 FM STEREO			
FINISH						
DR. BY. ED KRAFT		2-3-88	CODE IDENT NO.	SIZE	DRAWING NO.	REV.
CK. BY. C. S. HO		3-6-88	—	C	6608-3647	A
ENGR. Y. S. LAW		3/18/88				
MFB.						
Q.A.						
			SCALE 1:1	DO NOT SCALE PRINT		SHEET 1 OF 1

CKT REF	DESCRIPTION	QTY	TFT STOCK NO.
C001	CAP ELEC 470MF 25V VERT HNT	1	1010-0045
C002	CAP ELECT VT MT 100UF (NO SUB.)	1	1010-0110
C003	CAP ELECT 1.0MFD 50V RADIAL	1	1010-0009
C004	CAP ELECT 1.0MFD 50V RADIAL	1	1010-0009
C005	CAP ELEC 470MF 25V VERT HNT	1	1010-0045
C006	CAP ELECT 1.0MFD 50V RADIAL	1	1010-0009
C007	CAP ELECT 1.0MFD 50V RADIAL	1	1010-0009
C008	CAP ELEC 470MF 25V VERT HNT	1	1010-0045
C009	CAP CER DISC 1MFD	1	1005-0001
C011	CAP ELECT 1.0MFD 50V RADIAL	1	1010-0009
C012	CAP CER 0.1MF CK05BK K	1	1015-0001
C013	CAP CER 0.1MF CK05BK K	1	1015-0001
C014	CAP ELECT 4700MFD 35V	1	1010-0472
C015	CAP CER DISC 22 MFD 50V	1	1005-2030
C016	CAP POLY .22MFD 100V	1	1002-0220
C017	CAP ELECT 2200UF 16V VERT MT	1	1010-0223
C018	CAP ELECT 1000MFD 25V VERT MT	1	1010-1000
C022	CAP ELECT 10 MFD 25V VERT MT	1	1010-0099
C023	CAP ELECT 10 MFD 25V VERT MT	1	1010-0099
C024	CAP ELECT 15UF 25V VERT HT	1	1010-0151
C025	CAP ELECT 15UF 25V VERT HT	1	1010-0151
C026	CAP ELECT 15UF 25V VERT HT	1	1010-0151
C027	CAP CER 0.1MF CK05BK K	1	1015-0001
C028	CAP POLY .22MFD 100V	1	1002-0220
C029	CAP POLY .22MFD 100V	1	1002-0220
C030	CAP CER DISC .05MFD/25V	1	1005-5039
C031	CAP MICA 1000PF 500V	1	1001-0102
C034	CAP ELECT 15UF 25V VERT HT	1	1010-0151
C035	CAP CER DISC .05MFD/25V	1	1005-5039
C036	CAP ELECT 15UF 25V VERT HT	1	1010-0151
C037	CAP CER DISC .05MFD/25V	1	1005-5039
C041	CAP CER DISC .05MFD/25V	1	1005-5039
C042	CAP CER DISC .05MFD/25V	1	1005-5039
C043	CAP ELECT 1.0MFD 50V RADIAL	1	1010-0009
C071	CAP CER DISC 1MFD	1	1005-0001
C075	CAP CER DISC 1MFD	1	1005-0001
C109	CAP CER 0.1MF CK05BK K	1	1015-0001
C120	CAP ELECT 10 MFD 25V VERT HT	1	1010-0099
C121	CAP CER 0.1MF CK05BK K	1	1015-0001
C125	CAP ELECT VT MT 100UF (NO SUB.)	1	1010-0110
C131	CAP ELECT VT MT 100UF (NO SUB.)	1	1010-0110
C132	CAP ELECT VT MT 100UF (NO SUB.)	1	1010-0110
CR01	DIO 1N3064	1	1281-3064
CR02	DIO 1N3064	1	1281-3064
CR03	DIO 1N4737 ZENER	1	1283-4737
CR04	DIO 1N4737 ZENER	1	1283-4737

CKT REF	DESCRIPTION	QTY	TFT STOCK NO.
J001	PLUG, LOCKING 2 PIN	1	2250-6002
J002	PLUG 7 PIN MOLEX	1	2250-6007
J003	PLUG, LOCKING 2 PIN	1	2250-6002
J006	PLUG, 4 PIN	1	2250-6004
J007	STEREO PHONE JACK PC HNT 1/4	1	2250-3508
J02A	CONN 8 PIN MOLEX	1	2250-6008
PCB1	PCB A4 FM STEREO/ACTIVE FIL844	1	1600-3595
Q001	TRANS 2N4275	1	1271-4275
Q002	TRANS 2N4275	1	1271-4275
R001	CERMET POT TRIM 1K TOP/BOT ADJ	1	1072-1005
R002	RES CAR FILM 1/4W 5% 10K	1	1065-1002
R003	RES CAR COMP 1/4W 5% 10K	1	1065-0100
R004	RES CAR FILM 1/4W 5% 47K	1	1065-4702
R005	RES CAR COMP 1/4W 5% 100	1	1065-0100
R006	RES CAR COMP 1/4W 5% 100	1	1065-0100
R007	RES CAR FILM 1/4W 5% 47K	1	1065-4702
R008	RES CAR FILM 1/4W 5% 10K	1	1065-1002
R009	RES MT FLM 35.7K 1/8W 1%	1	1061-3572
R010	RES CAR FILM 1/4W 5% 1K	1	1065-1001
R011	RES CAR COMP 1/4W 5% 9.1K	1	1065-9101
R012	RES CAR FILM 1/4W 5% 47 OHM	1	1065-0047
R013	RES CAR FILM 1/4W 5% 47 OHM	1	1065-0047
R014	RES N.F. 6.98K 1% 1/8W	1	1061-0081
R015	RES CAR FILM 1/4W 5% 10K	1	1065-1002
R016	RES CAR FILM 1/4W 5% 10K	1	1065-1002
R017	CERMET POT TRIM 2K TOP/BOT ADJ	1	1072-2011
R018	RES CAR FILM 1/4W 5% 56K	1	1065-5602
R019	CERMET POT TRIM 5K TOP/BOT ADJ	1	1072-5011
R020	RES CAR COMP 1/4W 5% 330	1	1065-0330
R021	RES CAR FILM 1/4W 5% 1K	1	1065-1001
R022	RES CAR COMP 1/4W 5% 270	1	1065-0270
R023	RES CAR COMP 1/4W 5% 270	1	1065-0270
R025	RES CAR FILM 1/4W 5% 1K	1	1065-1001
R026	RES CAR FILM 1/4W 5% 33K	1	1065-3302
R027	RES CAR FILM 1/4W 5% 33K	1	1065-3302
R028	RES CAR FILM 1/4W 5% 27K	1	1065-2702
R029	RES CAR FILM 1/4W 5% 27K	1	1065-2702
R030	RES CAR COMP 1/4W 5% 270	1	1065-0270
R031	RES CAR COMP 1/4W 5% 270	1	1065-0270
R032	RES CAR COMP 1/4W 5% 6.8K	1	1065-6801
R033	RES CAR FILM 4.7K 1/4W 5%	1	1065-4701
R034	RES CAR FILM 1/4W 5% 10K	1	1065-1002
R035	RES CAR FILM 1/4W 5% 10K	1	1065-1002
R036	RES CAR COMP 1/4W 5% 100K	1	1065-1003
R037	RES CAR FILM 1/4W 5% 620 OHM	1	1065-0620
R038	RES CAR COMP 1/4W 5% 100	1	1065-0100

CKT REF	DESCRIPTION	QTY	TFT STOCK NO.
R039	RES CAR COMP 1/4W 5% 100	1	1065-0100
R040	RES CAR FILM 4.7K 1/4W 5%	1	1065-4701
R041	RES CAR FILM 1/4W 5% 1K	1	1065-1001
R042	RES CAR FILM 1/4W 5% 2.7K	1	1065-2701
R043	RES CAR COMP 1/4W 5% 680K	1	1065-6803
R044	RES CAR FILM 1/4W 5% 10K	1	1065-1002
R045	RES CAR FILM 1/4W 5% 1K	1	1065-1001
R046	RES CAR COMP 1/4W 5% 100	1	1065-0100
R047	RES CAR COMP 1/4W 5% 100	1	1065-0100
R048	RES MT FLM 1/8W 1% 1.37K	1	1061-1370
R049	RES CAR COMP 1/4W 5% 1.5K	1	1065-1501
R050	RES CAR COMP 1/4W 5% 100	1	1065-0100
R051	CERMET POT TRIM 1K TOP/BOT ADJ	1	1072-1005
R052	RES CAR FILM 4.7K 1/4W 5%	1	1065-4701
R053	RES CAR FILM 4.7K 1/4W 5%	1	1065-4701
R054	RES CAR COMP 1/4W 5% 100	1	1065-0100
R055	RES CAR FILM 1/4W 5% 10K	1	1065-1002
R056	RES CAR FILM 1/4W 5% 10K	1	1065-1002
R057	CERMET POT TRIM 100 TOP/BOT ADJ	1	1072-0101
R058	RES MT FLM 1/8W 1% 825	1	1061-0825
R059	RES MT FLM 1/8W 1% 825	1	1061-0825
R060	RES CAR FILM 1/4W 5% 10K	1	1065-1002
R061	RES CAR FILM 4.7K 1/4W 5%	1	1065-4701
R062	RES CAR FILM 1/4W 5% 1K	1	1065-1001
R063	RES CAR FILM 1/4W 5% 1K	1	1065-1001
R064	RES CAR COMP 1/4W 5% 3.3K	1	1065-3301
R065	RES CAR COMP 1/4W 5% 5.1K	1	1065-5101
R066	RES CAR COMP 1/4W 5% 5.1K	1	1065-5101
R067	RES CAR COMP 1/4W 5% 18K	1	1065-1802
R068	RES CAR COMP 1/4W 5% 330	1	1065-0330
R072	RES VAR PC MT 1K 10T	1	1069-1001
R073	RES CAR FILM 1/4W 5% 2.7K	1	1065-2701
R074	RES CAR FILM 1/4W 5% 1K	1	1065-1001
R075	THERISTOR 1K	1	1080-0013
R076	RES CAR FILM 4.7K 1/4W 5%	1	1065-4701
R077	RES CAR COMP 1/4W 5% 3.3K	1	1065-3301
R078	RES CAR COMP 1/4W 5% 3.3K	1	1065-3301
R079	RES CAR COMP 1/4W 5% 3.3K	1	1065-3301
R080	RES CAR FILM 1/4W 5% 27K	1	1065-2702
R081	RES CAR FILM 1/4W 5% 390 OHM	1	1065-0390
R082	RES CAR FILM 1/4W 5% 1K	1	1065-1001
R103	RES CAR FILM 1/4W 5% 390 OHM	1	1065-0390
R106	RES CAR FILM 1/4W 5% 1K	1	1065-1001
R107	RES CAR COMP 1/4W 5% 270	1	1065-0270
R109	RES CAR COMP 1/4W 5% 100	1	1065-0100
R109	RES CAR FILM 1/4W 5% 220	1	1065-0220

CKT REF	DESCRIPTION	QTY	TFT STOCK NO.
R110	RES CAR COMP 1/4W 5% 100	1	1065-0100
R205	RES CAR COMP 1/4W 5% 22K	1	1065-2202
R206	RES CAR FILM 1/4W 5% 27K	1	1065-2702
R207	RES CAR FILM 1/4W 5% 15K	1	1065-1502
R208	RES CAR FILM 1/4W 5% 27K	1	1065-2702
R209	RES CAR FILM 1/4W 5% 27K	1	1065-2702
R210	RES CAR FILM 1/4W 5% 1K	1	1065-1001
R211	RES CAR FILM 1/4W 5% 1K	1	1065-1001
R212	RES CAR COMP 1/4W 5% 3.9K	1	1065-3901
R213	CERMET POT TRIM 5K TOP/BOT ADJ	1	1072-5011
R222	RES CAR FILM 1/4W 5% 15K	1	1065-1502
R223	RES MT FLM 14.3K 1/8W 1%	1	1061-1432
R227	RES CC 18 5% 1/2W HI REL	1	1067-0017
R228	RES CC 18 5% 1/2W HI REL	1	1067-0017
R229	RES CAR FILM 1/4W 5% 1K	1	1065-1001
R230	RES CAR COMP 1/4W 5% 100	1	1065-0100
R231	RES CAR FILM 1/4W 5% 1K	1	1065-1001
R232	RES CAR COMP 1/4W 5% 100	1	1065-0100
S001	SW PB 8P "F" SER BLK/BLU 884	1	1850-0107
U001	I/C LF353N DUAL J FET OP. AMP	1	1100-0353
U002	I/C LF356N	1	1100-0356
U003	I/C CA3054	1	1100-3054
U004	I/C LF353N DUAL J FET OP. AMP	1	1100-0353
U005	I/C LM1458N	1	1101-1458
U006	I/C LF356N	1	1100-0356
U007	I/C NE565A	1	1100-0565
U009	I/C SN7476N	1	1100-7476
U016	I/C LM342P	1	1100-7817
U033	I/C LM1496N BALANCED MOD/DEMON	1	1100-1496
XU01	SOCKET, I/C 8 PIN	1	2250-1008
XU02	SOCKET, I/C 8 PIN	1	2250-1008
XU033	SOCKET, I/C 14PIN	1	2250-1014
XU034	SOCKET, I/C 8 PIN	1	2250-1008
XU035	SOCKET, I/C 8 PIN	1	2250-1008
XU04	SOCKET, I/C 8 PIN	1	2250-1008
XU05	SOCKET, I/C 8 PIN	1	2250-1008
XU06	SOCKET, I/C 8 PIN	1	2250-1008
XU07	SOCKET I/C 14PIN	1	2250-1014
XU09	SOCKET, I/C 16 PIN	1	2250-1016

This document contains proprietary information and is delivered upon the expressed condition that it will not be used directly or indirectly in any way detrimental to the interest of TPT Inc.

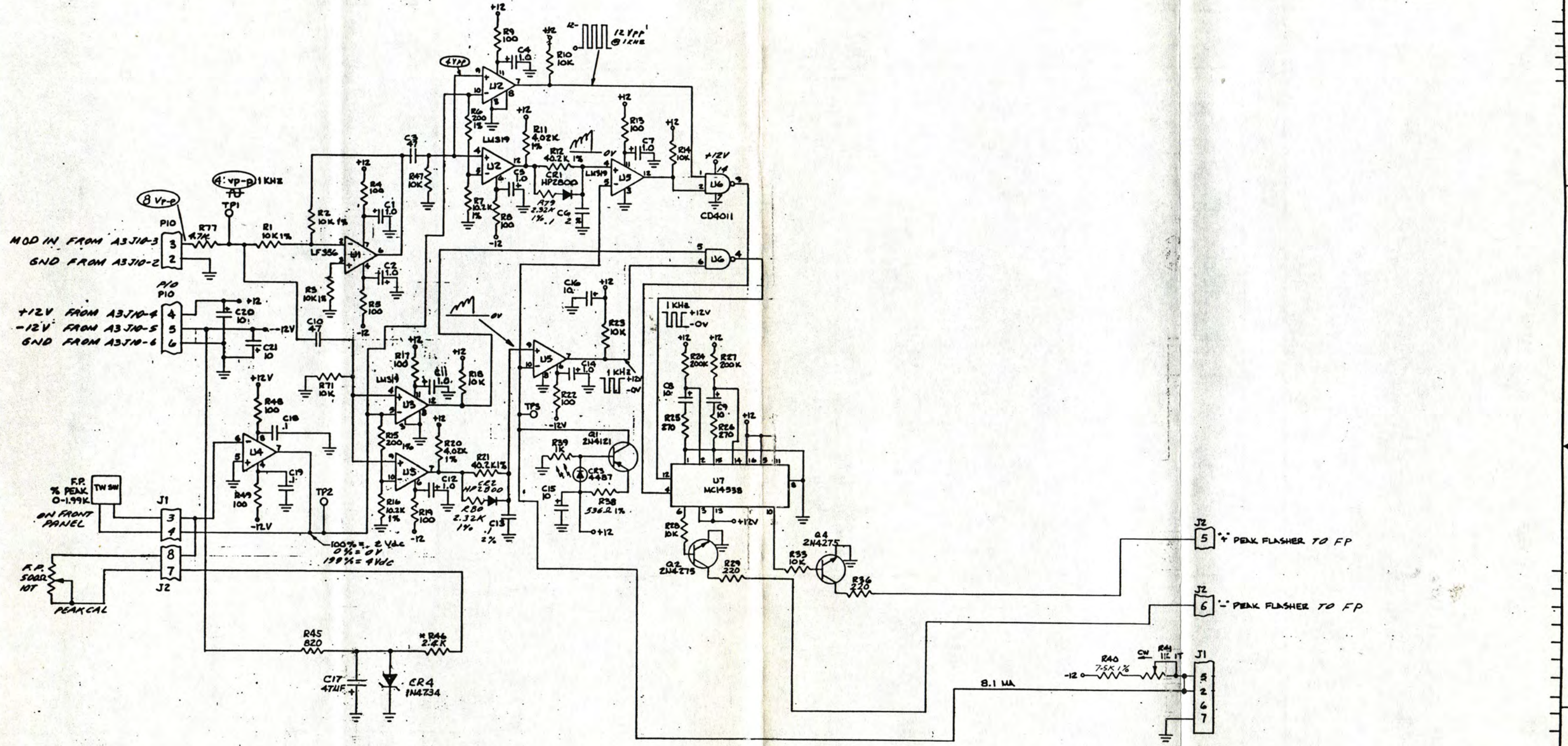

- 8. = DC VOLTAGE
- 7. = AC VOLTAGE
- 6. ALL AC LEVELS MEASURED WITH 100% MODULATION (INPUT EQUAL TO 8Vp-p)
- 5. *FACTORY SELECTED VALUE. TYPICAL VALUE SHOWN
- 4. PCB 1600-3410, MAT'L LIST #A661 6608-3644
- 3. INDUCTOR VALUES ARE IN MICROHENRIES.
- 2. CAPACITOR VALUES ARE IN MICROFARADS.
- 1. RESISTOR VALUES ARE IN OHMS, 1/4W 5%.

NOTES, UNLESS OTHERWISE SPECIFIED;

FIG. 6-9

884	6608-3644
MODEL	NEXT ASST
APPLICATION	

SPECIFICATIONS UNLESS OTHERWISE NOTED:
 ANGULAR - ±
 DECIMAL -
 2 PLACE ±
 3 PLACE ±
 BREAK - .010MIN
 SURFACE ROUGHNESS - MICROINCHES RMS MAX.
 DIAMETERS - CONCENTRIC WITHIN .005 TOL.
 FILLET RADIUS - MAX
 THREADS - CLASS 2 MARK IN ACCORDANCE WITH TPT SPEC 5308-1058

ITEM	QTY	PART NO.	NOMENCLATURE OR DESCRIPTION			
MATERIAL			3090 OAKMEAD VILLAGE DR. SANTA CLARA, CA. 95051 (408) 727-7272 TWX 910-338-0584 AG DISPLAY DRIVER			
FINISH						
DR. BY	ED KRAY	P-2-88	CODE IDENT NO.	SIZE	DRAWING NO.	REV.
CHK. BY	102	3-14-88	D	6601-3644	A	
ENGR.	V. S. LAW	1A-1-88	SCALE	NO. OF SHEETS	DO NOT SCALE PRINT	SHEET 1 of 1

This document contains proprietary information and is delivered upon the expressed condition that it will not be used directly or indirectly in any way detrimental to the interest of TFT Inc.

REVISIONS				
REV	DESCRIPTION	DR	DATE	APPD
A	RELEASE OF PRODUCTION	FEL	2-2-80	

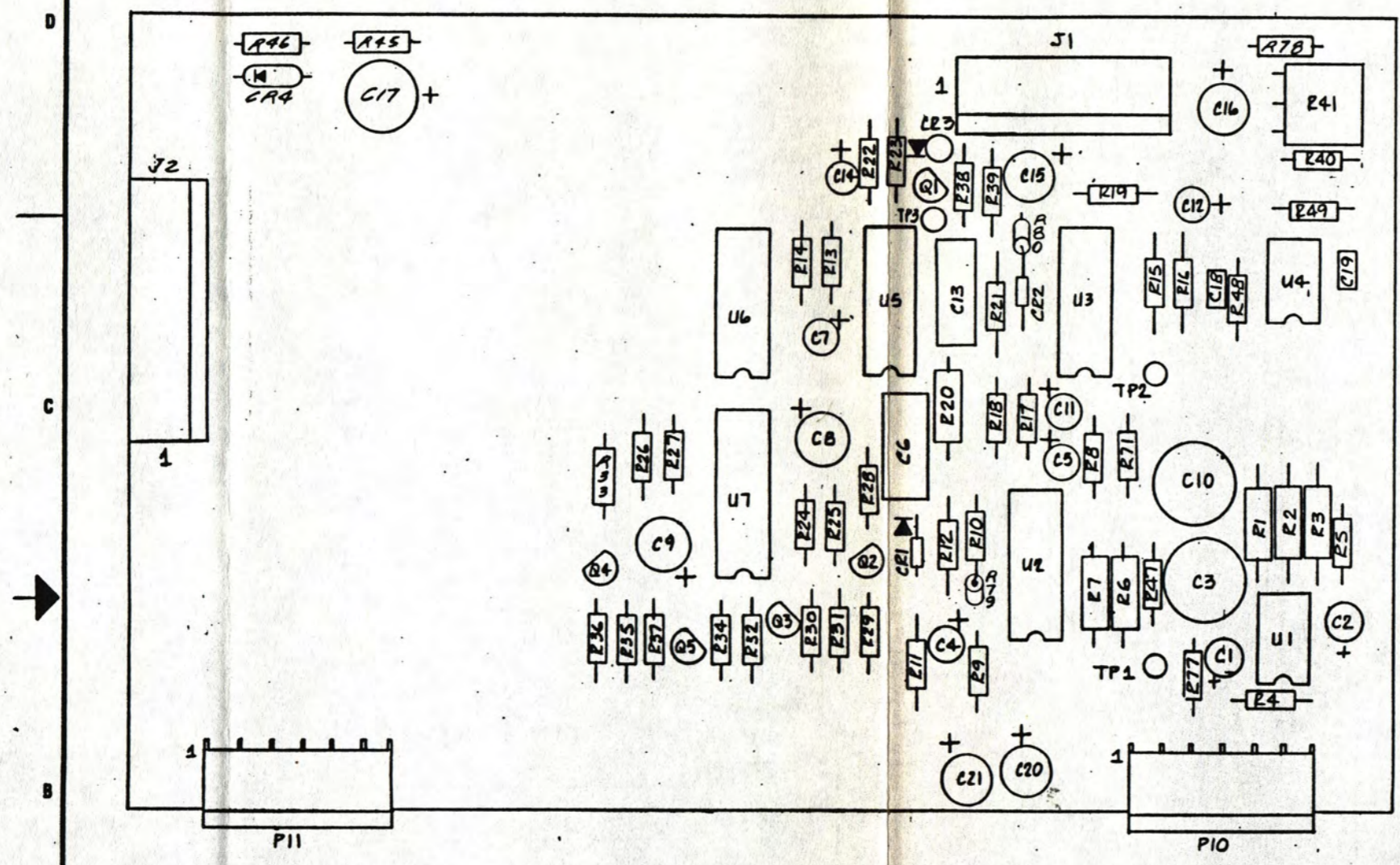

FIG. 6-10

- 3. FOR PCB SEE 1600-3410 (LATEST REV.)
 - 2. FOR SCHEMATIC SEE 6601-3644 (LATEST REV.)
 - 1. FOR MATL LIST SEE 660B-3644 (LATEST REV.)
- NOTES: UNLESS OTHERWISE SPECIFIED

SPECIFICATIONS UNLESS OTHERWISE NOTED:
 ANGULAR = ± —
 DECIMAL = 2 PLACE ± —
 3 PLACE ± —
 BREAK = .010MIN
 SURFACE ROUGHNESS = — MICROINCHES RMS: MAX.
 DIAMETERS = CONCENTRIC WITHIN .005 TIR.
 FILLET RADIUS = — MAX
 THREADS = CLASS 2 MARK IN ACCORDANCE WITH TFT SPEC 8300-1088

584	5102-3548
MODEL	NEXT ASSY
APPLICATION	

ITEM	QTY	PART NO.	NOMENCLATURE OR DESCRIPTION			
MATERIAL			3090 OAKMEAD VILLAGE DR. SANTA CLARA, CA. 95051 (408) 727-7272 TWX 910-338-0584			
FINISH						
DR. BY: <i>LD KEARF</i> 2-3-80			CODE IDENT NO.	SIZE	DRAWING NO.	REV.
CK. BY: <i>KL</i> 2-5-80			C		660B-3644	A
ENGR. <i>Y.S. LAW</i> 3/8/80			SCALE 2/1 DO NOT SCALE PRINT SHEET 1 OF 1			
MFG.						
G.A.						

CKT REF	DESCRIPTION	QTY	TFT STOCK NO.
C001	CAP ELECT 1.0MFD 50V RADIAL	1	1010-0009
C002	CAP ELECT 1.0MFD 50V RADIAL	1	1010-0009
C003	CAP ELECT NON POLAR 47MFD 25V	1	1010-0048
C004	CAP ELECT 1.0MFD 50V RADIAL	1	1010-0009
C005	CAP ELECT 1.0MFD 50V RADIAL	1	1010-0009
C006	CAP MET POLY .01UF +21/2	1	1006-0002
C007	CAP ELECT 1.0MFD 50V RADIAL	1	1010-0009
C008	CAP ELECT 10 MFD 25V VERT HT	1	1010-0099
C009	CAP ELECT 10 MFD 25V VERT HT	1	1010-0099
C010	CAP ELECT NON POLAR 47MFD 25V	1	1010-0048
C011	CAP ELECT 1.0MFD 50V RADIAL	1	1010-0009
C012	CAP ELECT 1.0MFD 50V RADIAL	1	1010-0009
C013	CAP MET POLY .01UF +21/2	1	1006-0002
C014	CAP ELECT 1.0MFD 50V RADIAL	1	1010-0009
C015	CAP ELECT 10 MFD 25V VERT HT	1	1010-0099
C016	CAP ELECT 10 MFD 25V VERT HT	1	1010-0099
C017	CAP ELECT 47MFD 35V VERT HT	1	1010-0470
C018	CAP CER 0.1MF CK05BK K	1	1015-0001
C019	CAP CER 0.1MF CK05BK K	1	1015-0001
C020	CAP ELECT 10 MFD 25V VERT HT	1	1010-0099
C021	CAP ELECT 10 MFD 25V VERT HT	1	1010-0099
CR01	DIO HP5082 HOT CARRIER	1	1282-2800
CR02	DIO HP5082 HOT CARRIER	1	1282-2800
CR03	LED HP 5082-4487 CLEAR	1	1285-4487
CR04	DIO 1N4734A ZENER	1	1283-4734
J001	PLUG LOCK MOLEX 7 PIN	1	2250-6507
J002	CONN 8 PIN MOLEX	1	2250-6008
P010	SOCKET LOCK 6 PIN MOLEX	1	2250-5206
PCB1	PCB A6 DISPLAY DRIVER	1	1600-3410
Q001	TRANS 2N4121	1	1271-4121
Q002	TRANS 2N4275	1	1271-4275
Q003	TRANS 2N4121	1	1271-4121
Q004	TRANS 2N4275	1	1271-4275
Q005	TRANS 2N4121	1	1271-4121
R001	RES MT FLM 1/8W .1% 10K	1	1058-1002
R002	RES MT FLM 1/8W .1% 10K	1	1058-1002
R003	RES MT FLM 1/8W .1% 10K	1	1058-1002
R004	RES CAR COMP 1/4W 5% 100	1	1065-0100
R005	RES CAR COMP 1/4W 5% 100	1	1065-0100
R006	RES MT FLM 1/8W 1% 200	1	1061-1022
R007	RES MT FLM 1/8W 1% 200	1	1061-1022
R008	RES CAR COMP 1/4W 5% 100	1	1065-0100
R009	RES CAR COMP 1/4W 5% 100	1	1065-0100
R010	RES CAR FILM 1/4W 5% 10K	1	1065-1002
R011	RES MT FLM 1/8W 1% 4.02K	1	1061-4021
R012	RES MT FLM 1/8W 1% 40.2K	1	1061-4022

CKT REF	DESCRIPTION	QTY	TFT STOCK NO.
R013	RES CAR COMP 1/4W 5% 100	1	1065-0100
R014	RES CAR FILM 1/4W 5% 10K	1	1065-1002
R015	RES MT FLM 1/8W 1% 200	1	1061-1022
R016	RES MT FLM 1/8W 1% 200	1	1061-1022
R017	RES CAR COMP 1/4W 5% 100	1	1065-0100
R018	RES CAR FILM 1/4W 5% 10K	1	1065-1002
R019	RES CAR COMP 1/4W 5% 100	1	1065-0100
R020	RES MT FLM 1/8W 1% 4.02K	1	1061-4021
R021	RES MT FLM 1/8W 1% 40.2K	1	1061-4022
R022	RES CAR COMP 1/4W 5% 100	1	1065-0100
R023	RES CAR FILM 1/4W 5% 10K	1	1065-1002
R024	RES CAR 1/4W 5% 200K	1	1065-2003
R025	RES CAR COMP 1/4W 5% 270	1	1065-0270
R026	RES CAR COMP 1/4W 5% 270	1	1065-0270
R027	RES CAR 1/4W 5% 200K	1	1065-2003
R028	RES CAR FILM 1/4W 5% 10K	1	1065-1002
R029	RES CAR FILM 1/4W 5% 220	1	1065-0220
R030	RES CAR FILM 1/4W 5% 10K	1	1065-1002
R031	RES CAR FILM 1/4W 5% 10K	1	1065-1002
R032	RES CAR FILM 1/4W 5% 1K	1	1065-1001
R033	RES CAR FILM 1/4W 5% 10K	1	1065-1002
R036	RES CAR FILM 1/4W 5% 220	1	1065-0220
R037	RES CAR FILM 1/4W 5% 1K	1	1065-1001
R038	RES M.F. 110 1% 1/8W	1	1061-0110
R039	RES CAR FILM 1/4W 5% 1K	1	1065-1001
R040	RES CAR FILM 1/4W 5% 1K	1	1065-1001
R041	RES VAR FC HT 1K 1T	1	1072-1001
R045	RES CAR FILM 1/4W 5% 820 OHM	1	1065-0820
R046	RES CAR FILM 1/4W 5% 2.4K	1	1065-2401
R047	RES CAR FILM 1/4W 5% 10K	1	1065-1002
R048	RES CAR COMP 1/4W 5% 100	1	1065-0100
R049	RES CAR COMP 1/4W 5% 100	1	1065-0100
R071	RES CAR FILM 1/4W 5% 10K	1	1065-1002
R077	RES CAR FILM 4.7K 1/4W 5%	1	1065-4701
R106	RES CAR COMP 1/4W 5% 56	1	1065-0356
TP01	SOLID PIN PLUG	1	2140-0071
TP02	SOLID PIN PLUG	1	2140-0071
TP03	SOLID PIN PLUG	1	2140-0071
U001	I/C LF356N	1	1100-0356
U002	LM319 HI-SPEED DUAL COMPTR	1	1100-0319
U003	LM319 HI-SPEED DUAL COMPTR	1	1100-0319
U004	I/C LM1458N	1	1101-1458
U005	LM319 HI-SPEED DUAL COMPTR	1	1100-0319
U006	I/C RCA CD4011 QD 2-NAND	1	1102-4011
U007	IC MC14538B CMOS MSI	1	1102-4538
XU01	SOCKET, I/C 8 PIN	1	2250-1008

CKT REF	DESCRIPTION	QTY	TFT STOCK NO.
XU02	SOCKET I/C 14PIN	1	2250-1014
XU03	SOCKET, I/C 16 PIN	1	2250-1016
XU04	SOCKET, I/C 8 PIN	1	2250-1008
XU12	SOCKET, I/C 8 PIN	1	2250-1008

TFT Inc.

P.O. BOX 58088
 3090 OAKMEAD VILLAGE DRIVE
 SANTA CLARA, CA. 95052-8088
 (408) 727-7272

DATE IS 19 Sep 1989

TIME IS 09:38:55

MODEL NUMBER IS 884

SYSTEM TEST DATA CUSTOMER FAMILY STATION INC.

S.O.# 24716 TESTED BY Jeff Anderson

S/N#(884) 1070463 S/N#() 10

S/N#() _____

REMARKS _____

=====

TEST CONDITIONS	MEASURED VALUE	LOWER LIMIT	UPPER LIMIT
-----------------	----------------	-------------	-------------

=====

MONITOR FREQUENCY=88.1 MHz

844/884 FM MONITOR TESTS

AUDIO DISTORTION @.4kHz	.07 %	0.00	.10
AUDIO RESP @.4kHz	-.02 dB rel.4kHz	-.20	.20
AUDIO RESP @1kHz	-.05 dB rel.4kHz	-.20	.20
AUDIO RESP @3kHz	-.07 dB rel.4kHz	-.20	.20
AUDIO RESP @5kHz	-.07 dB rel.4kHz	-.20	.20
AUDIO RESP @7.5kHz	-.07 dB rel.4kHz	-.20	.20
AUDIO RESP @10kHz	-.07 dB rel.4kHz	-.20	.20
AUDIO RESP @15kHz	-.07 dB rel.4kHz	-.20	.20
SIGNAL TO NOISE RATIO	-77.80 dB	-90.00	-70.00

MONITOR FREQUENCY=107.9 MHz

844/884 FM MONITOR TESTS

AUDIO DISTORTION @.4kHz	.05 %	0.00	.10
AUDIO RESP @.4kHz	-.02 dB rel.4kHz	-.20	.20
AUDIO RESP @1kHz	-.05 dB rel.4kHz	-.20	.20
AUDIO RESP @3kHz	-.07 dB rel.4kHz	-.20	.20
AUDIO RESP @5kHz	-.07 dB rel.4kHz	-.20	.20
AUDIO RESP @7.5kHz	-.07 dB rel.4kHz	-.20	.20
AUDIO RESP @10kHz	-.10 dB rel.4kHz	-.20	.20
AUDIO RESP @15kHz	-.10 dB rel.4kHz	-.20	.20
SIGNAL TO NOISE RATIO	-84.18 dB	-90.00	-70.00

ABOVE TESTS PROVIDED BY A H.P. 8954-S AUTOMATED RF TEST SYSTEM

IMPORTANT NOTICE

CLAIM FOR DAMAGE IN SHIPMENT

This instrument was thoroughly tested and carefully packed in our factory. It was shipped FOB Santa Clara and when the carrier accepted it, title and insurance liability passed to you. Should you receive this instrument in damaged condition, apparent or concealed, claim for damage must be made immediately upon the carrier *and* your insurance company. Either may refuse to honor the claim if you do not act promptly. This equipment must not be returned to the factory without our prior approval.

DEFECTIVE EQUIPMENT

Should this equipment appear to be defective, call or write the Customer Service Department, TFT, Inc., 3090 Oakmead Village Drive, Santa Clara, CA. 95051, Telephone number: (408)727-7272. If it is determined that the unit is to be returned to TFT, you will be provided a Return Authorization number. Merchandise will not be accepted without the Return number. Please ship unit prepaid and unit will be returned prepaid on completion of repairs.

SHORTAGE CLAIMS

Shortage claims will not be honored after 10 days of receipt of shipment.



TIME AND FREQUENCY TECHNOLOGY, INC.

3090 OAKMEAD VILLAGE DR., SANTA CLARA, CA. 95051 (408)727-7272 TWX 910-338-0584