



Technical Support

TECHNICAL NOTE

Technical Note TN-873 TM8100 Control Head Attach and Detach Procedure

10 June 2004

Applicability

This Technical Note applies to the TM8100 family of mobile radios, including the TM8105, TM8110 and TM8115.

1. Control Head Removal

1. Disconnect the transceiver from any test equipment or power supply.
2. Note the two points where the control head should be levered off the radio body. As shown in Figure 3.1 below, these points are indicated by a dot-dash-dot marks on the underside of the radio body. The lever point is between the rubber seal and the front panel of the control head.
3. Using each of the lever points, insert the blade of a medium-sized (about 5mm) flat-bladed screwdriver and lever off the control head with an up-and-forward motion.
4. After detaching the control head, disconnect the control-head loom at the connector on the radio body. Refer to Figure 3.2 next page.

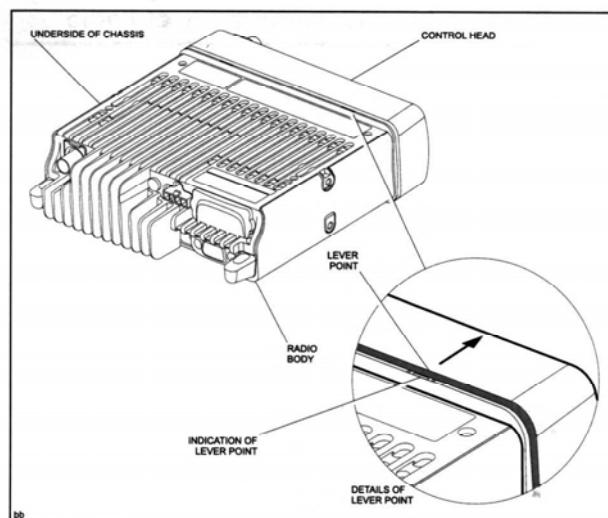

Figure 3.1 Lever points for detaching the control head from the radio body

2. Control Head Attachment

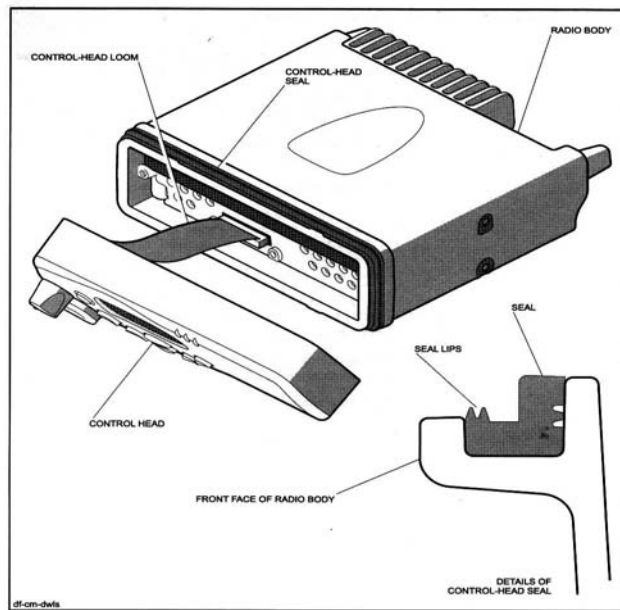

Figure 3.2 Details of the seal between the radio body and control head

It is highly recommended the body seal be replaced when replacing the control head to preserve the integrity of the radio's IP54 rating. There is a kit of 10x body seals available as part code **TMAA22-07** - Spares Kit Body Seals.

1. Reconnect the control-head loom to the connector on the radio body. See Figure 3.2 above.
2. Align the control head with the front of the radio body. Ensure the control-head loom folds properly into the space between the control head and the radio body.
3. Press the control head against the radio body until it clips into position.

The most effective method noted has been to position the top of the control head over it's respective locating lugs and roll the head flat to clip the bottom into position.

Compliance Issues

None.

CSO Instruction

Inform all Technical staff and accredited dealers of the procedure detailed here.

