

# Aeromax OSD

The AEROMAX is a MINIM compatible multi-function OSD built to a spec from the team behind MWOSD.

As a direct result of feedback from issues with overheating, reliability and noisy images on the genuine and MinimOSD clones in popular use, they worked with one of the best suppliers in china to produce a new design to not only significantly reduce these issue, but also to provide additional hardware support and expansion growth for the future.

Recommended for use with BETAFLIGHT / CLEANFLIGHT / RACEFLIGHT and PX4/APM

There are many MinimOSD style clones out there – so why buy this one. What makes it worth the extra. Check out why:

## Key features:

- It's from the guys at MWOSD – probably the most popular OSD firmware in the world today
- Far **superior noise resistance** from power fluctuations
- Uses the **newest AB7456 chip** – generates far less heat and uses far less power than MAX7456 based clones
- Works down to less than 4v – VERY resilient to voltage fluctuations unlike normal MinimOSD clones which lock up
- Flat bottom form factor for **easy mounting** – Just some thick double sided tape
- Standard 0.1" servo pins – Easy and simple to connect
- Gold plated pin via – higher quality
- Extra hardware support - protect your investment in the future
- Direct **hardware support** for non-standard FRSKY RSSI such as **d4R-ii**

## Hardware Features:

- Updated MAX7456 compatible on-screen display IC
- Flicker free screen updates
- All the same features as the original – and more – and in a smaller package
- 35mm x 20mm size!
- 5V DC Supply that can tolerate up to 35v
- Regulated and filtered supply – less probability of display noise from power
- FTDI cable compatible pinout
- Two LED indicators
- Arduino bootloader – you can update this unlike some clones
- Supports direct monitoring of 2 batteries up to 6s without modification.
- Supports current sensor
- Supports Analog or Digital PWM RSSI signal. Also FRSKY D4R-ii - unlike clones
- Powered by Atmega 328P 16Mhz processor
- 3 wire camera / VTX connections – option to pass through power

# Aeromax OSD

## Connections:

- BAT1 - Main battery voltage monitoring (0-28v)
- BAT2 - Video battery voltage monitoring( 0-28v)
- RST - Reset (connect to ground to reset)
- CURR - Current sensor monitoring (0-5v)
- RSSI - RX RSSI sensor monitoring (0-5v Analogue or PWM)
- Vout - Video signal output to VTX
- Vin - Video signal input from Camera
- Vcam - Supply voltage between VTX and camera.
- 5V – Supply to / from board
- GND – Ground
- RX – Serial input to board
- TX – Serial output from board
- DTR – Serial reset for programming

## Solder pad functions:

- The FRSKY RSSI filter jumper pad enables the use of FRSKY high frequency RSSI signals from units such as the D4R-II. Enabling this permanently is recommended. Standard 50hx PWM RSSI is unaffected by this jumper. Additionally, Analogue RSSI usually benefits with smoother readings when enabled.
- VBAT1-VCAM jumper pad is used to link the main battery voltage connected from VBAT1 to the VCAM connections for the video in and out. This can be used to reduce wiring in some installations. Ensure connected items such as camera / VTX can operate on the full battery voltage if used.

## Product notes:

- This product is intended for DIY use
- A level of technical expertise is required to assemble, install, configure and use
- This is not a plug and play product
- Soldering may be required
- Not all cameras are compatible with OSD's - check for suitability
- No liabilities are assumed for its use, suitability of application or any consequence from its use of failure

### WARNING

- This OSD is designed to be powered by 5v only. It can sustain significantly more however connected peripherals may not.
- Any voltages greater than 5v should only be connected to BAT1 and BAT2 pins
- The VCAM pins for video in and out are connected together. This is to enable pass-through voltage, if required, to the camera. It does NOT reduce voltages to 5v or 12v.

### SOLDER PAD functions

- The FRSKY RSSI filter jumper pad enables the use of FRSKY high frequency RSSI signals from units such as the D4R-II. Enabling this permanently is recommended. Standard 50hx PWM RSSI is unaffected by this jumper. Additionally, Analogue RSSI usually benefits with smoother readings when enabled.
- VBAT1-VCAM jumper pad is used to link the main battery voltage connected from VBAT1 to the VCAM connections for the video in and out. This can be used to reduce wiring in some installations. Ensure connected items such as camera / VTX can operate on the full battery voltage if used.

# Aeromax OSD

BETAFLIGHT / CLEANFLIGHT / iNAV installation



## VirtualPilot AEROMAX OSD - MINIM OSD MWOSD

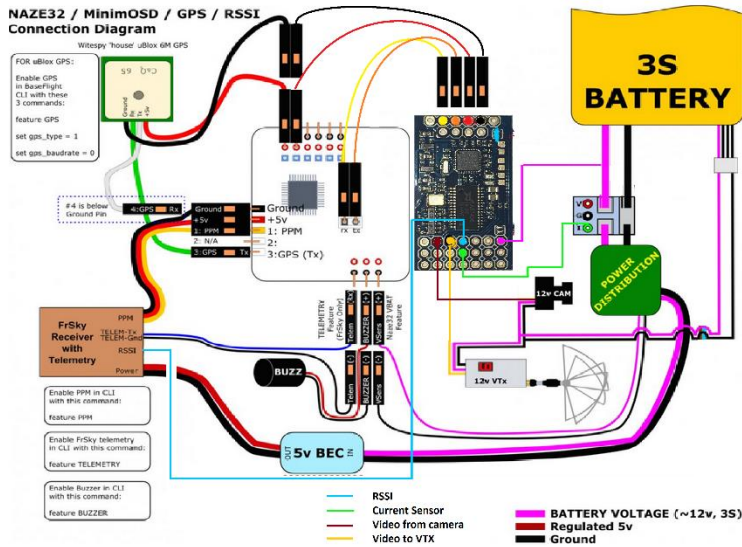

VirtualPilot AEROMAX OSD - MINIM OSD

**WARNING:**  
This OSD is designed to be powered by 5v only. It can sustain significantly more, however connected peripherals may not!  
Any voltages greater than 5v should only be connected to BAT1 and BAT2

**WARNING:**  
VCAM is connected between the video in and the out pins. This is to enable pass through voltage for supporting to cameras. It does NOT reduce voltages to 5v or 12v.

**SOLDER PAD FUNCTIONS**  
The FRISKY RSSI filter jumper pad enables the use of FRISKY high frequency RSSI rx units such as d4R-ii. Enabling this permanently is recommended. VBAT1-VCAM jumper pad is used to link the main battery voltage through to a camera that can run at that voltage. This is a useful feature to reduce wiring in certain setups. Ensure your camera can operate on the full battery voltage

- BAT1 Main battery voltage monitoring
- BAT2 Video battery voltage monitoring
- CURR Current sensor monitor
- RSSI RX RSSI monitor
- Vout Video out to VTX
- Vin Video in from Camera
- GND Ground
- 5V 5V Supply to power the OSD

Pins marked 5V and GND are linked between both ends of the board

This board is powered by the 5v supply only.

Higher voltages are not used to power the OSD in any way.

# Aeromax OSD

APM / PX4 installation

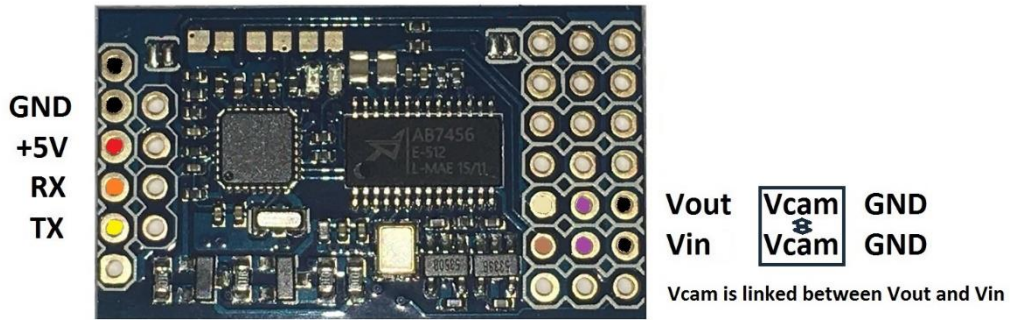

**VirtualPilot AEROMAX OSD - MINIM OSD** APM/PIXHAWK

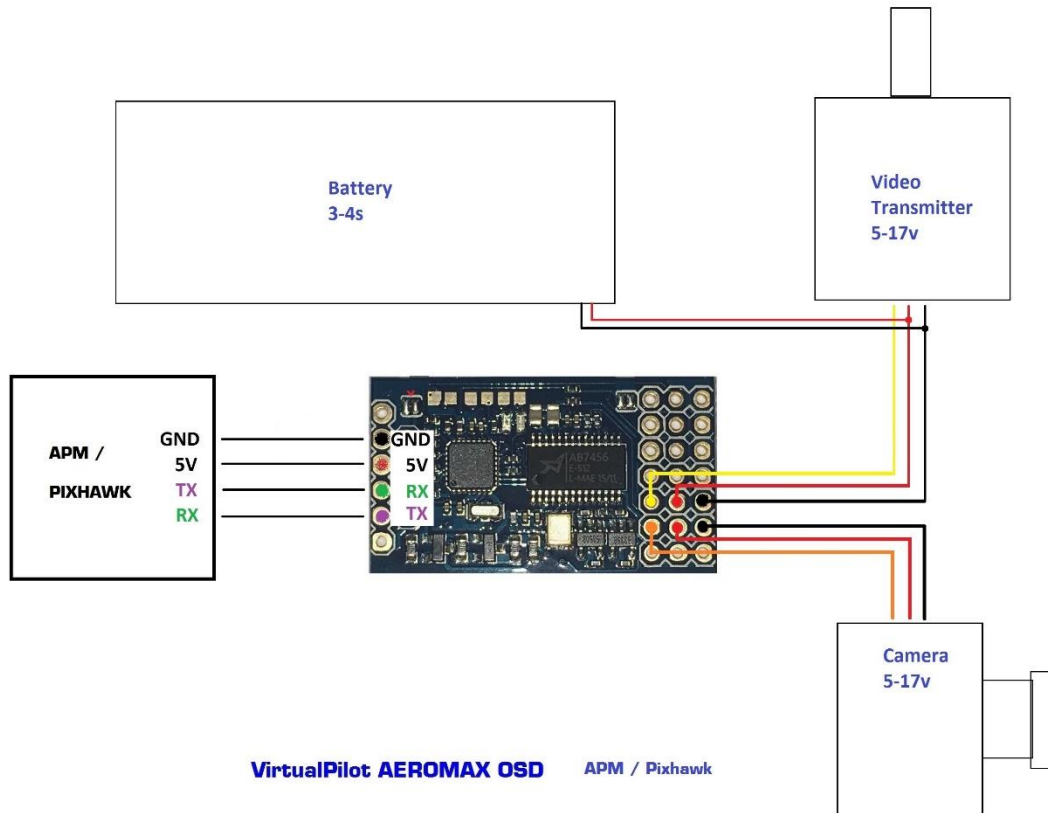

# Aeromax OSD

Standard GPS OSD – no flight controller

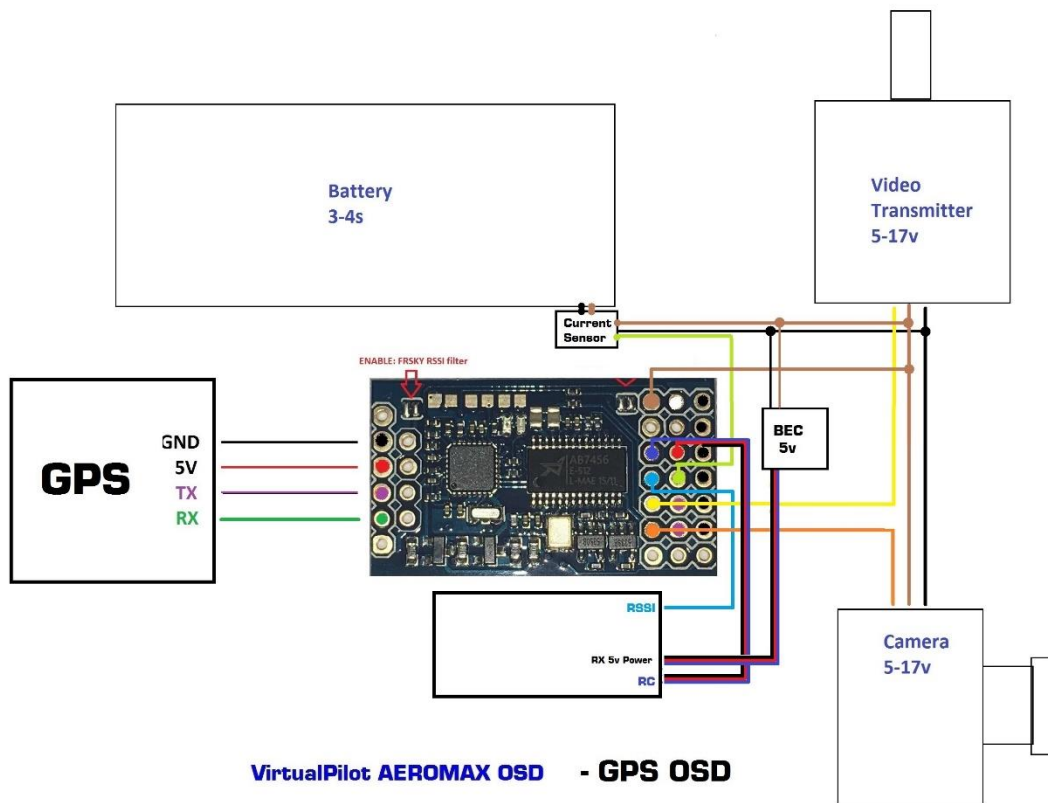

## Additional support for GPS OSD and DJI NAZA users:

- Additional PWM input available – use screen switching / PPM and RSSI simultaneously

# Aeromax OSD

## DJI Naza installation

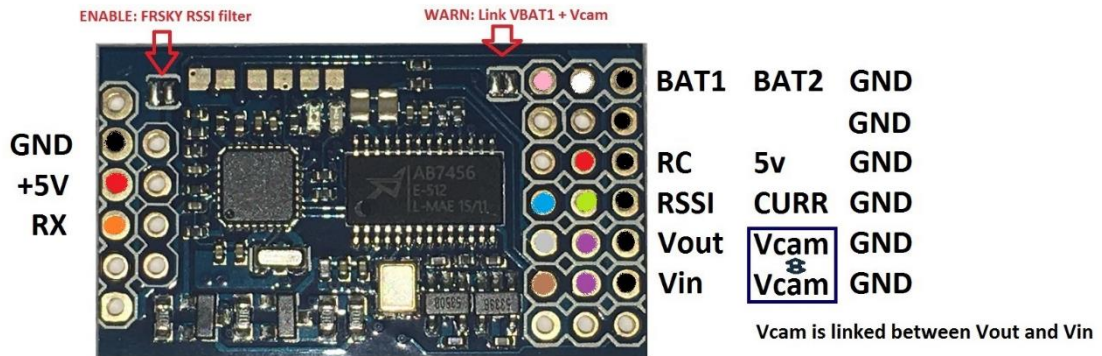

**VirtualPilot AEROMAX OSD** NAZA

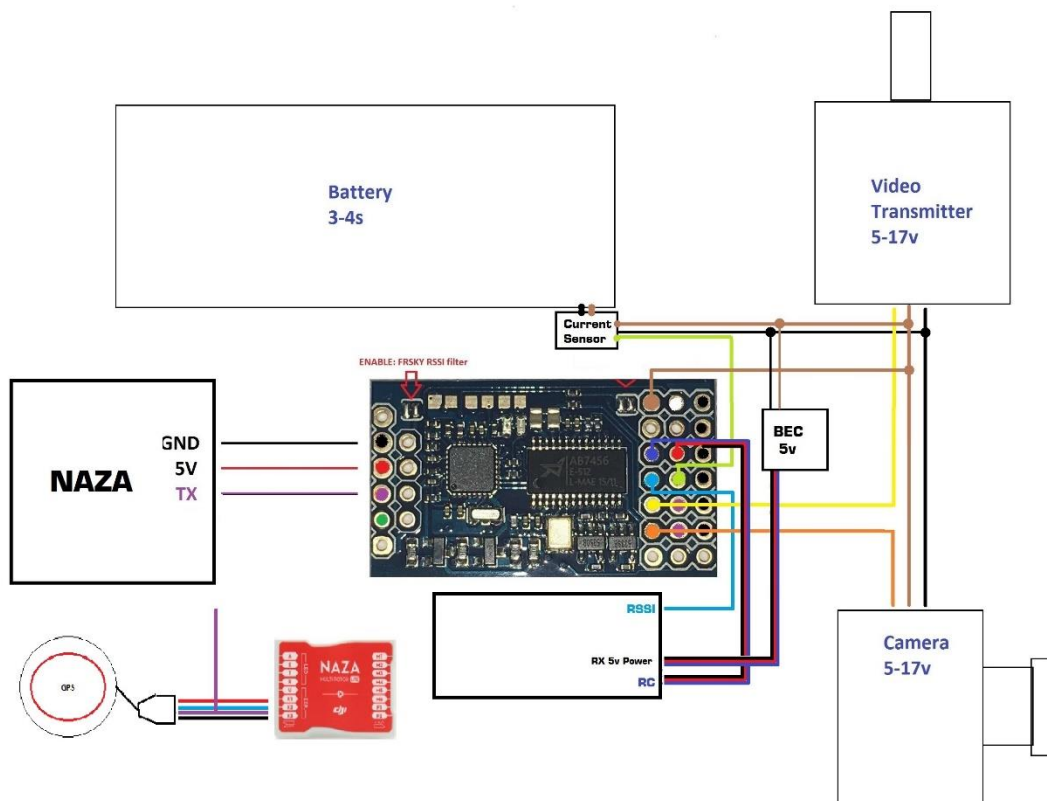

**VirtualPilot AEROMAX OSD** - NAZA

## Additional support for GPS OSD and DJI NAZA users:

# Aeromax OSD

- Additional PWM input available – use screen switching / PPM and RSSI simultaneously

## GPSOSD with vario for FPV thermal gliding



## FIRMWARE FLASHING connections

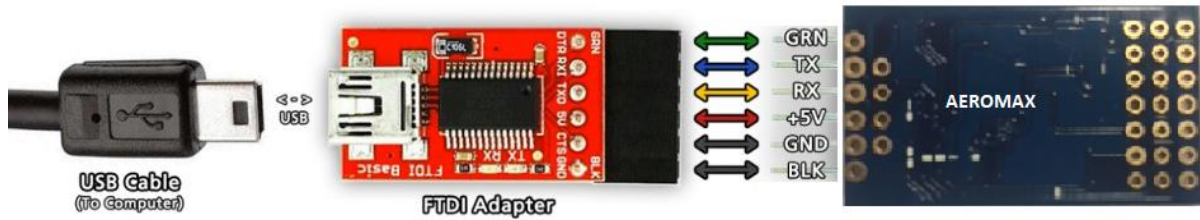

**IMPORTANT NOTE:** Connect ALL 6 pins for firmware flashing. Only center 4 are required for normal operation.