

FANUC Robot **series**

For Europe

R-30*i*A Mate CONTROLLER MAINTENANCE MANUAL

B-82725EN-1/07

- **Original Instructions**

Before using the Robot, be sure to read the "FANUC Robot Safety Manual (B-80687EN)" and understand the content.

- No part of this manual may be reproduced in any form.
- All specifications and designs are subject to change without notice.

The products in this manual are controlled based on Japan's "Foreign Exchange and Foreign Trade Law". The export from Japan may be subject to an export license by the government of Japan.

Further, re-export to another country may be subject to the license of the government of the country from where the product is re-exported. Furthermore, the product may also be controlled by re-export regulations of the United States government.

Should you wish to export or re-export these products, please contact FANUC for advice.

The products in this manual are manufactured under strict quality control. However, when using any of the products in a facility in which a serious accident or loss is predicted due to a failure of the product, install a safety device.

In this manual we have tried as much as possible to describe all the various matters.

However, we cannot describe all the matters which must not be done, or which cannot be done, because there are so many possibilities.

Therefore, matters which are not especially described as possible in this manual should be regarded as "impossible".

PREFACE

This manual describes the following models (R-30iA Mate controller).

Model	Abbreviation	
FANUC Robot LR Mate 200iC	LR Mate 200iC	LR Mate 200iC
FANUC Robot LR Mate 200iC/5C	LR Mate 200iC/5C	
FANUC Robot LR Mate 200iC/5F	LR Mate 200iC/5F	
FANUC Robot LR Mate 200iC/5H	LR Mate 200iC/5H	
FANUC Robot LR Mate 200iC/5L	LR Mate 200iC/5L	
FANUC Robot LR Mate 200iC/5LC	LR Mate 200iC/5LC	
FANUC Robot LR Mate 200iC/5WP	LR Mate 200iC/5WP	
FANUC Robot ARC Mate 100iC FANUC Robot ROBOWELD 100iC	ARC Mate 100iC	ARC Mate 100iC
FANUC Robot ARC Mate 100iC/6L FANUC ROBOWELD 100iC/6L	ARC Mate 100iC/6L	
FANUC Robot ARC Mate 100iCe FANUC Robot ARC Mate 100iCe/6L	ARC Mate 100iCe	
	ARC Mate 100iCe/6L	
FANUC Robot M-10iA FANUC Robot M-10iA/6L FANUC Robot M-10iAe FANUC Robot M-10iAe/6L	M-10iA M-10iA/6L M-10iAe M-10iAe/6L	M-10iA
FANUC Robot ARC Mate 120iC FANUC ROBOWELD 120iC FANUC Robot ARC Mate 120iC/10L FANUC ROBOWELD 120iC/10L	ARC Mate 120iC ARC Mate 120iC/10L	ARC Mate 120iC
FANUC Robot M-20iA FANUC Robot M-20iA/10L	M-20iA M-20iA/10L	M-20iA
FANUC Robot ARC Mate 50iC FANUC ROBOWELD Mini iC FANUC Robot ARC Mate 50iC/5L FANUC ROBOWELD Mini iC/5L	ARC Mate 50iC ARC Mate 50iC/5L	ARC Mate 50iC
FANUC Robot ARC Mate 0iA	ARC Mate 0iA	ARC Mate 0iA
FANUC Robot M-1iA/0.5A FANUC Robot M-1iA/0.5S	M-1iA/0.5A M-1iA/0.5S	M-1iA

SAFETY PRECAUTIONS

SAFETY PRECAUTIONS

For the safety of the operator and the system, follow all safety precautions when operating a robot and its peripheral devices installed in a work cell.

In addition, refer to the “FANUC Robot SAFETY HANDBOOK (B-80687EN)”.

1 WORKING PERSON

The personnel can be classified as follows.

Operator:

- Turns robot controller power ON/OFF
- Starts robot program from operator's panel

Programmer or teaching operator:

- Operates the robot
- Teaches robot inside the safety fence

Maintenance engineer:

- Operates the robot
- Teaches robot inside the safety fence
- Maintenance (adjustment, replacement)

- An operator cannot work inside the safety fence.
- A programmer, teaching operator, and maintenance engineer can work inside the safety fence. The working activities inside the safety fence include lifting, setting, teaching, adjusting, maintenance, etc..
- To work inside the fence, the person must be trained on proper robot operation.

During the operation, programming, and maintenance of your robotic system, the programmer, teaching operator, and maintenance engineer should take additional care of their safety by using the following safety precautions.

- Use adequate clothing or uniforms during system operation
- Wear safety shoes
- Use helmet

2 WORKING PERSON SAFETY

Working person safety is the primary safety consideration. Because it is very dangerous to enter the operating space of the robot during automatic operation, adequate safety precautions must be observed. The following lists the general safety precautions. Careful consideration must be made to ensure working person safety.

- (1) Have the robot system working persons attend the training courses held by FANUC.

FANUC provides various training courses. Contact our sales office for details.

- (2) Even when the robot is stationary, it is possible that the robot is still in a ready to move state, and is waiting for a signal. In this state, the robot is regarded as still in motion. To ensure working person safety, provide the system with an alarm to indicate visually or aurally that the robot is in motion.
- (3) Install a safety fence with a gate so that no working person can enter the work area without passing through the gate. Install an interlocking device, a safety plug, and so forth in the safety gate so that the robot is stopped as the safety gate is opened.

The controller is designed to receive this interlocking signal of the door switch. When the gate is opened and this signal received, the controller stops the robot (Please refer to "STOP TYPE OF ROBOT" in SAFETY for detail of stop type). For connection, see Fig.2 (a) and Fig.2 (b).

- (4) Provide the peripheral devices with appropriate grounding (Class A, Class B, Class C, and Class D).
- (5) Try to install the peripheral devices outside the work area.
- (6) Draw an outline on the floor, clearly indicating the range of the robot motion, including the tools such as a hand.
- (7) Install a mat switch or photoelectric switch on the floor with an interlock to a visual or aural alarm that stops the robot when a working person enters the work area.
- (8) If necessary, install a safety lock so that no one except the working person in charge can turn on the power of the robot.

The circuit breaker installed in the controller is designed to disable anyone from turning it on when it is locked with a padlock.

- (9) When adjusting each peripheral device independently, be sure to turn off the power of the robot

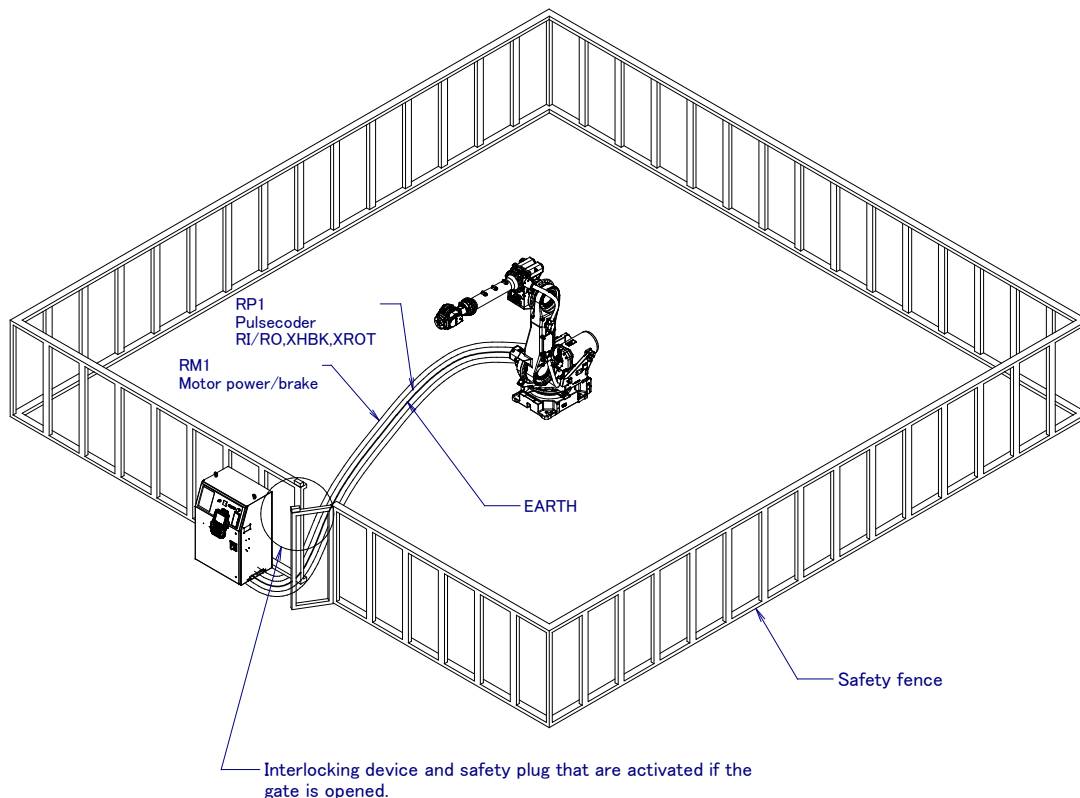


Fig.2 (a) Safety fence and safety gate

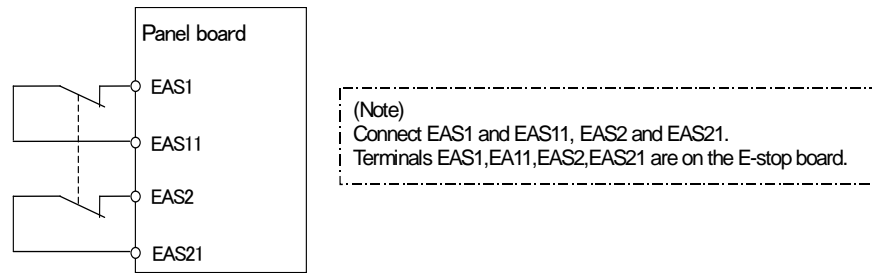


Fig.2 (b) Limit switch circuit diagram of the safety fence

2.1 OPERATOR SAFETY

The operator is a person who operates the robot system. In this sense, a worker who operates the teach pendant is also an operator. However, this section does not apply to teach pendant operators.

- (1) If you do not have to operate the robot, turn off the power of the robot controller or press the EMERGENCY STOP button, and then proceed with necessary work.
- (2) Operate the robot system at a location outside of the safety fence
- (3) Install a safety fence with a safety gate to prevent any worker other than the operator from entering the work area unexpectedly and to prevent the worker from entering a dangerous area.
- (4) Install an EMERGENCY STOP button within the operator's reach.

The robot controller is designed to be connected to an external EMERGENCY STOP button. With this connection, the controller stops the robot operation (Please refer to "STOP TYPE OF ROBOT" in SAFETY for detail of stop type), when the external EMERGENCY STOP button is pressed. See the diagram below for connection.

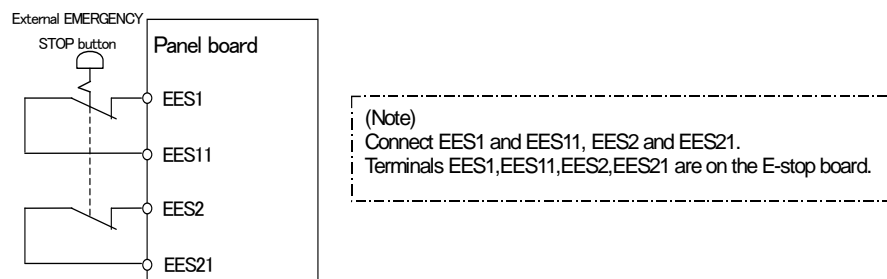


Fig.2.1 Connection diagram for external emergency stop button

2.2 SAFETY OF THE PROGRAMMER

While teaching the robot, the operator must enter the work area of the robot. The operator must ensure the safety of the teach pendant operator especially.

- (1) Unless it is specifically necessary to enter the robot work area, carry out all tasks outside the area.
- (2) Before teaching the robot, check that the robot and its peripheral devices are all in the normal operating condition.
- (3) If it is inevitable to enter the robot work area to teach the robot, check the locations, settings, and other conditions of the safety devices (such as the EMERGENCY STOP button, the DEADMAN switch on the teach pendant) before entering the area.
- (4) The programmer must be extremely careful not to let anyone else enter the robot work area.

The operator panel is provided with an emergency stop button and a key switch (mode switch) for selecting the automatic operation mode (AUTO) and the teach modes (T1 and T2). Before entering the inside of the safety fence for the purpose of teaching, set the switch to a teach mode, remove the key from the mode switch to prevent other people from changing the operation mode carelessly, then open the safety gate. If the safety gate is opened with the automatic operation mode set, the robot stops (Please refer to "STOP TYPE OF ROBOT" in SAFETY for detail of stop type). After the switch is set to a teach mode, the safety gate is disabled. The programmer should understand that the safety gate is disabled and is responsible for keeping other people from entering the inside of the safety fence.

The teach pendant is provided with a DEADMAN switch as well as an emergency stop button. These button and switch function as follows:

- (1) Emergency stop button: Causes an emergency stop (Please refer to "STOP TYPE OF ROBOT" in SAFETY for detail of stop type) when pressed.
- (2) DEADMAN switch: Functions differently depending on the mode switch setting status.
 - (a) Automatic operation mode: The DEADMAN switch is disabled.
 - (b) Teach mode: Servo power is turned off when the operator releases the DEADMAN switch or when the operator presses the switch strongly.

Note) The DEADMAN switch is provided to stop the robot when the operator releases the teach pendant or presses the pendant strongly in case of emergency. The R-30iA Mate employs a 3-position DEADMAN switch, which allows the robot to operate when the 3-position DEADMAN switch is pressed to its intermediate point. When the operator releases the DEADMAN switch or presses the switch strongly, the robot stops immediately.

The operator's intention of starting teaching is determined by the controller through the dual operation of setting the teach pendant enable/disable switch to the enable position and pressing the DEADMAN switch. The operator should make sure that the robot could operate in such conditions and be responsible in carrying out tasks safely.

The teach pendant, operator panel, and peripheral device interface send each robot start signal. However the validity of each signal changes as follows depending on the mode switch of the operator panel, the teach pendant enable/disable switch and the remote condition on the software.

Mode	Teach pendant enable/disable switch	Software remote condition	Teach pendant	Operator panel	Peripheral device
AUTO mode	On	Local	Not allowed	Not allowed	Not allowed
		Remote	Not allowed	Not allowed	Not allowed
	Off	Local	Not allowed	Allowed to start	Not allowed
		Remote	Not allowed	Not allowed	Allowed to start
T1, T2 mode	On	Local	Allowed to start	Not allowed	Not allowed
		Remote	Allowed to start	Not allowed	Not allowed
	Off	Local	Not allowed	Not allowed	Not allowed
		Remote	Not allowed	Not allowed	Not allowed

T1,T2 mode: DEADMAN switch is effective.

- (5) To start the system using the operator's panel, make certain that nobody is the robot work area and that there are no abnormal conditions in the robot work area.
- (6) When a program is completed, be sure to carry out a test run according to the procedure below.
 - (a) Run the program for at least one operation cycle in the single step mode at low speed.
 - (b) Run the program for at least one operation cycle in the continuous operation mode at low speed.
 - (c) Run the program for one operation cycle in the continuous operation mode at the intermediate speed and check that no abnormalities occur due to a delay in timing.
 - (d) Run the program for one operation cycle in the continuous operation mode at the normal operating speed and check that the system operates automatically without trouble.
 - (e) After checking the completeness of the program through the test run above, execute it in the automatic operation mode.

- (7) While operating the system in the automatic operation mode, the teach pendant operator should leave the robot work area.

2.3 SAFETY OF THE MAINTENANCE ENGINEER

For the safety of maintenance engineer personnel, pay utmost attention to the following.

- (1) During operation, never enter the robot work area.
- (2) Except when specifically necessary, turn off the power of the controller while carrying out maintenance. Lock the power switch, if necessary, so that no other person can turn it on.
- (3) If it becomes necessary to enter the robot operation range while the power is on, press the emergency stop button on the operator panel, or the teach pendant before entering the range. The maintenance personnel must indicate that maintenance work is in progress and be careful not to allow other people to operate the robot carelessly.
- (4) When disconnecting the pneumatic system, be sure to reduce the supply pressure.
- (5) Before the start of teaching, check that the robot and its peripheral devices are all in the normal operating condition.
- (6) Do not operate the robot in the automatic mode while anybody is in the robot work area.
- (7) When you maintain the robot alongside a wall or instrument, or when multiple workers are working nearby, make certain that their escape path is not obstructed.
- (8) When a tool is mounted on the robot, or when any moving device other than the robot is installed, such as belt conveyor, pay careful attention to its motion.
- (9) If necessary, have a worker who is familiar with the robot system stand beside the operator panel and observe the work being performed. If any danger arises, the worker should be ready to press the EMERGENCY STOP button at any time.
- (10) When replacing or reinstalling components, take care to prevent foreign matter from entering the system.
- (11) When handling each unit or printed circuit board in the controller during inspection, turn off the circuit breaker to protect against electric shock.
If there are two cabinets, turn off the both circuit breaker.
- (12) When replacing parts, be sure to use those specified by FANUC.
In particular, never use fuses or other parts of non-specified ratings. They may cause a fire or result in damage to the components in the controller.
- (13) When restarting the robot system after completing maintenance work, make sure in advance that there is no person in the work area and that the robot and the peripheral devices are not abnormal.

3 SAFETY OF THE TOOLS AND PERIPHERAL DEVICES

3.1 PRECAUTIONS IN PROGRAMMING

- (1) Use a limit switch or other sensor to detect a dangerous condition and, if necessary, design the program to stop the robot when the sensor signal is received.
- (2) Design the program to stop the robot when an abnormal condition occurs in any other robots or peripheral devices, even though the robot itself is normal.
- (3) For a system in which the robot and its peripheral devices are in synchronous motion, particular care must be taken in programming so that they do not interfere with each other.
- (4) Provide a suitable interface between the robot and its peripheral devices so that the robot can detect the states of all devices in the system and can be stopped according to the states.

3.2 PRECAUTIONS FOR MECHANISM

- (1) Keep the component cells of the robot system clean, and operate the robot in an environment free of grease, water, and dust.
- (2) Don't use unconfirmed liquid for cutting fluid and cleaning fluid.
- (3) Employ a limit switch or mechanical stopper to limit the robot motion so that the robot or cable does not strike against its peripheral devices or tools.
- (4) Observe the following precautions about the mechanical unit cables. When these attentions are not kept, unexpected troubles might occur.
 - Use mechanical unit cable that have required user interface.
 - Don't add user cable or hose to inside of mechanical unit.
 - Please do not obstruct the movement of the mechanical unit cable when cables are added to outside of mechanical unit.
 - In the case of the model that a cable is exposed, Please do not perform remodeling (Adding a protective cover and fix an outside cable more) obstructing the behavior of the outcrop of the cable.
 - Please do not interfere with the other parts of mechanical unit when install equipments in the robot.
- (5) The frequent power-off stop for the robot during operation causes the trouble of the robot. Please avoid the system construction that power-off stop would be operated routinely. (Refer to bad case example.) Please execute power-off stop after reducing the speed of the robot and stopping it by hold stop or cycle stop when it is not urgent. (Please refer to "STOP TYPE OF ROBOT" in SAFETY for detail of stop type.)

(Bad case example)

 - Whenever poor product is generated, a line stops by emergency stop.
 - When alteration was necessary, safety switch is operated by opening safety fence and power-off stop is executed for the robot during operation.
 - An operator pushes the emergency stop button frequently, and a line stops.
 - An area sensor or a mat switch connected to safety signal operate routinely and power-off stop is executed for the robot.
- (6) Robot stops urgently when collision detection alarm (SV050) etc. occurs. The frequent urgent stop by alarm causes the trouble of the robot, too. So remove the causes of the alarm.

4 SAFETY OF THE ROBOT MECHANISM

4.1 PRECAUTIONS IN OPERATION

- (1) When operating the robot in the jog mode, set it at an appropriate speed so that the operator can manage the robot in any eventuality.
- (2) Before pressing the jog key, be sure you know in advance what motion the robot will perform in the jog mode.

4.2 PRECAUTIONS IN PROGRAMMING

- (1) When the work areas of robots overlap, make certain that the motions of the robots do not interfere with each other.
- (2) Be sure to specify the predetermined work origin in a motion program for the robot and program the motion so that it starts from the origin and terminates at the origin.
Make it possible for the operator to easily distinguish at a glance that the robot motion has terminated.

4.3 PRECAUTIONS FOR MECHANISMS

- (1) Keep the work areas of the robot clean, and operate the robot in an environment free of grease, water, and dust.

4.4 PROCEDURE TO MOVE ARM WITHOUT DRIVE POWER IN EMERGENCY OR ABNORMAL SITUATIONS

For emergency or abnormal situations (e.g. persons trapped in or by the robot), brake release unit can be used to move the robot axes without drive power.

Please refer to this manual and mechanical unit operator's manual for using method of brake release unit and method of supporting robot.

5 SAFETY OF THE END EFFECTOR

5.1 PRECAUTIONS IN PROGRAMMING

- (1) To control the pneumatic, hydraulic and electric actuators, carefully consider the necessary time delay after issuing each control command up to actual motion and ensure safe control.
- (2) Provide the end effector with a limit switch, and control the robot system by monitoring the state of the end effector.

6 STOP TYPE OF ROBOT

The following three robot stop types exist:

Power-Off Stop (Category 0 following IEC 60204-1)

Servo power is turned off and the robot stops immediately. Servo power is turned off when the robot is moving, and the motion path of the deceleration is uncontrolled.

The following processing is performed at Power-Off stop.

- An alarm is generated and servo power is turned off.
- The robot operation is stopped immediately. Execution of the program is paused.

Controlled stop (Category 1 following IEC 60204-1)

The robot is decelerated until it stops, and servo power is turned off.

The following processing is performed at Controlled stop.

- The alarm "SRVO-199 Controlled stop" occurs along with a decelerated stop. Execution of the program is paused.
- An alarm is generated and servo power is turned off.

Hold (Category 2 following IEC 60204-1)

The robot is decelerated until it stops, and servo power remains on.

The following processing is performed at Hold.

- The robot operation is decelerated until it stops. Execution of the program is paused.

⚠ WARNING

The stopping distance and stopping time of Controlled stop are longer than the stopping distance and stopping time of Power-Off stop. A risk assessment for the whole robot system, which takes into consideration the increased stopping distance and stopping time, is necessary when Controlled stop is used.

When the E-Stop button is pressed or the FENCE is open, the stop type of robot is Power-Off stop or Controlled stop. The configuration of stop type for each situation is called *stop pattern*. The stop pattern is different according to the controller type or option configuration.

There are the following 3 Stop patterns.

Stop pattern	Mode	E-Stop button	External E-Stop	FENCE open
A	AUTO	P-Stop	P-Stop	C-Stop
	T1	P-Stop	P-Stop	DEADMAN-sw.
	T2	P-Stop	P-Stop	DEADMAN-sw.
B	AUTO	P-Stop	P-Stop	P-Stop
	T1	P-Stop	P-Stop	DEADMAN-sw.
	T2	P-Stop	P-Stop	DEADMAN-sw.
C	AUTO	C-Stop	C-Stop	C-Stop
	T1	P-Stop	P-Stop	DEADMAN-sw.
	T2	P-Stop	P-Stop	DEADMAN-sw.

P-Stop: Power-Off stop

C-Stop: Controlled stop

DEADMAN-sw.: Power-Off stop when the operator releases the DEADMAN switch or when the operator presses the switch strongly.

⚠ WARNING

In this manual, the term "Emergency-stop" is used for the stop by above safety signals. Please refer to above table for actual stop type.

The following table indicates the Stop pattern according to the controller type or option configuration.

Option	RIA type	CE type
Standard	A	A
Stop type set (Stop pattern C)	C	C

The stop pattern of the controller is displayed in "Stop pattern" line in software version screen. Please refer "Software version" in operator's manual of controller for the detail of software version screen.

"Stop type set (Stop pattern C)" option

"Stop type set (Stop pattern C)" is an optional function. When this option is loaded, the stop type of the following alarms becomes Controlled stop but only in AUTO mode. In T1 or T2 mode, the stop type is Power-Off stop which is the normal operation of the system.

Alarm	Condition
SRVO-001 Operator panel E-stop	Operator panel E-stop is pressed.
SRVO-002 Teach pendant E-stop	Teach pendant E-stop is pressed.
SRVO-218 Ext.E-stop/Servo Disconnect	External emergency stop input (EES1-EES11, EES2-EES21) is open.
SRVO-408 DCS SSO Ext Emergency Stop	In DCS Safe I/O connect function, SSO[3] is OFF.
SRVO-409 DCS SSO Servo Disconnect	In DCS Safe I/O connect function, SSO[4] is OFF.

Controlled stop is different from Power-Off stop as follows:

- In Controlled stop, the robot is stopped on the program path. This function is effective for a system where the robot can interfere with other devices if it deviates from the program path.
- In Controlled stop, physical impact is less than Power-Off stop. This function is effective for systems where the physical impact to the mechanical unit or EOAT (End Of Arm Tool) should be minimized.
- The stopping distance and stopping time of Controlled stop is longer than the stopping distance and stopping time of Power-Off stop, depending on the robot model and axis. Please refer the operator's manual of a particular robot model for the data of stopping distance and stopping time.

This function is available only in CE or RIA type hardware.

When this option is loaded, this function can not be disabled.

The stop type of DCS Position and Speed Check functions is not affected by the loading of this option.



WARNING

The stopping distance and stopping time of Controlled stop are longer than the stopping distance and stopping time of Power-Off stop. A risk assessment for the whole robot system, which takes into consideration the increased stopping distance and stopping time, is necessary when this option is loaded.

7 **WARNING LABEL**

- (1) Step-on prohibitive label



Fig.7 (a) Step-on prohibitive label

Description

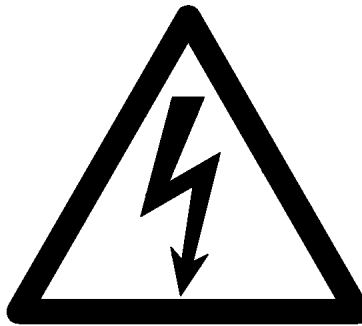
Do not step on or climb the robot or controller as it may adversely affect the robot or controller and you may get hurt if you lose your footing.

(2) High-temperature warning label

**Fig.7 (b) High-temperature warning label****Description**

Be cautious about a section where this label is affixed, as the section generates heat. If you must touch such a section when it is hot, use a protective provision such as heat-resistant gloves.

(3) High-voltage warning label

**Fig.7 (c) High-voltage warning label****Description**

A high voltage is applied to the places where this label is attached. Before starting maintenance, turn the power to the controller off, and turn the circuit breaker off to avoid electric shock hazards. Take additional precautions with the servo amplifier and other equipment, because high-voltage remains in these units for a certain amounts of time

TABLE OF CONTENTS

PREFACE	p-1
SAFETY PRECAUTIONS	s-1
I. MAINTENANCE	
1 OVERVIEW	3
2 CONFIGURATION	4
2.1 EXTERNAL VIEW OF THE CONTROLLER	4
2.2 COMPONENT FUNCTIONS.....	11
2.3 PREVENTIVE MAINTENANCE	11
3 TROUBLESHOOTING	13
3.1 POWER CANNOT BE TURNED ON	13
3.1.1 When the Teach Pendant Cannot be Powered on.....	13
3.1.2 When the Teach Pendant Does Not Change from the Initial Screen.....	14
3.2 ALARM OCCURRENCE SCREEN	15
3.3 SAFETY SIGNALS	18
3.4 MASTERING	19
3.5 TROUBLESHOOTING USING THE ERROR CODE	21
3.6 FUSE-BASED TROUBLESHOOTING	65
3.7 TROUBLESHOOTING BASED ON LED INDICATIONS	69
3.8 CHECK AND REPLACEMENT SURGE ABSORBER	76
3.9 POSITION DEVIATION FOUND IN RETURN TO THE REFERENCE POSITION (POSITIONING).....	77
3.10 MANUAL OPERATION IMPOSSIBLE	77
4 PRINTED CIRCUIT BOARDS	79
4.1 MAIN BOARD (A20B-8200-0470).....	79
4.2 EMERGENCY STOP CONTROL BOARD (A20B-2004-0290)	82
4.3 BACKPLANE BOARD (A20B-8101-0580)	83
4.4 PROCESS I/O BOARD MA (A20B-2004-0380)	84
4.5 PROCESS I/O BOARD MB (A20B-2101-0730)	85
4.6 CONNECTOR CONVERTER BOARD (A20B-2004-0410)	86
5 SERVO AMPLIFIERS	87
5.1 LED OF SERVO AMPLIFIER	88
5.2 SETTING OF SERVO AMPLIFIER.....	89
6 SETTING THE POWER SUPPLY	90
6.1 BLOCK DIAGRAM OF THE POWER SUPPLY	90
6.2 CHECKING THE POWER SUPPLY	91
7 REPLACING A UNIT	92
7.1 REPLACING THE PRINTED-CIRCUIT BOARDS	92
7.1.1 Replacing the Backplane Board (Unit).....	92

7.1.2	Replacing the Main board	93
7.2	REPLACING CARDS AND MODULES ON THE MAIN BOARD	94
7.3	REPLACING THE REGENERATIVE RESISTOR UNIT	100
7.4	REPLACING THE E-STOP UNIT	103
7.5	REPLACING SERVO AMPLIFIERS	104
7.6	REPLACING THE TEACH PENDANT and <i>i</i> PENDANT	106
7.7	REPLACING THE CONTROL SECTION FAN MOTOR	107
7.8	REPLACING THE AC FAN MOTOR	108
7.8.1	Replacing External Air Fan Unit and Door Fan	108
7.9	REPLACING FUSES	110
7.9.1	Replacing Fuses in the Servo Amplifier	110
7.9.2	Replacing Fuses in the Main board	111
7.9.3	Replacing the Fuse on the E-stop Boards	112
7.10	REPLACING RELAYS	113
7.10.1	Replacing Relays on the E-stop Board	113
7.11	REPLACING BATTERY	114
7.11.1	Battery for Memory Backup (3 VDC)	114

II. CONNECTIONS

1	GENERAL	119
2	BLOCK DIAGRAM	120
3	ELECTRICAL CONNECTIONS.....	121
3.1	CONNECTION DIAGRAM BETWEEN MECHANICAL UNITS	121
3.2	FANUC I/O LINK.....	123
3.2.1	Connection of I/O Link	123
3.2.2	Connection of I/O the Link Cable	124
3.3	EXTERNAL CABLE WIRING DIAGRAM	126
3.3.1	Robot Connection Cables	126
3.3.2	Teach Pendant Cable	127
3.3.3	Connecting the Input Power Supply	128
3.3.4	Connecting the External Emergency Stop	129
3.3.5	Connecting the Auxiliary Axis Brake (CRR65 A/B)	137
3.3.6	Connecting the Auxiliary Axis over Travel (CRM68)	138
4	PERIPHERAL DEVICE AND END EFFECTOR INTERFACES.....	139
4.1	PERIPHERAL DEVICE INTERFACE BLOCK DIAGRAM.....	141
4.1.1	In Case of Main Board (CRMA15, CRMA16)	141
4.1.2	In the Case of the Process I/O Board MA	142
4.1.3	In the Case of the Process I/O Board MB	142
4.1.4	In the Case of the Connector Conversion Board	143
4.2	I/O SIGNALS OF MAIN BOARD.....	143
4.3	INTERFACE FOR PERIPHERAL DEVICES.....	145
4.3.1	Connection between the Main Board (CRMA15, CRMA16) and Peripheral Devices	145
4.3.2	Connection between the Process I/O Board MA and Peripheral Devices.....	152
4.3.3	Connection between the Connector Conversion Board and Peripheral Devices..	156
4.3.4	Connection between the Process I/O Board MB and Welding Machines	157
4.4	INTERFACE FOR END EFFECTOR	159
4.4.1	Connection between the LR Mate 200iC, ARC Mate 50iC and End Effector	159

4.4.2	Connection between the ARC Mate 100iC/M-10iA, ARC Mate 120iC/M-20iA, ARC Mate 0iA and End Effector	160
4.5	DIGITAL I/O SIGNAL SPECIFICATIONS	162
4.5.1	Peripheral Device Interface	162
4.5.2	End Effector Control Interface	164
4.5.3	Specification for Arc Welding Machine Interface Input/Output Signals	165
4.6	SPECIFICATIONS OF THE CABLES USED FOR PERIPHERAL DEVICES AND WELDERS	168
4.6.1	Peripheral Device Interface A1 Cable (CRMA15: Tyco Electronics AMP, D-1000 series, 40 pins).....	168
4.6.2	Peripheral Device Interface A2 Cable (CRMA16: Tyco Electronics AMP, D-1000 series, 40 pins).....	168
4.6.3	Peripheral Device Interface B1 and B2 Cables (CRMA52; Tyco Electronics AMP K.K. 30 pin).....	169
4.6.4	ARC Weld Connection Cables (CRW11; Tyco Electronics AMP K.K. 20 pin)	169
4.7	CABLE CONNECTION FOR THE PERIPHERAL DEVICES	170
4.7.1	Peripheral Device Connection Cable.....	170
4.7.2	Peripheral Device Cable Connector	171
4.7.3	Recommended Cables	173
4.8	CONNECTING THE COMMUNICATION UNIT	174
4.8.1	RS-232-C Interface.....	174
4.8.1.1	Interface	174
4.8.1.2	RS-232-C interface signals	175
4.8.1.3	Connection between RS-232-C interface and I/O device	176
4.8.2	Ethernet Interface	178
4.8.2.1	Connection to Ethernet	178
4.8.2.2	Leading out the Ethernet cable	179
4.8.2.3	100BASE-TX connector (CD38R) pin assignments	179
4.8.2.4	Twisted-pair cable specification	180
4.8.2.5	Electrical noise countermeasures.....	183
4.8.2.6	Check items at installation.....	186
5	TRANSPORTATION AND INSTALLATION	187
5.1	TRANSPORTATION.....	187
5.2	INSTALLATION	188
5.2.1	Installation Method.....	188
5.3	MOUNTING METHOD OF TEACH PENDANT HOOK.....	191
5.4	INSTALLATION CONDITION	192
5.5	ADJUSTMENT AND CHECKS AT INSTALLATION	193
5.6	RESETTING OVERTRAVEL AND EMERGENCY STOP AT INSTALLATION	193
5.6.1	Peripheral Device Interface Processing.....	194
5.6.2	Resetting Overtravel.....	194
5.6.3	How to Disable/Enable HBK	194
5.6.4	How to Disable/Enable Pneumatic Pressure Alarm (PPABN).....	195
 APPENDIX		
A	TOTAL CONNECTION DIAGRAM.....	199
B	BRAKE RELEASE UNIT.....	217
B.1	SAFETY PRECAUTIONS	217

B.2	CONFIRMATIONS BEFORE OPERATION	217
B.3	OPERATION.....	218
B.4	HOW TO CONNECT THE PLUG TO THE POWER CABLE (IN CASE OF NO POWER PLUG)	221
B.5	DIMENSION	222
B.6	FUSE	224
B.7	SPECIFICATIONS.....	224

I. MAINTENANCE

1 OVERVIEW

This manual describes the maintenance and connection of the R-30*i*A Mate robot controller (called the R-30*i*A Mate).

Maintenance Part:

Troubleshooting, and the setting, adjustment, and replacement of units

Connection Part:

Connection of the R-30*i*A Mate controller to the robot mechanical unit and peripheral devices, and installation of the controller



WARNING

Before you enter the robot working area, be sure to turn off the power to the controller or press the EMERGENCY STOP button on the operator's panel or teach pendant.

Otherwise, you could injure personnel or damage equipment.

2 CONFIGURATION

2.1 EXTERNAL VIEW OF THE CONTROLLER

The appearance and components might slightly differ depending on the controlled robot, application, and options used.

Fig.2.1 (a) shows the view of R-30iA Mate.

Fig.2.1 (b) to (d) show the construction of the R-30iA Mate controller.

Fig.2.1 (e) to (g) show the external view of the operator's panel.

Fig.2.1 (h) to (i) show the block diagram of R-30iA Mate.

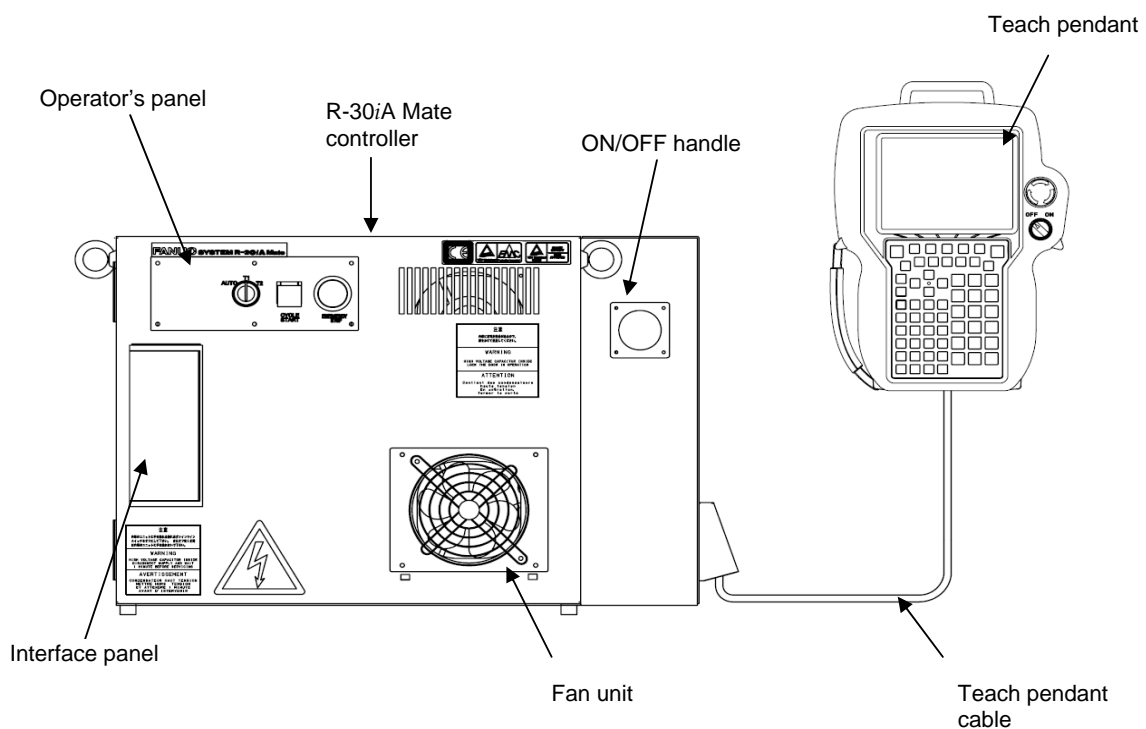


Fig.2.1 (a) External view of the R-30iA Mate controller

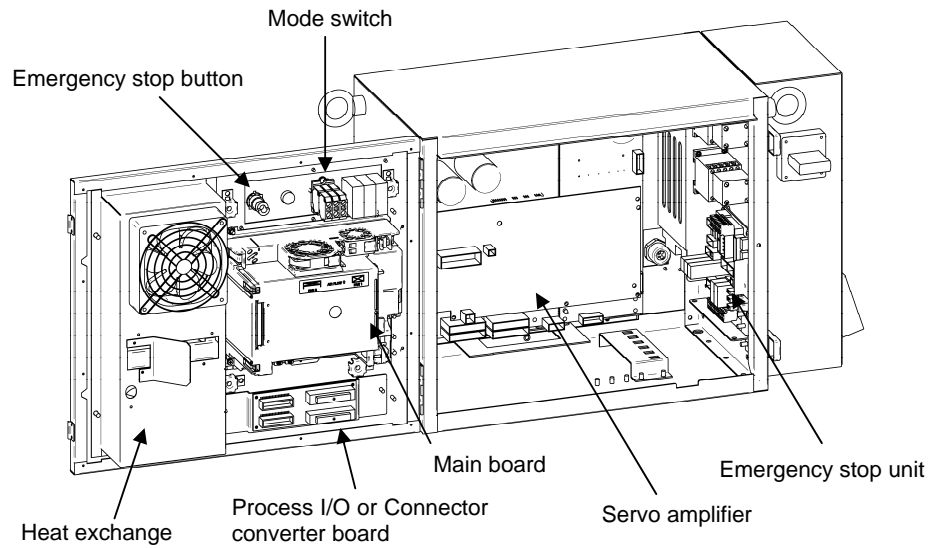
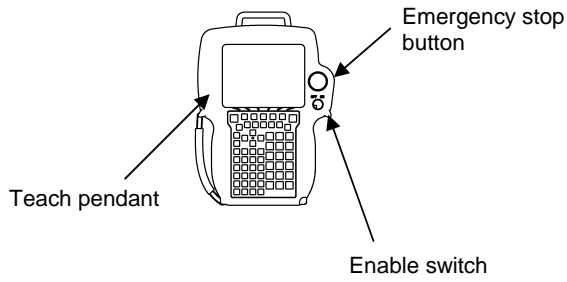


Fig.2.1 (b) R-30iA Mate interior (Front)

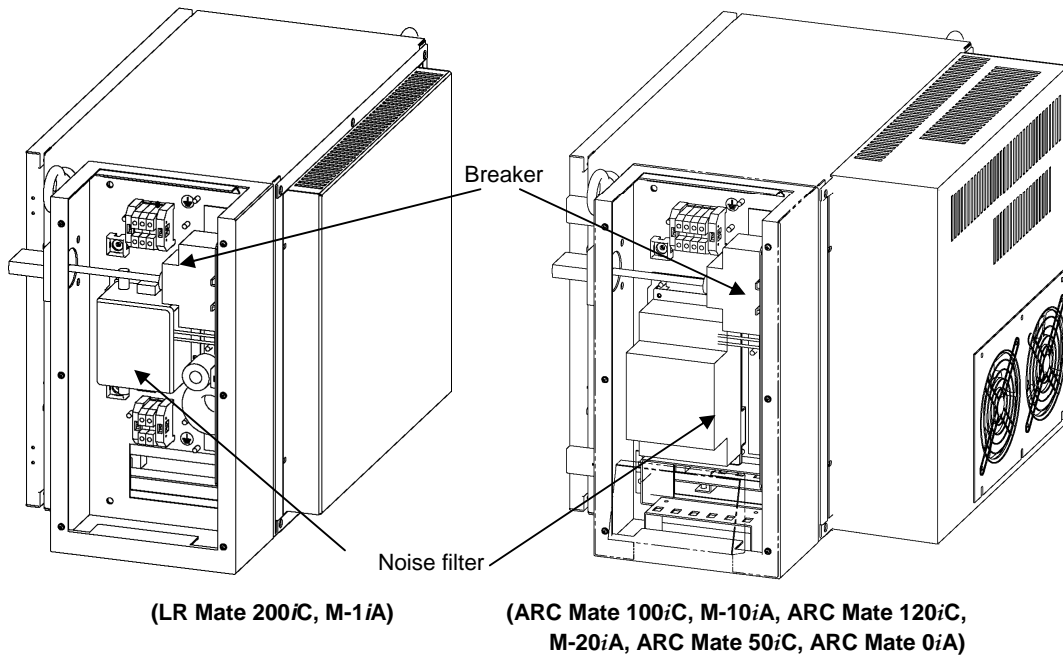


Fig.2.1 (c) R-30iA Mate interior (Side)

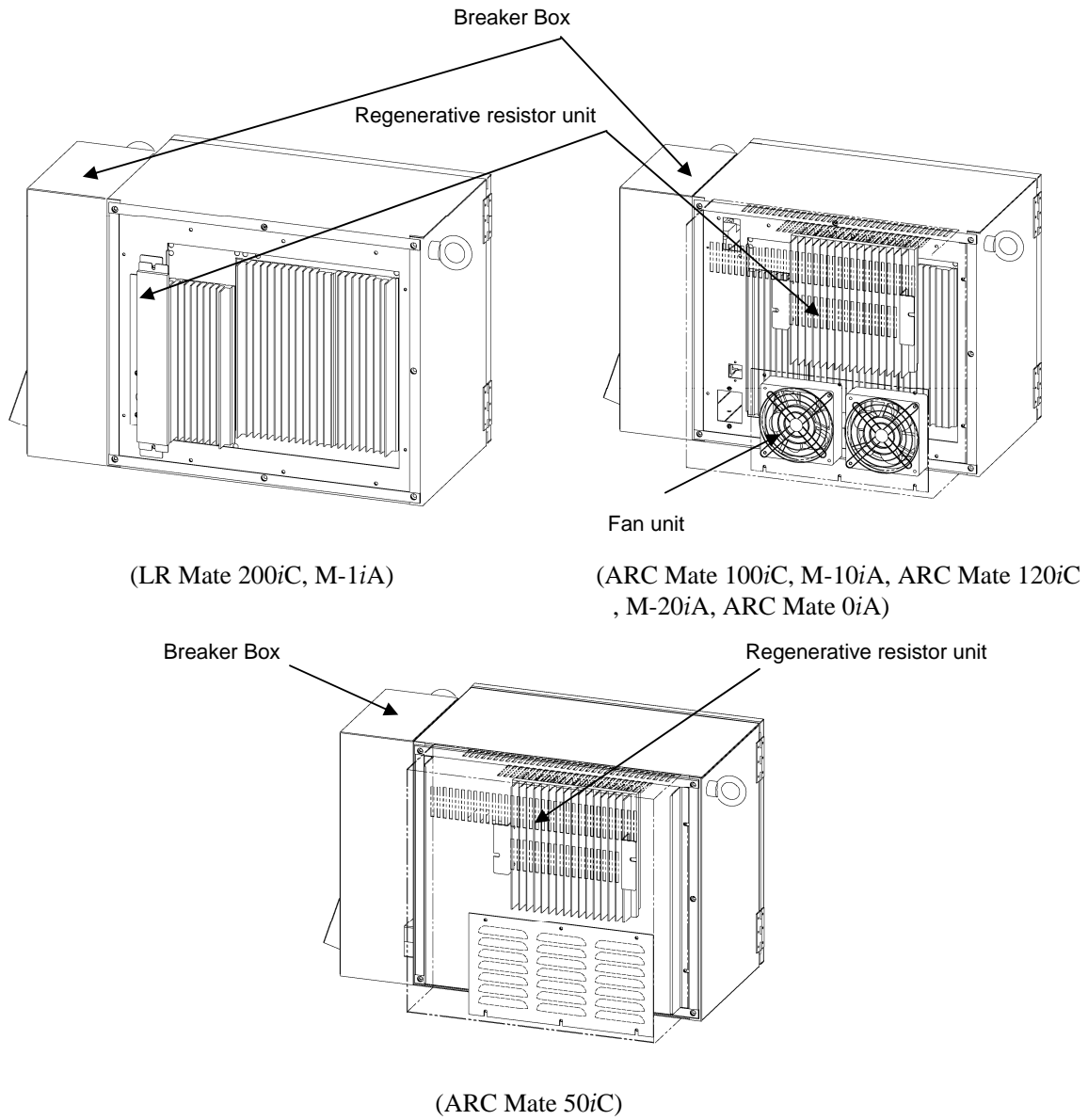


Fig.2.1 (d) R-30iA Mate interior

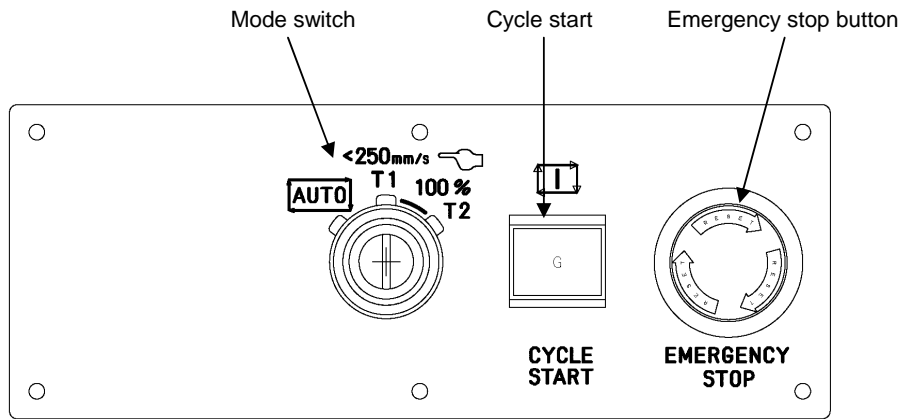


Fig.2.1 (e) R-30iA Mate panel overview

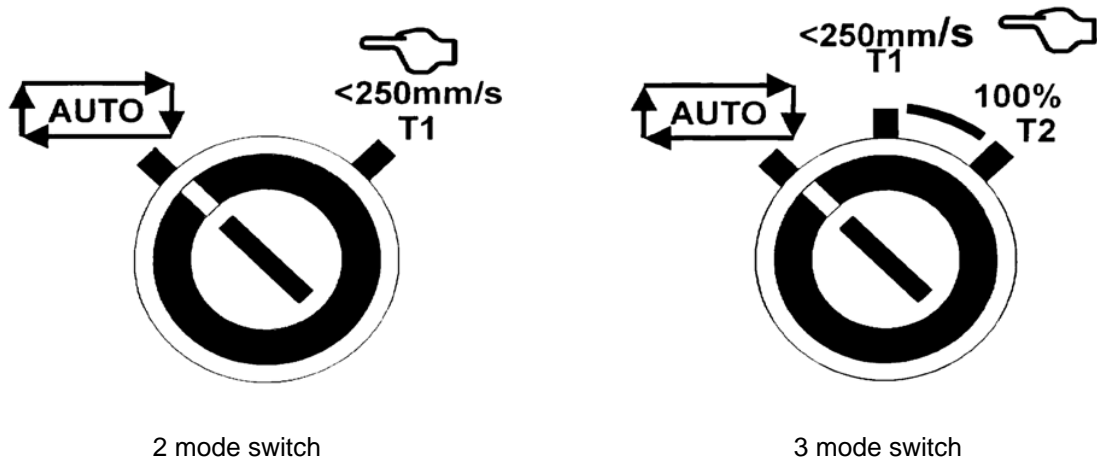


Fig.2.1 (f) Mode switch operation

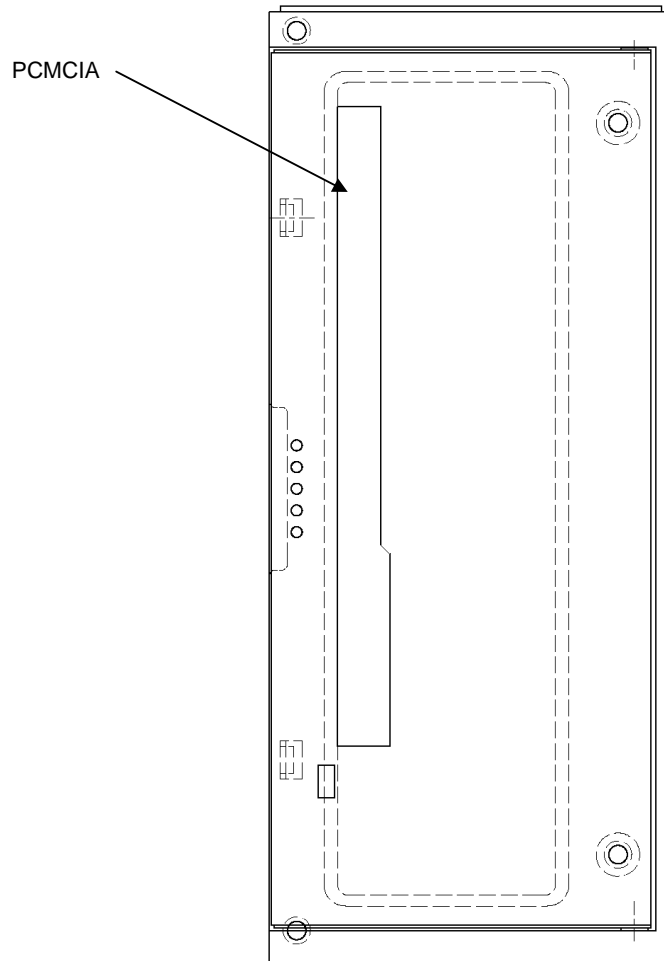


Fig.2.1 (g) interface overview

Table 2.1 Servo amplifier specifications

ROBOT	SERVO AMPLIFIER	REGENERATIVE RESISTOR
LR Mate 200iC	A06B-6107-H005	A05B-2550-C050
M-1iA	A06B-6107-H005	A05B-2550-C050
ARC Mate 50iC	A06B-6107-H005	A05B-2550-C051
ARC Mate 100iC, M-10iA ARC Mate 0iA	A06B-6107-H004	A05B-2550-C051
ARC Mate 100iCe, M-10iAe	A06B-6107-H004	A05B-2550-C053
ARC Mate 120iC, M-20iA	A06B-6107-H002	A05B-2550-C052

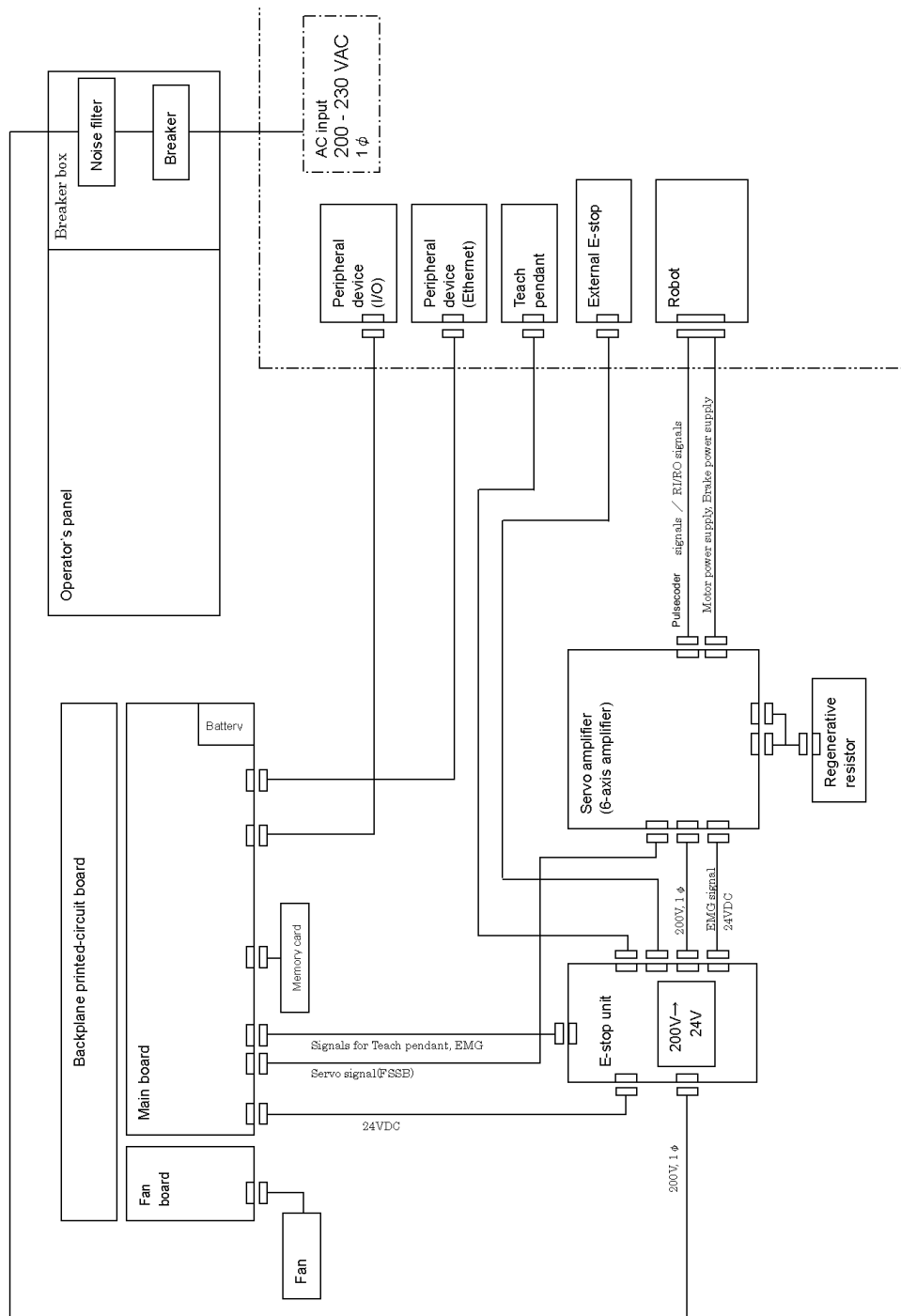


Fig.2.1 (h) Block diagram of the R-30iA Mate (LR Mate 200iC, M-1iA)

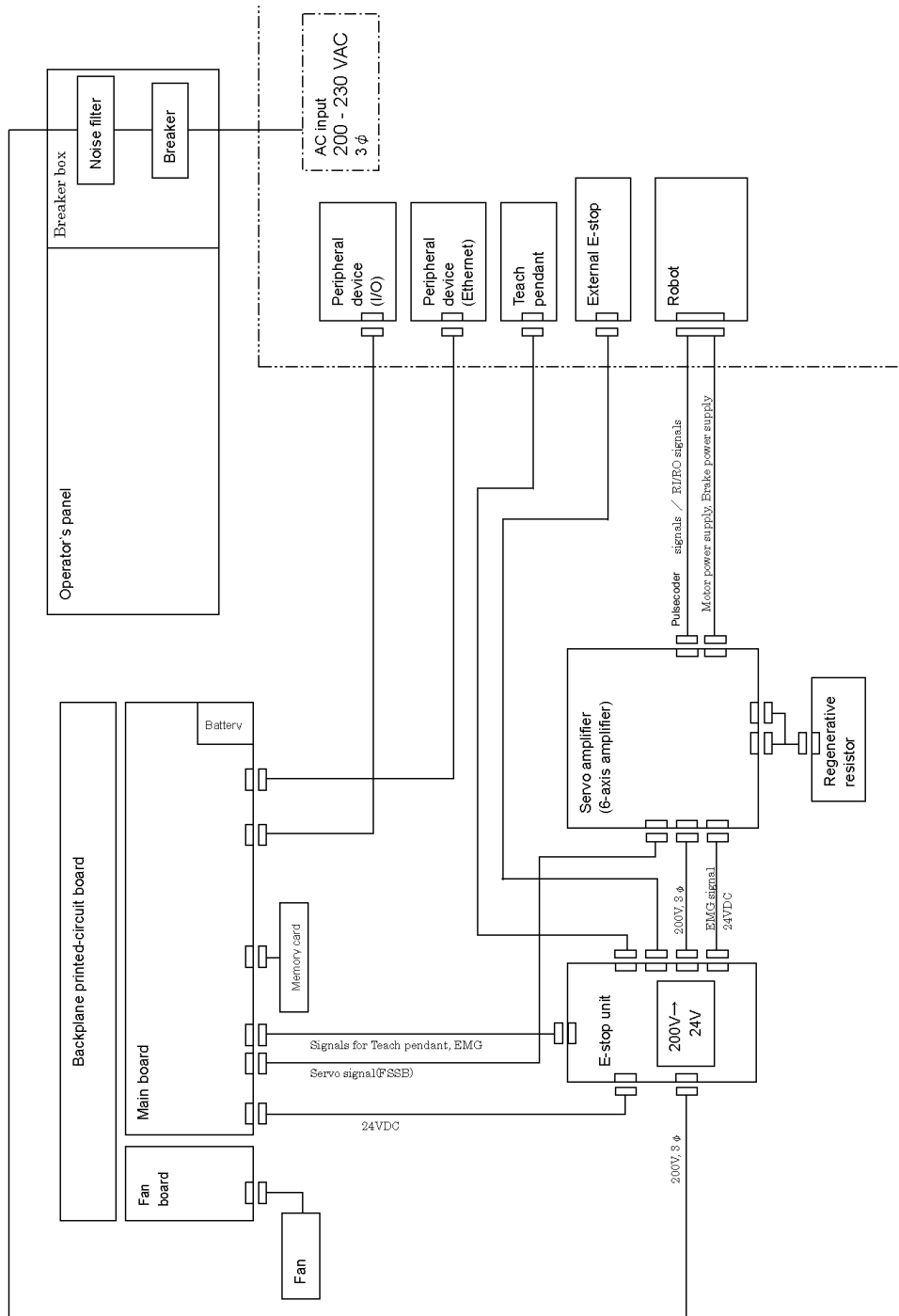


Fig.2.1 (i) Block diagram of the R-30iA Mate
 (ARC Mate 100iC, M-10iA, ARC Mate 120iC, M-20iA, ARC Mate 50iC, ARC Mate 0iA)

2.2 COMPONENT FUNCTIONS

- **Main board**
The main board contains a microprocessor, its peripheral circuits, memory, and operator's panel control circuit. The main CPU controls servo mechanism positioning.
- **I/O printed circuit board, FANUC I/O Unit MODEL-A**
Various types of printed circuit boards are provided for applications including process I/O. The FANUC I/O unit MODEL-A can also be installed. When it is used, various I/O types can be selected. These are connected with FANUC I/O Link.
- **E-stop unit and MCC unit**
This unit controls the emergency stop system for both of the magnetic contactor and the precharge of the servo amplifier.
- **Power supply unit**
The power supply unit converts the AC power to various levels of DC power.
- **Backplane printed circuit board**
The various control printed circuit boards are mounted on the backplane printed circuit board.
- **Teach pendant**
All operations including robot programming are performed with this unit. The controller status and data are indicated on the liquid-crystal display (LCD) on the pendant.
- **Servo amplifier**
The servo amplifier controls servomotor, Pulsecoder signal, brake control, overtravel and hand broken.
- **Operator's panel**
Buttons and LEDs on the operator's panel are used to start the robot and to indicate the robot status. The panel has a port and an USB interface for the serial interface to an external device and an interface to connect the memory card for data backup. It also controls the emergency stop control circuit.
- **Transformer**
The supply voltage is converted to an AC voltage required for the controller by the transformer.
- **Fan unit, heat exchanger**
These components cool the inside of the controller.
- **Circuit breaker**
If the electric system in the controller malfunctions, or if abnormal input power causes high current in the system, the input power is connected to the circuit breaker to protect the equipment.
- **Regenerative resistor**
To discharge the counter electromotive force from the servomotor, connect a regenerative resistor to the servo amplifier.

2.3 PREVENTIVE MAINTENANCE

Daily maintenance and periodic maintenance/inspection ensure reliable robot performance for extended periods of time.

(1) **Daily maintenance**

Before operating the system each day, clean each part of the system and check the system parts for any damage or cracks. Also, check the following:

(a) **Before operation**

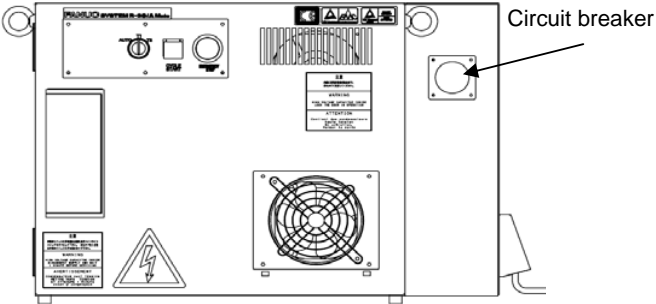
Check the cable connected to the teach pendant for excessive twisting. Check the controller and peripheral devices for abnormalities.

- (b) After operation
At the end of operation, return the robot to the specified position, and then turn off the controller. Clean each part, and check for any damage or cracks. If the ventilation port of the controller is dusty, clean it.
- (2) Check after one month
Check that the fan is rotating normally. If the fan has dirt and dust built up, clean the fan according to step (3) described below for inspection to be performed every 6 months.
- (3) Periodic inspection performed every six months.
 - (a) Remove any dirt and dust from the inside of the cabinet.
Wipe off dirt and dust from the fan.
 - (b) Check that the surge absorbers are not damaged.
Please refer to the section 3.8.
- (4) Battery daily check
Replace the battery on the front panel of the main board every 4 years. Please refer to the section 7.11.
- (5) Maintenance tools
The following maintenance tools are recommended:
 - (a) Measuring instruments
AC/DC voltmeter (A digital voltmeter is sometimes required.)
Oscilloscope with a frequency range of 5 MHz or higher, two channels
 - (b) Tools
Phillips screwdrivers: Large, medium, and small
Standard screwdrivers: Large, medium, and small
Nut driver set (Metric)
Pliers
Needle-nose pliers
Diagonal cutting pliers

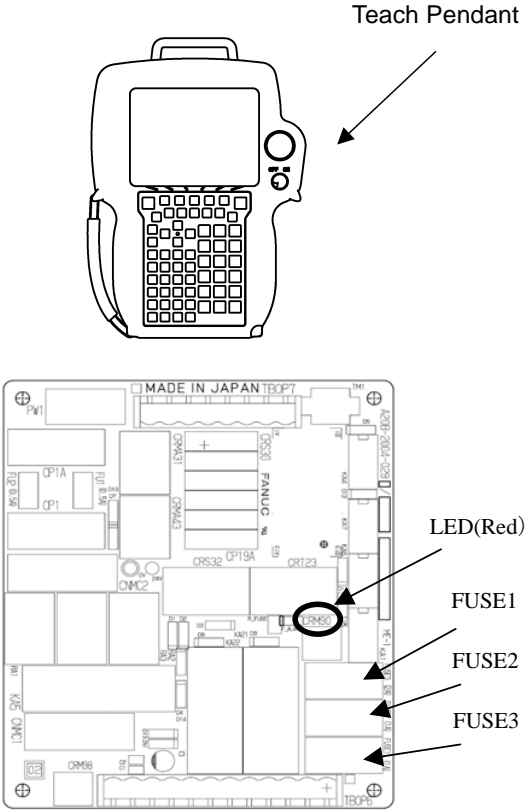
3 TROUBLESHOOTING

This chapter describes the checking method and corrective action for each error code indicated if a hardware alarm occurs. Refer to the operator's manual to release program alarms.

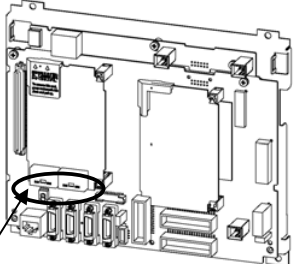
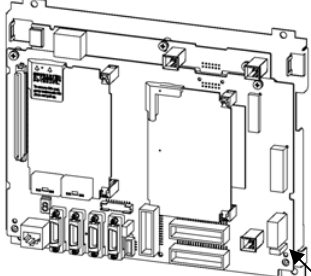
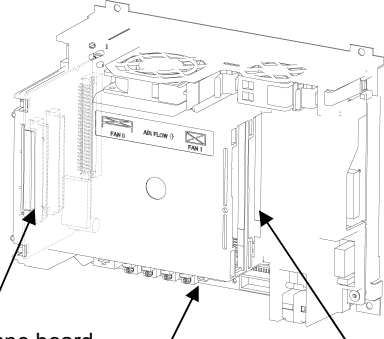
3.1 POWER CANNOT BE TURNED ON

Inspection and action		Illustration
(Inspection)	Check that the circuit breaker is on and has not tripped.	
(Action)	Turn on the circuit breaker.	

3.1.1 When the Teach Pendant Cannot be Powered on

Inspection and action		Illustration
(Inspection 1)	Confirm that fuse FUSE2 on the emergency stop printed circuit board is not blown. When it is blown, the LED on the emergency stop printed circuit board lights in red. When FUSE2 is blown, carry out action 1 and replace the fuse.	
(Inspection 2)	When FUSE2 is not blown, carry out action 2.	
(Action 1)	(a) Check the cable of the teach pendant for failure and replace it as necessary. (b) Check the teach pendant for failure and replace it as necessary. (c) Replace the emergency stop printed circuit board.	
(Action 2)	When the LED on the main board does not light, replace the emergency stop unit. When the LED on the main board lights, carry out action 1.	

3.1.2 When the Teach Pendant Does Not Change from the Initial Screen

Inspection and action		Illustration
(Inspection 1)	Check that the status display LCD and 7-segment LED on the main board operate normally.	 <p>7-segment LED and status display LED (On the main board)</p>
(Action)	Carry out an action according to the LED status. For details, see "TROUBLESHOOTING USING THE LEDS ON THE MAIN BOARD".	
(Inspection 2)	When the LED on the main board does not light in inspection 1, check if FUSE1 on the main board is blown. (a) When FUSE1 is blown See action 1. (b) When FUSE1 is not blown See action 2.	 <p>FUSE1</p>  <p>Back plane board Main board Option slot</p>
(Action 1)	(a) Replace the backplane board. (b) Replace the main board. (c) When an option board is installed in the option slot, replace the option board.	
(Action 2)	(a) Replace the emergency stop unit. (b) Replace the cable between the main board and the emergency stop unit. (c) Replace the boards indicated in action 1.	

3.2 ALARM OCCURRENCE SCREEN

The alarm occurrence screen displays only the alarm conditions that are currently active. If an alarm reset signal is input to reset the alarm conditions, the alarm occurrence screen displays the message "PAUSE or more serious alarm has not occurred."

The alarm occurrence screen displays only the alarm conditions (if any) that occur after the most recently entered alarm reset signal. To erase all alarm displays from the alarm occurrence screen. Press the CLEAR key (+ shift) on the alarm history screen.

The alarm occurrence screen is intended to display PAUSE or alarms that are more serious. It will not display WARN, NONE, or a reset. It is possible to disable PAUSE and some of more serious alarms from being displayed by setting the \$ER_NOHIS system variable appropriately.

If two or more alarms have occurred, the display begins with the most recent alarm.

Up to 100 lines can be displayed.

If an alarm has a cause code, it is displayed below the line indicating the alarm.

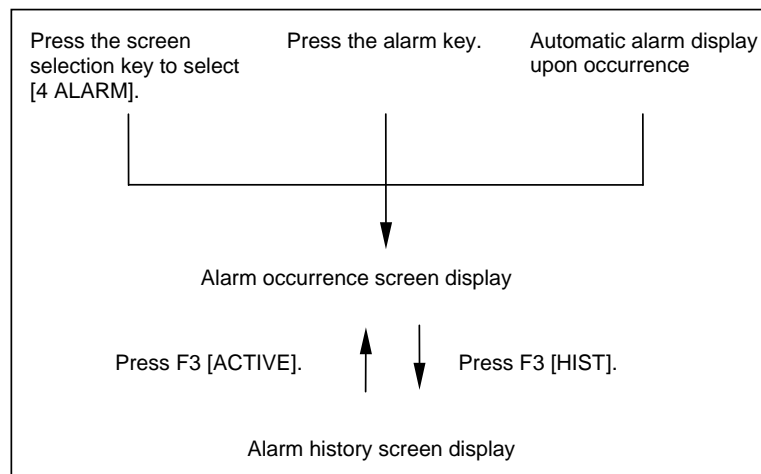
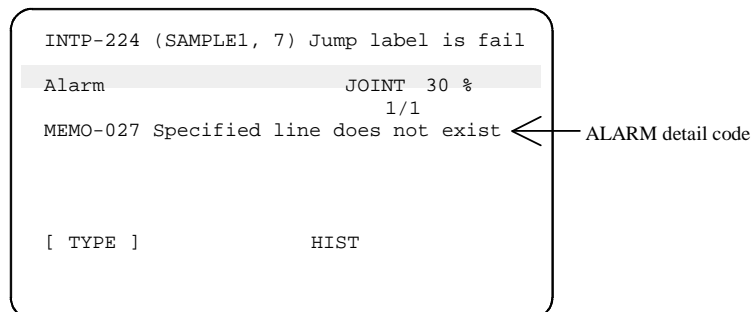
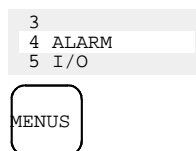


Fig.3.2 Alarm occurrence screen and alarm history screen display procedure

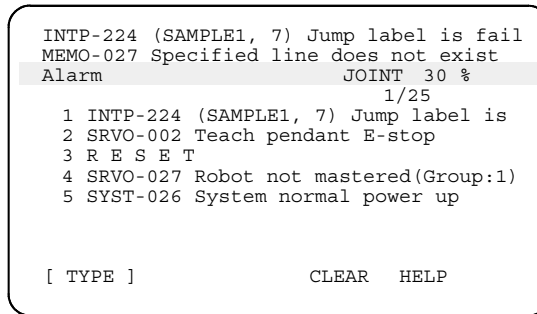
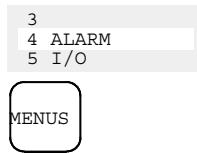
Displaying the alarm history/alarm detail information

Step

- (1) Press the MENUS key to display the screen menu.
- (2) Select [ALARM]. You will see a screen similar to the following
If an alarm has occurred, however, the alarm screen appears automatically.

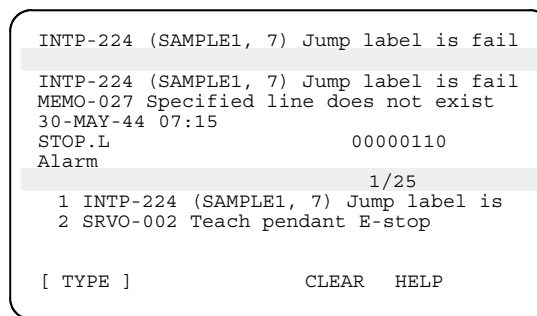
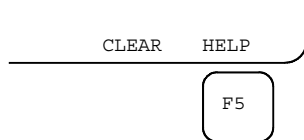


- (3) To display the alarm history screen, press F3, [HIST].
Press F3 [ACTIVE] again, the alarm screen appears.



NOTE
The latest alarm is assigned number 1. To view messages that are currently not on the screen, press the F5, HELP, and then press the right arrow key.

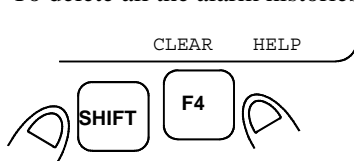
- (4) To display the alarm detail screen, press F5, [HELP].



- (5) To return to the alarm history screen, press the PREV key.

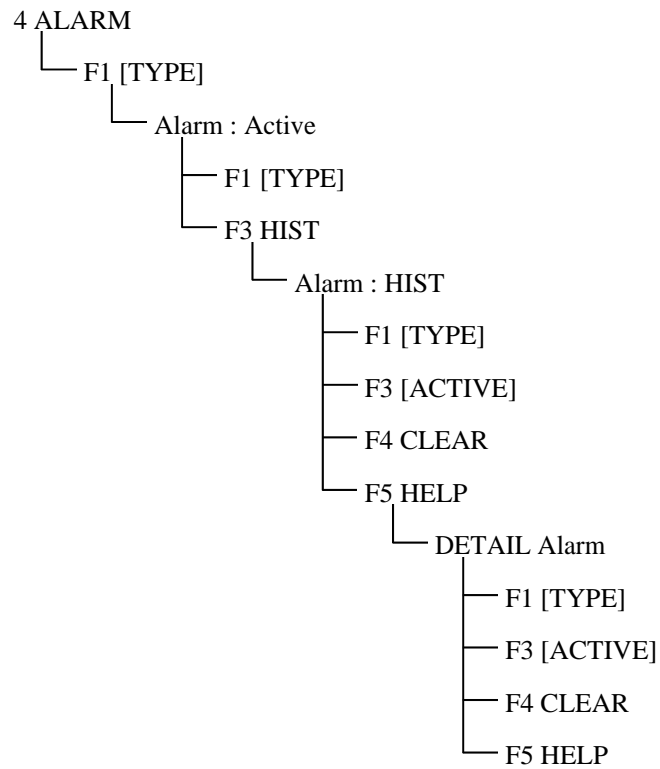


- (6) To delete all the alarm histories, press and hold down the SHIFT key, then press F4, [CLEAR].



NOTE
When system variable \$ER_NOHIS = 1, NONE alarms or WARN alarms are not recorded. When \$ER_NOHIS=2, resets are not recorded in the alarm history. When \$ER_NOHIS=3, resets, WARN alarms, and NONE alarms are not recorded.

The following map indicates teach pendant operations used to check an alarm.



3.3 SAFETY SIGNALS

The safety signal screen indicates the state of signals related to safety.

To be specific, the screen indicates whether each safety signal is currently on. On this screen, it is impossible to change the state of any safety signal.

Table 3.3 Safety signals

Safety signal	Description
Operator's panel emergency stop	This item indicates the state of the emergency stop button on the operator's panel. If the EMERGENCY STOP button is pressed, the state is indicated as "TRUE".
Teach pendant emergency stop	This item indicates the state of the emergency stop button on the teach pendant. If the EMERGENCY STOP button is pressed, the state is indicated as "TRUE".
External emergency stop	This item indicates the state of the external emergency stop signal. If the EMERGENCY STOP signal is asserted, the state is indicated as "TRUE".
Fence open	This item indicates the state of the safety fence. If the safety fence is open, the state is indicated as "TRUE".
DEADMAN switch	This item indicates whether the DEADMAN switch on the teach pendant is grasped. If the teach pendant is operable, and the DEADMAN switch is grasped correctly, the state is indicated as "TRUE". If the DEADMAN switch is released or is grasped tightly when the teach pendant is operable, an alarm occurs, causing the servo power to be switched off.
Teach pendant operable	This item indicates whether the teach pendant is operable. If the teach pendant is operable, the state is indicated as "TRUE".
Hand broken	This item indicates the state of the hand safety joint. If the hand interferes with a workpiece or anything like this, and the safety joint is opened, the state is indicated as "TRUE". In this case, an alarm occurs, causing the servo power to be switched off.
Robot overtravel	This item indicates whether the current position of the robot is out of the operation range. If any robot articulation goes out of the operation range beyond the overtravel switch, the state is indicated as "TRUE". In this case, an alarm occurs, causing the servo power to be switched off.
Abnormal air pressure	This item indicates the state of the air pressure. The abnormal air pressure signal is connected to the air pressure sensor. If the air pressure is not higher than the specified value, the state is indicated as "TRUE".

Step

- (1) Press the MENUS key to display the screen menu.
- (2) Select STATUS on the next page.
- (3) Press F1, [TYPE] to display the screen switching menu.
- (4) Select Safety Signal. You will see a screen similar to the following.

SYSTEM Safety		JOINT 30%
SIGNAL NAME	STATUS	1/11
1 SOP E-Stop:	FALSE	
2 TP E-stop:	FALSE	
3 Ext E-Stop:	FALSE	
4 Fence Open:	FALSE	
5 TP Deadman:	TRUE	
6 TP Enable:	TRUE	
7 Hand Broken:	FALSE	
8 Over Travel:	FALSE	
9 Low Air Alarm:		FALSE
[TYPE]		

3.4 MASTERING

Mastering is needed if:

- (1) The SRVO-062 BZAL or SRVO-038 pulse mismatch alarm occurs, or
- (2) The Pulsecoder is replaced.

Item (1) requires quick mastering, while item (2) requires zero-degree or fixture position mastering. (Zero-degree position mastering is just for quick-fix purposes. After zero-degree position mastering is used, fixture position mastering should be performed later.)

The mastering procedure is described below. For the procedure of mastering other than fixture position mastering, refer to the operator's manual of the mechanical unit.

For the procedure of fixture mastering, contact FANUC.

Condition

System variable \$MASTER_ENB must be set to 1 or 2.

SYSTEM Variables	JOINT 10%
57 \$MASTER_ENB	57/136 1

Step

- (1) Press <MENUS>.
- (2) Select SYSTEM.
- (3) Press F1, TYPE.
- (4) Select Master/Cal you will see a screen similar to the following.

The diagram illustrates the navigation steps through the CNC control interface:

- Initial screen: 9, 0 -- NEXT --
- Press **MENUS** to reach the menu screen: 5 POSITION, 6 SYSTEM, 7
- Press **F1** to reach the Mastering screen: Master TYPE
- The Mastering screen (SYSTEM Master/Cal) shows:
 - JOINT 30%
 - 1 FIXTURE POSITION MASTER
 - 2 ZERO POSITION MASTER
 - 3 QUICK MASTER
 - 4 SINGLE AXIS MASTER
 - 5 SET QUICK MASTER REF
 - 6 CALIBRATE
- Instruction: Press 'ENTER' or number key to select.
- Bottom status: [TYPE] LOAD RES_PCA DONE

- (5) Move the robot by jog feed to the mastering position. Release the brake on the manual brake control screen if necessary.

NOTE

Mastering cannot be performed until axis is rotated enough to establish a pulse.

- (6) Select "1 FIXTURE POSITION MASTER" and press the F4 key (yes). Mastering data is set.

```

SYSTEM Master/Cal
1 FIXTURE POSITION MASTER
2 ZERO POSITION MASTER
Master at master position?
-----
Master at master position?
[ TYPE ] YES NO
    
```

ENTER

F4

```

SYSTEM Master/Cal JOINT 30 %
1 FIXTURE POSITION MASTER
2 ZERO POSITION MASTER
3 QUICK MASTER
4 SINGLE AXIS MASTER
5 SET QUICK MASTER REF
6 CALIBRATE
Robot Mastered! Mastering Data:
<0> <11808249> <38767856>
<9873638> <122000309> <2000319>
[ TYPE ] LOAD RES_PCA DONE
    
```

- (7) Select "6 CALIBRATE" and press the F4 key (yes). Calibration is performed. Alternatively, to perform positioning, turn the power off, and then turn it on again. Calibration is performed whenever the power is turned on.

```

5 SET QUICK MASTER REF
6 CALIBRATE
Calibrate? [NO]
-----
Calibrate? [NO]
[ TYPE ] YES
    
```

ENTER

F4

```

SYSTEM Master/Cal JOINT 30 %
1 FIXTURE POSITION MASTER
2 ZERO POSITION MASTER
3 QUICK MASTER
4 SINGLE AXIS MASTER
5 SET QUICK MASTER REF
6 CALIBRATE
Robot Calibrated! Cur Jnt Ang(deg) :
<10.000> <-25.000> <40.000>
<5.000> <-15.000> <0.000>
[ TYPE ] LOAD RES_PCA DONE
    
```

- (8) Press F5 "DONE", after mastering.

```

DONE
-----
F5
    
```


3.5 TROUBLESHOOTING USING THE ERROR CODE

(1) SRVO-001 Operator panel E-stop

- (Explanation) The emergency stop button on the operator's panel is pressed.
- (Action 1) Release the emergency stop button pressed on the operator's panel.
- (Action 2) Check the wires connecting between the emergency stop button and the E-stop board (CRT23) for continuity. If an open wire is found, replace the entire harness.
- (Action 3) With the emergency stop in the released position, check for continuity across the terminals of the switch. If continuity is not found, the emergency stop button is broken. Replace the switch unit or the operator's panel.
- (Action 4) Replace the E-stop board.

Before executing the (Action 5), perform a complete controller back-up to save all your programs and settings.

- (Action 5) Replace the main board.

NOTE

If the LED (red) on the E-stop unit is lit, a fuse may have blown. Take the same actions described in (3) in Section 3.6.

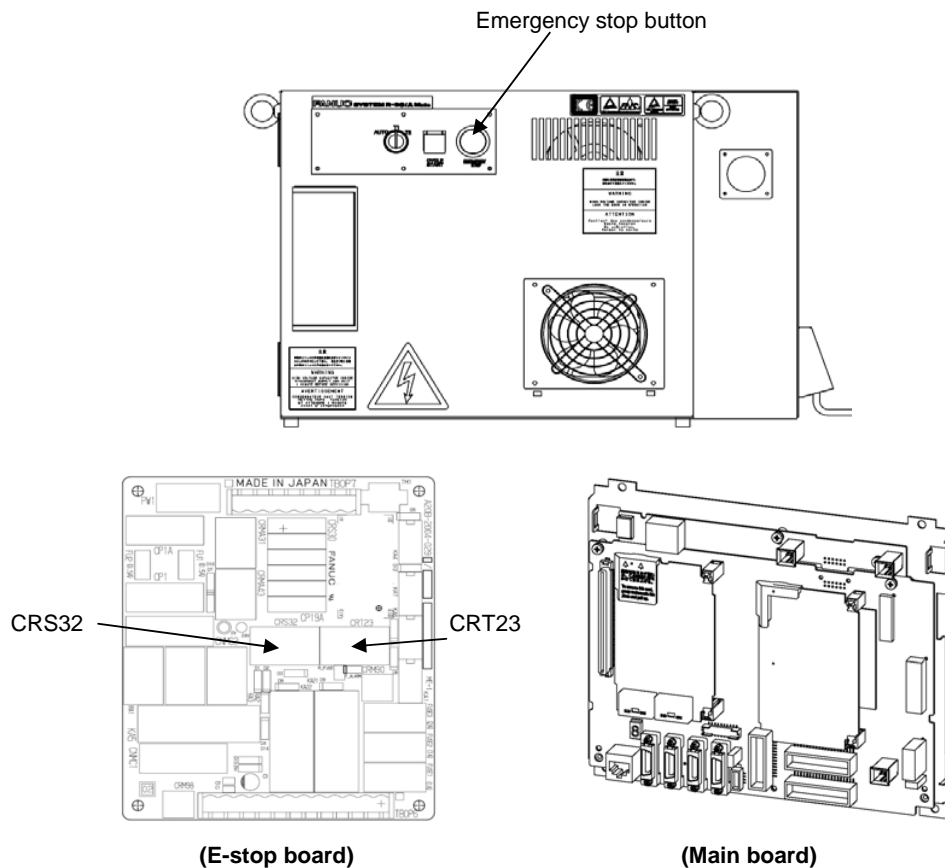


Fig.3.5 (a) SRVO-001 Operator panel E-stop

- (2) SRVO-002 Teach pendant E-stop
 (Explanation) The emergency stop button on the teach pendant was pressed.
 (Action 1) Release the emergency stop button on the teach pendant.
 (Action 2) Replace the teach pendant.

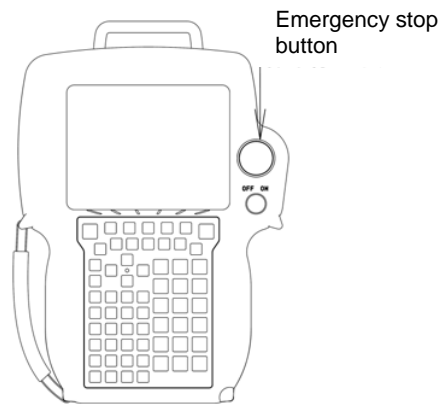


Fig.3.5 (b) SRVO-002 Teach pendant E-stop

- (3) SRVO-003 DEADMAN switch released
 (Explanation) The teach pendant is enabled, but the DEADMAN switch is not pressed. Alternatively, the DEADMAN switch is pressed strongly.
 (Action 1) Check the intermediate position of the DEADMAN switch on the teach pendant.
 (Action 2) Check that the mode switch on the operator's panel and the enable switch on the teach pendant are at the correct positions.
 (Action 3) Replace the teach pendant.
 (Action 4) Check the mode switch connection and operation. If trouble is found, replace the mode switch.
 (Action 5) Replace the E-stop board.
 (Action 6) Replace the main board.

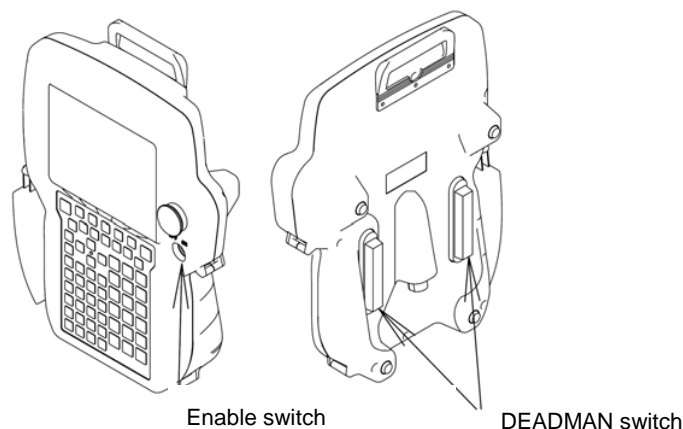


Fig.3.5 (c) SRVO-003 DEADMAN switch released

- (5) SRVO-005 Robot overtravel
- (Explanation) The robot has moved beyond a hardware limit switch on the axes.
- (Action 1)
- 1) Select [System OT release] on the overtravel release screen to release each robot axis from the overtravel state.
 - 2) Hold down the shift key, and press the alarm release button to reset the alarm condition.
 - 3) Still hold down the shift key, and jog to bring all axes into the movable range.
- (Action 2) Replace the limit switch.
- (Action 3) Check the FS2 fuse on the servo amplifier. If the SRVO-214 fuse blown alarm is also generated, the FS2 fuse has blown.
- (Action 4) Check the end effector connector.
- (Action 5) Replace the servo amplifier.
- (Action 6) Verify the following for connector RMP at the base of the robot:
- 1) There are no bent or dislocated pins in the male or female connectors.
 - 2) The connector is securely connected.
- Then verify that connectors CRF8 and CRM68 on the servo amplifier are securely connected. Also, verify that the RMP cable is in good condition, and there are no cuts or kinks visible. If no limit switch is in use, jumper connector must be attached in the mechanical unit. Check for the jumper connector.

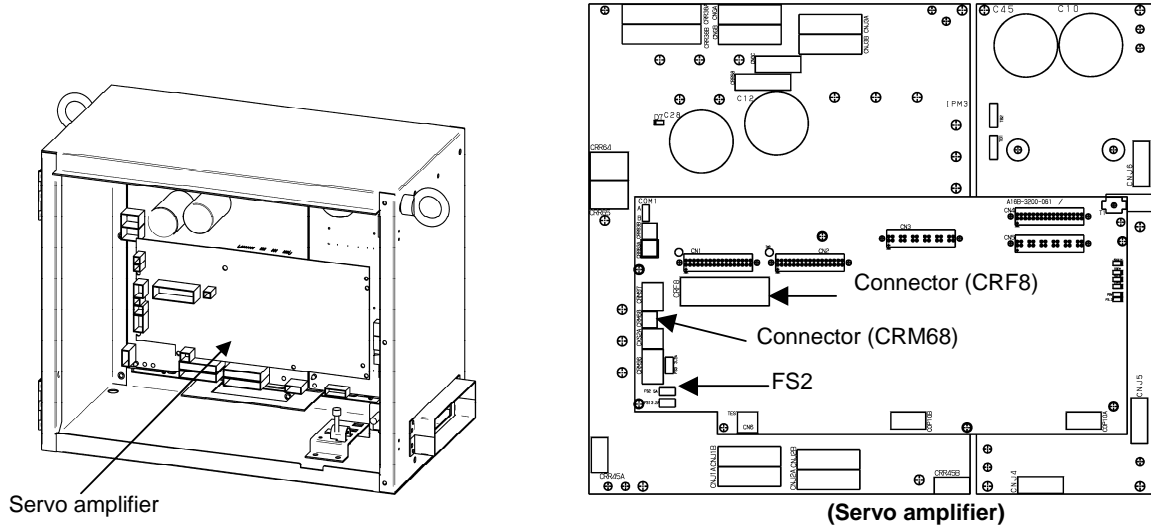
NOTE

It is factory-placed in the overtravel state for packing purposes.
If the Overtravel signal is not in use, it may have been disabled by short-circuiting in the mechanical unit.

- (6) SRVO-006 Hand broken
- (Explanation) The safety joint (if in use) might have been broken. Alternatively, the HBK signal on the robot connection cable might be a ground fault or a cable disconnection.
- (Action 1) Hold down the shift key, and press the alarm release button to reset the alarm condition. Still hold down the shift key, and jog the tool to the work area.
- 1) Replace the safety joint.
 - 2) Check the safety joint cable.
- (Action 2) Replace the servo amplifier.
- (Action 3) Verify the following for connector RMP at the base of the robot:
- 1) There are no bent or dislocated pins in the male or female connectors.
 - 2) The connector is securely connected.
- Then verify that connector CRF8 on the servo amplifier is securely connected. Also, verify that the RMP cable is in good condition, and there are no cuts or kinks visible. Check the robot connection cable (RMP) for a ground fault or a cable disconnection.

NOTE

If the Hand broken signal is not in use, it can be disabled by software setting.
Refer to Subsection 5.6.4 How to Disable/Enable HBK in Part III,
"CONNECTIONS" of "Maintenance Manual" to disable the Hand broken signal.



**Fig.3.5 (e) SRVO-005 Robot overtravel
SRVO-006 Hand broken**

(7) SRVO-009 Pneumatic pressure abnormal

- (Explanation) An abnormal air pressure was detected. The input signal is located on the end effector of the robot. Refer to the manual of your robot.
- (Action 1) If an abnormal air pressure is detected, check the cause.
- (Action 2) Check the end effector connector.
- (Action 3) Check the robot connection cable (RMP) for a ground fault or a cable disconnection. If a fault or a disconnection is detected, replace the cable.
- (Action 4) Replace the servo amplifier.
- (Action 5) Replace the internal cables of the robot.

NOTE

Pneumatic pressure alarm input is on the end effector. Please refer to the manual of your robot.

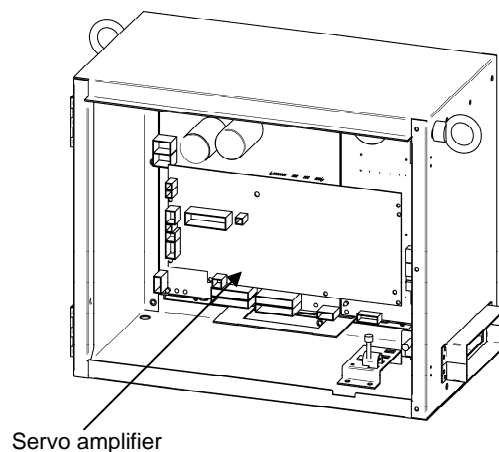


Fig.3.5 (f) SRVO-009 Pneumatic pressure alarm

(8) SRVO-014 Fan motor abnormal

(Explanation) A fan motor in the controller backplane unit is abnormal.

(Action 1) Replace a fan motor in the controller backplane unit.

(Action 2) Replace the fan board.

Before executing the (Action 3), perform a complete controller back-up to save all your programs and settings.

(Action 3) Replace the main board.

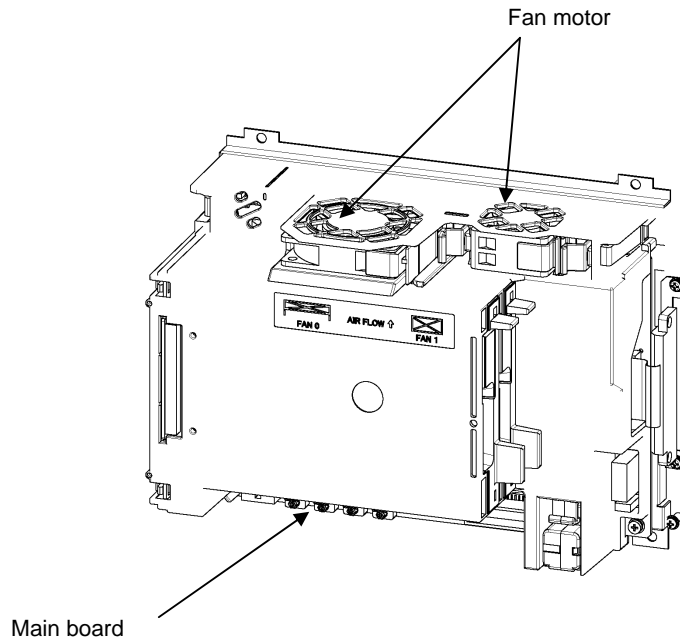


Fig.3.5 (g) SRVO-014 Fan motor abnormal

(9) SRVO-015 SYSTEM OVER HEAT (Group: i Axis: j)

(Explanation) The temperature in the control unit exceeds the specified value.

(Action 1) If the ambient temperature is higher than specified (45°C), cool down the ambient temperature.

(Action 2) If the fan motor is not running, check it and its cables. Replace them if necessary.

Before executing the (Action 3), perform a complete controller back-up to save all your programs and settings.

(Action 3) Replace the main board. (The thermostat on the main board may be faulty.)

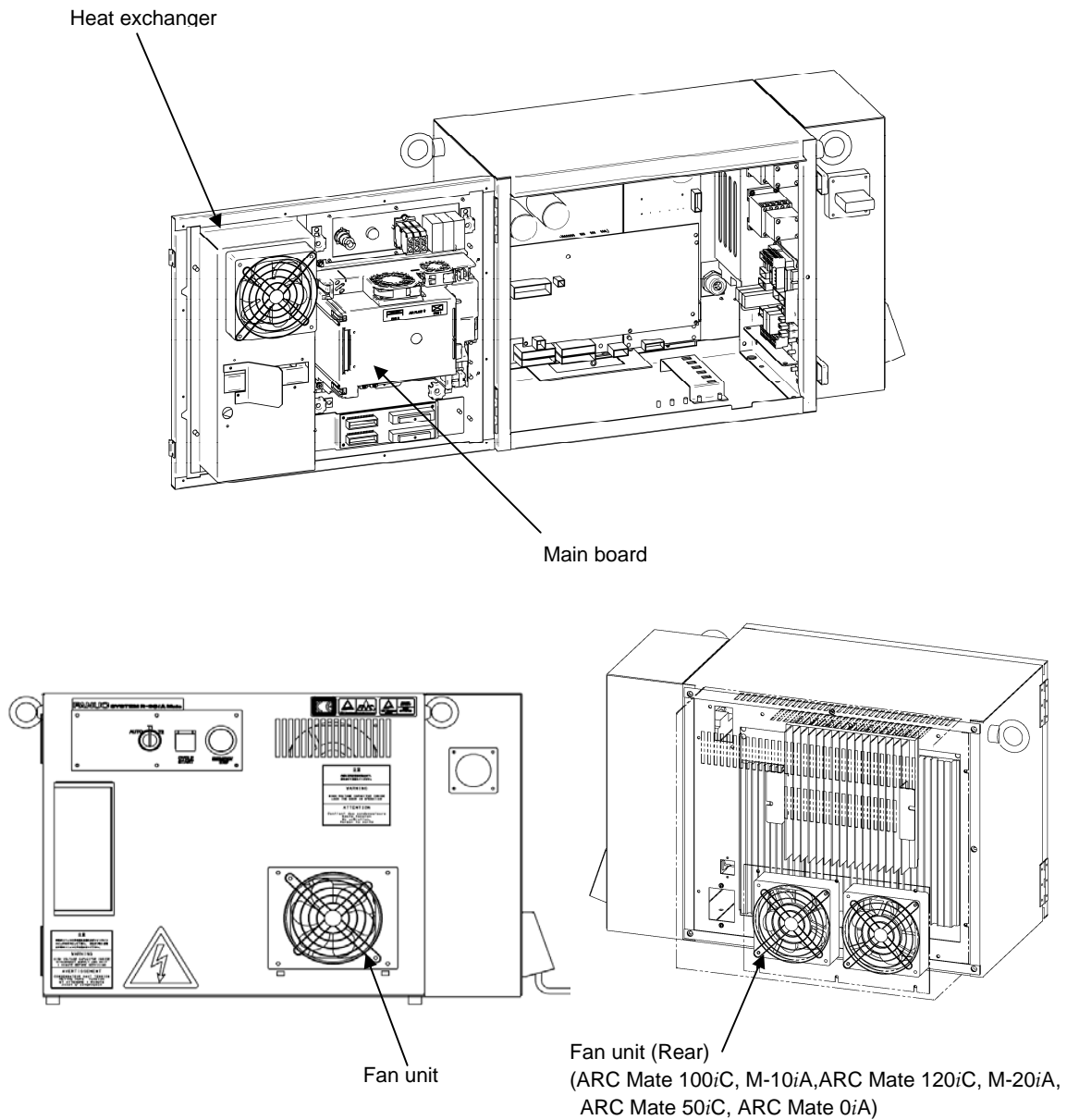


Fig.3.5 (h) SRVO-015 SYSTEM OVER HEAT

(10) SRVO-018 Brake abnormal

- (Explanation) An excessive brake current is detected. The ALM LED on the servo amplifier is lit.
- (Action 1) Check the cables and motor brakes connected to CRR88 connector on the servo amplifier.
If a short-circuit or grounding fault is found, replace the failed part.
- (Action 2) Check the cables and motor brakes connected to CRR65A, CRR65B connector on the servo amplifier. If a short-circuit or grounding fault is found, replace the failed part.
- (Action 3) Replace the servo amplifier.

**CAUTION**

This error can be caused by the optional brake release unit if the on/off switch is left in on position while the operator attempts to jog the robot. To recover, turn the brake release unit off and cycle the controller power.

(11) SRVO-021 SRDY off (Group: i Axis: j)

- (Explanation) The HRDY is on and the SRDY is off, although there is no other cause of an alarm. (HRDY is a signal with which the host detects the servo system whether to turn on or off the servo amplifier magnetic contactor. SRDY is a signal with which the servo system informs the host whether the magnetic contactor is turned on.)
If the servo amplifier magnetic contactor cannot be turned on when directed so, it is most likely that a servo amplifier alarm has occurred. If a servo amplifier alarm has been detected, the host will not issue this alarm (SRDY off). Therefore, this alarm indicates that the magnetic contactor cannot be turned on for an unknown reason.
- (Action 1) Make sure that the E-stop board connectors CRMA43, CRMA31 and servo amplifier SRMA43 are securely attached to the servo amplifier.
- (Action 2) It is possible that an instant disconnection of power source causes this alarm. Check whether an instant disconnection occurred.
- (Action 3) Replace the E-stop unit.
- (Action 4) Replace the servo amplifier.

(12) SRVO-022 SRDY on (Group: i Axis: j)

- (Explanation) When the HRDY is about to go on, the SRDY is already on. (HRDY is a signal with which the host directs the servo system whether to turn on or off the servo amplifier magnetic contactor. SRDY is a signal with which the servo system informs the host whether the magnetic contactor is turned on.)
- (Action 1) Replace the servo amplifier as the alarm message.

(13) SRVO-023 Stop error excess (Group: i Axis: j)

(Explanation) When the servo is at stop, the position error is abnormally large.
Check whether the brake is released through the clack sound of the brake or vibration.

In case that the brake is not released.

(Action 1) If the brake is not released, check the continuity of the brake line in the robot connection cable and the robot internal cable.

(Action 2) If the disconnection is not found, replace the servo amplifier or the servo motor.

In case that the brake is released.

(Action 1) Check whether the obstacle disturbs the robot motion.

(Action 2) Make sure that connectors CNJ1A-CNJ6 are securely attached to the servo amplifier.

(Action 3) Check the continuity of the robot connection cable and the internal robot power cable.

(Action 4) Check to see if the load is greater than the rating. If greater, reduce it to within the rating. (If the load is too great, the torque required for acceleration / deceleration becomes higher than the capacity of the motor.

As a result, the motor becomes unable to follow the command, and an alarm is issued.)

(Action 5) Check the input voltage to the controller is within the rated voltage and no phase is lack. In addition, check the setting of the transformer is correct.

Check each phase voltage of the CRR38A connector of the three-phase power (200 VAC) input to the servo amplifier. If it is 210 VAC or lower, check the line voltage. (If the voltage input to the servo amplifier becomes low, the torque output also becomes low. As a result, the motor may become unable to follow the command, hence possibly causing an alarm.)

(Action 6) Replace the servo amplifier.

(Action 7) Replace the motor of the alarm axis.

NOTE

Incorrect setting of the brake number causes this alarm.

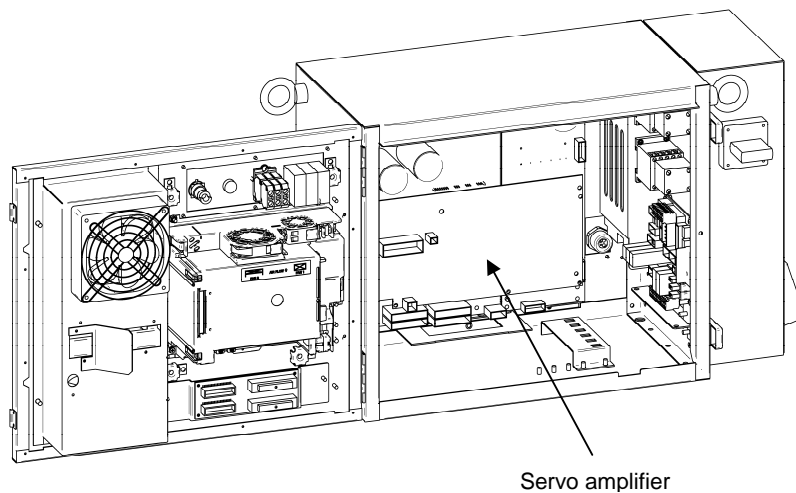


Fig.3.5 (i) SRVO-018 Brake abnormal
SRVO-021 SRDY off
SRVO-022 SRDY on
SRVO-023 Stop error excess

- (14) SRVO-024 Move error excess (Group: i Axis: j)
(Explanation) When the robot is running, its position error is greater than a specified value (\$PARAM _ GROUP. \$MOVER _ OFFST). It is likely that the robot cannot follow the speed specified by program.
(Action 1) Take the same actions as SRVO-023.
- (15) SRVO-027 Robot not mastered (Group: i)
(Explanation) An attempt was made to calibrate the robot, but the necessary adjustment had not been completed.
(Action) Check whether the mastering is valid. If the mastering is invalid, master the robot.

**WARNING**

If the position data is incorrect, the robot or additional axis can operate abnormally, set the position data correctly. Otherwise, you could injure personnel or damage equipment.

- (16) SRVO-030 Brake on hold (Group:i)
(Explanation) If the temporary halt alarm function is enabled (\$SCR.\$BRKHOLD ENB=1), SRVO-030 is issued when a temporary halt occurs. When this function is not used, disable the setting.
(Action) Disable [Servo-off in temporary halt] on the general item setting screen [6 General Setting Items].
- (17) SRVO-033 Robot not calibrated (Group: i)
(Explanation) An attempt was made to set up a reference point for quick mastering, but the robot had not been calibrated.
(Action) Calibrate the robot.
1. Supply power.
2. Set up a quick mastering reference point using [Positioning] on the positioning menu.
- (18) SRVO-034 Ref pos not set (Group: i)
(Explanation) An attempt was made to perform quick mastering, but the reference point had not been set up.
(Action) Set up a quick mastering reference point on the positioning menu.
- (19) SRVO-036 Inpos time over (Group: i Axis: j)
(Explanation) The robot did not get to the effective area (\$PARAM _ GROUP.\$ STOPTOL) even after the position check monitoring time (\$PARAM _ GROUP. \$INPOS _ TIME) elapsed.
(Action) Take the same actions as for SRVO-023 (large position error at a stop).
- (20) SRVO-037 IMSTP input (Group: i)
(Explanation) The *IMSTP signal for a peripheral device interface was input.
(Action) Turn on the *IMSTP signal.

(21) SRVO-038 Pulse mismatch (Group: i Axis: j)

(Explanation) The pulse count obtained when power is turned off does not match the pulse count obtained when power is applied. This alarm is asserted after exchange the Pulsecoder or battery for back up of the Pulsecoder data or loading back up data to the Main Board.

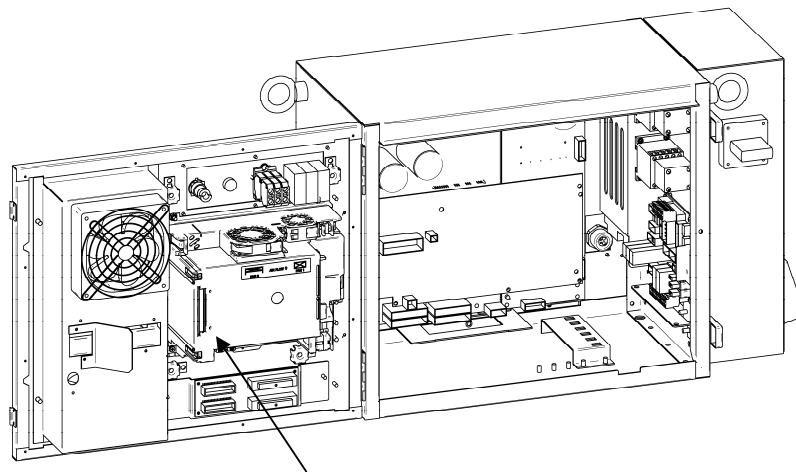
Check the alarm history.

(Action 1) If the brake number is set to the non-brake motors, this alarm may occur. Check the software setting of the brake number.

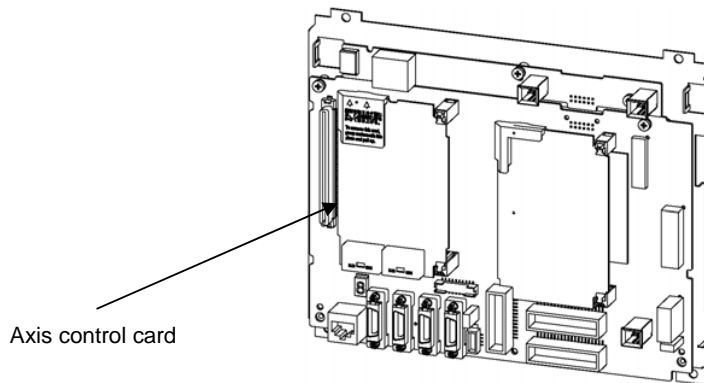
(Action 2) In case the robot has been moved by using the brake release unit while the power is off or when restoring the back-up data to the main board, this alarm may occur. Remaster the robot.

(Action 3) If the robot has been moved because the brake failed, this alarm may occur. Check the cause of the brake trouble. Then remaster the robot.

(Action 4) Replace the Pulsecoder and master the robot.



Main board



Axis control card

Fig.3.5 (j) SRVO-038 Pulse mismatch

- (22) SRVO-042 MCAL alarm (Group: i Axis: j)
- (Explanation) This alarm means that the contacts of the magnetic contactor have stuck to each other. The alarm condition occurs if the magnetic contactor turns out to be already on when an attempt is made to turn it on. The alarm condition is detected between the time contact sticking occurs and the time an attempt is made to turn on the magnetic contactor.
- (Action 1) Replace the E-stop unit.
- (Action 2) Replace the servo amplifier.
- (23) SRVO-043 DCAL alarm (Group: i Axis: j)
- (Explanation) The regenerative discharge energy was too high to be dissipated as heat. (To run the robot, the servo amplifier supplies energy to the robot. When going down the vertical axis, the robot operates from the potential energy. If a reduction in the potential energy is higher than the energy needed for acceleration, the servo amplifier receives energy from the motor. A similar phenomenon occurs even when no gravity is applied, for example, at deceleration on a horizontal axis. The energy that the servo amplifier receives from the motor is called the regenerative energy. The servo amplifier dissipates this energy as heat. If the regenerative energy is higher than the energy dissipated as heat, the difference is stored in the servo amplifier, causing an alarm.)
- (Action 1) This alarm may occur if the axis is subjected to frequent acceleration/deceleration or if the axis is vertical and generates a large amount of regenerative energy. If this alarm has occurred, relax the service conditions.
- (Action 2) Check fuse FS3 in the servo amplifier. If it has blown, remove the cause, and replace the fuse. One of the probable causes of a blown fuse is a ground fault in the servo amplifier for the auxiliary axis.
- (Action 3) The ambient temperature is excessively high. Or the regenerative resistor can't be cooled effectively. Check the fan unit, and replace it if it stops. Clean up the fan unit, the regenerative resistor and the louver if they are dirty.
- (Action 4) Make sure that the phase-to-phase voltages of input power fall within the specified range by measurement. If the voltages are out of the range, inspect the power equipment. When no failure is found, replace the E-stop unit.
- (Action 5) Make sure that the servo amplifier CRR63A and CRR63B connectors are connected tightly. Then detach the cable from CRR63A and CRR63B connectors on the Servo amplifier, and check for continuity between pins 1 and 2 of the cable-end connector. If there is no continuity between the pins, replace the regenerative resistor.
- (Action 6) Make sure that the servo amplifier CRR45A and CRR45B are connected tightly, then detach the cables from CRR45A and CRR45B on the servo amplifier and check the resistance between pins 1 and 2 of each cable end connector. If the resistance is not 9Ω , replace the regenerative resistor. CRR45B may not be used depending on the robot model.
- (Action 7) Replace the servo amplifier.

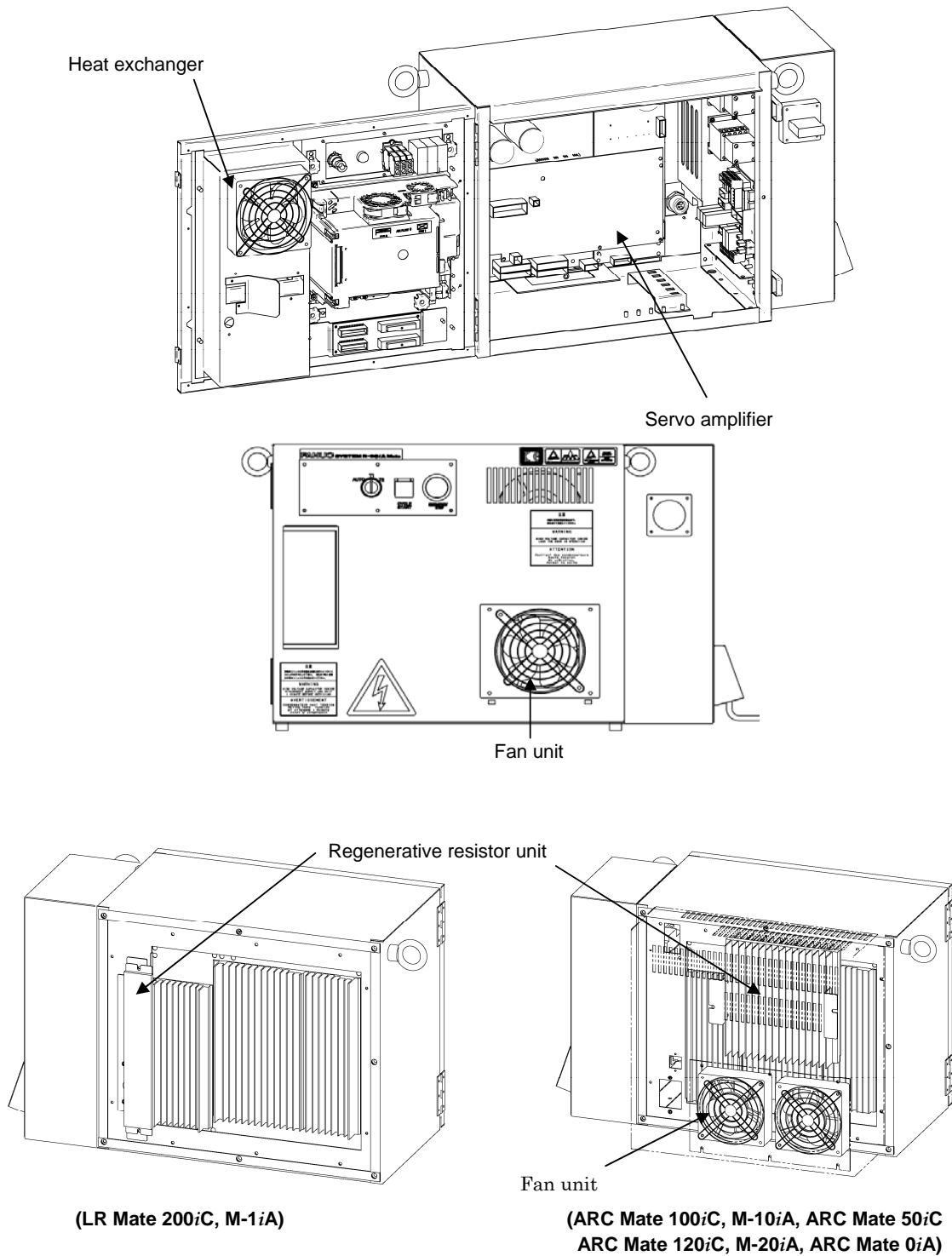


Fig.3.5 (k) SRVO-042 MCAL alarm
SRVO-043 DCAL alarm

- (24) SRVO-044 HVAL alarm (Group: i Axis: j)
- (Explanation) The DC voltage (DC link voltage) of the main circuit power supply is abnormally high.
- (Action 1) Check the three-phase input voltage at the servo amplifier. If it is 230 VAC or higher, check the line voltage. (If the three-phase input voltage is higher than 230 VAC, high acceleration/deceleration can cause in this alarm.)
- (Action 2) Check that the load weight is within the rating. If it is higher than the rating, reduce it to within the rating. (If the machine load is higher than the rating, the accumulation of regenerative energy might result in the HVAL alarm even when the three-phase input voltage is within the rating.)
- (Action 3) Check that the CRR63A and CRR63B connectors of the servo amplifier are attached firmly. Next, detach the cables then check the continuity between pins 1 and 2 of the cable-side connectors. If a disconnection is found, replace the regenerative resistor.
- (Action 4) Replace the servo amplifier.

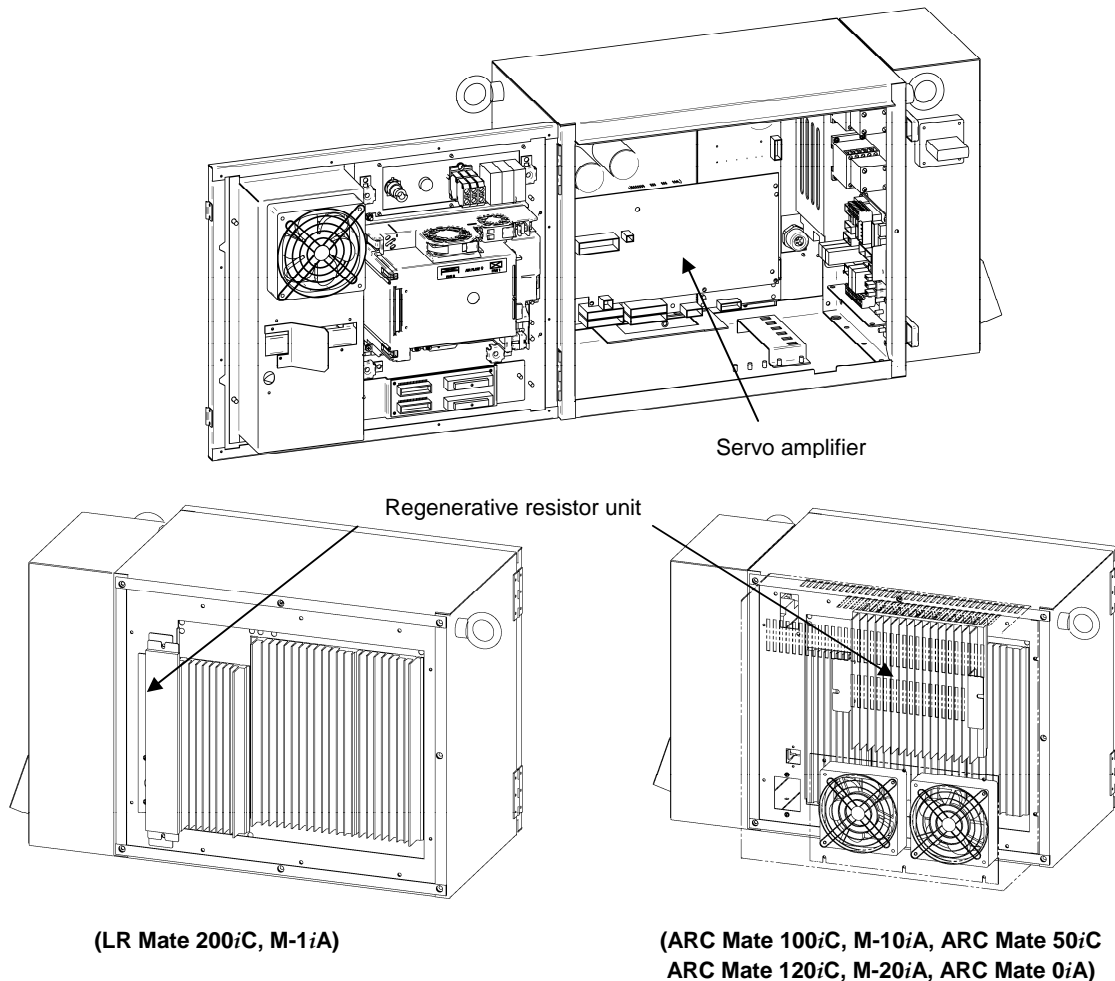
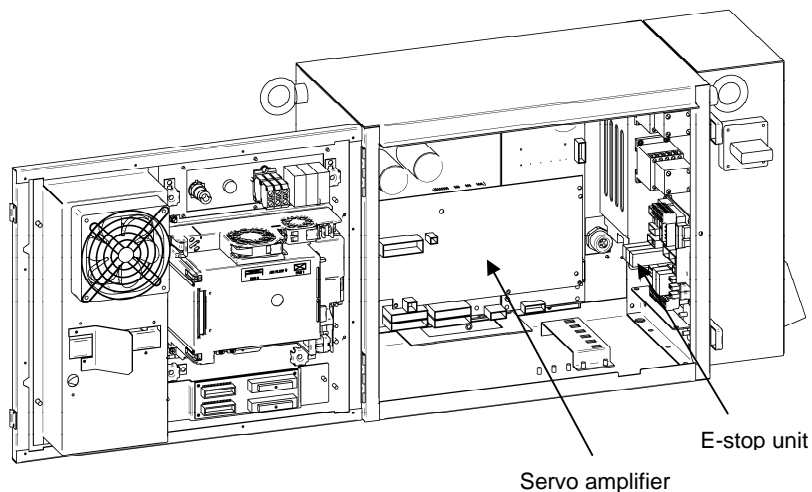


Fig.3.5 (I) SRVO-044 HVAL alarm

- (25) SRVO-045 HCAL alarm (Group: i Axis: j)
- (Explanation) Abnormally high current flowed in the main circuit of the servo amplifier.
- (Action 1) Turn off the power, and disconnect the power cable from the servo amplifier indicated by the alarm message. (And disconnect the brake cable (CRR88 on the servo amplifier) to avoid the axis falling unexpectedly.) Supply power and see if the alarm occurs again. If the alarm occurs again, replace the servo amplifier.
- (Action 2) Turn off the power and disconnect the power cable from the servo amplifier indicated by the alarm message, and check the insulation of their U, V, W and the GND lines each other. If there is a short-circuit, replace the power cable.
- (Action 3) Turn off the power and disconnect the power cable from the servo amplifier by the alarm message, and measure the resistance between their U and V, V and W and W and U with an ohmmeter that has a very low resistance range. If the resistances at the three places are different from each other, the motor, the power cable is defective. Check each item in detail and replace it if necessary.
- (26) SRVO-046 OVC alarm (Group: i Axis: j)
- (Explanation) This alarm is issued to prevent the motor from thermal damage that might occur when the root mean square current calculated within the servo system is out of the allowable range.
- (Action 1) Check the operating condition for the robot and relax the service condition if possible. If the load or operating condition has exceeded the rating, reduce the load or relax the operating condition to meet the rating.
- (Action 2) Check whether the voltage input to the controller is within the rated voltage and check whether the voltage set for the transformer of the controller is correct.
- (Action 3) Check whether the brake of the corresponding axis is released.
- (Action 4) Check whether there is a factor that has increased the mechanical load on the corresponding axis.
- (Action 5) Replace the servo amplifier.
- (Action 6) Replace the motor of the corresponding axis.
- (Action 7) Replace the E-stop unit
- (Action 8) Replace the motor power line (robot connection cable) of the corresponding axis.
- (Action 9) Replace the motor power line and brake line (inside the mechanical section) of the corresponding axis.



**Fig.3.5 (m) SRVO-045 HCAL alarm
SRVO-046 OVC alarm**

Reference

Relationships among the OVC, OHAL, and HC alarms

- Overview

This section points out the differences among the OVC, OHAL, and HC alarms and describes the purpose of each alarm.

- Alarm detection section

Abbreviation	Designation	Detection section
OVC	Overcurrent alarm	Servo software
OHAL	Overheat alarm	Thermal relay in the motor Thermal relay in the servo amplifier Thermal relay in the separate regenerative discharge unit
HC	High current alarm	Servo amplifier

- Purpose of each alarm

1) HC alarm (high current alarm)

If high current flow in a power transistor momentarily due to abnormality or noise in the control circuit, the power transistor and rectifier diodes might be damaged, or the magnet of the motor might be degaussed. The HC alarm is intended to prevent such failures.

2) OVC and OHAL alarms (overcurrent and overload alarms)

The OVC and OHAL alarms are intended to prevent overheat that may lead to the burnout of the motor winding, the breakdown of the servo amplifier transistor, and the separate regenerative resistor.

The OHAL alarm occurs when each built-in thermal relay detects a temperature higher than the rated value. However, this method is not necessarily perfect to prevent these failures. For example, if the motor frequently repeats to start and stop, the thermal time constant of the motor, which has a large mass, becomes higher than the time constant of the thermal relay, because these two components are different in material, structure, and dimension. Therefore, if the motor continues to start and stop within a short time as shown in Fig. 3.5 (n), the temperature rise in the motor is steeper than that in the thermal relay, thus causing the motor to burn before the thermal relay detects an abnormally high temperature.

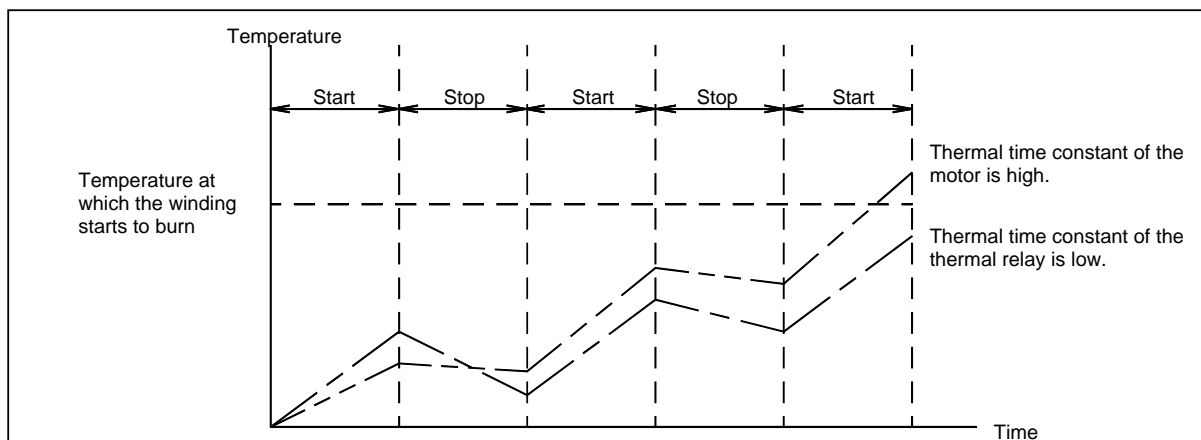


Fig.3.5 (n) Relationship between the temperatures of the motor and thermal relay on start/stop cycles

To prevent the above defects, software is used to monitor the current in the motor constantly in order to estimate the temperature of the motor. The OVC alarm is issued based on this estimated temperature. This method estimates the motor temperature with substantial accuracy, so it can prevent the failures described above.

To sum up, a double protection method is used; the OVC alarm is used for protection from a short-time overcurrent, and the OHAL alarm is used for protection from long-term overload. The relationship between the OVC and OHAL alarms is shown in Fig.3.5 (o).

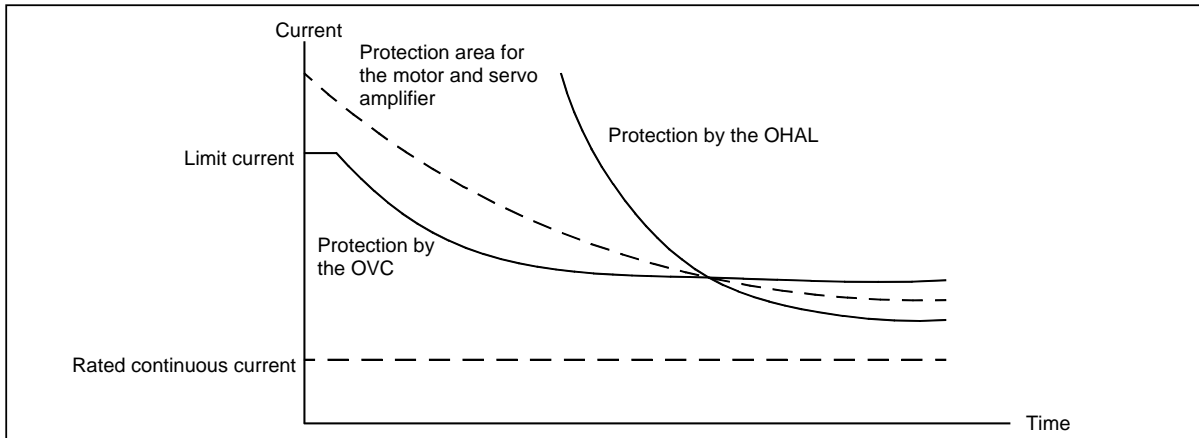


Fig.3.5 (o) Relationship between the OVC and OHAL alarms

NOTE

The relationship shown in Fig.3.5 (o) is taken into consideration for the OVC alarm. The motor might not be hot even if the OVC alarm has occurred. In this case, do not change the parameters to relax protection.

- (27) SRVO-047 LVAL alarm (Group: i Axis: j)
 (Explanation) The control power supply voltage (+5 V, etc.) supplied from the power supply circuit in the servo amplifier is abnormally low.
 (Action 1) Replace the servo amplifier.
 (Action 2) Replace the power supply unit.
- (28) SRVO-050 CLALM alarm (Group: i Axis: j)
 (Explanation) The disturbance torque estimated by the servo software is abnormally high. (A collision has been detected.)
 (Action 1) Check whether the robot has collided and check whether there is a factor that has increased the mechanical load on the corresponding axis.
 (Action 2) Check whether the load settings are valid.
 (Action 3) Check whether the brake of the corresponding axis is released.
 (Action 4) If the load weight exceeds the rated range, decrease it to within the limit.
 (Action 5) Check whether the voltage input to the controller is within the rated voltage and check whether the voltage set for the transformer of the controller is correct.
 (Action 6) Replace the servo amplifier.
 (Action 7) Replace the motor of the corresponding axis.
 (Action 8) Replace the E-stop unit.
 (Action 9) Replace the motor power line (robot connection cable) of the corresponding axis.
 (Action 10) Replace the motor power line and brake line (inside the mechanical section) of the corresponding axis.
- (29) SRVO-051 CUER alarm (Group: i Axis: j)
 (Explanation) The offset of the current feedback value is abnormally high.
 (Action) Replace the servo amplifier.

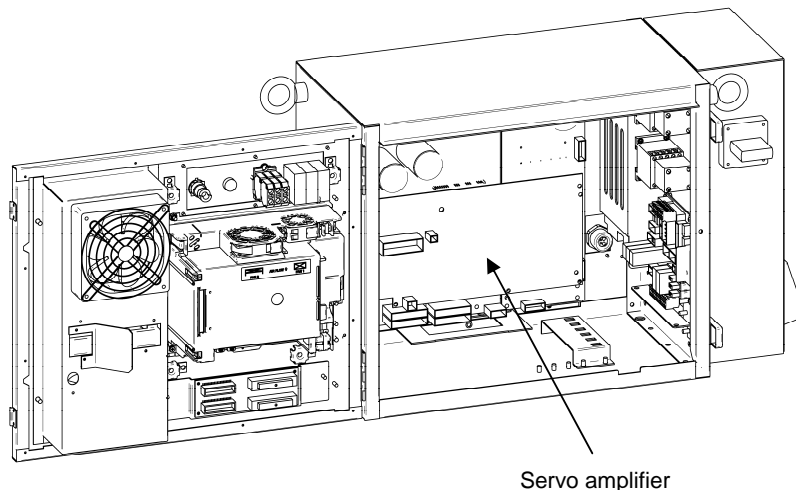
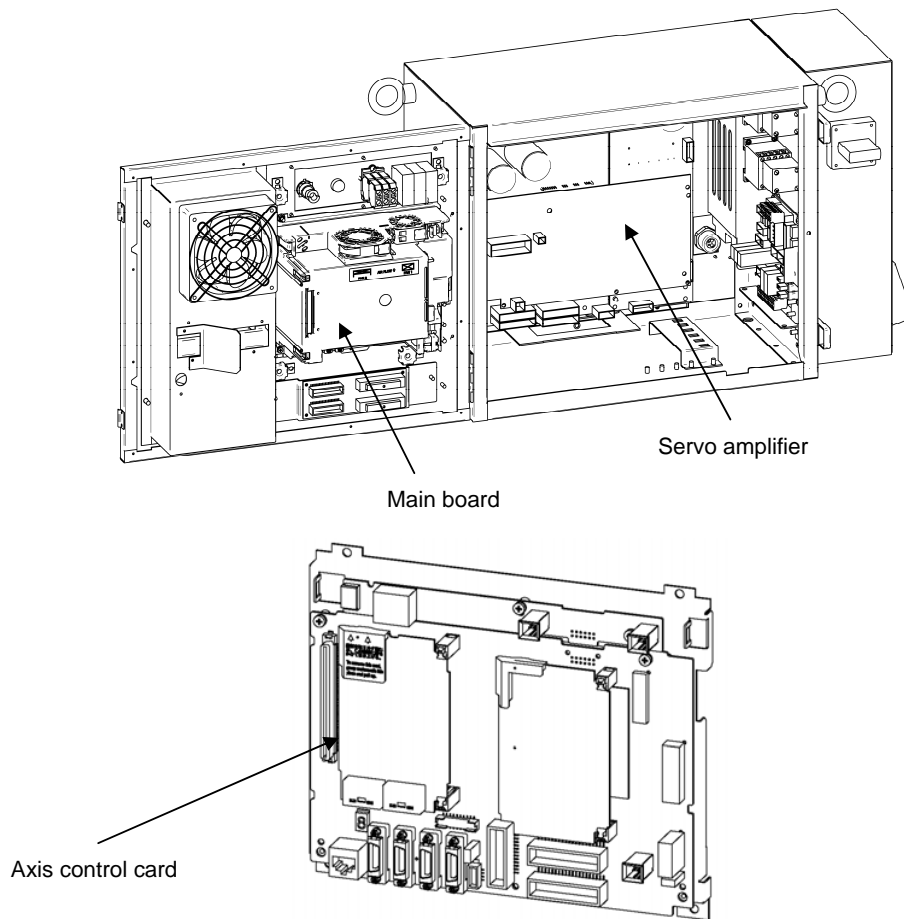


Fig.3.5 (p) SRVO-047 LVAL alarm
SRVO-050 CLALM alarm
SRVO-051 CUER alarm

- (30) SRVO-055 FSSB com error 1 (Group: i Axis : j)
 (Explanation) A communication error has occurred between the main board and servo amplifier.
 (Action 1) Check the communication cable (optical fiber) between the main board and servo amplifier. Replace it if it is faulty.
 (Action 2) Replace the axis control card on the main board.
 (Action 3) Replace the servo amplifier.
- (31) SRVO-056 FSSB com error 2 (Group: i Axis: j)
 (Explanation) A communication error has occurred between the main board and servo amplifier.
 (Action 1) Check the communication cable (optical fiber) between the main board and servo amplifier. Replace it if it is faulty.
 (Action 2) Replace the axis control card on the main board.
 (Action 3) Replace the servo amplifier.
- (32) SRVO-057 FSSB disconnect (Group: i Axis: j)
 (Explanation) Communication was interrupted between the main board and servo amplifier.
 (Action 1) Check whether fuses FS1 and FS3 in the servo amplifier have blown. If the fuse has blown, replace the servo amplifier including the fuse.
 (Action 2) Replace the optical cable between the axis control card and servo amplifier.
 (Action 3) Replace the axis control card on the main board.
 (Action 4) Replace the servo amplifier.
 (Action 5) Check for a point where the robot connection cable(RMP) or an internal cable running to each Pulsecoder through the robot mechanical section is grounded.
 Before continuing to the next step, perform a complete controller back-up to save all your programs and settings.
 (Action 6) Replace the main board.
- (33) SRVO-058 FSSB init error (Group: i Axis: j)
 (Explanation) Communication was interrupted between the main board and servo amplifier.
 (Action 1) Check whether fuse FS1 on the servo amplifier has blown. If the fuse has blown, replace the servo amplifier including the fuse.
 (Action 2) Turn off the power and disconnect the CRF8 connector on the servo amplifier. Then check whether this alarm occurs again. (Ignore the alarm SRVO-068 because of disconnecting the CRF8 connector.)

- If this alarm does not occur, the RMP cable of the robot connection cable or the internal cable of the robot may be short-circuited to the ground. Check the cables and replace it if necessary.
- (Action 3) Check whether the LED (P5V and P3.3V) on the servo amplifier is lit. If they are not lit, the DC power is not supplied to the servo amplifier.
Make sure the connector CRP24 and CRM96 on the E-stop unit and the connector CRM96 on the servo amplifier are connected tightly. If they are connected tightly, replace the servo amplifier.
- (Action 4) Check the communication cable (optical fiber) between the axis control board and servo amplifier. Replace it if it is faulty.
- (Action 5) Replace the servo card on the main board.
- (Action 6) Replace the servo amplifier.
- (Action 7) If the other units (the servo amplifier for the auxiliary axis and the line tracking interface) are connected in the FSSB optical communication, disconnect these units and connect only servo amplifier for the robot. Then turn on the power. If this alarm does not occur, search the failed unit and replace it.
- Before executing the (Action 8), perform a complete controller back-up to save all your programs and settings.
- (Action 8) Replace the main board.



**Fig.3.5 (q) SRVO-055 FSSB com error 1
SRVO-056 FSSB com error 2
SRVO-057 FSSB disconnect
SRVO-058 FSSB init error**

- (34) SRVO-059 Servo amp init error
 (Explanation) Servo amplifier initialization is failed.
 (Action 1) Check the wiring of the servo amplifier.
 (Action 2) Replace the servo amplifier.
 (Action 3) Replace the line tracking board.
- (35) SRVO-062 BZAL alarm (Group : i Axis : j)
 (Explanation) This alarm occurs if battery for Pulsecoder absolute-position backup is empty. A probable cause is a broken battery cable or no batteries in the robot.
 (Action 1) Replace the battery in the battery box of the robot base.
 (Action 2) Replace the Pulsecoder with which an alarm has been issued.
 (Action 3) Check whether the robot internal cable for feeding power from the battery to the Pulsecoder is not disconnected and grounded. If an abnormality is found, replace the cable.

**CAUTION**

After correcting the cause of this alarm, set the system variable (\$MCR.\$SPC_RESET) to TRUE then turn on the power again. Mastering is needed.

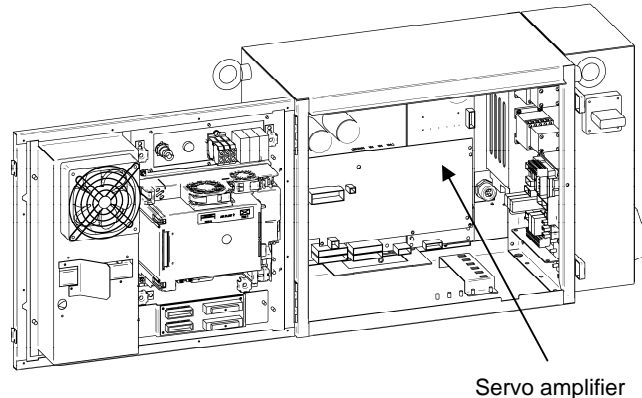
- (36) SRVO-064 PHAL alarm (Group : i Axis : j)
 (Explanation) This alarm occurs if the phase of the pulses generated in the Pulsecoder is abnormal.
 (Action) Replace the Pulsecoder.

NOTE

This alarm might accompany the DTERR, CRCERR, or STBERR alarm. In this case, however, there is no actual condition for this alarm.

- (37) SRVO-065 BLAL alarm (Group : i Axis : j)
 (Explanation) The battery voltage for the Pulsecoder is lower than the rating.
 (Action) Replace the battery.
 (If this alarm occurs, turn on the power and replace the battery as soon as possible. A delay in battery replacement may result in the BZAL alarm being detected. In this case, the position data will be lost. Once the position data is lost, mastering will become necessary.)
- (38) SRVO-067 OHAL2 alarm (Group : i Axis : j)
 (Explanation) The temperature inside the Pulsecoder or motor is abnormally high, and the built-in thermostat has operated.
 (Action 1) Check the robot operating conditions. If a condition such as the duty cycle and load weight has exceeded the rating, relax the robot load condition to meet the allowable range.
 (Action 2) When power is supplied to the motor after it has become sufficiently cool, if the alarm still occurs, replace the motor.
- (39) SRVO-068 DTERR alarm (Group : i Axis : j)
 (Explanation) The serial Pulsecoder does not return serial data in response to a request signal.
 (Action 1) Make sure that the RMP connector of servo amplifier (motor side) is connected tightly.
 (Action 2) Check that the shielding of the RMP cable is grounded securely in the cabinet.
 (Action 3) Replace the Pulsecoder.
 (Action 4) Replace the servo amplifier.
 (Action 5) Replace the RMP cable.
 (Action 6) Replace the robot interconnection cable (for the Pulsecoder).

- (40) SRVO-069 CRCERR alarm (Group : i Axis : j)
 (Explanation) The serial data has disturbed during communication.
 (Action) See actions on SRVO-068.
- (41) SRVO-070 STBERR alarm (Group : i Axis : j)
 (Explanation) The start and stop bits of the serial data are abnormal.
 (Action) See actions on SRVO-068.



**Fig.3.5 (r) SRVO-059 Servo amp init error
 SRVO-070 STBERR alarm**

- (42) SRVO-071 SPHAL alarm (Group : i Axis : j)
 (Explanation) The feedback speed is abnormally high.
 (Action) Action as same as the SRVO-068.

NOTE

If this alarm occurs together with the PHAL alarm (SRVO-064), this alarm does not correspond to the major cause of the failure.

- (43) SRVO-072 PMAL alarm (Group : i Axis : j)
 (Explanation) It is likely that the Pulsecoder is abnormal.
 (Action) Replace the Pulsecoder and remaster the robot.
- (44) SRVO-073 CMAL alarm (Group : i Axis : j)
 (Explanation) It is likely that the Pulsecoder is abnormal or the Pulsecoder has malfunctioned due to noise.
 (Action 1) Check whether the connection of the controller earth is good. Check the earth cable connection between controller and robot. Check whether the shielding of the robot connection cables is connected securely to the grounding plate.
 (Action 2) Reinforce the earth of the motor flange.(In case of Auxiliary axis)
 (Action 3) Replace the Pulsecoder.
- (45) SRVO-074 LDAL alarm (Group : i Axis : j)
 (Explanation) The LED in the Pulsecoder is broken.
 (Action) Replace the Pulsecoder, and remaster the robot.
- (46) SRVO-075 Pulse not established (Group : i Axis : j)
 (Explanation) The absolute position of the Pulsecoder cannot be established.
 (Action) Reset the alarm, and jog the axis on which the alarm has occurred until the same alarm will not occur again.
- (47) SRVO-076 Tip Stick Detection (Group : i Axis : j)

- (Explanation) An excessive disturbance was assumed in servo software at the start of operation. (An abnormal load was detected. The cause may be welding.)
- (Action 1) Check whether the robot has collided. Or check whether the machinery load of the corresponding axis is increased.
- (Action 2) Check whether the load settings are valid.
- (Action 3) Check whether the brake of the corresponding axis is released.
- (Action 4) Check whether the load weight is within the rated range. If the weight exceeds the upper limit, decrease it to the limit.
- (Action 5) Check whether the voltage input to the controller is within the rated voltage and check whether the voltage set for the transformer of the controller is correct.
- (Action 6) Replace the servo amplifier.
- (Action 7) Replace the corresponding servo motor.
- (Action 8) Replace the E-stop unit.
- (Action 9) Replace the power cable of the robot connection cable in which the corresponding axis is connected.
- (Action 10) Replace the power cable of the robot interconnection cable in which the corresponding axis is connected.

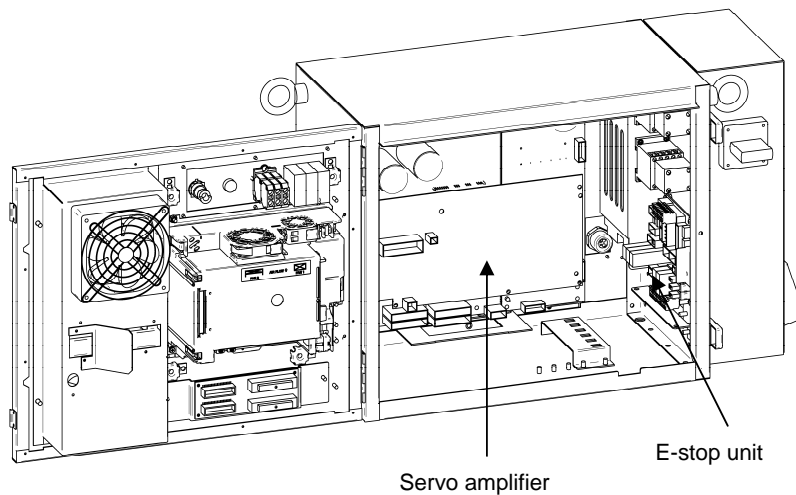


Fig.3.5 (s) SRVO-076 Tip Stick Detection

- (48) SRVO-081 EROFL alarm (Track enc : i)
- (Explanation) The pulse counter for line tracking has overflowed.
- (Action 1) Check whether the condition of the line tracking exceeds the limitation.
- (Action 2) Replace the Pulsecoder.
- (Action 3) Replace the line tracking interface board.
- (49) SRVO-082 DAL alarm (Track ebc : i)
- (Explanation) The line tracking Pulsecoder has not been connected.
- (Action 1) Check the connection cable at each end (the line tracking interface board and the motor side)
- (Action 2) Check whether the shielding of the connection cable is connected securely to the grounding plate.
- (Action 3) Replace the line tracking cable.
- (Action 4) Replace the Pulsecoder.
- (Action 5) Replace the line tracking interface board.
- (50) SRVO-084 BZAL alarm (Track enc : i)
- (Explanation) This alarm occurs if the backup battery for the absolute position of the Pulsecoder has not been connected. See the description about the BZAL alarm (SRVO-062).

- (51) SRVO-087 BLAL alarm (Track enc : i)
(Explanation) This alarm occurs if the voltage of the backup battery for the absolute position of the Pulsecoder is low. See the description about the BLAL alarm (SRVO-065).
- (52) SRVO-089 OHAL2 alarm (Track enc : i)
(Explanation) The motor has overheated. When power is supplied to the Pulsecoder after it has become sufficiently cool, if the alarm still occurs. See the description about the OHAL2 alarm (SRVO-067).
- (53) SRVO-090 DTERR alarm (Track enc : i)
(Explanation) Communication between the Pulsecoder and line tracking interface board is abnormal. See the SRVO-068 DTERR alarm.
(Action 1) Check the connection cable at each end (the line tracking interface board and the Pulsecoder)
(Action 2) Check whether the shielding of the connection cable is connected securely to the grounding plate.
(Action 3) Replace the Pulsecoder.
(Action 4) Replace the line tracking cable.
(Action 5) Replace the line tracking interface board.
- (54) SRVO-091 CRCERR alarm (Track enc : i)
(Explanation) Communication between the Pulsecoder and line tracking interface board is abnormal.
(Action) Action as same as the SRVO-090.
- (55) SRVO-092 STBERR alarm (Track enc : i)
(Explanation) Communication between the Pulsecoder and line tracking interface board is abnormal.
(Action) Action as same as the SRVO-090.
- (56) SRVO-093 SPHAL alarm (Track enc : i)
(Explanation) This alarm occurs if the current position data from the Pulsecoder is higher than the previous position data.
(Action) Action as same as the SRVO-090.
- (57) SRVO-094 PMAL alarm (Track enc : i)
(Explanation) It is likely that the Pulsecoder is abnormal. See the description about the PMAL alarm (SRVO-072).
- (58) SRVO-095 CMAL alarm (Track enc : i)
(Explanation) It is likely that the Pulsecoder is abnormal or the Pulsecoder has malfunctioned due to noise. See the description about the CMAL alarm (SRVO-073).
(Action 1) Reinforce the earth of the flange of the Pulsecoder.
(Action 2) Replace the Pulsecoder.
- (59) SRVO-096 LDAL alarm (Track enc : i)
(Explanation) The LED in the Pulsecoder is broken. See the description about the LDAL alarm (SRVO-074).
- (60) SRVO-097 Pulse not established (enc : i)
(Explanation) The absolute position of the Pulsecoder cannot be established. See the description about (SRVO-075). Pulse not established.
(Action 1) Reset the alarm, and jog the axis on which the alarm has occurred until the same alarm does not occur again. (Jog one motor revolution)

(61) SRVO-105 Door open or E-stop

- (Explanation) The cabinet door is open.
- When the door switch is mounted.
- (Action 1) When the door is open, close it.
- (Action 2) Check the door switch and door switch connection cable. If the switch or cable is faulty, replace it.
- When the door switch is not mounted.
- (Action 3) Check that the CRMA31, CRMA43, and CRM90 connectors on the E-STOP unit are connected securely.
- (Action 4) Replace the E-stop unit.
- (Action 5) Replace the servo amplifier.

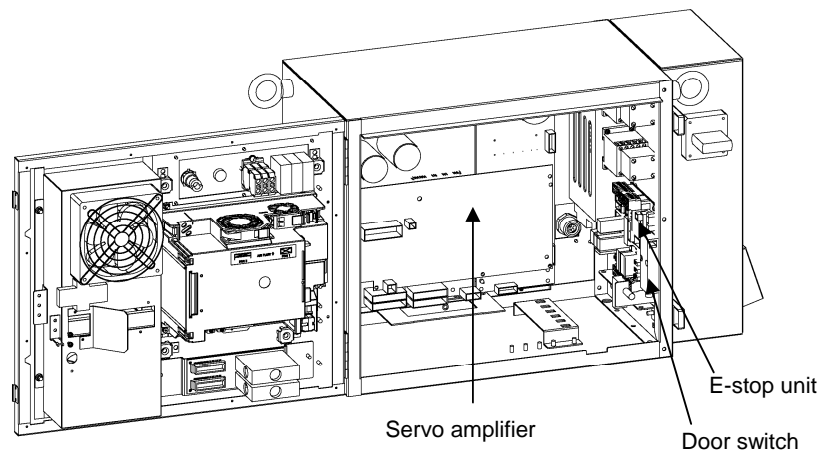
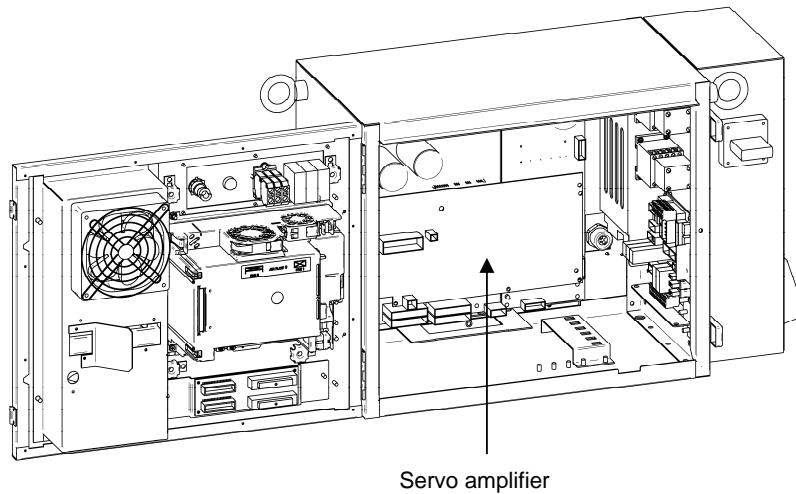


Fig.3.5 (t) SRVO-105 Door open or E-stop

(62) SRVO-136 DCLVAL alarm (Group : i Axis : j)

- (Explanation) The servo the DC current of amplifier (DC link voltage) of the main power supply is abnormally low.
- This alarm occurred during robot operation.
- (Action 1) Check the input voltage to the controller is within the rated voltage and no phase is lack. In addition, check the setting of the transformer is correct.
- (Action 2) It is possible that an instant disconnection of power source causes this alarm. Check whether an instant disconnection occurred.
- (Action 3) Modify the program in order that robot and the auxiliary axis do not accelerate simultaneously in the system with the auxiliary axis.
- (Action 4) Replace the E-stop unit.
- (Action 5) Replace the servo amplifier.
- If this alarm occurred before the magnetic contactor is turned on:
- (Action 1) Check whether the circuit breaker in the E-stop unit is OFF. If it is OFF, check the servo amplifier and the wiring between the servo amplifier and the E-stop unit. If anything is abnormal, replace it. Else, turn on the breaker.
- (Action 2) Check the input voltage to the controller is within the rated voltage and no phase is lack. In addition, check the setting of the transformer is correct.
- (Action 3) Replace the E-stop unit.
- (Action 4) Replace the servo amplifier.

- (63) SRVO-156 IPMAL alarm (Group: i Axis: j)
 (Explanation) Abnormally high current flowed through the main circuit of the servo amplifier.
 (Action 1) Turn off the power, and disconnect the power cable from the servo amplifier indicated by the alarm message. (And disconnect the brake cable (CRR88) on the servo amplifier to avoid the axis falling unexpectedly.) Turn on the power, and if the alarm occurs again, replace the servo amplifier.
 (Action 2) Turn off the power and disconnect the power cable from the servo amplifier indicated by the alarm message, and check the insulation of their U, V, W and the GND lines each other. If there is a short-circuit, replace the power cable.
 (Action 3) Turn off the power and disconnect the power cable from the servo amplifier by the alarm message, and measure the resistance between their U and V, V and W and W and U with an ohmmeter that has a very low resistance range. If the resistances at the three places are different from each other, the motor, the power cable is defective. Check each item in detail and replace it if necessary.
- (64) SRVO-157 CHGAL alarm (Group : i Axis : j)
 (Explanation) The capacitor for the condenser voltage of the servo amplifier was not charged within the specified time when the servo power is on.
 (Action 1) Replace the E-stop unit.
 (Action 2) Replace the servo amplifier.
 (Action 3) Replace the auxiliary amplifier for system of the auxiliary axis.



**Fig.3.5 (u) SRVO-136 DCLVAL alarm
 SRVO-156 IPMAL alarm
 SRVO-157 CHGAL alarm**

(65) SRVO-201 Panel E-stop or SVEMG abnormal

(Explanation) The EMERGENCY STOP button on the operator's panel was pressed, but the EMERGENCY STOP line was not disconnected.

(Action 1) With the E-stop in the released position, check for continuity across the terminals of the switch. If continuity is not found, the emergency stop button is broken. Replace the switch unit or the operator's panel.

Before executing the (Action 2), perform a complete controller back-up to save all your programs and settings.

(Action 2) Replace the main board.

(Action 3) Replace the Servo amplifier.

(Action 4) Replace the E-stop board.

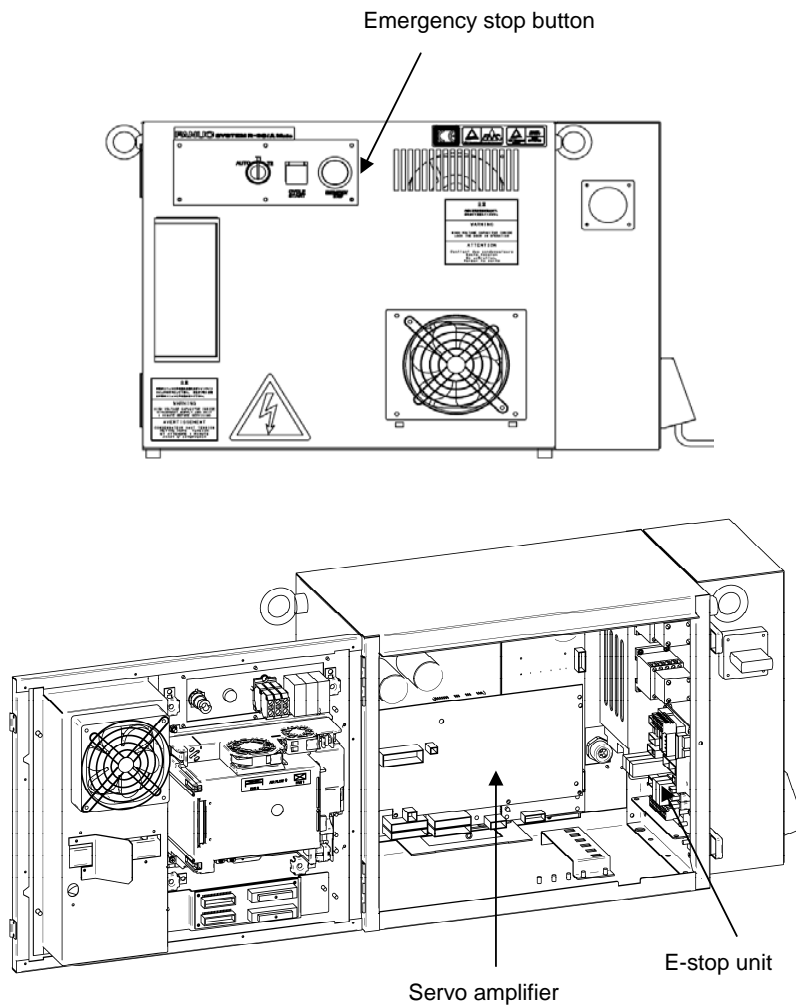


Fig.3.5 (v) SRVO-201 Panel E-stop or SVEMG abnormal

(66) SRVO-202 TP E-stop or SVEMG abnormal

(Explanation) The EMERGENCY STOP button on the teach pendant was pressed, but the EMERGENCY STOP line was not disconnected.

(Action 1) Replace the teach pendant.

(Action 2) Check the teach pendant cable. If this inferior, replace the cable.

(Action 3) Replace the operator's panel.

(Action 4) Replace the E-stop unit.

(Action 5) Replace the servo amplifier.

NOTE

This alarm might occur if the EMERGENCY STOP button is pressed slowly.

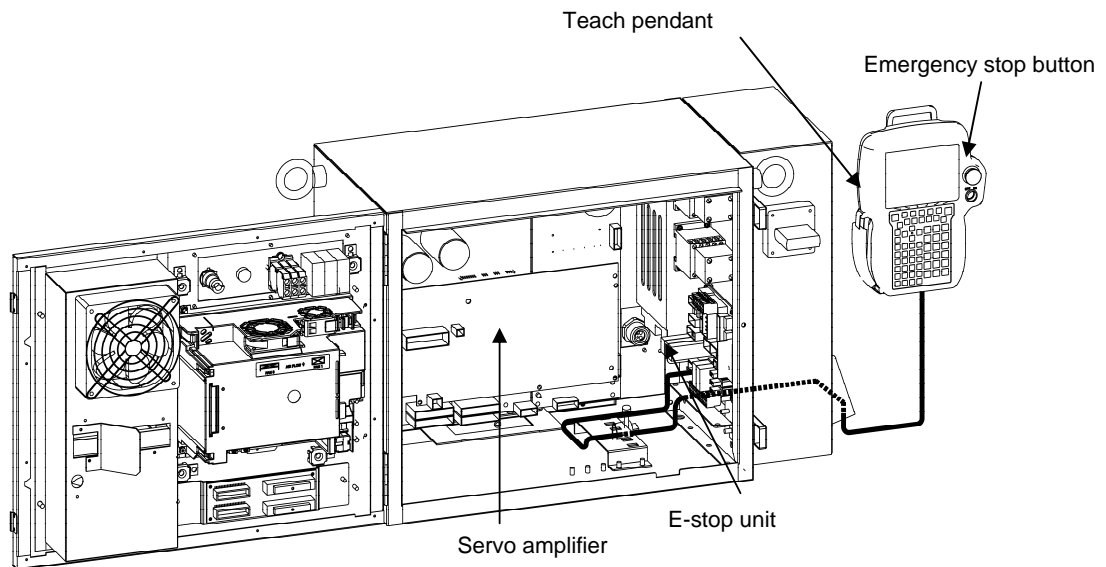
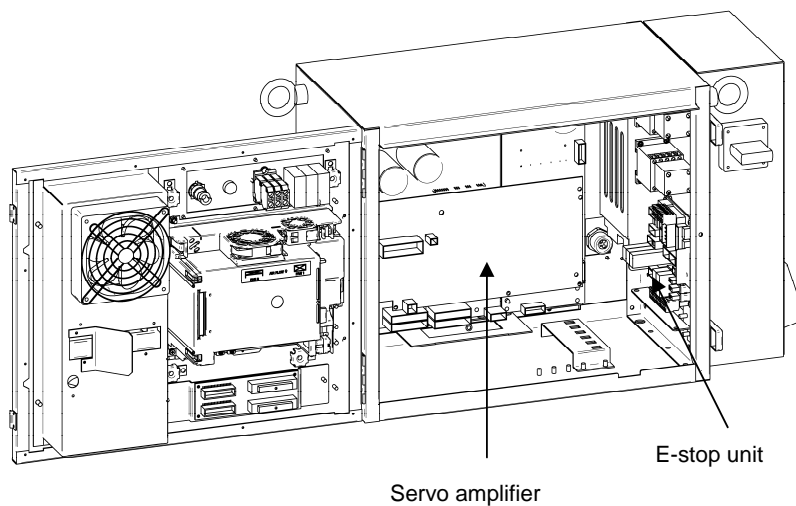


Fig.3.5 (w) SRVO-202 TP E-stop or SVEMG abnormal

- (67) SRVO-204 External (SVEMG abnormal) E-stop
 (Explanation) The emergency stop line was not disconnected when the switch connected to the external emergency stop contacts on the E-stop board was pressed.
 Terminal connection: Between EES1 and EES11 and between EES2 and EES21 on the TBOP7 terminal board.
- (Action 1) Check the switches and cables connected between terminals on the E-stop board (between EES1 and EES11 and between EES2 and EES21 on TBOP7). If a defective cable or switch is found, replace it.
- (Action 2) Replace the E-stop unit.
- (Action 3) Replace the servo amplifier.
- (68) SRVO-205 Fence open (SVEMG abnormal)
 (Explanation) The emergency stop line was not disconnected when the switch connected to the safety fence contacts on the E-stop board was pressed.
 Terminal connection: Between EAS1 and EAS11 and between EAS2 and EAS21 on the TBOP7 terminal board.
- (Action 1) Check the switches and cables connected between terminals on the E-stop board (between EAS1 and EAS11 and between EAS2 and EAS21 on TBOP7). If a defective cable or switch is found, replace it.
- (Action 2) Replace the E-stop unit.
- (Action 3) Replace the servo amplifier.



(E-stop board)

**Fig.3.5 (x) SRVO-204 External (SVEMG abnormal) E-stop
 SRVO-205 Fence open (SVEMG abnormal)**

(69) SRVO-206 DEADMAN switch (SVEMG abnormal)

(Explanation) When the teach pendant was enabled, the DEADMAN switch was released or pressed strongly, but the emergency stop line was not disconnected.

(Action 1) Replace the teach pendant.

(Action 2) Check the teach pendant cable. If it is inferior, replace the cable.

(Action 3) Replace the E-stop unit.

(Action 4) Replace the servo amplifier.

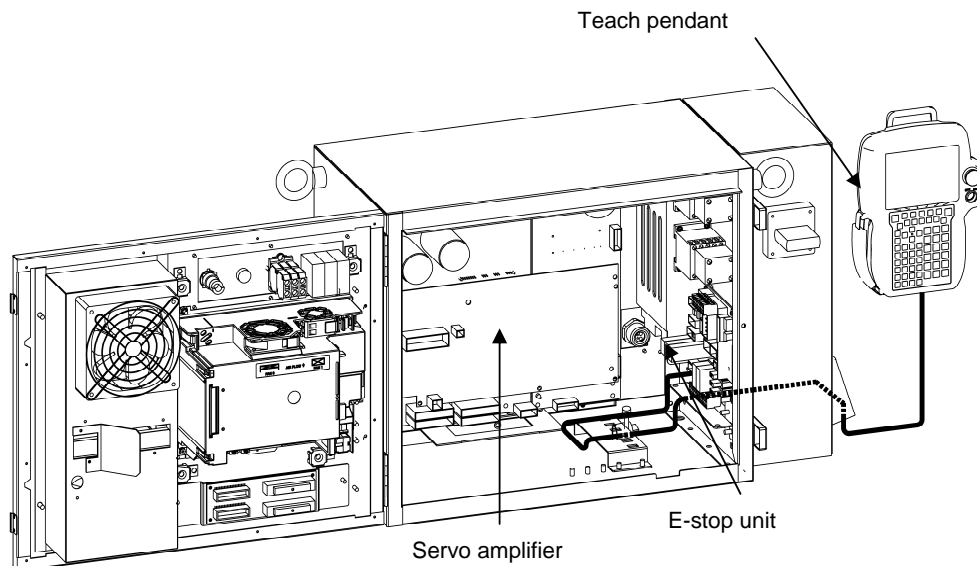
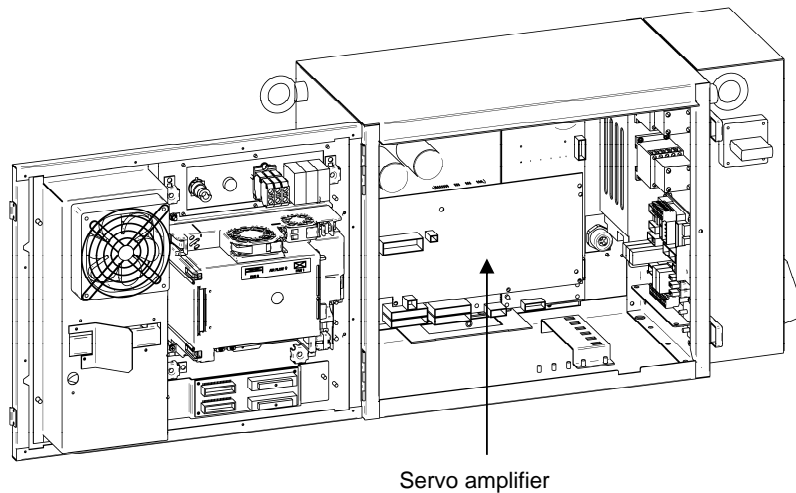


Fig.3.5 (y) SRVO-206 DEADMAN switch (SVEMG abnormal)

- (70) SRVO-214 Fuse blown (Servo amplifier)
(Explanation) A fuse in the servo amplifier has blown.
In case that FS1 is blown
(Action 1) Replace the servo amplifier.
In case that FS2 or FS3 is blown
(Action 1) A fuse is blown, eliminate the cause, and then replace the fuse. (See Section 3.6 in the Part II, "MAINTENANCE".)
(Action 2) Replace the servo amplifier.
- (71) SRVO-216 OVC (total) (Robot : i)
(Explanation) The current (total current for six axes) flowing through the motor is too large.
(Action 1) Slow the motion of the robot where possible. Check the robot operation conditions.
If the robot is used with a condition exceeding the duty or load weight robot rating, reduce the load condition value to the specification range.
(Action 2) Check the input voltage to the controller is within the rated voltage and no phase is lack. In addition, check the setting of the transformer is correct.
(Action 3) Replace the servo amplifier.



**Fig.3.5 (z) SRVO-214 Fuse blown (servo amplifier)
SRVO-216 OVC (total)**

(72) SRVO-218 Ext.E-stop/ServoDisconnect

(Explanation) The switch connected across EES1 – EES11 and EES2 – EES21 on the TBOP7 terminal board on the E-stop board was pressed.

(Action 1) When the external emergency stop button is connected, release the button.

(Action 2) Check the switch and cable connected to EES1 – EES11 and EES2 – EES21 on TBOP7 terminal board. If the cable is abnormal, replace it.

(Action 3) When this signal is not used, establish the short circuits between the contacts (between EES1 – EES11 and between EES2 – EES21) on the terminal block of the E-stop unit.

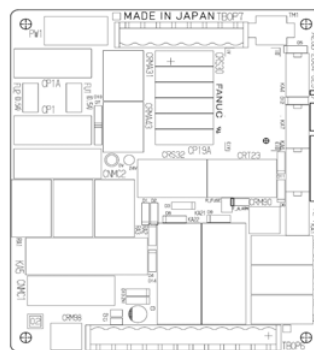
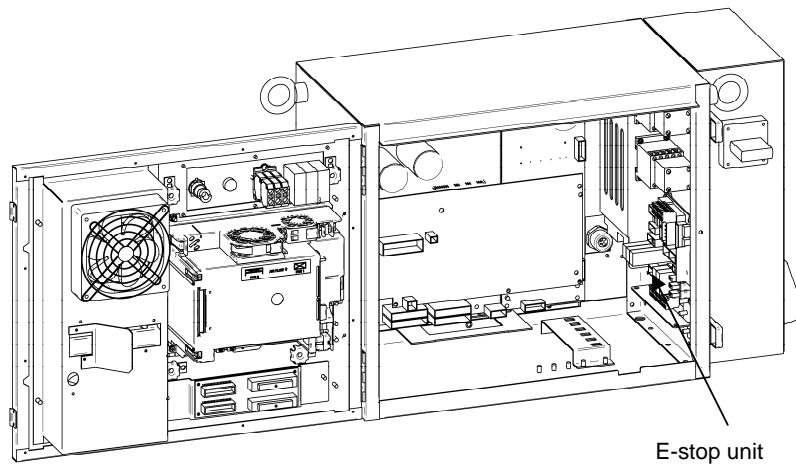
(Action 4) Replace the teach pendant.

(Action 5) Check the teach pendant cable. If this inferior, replace the cable.

(Action 6) Replace the E-stop unit.

Before executing the (Action 7), perform a complete controller back-up to save all your programs and settings.

(Action 7) Replace the main board.

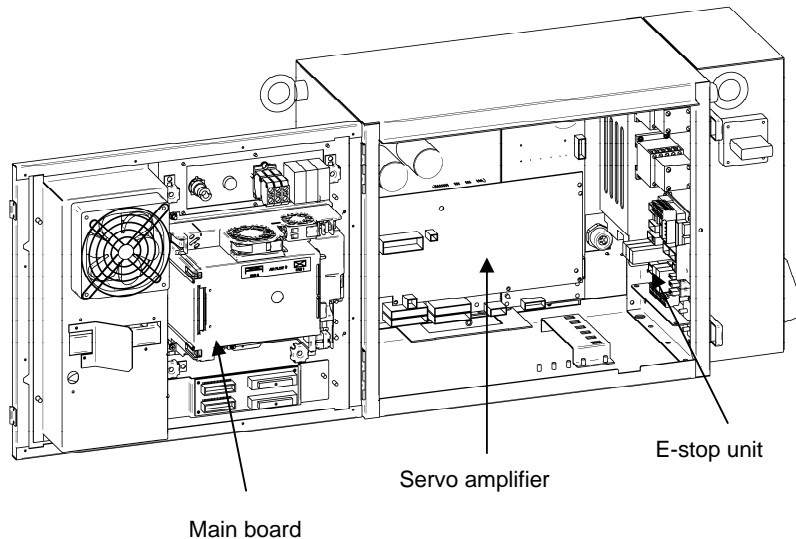


(E-stop board)

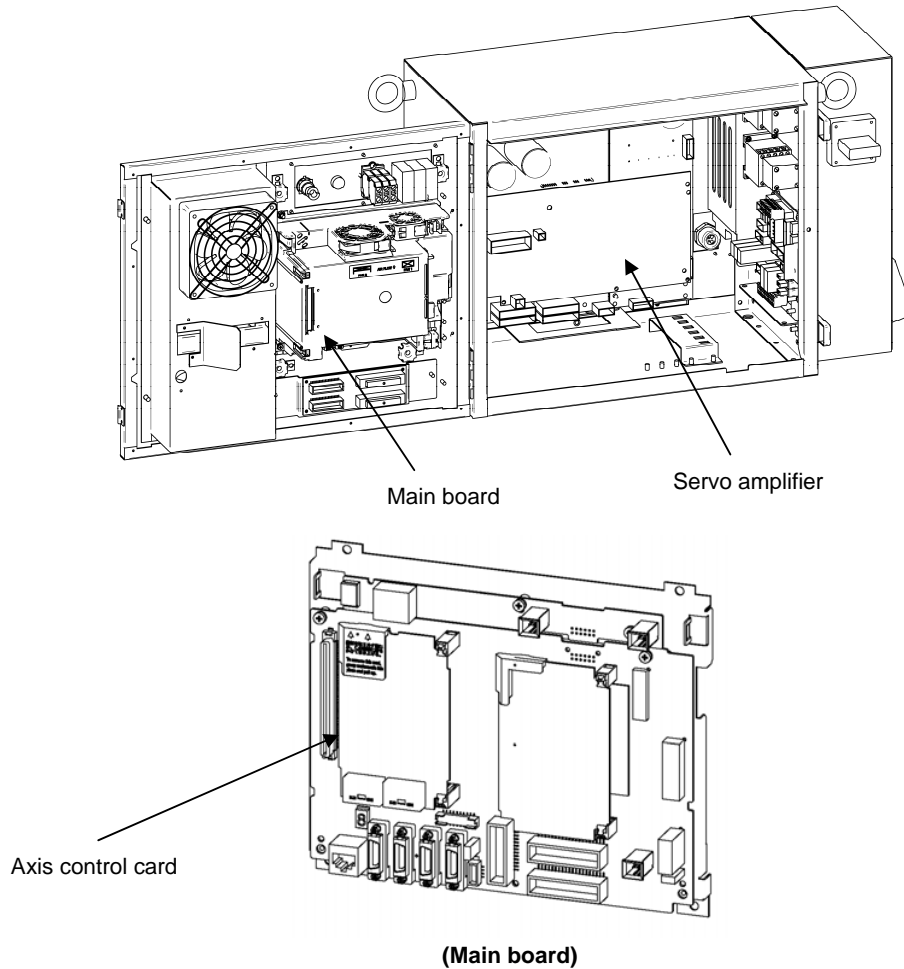
Fig.3.5 (aa) SRVO-218 Ext.E-stop/ServoDisconnect

(73) SRVO-220 SDI fuse blown

- (Explanation) A fuse (FUSE3) on the main board has blown.
- (Action 1) Check whether the fuse (FUSE3) on the main board has blown. If the fuse has blown, 24SDI may be short-circuited to 0V. Take Action 2.
- (Action 2) Remove the cause of the 24SDI ground-fault, then check that FUSE3 does not blow. Disconnect the following on the main board, then turn on the power.
- CRMA15
 - CRMA16
- If FUSE3 does not blow in this state, 24SDI and 0V may be short-circuited at any of the above locations. Determine the faulty location, then take appropriate action.
- If FUSE3 still blows after the above are disconnected, take Action 3.
- (Action 3) Disconnect CRS30. If FUSE3 still blows, replace the main board.
- (Action 4) Replace the cable between the E-stop unit and servo amplifier.
- (Action 5) Replace the cable between the main board and the E-stop unit.
- (Action 6) Replace the E-stop unit.
- (Action 7) Replace the servo amplifier

**Fig.3.5 (ab) SRVO-220 SDI fuse blown**

- (74) SRVO-221 Lack of DSP (Group : i Axis : j)
 (Explanation) A controlled axis card corresponding to the set number of axes is not mounted.
 (Action 1) Check whether the set number of axes is valid. If the number is invalid, set the correct number.
 (Action 2) Replace the axis control card with a card corresponding to the set number of axes.
- (75) SRVO-223 DSP dry run(a b)
 (Explanation) Servo system initialization was stopped because of a hardware failure or improper software setting. The controller has been started in the DSP dry run mode.
 (Action 1) When the value is 1, 5, or 6: An incorrect setting is made. Check whether the dry run mode is set and also check whether the setting of the hard start axis is correct.
 (Action 2) When the value is 2, 3, 4, or 7: Replace the servo card.
 (Action 3) When the value is 8 or 10: Take action for an FSSB initialization error that has occurred at the same time.
 (Action 4) When the value is 9: Take the following action:
 Check whether the servo amplifier is connected.
 Replace the optical cable used for servo amplifier connection.
 Replace the servo amplifier



**Fig.3.5 (ac) SRVO-221 Lack of DSP
 SRVO-223 DSP dry run(a b)**

- (76) SRVO-230 Chain 1 abnormal a,b
 SRVO-231 Chain 2 abnormal a,b

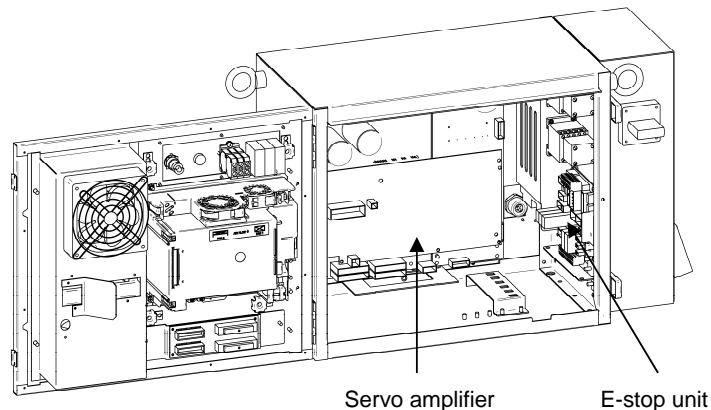
(Explanation) A mismatch occurred between duplicate safety signals. SRVO-230 is issued if such a mismatch that a contact connected on the chain 1 side (between EES1 and EES11, between EAS1 and EAS11, between SD4 and SD41, and so forth) is closed, and a contact on the chain 2 side (between EES2 and EES21, between EAS2 and EAS21, between SD5 and SD51, and so forth) is open occurs. SRVO-231 is issued if such a mismatch that a contact on the chain 1 side is open, and a contact on the chain 2 side is closed occurs.

If a chain error is detected, correct the cause of the alarm then reset the alarm according to the method described later.

(Action) Check the alarms issued at the same time in order to identify with which signal the mismatch occurred. SRVO-266 through SRVO-275 and SRVO-370 through SRVO-385 are issued at the same time. Take the action(s) described for each item.

⚠ WARNING

If this alarm is issued, do not reset the chain error alarm until the failure is identified and repaired. If robot use is continued with one of the duplicate circuits being faulty, safety may not be guaranteed when the other circuit fails.



**Fig.3.5 (ad) SRVO-230 Chain 1 abnormal
 SRVO-231 Chain 2 abnormal**

⚠ CAUTION

- 1 The state of this alarm is preserved by software. After correcting the cause of the alarm, reset the chain error alarm according to the chain error reset procedure described later.
- 2 Until a chain error is reset, no ordinary reset operation must be performed. If an ordinary reset operation is performed before chain error resetting, the message "SRVO-237 Chain error cannot be reset" is displayed on the teach pendant.

Alarm history display method

1. Press the screen selection key on the teach pendant.
2. Select [4 ALARM] on the teach pendant.
3. Press F3 [HIST] on the teach pendant.

Chain error reset procedure



CAUTION

Do not perform this operation until the cause of the alarm is corrected.

<Method 1>

1. Press the emergency stop button.
2. Press the screen selection key on the teach pendant.
3. Select [0 NEXT PAGE] on the teach pendant.
4. Press [6 SYSTEM] on the teach pendant.
5. Press [7 SYSTEM SETTING] on the teach pendant.
6. Find "28" Chain Error Reset Execution.
7. Press F3 on the teach pendant to reset "Chain Error".

<Method 2>

1. Press the screen selection key on the teach pendant.
2. Select [4 ALARM] on the teach pendant.
3. Press F4 [CHAIN RESET] on the teach pendant.

(77) SRVO-233 TP disabled in T1, T2/Door open

(Explanation) Teach pendant is disabled when the mode switch is T1 or T2.

(Action 1) Enable the teach pendant in teaching operation. In other case the mode switch should be AUTO mode.

(Action 2) Replace the teach pendant.

(Action 3) Replace the teach pendant cable.

(Action 4) Replace the mode switch.

(Action 5) Replace the E-stop unit.

(Action 6) Replace the servo amplifier.

(78) SRVO-235 Short term Chain abnormal

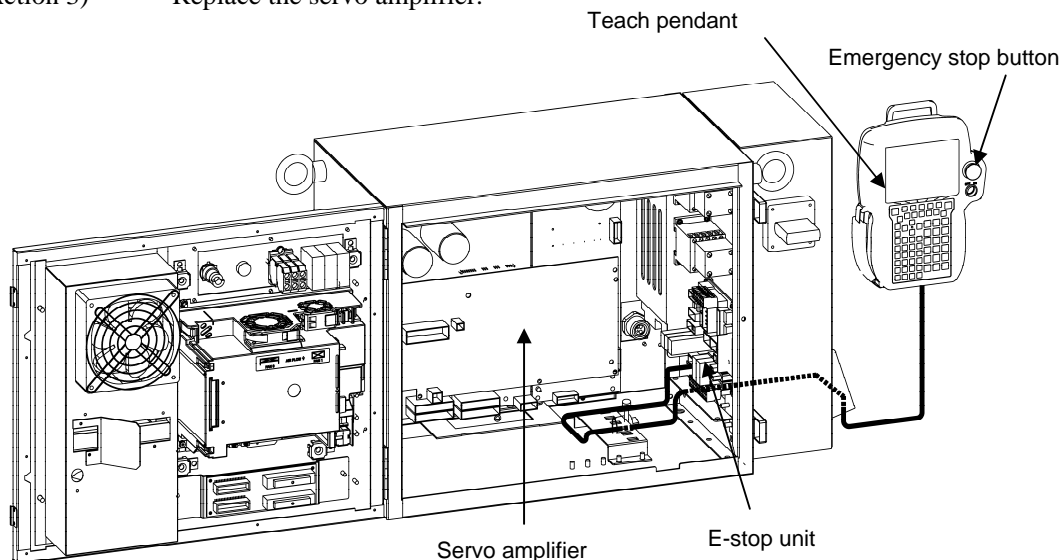
(Explanation) Short term single chain failure condition is detected.

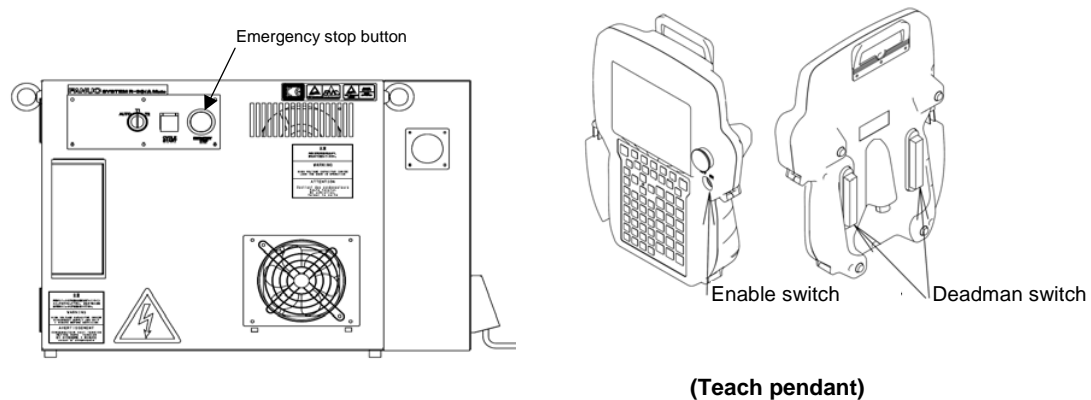
- Cause of this alarm is ;
 - Half release of DEADMAN switch
 - Half operation of emergency stop switch.

(Action 1) Cause the same error to occur again, then perform resetting.

(Action 2) Replace the E-stop unit.

(Action 3) Replace the servo amplifier.





**Fig.3.5 (ae) SRVO-233 TP disabled in T1, T2/Door open
SRVO-235 Short term Chain abnormal**

- (79) SRVO-251 DB relay abnormal
 (Explanation) An abnormality was detected in the internal relay (DB relay) of the servo amplifier.
 (Action) Replace the servo amplifier.
- (80) SRVO-252 Current detect abnl
 (Explanation) An abnormality was detected in the current detection circuit inside the servo amplifier.
 (Action) Replace the servo amplifier.
- (81) SRVO-253 Amp internal over heat
 (Explanation) An overheat was detected inside the servo amplifier.
 (Action) Replace the servo amplifier.
- (82) SRVO-266 FENCE1 status abnormal
 SRVO-267 FENCE2 status abnormal
 (Explanation) A chain alarm was detected with the EAS (FENCE) signal.
 (Action 1) Check whether the circuitry connected to the dual input signal (EAS) is faulty.
 (Action 2) Check whether the timing of the dual input signal (EAS) satisfies the timing specification (See Section 3.2.5, Table 3.2.5 of Part III CONNECTIONS).
- Before executing the (Action 3), perform a complete controller back-up to save all your programs and settings.
 (Action 3) Replace the main board.
 (Action 4) Replace the E-stop unit.



CAUTION

- 1 For the procedure of recovery from this alarm, see the descriptions of SRVO-230 and SRVO-231.
- 2 If this alarm is issued, do not reset the chain error alarm until the failure is checked and corrected. If robot use is continued with one of the duplicate circuits being faulty, safety may not be guaranteed when the other circuit fails.

- (83) SRVO-270 EXEMG1 status abnormal
SRVO-271 EXEMG2 status abnormal
- (Explanation) A chain alarm was detected with the EES (EXEMG) signal.
- (Action 1) Check whether the circuitry connected to the dual input signal (EES) is faulty.
- (Action 2) Check whether the timing of the dual input signal (EES) satisfies the timing specification
(See Section 3.2.5, Table 3.2.5 of Part III CONNECTIONS).
- (Action 3) Check the teach pendant cable. If this inferior, replace the cable.
- (Action 4) Replace the teach pendant.
- (Action 5) Check the emergency stop button connection and operation. If trouble is found, replace the emergency stop button.
- (Action 6) Replace the E-stop unit.
- Before executing the (Action 7), perform a complete controller back-up to save all your programs and settings.
- (Action 7) Replace the main board.

**CAUTION**

- 1 For the procedure of recovery from this alarm, see the descriptions of SRVO-230 and SRVO-231.
- 2 If this alarm is issued, do not reset the chain error alarm until the failure is checked and corrected. If robot use is continued with one of the duplicate circuits being faulty, safety may not be guaranteed when the other circuit fails.

(84) SRVO-277 Panel E-stop(SVEMG abnormal)

(Explanation) The E-stop line was not disconnected although the emergency stop button on the operator's panel was pressed.

Before executing the (Action 1), perform a complete controller back-up to save all your programs and settings.

(Action 1) Replace the main board.

(Action 2) Replace the E-stop unit

(Action 3) Replace the servo amplifier.

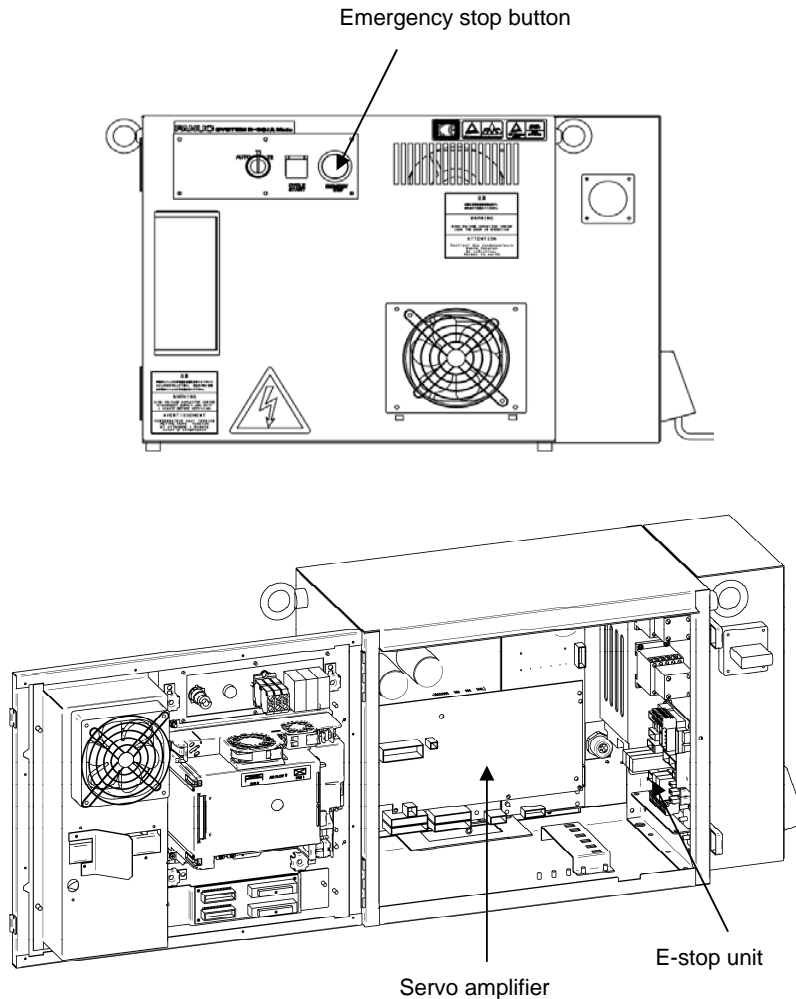


Fig.3.5 (af) SRVO-251 DB relay abnormal
SRVO-252 Current detect abnl
SRVO-253 Amp internal over heat
SRVO-266 FENCE1 status abnormal
SRVO-267 FENCE2 status abnormal
SRVO-270 EXEMG1 status abnormal
SRVO-271 EXEMG2 status abnormal
SRVO-277 Panel E-stop(SVEMG abnormal)

(85) SRVO-278 TP E-stop(SVEMG abnormal)

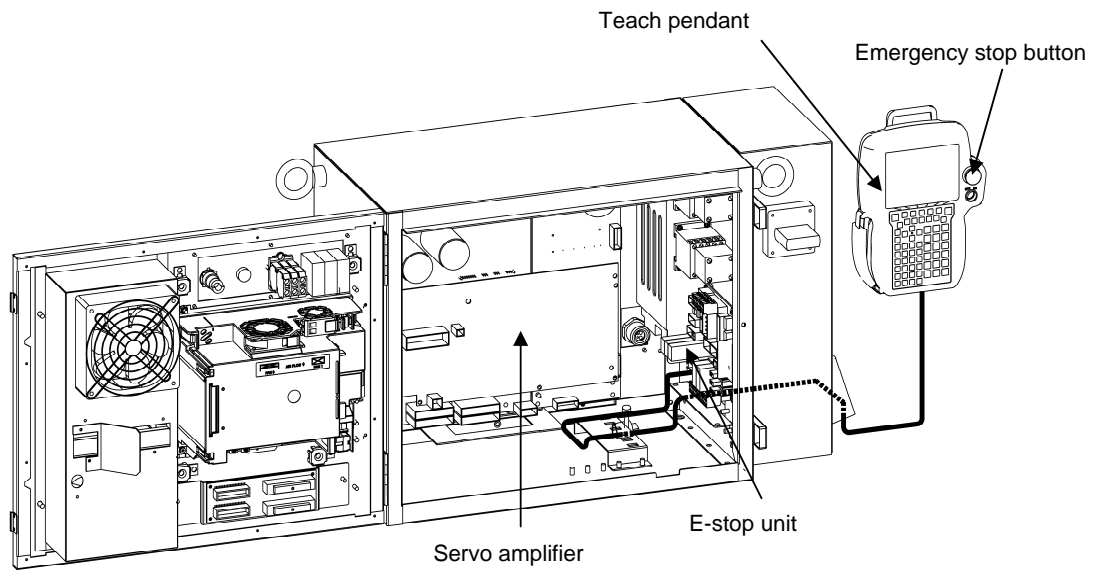
(Explanation) The emergency stop line was not disconnected although the emergency stop button on the teach pendant was pressed.

(Action 1) Replace the teach pendant.

(Action 2) Replace the teach pendant cable.

(Action 3) Replace the E-stop unit.

(Action 4) Replace the servo amplifier.

**NOTE**

This alarm may be issued if the emergency stop button is pressed very slowly.

Fig.3.5 (ag) SRVO-278 TP E-stop(SVEMG abnormal)

(86) SRVO-291 IPM over heat (G:i A:j)

(Explanation) IPM on the servo amplifier is overheated.

(Action 1) Check whether the fan for cabinet ventilation is stopped and also check whether the vent hole is clogged. If necessary, clean or replace them.

(Action 2) If SRVO-291 is issued when the robot operating condition is severe, check the robot operating condition then relax the condition when possible.

(Action 3) If SRVO-291 is issued frequently, replace the servo amplifier.

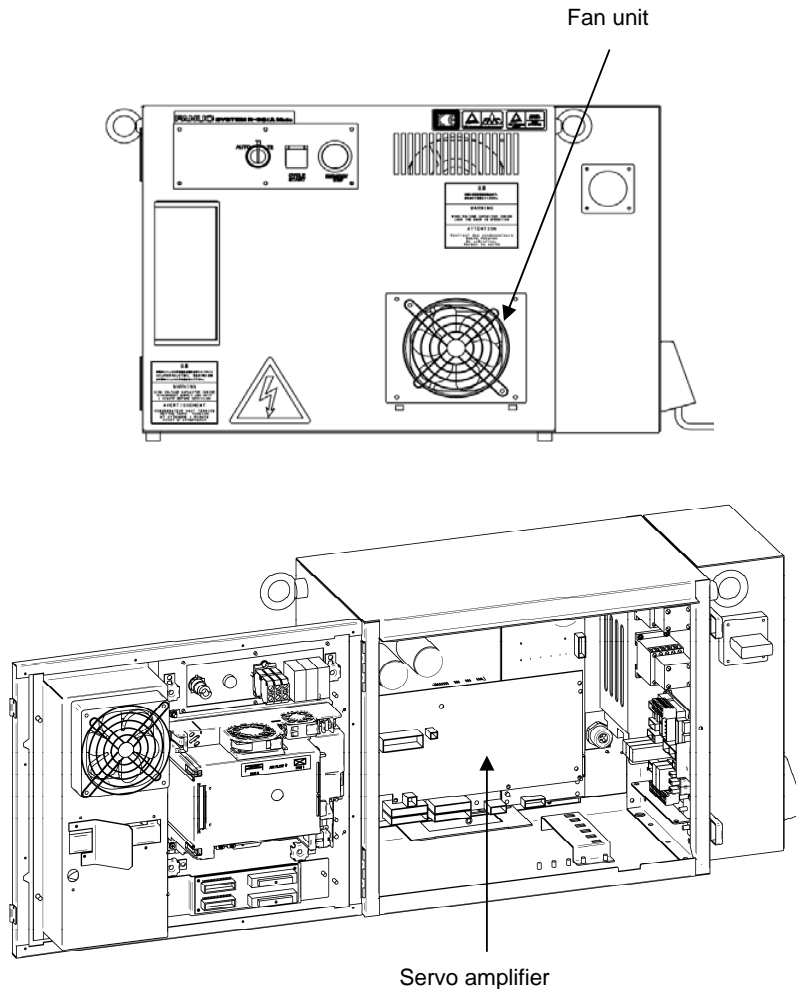


Fig.3.5 (ah) SRVO-291 IPM over heat

(87) SRVO-300 Hand broken/HBK disabled

SRVO-302 Set Hand broken to ENABLE

(Explanation) Although HBK was disabled, the HBK signal was input.

(Action 1) Press RESET on the teach pendant to release the alarm.

(Action 2) Check whether the hand broken signal is connected to the robot. When the hand broken signal circuit is connected, enable hand broken. (See Subsection 5.6.4 in Part III, "CONNECTIONS".)

(88) SRVO-335 DCS OFFCHK alarm a,b

(Explanation) A failure was detected in the safety signal input circuit.

(Action 1) Replace the E-stop board.

(Action 2) Replace the main board.

(89) SRVO-348 DCS MCC OFF alarm a,b

(Explanation) A command was issued to turn off the magnetic contactor, but the magnetic contactor was not turned off.

(Action 1) Replace the E-stop unit.

Before executing the (Action 2), perform a complete controller back-up to save all your programs and settings.

(Action 2) Replace the main board.

(90) SRVO-349 DCS MCC ON alarm a,b

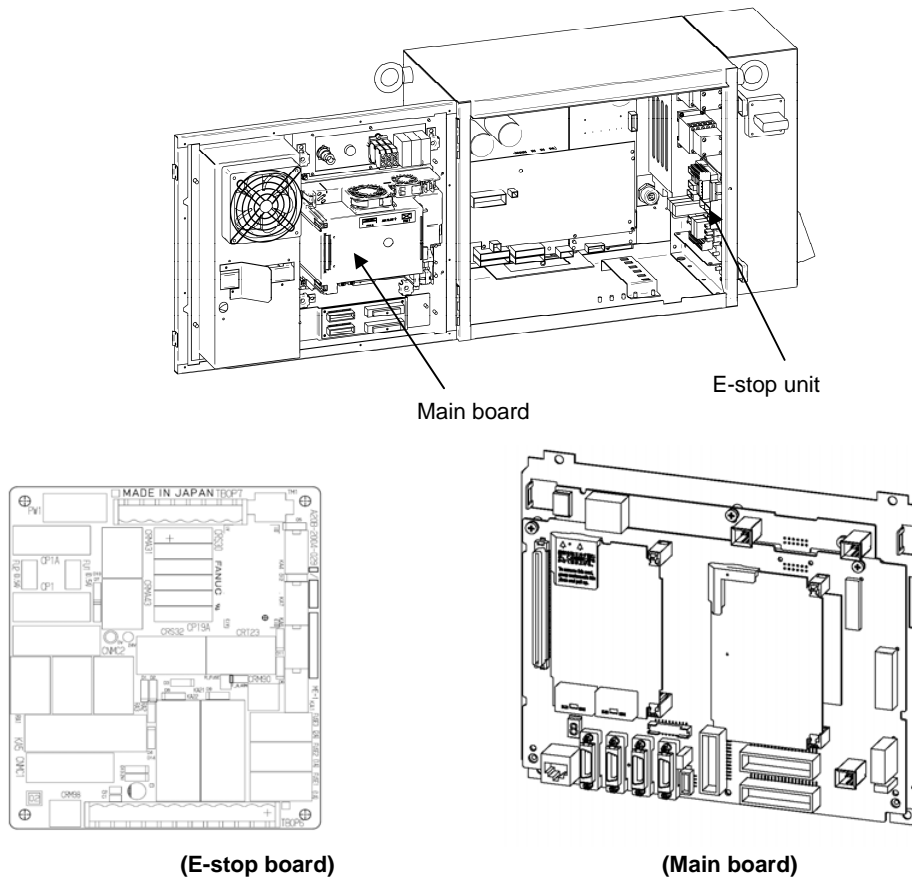
(Explanation) A command was issued to turn on the magnetic contactor, but the magnetic contactor was not turned on.

(Action 1) Replace the E-stop unit.

Before executing the (Action 2), perform a complete controller back-up to save all your programs and settings.

(Action 2) Replace the main board.

(Action 3) Replace the servo amplifier.



**Fig.3.5 (ai) SRVO-335 DCS OFFCHK alarm a,b
 SRVO-348 DCS MCC OFF alarm a,b
 SRVO-349 DCS MCC ON alarm a,b**

- (91) SRVO-370 SVON1 status abnormal a,b
SRVO-371 SVON2 status abnormal a,b

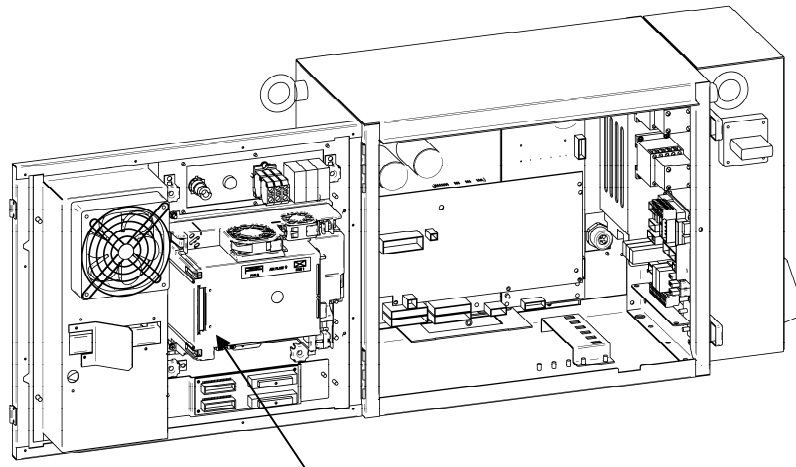
(Explanation) A chain alarm was detected with the main board internal signal (SVON).

Before executing the (Action), perform a complete controller back-up to save all your programs and settings.

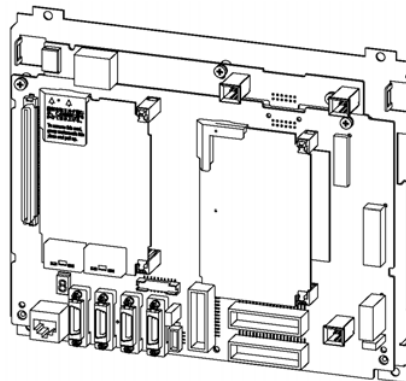
(Action) Replace the main board.

**CAUTION**

- 1 For the procedure of recovery from this alarm, see the descriptions of SRVO-230 and SRVO-231.
- 2 If this alarm is issued, do not reset the chain error alarm until the failure is checked and corrected. If robot use is continued with one of the duplicate circuits being faulty, safety may not be guaranteed when the other circuit fails.



Main board



(Main board)

Fig.3.5 (aj) SRVO-370 SVON1 status abnormal a,b
SRVO-371 SVON2 status abnormal a,b

- (92) SRVO-372 OPEMG1 status abnormal a, b
 SRVO-373 OPEMG2 status abnormal a, b

(Explanation) A chain alarm was detected with the E-stop switch on the operator's panel.

(Action 1) Check the emergency stop button connection and operation. If trouble is found, replace the emergency stop button.

(Action 2) Replace the E-stop board.

Before executing the (Action 3), perform a complete controller back-up to save all your programs and settings.

(Action 3) Replace the main board.

⚠ CAUTION

- 1 For the procedure of recovery from this alarm, see the descriptions of SRVO-230 and SRVO-231.
- 2 If this alarm is issued, do not reset the chain error alarm until the failure is checked and corrected. If robot use is continued with one of the duplicate circuits being faulty, safety may not be guaranteed when the other circuit fails.

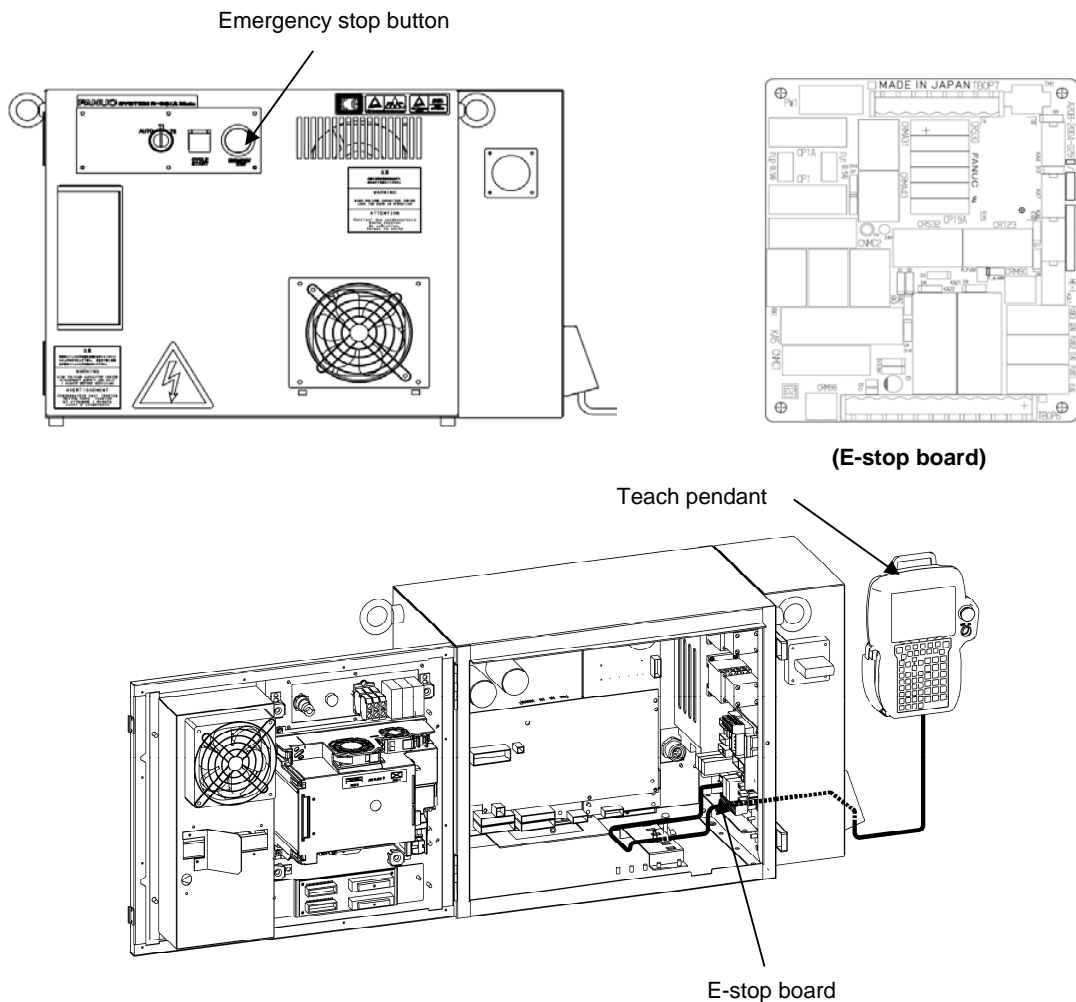


Fig.3.5 (ak) SRVO-372 OPEMG1 status abnormal a,b

- (93) SRVO-374 MODE11 status abnormal a,b
 SRVO-375 MODE12 status abnormal a,b
 SRVO-376 MODE21 status abnormal a,b
 SRVO-377 MODE22 status abnormal a,b

(Explanation) A chain alarm was detected with the mode switch signal.

(Action 1) Check the mode switch connection and operation. If trouble is found, replace the mode switch.

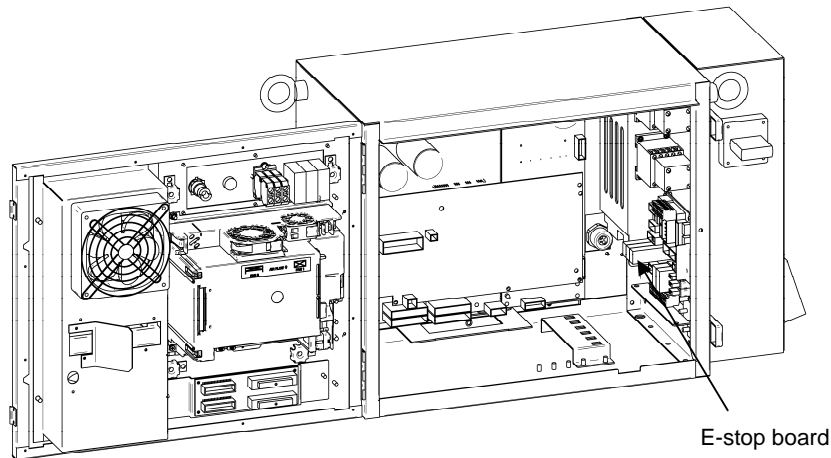
Before executing the (Action 2), perform a complete controller back-up to save all your programs and settings.

(Action 2) Replace the main board.

(Action 3) Replace the E-stop board.

⚠ CAUTION

- 1 For the procedure of recovery from this alarm, see the descriptions of SRVO-230 and SRVO-231.
- 2 If this alarm is issued, do not reset the chain error alarm until the failure is checked and corrected. If robot use is continued with one of the duplicate circuits being faulty, safety may not be guaranteed when the other circuit fails.



(E-stop board)

Fig.3.5 (a) SRVO-374 MODE11 status abnormal a,b
 SRVO-375 MODE12 status abnormal a,b
 SRVO-376 MODE21 status abnormal a,b
 SRVO-377 MODE22 status abnormal a,b

3.6 FUSE-BASED TROUBLESHOOTING

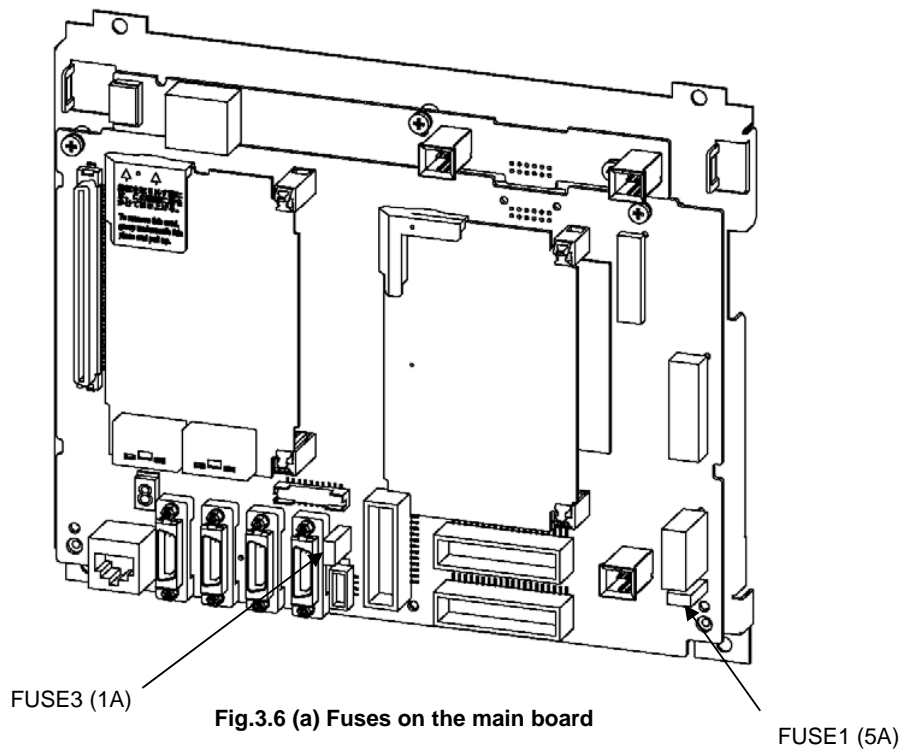
This section describes the alarms and symptoms generated and actions required when the fuses installed on the printed circuit boards and units have blown.

(1) Fuses on the main board

FUSE1: For protecting the +24V output

FUSE3: For protecting the +24V output of the peripheral device interface

Name	Symptom observed when fuse has blown	Action
FUSE1	The teach pendant becomes inoperative, and all LEDs on the main board go off.	<ol style="list-style-type: none"> 1. Replace the backplane board. 2. Replace the main board.
FUSE3	An alarm (SRVO-220) is displayed on the teach pendant.	<ol style="list-style-type: none"> 1. 24SDI and 0 V may be short-circuited. Check the peripheral device cable for any abnormality, and replace it if necessary. 2. Disconnect CRS30. If FUSE3 still blows, replace the main board. 3. Replace the cable between the emergency stop unit and the servo amplifier. 4. Replace the cable between the main board and the emergency stop unit. 5. Replace the emergency stop unit. 6. Replace the servo amplifier.



(2) Fuses on the Servo amplifier

- FS1: For generation of the power to the amplifier control circuit
- FS2: For protection of the 24V output to the end effector, ROT, and HBK
- FS3: For protection of the 24V output to the regenerative resistance and the additional axis amplifier

Name	Symptom observed when fuse has blown	Action
FS1	All LEDs on the servo amplifier go out. The FSSB disconnection or initialization alarm is displayed on the teach pendant.	Replace the servo amplifier.
FS2	The Fuse Blown (Amp) alarm (SRVO-214), Hand broken (SRVO-006), and ROBOT OVER TRAVEL are displayed on the teach pendant.	<ol style="list-style-type: none"> 1 Check +24VF used by the end effector for a ground fault. 2 Check the robot connection cable and the robot's internal cable. 3 Replace the servo amplifier.
FS3	The Fuse Blown (Amp) alarm (SRVO-214) and DCAL are displayed on the teach pendant.	<ol style="list-style-type: none"> 1 Check the regenerative resistance, and replace it if required. 2 Check the additional axis amplifier and its wiring, and replace them if required. 3 Replace the servo amplifier.

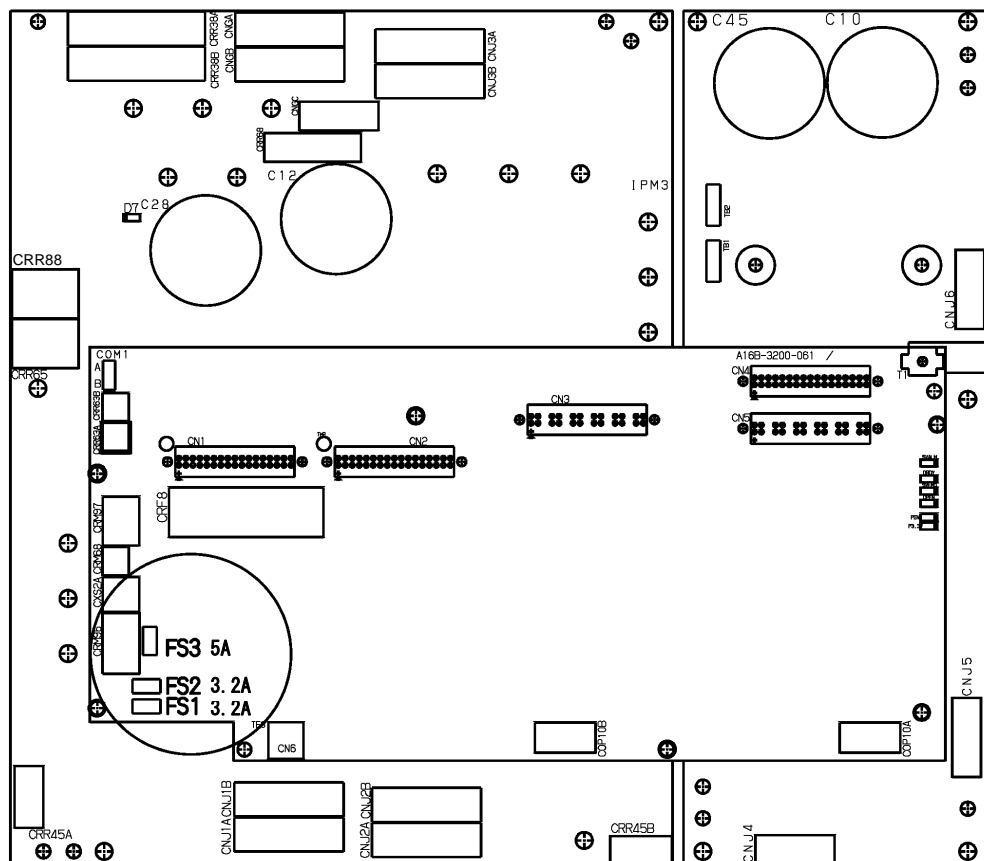


Fig.3.6 (b) Fuses on the servo amplifier

- (3) Fuses on the E-stop board
 - FUSE1: For protecting +24EXT for the emergency stop circuit
 - FUSE2: For protecting +24V for the teach pendant
 - FUSE3: For protecting +24V
 - FU1 and FU2: For protecting input for the door fan

Name	Symptom observed when fuse has blown	Action
FUSE1	Alarm (SRVO-218) is displayed on the teach pendant, and the LED (red) on the emergency stop board lights.	<ol style="list-style-type: none"> 1. If an alarm is issued when the fuse has not blown, check the voltages of EXT24V and EXT0V (TBOP6). If external 24V or 0V is not used, check the jumper pin between EXT24V and INT24V or between EXT0V and INT0V. 2. Check the +24EXT line (emergency stop line) for a short circuit or connection to ground. 3. Replace the emergency stop board.
FUSE2	The display on the teach pendant disappears, and the LED (red) on the emergency stop board lights.	<ol style="list-style-type: none"> 1. Check the teach pendant cable for any abnormality, and replace it if necessary. 2. Check the teach pendant for any abnormality, and replace it if necessary. 3. Replace the emergency stop board.
FUSE3	An alarm relating to an input signal that causes an emergency stop is issued, and the LED (red) on the emergency stop board lights.	<ol style="list-style-type: none"> 1. Check the connections on TBOP7. 2. Check the cable between the emergency stop board and the main board for any abnormality, and replace it if necessary. 3. Replace the main board. 4. Replace the emergency stop board.
FU1, FU2	The fan stops. The teach pendant cannot be operated.	<ol style="list-style-type: none"> 1. Check the fan cable for any abnormality, and replace it if necessary. 2. Replace the fan unit. 3. Replace the emergency stop board.

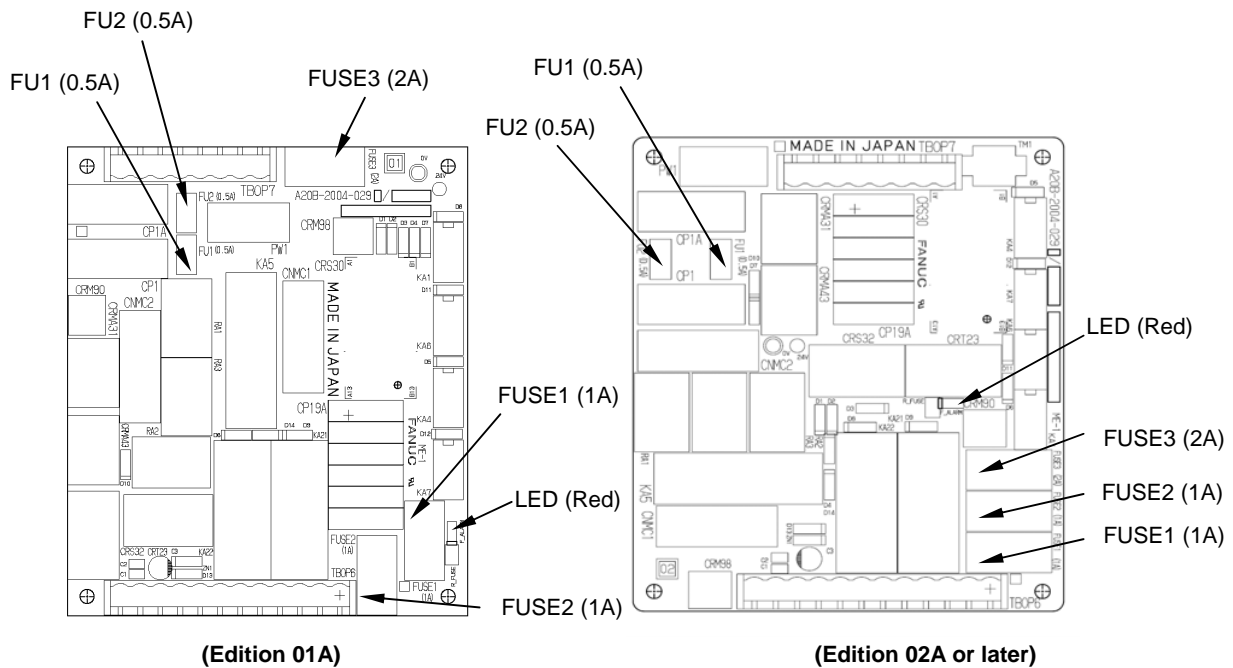


Fig.3.6 (c) Fuses on the emergency stop board

(4) Fuse FUSE1 on the process I/O board (for +24E)

Name	Symptom observed when fuse has blown	Action
FUSE1	The LED (ALM1 or FALM) the process I/O board lights.	<ol style="list-style-type: none"> 1. Check if the cables and peripheral devices connected to the process I/O board are normal. 2. Replace the process I/O board.

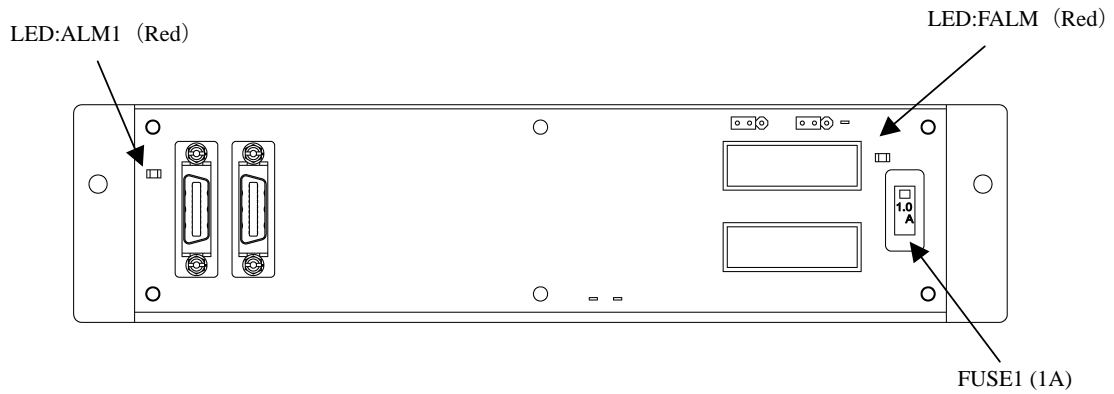


Fig.3.6 (d) Fuse on the process I/O board MA

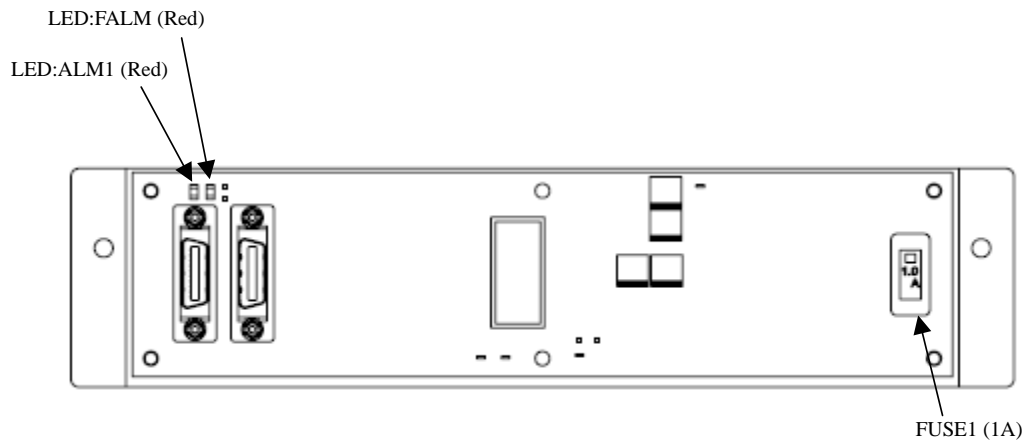


Fig.3.6 (e) Fuse on the process I/O board MB

3.7 TROUBLESHOOTING BASED ON LED INDICATIONS

The main board and servo amplifier are provided with alarm LEDs and status LEDs. The LED status and corresponding troubleshooting procedures are described below.

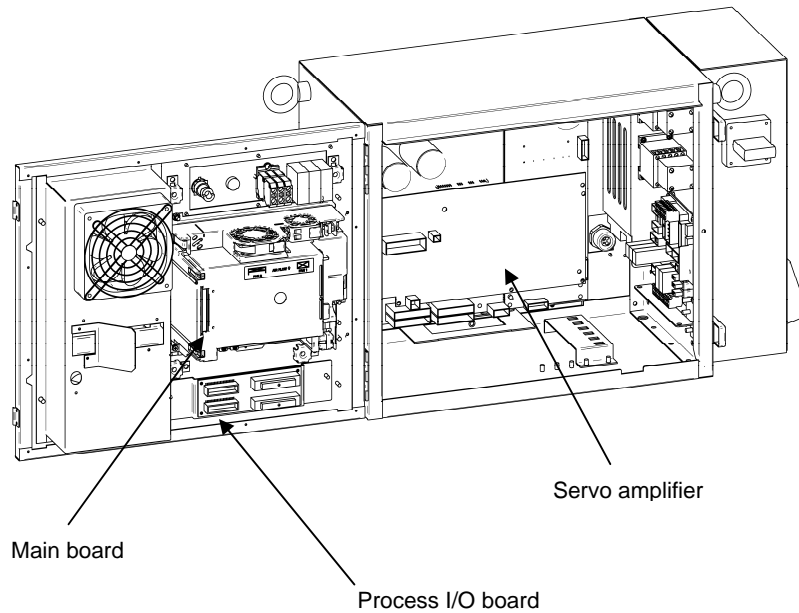


Fig.3.7 (a) Location of status LEDs

TROUBLESHOOTING USING THE LEDS ON THE MAIN BOARD

(1) Troubleshooting using the status display LED

To troubleshoot an alarm that arises before the teach pendant is ready to display, check the status LEDs (green) on the main board at power-on. After power-on, the LEDs light as described in steps 1 to end, in the order described. If an alarm is detected, the step in which the alarm occurred can be determined from which LEDs are lit.

■ : On
□ : Off
☆ : Blink

Step	LED	Action to be taken
1: After power-on, all LEDs are lit.		[Action1] Replace the CPU card. * [Action2] Replace the main board.
2: Software operation start-up.		[Action1] Replace the CPU card. * [Action2] Replace the main board.
3: The initialization of dram on the CPU card is completed.		[Action1] Replace the CPU card. * [Action2] Replace the main board.
4: The initialization of DPRAM on the communication IC is completed.		[Action1] Replace the CPU card. * [Action2] Replace the main board. * [Action3] Replace the FROM/SRAM module.
5: The initialization of the communication IC is completed.		[Action1] Replace the CPU card. * [Action2] Replace the main board. * [Action3] Replace the FROM/SRAM module.
6: The loading of the basic software is completed.		* [Action1] Replace the main board. * [Action2] Replace the FROM/SRAM module.
7: Basic software start-up.		[Action1] Check the fuse (FU1) on the emergency stop board. [Action2] Check the connection of CP1 connector on the emergency stop board. [Action3] Replace the emergency stop board. * [Action4] Replace the main board. * [Action5] Replace the FROM/SRAM module.
8: Start-up of communication with the teach pendant.		* [Action1] Replace the main board. * [Action2] Replace the FROM/SRAM module.

Step	LED	Action to be taken
9: The loading of optional software is completed.		* [Action1] Replace the main board. [Action2] Replace the process I/O board.
10: DI/DO initialization		* [Action1] Replace the FROM/SRAM module. * [Action2] Replace the main board.
11: The preparation of the SRAM module is completed.		[Action1] Replace the axis control card. * [Action2] Replace the main board. [Action3] Replace the servo amplifier.
12: Axis control card initialization		[Action1] Replace the axis control card. * [Action2] Replace the main board. [Action3] Replace the servo amplifier.
13: Calibration is completed.		[Action1] Replace the axis control card. * [Action2] Replace the main board. [Action3] Replace the servo amplifier.
14: Start-up of power application for the servo system		* [Action1] Replace the main board.
15: Program execution		* [Action1] Replace the main board. [Action2] Replace the process I/O board.
16: DI/DO output start-up.		* [Action1] Replace the main board.
17: Initialization is terminated.		Initialization has ended normally.
18: Normal status		Status LEDs 1 and 2 blink when the system is operating normally.

* If the main board or FROM/SRAM module is replaced, the contents of memory (parameters, specified data, etc.) will be lost. Before you replace the unit, therefore, make a backup copy of the data.

If an alarm is issued, data backup may be disabled. So, back up the contents of memory routinely.

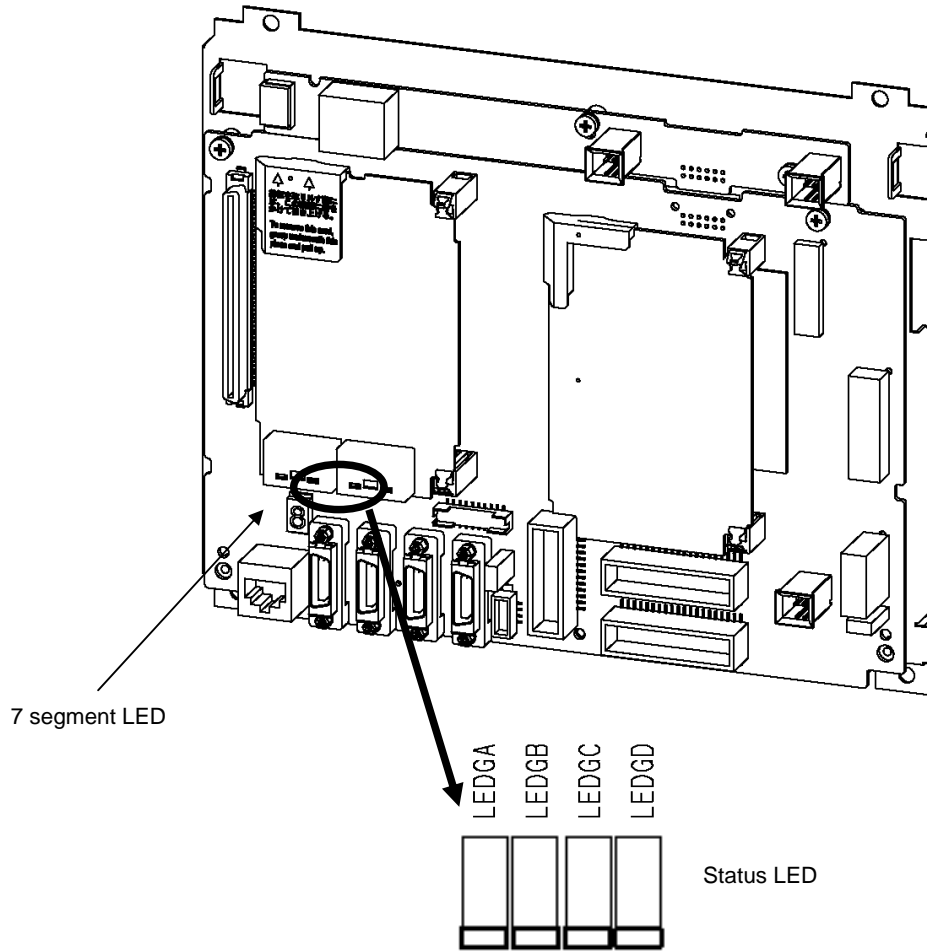










Fig.3.7 (b) LED status on the main board

(2) TROUBLESHOOTING BY 7-SEGMENT LED INDICATOR

7-segment LED indicator	Description
	[Description] A parity alarm condition has occurred in DRAM on the CPU card installed on the main board. [Action1] Replace the CPU card. * [Action2] Replace the main board.
	[Description] A parity alarm condition has occurred in SRAM on the FROM/SRAM module installed on the main board. [Action1] Replace the FROM/SRAM module. * [Action2] Replace the main board.
	[Description] A bus error has occurred in the communication controller. * [Action] Replace the main board.
	[Description] A parity alarm condition has occurred in DRAM controlled by the communication controller. * [Action] Replace the main board.
	[Description] A servo alarm condition has occurred on the main board. [Action1] Replace the axis control card. * [Action2] Replace the main board. [Action3] Replace the option board that is connected to the backplane.
	[Description] The SYSEMG alarm has occurred. [Action1] Replace the axis control card. [Action2] Replace the CPU card. * [Action3] Replace the main board.
	[Description] The SYSFAIL alarm has occurred. [Action1] Replace the axis control card. [Action2] Replace the CPU card. * [Action3] Replace the main board. [Action4] Replace the option board that is connected to the backplane.
	[Description] 5V is supplied to Main board. Above alarms do not occur.

* If the main board or FROM/SRAM module is replaced, the contents of memory (parameters, specified data, etc.) will be lost. Before you replace the unit, therefore, make a backup copy of the data.

If an alarm is issued, data backup may be disabled. So, back up the contents of memory routinely.

Troubleshooting by LEDs on servo amplifier

The servo amplifier has alarm LEDs. Troubleshoot the alarm indicated by the LEDs, referring also to the alarm indication on the teach pendant.

Check that the voltage is not higher than 50V.

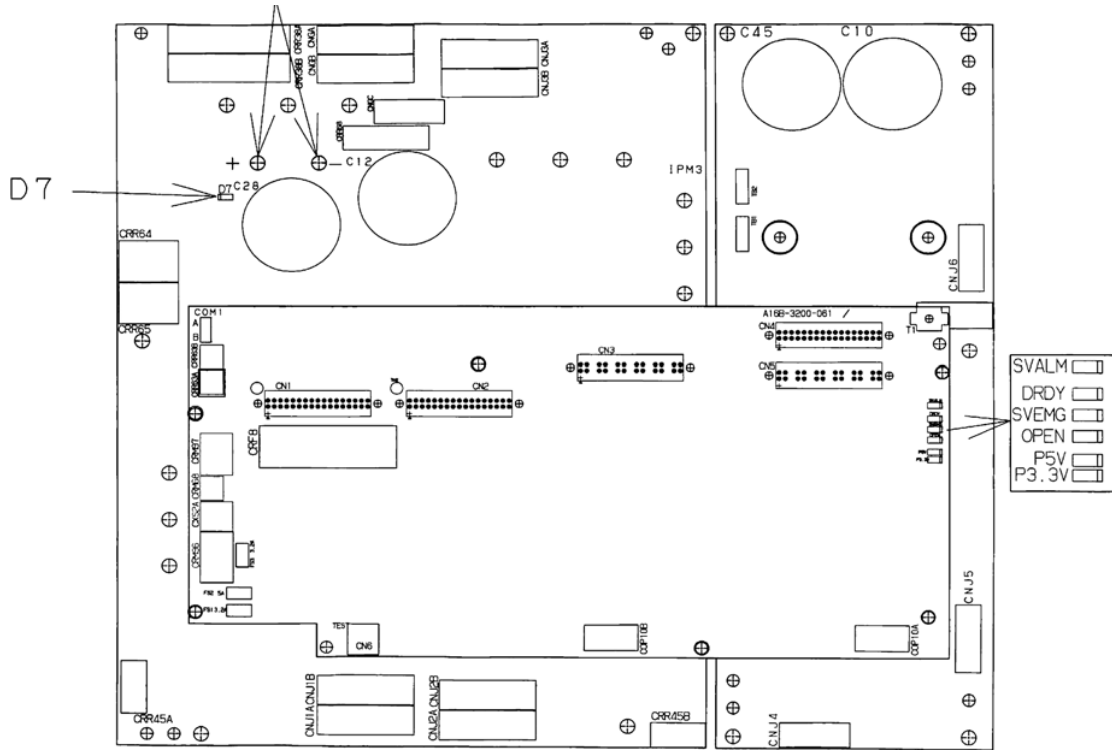


Fig.3.7 (c) LED status on the servo amplifier

⚠ CAUTION
 Before touching the servo amplifier, check the DC link voltage with the screws located above the LED "D7". By using a DC voltage tester, check that the voltage is 50 V or less.

LED	Color	Description
P5V	Green	Lights when the power supply circuit inside the servo amplifier outputs a voltage of +5 V normally. <u>If the LED does not light:</u> [Measure 1] Check the robot connection cable (RMP) to see if there is a ground fault in the +5V wire. [Measure 2] Replace the servo amplifier.
P3.3V	Green	Lights when the power supply circuit inside the servo amplifier outputs a voltage of +3.3 V normally. <u>If the LED does not light:</u> [Measure] Replace the servo amplifier.
SVEMG	Red	Lights when an emergency stop signal is input to the servo amplifier. <u>If the LED lights when the machine is not at an emergency stop:</u> [Measure] Replace the servo amplifier. <u>If the LED does light when the machine is at an emergency stop:</u> [Measure] Replace the servo amplifier.

LED	Color	Description
ALM	Red	Lights when the servo amplifier detects an alarm. <u>If the LED lights when there is no alarm condition in the machine:</u> [Measure] Replace the servo amplifier. <u>If the LED does not light when there is an alarm condition in the machine:</u> [Measure] Replace the servo amplifier.
DRDY	Green	Lights when the servo amplifier is ready to drive the servo motor. <u>If the LED does not light when the motor is activated:</u> [Measure] Replace the servo amplifier.
OPEN	Green	Lights when the communication between the servo amplifier and the main board is normal. <u>If the LED does not light:</u> [Measure 1] Check for the connection of the FSSB optical cable. [Measure 2] Replace the servo card. [Measure 3] Replace the servo amplifier.
D7	Red	Lights when the DCLINK circuit inside the servo amplifier is charged to reach the specified voltage. <u>If the LED does not light after pre-charge is finished:</u> [Measure 1] It is likely that the DC Link may be short-circuited. Check for connection. [Measure 2] It is likely that the charge current control resistor may be defective. Replace the emergency stop unit. [Measure 3] Replace the servo amplifier.

Troubleshooting by LEDs on Process I/O board

LED	Color	Description
ALM1	Red	[Explanation] An alarm was issued during communication between the main board and the process I/O board. [Measure 1] Replace the process I/O board. [Measure 2] Replace the I/O link connection cable. [Measure 3] Replace the main board.
FALM	Red	[Explanation] The fuse on the process I/O board was blown. [Measure 1] Replace the fuse on the process I/O board. [Measure 2] Check the cables and peripheral units connected to the process I/O board and replace the defective units. [Measure 3] Replace the process I/O board.

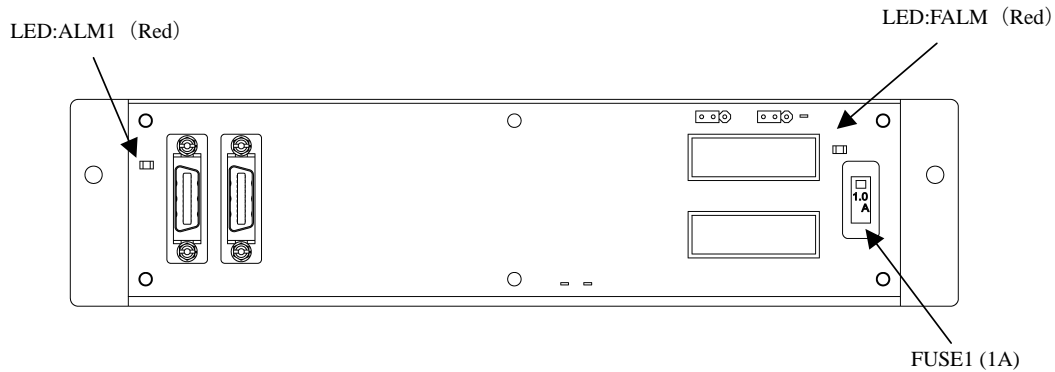


Fig.3.7 (d) LED status on the process I/O board MA

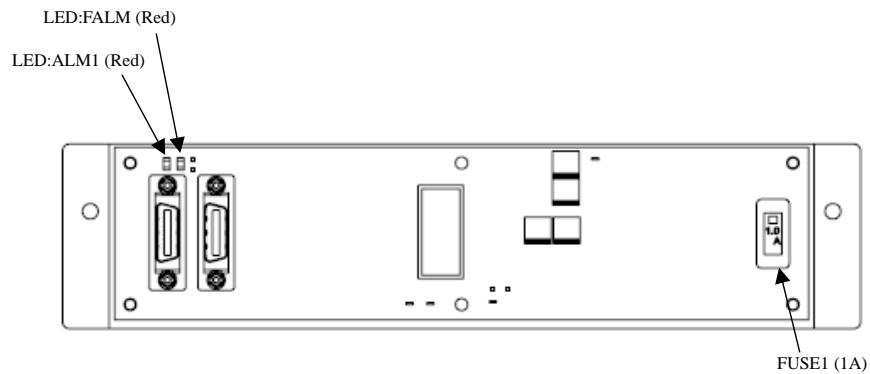


Fig.3.7 (e) Fuse on the process I/O board MB

3.8 CHECK AND REPLACEMENT SURGE ABSORBER

The surge absorber is mounted at primary power supply of controller.
It is necessary to check the surge absorber as following procedure.

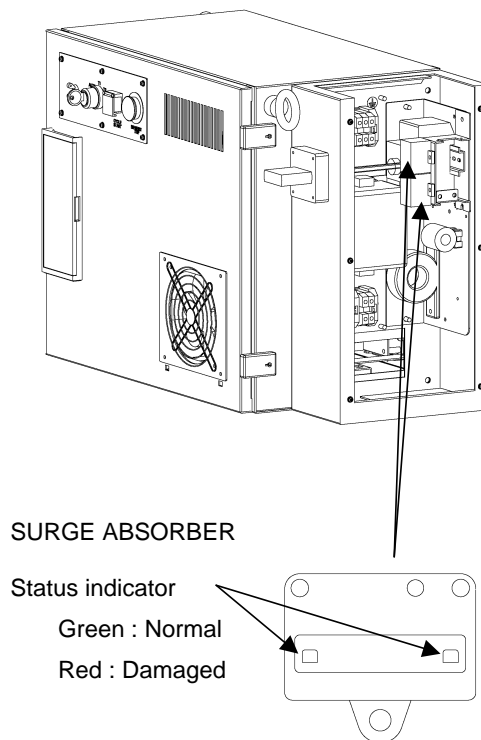


Fig.3.8 Status indicator of the surge absorber

The surge absorber has the status indicator. Check the status indicator every six months. In addition, if surge absorber has been damaged, replace the surge absorber.

⚠ CAUTION

In case of lightning surge attack, the performance of surge absorber may be possibility of damage. In this case, check the status indicator of surge absorber. In addition, if surge absorber has been damaged, replace the surge absorber.

3.9 POSITION DEVIATION FOUND IN RETURN TO THE REFERENCE POSITION (POSITIONING)

- (Check 1) On the status screen, check the position deviation in the stopped state. To display the position deviation, press the screen selection key, and select STATUS from the menu. Press F1, [TYPE], select AXIS from the menu, then press the F4, PULSE.
(Corrective action)
Correct the parameters related to return to the reference position (positioning).
- (Check 2) Check whether the motor axis can be positioned normally.
(Corrective action)
If the motor axis can be positioned normally, check the mechanical unit.
- (Check 3) Check the mechanical unit for backlash.
(Corrective action)
Replace a faulty key of motor shaft or other faulty parts.
- (Check 4) If checks 1 to 3 show normal results
(Corrective action)
Replace the Pulsecoder and main board.

* If the main board or FROM/SRAM module is replaced, the contents of memory (parameters, specified data, etc.) will be lost. Before you replace the unit, therefore, make a backup copy of the data.

3.10 MANUAL OPERATION IMPOSSIBLE

The following explains checking and corrective action required if the robot cannot be operated manually after the controller is turned on:

- (1) Check and corrective action to be made if manual operation is impossible
- (Check 1) Check whether the teach pendant is enabled.
(Corrective action)
Turn on the teach pendant "enable".
- (Check 2) Check whether the teach pendant is handled correctly.
(Corrective action)
To move an axis by manual operation, press the axis selection key and shift key at the same time.
Set the override for manual feed to a position other than the FINE and VFINE positions.
- (Check 3) Check whether the ENBL signal of the peripheral device control interface is on.
(Corrective action)
Place the peripheral device control interface in the ENBL status.
- (Check 4) Check whether the HOLD signal of the peripheral device control interface (hold status). (Check whether the hold lamp on the teach pendant is on.)
(Corrective action)
Turn off the HOLD signal of the peripheral device control interface.
- (Check 5) Check whether the previous manual operation has been completed.
(Corrective action)
If the robot cannot be placed in the effective area because of the offset of the speed command voltage preventing the previous operation from being completed, check the position deviation on the status screen, and change the setting.
- (Check 6) Check whether the controller is in the alarm status.
(Corrective action)
Release the alarm.

- (2) Check and corrective action to be taken if the program cannot be executed
- (Check 1) Check whether the ENBL signal for the peripheral-device control interface is on.
(Corrective action)
Put the peripheral-device control interface in the ENBL state.
 - (Check 2) Check whether the HOLD signal for the peripheral-device control interface is on.
Also check whether the HOLD lamp on the teach pendant is on.
(Corrective action)
If the HOLD signal of the peripheral device control interface is on, turn it off.
 - (Check 3) Check whether the previous manual operation has been completed.
(Corrective action)
If the robot cannot be placed in the effective area because of the offset of the speed command voltage, which prevents the previous operation from being completed, check the position deviation on the status screen, then change the setting.
 - (Check 4) Check whether the controller is in the alarm status.
(Corrective action)
Release the alarm.

4 PRINTED CIRCUIT BOARDS

The printed circuit boards are factory-set for operation. Usually, you do not need to set or adjust them. This chapter describes the standard settings and adjustment required if a defective printed circuit board is replaced. It also describes the test pins and the LED indications.

The control unit printed circuit board includes the main unit printed circuit board and one or more cards or modules installed horizontally to the main-unit printed-circuit board.

These PC boards have interface connectors, LED indicators, and a plastic panel at the front. At the rear, there is a backplane connector.

4.1 MAIN BOARD (A20B-8200-0470)

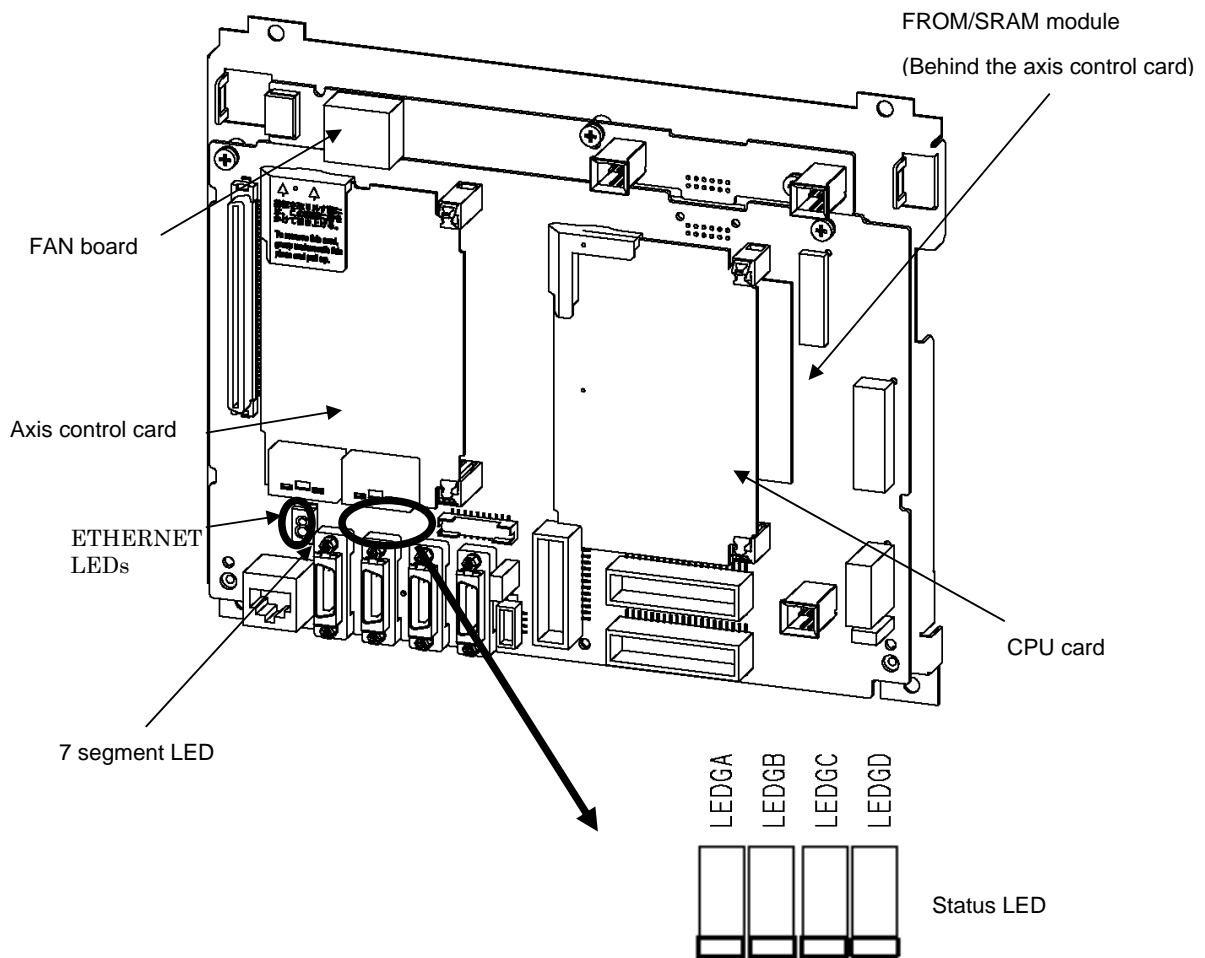



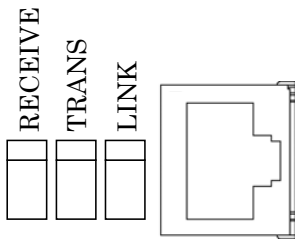
Fig.4.1 Main board

Name	Ordering Specification	Board Specification	Note
Main board	A05B-2550-H001	A20B-8200-0470	Standard
	A05B-2550-H002	A20B-8200-0471	Vision
	A05B-2550-H003	A20B-8200-0472	Vision, Force sensor
CPU card	A05B-2550-H020	A20B-3400-0020	DRAM 32M
	A05B-2550-H021	A20B-3400-0021	DRAM 64M
Axis control card	A05B-2550-H040	A20B-3300-0448	8-axis
	A05B-2550-H041	A20B-3300-0447	12-axis
	A05B-2550-H042	A20B-3300-0442	16-axis
FROM/SRAM module	A05B-2550-H060	A20B-3900-0223	FROM 32M/ SRAM 1M
	A05B-2550-H061	A20B-3900-0224	FROM 32M/ SRAM 2M
	A05B-2550-H062	A20B-3900-0225	FROM 32M/ SRAM 3M
	A05B-2550-H063	A20B-3900-0226	FROM 64M/ SRAM 1M
	A05B-2550-H064	A20B-3900-0227	FROM 64M/ SRAM 2M
	A05B-2550-H065	A20B-3900-0228	FROM 64M/ SRAM 3M
FAN board	A05B-2550-H001	A20B-8002-0639	
	A05B-2550-H002		

(1) LEDs

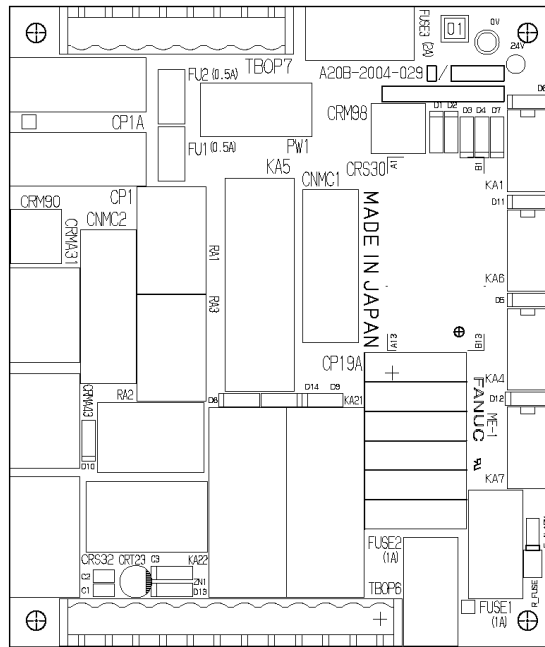
Seven segment LED	Description
	A parity alarm occurred in a DRAM of the CPU card on the main board.
	A parity alarm occurred in a SRAM of the FROM/SRAM module on the main board.
	Bus error occurred on the communication controller.
	A parity alarm occurred in DRAM controlled by communication controller.
	A servo alarm occurred on the main board.
	SYSEMG occurred.
	SYSFAIL occurred.
	5V is supplied to Main board. Above 0-7 alarms do not occur.

Status LED	Description
<div style="text-align: center;"> <p>LEDGA LEDGB LEDGC LEDGD</p>  </div>	<p>Operating status of the system.</p>

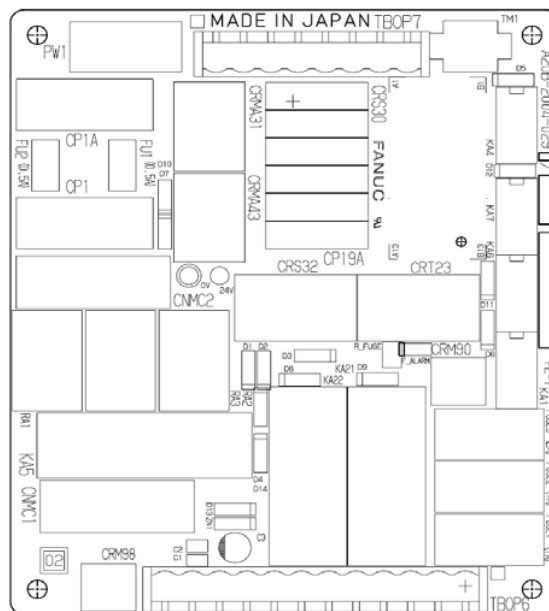


ETHERNET LED	Color	Description
RECEIVE	Green	Blinks when data is received.
TRANS	Green	Flashes during data transmission.
LINK	Green	Lights when a link is established.

4.2 EMERGENCY STOP CONTROL BOARD (A20B-2004-0290)



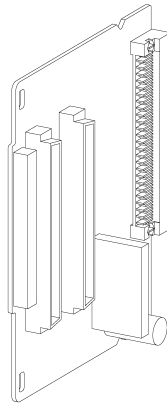
(Edition 01A)



(Edition 02B or later)

Fig.4.2 Emergency stop control board

4.3 BACKPLANE BOARD (A20B-8101-0580)



(Backplane board)

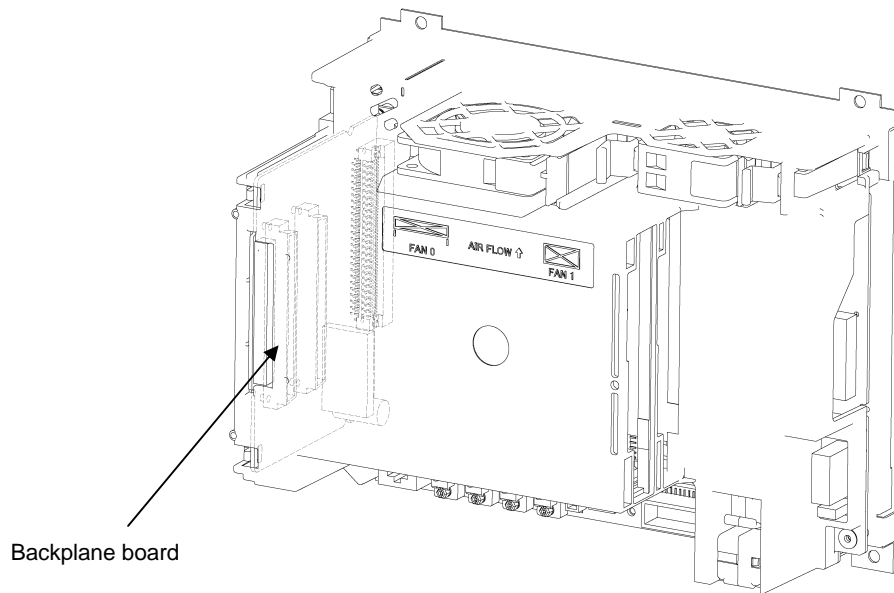


Fig.4.3 Backplane board

4.4 PROCESS I/O BOARD MA (A20B-2004-0380)

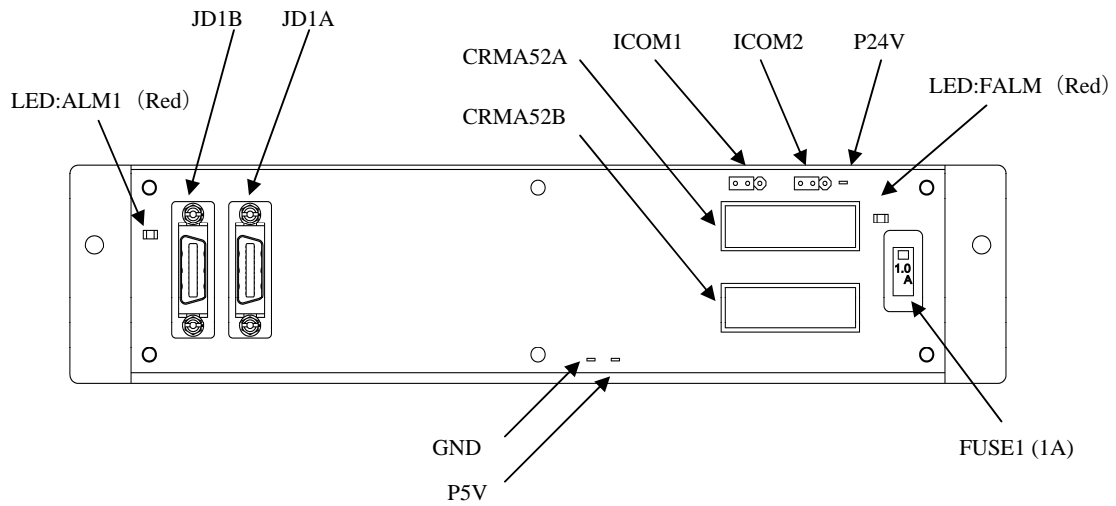


Fig.4.4 Process I/O board MA

(1) Test pins

Name		Use
P24V	+24V	For measuring the DC supply voltage
P5V	+5V	
GND	GND	

(2) Settings

Name		Standard setting	Description
ICOM1	UDI1- 10 (Connector CRMA52A)	Side A	For common voltage setting Side A: +24V common Side B: 0V common
ICOM2	UDI11- 20 (Connector CRMA52B)		

(3) LEDs

Name	Color	Description
ALM1	Red	A communication alarm occurred between the main CPU and process I/O board.
FALM	Red	The fuse (FUSE1) on the process I/O board has blown.

4.5 PROCESS I/O BOARD MB (A20B-2101-0730)

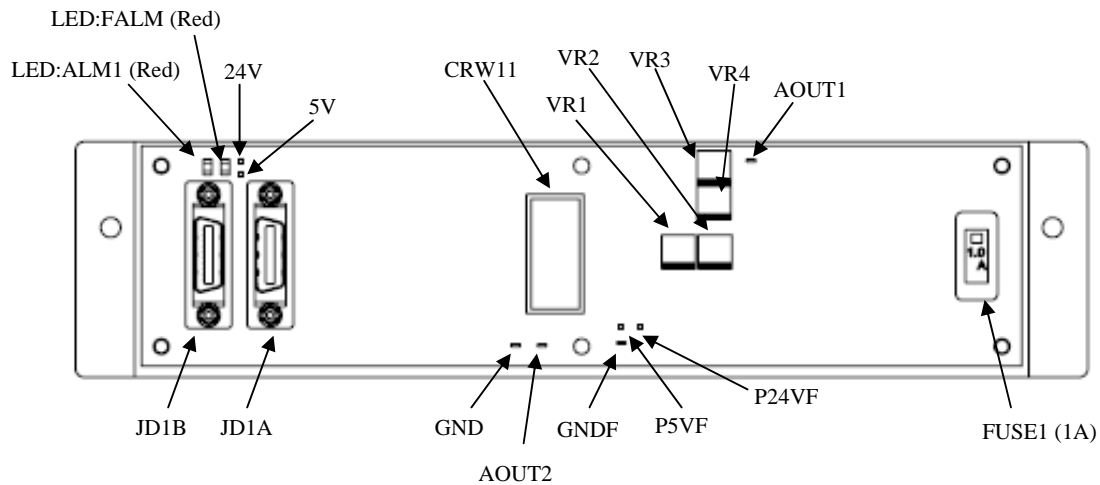


Fig.4.5 Process I/O board MB

(1) Test pins and pads

Name		Use
24V	+24V	For measuring the DC supply voltage
5V	+5V	
GND	GND	
P24VF	+24V	D/A converter power supply
P5VF	+5V	
GNDF	GND	
AOUT1	Channel 1	For analog output signal (D/A) voltage measurement
AOUT2	Channel 2	

(2) Adjustment

VR1/VR2 Channel 1 gain and offset adjustment

Connect the “+” and “-” terminals of a digital voltmeter, respectively, to the AOUT1 check pin and the GNDF check pin (not a general ground point). From the teach pendant, execute AOUT[1]=3413, using a robot program. While observing the voltage at the AOUT1 check pin with the digital voltmeter, adjust potentiometers VR1 and VR2 for 15.0V.

VR3/VR4 Channel 2 gain and offset adjustment

Connect the “+” and “-” terminals of a digital voltmeter, respectively, to the AOUT2 check pin and the GNDF check pin (not a general ground point). From the teach pendant, execute AOUT[2]=3413, using a robot program. While observing the voltage at the AOUT2 check pin with the digital voltmeter, adjust potentiometers VR3 and VR4 for 15.0V.

(3) LEDs

Name	Color	Description
ALM1	Red	A communication alarm occurred between the main CPU and process I/O board.
FALM	Red	The fuse (FUSE1) on the process I/O board has blown.

4.6 CONNECTOR CONVERTER BOARD (A20B-2004-0410)

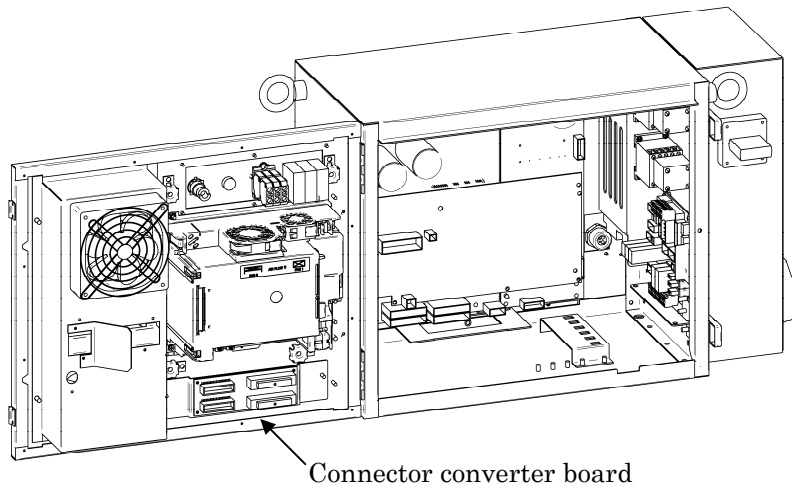
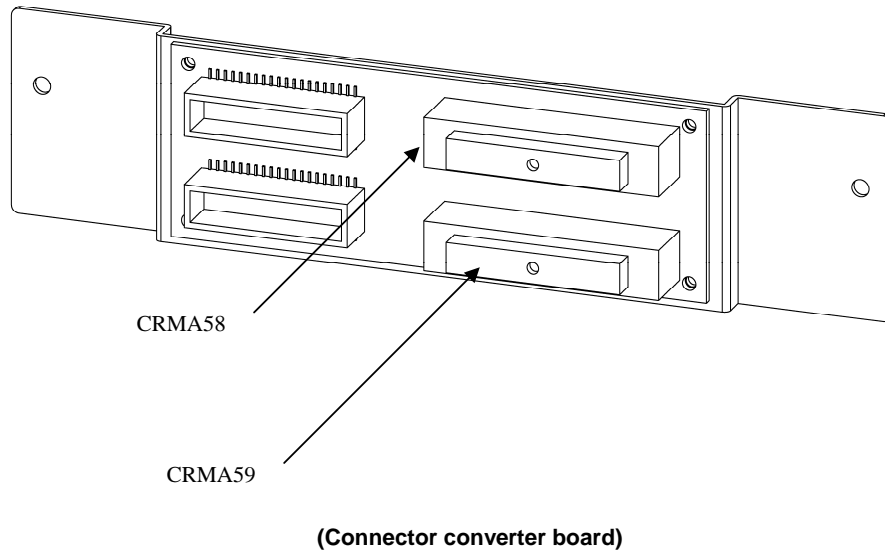


Fig.4.6 Location of the Connector converter board

5 SERVO AMPLIFIERS

The servo amplifiers are factory-set for operation. Usually, you do not need to set or adjust them. This chapter describes the standard settings and adjustment required if a defective servo amplifier is replaced. It also describes the use of test pins and meanings of the LED indications.

Table 5 Servo amplifier specifications

Robot	Servo amplifier	Regenerative resistor
LR Mate 200iC	A06B-6107-H005	A05B-2550-C050
M-1iA	A06B-6107-H005	A05B-2550-C050
ARC Mate 100iC, M-10iA, ARC Mate 0iA	A06B-6107-H004	A05B-2550-C051
ARC Mate 100iCe, M-10iAe	A06B-6107-H004	A05B-2550-C053
ARC Mate 120iC, M-20iA	A06B-6107-H002	A05B-2550-C052
ARC Mate 50iC	A06B-6107-H005	A05B-2550-C051

Check that the voltage is not higher than 50V.

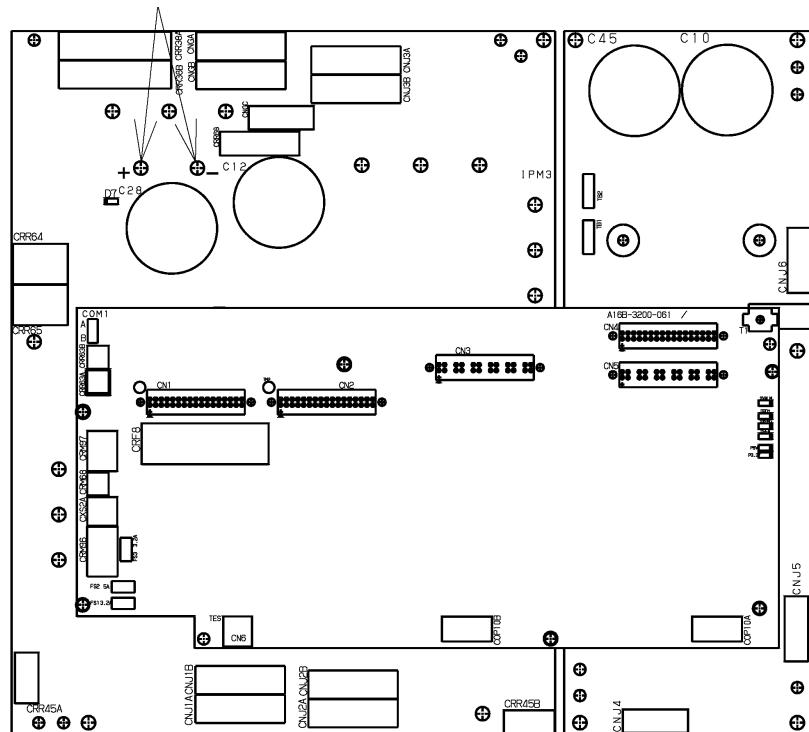


Fig.5 Servo amplifier

⚠ WARNING

Before touching the servo amplifier, check the DC link voltage with the screws located above the LED "D7". By using a DC voltage tester, check that the voltage is 50 V or less.

5.1 LED OF SERVO AMPLIFIER

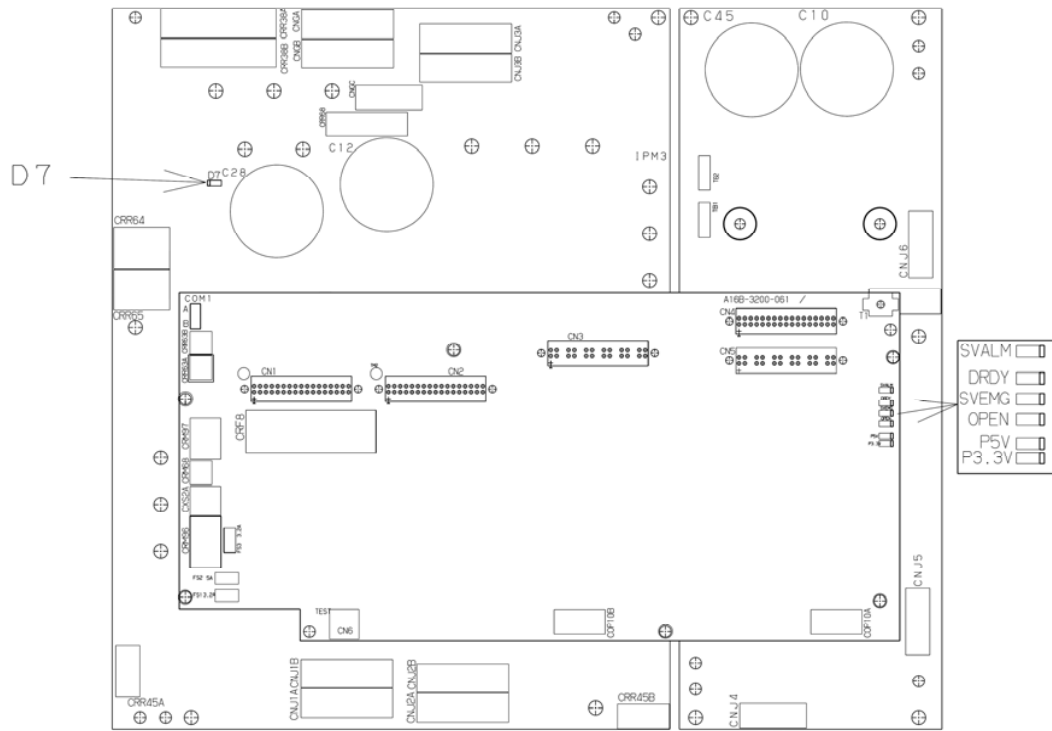


Fig.5.1 LED of servo amplifier

LED	Color	Description
P5V	Green	Lights when the power supply circuit inside the servo amplifier outputs a voltage of +5 V normally.
P3.3V	Green	Lights when the power supply circuit inside the servo amplifier outputs a voltage of +3.3 V normally.
SVEMG	Red	Lights when an emergency stop signal is input to the servo amplifier.
SVALM	Red	Lights when the servo amplifier detects an alarm.
DRDY	Green	Lights when the servo amplifier is ready to drive the servo motor.
OPEN	Green	Lights when the communication between the servo amplifier and the main board is normal.
D7	Red	Lights when the DCLINK circuit inside the servo amplifier is charged to reach a specific voltage.

5.2 SETTING OF SERVO AMPLIFIER

Table 5.2 Settings

Name	Standard setting	Description
COM1	Side A	Robot Digital Input (RI) device common voltage. Side A: +24V common Side B: 0V common

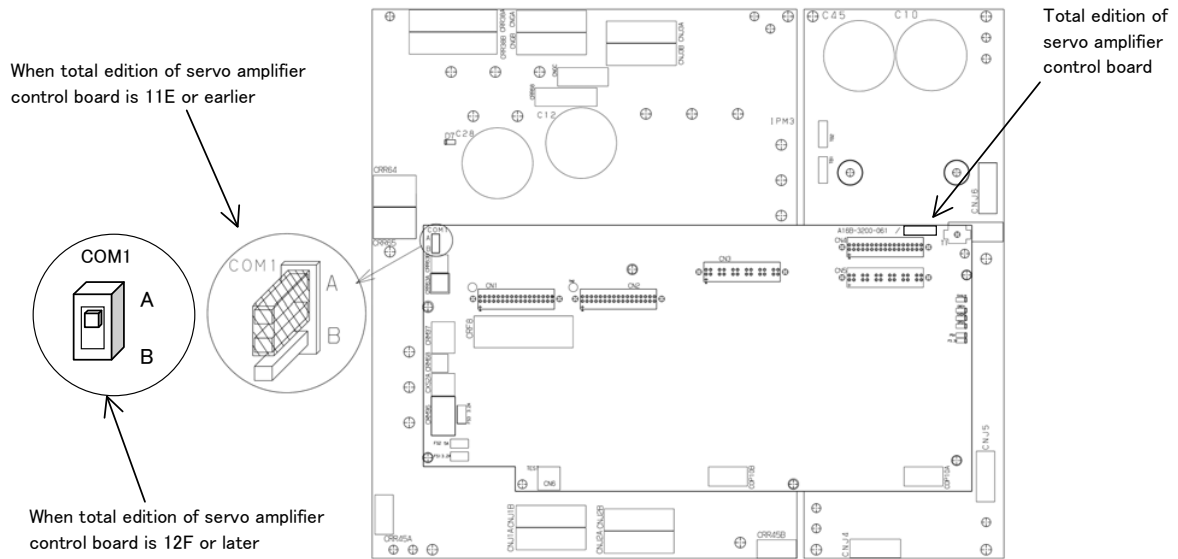


Fig.5.2 (a) Setting of servo amplifier

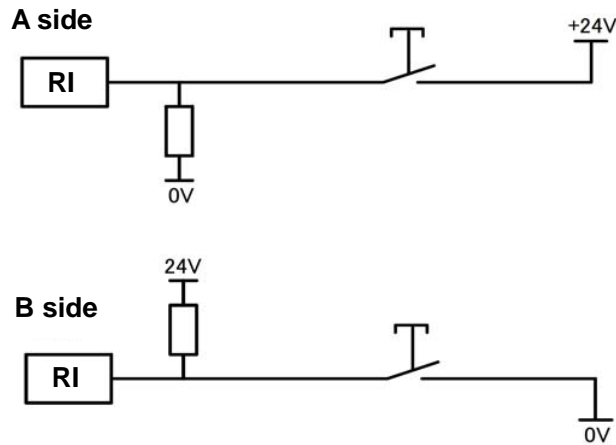


Fig.5.2 (b) Circuit based on jumper pin location or setting of switch

6 SETTING THE POWER SUPPLY

Setting and adjustment of the power supply is factory-set for operation. Usually, you do not need to set or adjust it.

6.1 BLOCK DIAGRAM OF THE POWER SUPPLY

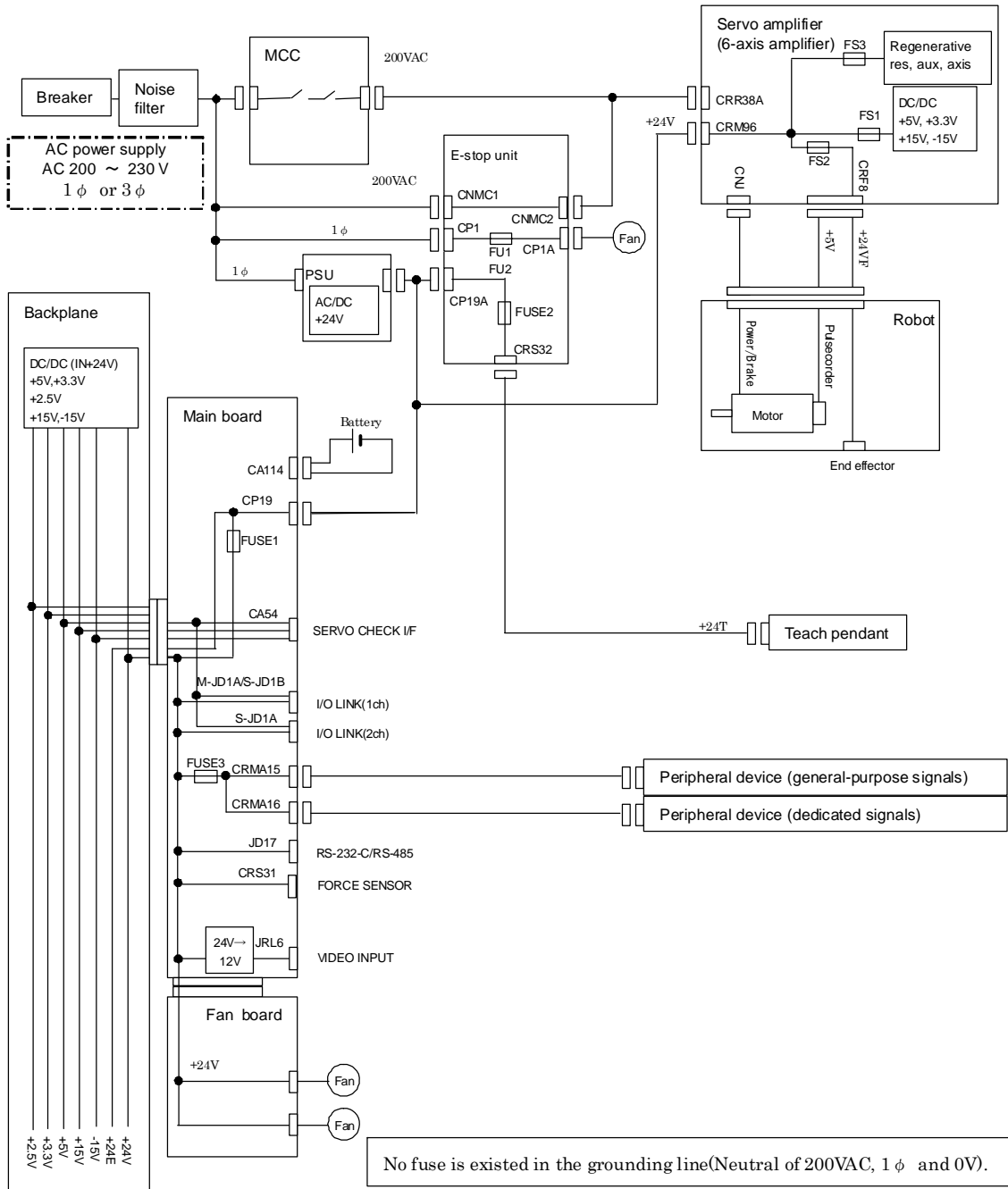


Fig.6.1 Block diagram of the power supply

6.2 CHECKING THE POWER SUPPLY

The power supply need not be set or adjusted.

Table 6.2 Rating of the power supply

Output	Rated voltage	Tolerance
+5V	+5.1V	±3%
+3.3V	+3.3V	±3%
+2.5V	+2.5V	±3%
+24V	+24V	±5%
+24E	+24V	±5%
+15V	+15V	±10%
-15V	-15V	±10%

7 REPLACING A UNIT

This section explains how to replace each unit in the control section.

WARNING

- 1 Before you start to replace a unit, turn off the control unit main power. Also, keep all machines in the area of the control unit switched. Otherwise, you could injure personnel or damage equipment.
- 2 Before replacing components, read the maintenance manual to understand the replacement procedure. Performing an incorrect replacement procedure can lead to an unpredictable accident, resulting in breakage in the robot or personal injury.
- 3 When a heavy component or unit is to be handled, support the workers with a crane or the like not to apply excessive loads to the workers. Note that incorrect handling can cause serious injury to the workers.

CAUTION

Components in the control unit heat up, so care should be taken. When you have to touch a heated component, prepare a protector such as heat-resistant gloves.

7.1 REPLACING THE PRINTED-CIRCUIT BOARDS

CAUTION

When you replace printed-circuit boards, observe the following cautions:

- 1 Keep the controller power switched off.
- 2 When you remove a printed-circuit board, do not touch the semiconductor devices on the board with your hand or make them touch other components.
- 3 Make sure that the replacement printed-circuit board has been set up appropriately. (Setting plug etc.)
- 4 After replacing a printed-circuit board, make adjustments correctly if the board needs to be adjusted.
- 5 If the backplane board, power supply unit, or main board (including cards and modules) is replaced, it is likely that robot parameters and taught data are lost. Before you start to replace these components, save a backup copy of the robot parameters and taught data to an external memory device.
- 6 Before you disconnect a cable, note its location. If a cable is detached for replacement, reconnect it exactly as before.

7.1.1 Replacing the Backplane Board (Unit)

Replace the backplane board together with the plastic case.

- (1) Remove the two screws fastening the case. (When cables are connected to option boards, detach the cables.)
- (2) Release the latches in the upper part on each side of the case from the base metal plate, and pull out the case. The case can be pulled out with the backplane board, fan, and battery installed in the case.

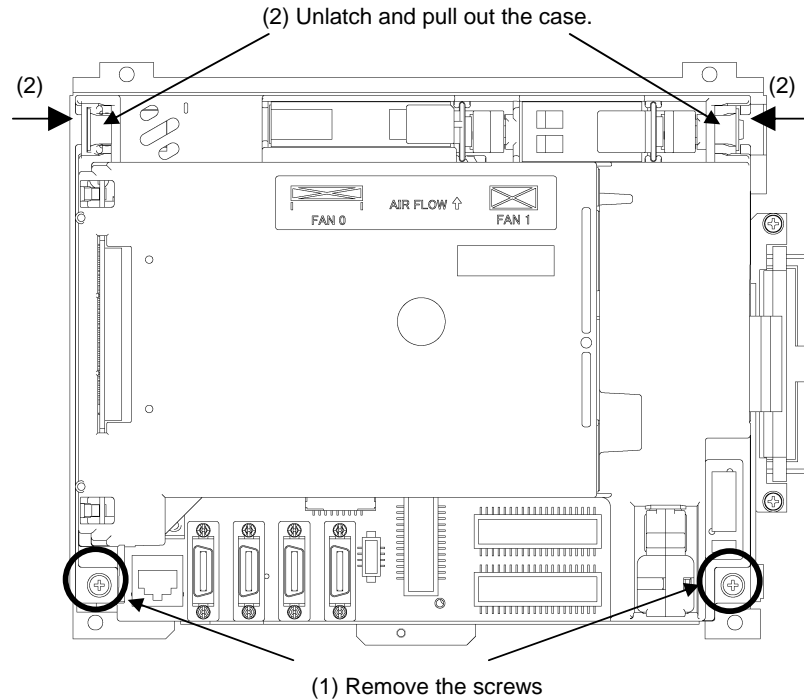


Fig.7.1.1 Replacing the backplane board

- (3) Replace the backplane unit with a new one.
- (4) Confirm that the screw and latch positions of the case are in place, and slowly set the case. When the case is attached, the backplane board installed in the case is connected to the main board with the connectors. When setting the case, check that the connectors are connected properly, and be careful not to apply excessive force.
- (5) After confirming that the case is surely latched, tighten the screws of the case. Lightly press the fan and battery, and make sure that the connectors are connected securely. (If the cables of option boards have been detached, connect the cables again.)



CAUTION

Be sure to back up all programs and a possibility of data loss when a backplane-mounted printed circuit board is replaced.

7.1.2 Replacing the Main board

The backplane unit incorporates the backplane board, main board, and option boards.



CAUTION

Before starting replacement, turn off the main power of the controller. The main board is equipped with battery-backed memory devices for holding robot parameters and taught data. When the main board is replaced, the memory contents are lost.

- (1) Remove the case. (See Subsection 7.1.1.)
- (2) Detach cables from the connectors on the main board, and remove the three screws fastening the main board. The main board and fan board are connected directly with connector CA115A. Detach the main board by sliding the main board downward.

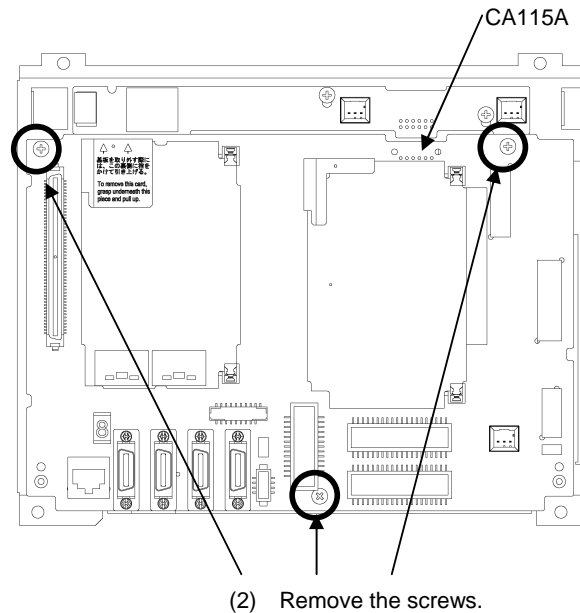


Fig.7.1.2 Replacing the main board

- (3) Replace the main board with a new one.
- (4) Install the case. (See Subsection 7.1.1.)

7.2 REPLACING CARDS AND MODULES ON THE MAIN BOARD



CAUTION

Before you start to replace a card or module, make a backup copy of robot parameters and taught data. If the FROM/SRAM module is replaced, SRAM memory contents are lost.

Demounting a Card

- (1) Pull up the spacer metal fitting.
- (2) A molded cover is attached to a corner of the servo card and CPU card although the shapes of the covers attached to the cards differ from each other. Insert a finger into the rear of the cover and pull up the cover slowly in the arrow direction shown in the figure below. (Note: At this time, hold the neighborhood of the main board on the opposite side with the other hand whenever possible. A force of 7 to 8 kgf is required for extraction. Be careful not to drop the card board due to the momentum of extraction.)
- (3) When one side of the card board is raised slightly by pulling up the cover, do not fully extract the card board, but push back the cover softly.
- (4) When the card board is pushed back to be parallel with the main board, pinch two sides of the card board and pull up the card board. This completes the extraction of the card board.

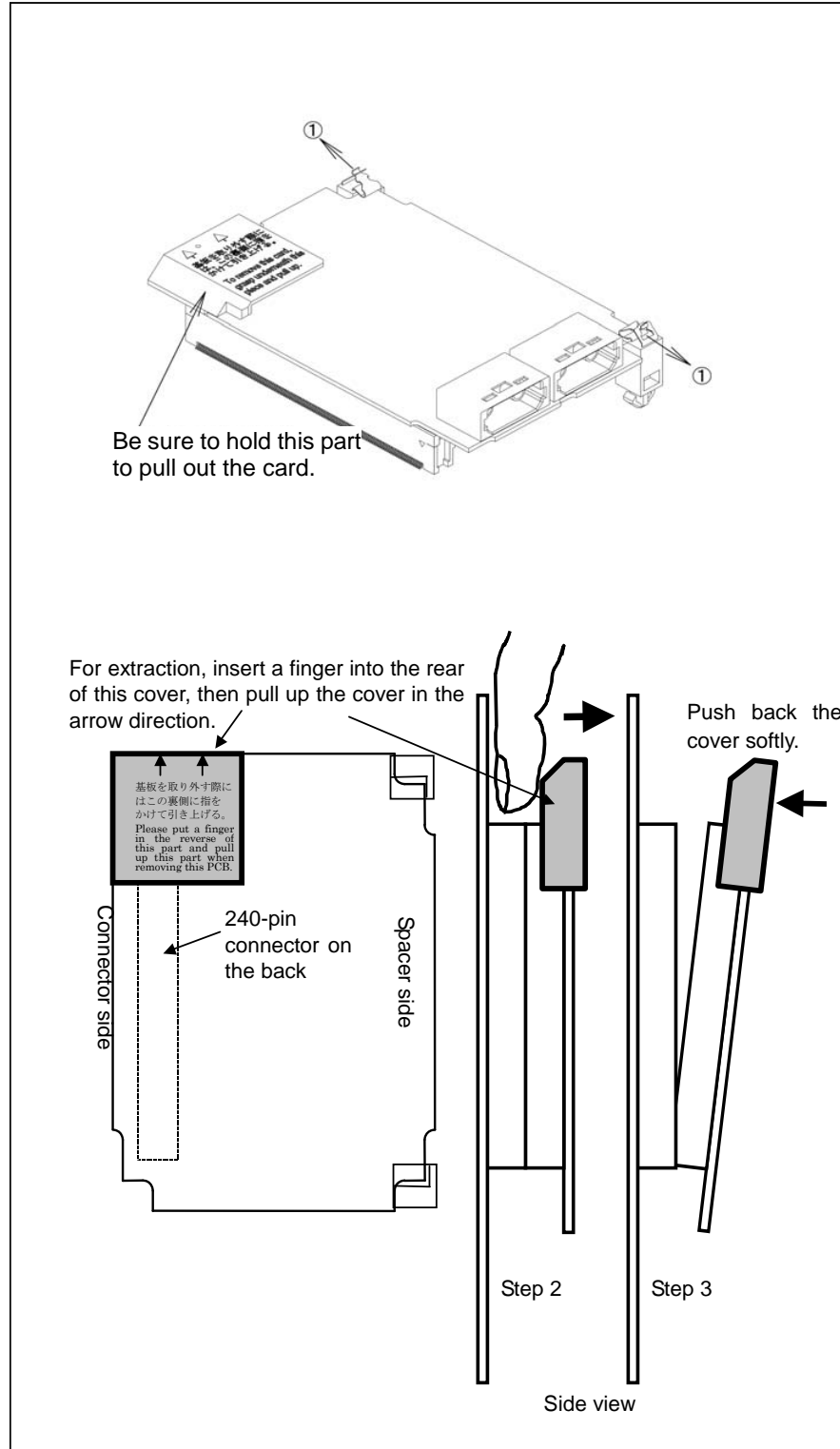


Fig.7.2 (a) Demounting the card on the main board

Mounting a Card

- (1) Check that the metal fittings of the spacers are raised.
- (2) To align the board insertion position, touch the spacer end faces of the board with the spacer as shown in the figure below. (At this time, the board is touching the spacers only).

- (3) While aligning the board with the spacers, lower the connector side slowly until the connectors touch each other (do not press until aligned).
- (4) The mating position can be determined more easily by moving the card back and forth until the alignment “nubs” and “holes” are aligned on the connectors. The board must be turned to view the board connectors on the side.

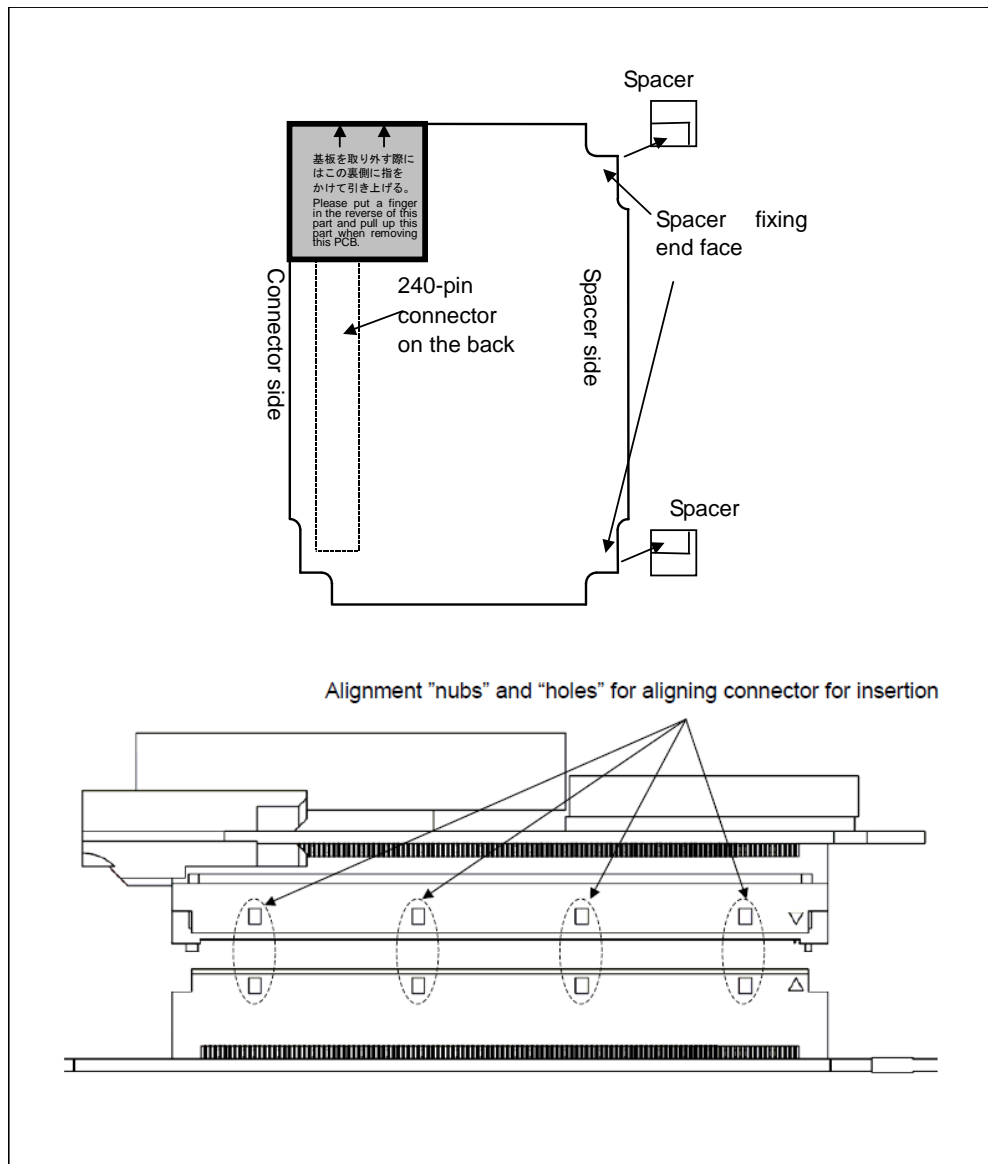


Fig.7.2 (b) Mounting the card on the main board

- (5) At this time, push on the back of the board over the connector. The force required for connector insertion is about 10 kgf. If the connector will not insert easily, re-check the alignment of the connector to prevent damaging the connector(s). Do not press the radiation fin installed on the CPU and LSI chip. Otherwise, the CPU or LSI chip can be damaged.
- (6) Push in the spacer metal fitting to lock the board in place.

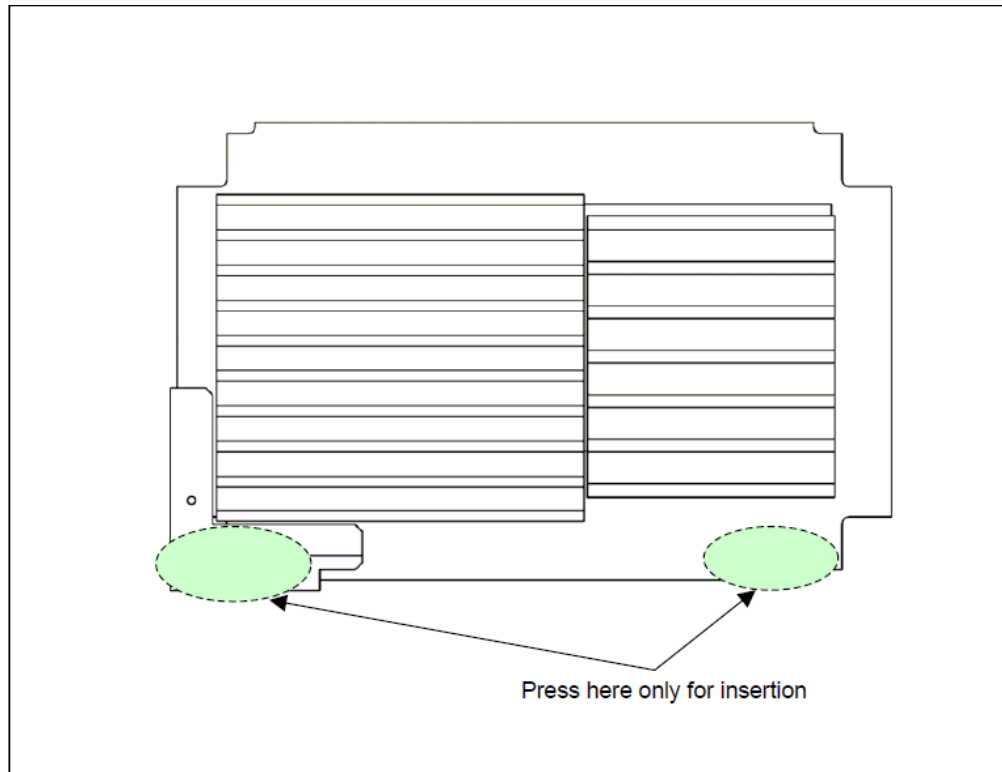


Fig.7.2 (c) Pushing location when mounting the board (top view of MAIN CPU board).

⚠ WARNING

Do not press the radiation fins installed on a CPU and LSI chip. Otherwise, CPU card may be broken.

Demounting a module

⚠ CAUTION

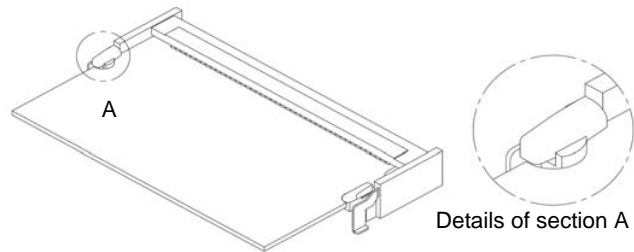
When replacing the module, be careful not to touch the module contact. If you touch the contact inadvertently, wipe out dirt on the contact with a clean cloth.

- (1) Move the clip of the socket outward. (a)
- (2) Extract the module by raising it at a 30 degree slant and pulling outward.

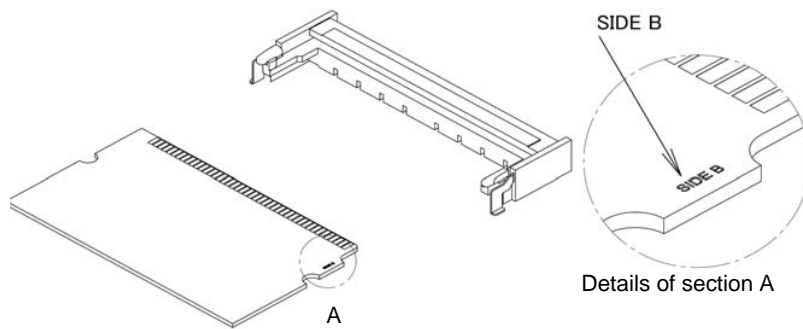
Mounting a module

- (1) Insert the module at a 30-degree slant into the module socket, with side B facing upward. (b)
- (2) Push the module inward and downward until it is locked. (c)

(a)



(b)



(c)

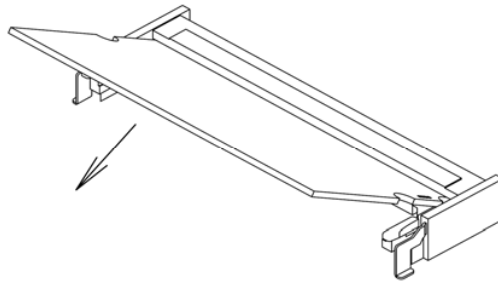
**Fig.7.2 (d) Demounting/mounting a module**

Figure 7.2 (d) shows the locations of the cards and modules.

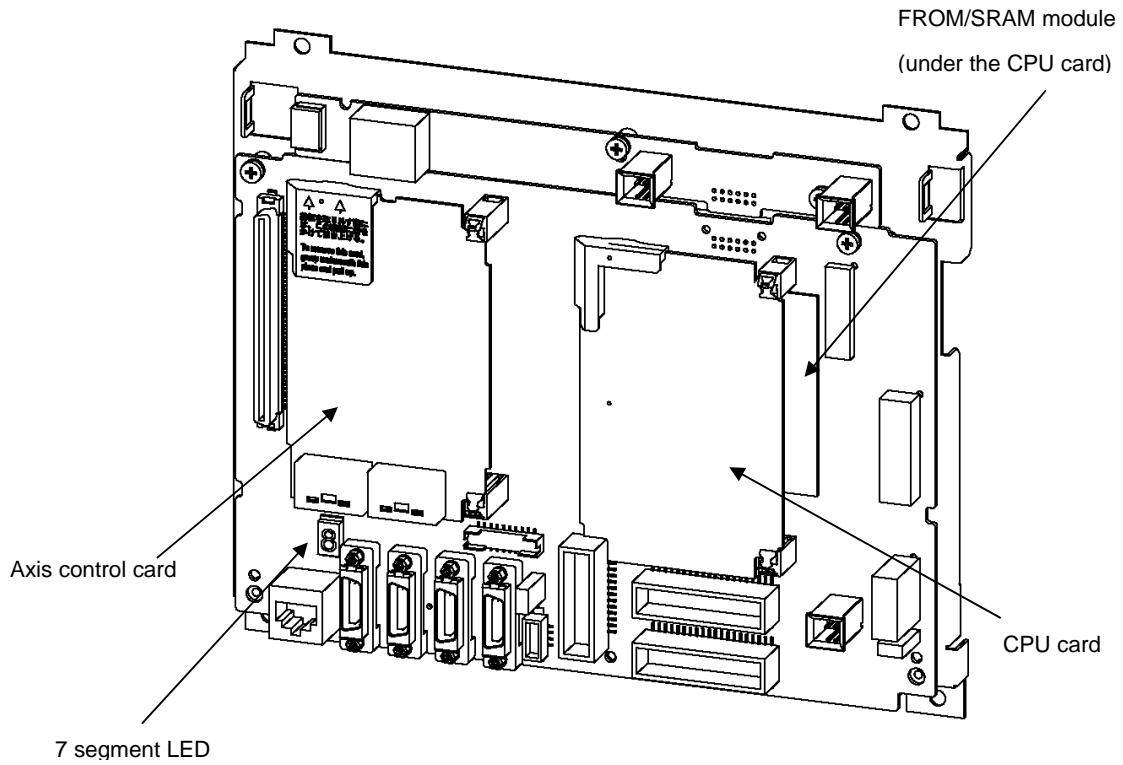


Fig.7.2 (e) Locations of cards and modules

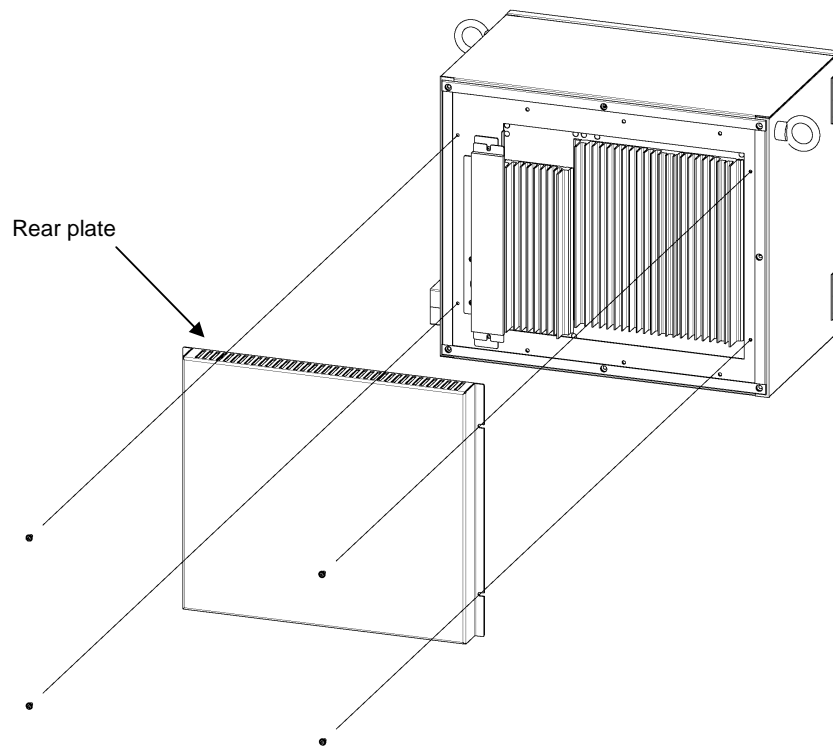
7.3 REPLACING THE REGENERATIVE RESISTOR UNIT

WARNING

Before you start, turn off the controller main power. Be careful not to get burned, because the regenerative resistor unit is very hot immediately after operation.

In case of LR Mate 200iC, M-1iA

- (1) Remove the four screws fastening the rear plate of the cabinet, and remove the rear plate.
- (2) Unplug connector CRR45 and CRR63 at the Servo amplifier.
- (3) Unscrew the retaining screws on the regenerative resistor unit and remove it.
- (4) Install the replacement unit by reversing this procedure (1) to (3).



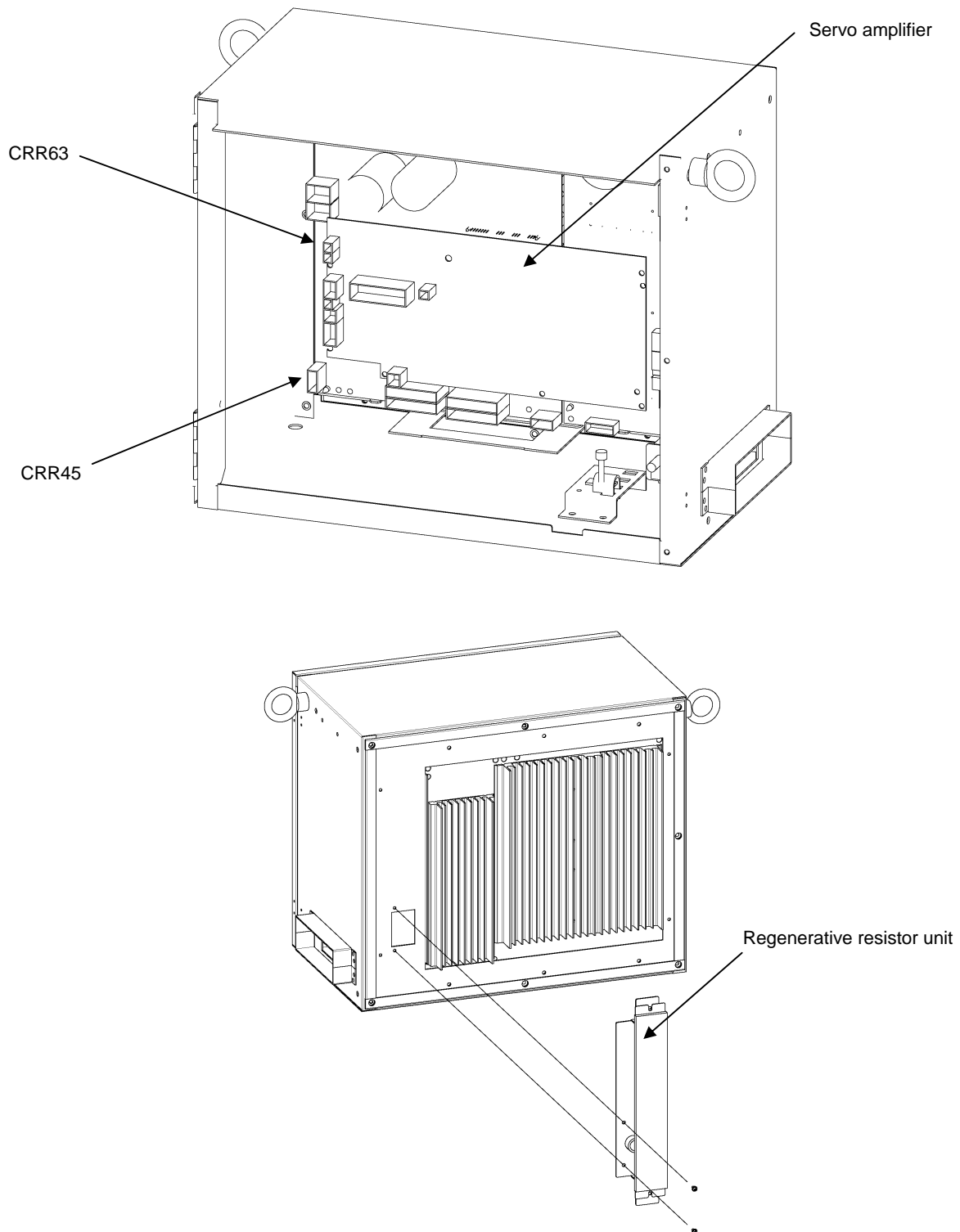
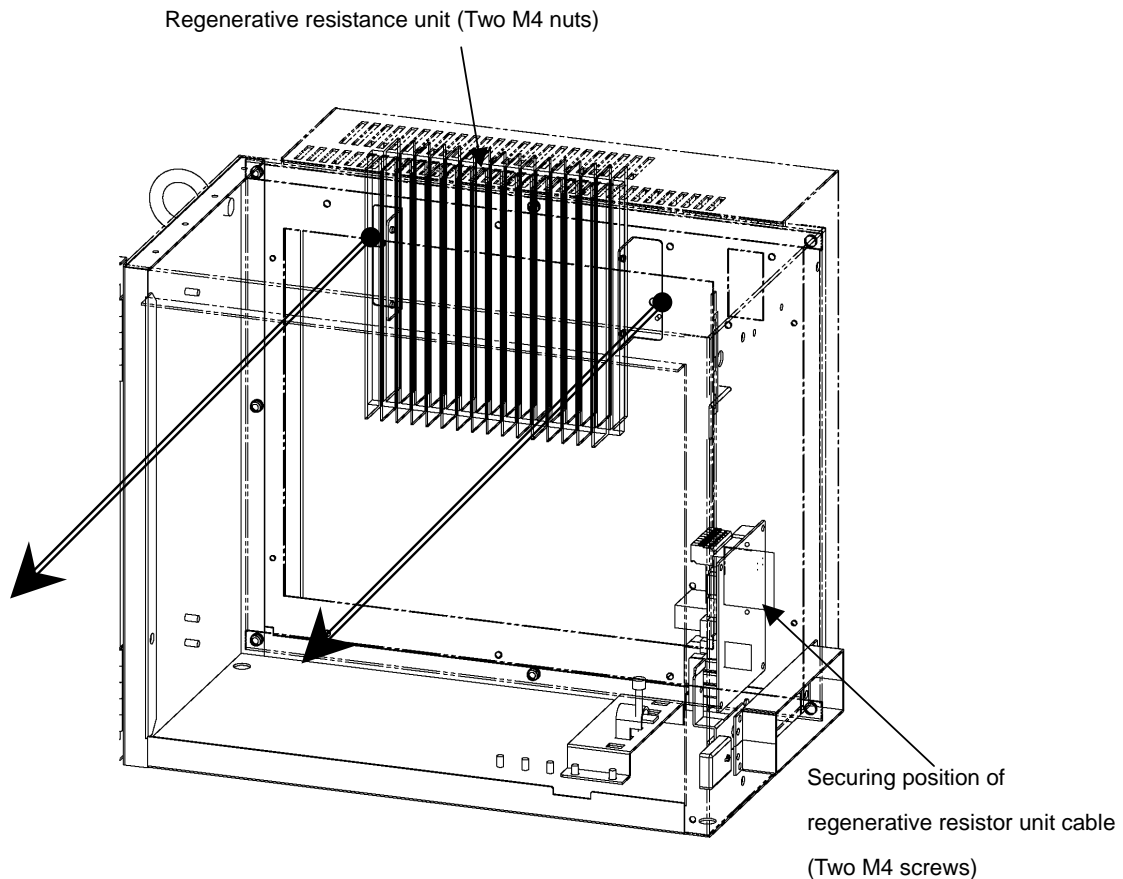


Fig.7.3 (a) Replacing the regenerative resistor unit (LR Mate 200iC, M-1iA)

In case of ARC Mate 100iC, M-10iA, ARC Mate 120iC, M-20iA, ARC Mate 50iC, ARC Mate 0iA

- (1) Remove the servo amplifier from the front of the cabinet. For details, see Section 7.5.
- (2) Remove the metal plate securing the cable of the regenerative resistor unit.
- (3) Of the two nuts securing the regenerative resistor unit, remove the upper nut, loosen the lower nut, and remove the regenerative resistor unit.
- (4) Install a new regenerative unit by reversing steps (1) to (3) above.



**Fig.7.3 (b) Replacing the regenerative resistor unit
(ARC Mate 100iC, M-10iA, ARC Mate 120iC, M-20iA, ARC Mate 50iC, ARC Mate 0iA)**

7.4 REPLACING THE E-STOP UNIT

- (1) Detach the cables from the emergency stop unit.
- (2) Remove the three nuts fastening the E-stop unit, and replace the E-stop unit.
- (3) Reconnect the cables.

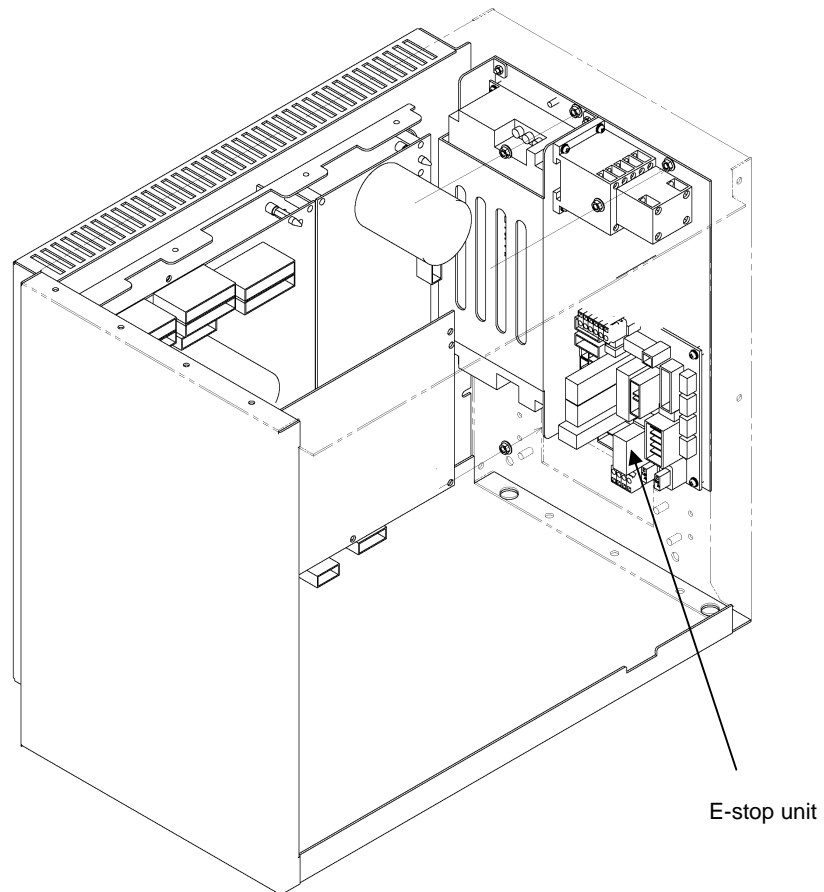


Fig.7.4 Replacing the E-stop unit

7.5 REPLACING SERVO AMPLIFIERS



CAUTION

Because the servo amplifier is heated immediately after operation, leave the servo amplifier until it cools down thoroughly, before replacing it.

- (1) Open the door, and check the DC link voltage at the screws above the LED "D7", using a DC power supply voltmeter. The voltage reading must be 50 V or lower.

Check that the voltage is not higher than 50V.

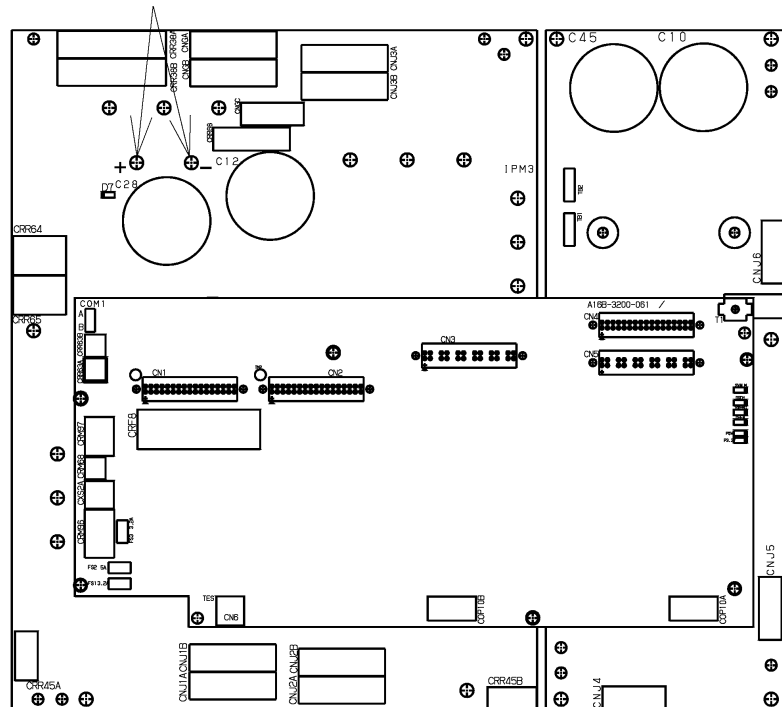


Fig.7.5 (a) Servo amplifier



WARNING

Before touching the servo amplifier, check the DC link voltage with the screws located above the LED "D7". By using a DC voltage tester, check that the voltage is 50 V or less.

- (2) Detach the cables from the servo amplifier.
- (3) Remove the two screws fastening the servo amplifier.

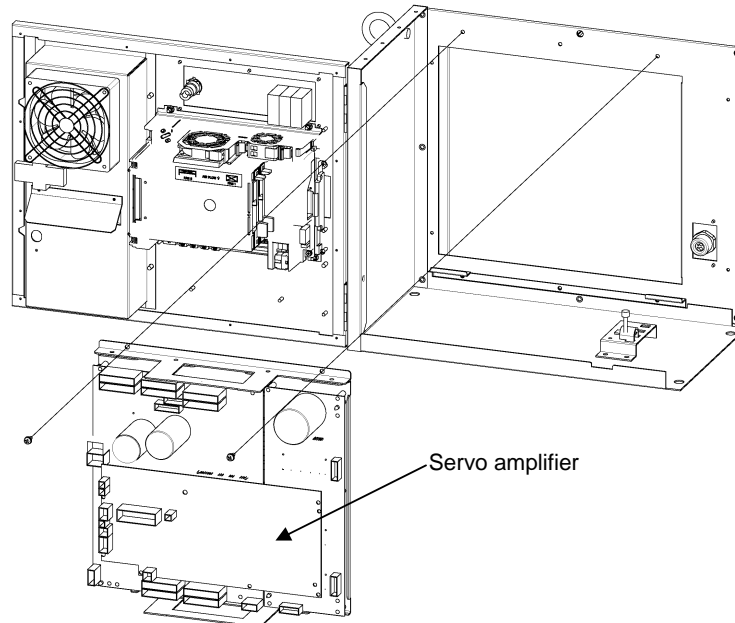


Fig.7.5 (b) Replacing the servo amplifier

- (4) Hold the handles located in the upper and lower parts of the servo amplifier, and remove the servo amplifier.
- (5) Reverse steps (2) to (4) above to install a new servo amplifier.

The servo amplifier can also be removed together with the metal plate of the rear of the cabinet.

- (6) Remove the eight screws fastening the metal plate, and remove the metal plate and the servo amplifier at a time.

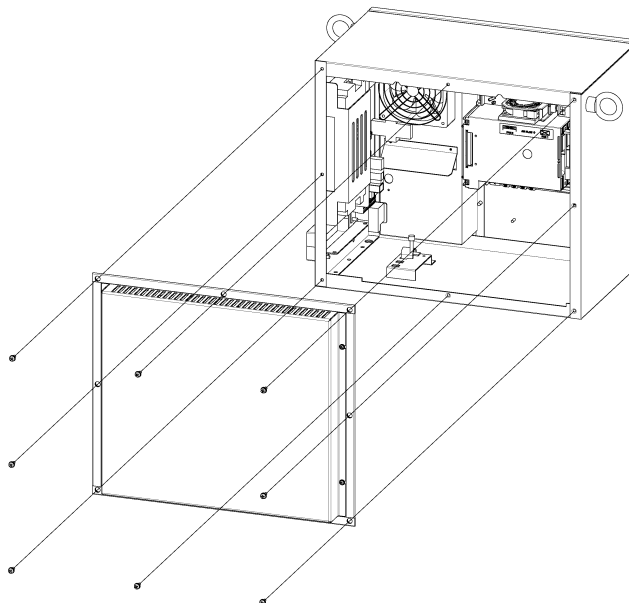


Fig.7.5 (c) Replacing the servo amplifier from rear side

7.6 REPLACING THE TEACH PENDANT and *i* PENDANT

The specifications of the teach pendant vary with its use. When you replace the teach pendant, check its specifications carefully.

- (1) Be sure that the power of a robot controller is off.
- (2) Detach the cable from the teach pendant.
- (3) Replace the teach pendant.

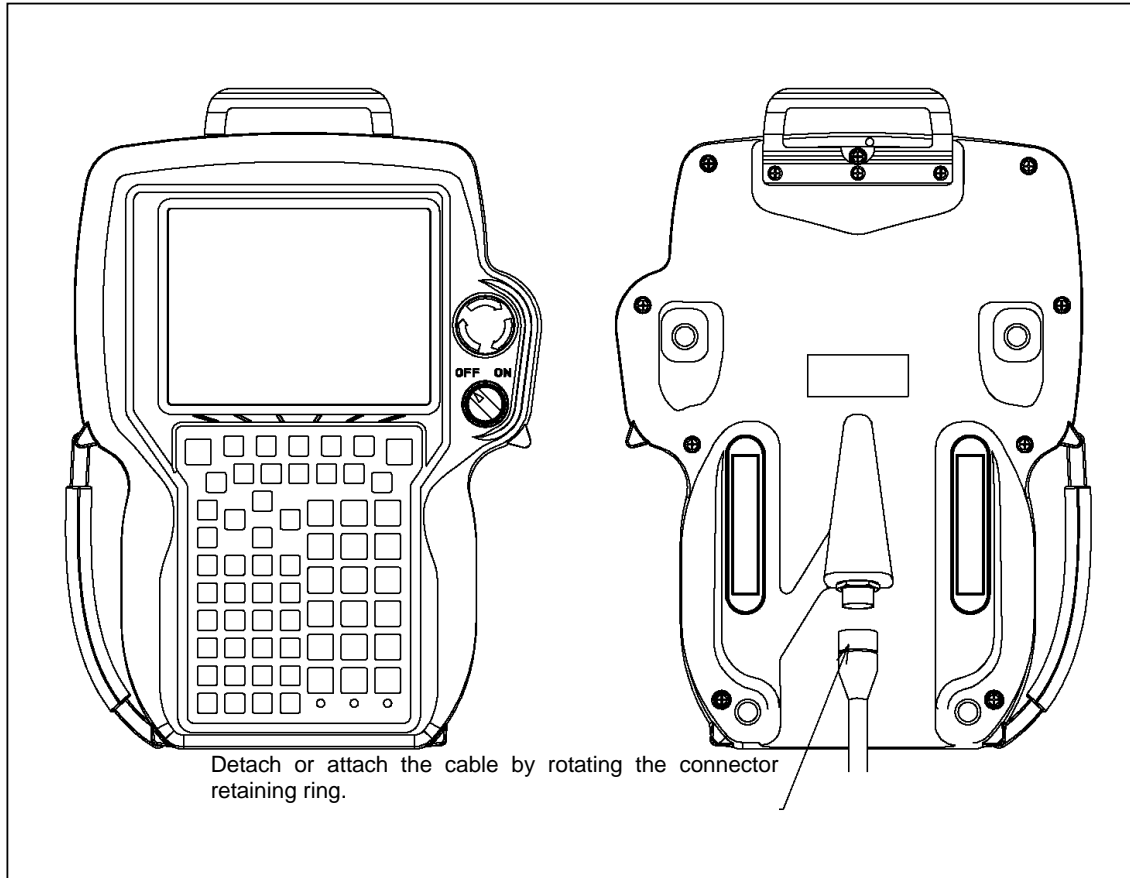
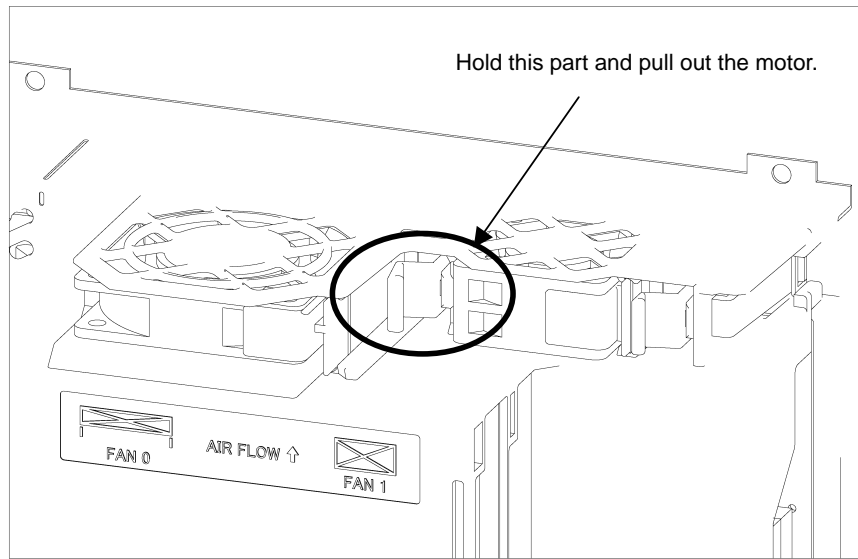


Fig.7.6 Replacing the teach pendant

7.7 REPLACING THE CONTROL SECTION FAN MOTOR

The control section fan motor can be replaced without using a tool. The fan motor is mounted on the fan unit rack.

- (1) Be sure that the power to the robot controller is turned off.
- (2) Pull out the fan motor to be replaced. (When pulling out the fan motor, hold the latch of the fan unit, and unlatch the unit from the case.)



- (3) Install a new fan unit. (Insert the unit until the latch of the unit snaps into the case.)

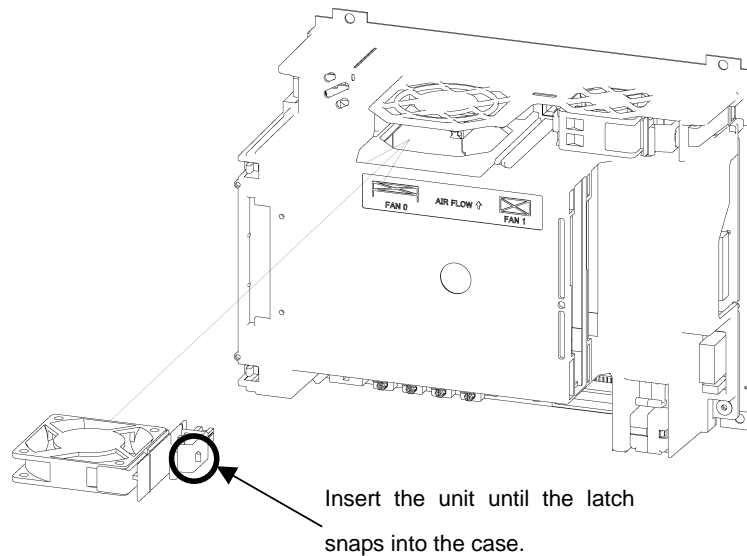


Fig.7.7 Replacing the control section fan motor

7.8 REPLACING THE AC FAN MOTOR



WARNING

Do not touch the fan motor when it is rotating, or you could be injured.

7.8.1 Replacing External Air Fan Unit and Door Fan

The cabinet has a heat exchanger inside the door.

Before replacing the heat exchanger, you must detach the door fan unit.

Door fan unit

- (1) Remove the four M4 retaining screws.
- (2) Remove the cables connected to the heat exchanger.
- (3) Mount a spare fan unit by reversing the removal procedure.

Heat exchanger

- (1) Remove the door fan unit (see the descriptions above).
- (2) Open the door of the cabinet, and remove the cables.
- (3) Remove the four M5 retaining nuts, and detach the heat exchanger.
- (4) Mount a spare heat exchanger by reversing the removal procedure.

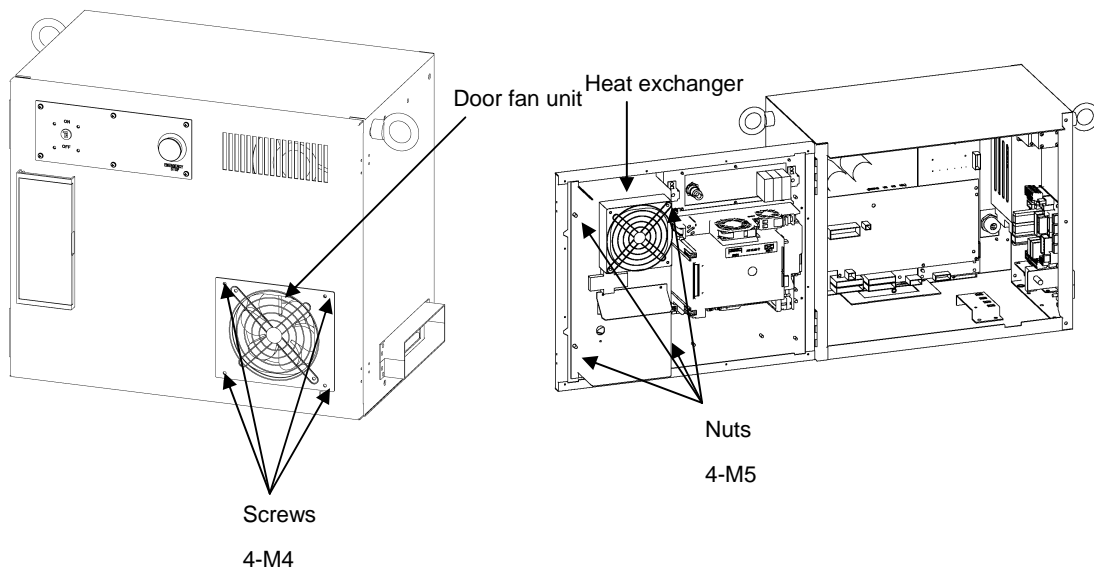


Fig.7.8.1 (a) Replacing the door fan unit

Fig.7.8.1 (b) Replacing the heat exchanger

Rear fan unit (for the ARC Mate 100iC/M-10iA, ARC Mate 120iC, M-20iA, ARC Mate 0iA)

- (1) Remove the six securing screws (M4) and remove the unit.
- (2) Remove the connected cables.
- (3) Mount a spare fan unit by reversing the removal procedure.

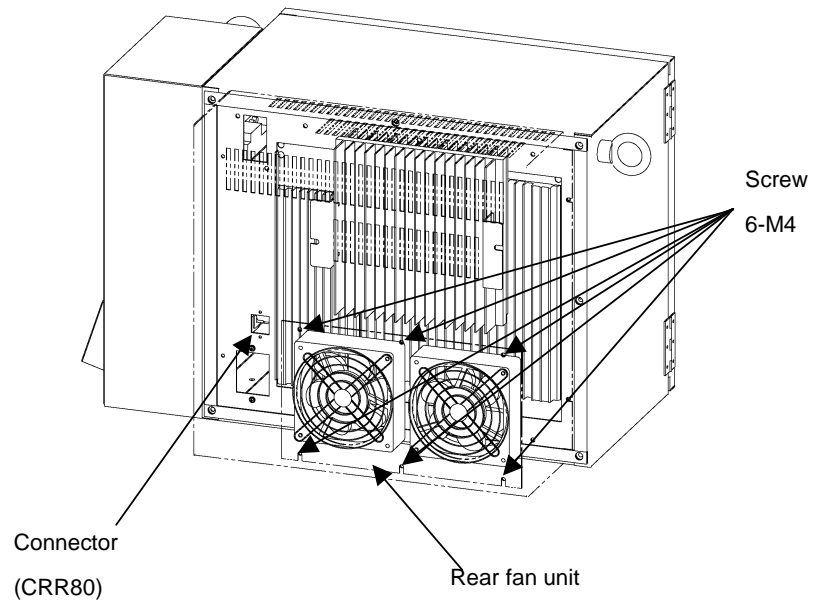


Fig.7.8.1 (c) Replacing the rear fan unit

7.9.2 Replacing Fuses in the Main Board

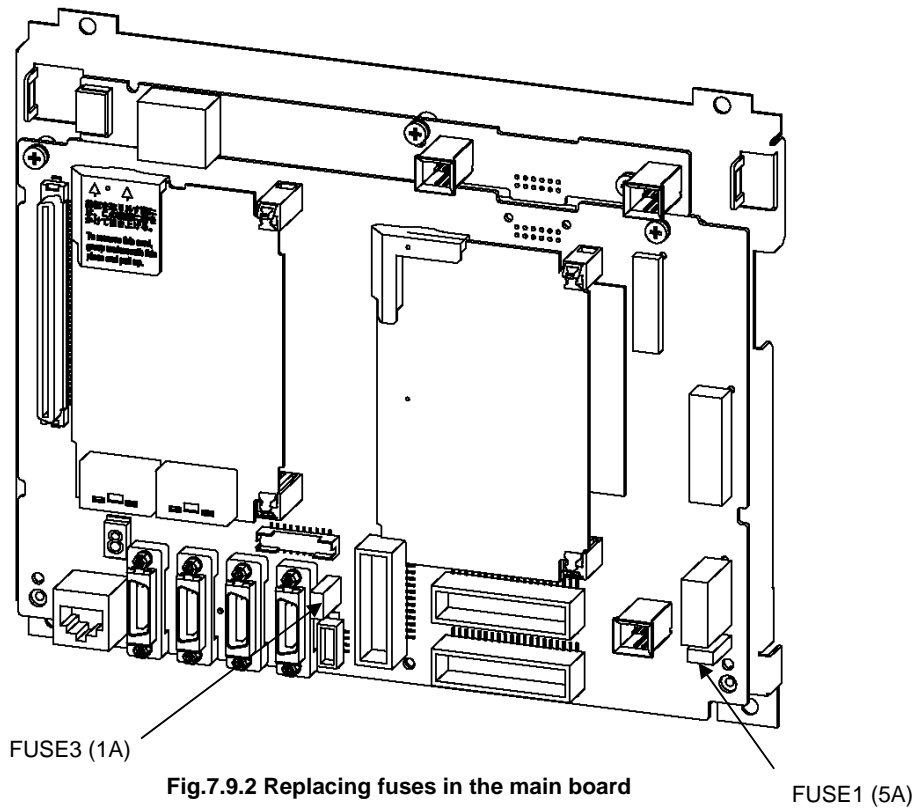
The following fuses are in the main board.

FUSE1: Fuse for protecting the +24V output:

A60L-0001-0290#LM50C

FUSE3: Fuse for protecting the +24V output for peripheral equipment interfaces:

A60L-0001-0290#LM10C



7.9.3 Replacing the Fuse on the E-stop Boards

The emergency stop board has the following fuses:

- FUSE1 For protecting +24EXT to the emergency stop circuit: A60L-0001-0046#1.0
- FUSE2: For protecting +24V to the teach pendant: A60L-0001-0046#1.0
- FUSE3: For protection of the +24V: A60L-0001-0046#2.0
- FU1 and FU2: For door fan input protection: A60L-0001-0175#0.5A

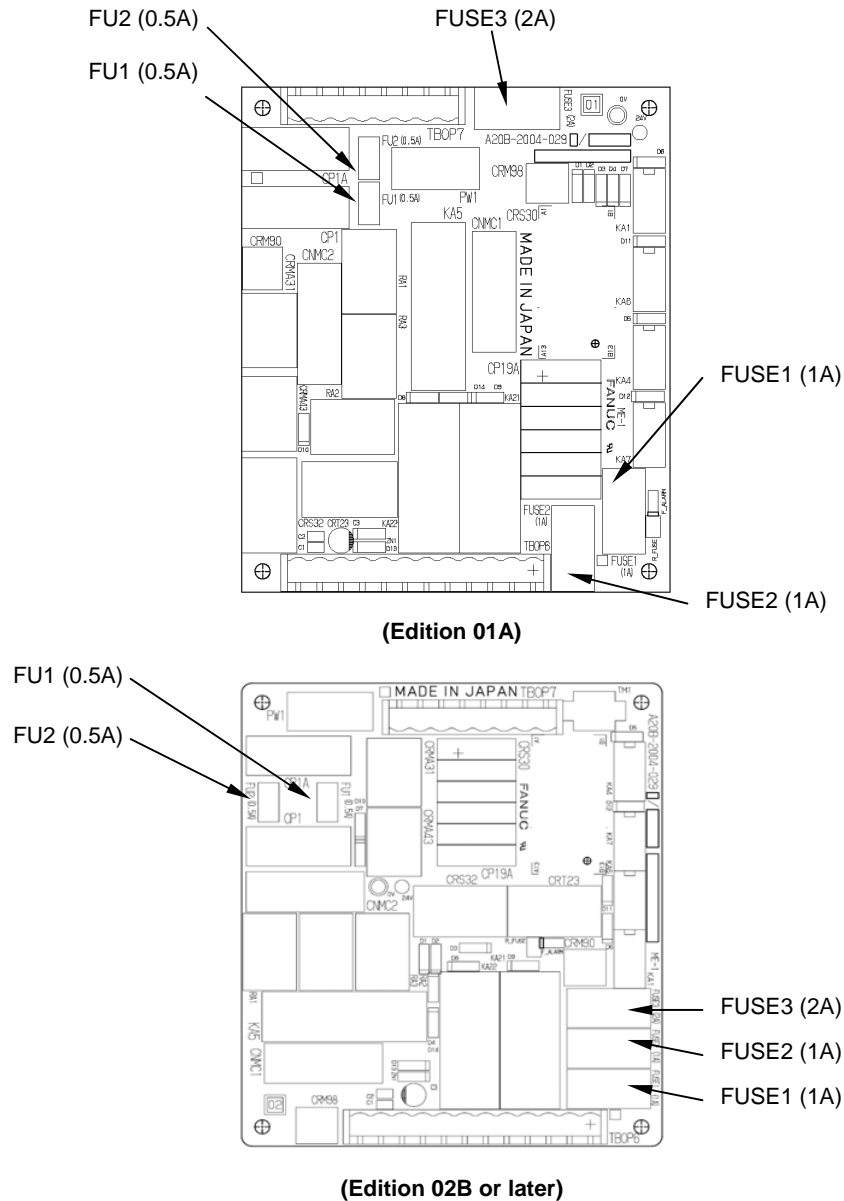


Fig.7.9.3 Emergency stop board

7.10 REPLACING RELAYS

Prolonged use of a relay might result in its contacts failing to make a secure connection or sticking to each other permanently. If such a failure occurs, replace the relay.

7.10.1 Replacing Relays on the E-stop Board

KA21, KA22 For the emergency stop circuit:
PW1 For the 200-V power supply:

A58L-0001-0192#1997R
A58L-0001-0548#AQC145

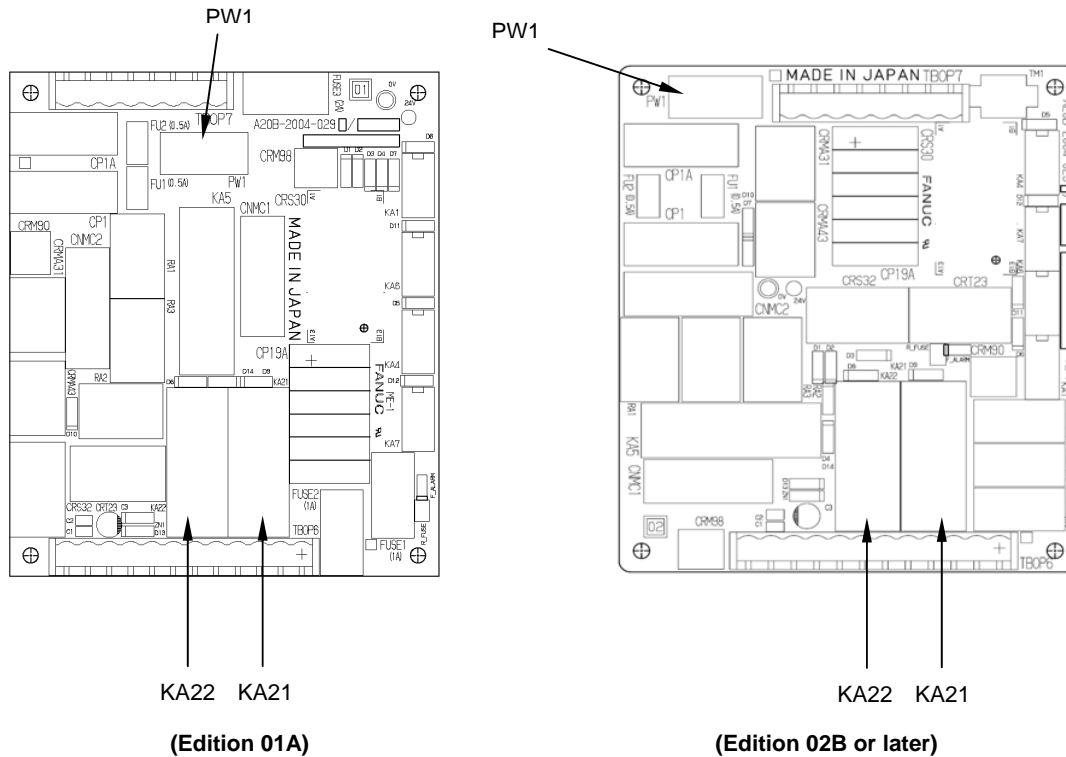


Fig.7.10.1 Replacing relays on the emergency stop board

7.11 REPLACING BATTERY

7.11.1 Battery for Memory Backup (3 VDC)

The programs, and system variables are stored in the SRAM in the main board. The power to the SRAM memory is backed up by a lithium battery mounted on the front panel of the main board. The above data is not lost even when the main power of controller is turned off. A new battery can maintain the contents of memory for about 4 years (Note).

When the voltage of the battery becomes low, the low-voltage battery alarm (system-035) is displayed on the teach pendant. When this alarm is displayed, replace the battery as soon as possible. In general, the battery can be replaced within one or two weeks, however, this depends on the system configuration.

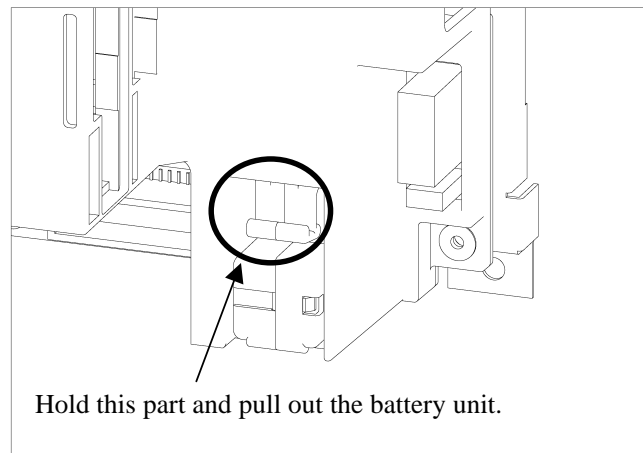
If the battery voltage gets lower, it becomes impossible to back up the content of the SRAM. Cycling power to the controller in this state causes system not to start, and LED located on the main board displays "1" because the contents of memory have been lost. Clear the entire SRAM memory and reenter data after replacing the battery. Important data should be saved to the memory card or other external device beforehand in case of emergency.

NOTE

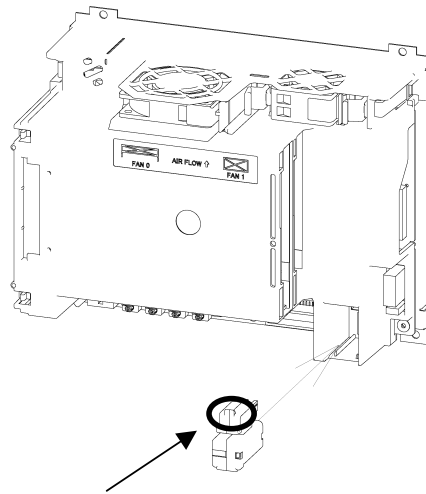
In a newly introduced robot, the battery is factory-installed. Battery replacement may, therefore, be needed within 4 years after the introduction of the robot.

Replacing the lithium battery

- (1) Prepare a new lithium battery (ordering drawing number: A05B-2550-K030).
- (2) Turn the robot controller on for about 30 seconds.
- (3) Turn the robot controller off.
- (4) Pull out the battery unit located in the lower right part of the backplane unit. (Hold the latch of the battery unit, unlatch the battery unit from the case, and pull out the unit.).



- (5) Install a new battery unit. (Insert the battery unit until the latch of the unit snaps into the case.) Check that the battery unit is latched securely.



Insert the unit until the latch snaps into the case.

Fig.7.11.1 Replacing the battery

⚠ CAUTION

Complete the steps (c) to (e) within 30 minutes.

If the battery is left disconnected for a long time, the contents of memory will be lost.

To prevent possible data loss, it is recommended that the robot data such as programs and system variables be backed up before battery replacement.

⚠ WARNING

Using other than the recommended battery may result in the battery explosion.

Replace the battery only with the specified battery (A05B-2550-K030).

Dispose of the replaced battery as an industrial waste, according to the laws and other rules in the country where the controller is installed and those established by the municipality and other organizations that have jurisdiction over the area where the controller is installed.

II. CONNECTIONS

1 GENERAL

This section describes the electrical interface connections in the R-30iA Mate. It also includes information about installation of the R-30iA Mate.

2 BLOCK DIAGRAM

Fig.2 is a block diagram of electrical interface connections with the R-30iA Mate.

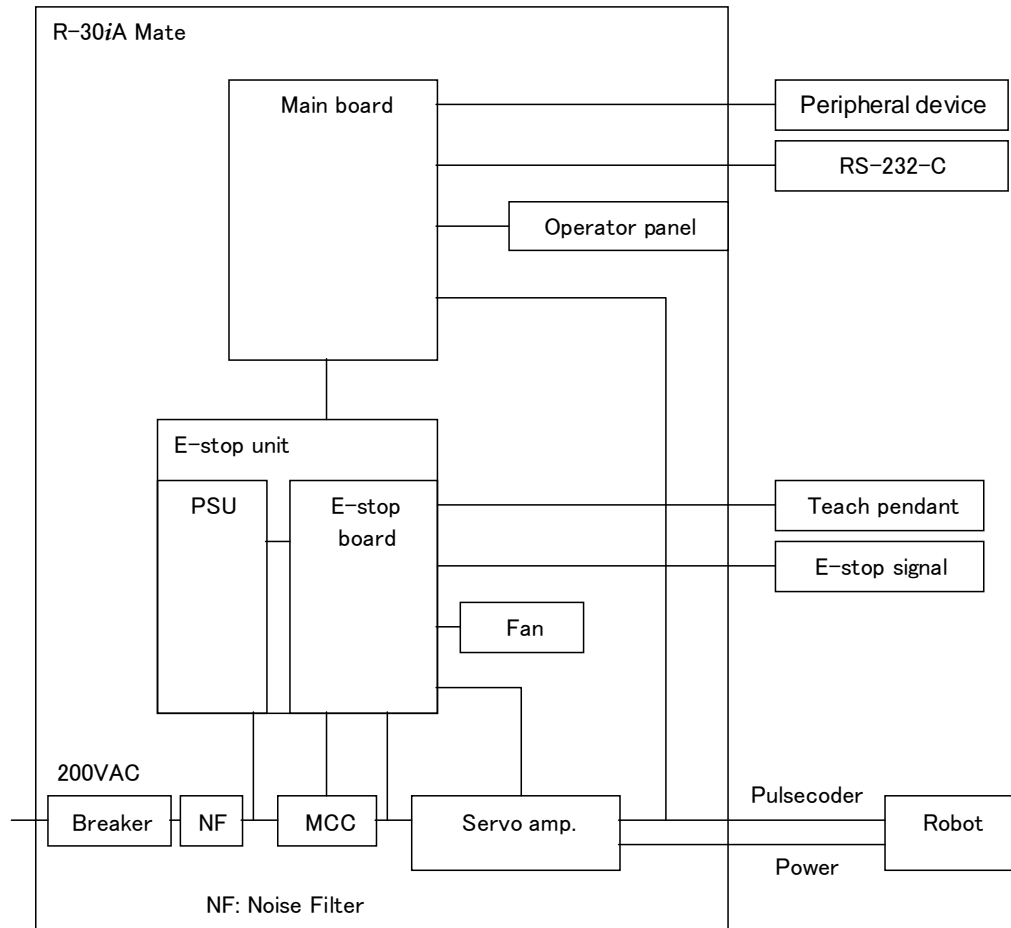


Fig.2 Block diagram of electrical interface connection

NOTE

- 1 ——— : Indicates electrical connection.
- 2 For more information, contact our service section.

3 ELECTRICAL CONNECTIONS

3.1 CONNECTION DIAGRAM BETWEEN MECHANICAL UNITS

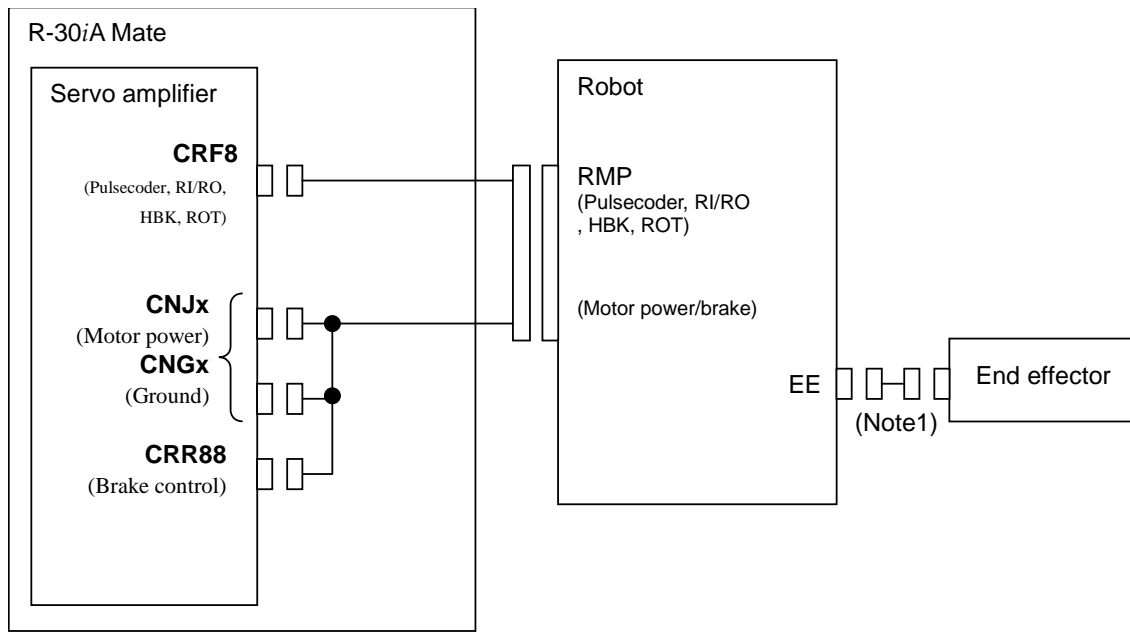


Fig.3.1 (a) Mechanical connection diagram

NOTE1

This cable is not included. It must be supplied by the customer.

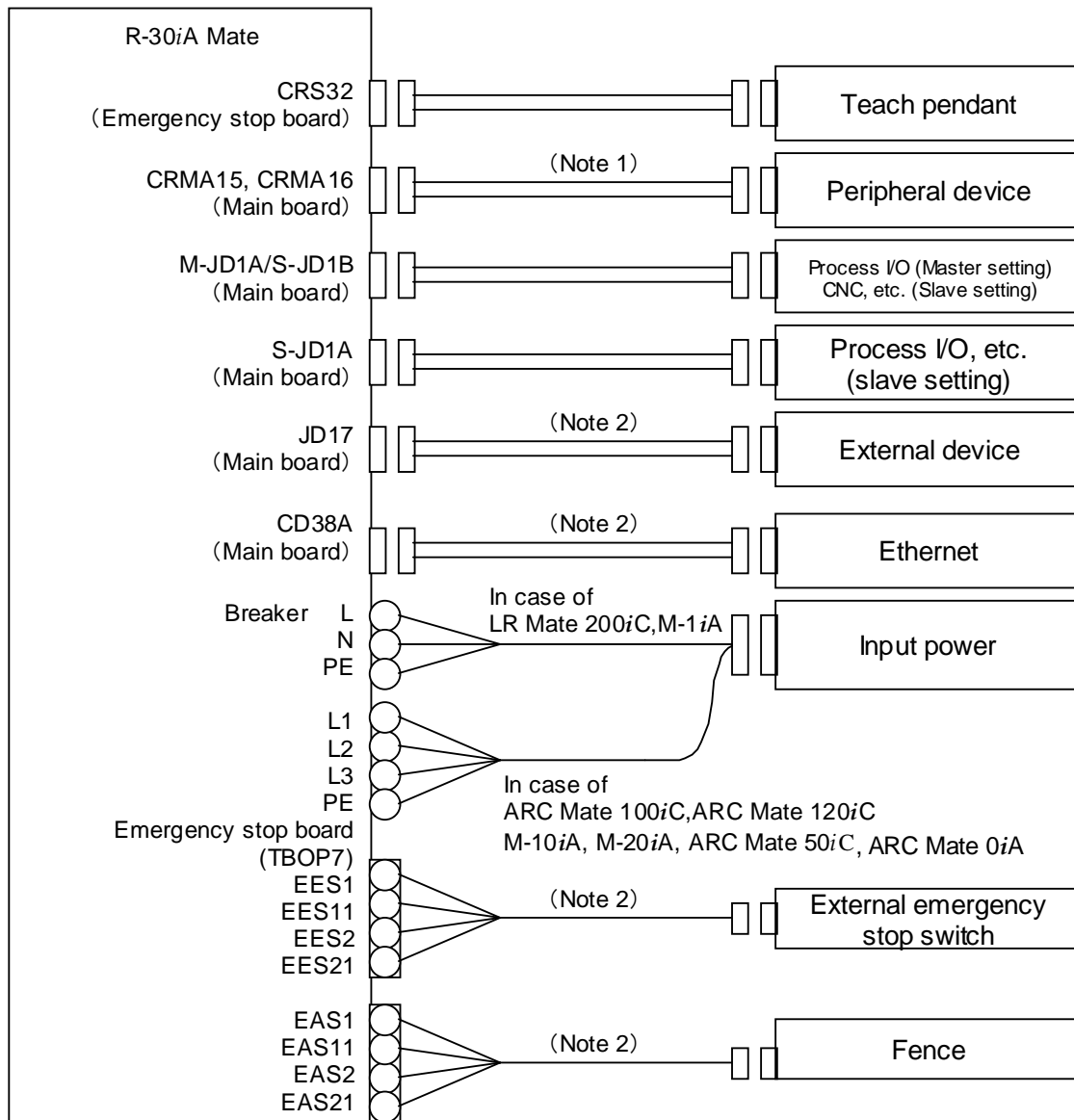


Fig.3.1 (b) Mechanical connection unit

NOTE

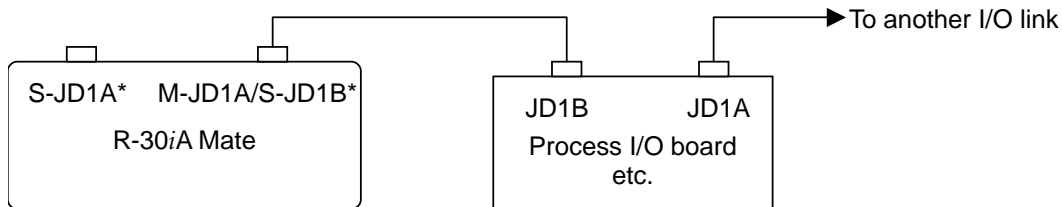
- 1 For detail of the peripheral device connection, see the section of Peripheral device interface.
- 2 This cable is not included. It must be supplied by the customer.

3.2 FANUC I/O LINK

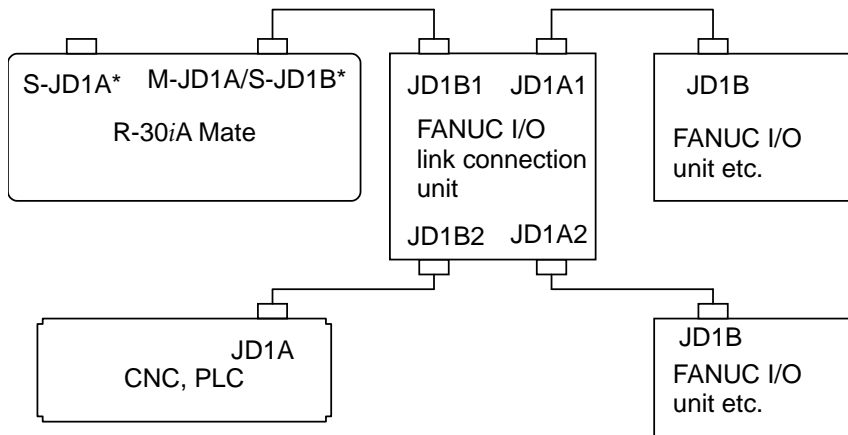
3.2.1 Connection of I/O Link

The connection of I/O links in the R-30iA Mate is shown below.

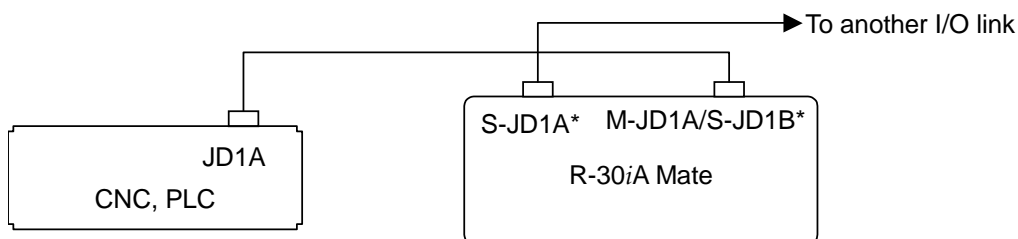
1. When the R-30iA Mate control unit is used as the I/O link master (default)
(When the R-30iA Mate control unit controls the process I/O board etc.)



2. When the R-30iA Mate control unit is connected to a CNC etc. via the I/O link connection unit



3. When the R-30iA Mate control unit is used as an I/O link slave
(When a CNC or PLC is the I/O link master)



- * M-JD1A/S-JD1B: For main board general versions equal to or earlier than 04A, the connector name is JD1A.
S-JD1A: For main board general versions equal to or earlier than 04A, the connector name is JD1B.

Fig.3.2.1 Connection of I/O links

3.2.2 Connection of I/O the Link Cable

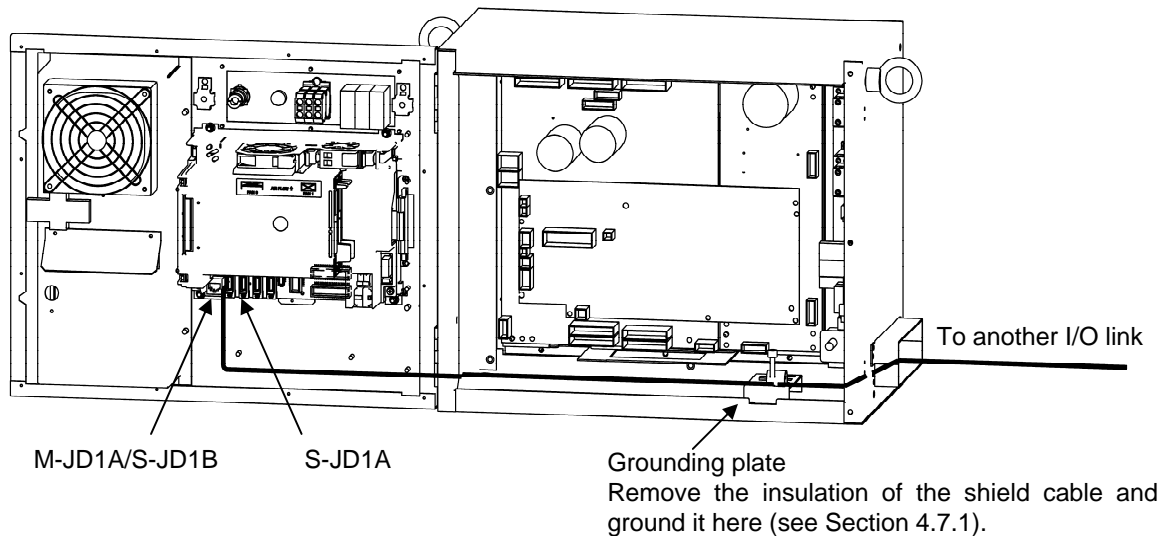


Fig.3.2.2 (a) Path of the I/O link cable

1. Connect the cable according to the system. Be sure to perform shielding.
2. Before connection, turn off the power.

NOTE

For connection with the CNC with I/O links, turn on or off the power of the CNC and the robot control unit at the following timing.

- a) A slave unit must be powered on as soon as or before the master is powered on.
- b) If the CNC or robot control unit is powered off after startup of the system, an I/O link error occurs. To successfully make connection with I/O links again, power off all of the units and then power them on at the timing indicated in a).

M-JD1A/S-JD1B interface

11	0V	01	RXSLC1
12	0V	02	*RXSLC1
13	0V	03	TXSLC1
14	0V	04	*TXSLC1
15	0V	05	
16	0V	06	
17		07	
18	(+5V)	08	
19		09	(+5V)
20	(+5V)	10	

Note: +5V is connected when the optical I/O link adapter is used.

S-JD1A interface

11	0V	01	RXSLC2
12	0V	02	*RXSLC2
13	0V	03	TXSLC2
14	0V	04	*TXSLC2
15	0V	05	
16	0V	06	
17		07	
18	(+5V)	08	
19		09	(+5V)
20	(+5V)	10	

Note: +5V is connected when the optical I/O link adapter is used.

- (1) Use a twisted-pair cable in which wires 1 and 2 are paired and wires 3 and 4 are paired.
- (2) Shield the cable collectively and ground the shield on the CNC side.

Cable connection diagram

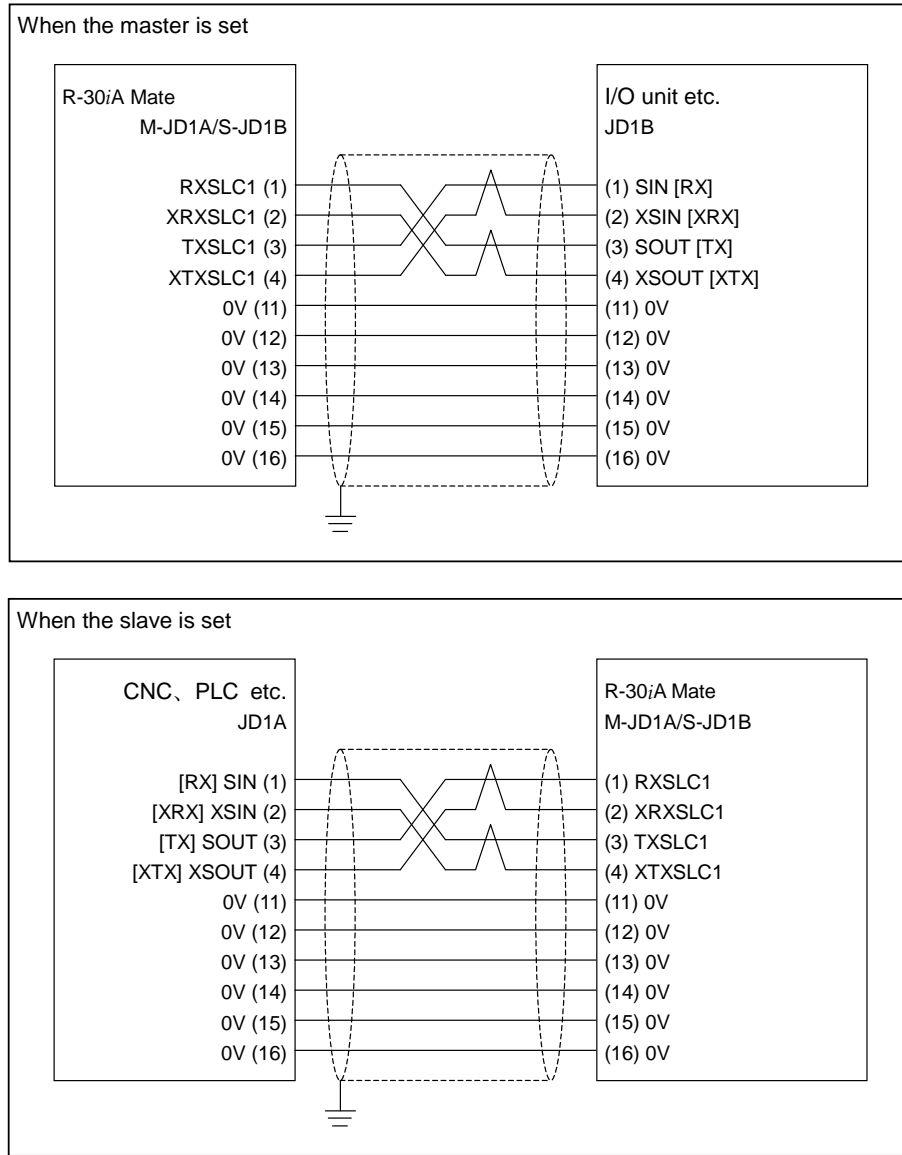


Fig.3.2.2 (b) Connection diagram of I/O Link cable

3.3 EXTERNAL CABLE WIRING DIAGRAM

3.3.1 Robot Connection Cables



CAUTION

Before operating the robot, uncoil the interconnection cables from their shipping position to prevent excessive heat, which may damage the cables.
(Coiled part should be shorter than 10 meter.)

There are two types of the robot connection cable;

Non-flex type: usage is restricted to fixed laying

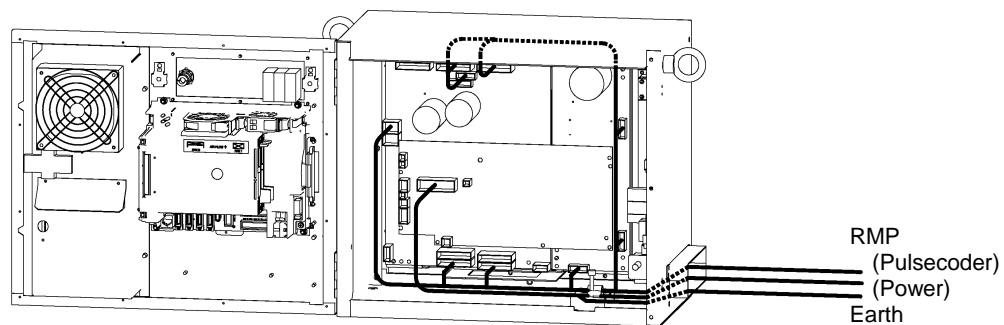
Flex type: possible to use in the cable track

Specification of cable

	Robot	Non-flex type			Flex type			
		Diameter (mm)	Weight (kg/m)	Minimum bending radius (mm)	Diameter (mm)	Weight (kg/m)	Minimum bending radius (mm)	
RMP	Signal	All models	14.2	0.31	200	-	-	-
	Power	ARC Mate 100iC ARC Mate 120iC M-10iA, M-20iA ARC Mate 0iA	20.6	1.22	200	-	-	-
		LR Mate 200iC M-1iA ARC Mate 50iC	16.1	0.75	200	-	-	-
Earth	All models	4.7	0.065	200	-	-	-	

Using condition of flex type cable

- (1) When routing cables in movable places, use a cable bearer.
- (2) The bending radius (R) of the cable track is more than 200mm.
- (3) The cable should be fixed to the cable track by using the clamp. (e.g. rubber packing)
- (4) The size of the hole to support a cable in the cable track should be more than 110% of the cable size and should have the gap more than 3mm.
- (5) When cables are laid in the cable track, pay attention for the cable not to be twisted.



- **Detail of cable connection to servo amplifier.**

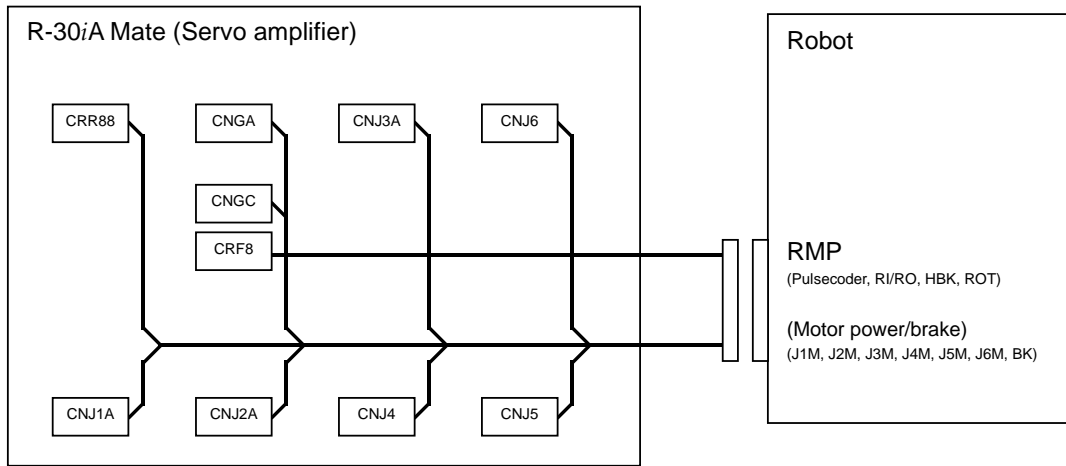


Fig.3.3.1 Robot connection cable

3.3.2 Teach Pendant Cable

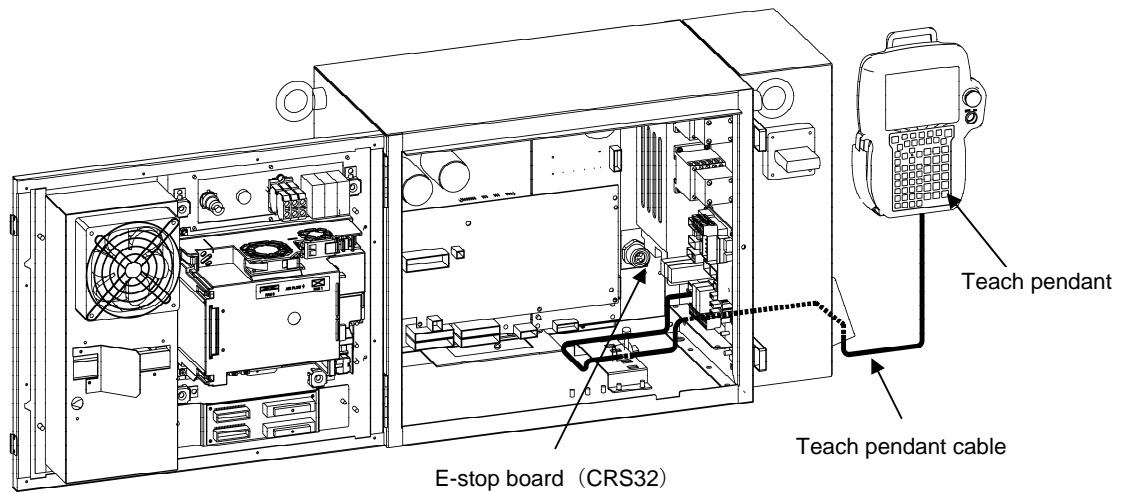


Fig.3.3.2 Teach pendant cable

3.3.3 Connecting the Input Power Supply

The input power cable should be supplied by the customer.

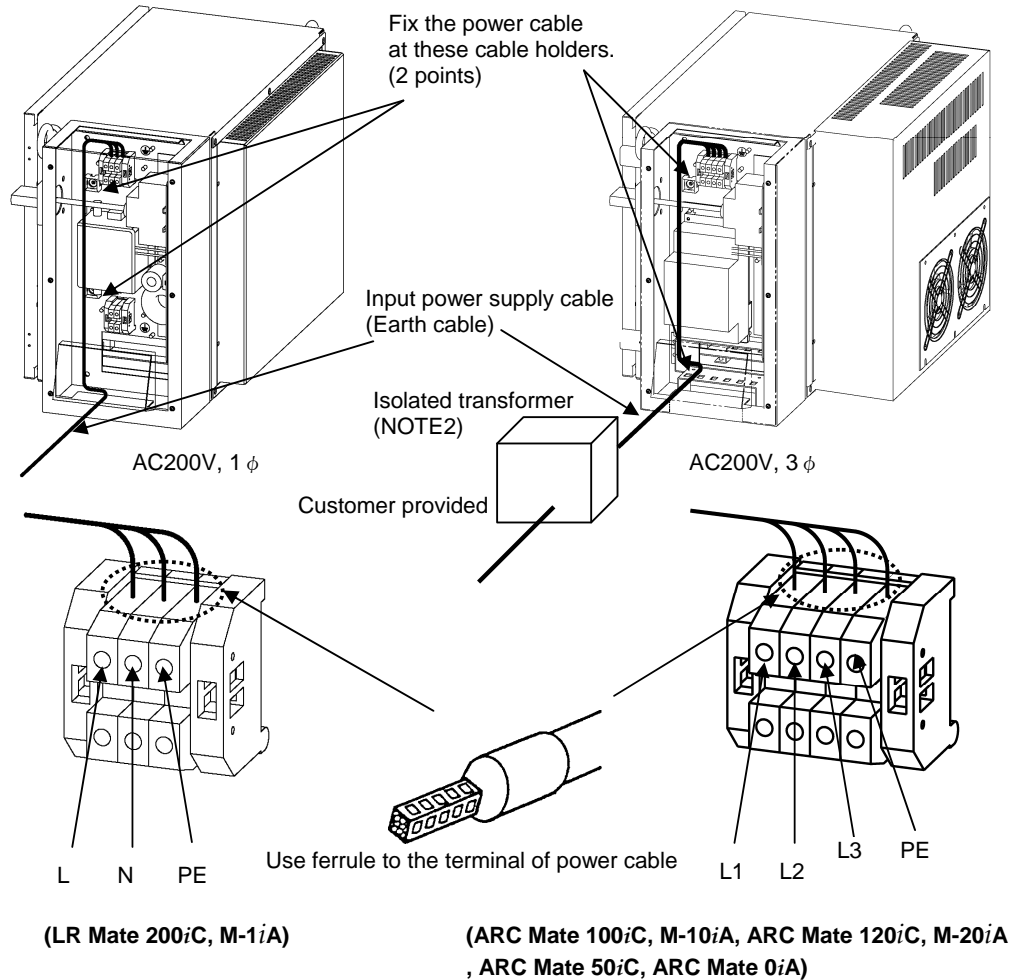


Fig.3.3.3 Input power cable

NOTE1

Use the wire which size is from AWG14 to AWG10 for input power supply cable and earth cable.

NOTE2

Example of Isolated transformer

Manufacture RIST Transformatorenbau GmbH

Specification 25065LK

Capacity 3kVA

Output AC200V

Refer to the subsection 5.4 in CONNECTIONS.

3.3.4 Connecting the External Emergency Stop

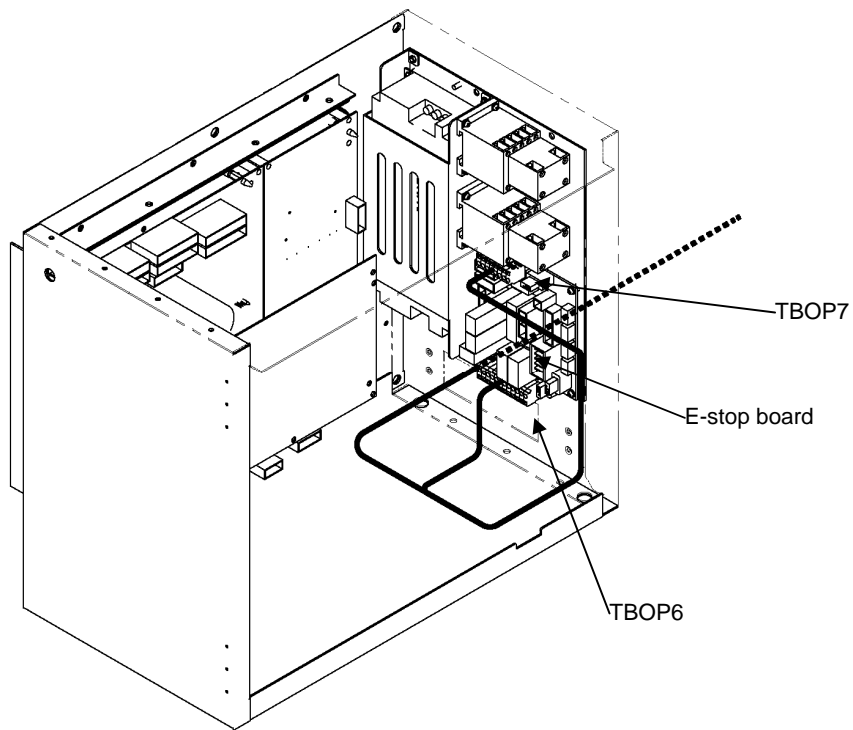
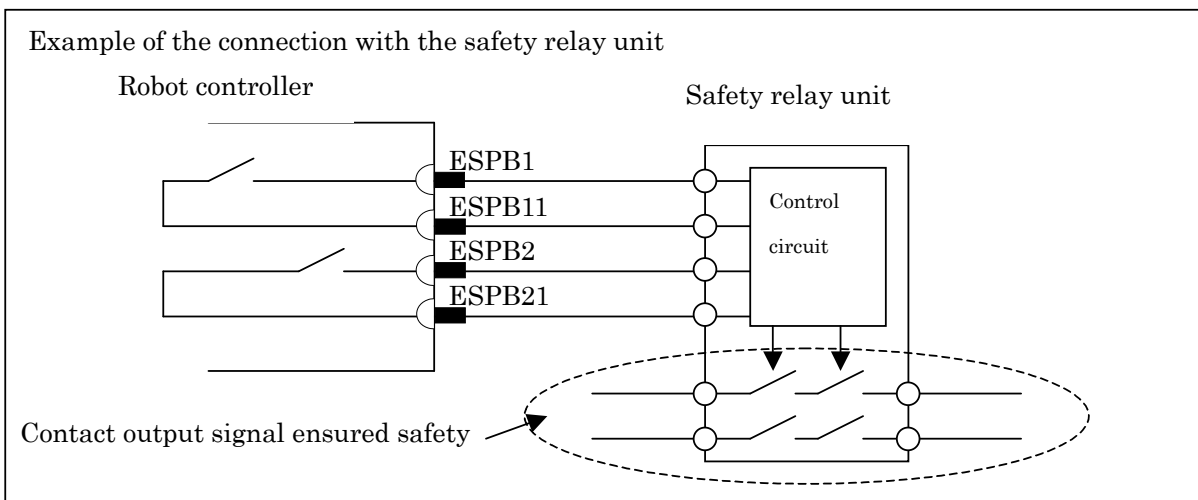
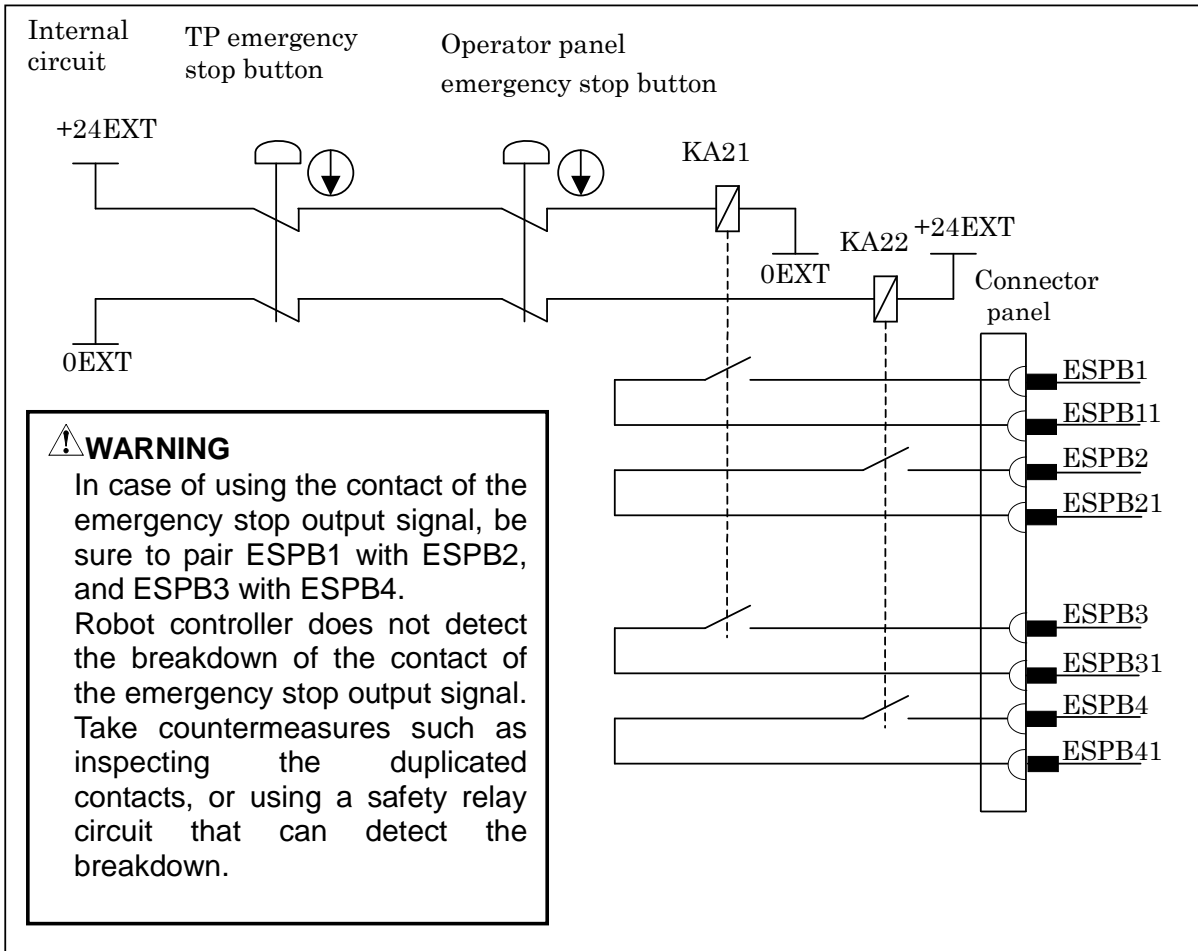


Fig.3.3.4 (a) Connection of the external emergency stop



External power connection

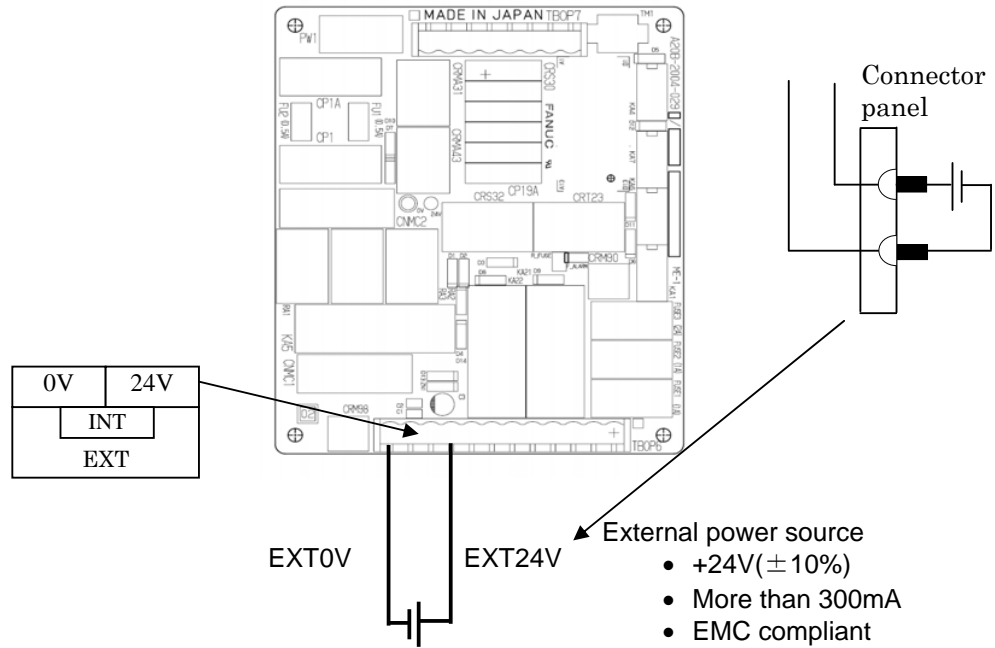
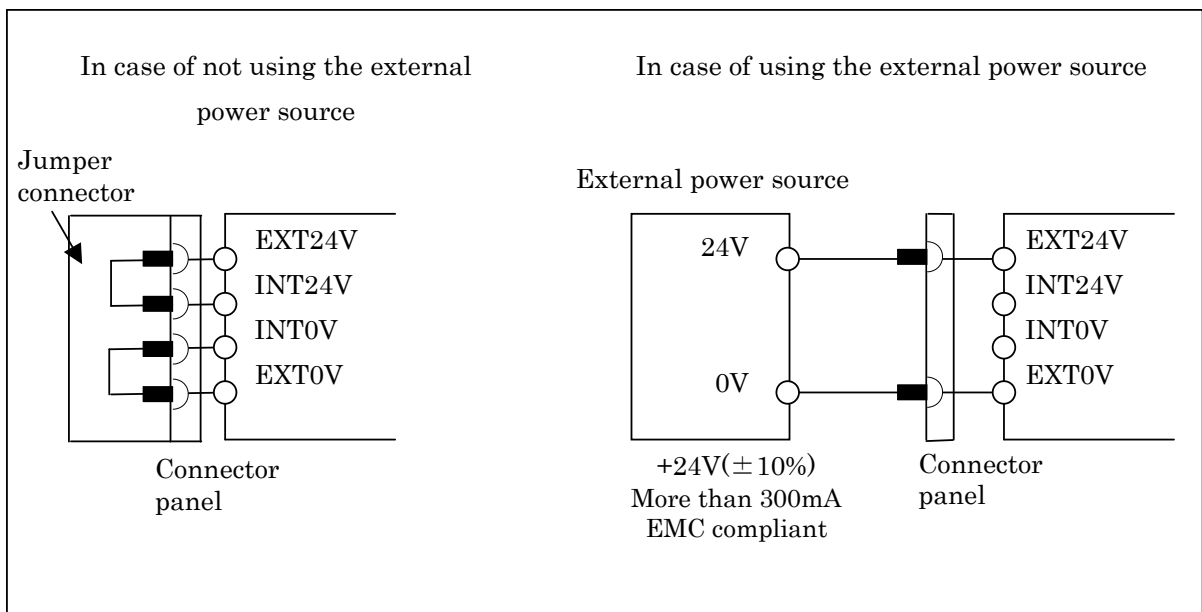


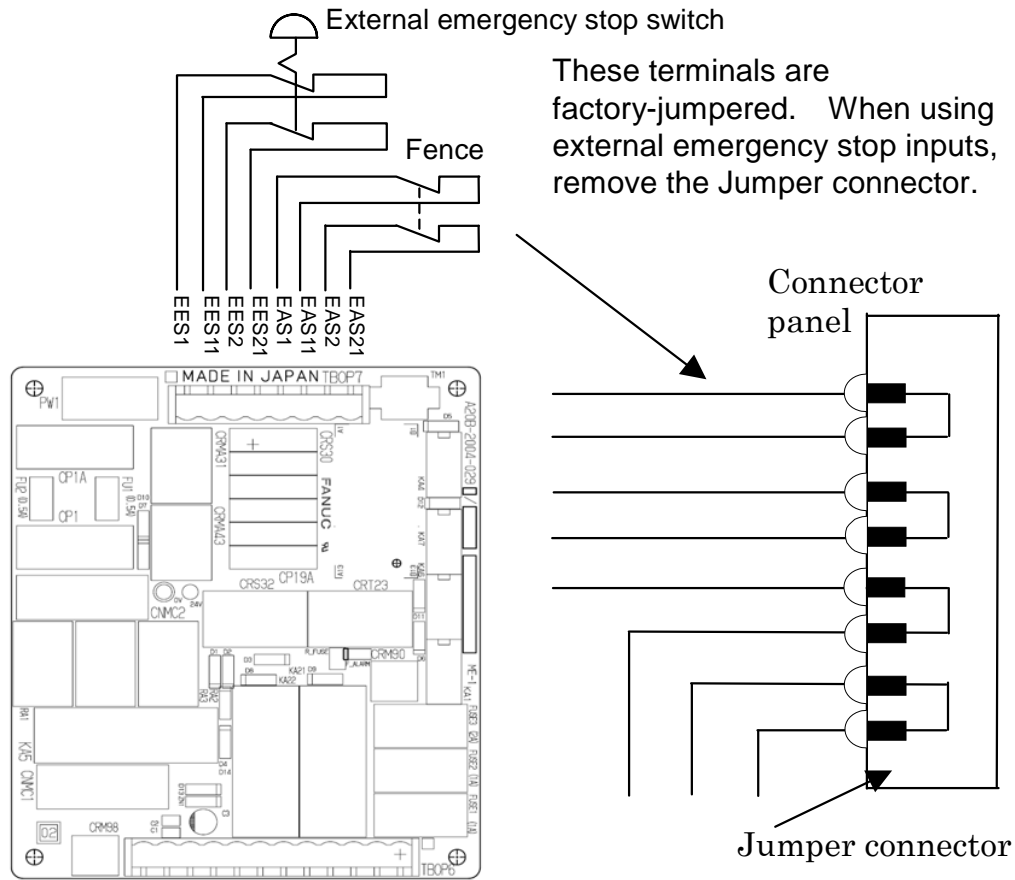
Fig.3.3.4 (d) External power connection

The relays for emergency stop input and output can be separated from controller’s power. Please connect external +24V instead of internal +24V,if emergency stop output must not be effected controller’s power.

Example of the connection

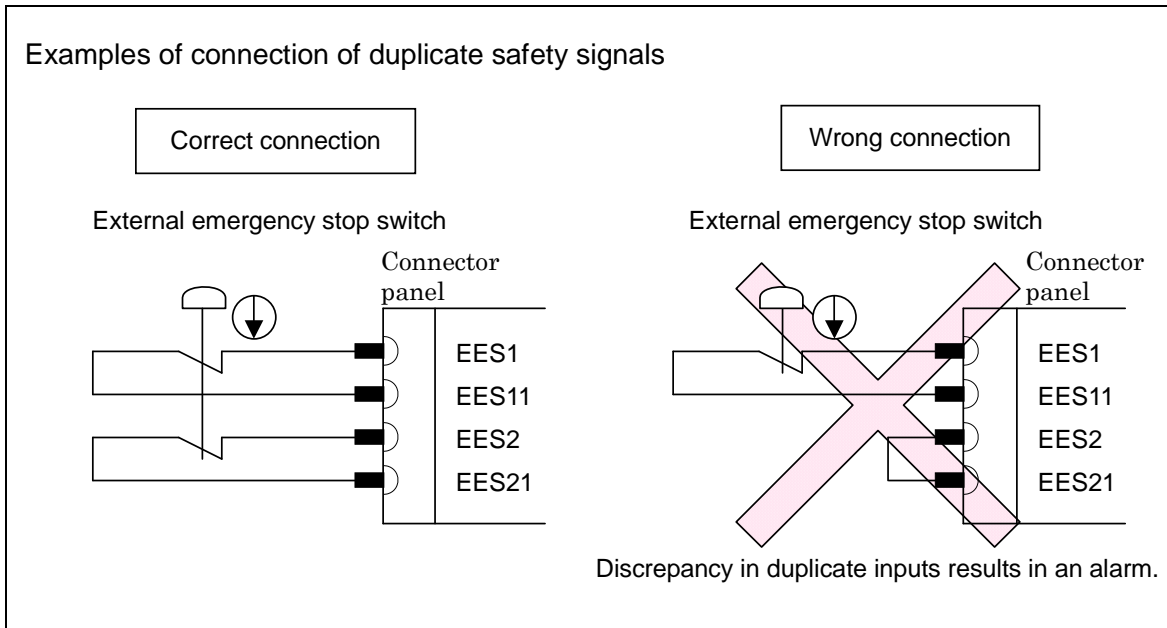


External emergency stop input



Signal	Description	Current, voltage
EES1 EES11 EES2 EES21	Connect the contacts of the external emergency stop switch to these terminals. When a contact is open, the servo power supply is turned off, and the robot is immediately placed in the emergency stop state. When using the contacts of a relay or contactor instead of the switch, connect a spark killer to the coil of the relay or contactor, to suppress noise. When these terminals are not used, jumper them.	Open and close of 24VDC 0.1A (Note 1)
EAS1 EAS11 EAS2 EAS21	These signals are used to stop the robot safely when the safety fence gate is opened during operation in the AUTO mode. When a contact is open, the robot decelerates then stops, and the servo power supply is turned off. In the T1 or T2 mode and the DEADMAN switch is held correct position, the robot can be operated even when the safety fence gate is open. When using the contacts of a relay or contactor instead of the switch, connect a spark killer to the coil of the relay or contactor, to suppress noise. When these terminals are not used, jumper them.	Open and close of 24VDC 0.1A (Note 1)

NOTE
 1 Use a contact which minimum load is 5 mA less.



Input timing of duplicate safety signals

Duplicate inputs are used for signals such as the external emergency stop signal, safety fence signal, and servo off signal so that a response is made even when a single failure occurs. The statuses of these duplicate input signals must always be changed at the same timing according to the timing specifications provided in this section. The robot control unit always checks that the statuses of the duplicate inputs are the same, and if the control unit finds a discrepancy, it issues an alarm. If the timing specifications are not satisfied, an alarm may be issued because of a signal discrepancy.

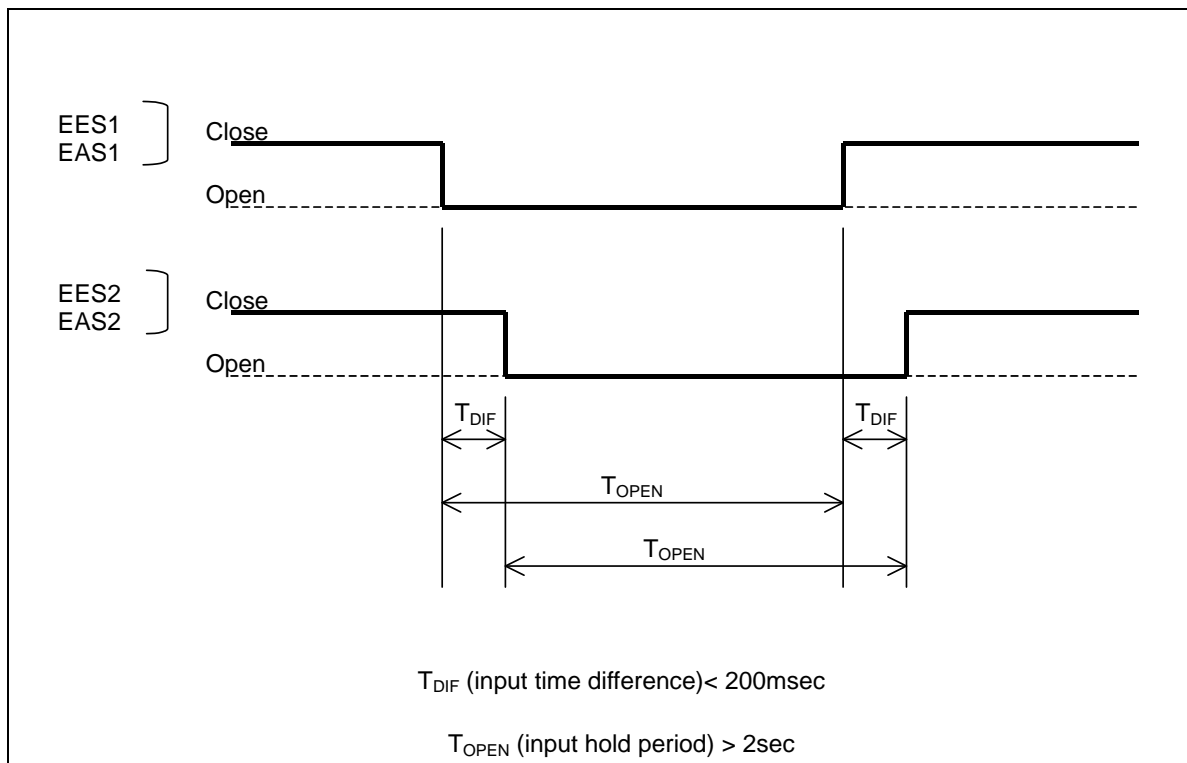


Fig.3.3.4 (c) Input timing of duplicate safety signals

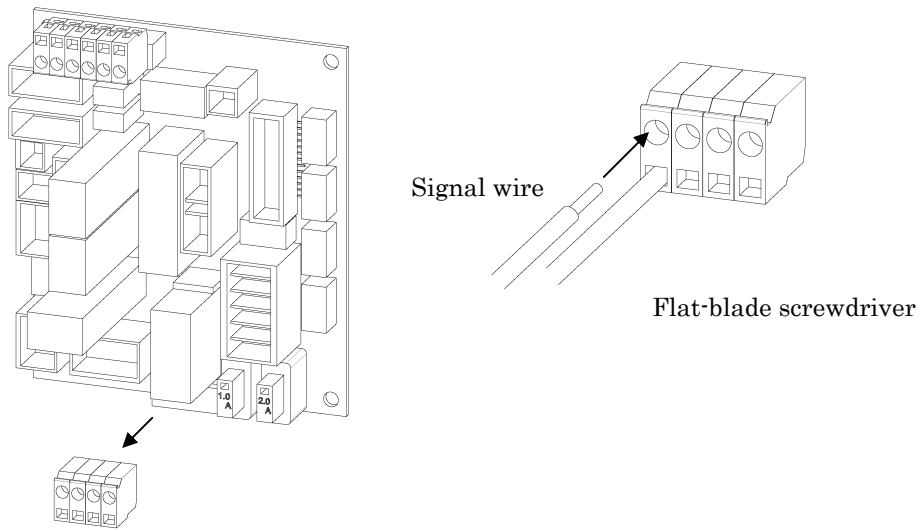
Connecting external on/off and external emergency stop signal input/output wires

	FANUC's specification	Manufacturer's specification (WAGO)	Remark
8-pole terminal block (TBOP7)	A63L-0001-0783#308	231-308/026-000	External emergency stop
12-pole terminal block (TBOP6)	A63L-0001-0783#312	231-312/026-000	External emergency stop
Jumper pin	A63L-0001-0783#902	231-902	
Operation lever	A63L-0001-0783#131-M	231-131	2 pieces of 231-131 and operation manual are included in FANUC's specification

1. Detach the plug connector block from the panel board.
2. Insert the tip of a flat-blade screwdriver into the manipulation slot and push down its handle.
3. Insert the end of the signal wire into the wire slot.
4. Pull out the screwdriver.
5. Attach the plug connector block to the panel board.

Do not insert a wire into the wire hole of a plug connector or pull it out with the plug connector block mounted on the panel board; otherwise, the panel board may be damaged.

FANUC recommends the lever (A05B-2400-K030) for connecting the signal wire to the plug connector block instead of Flat-blade screwdriver.



Wiring

(1) Pull down the lever.

(2) Push in the conductor while holding the lever.

(3) Set the lever free.
* In addition, pull the conductor softly to check the clamping.

* Don't pull strongly.

Replace the lever

(1) Pull off the lever. Be careful not to lose the lever.

(2) Hook the lever to the rectangle hole.

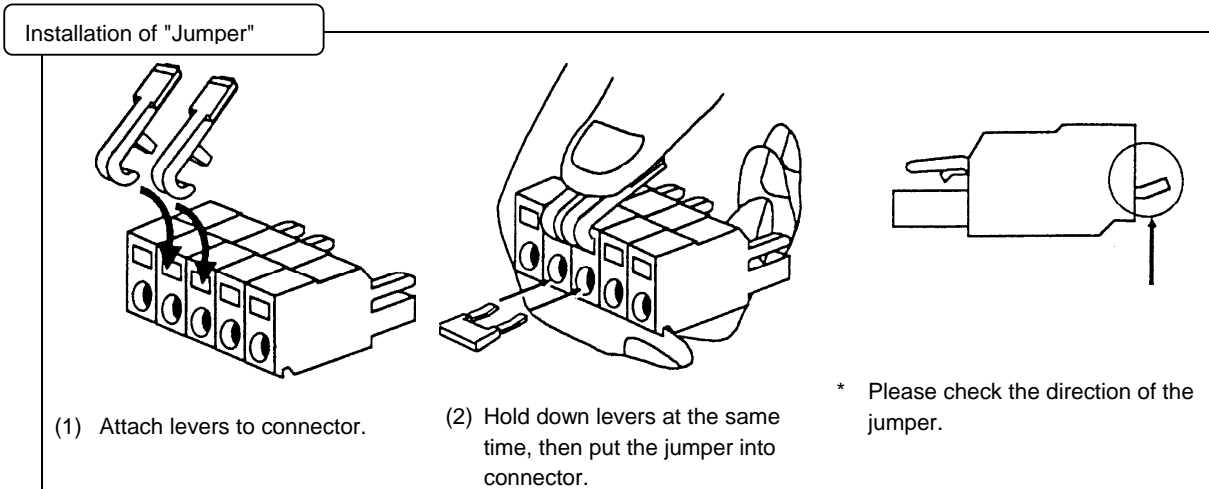
(3) Push down the lever until click in.

Fit to header

(1) Push in the connector to header.

(2) Please check if the latch is hooked to header.

* Be careful to fit the shape of each other.



3.3.5 Connecting the Auxiliary Axis Brake (CRR65 A/B)

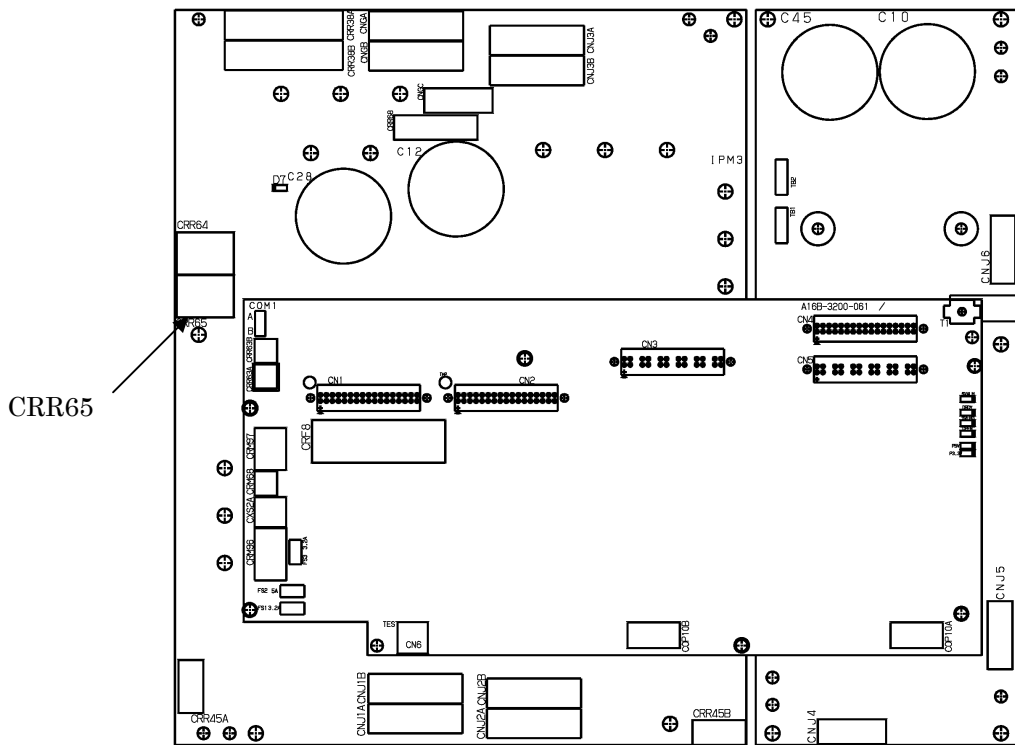


Fig.3.3.5 6-axis servo amplifier

Table 3.3.5 CRR65 A/B connector manufactured by Tyco Electronics AMP k.k.

CRR65 A/B			
A1	BKA1	B1	BKA2
A2		B2	
A3	COMMON	B3	COMMON

Specification:

Rece-housing 1-178129-6 : A63L-0001-0460#062KMXX

Rece-contact 175218-2 : A63L-0001-0456#ASL

3.3.6 Connecting the Auxiliary Axis Over Travel (CRM68)

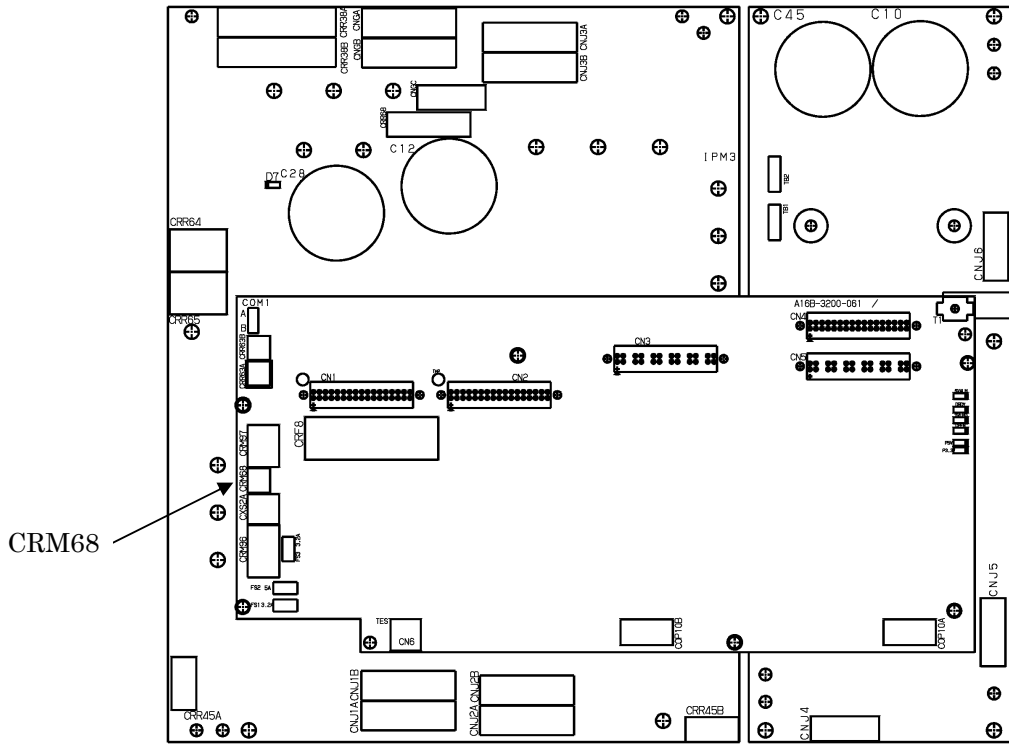


Fig.3.3.6 6-axis servo amplifier

Table 3.3.6 CRM68 connector manufactured by Tyco Electronics AMP k.k.

CRM68	
A1	AUXOT1
A2	AUXOT2
A3	

Specification:

Rece-housing 1-1318120-3 : A63L-0001-0812#R03SX

Rece-contact 1318107-1 : A63L-0001-0812#CRM

4 PERIPHERAL DEVICE AND END EFFECTOR INTERFACES

Table 4 lists the peripheral device interfaces of the R-30iA Mate. Fig. 4 shows a peripheral device cable routing diagram.

Table 4 Peripheral device interface types

No.	Name	Drawing number	Peripheral device interface				Remarks
			CRMA15		CRMA16		
			DI	DO	DI	DO	
1a	Main board A	A20B-8200-0470	20	8	8	16	Standard
1b	Main board B	A20B-8200-0471	20	8	8	16	With Vision I/F

No.	Name	Drawing number	Peripheral device interface				Remarks
			CRMA52A		CRMA52B		
			DI	DO	DI	DO	
2	Process I/O board MA	A20B-2004-0380	10	8	10	8	Option

No.	Name	Drawing number	Peripheral device interface				Remarks
			CRW11				
			WI	WO	D/A	A/D	
3	Process I/O board MB	A20B-2101-0730	5	4	2	0	Option

No.	Name	Drawing number	Remarks
4	Connector converter board	A20B-2004-0410	This option board converts peripheral device interfaces CRMA15 and CRMA16 of the main board to the MR connector manufactured by Honda Tsushin Kogyo Co., LTD.

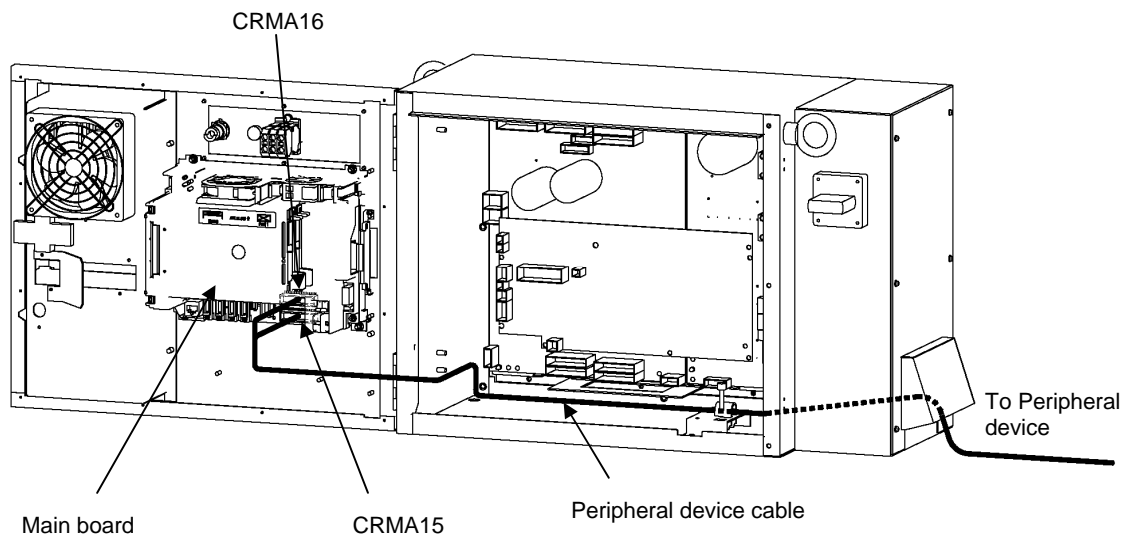


Fig.4 (a) Connecting the peripheral device cable

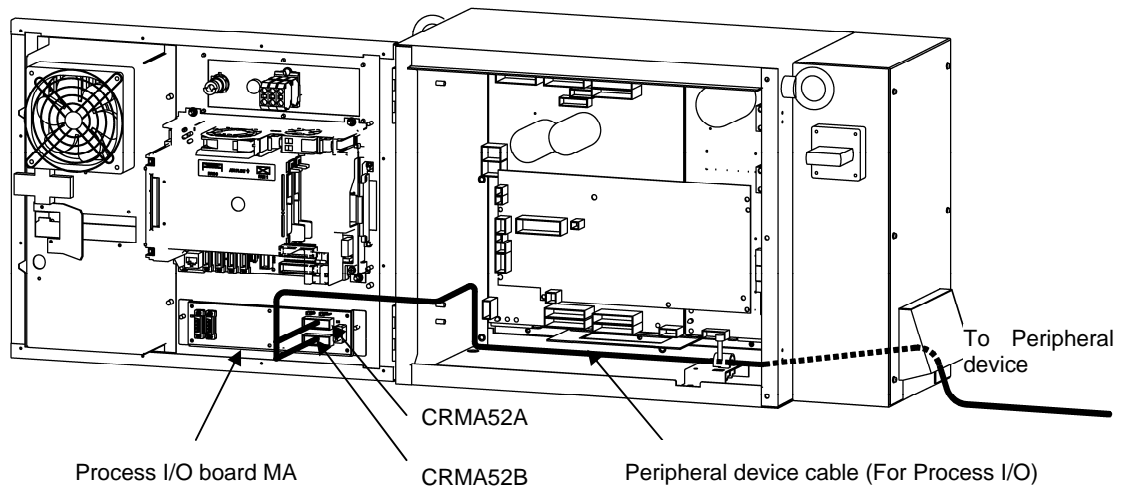


Fig. 4 (b) Connecting the peripheral device cable (Process I/O board MA)

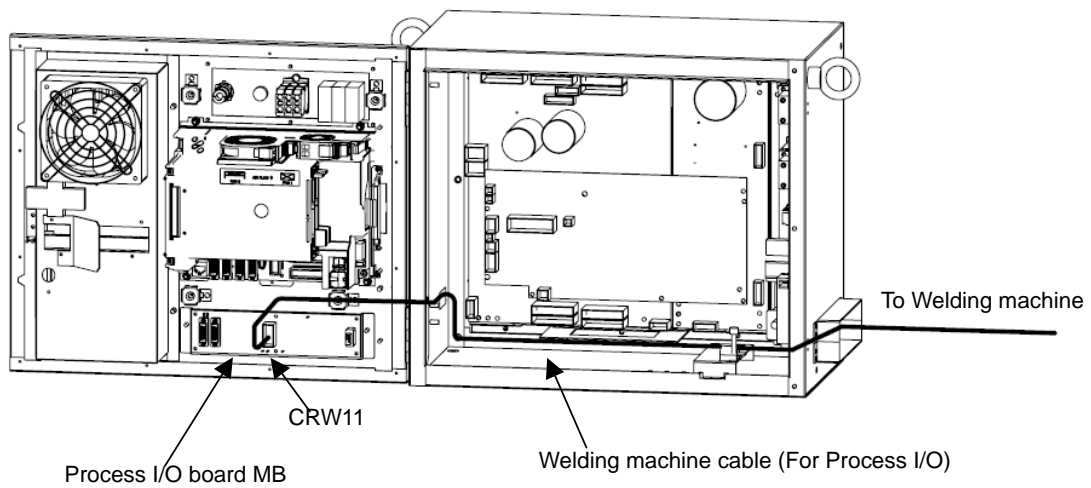


Fig.4 (c) Connecting the welding machine cable (Process I/O board MB)

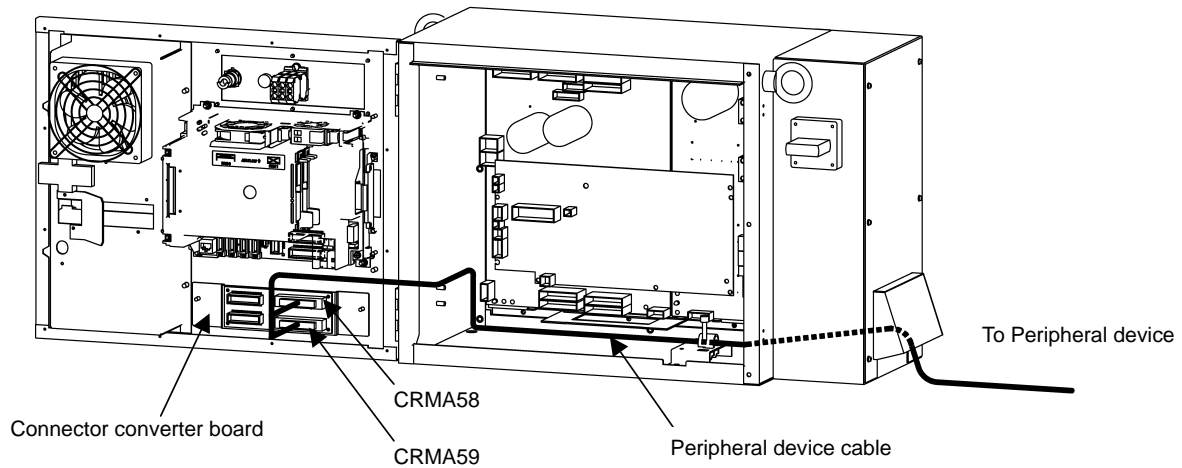


Fig.4 (d) Connecting the peripheral device cable (Connector converter board)

4.1 PERIPHERAL DEVICE INTERFACE BLOCK DIAGRAM

Following are a block diagram of the peripheral device interface and the specifications.

4.1.1 In Case of Main Board (CRMA15, CRMA16)

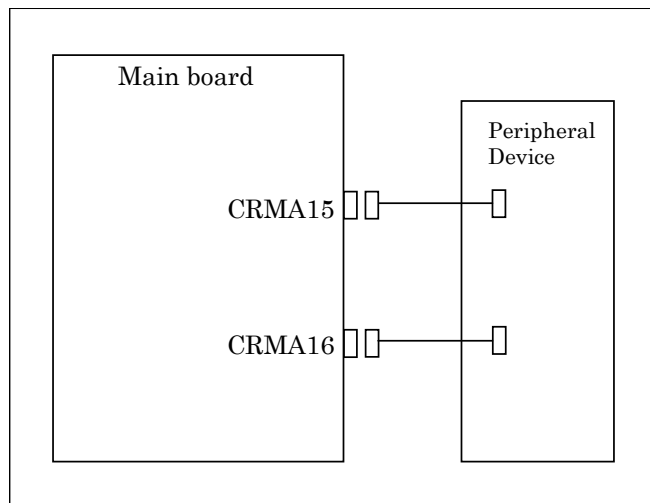
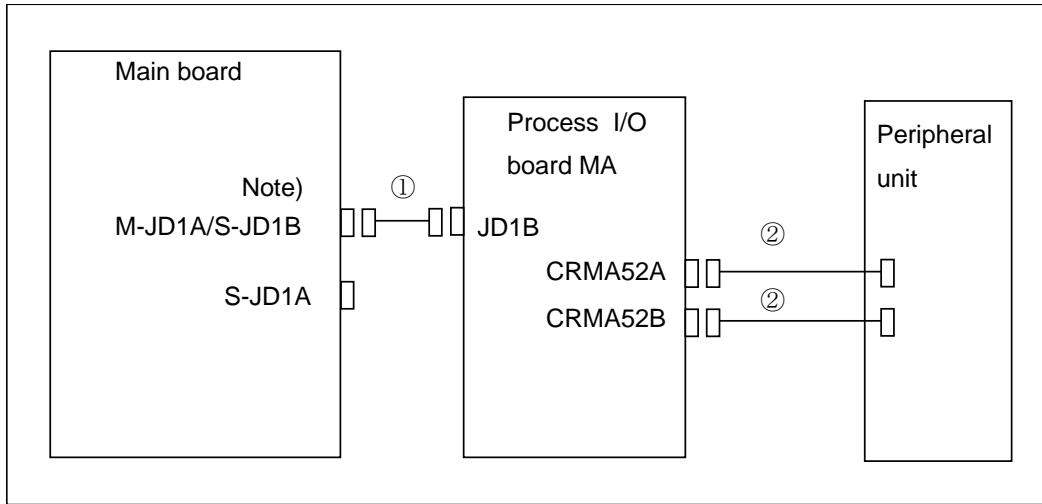


Fig.4.1.1 Block diagram of connecting peripheral device cable

Name	Drawing number	Remarks
Peripheral device connection cable (For main board)	A05B-2550-J100	Length: 10m (CRMA15) Length: 10m (CRMA16)
	A05B-2550-J101	Length: 20m (CRMA15) Length: 20m (CRMA16)

4.1.2 In the Case of the Process I/O Board MA

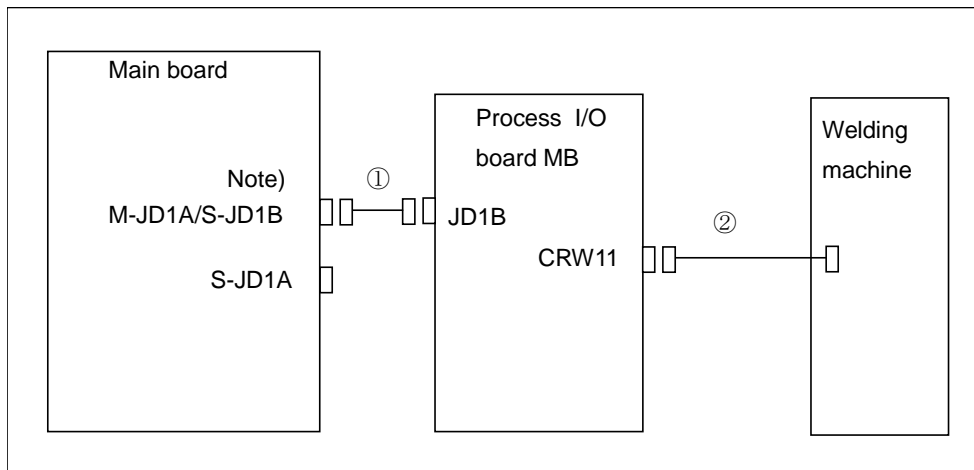


(Note) The connection depends on whether the R-30iA Mate is the I/O link master or an I/O link slave. For details, see Section 3.2.1.

Fig.4.1.2 Block diagram of the process I/O MA

Component	Drawing number	Remark
<1> I/O link cable	-	Included in the process I/O board MA
<2> Peripheral device cable (For process I/O MA)	A05B-2550-J220	Connection length 10m (one): CRMA52
	A05B-2550-J221	Connection length 20m (one): CRMA52

4.1.3 In the Case of the Process I/O Board MB

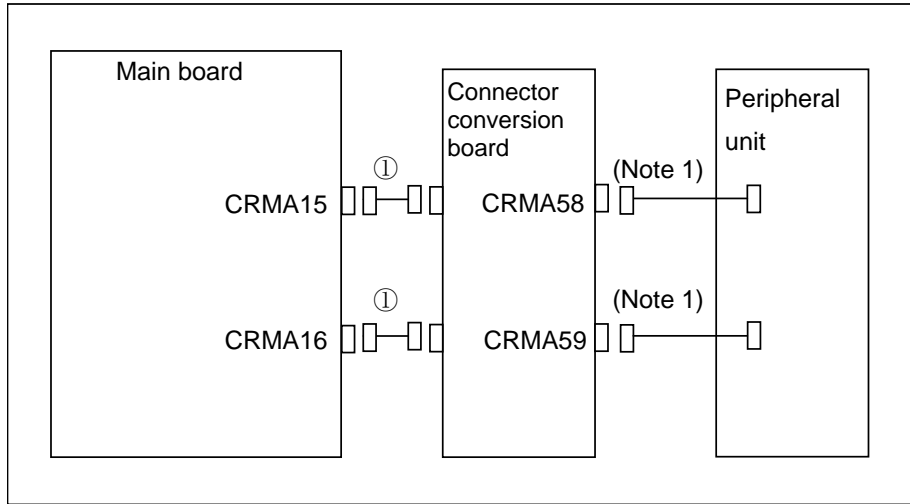


(Note) The connection depends on whether the R-30iA Mate is the I/O link master or an I/O link slave. For details, see Section 3.2.1.

Fig.4.1.3 Block diagram of the process I/O MB

Component	Drawing number	Remark
<1> I/O link cable	-	Included in the process I/O board MB
<2> Welding machine connection cable (For process I/O MB) (FANUC interface/elbow type)	A05B-2552-J204	Connection length 7m (one): CRW11

4.1.4 In the Case of the Connector Conversion Board



NOTE
This component is not provided by FANUC. The customer needs to obtain it.
For details on the connection method, see "Connection between the peripheral devices and the control unit".

Fig.4.1.4 Connection diagram of the connector conversion board

Component	Drawing number	Remark
<1> Connection cable	-	Included in the I/O connector conversion board.

4.2 I/O SIGNALS OF MAIN BOARD

There are 28 data inputs (DI) and 24 data outputs (DO) on main board.
Table 4.2 shows I/O signals of main board.

Table 4.2 I/O Signals of main board

Connector number	Signal name	Description	Remarks
(DI signals)			
CRMA15-A5	DI101	Peripheral device status	General signal
CRMA15-B5	DI102		
CRMA15-A6	DI103		
CRMA15-B6	DI104		
CRMA15-A7	DI105		
CRMA15-B7	DI106		
CRMA15-A8	DI107		
CRMA15-B8	DI108		

4. PERIPHERAL DEVICE AND
END EFFECTOR INTERFACES

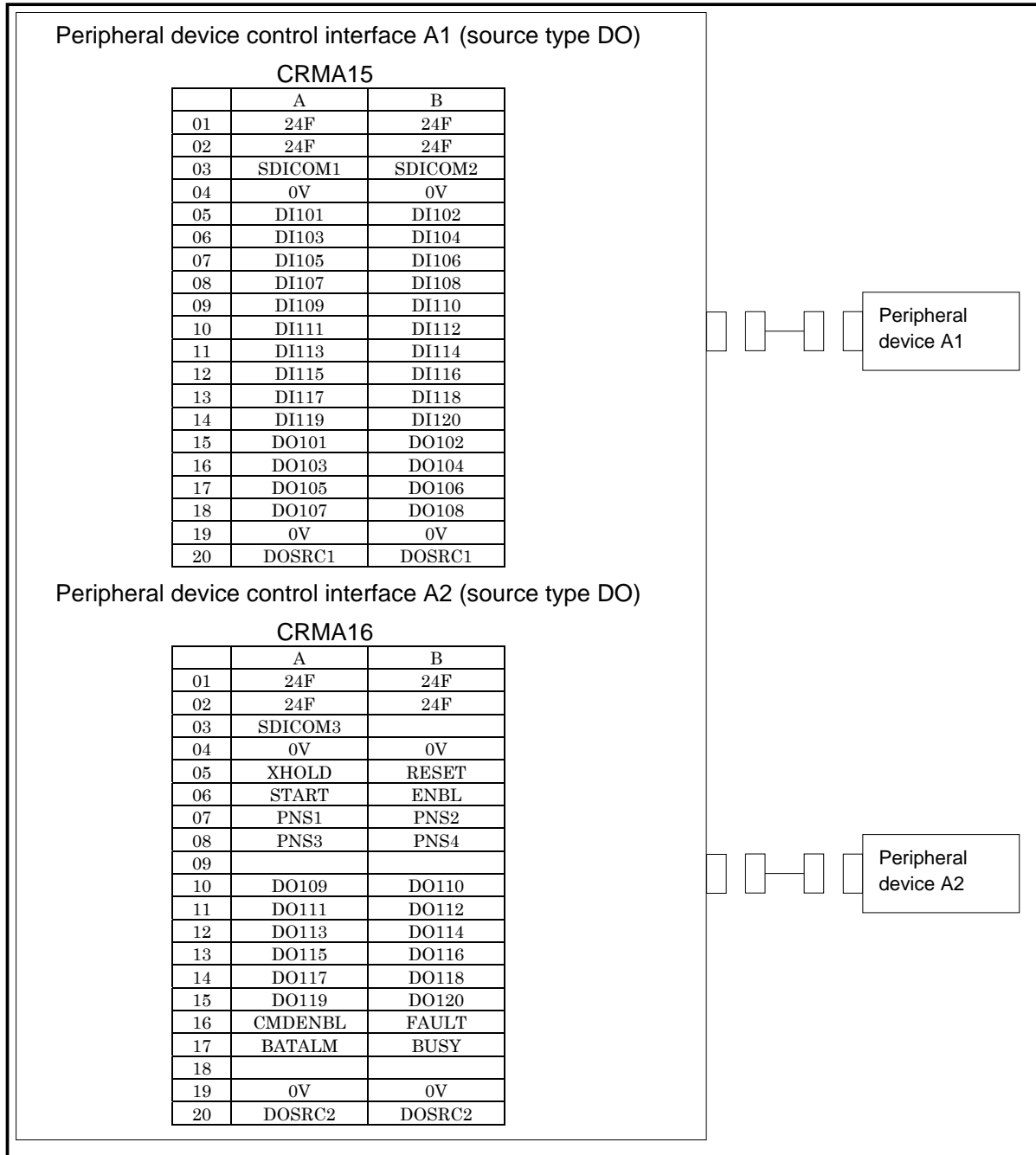
CONNECTIONS

B-82725EN-1/07

Connector number	Signal name	Description	Remarks		
CRMA15-A9	DI109	Peripheral device status	General signal		
CRMA15-B9	DI110				
CRMA15-A10	DI111				
CRMA15-B10	DI112				
CRMA15-A11	DI113				
CRMA15-B11	DI114				
CRMA15-A12	DI115				
CRMA15-B12	DI116				
CRMA15-A13	DI117				
CRMA15-B13	DI118				
CRMA15-A14	DI119				
CRMA15-B14	DI120				
CRMA16-A5	XHOLD			Temporary stop	
CRMA16-B5	FAULT RESET			External reset	
CRMA16-A6	START	Start			
CRMA16-B6	ENBL	Operation enabled			
CRMA16-A7	PNS1	Robot service request			
CRMA16-B7	PNS2				
CRMA16-A8	PNS3				
CRMA16-B8	PNS4				
(DO signals)					
CRMA15-A15	DO101	Peripheral device control signal	General signal		
CRMA15-B15	DO102				
CRMA15-A16	DO103				
CRMA15-B16	DO104				
CRMA15-A17	DO105				
CRMA15-B17	DO106				
CRMA15-A18	DO107				
CRMA15-B18	DO108				
CRMA16-A10	DO109				
CRMA16-B10	DO110				
CRMA16-A11	DO111				
CRMA16-B11	DO112				
CRMA16-A12	DO113				
CRMA16-B12	DO114				
CRMA16-A13	DO115				
CRMA16-B13	DO116				
CRMA16-A14	DO117				
CRMA16-B14	DO118				
CRMA16-A15	DO119				
CRMA16-B15	DO120				
CRMA16-A16	CMDENBL	During automatic operation			
CRMA16-B16	FAULT	Alarm			
CRMA16-A17	BATALM	Battery voltage drop			
CRMA16-B17	BUSY	During operation			

4.3 INTERFACE FOR PERIPHERAL DEVICES

4.3.1 Connection between the Main Board (CRMA15, CRMA16) and Peripheral Devices



SDICOM1~3 signal are common selection signal for SDI.

When +24F common is used, connect to 0V.

When 0V common is used, connect to +24F.

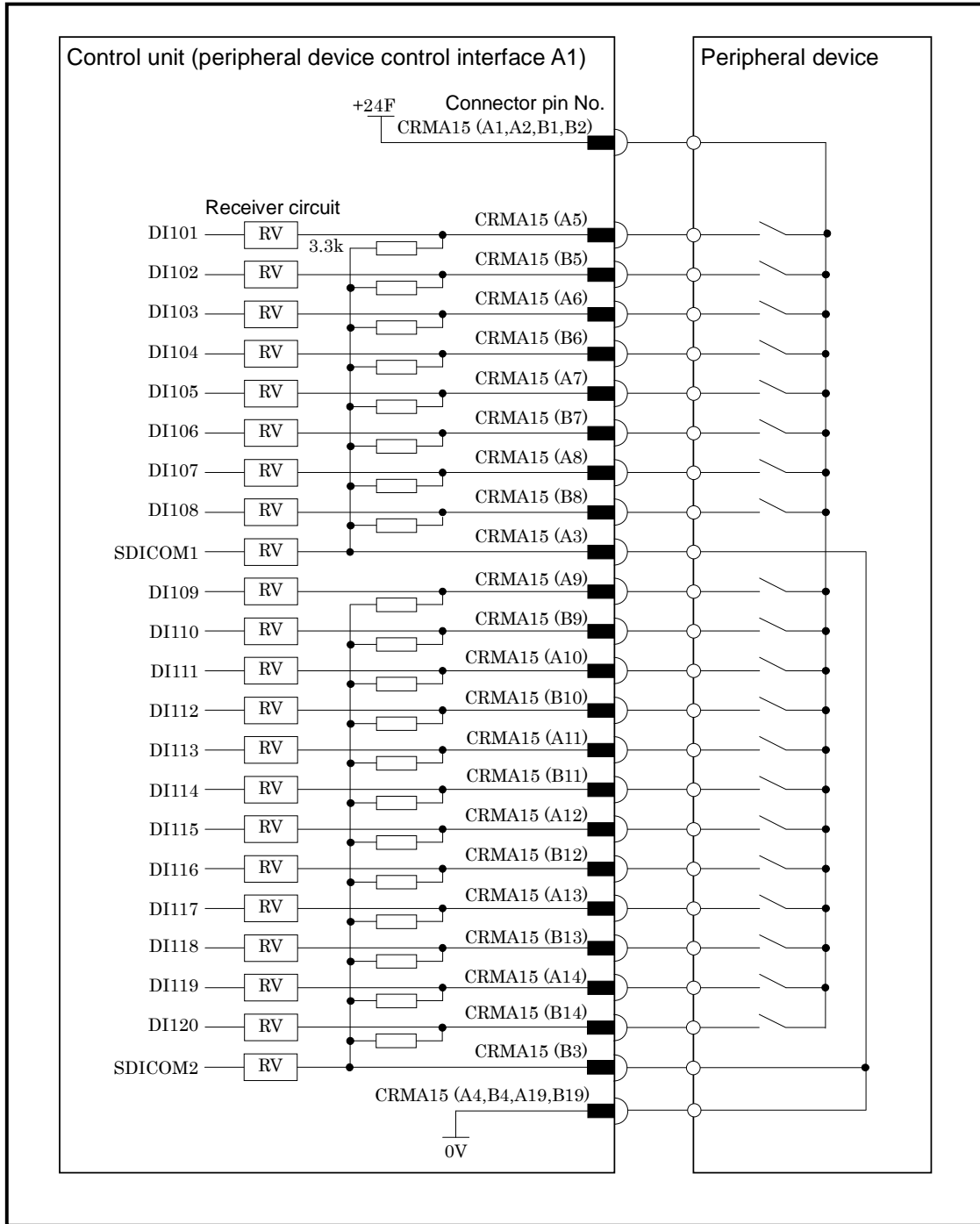
SDICOM1 → Selects a common for DI101~DI108.

SDICOM2 → Selects a common for DI109~DI120.

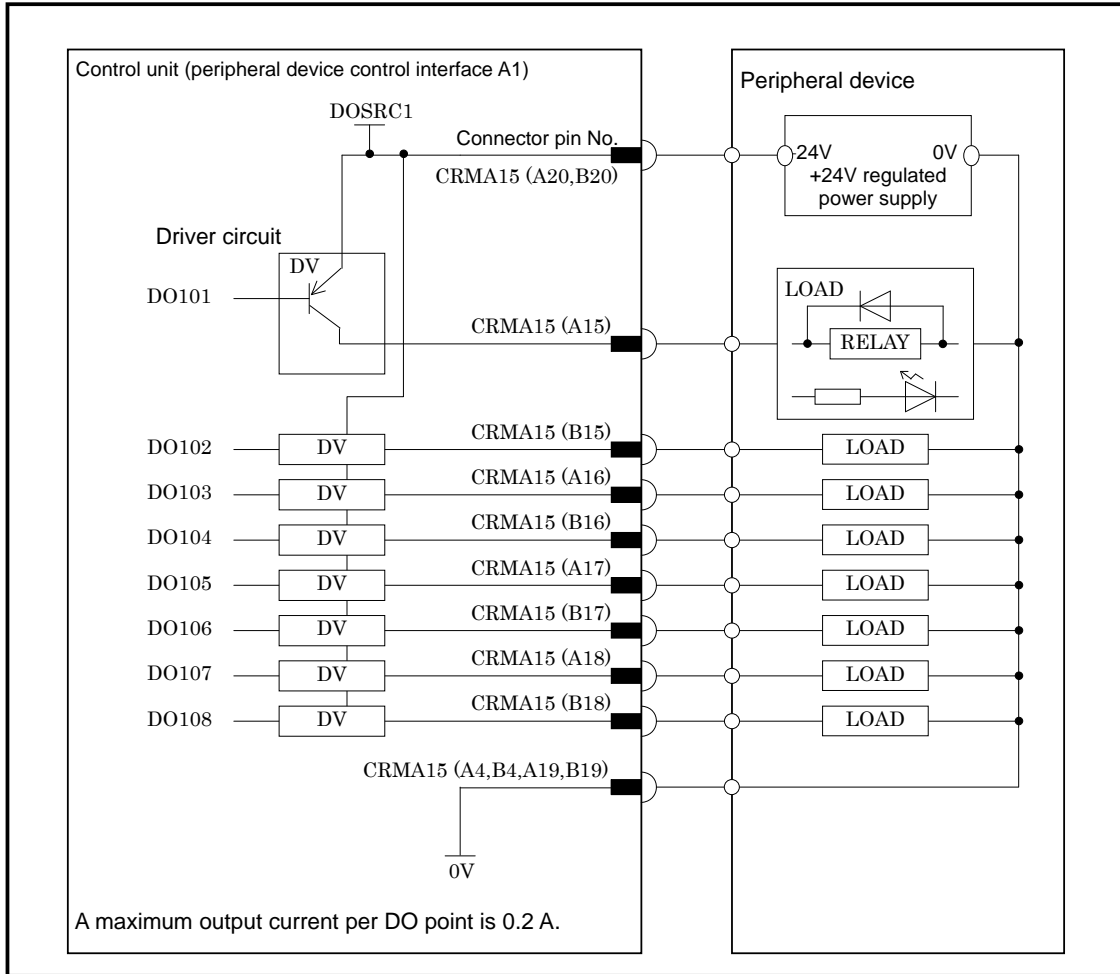
SDICOM3 → Selects a common for XHOLD、RESET、START、ENBL、PNS1~PNS4.

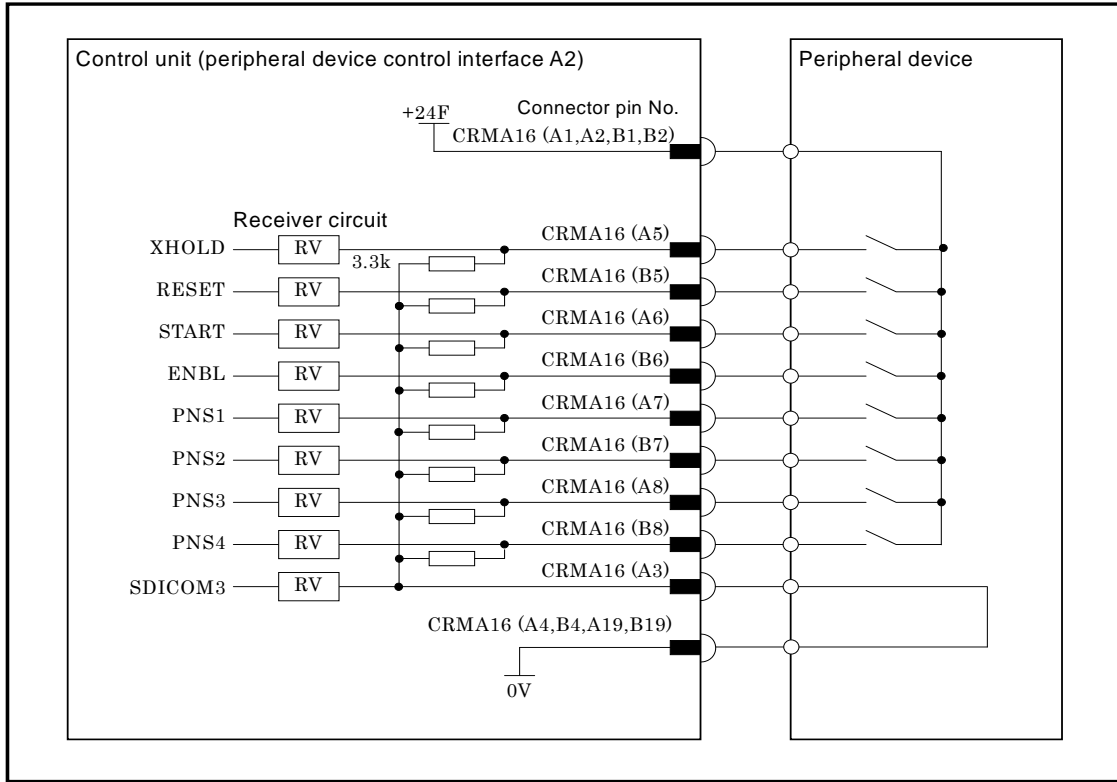
NOTE

- 1 The peripheral device connection cables are optional.
- 2 The DOSRC1 and DOSRC2 pins of the CRMA15 and CRMA16 are pins for supplying power to drivers. (None of these pins can be left open.)

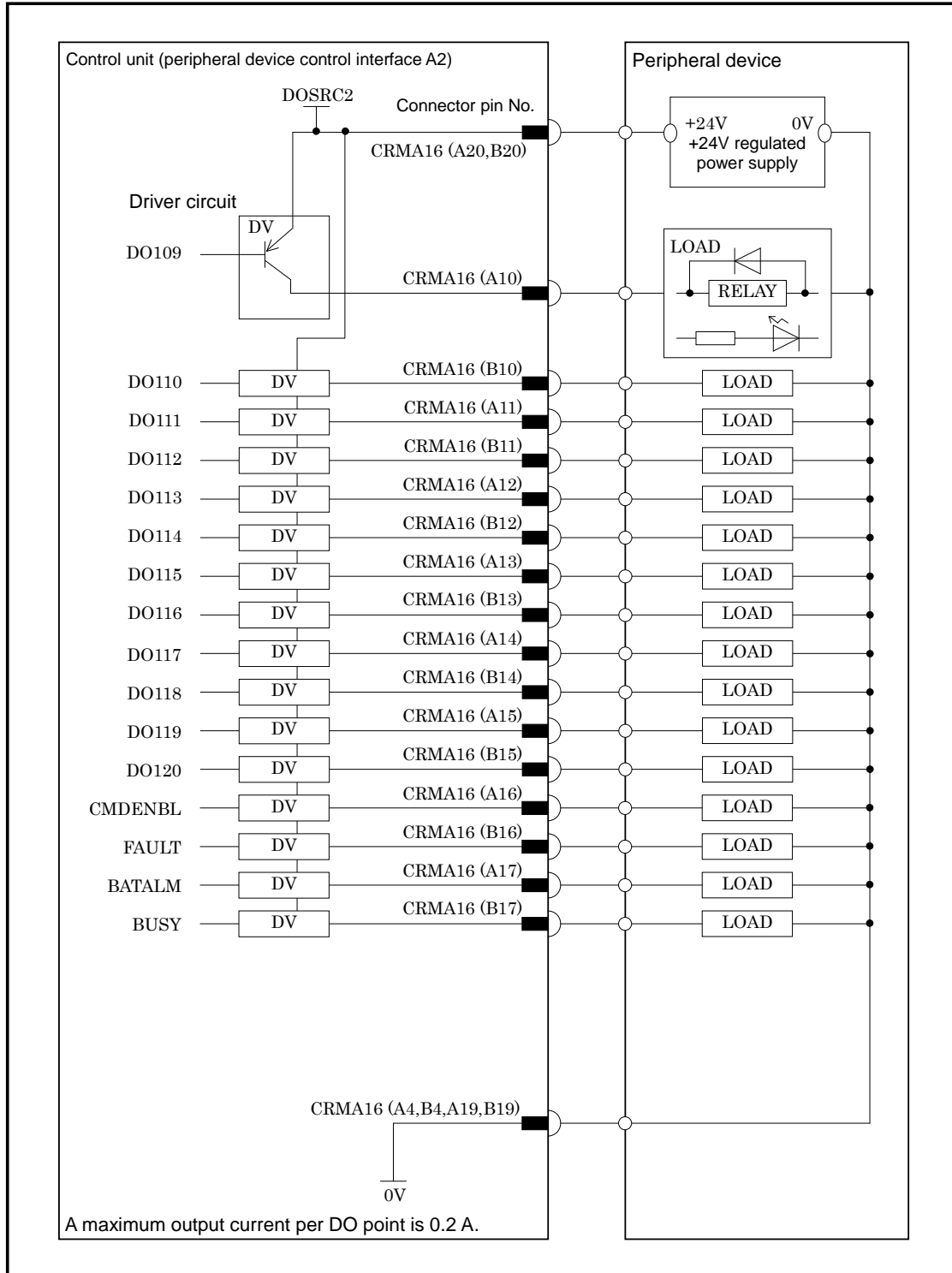


NOTE
In this diagram, common voltage of input devices is +24V.

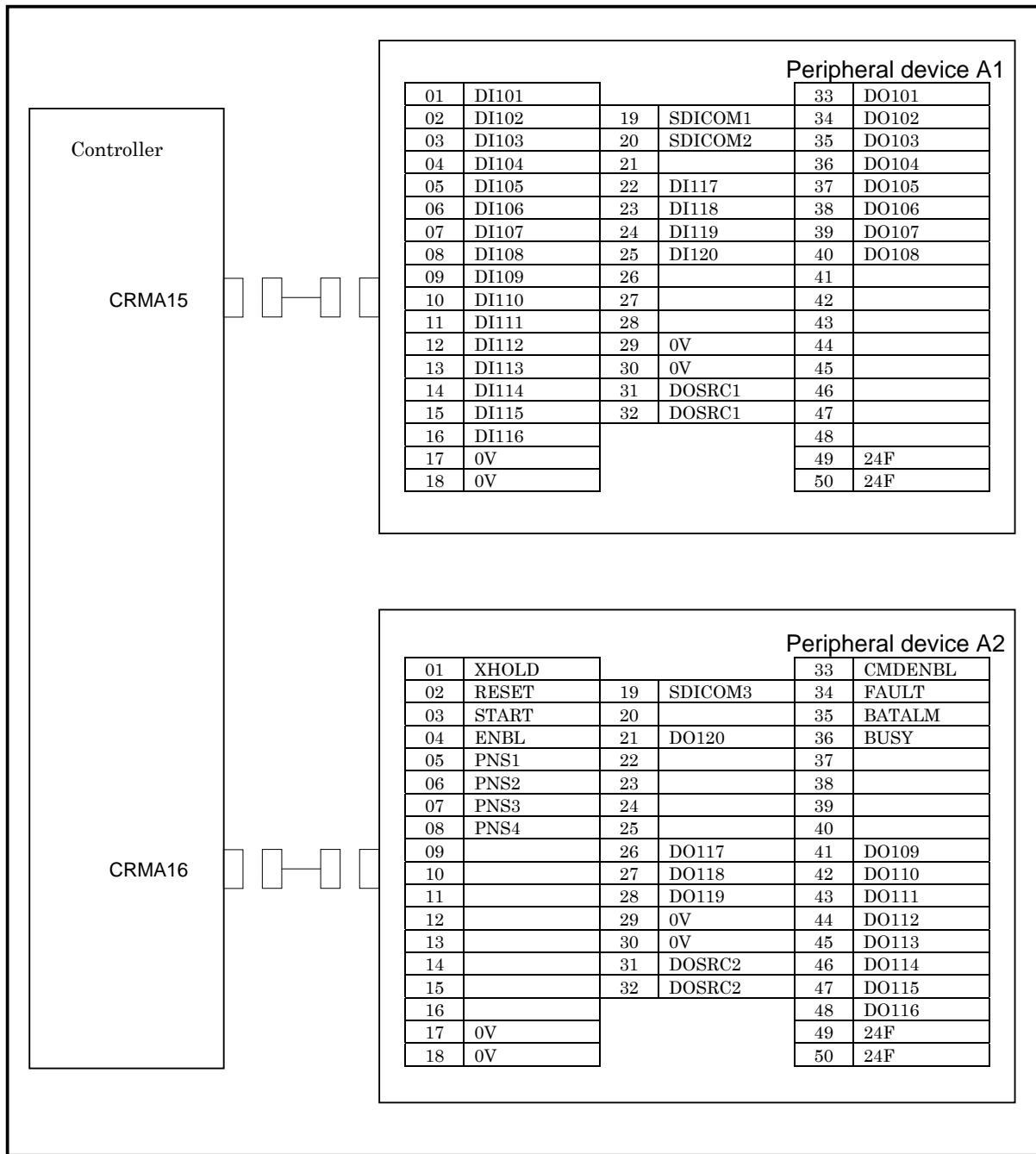




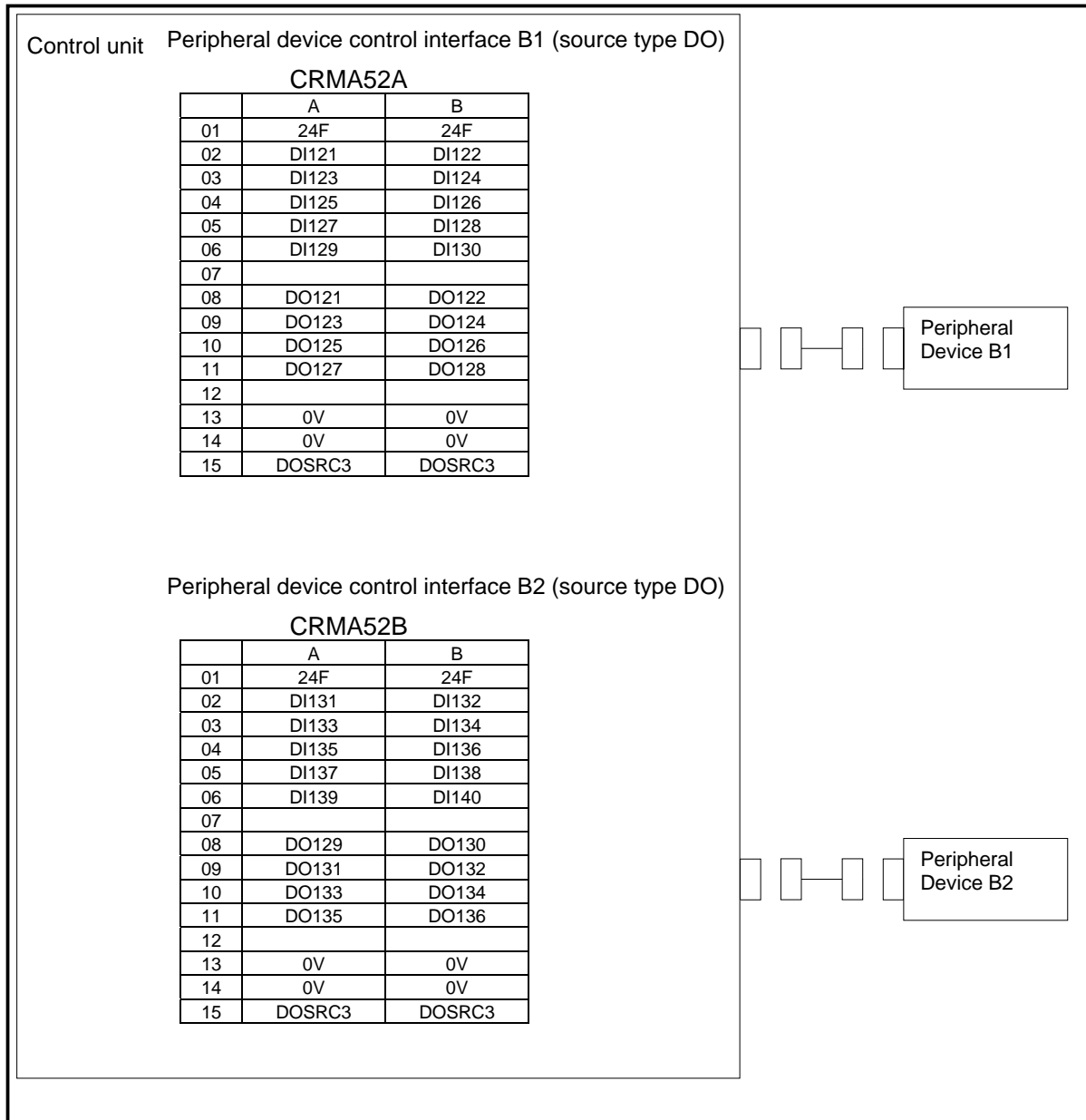
NOTE
In this diagram, common voltage of input devices is +24V.



The following shows the connector interface of the optional peripheral device cables on the peripheral device side.

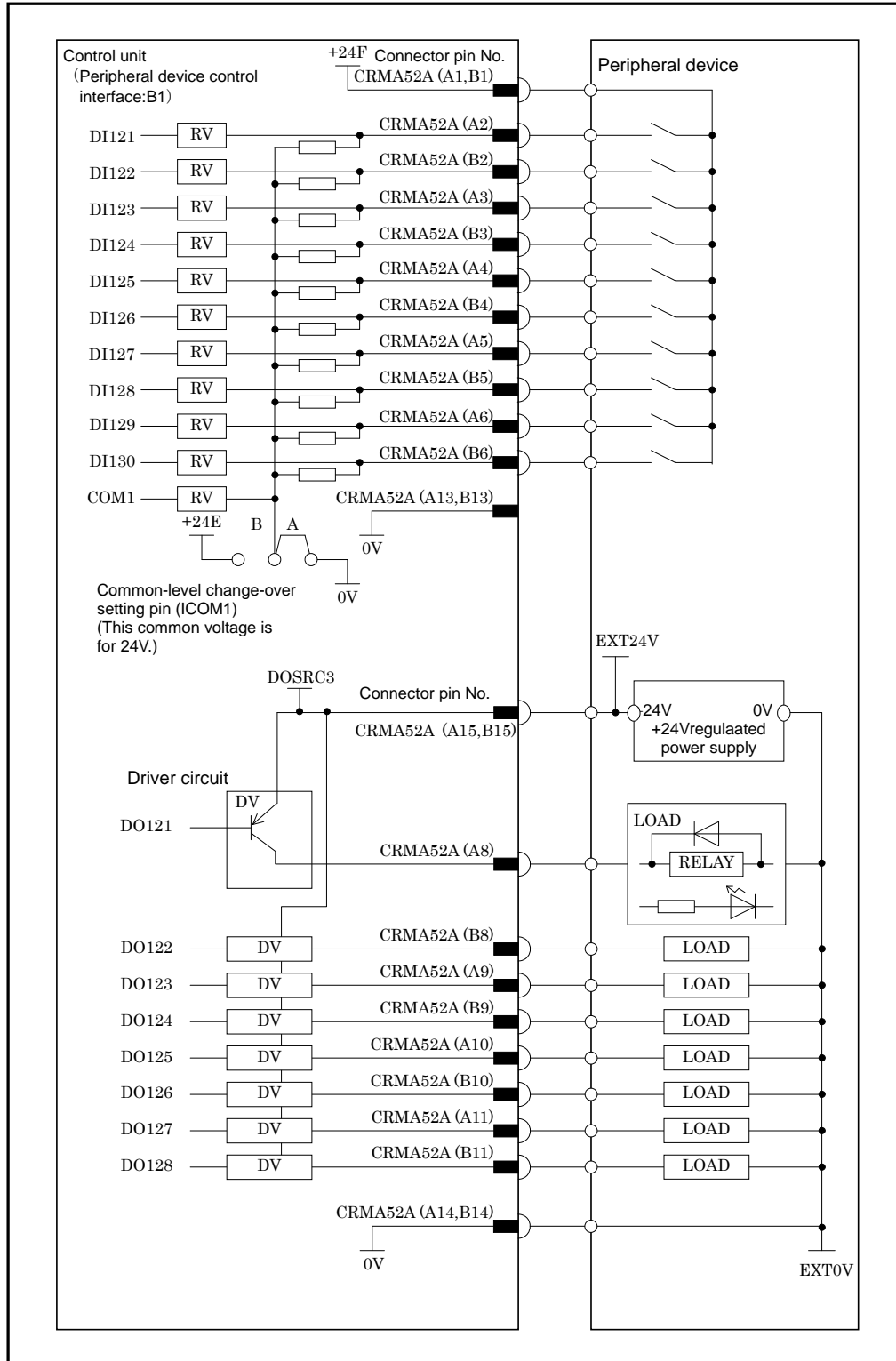


4.3.2 Connection between the Process I/O Board MA and Peripheral Devices

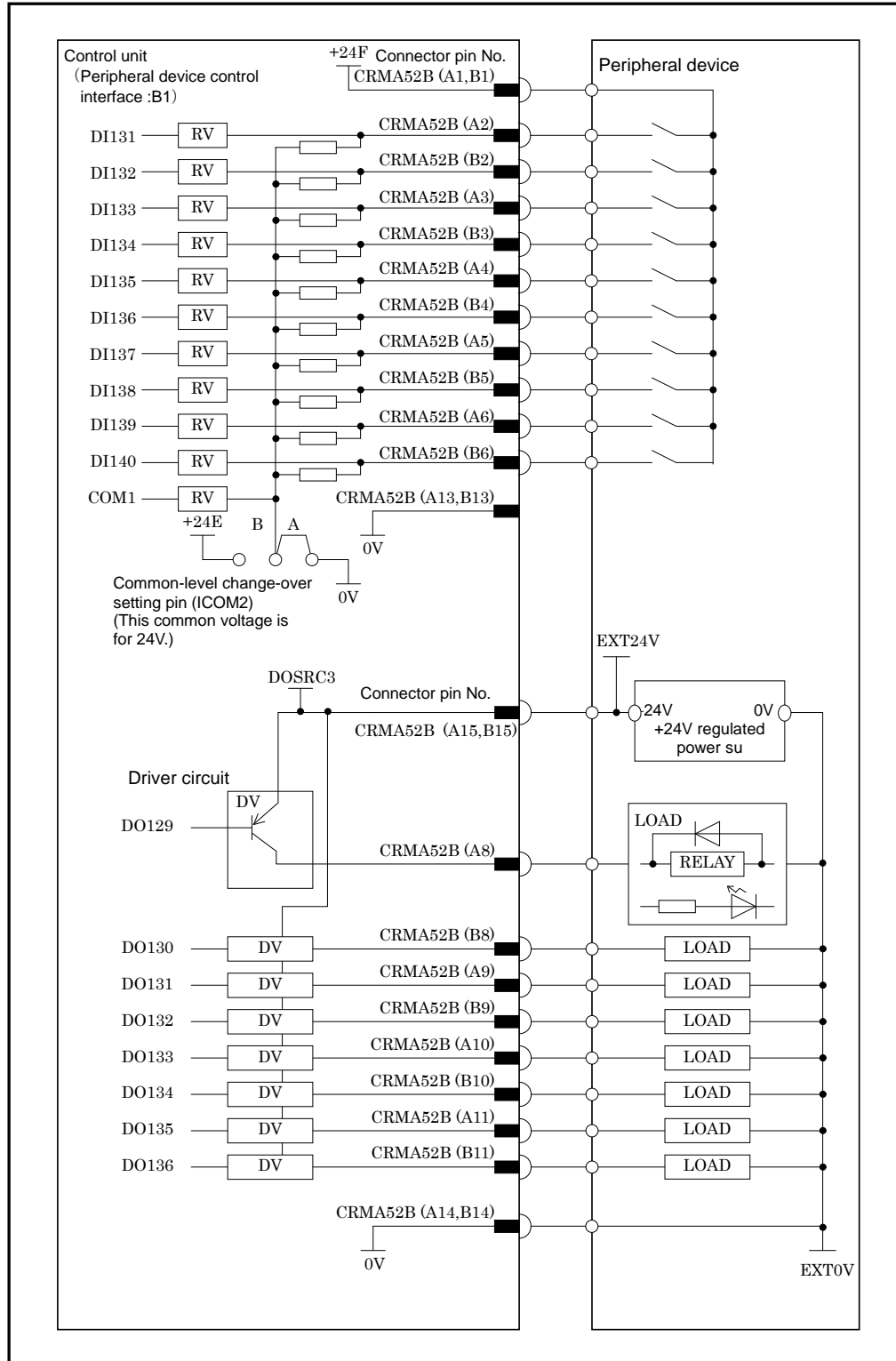


NOTE

- 1 The peripheral device connection cable is optional.
- 2 The DOSRC3 pin of CRMA52A and CRMA52B supply power to the drivers (connect all pins).

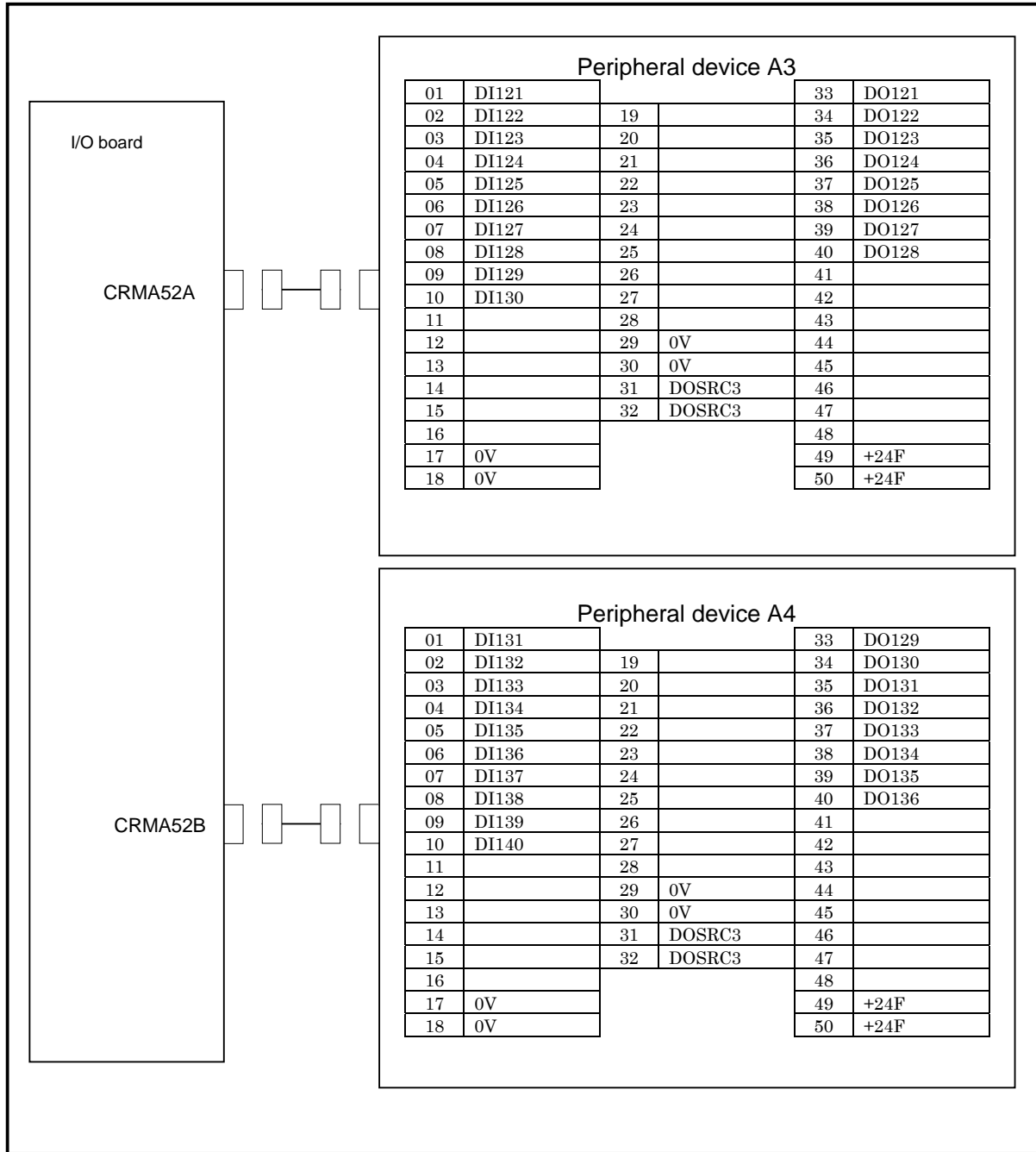


NOTE
In this diagram, common voltage of input device is 24V.



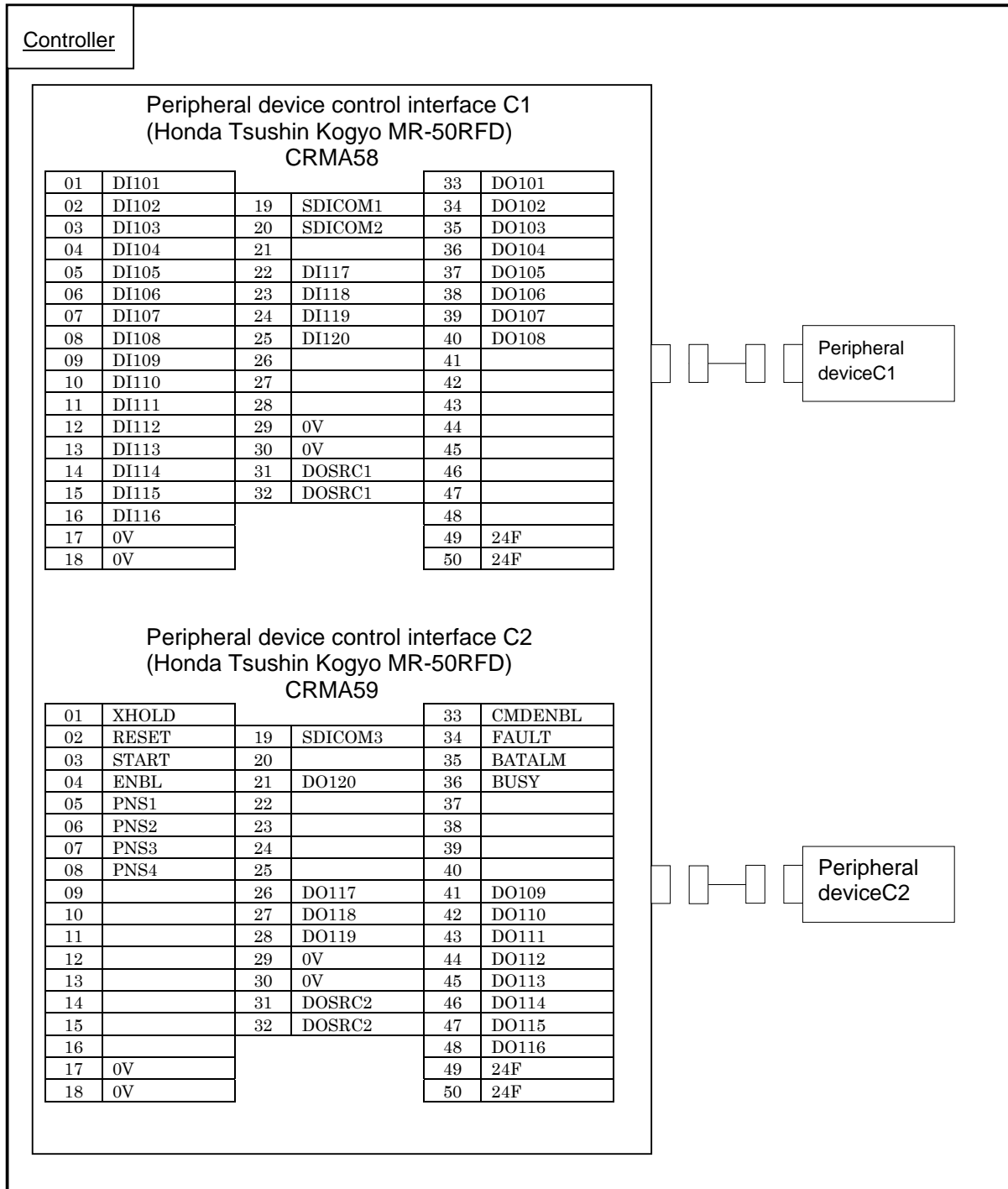
NOTE
In this diagram, common voltage of input device is +24V.

The following shows the connector interface of the optional peripheral device cables on the peripheral device side.

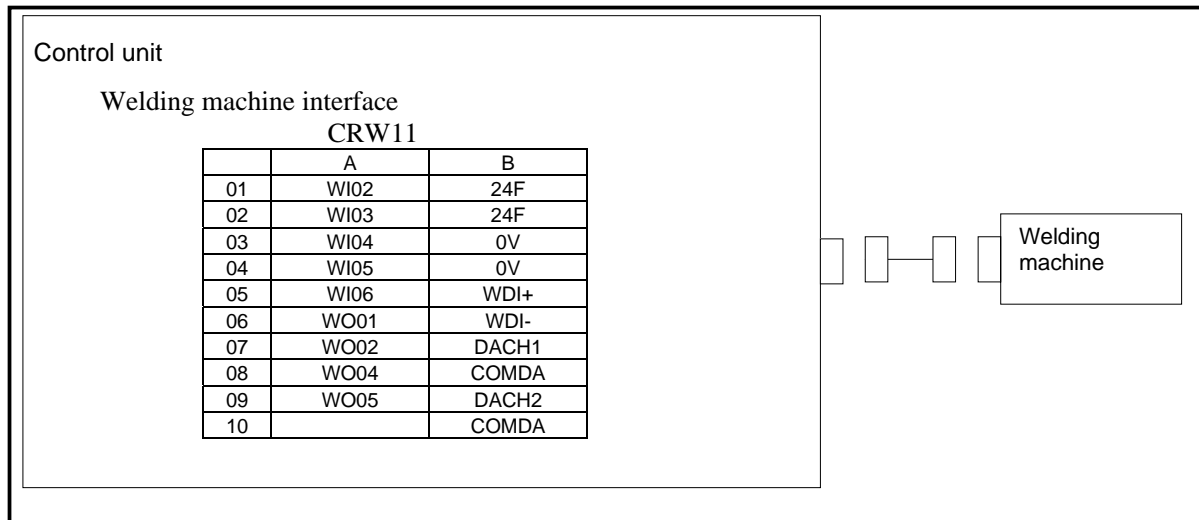


4.3.3 Connection between the Connector Conversion Board and Peripheral Devices

The connector interface of the optional connector conversion board is shown below. For electrical connection, see Section 4.3.1.

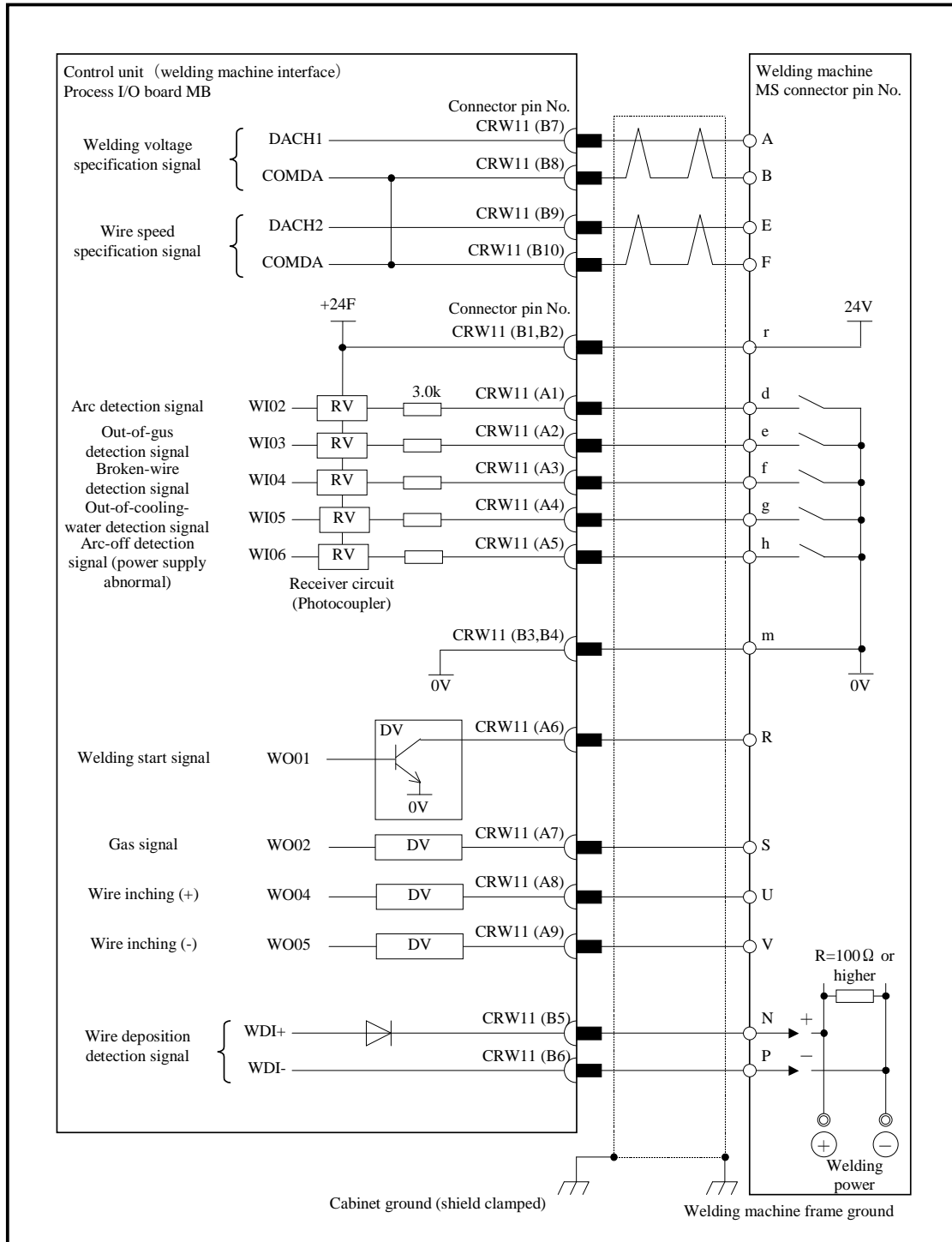


4.3.4 Connection between the Process I/O Board MB and Welding Machines



NOTE

- 1 The welding machine connection cable is optional.



**Pin-to-pin connection between CRW11 connector and welding machine connector (FANUC interface)
(Analog output, welding wire deposition detection, WI/WO connection)**

4.4 INTERFACE FOR END EFFECTOR

4.4.1 Connection between the LR Mate 200iC, ARC Mate 50iC and End Effector

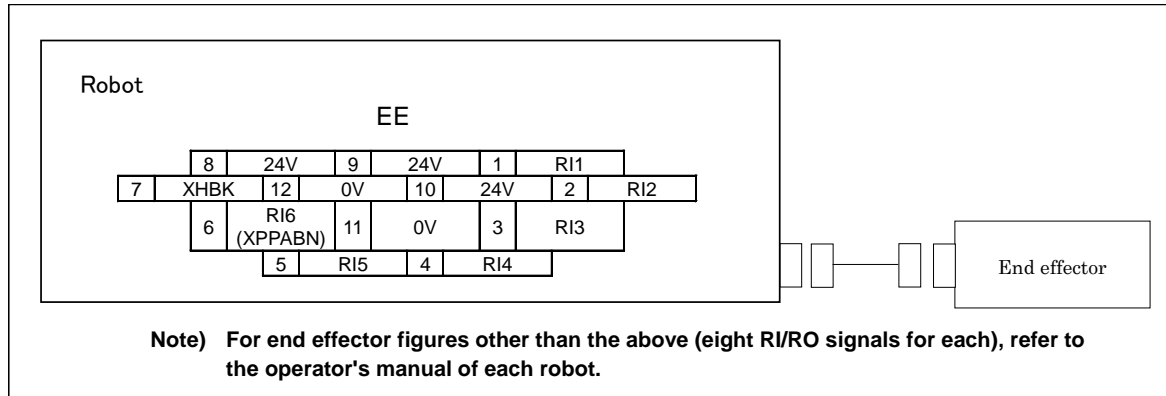
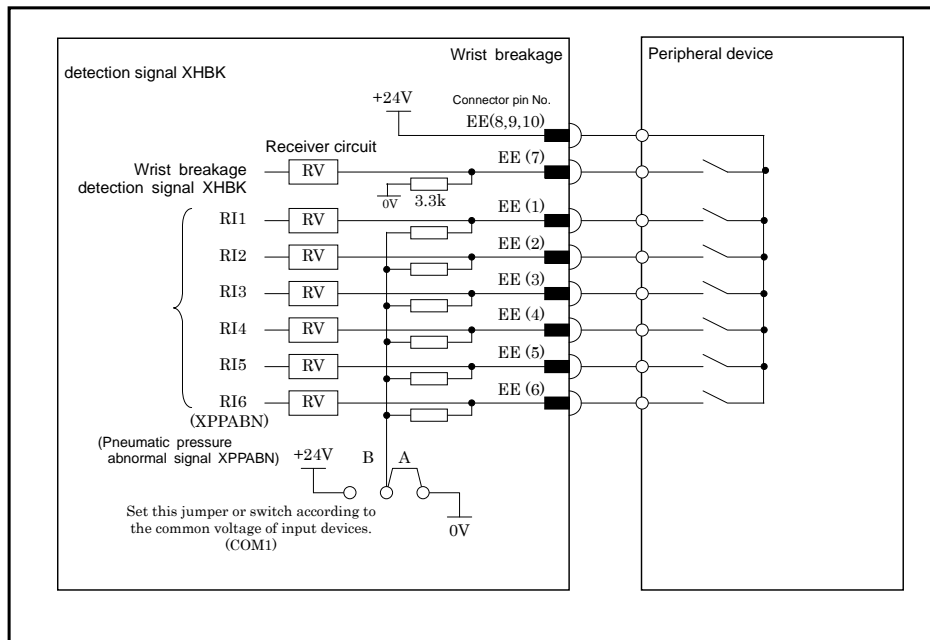


Fig.4.4.1 End effector interface

NOTE

RO1 to RO6 are used as the on/off signals of the solenoid valve option.
The RI and XHBK signals can be used for the end effector.
For RO, refer to the operator's manual of the mechanical unit.



NOTE

- 1 In this diagram, common voltage of input devices is +24V.
- 2 The common-level change-over setting pin or switch (COM1) is in the 6-axis servo amplifier.

4.4.2 Connection between the ARC Mate 100iC/M-10iA, ARC Mate 120iC/M-20iA, ARC Mate 0iA and End Effector

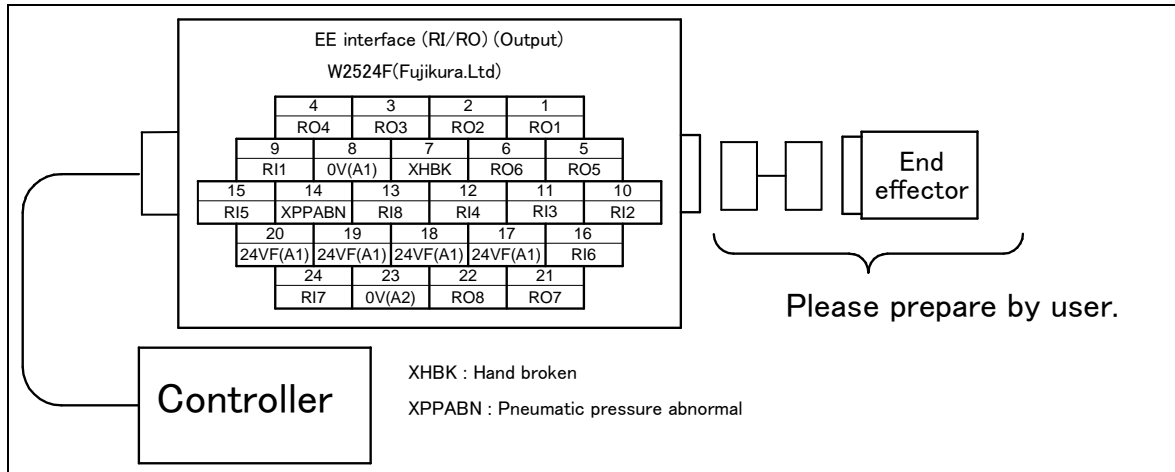
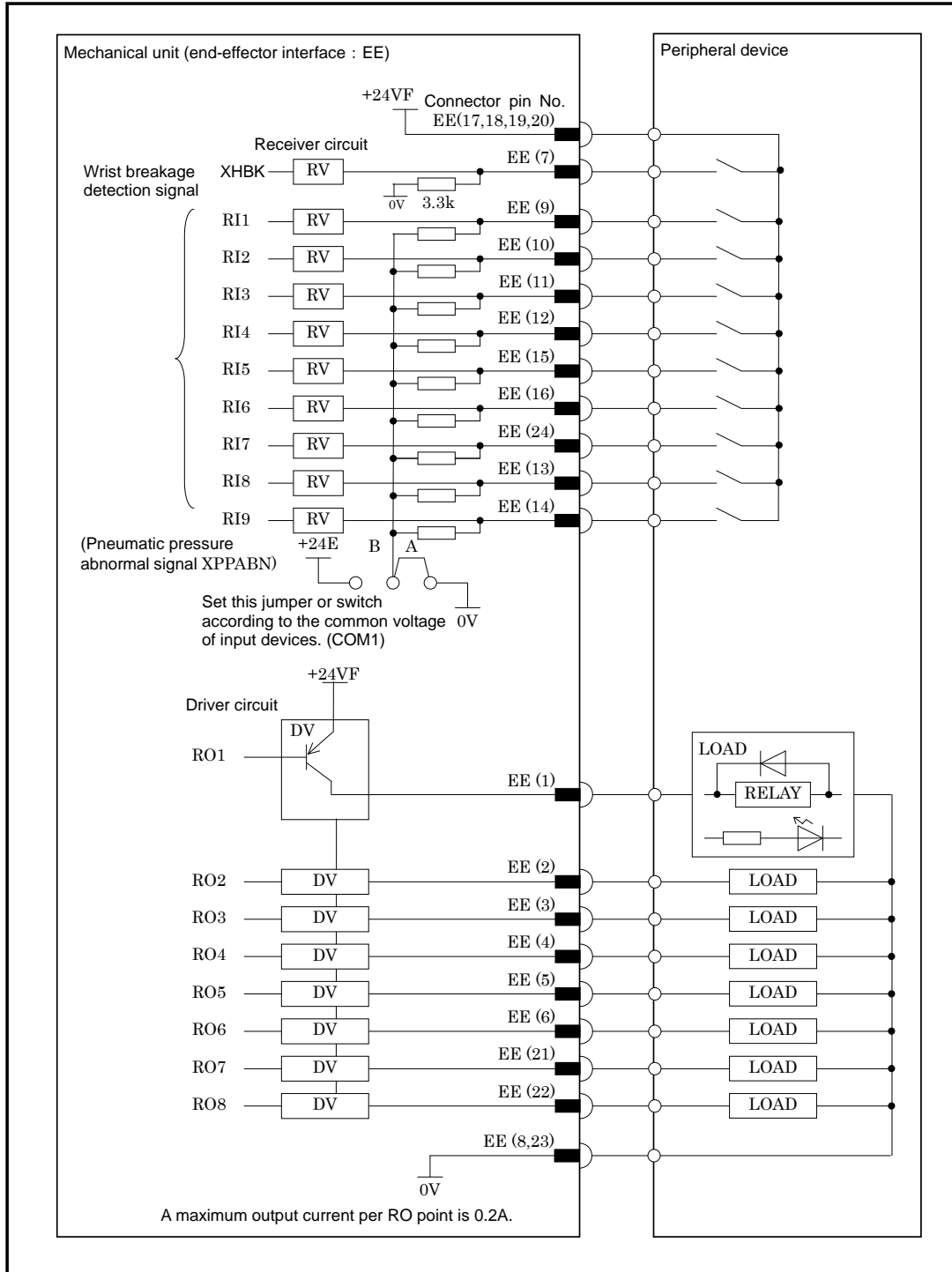


Fig.4.4.2 Connection between the ARC Mate 100iC/M-10iA, ARC Mate 120iC/M-20iA, ARC Mate 0iA and end effector

Note) For end effector figures other than the above (eight RI/RO signals for each), refer to the operator's manual of each robot.



NOTE

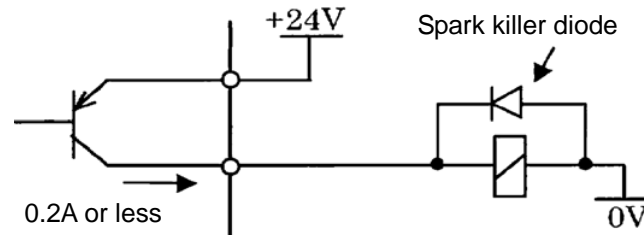
- 1 In this diagram, common voltage of input device is +24V.
- 2 The common-level change-over setting pin or switch (COM1) is in the 6-axis servo amplifier.

4.5 DIGITAL I/O SIGNAL SPECIFICATIONS

This section describes the specifications of the digital I/O signals interfaced with the peripheral device, end effector, and arc welder.

4.5.1 Peripheral Device Interface

- (1) Output signals in peripheral device interface (Source type DO)
(a) Example of connection

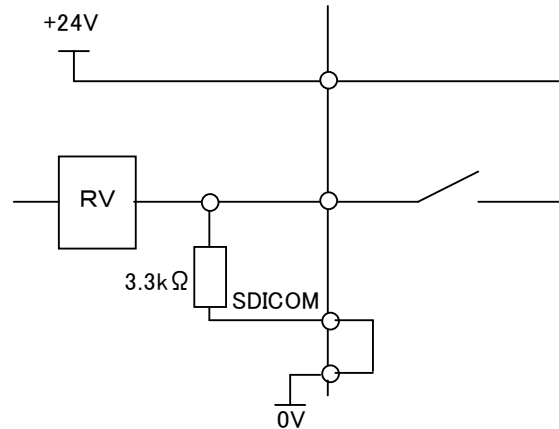


- (b) Electrical specifications
 Maximum load current when driver is on: 200 mA (including momentary level)
 Saturation voltage when driver is on: 1.0 V max.
 Dielectric strength: 24 V \pm 20% (including momentary level)
 Leakage current when driver is off: 100 μ A
- (c) The external power supply to output signals must satisfy the following:
 Power supply voltage: +24 V \pm 10%
 Power supply current:
 For each printed circuit board of this type
 (Total sum of maximum load currents including momentary levels + 100 mA or more)
 Power-on timing:
 At the same time when the control unit is turned on or earlier
 Power-off timing:
 At the same time when the control unit is turned off or later
- (d) Spark killer diode
 Rated peak reverse voltage: 100 V or more
 Rated effective forward current: 1 A or more
- (e) Driver for output signals
 In the driver device, the current of each output signal is monitored, and when an overcurrent is detected, the relevant output is turned off. After an output has been turned off by overcurrent, the overcurrent state is released because the output is off, so the output on state is restored. Therefore, in the ground fault or overcurrent state, the output is turned on and off repeatedly. Such a condition is found also when a load with a high surge current is connected.
 The driver device also includes an overheat detection circuit, which turns off all outputs of the device when the internal temperature of the device has increased as a result of a continued overcurrent state due to a ground fault of an output and so on. The outputs are held off, but their normal states can be restored by turning the power to the controller on and off after the internal temperature of the device has lowered.
- (f) Note on use
 When adding a relay, solenoid, or the like directly to the circuit, connect a diode for counter electromotive voltage protection in parallel to the load.
- (g) Applicable signals
 Output signals of main board I/O board CRMA15 and CRMA16
 CMDENBL, FAULT, BATALM, BUSY,
 DO101 to DO120

Output signals of Process I/O board CRMA52A and CRMA52B
DO121 to DO136

(2) Input signals in peripheral device interface A

(a) Example of connection

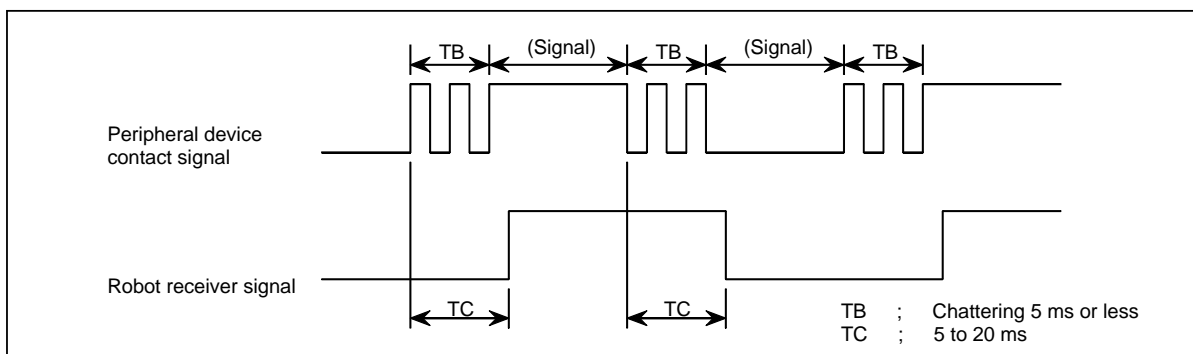


(b) Electrical specifications of the receiver

Type:	Grounded voltage receiver	
Rated input voltage:	Contact close	+20V to +28V
	Contact open	0V to +4V
Maximum applied input voltage:	+28VDC	
Input impedance:	3.3kΩ (approx.)	
Response time:	5ms to 20ms	

(c) Specifications of the peripheral device contact

Voltage and Current:	DC24V, 0.1A
	(Use a contact which minimum load is 5mA less.)
Input signal width:	200ms or more (on/off)
Chattering time:	5ms or less
Closed circuit resistance:	100Ω or less
Opened circuit resistance:	100kΩ or more



(d) Note on use

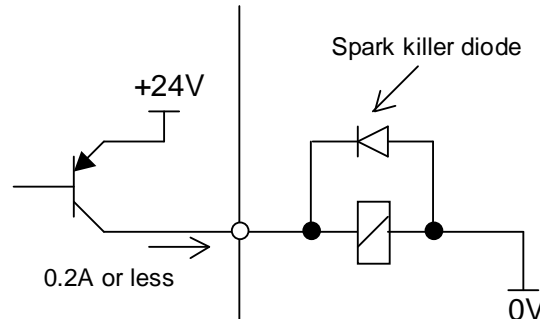
Apply the +24 V power at the robot to the receiver.
However, the above signal specifications must be satisfied at the robot receiver.

(e) Applicable signals

Input signals of main board CRMA15 and CRMA16
XHOLD, FAULT RESET, START, HOME, ENBL
DI101 to DI120
Input signals of Process I/O board CRMA52A and CRMA52B
DI121 to DI140

4.5.2 End Effector Control Interface

- (1) Output signals in end effector interface
(a) Example of connection



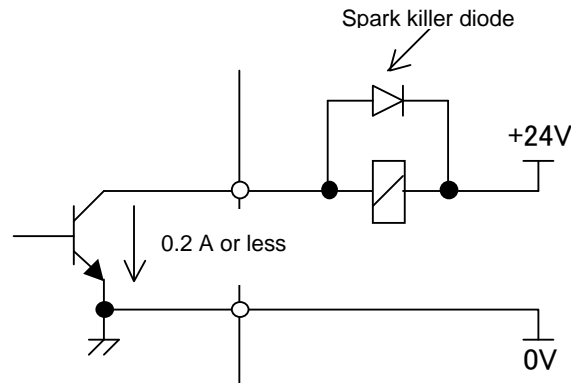
- (b) Electrical specifications
 Maximum load current when driver is on: 200 mA (including momentary level)
 Saturation voltage when driver is on: 1.0 V max.
 Dielectric strength: 24 V \pm 20% (including momentary level)
 Leakage current when driver is off: 100 μ A
- (c) Power supply to output signals
 The +24 V power supply on the robot side can be used if the total current level, including the current of the welding interface, is 0.7 A or less.
- (d) Driver for output signals
 In the driver device, the current of each output signal is monitored, and when an overcurrent is detected, the relevant output is turned off. After an output has been turned off by overcurrent, the overcurrent state is released because the output is off, so the output on state is restored. Therefore, in the ground fault or overcurrent state, the output is turned on and off repeatedly. Such a condition is found also when a load with a high surge current is connected.
 The driver device also includes an overheat detection circuit, which turns off all outputs of the device when the internal temperature of the device has increased as a result of a continued overcurrent state due to a ground fault of an output and so on. The outputs are held off, but their normal states can be restored by turning the power to the control unit on and off after the internal temperature of the device has lowered.
- (e) Note on use
 When adding a relay, solenoid, or the like directly to the circuit, connect a diode for counter electromotive voltage protection in parallel to the load.
- (f) Applicable signals
 RO1 to RO8

- (2) Input signal in peripheral device interface
 The input signals are the same as those of other I/O boards. (Refer to Subsection 4.5.1 in CONNECTIONS.)

- (a) Applicable signals
 RI1 to RI8, XHBN, XPPABN

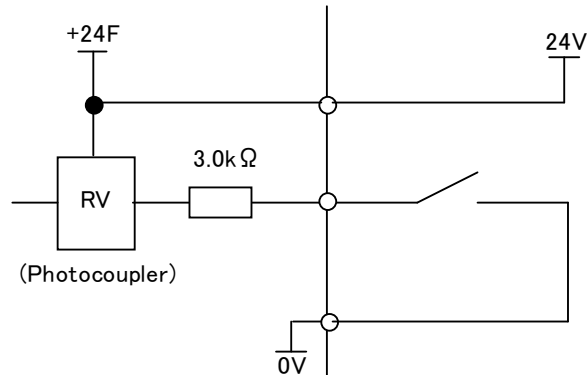
4.5.3 Specification for Arc Welding Machine Interface Input/Output Signals

- (1) Specification for arc welding machine interface digital output signals
 (a) Example of connection



- (b) Electrical specifications
- | | |
|--|--------------------|
| Rated voltage: | 24VDC |
| Maximum applicable voltage: | 30VDC |
| Maximum load current: | 0.2A |
| Transistor type: | Open-collector NPN |
| Saturation voltage when the circuit is on: | Approximately 1.0V |
- (c) Spark killer diode
- | | |
|---|-----------------|
| Rated peak-to-peak reverse withstand voltage: | 100 V or higher |
| Rated effective forward current: | 1 A or more |
- (d) Caution for use
- The arc welding machine interface can use the +24V power supply of the robot unless the sum of its sink current and that of the end effector control interface exceeds 0.7A. When using a relay or solenoid directly as a load, connect the load and a back electromotive force voltage prevention diode in parallel.
- When using a load, such as a lamp, that generates surge current when it is turned on, install a protection resistor.
- (e) Applicable signals
- Arc welding machine interface output signals
 [WO1, 2,4,5]

- (2) Specification for arc welding machine interface digital output signals
(a) Example of connection

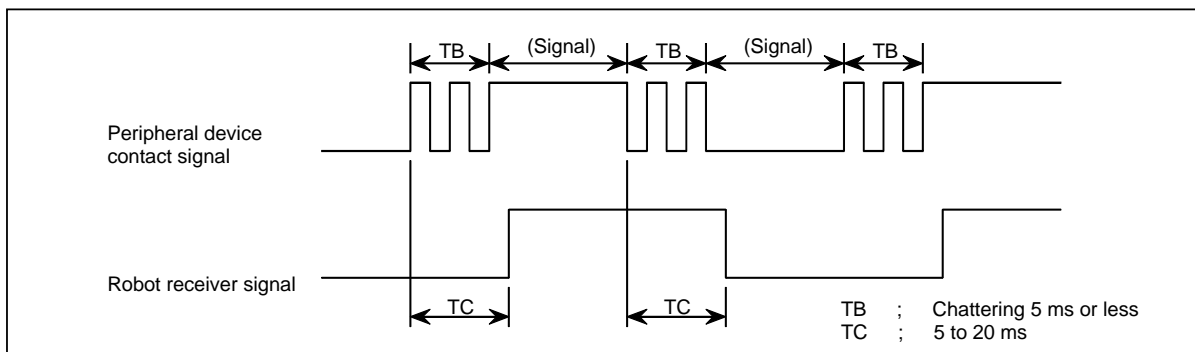


- (b) Electrical specifications of the receiver

Type:	Grounded voltage receiver
Rated input voltage:	Contact close +20V to +28V
	Contact open 0V to +4V
Maximum applied input voltage:	+28VDC
Input impedance:	3.0kΩ (approx.)
Response time:	5ms to 20ms

- (c) Specifications of the peripheral device contact

Voltage and Current:	DC24V, 0.1A
	(Use a contact which minimum load is 5mA less.)
Input signal width:	200ms or more (on/off)
Chattering time:	5ms or less
Closed circuit resistance:	100Ω or less
Opened circuit resistance:	100kΩ or more



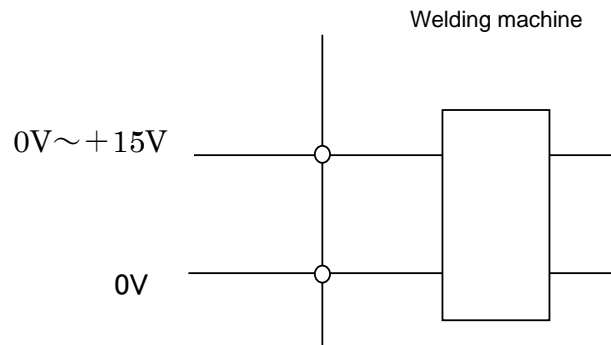
- (d) Note on use

Apply the +24 V power at the robot to the receiver.
However, the above signal specifications must be satisfied at the robot receiver.

- (e) Applicable signals

Arc welding machine interface input signals
[WI2~6]

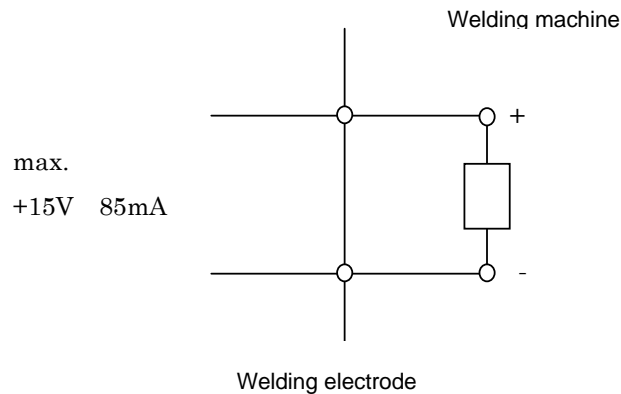
- (3) Specification for arc welding machine interface analog output signals (welding voltage and wire feed speed specification signals)
 (a) Example of connection



- (b) Caution for use
 Input impedance: 3.3 k Ω or higher
 Install a high-frequency filter.

(Wire deposit detection: WDI+ and WDI-)

- (a) Example of connection



(Wire deposition detection: WDI+, WDI-)

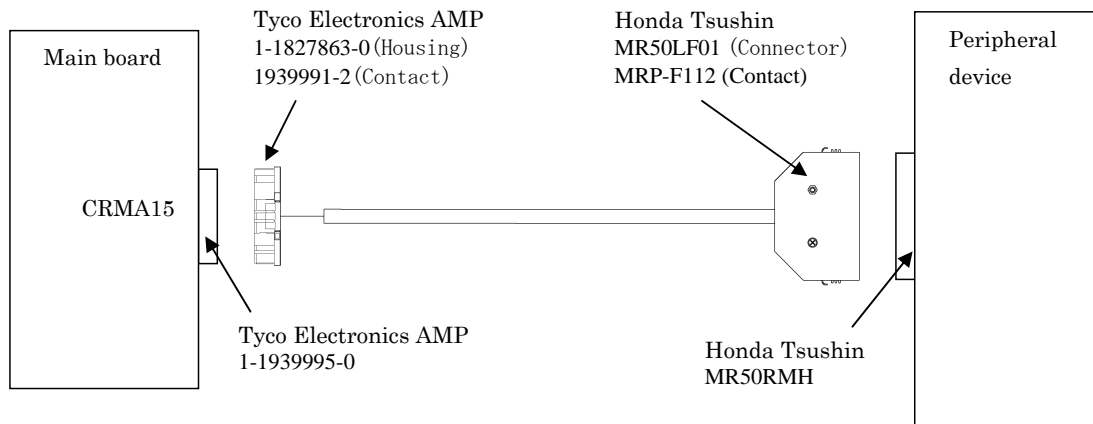
- (b) Caution for use
 The resistance between the + and - terminals of the welding machine must be 100 Ω or higher.
 The TIG welding deposition detection circuit must be isolated from the welding circuit (high frequency).
 This circuit can withstand up to 80 V.

4.6 SPECIFICATIONS OF THE CABLES USED FOR PERIPHERAL DEVICES AND WELDERS

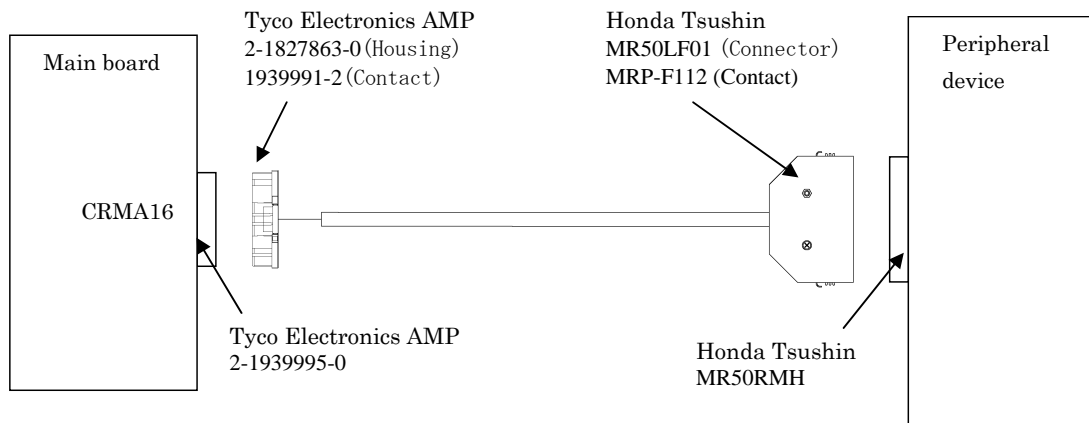
If the customer manufactures cables, make sure they conform to the FANUC standard cables described in this section.

(See the description in "Peripheral Device Interface" in this manual for the specifications of the FANUC standard cables.)

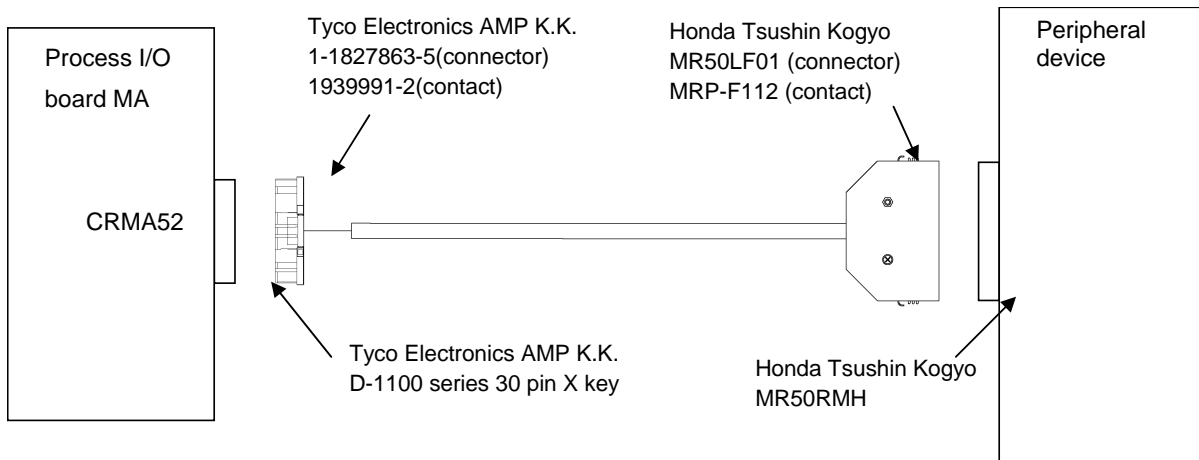
4.6.1 Peripheral Device Interface A1 Cable (CRMA15: Tyco Electronics AMP, D-1000 series, 40 pins)



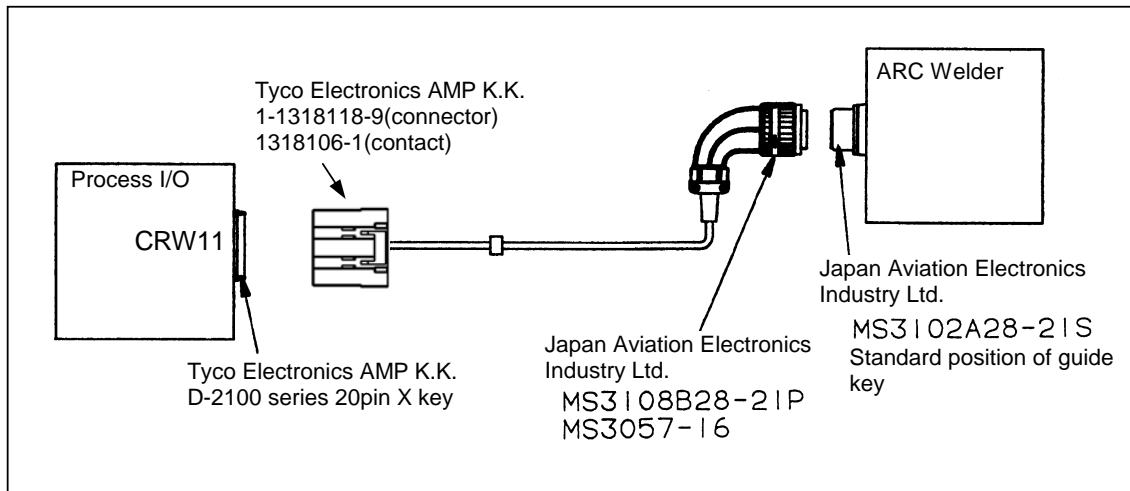
4.6.2 Peripheral Device Interface A2 Cable (CRMA16: Tyco Electronics AMP, D-1000 series, 40 pins)



4.6.3 Peripheral Device Interface B1 and B2 Cables (CRMA52; Tyco Electronics AMP K.K. 30 pin)



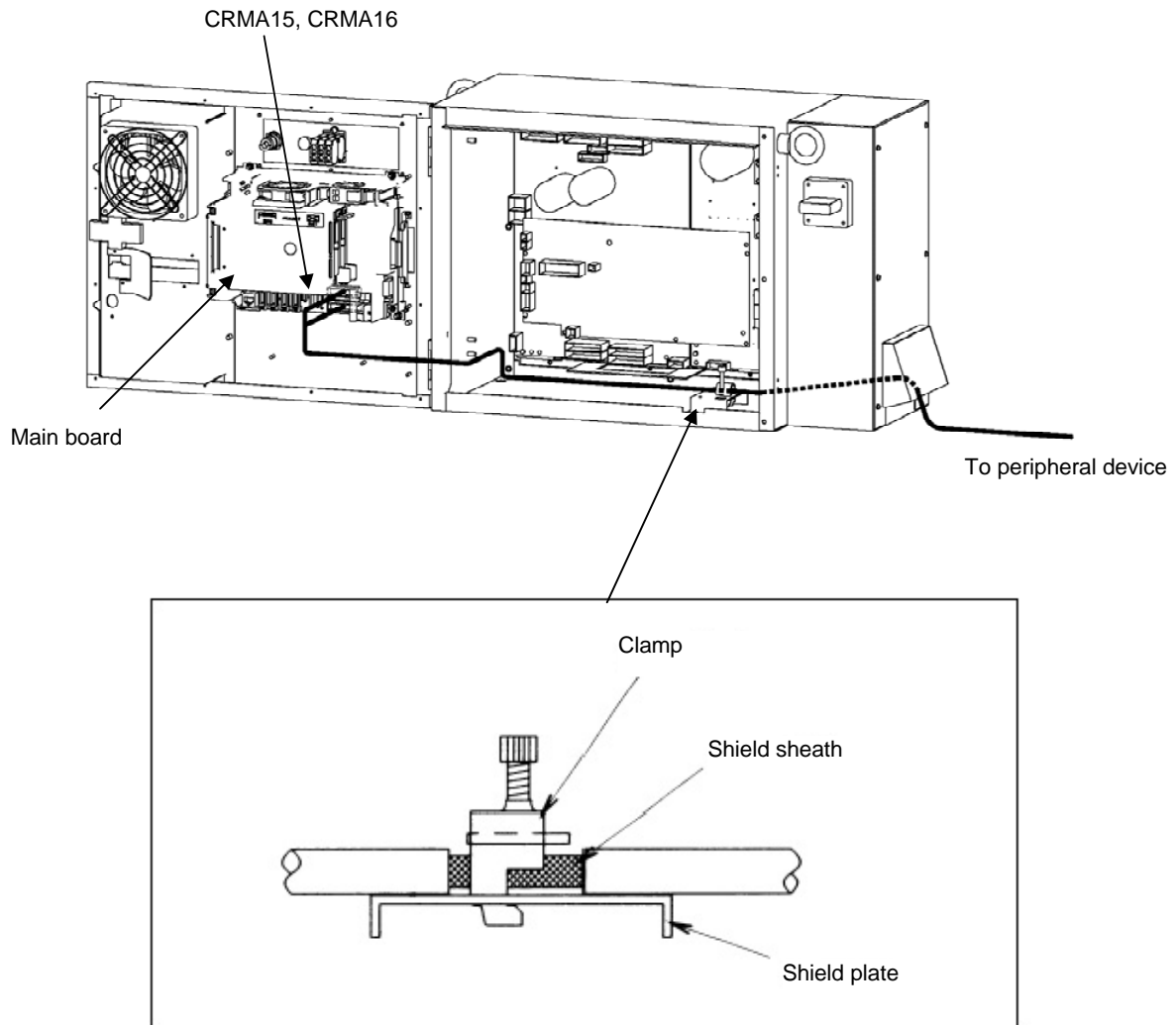
4.6.4 ARC Weld Connection Cables (CRW11; Tyco Electronics AMP K.K. 20 pin)



4.7 CABLE CONNECTION FOR THE PERIPHERAL DEVICES

4.7.1 Peripheral Device Connection Cable

Fig.4.7.1 shows the connection of the peripheral device cable in the cabinet.

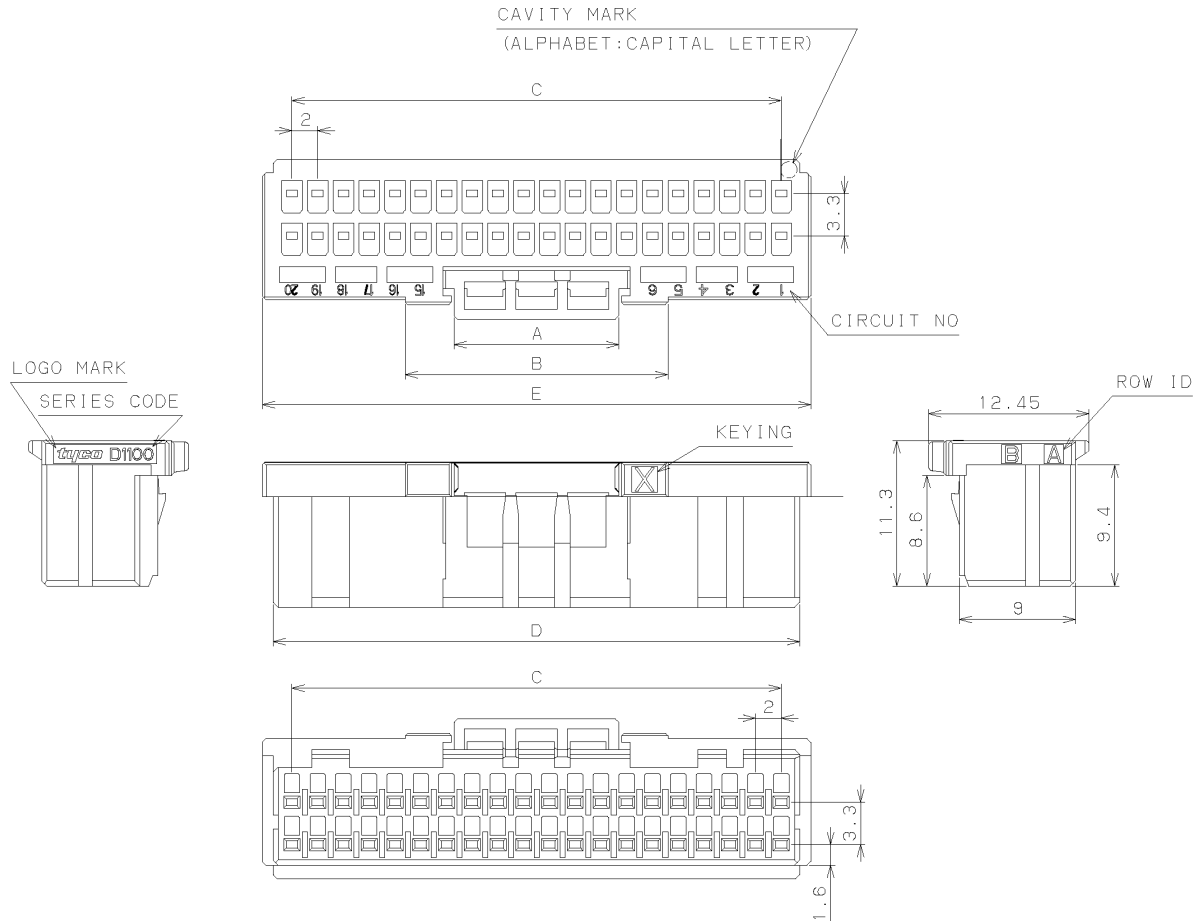


For noise protection, cut part of the jacket of the peripheral device cable to expose the shield sheath, and fasten this part to the shield plate with the clamp.

Fig.4.7.1 Peripheral device cable connection

4.7.2 Peripheral Device Cable Connector

(1) Fig.4.7.2 shows the connector for peripheral device cables A1 and A2.

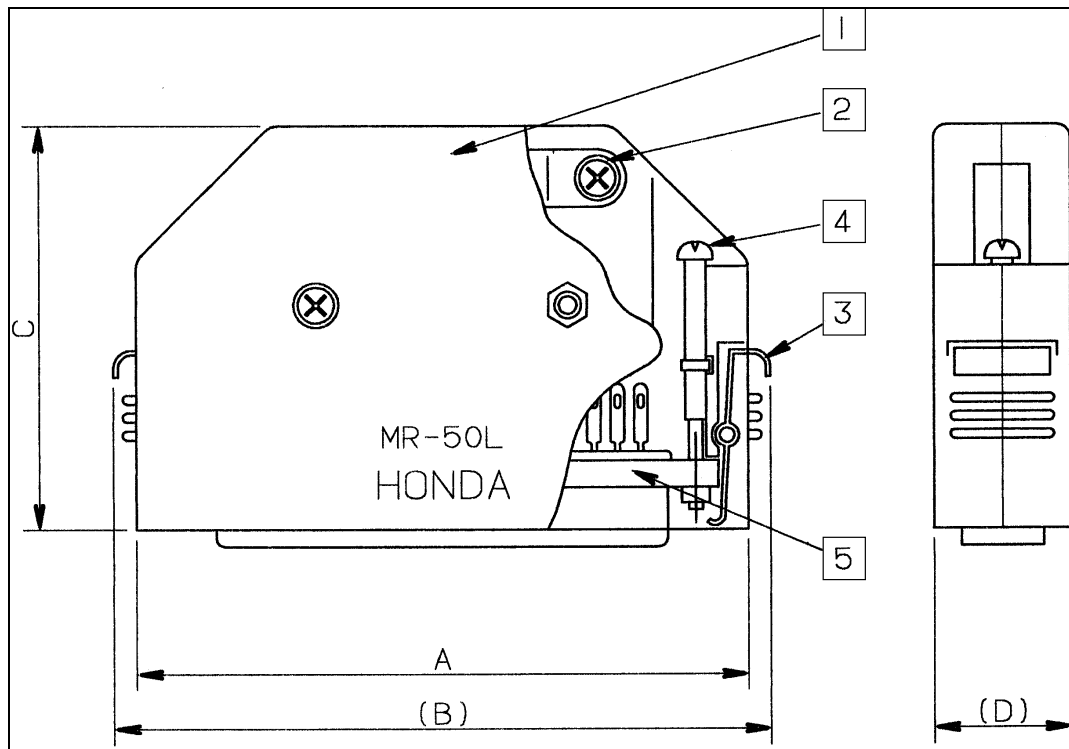


Connector specifications	Applicable interface	Dimensions					Remark
		A	B	C	D	E	
1-1827863-0 (Housing)	CRMA15	12.8	20.4	38.0	40.9	42.6	Tyco Electronics AMP D-1000 series 40pin (X-key)
2-1827863-0 (Housing)	CRMA16						Tyco Electronics AMP D-1000 series 40pin (Y-key)
1-1827863-5 (Housing)	CRMA52	12.8	20.4	28.0	30.9	32.6	Tyco Electronics AMP D-1000 series 30pin (X-key)
1939991-2 (Contact)	CRMA15 CRMA16	/	/	/	/	/	Tyco Electronics AMP D-1000 series

Maintenance tool

Hand tool (for crimping contact) 1762846-1:A05B-2550-K060
Extraction tool 1891526-1:A05B-2550-K061

Fig.4.7.2 (a) Peripheral device cable connector (Tyco Electronics AMP)

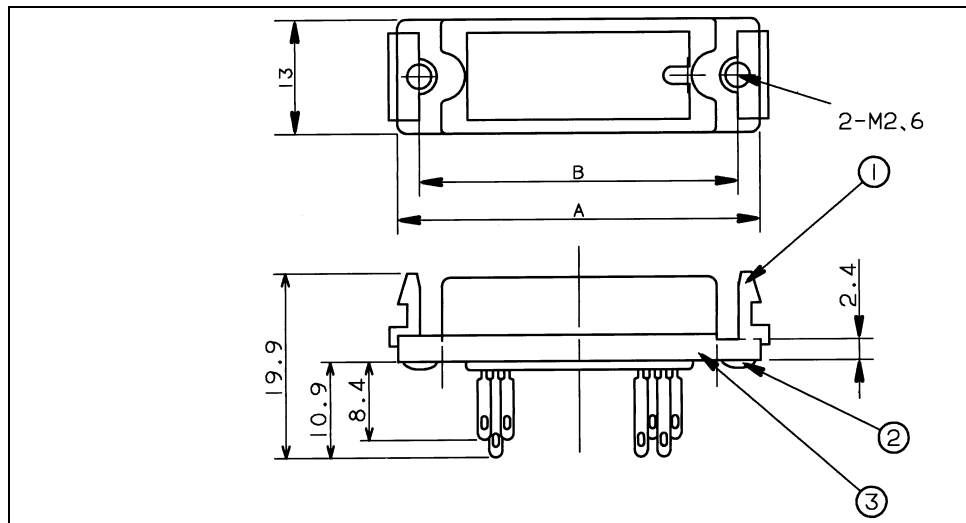


Connector specifications	Applicable interface	Dimensions				Remark
		A	(B)	C	(D)	
MR50LF (Connector)	CRMA15 CRMA16	67.9	73.5	44.8	18	Honda Tsushin Kogyo, 50 pins, female
MR50LM (Connector)	CRMA58 CRMA59	67.9	73.5	44.8	18	Honda Tsushin Kogyo, 50 pins, male
MRP-F112 (Contact)	CRMA15 CRMA16	/	/	/	/	Honda Tsushin Kogyo

Symbol	Name
1	Connector cover
2	Cable clamp screw
3	Connector clamp spring
4	Connector clamp screw
5	Connector 50 pins (female) MR50LF

Fig.4.7.2 (b) Peripheral device cable connector (Honda Tsushin Kogyo)

(2) Peripheral device connector



Connector specifications	Applicable interface	Dimensions		Remark
		A	B	
MR50RM	(CRMA15) (CRMA16)	61.4	56.4	Honda Tsushin Kogyo, 50 pins

Symbol	Name
1	Connector clamp screw
2	Screw M2.6 8
3	Connector (MR50RM)

Fig.4.7.2 (c) Peripheral device connector (Honda Tsushin Kogyo)

4.7.3 Recommended Cables

(1) Peripheral device connection cable

Connect a peripheral device using a completely shielded, heavily protected cable conforming to the specifications in Table 4.7.3 (a).

Allow an extra 50 cm for routing the cable in the control unit.

The maximum cable length is 30 m.

Table 4.7.3 (a) Recommended cable (for peripheral device connection)

Number of wires	Wire specifications (FANUC specifications)	Conductor		Sheath thickness (mm)	Effective outside diameter (mm)	Electrical characteristics	
		Diameter (mm)	Configuration			Conductor resistance (Ω /km)	Allowable current (A)
50	A66L-0001-0042	ϕ 1.05	7/0.18 AWG24	1.5	ϕ 12.5	106	1.6A

(2) End effector connection cable

Connect an end effector using a heavily protected cable with a movable wire conforming to the specifications in Table 4.7.3(b).

The cable length is determined so that the cable will not interfere with the end effector and the wrist can move through its full stroke.

Table 4.7.3 (b) Recommended cable (for end effector connection)

Number of wires	Wire specifications (FANUC specifications)	Conductor		Sheath thickness (mm)	Effective outside diameter (mm)	Electrical characteristics	
		Diameter (mm)	Configuration			Conductor resistance (Ω/km)	Allowable current (A)
6	A66L-0001-0143	ϕ 1.1	40/0.08 AWG24	1.0	ϕ 5.3	91	3.7
20	A66L-0001-0144	ϕ 1.1	40/0.08 AWG24	1.0	ϕ 8.6	91	2.3
24	A66L-0001-0459	ϕ 0.58	40/0.08 AWG24	1.0	ϕ 8.3	93	2.3

4.8 CONNECTING THE COMMUNICATION UNIT

4.8.1 RS-232-C Interface

4.8.1.1 Interface

This interface can be connected to a communication unit from FANUC.

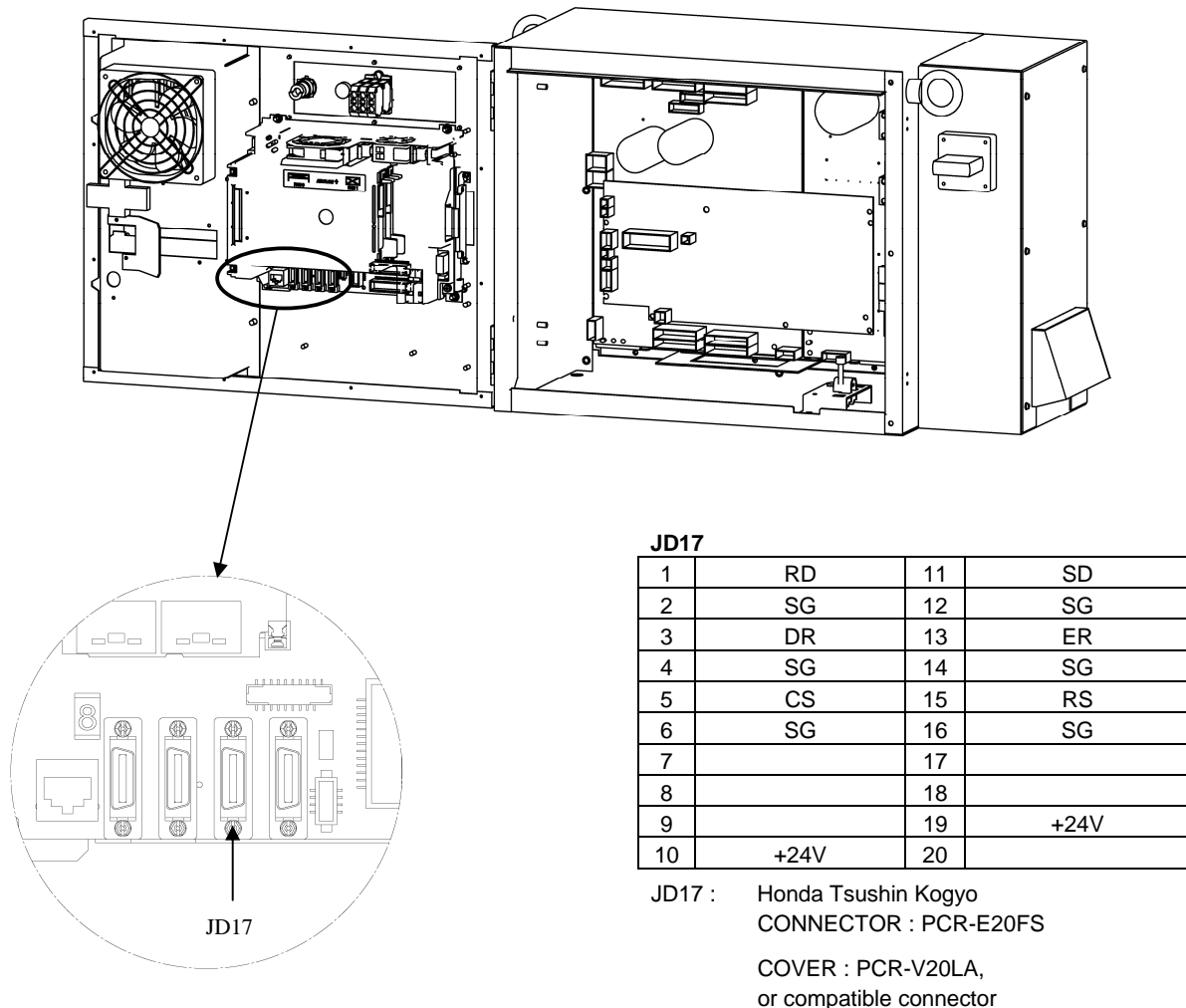


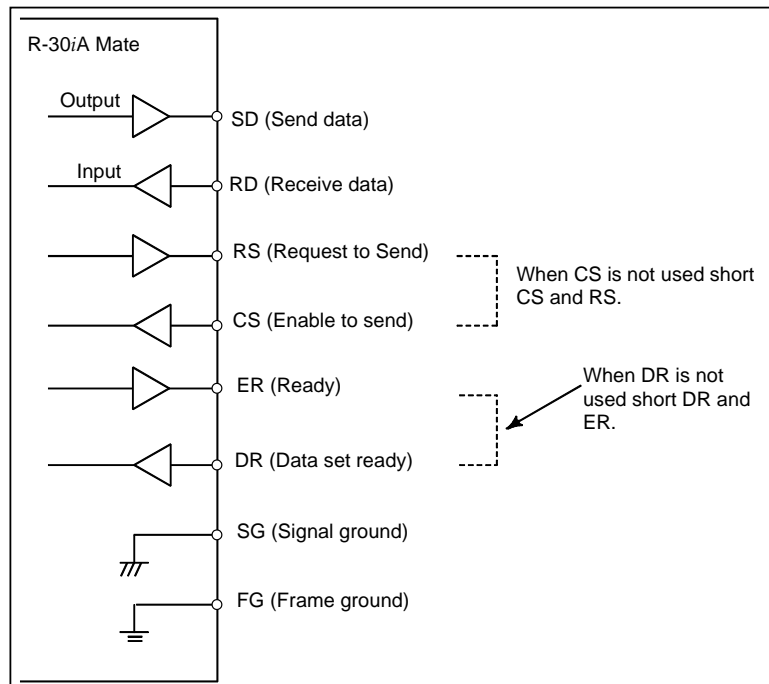
Fig.4.8.1.1 RS-232-C interface

NOTE

- 1 +24V can be used as the power supply for FANUC RS-232-C equipment.
- 2 Do not connect anything to those pins for which signal names are not indicated.

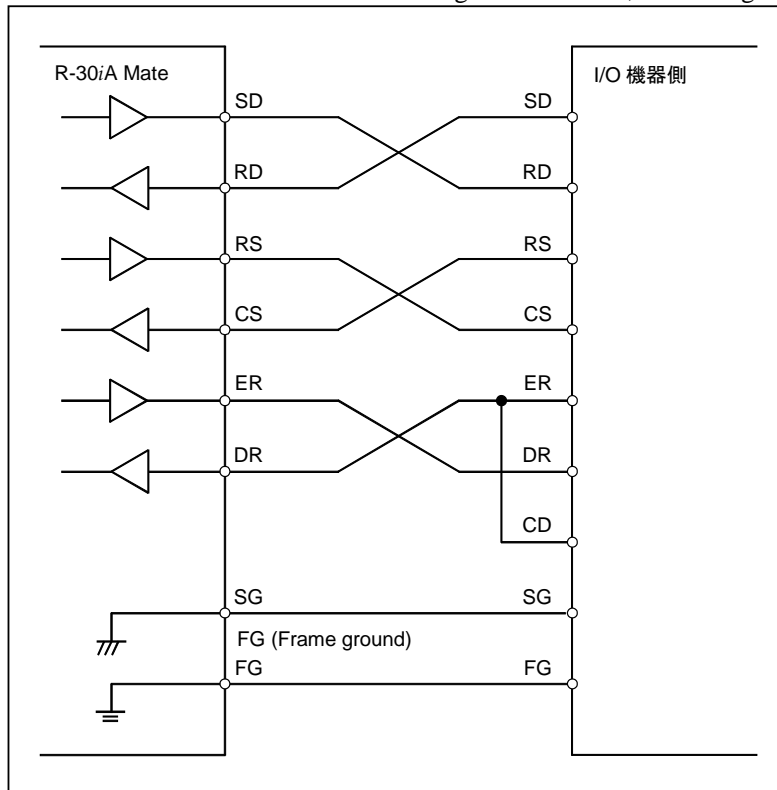
4.8.1.2 RS-232-C interface signals

Generally signals as follows are used in RS-232-C interface.

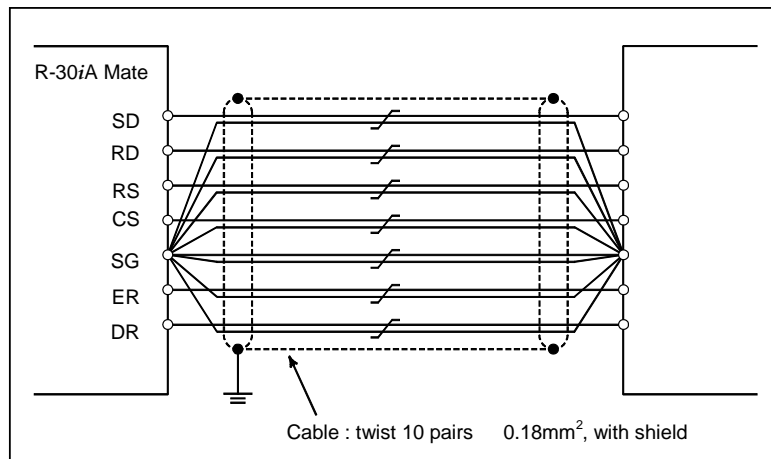
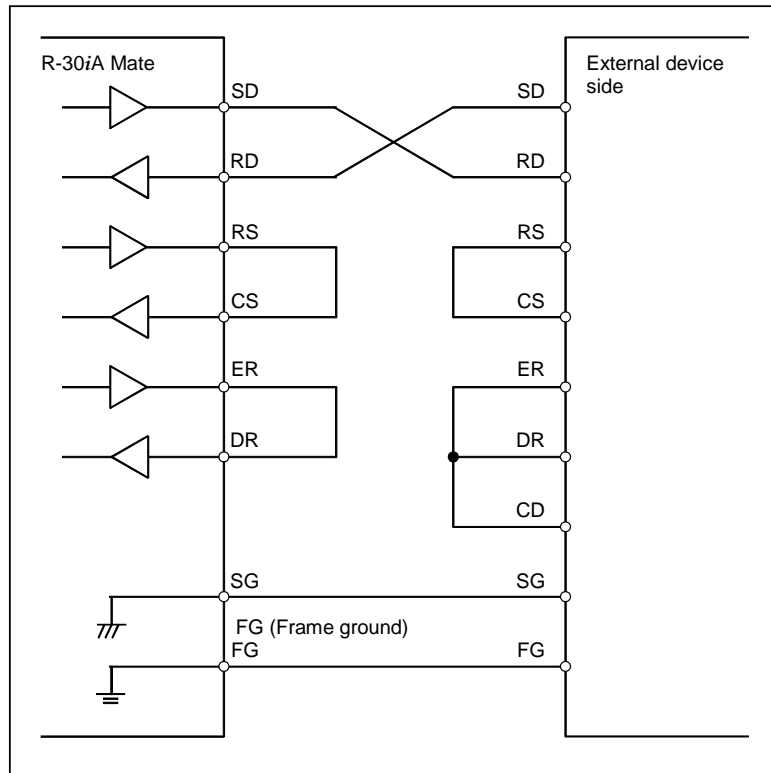


4.8.1.3 Connection between RS-232-C interface and I/O device

The figure below shows a connection with the handshaking of the ER/DR, RS/CS signals.



- The figure below shows a connection without the handshaking of the RS/CS, ER/DR signals.



Cable connection

Pair each signal with SG.

4.8.2 Ethernet Interface

This section describes information relating to the physical Ethernet connection.

⚠ CAUTION

- 1 Before connecting or disconnecting the cable to or from the FAST Ethernet/FAST Data Server, make sure that the power to the CNC is turned off.
- 2 Please inquire of each manufacturer about the construction of network or the condition of using the equipment except the FAST Ethernet/FAST Data Server (hub, transceiver, cable etc.). When configuring your network, you must take other sources of electrical noise into consideration to prevent your network from being influenced by electrical noise. Make sure that network wiring is sufficiently separated from power lines and other sources of electrical noise such as motors, and ground each of the devices as necessary. Also, high and insufficient ground impedance may cause interference during communications. After installing the machine, conduct a communications test before you actually start operating the machine.

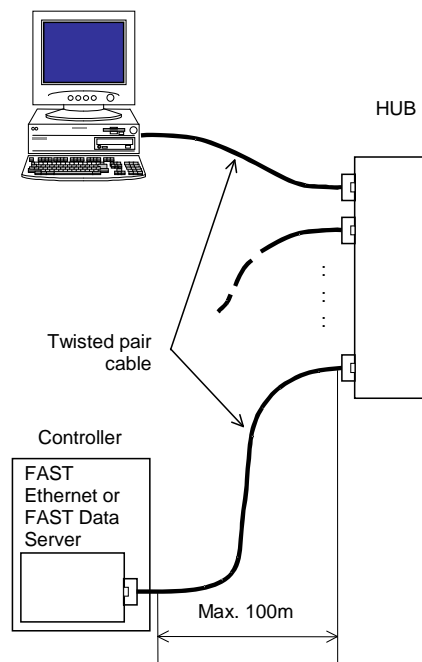
We cannot ensure operation that is influenced by network trouble caused by a device other than the FAST Ethernet or FAST Data Server.

4.8.2.1 Connection to Ethernet

The FAST Ethernet or FAST Data Server is provided with a 100BASE-TX interface.

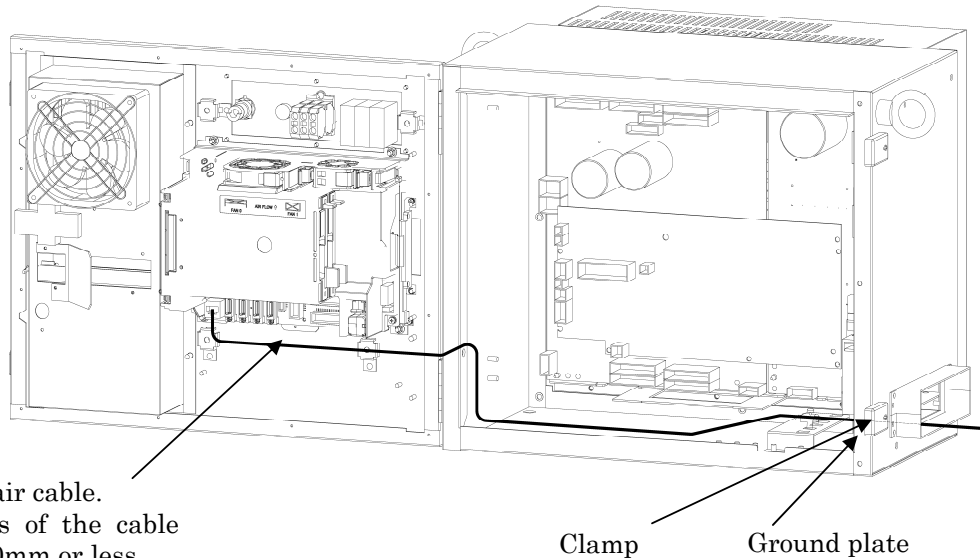
Prepare a hub for connecting the FAST Ethernet board to the Ethernet trunk. The following shows an example of a general connection.

Some devices (hub, transceiver, etc.) that are needed for building a network do not come in a dust-proof construction. Using such devices in an atmosphere where they are subjected to dust or oil mist will interfere with communications or damage the FAST Ethernet or FAST Data Server. Be sure to install such devices in a dust-proof cabinet.



4.8.2.2 Leading out the Ethernet cable

For this type of control unit, the cable is drawn out only from the front of the control unit. See the outline drawing of each type of board for the location of the connector.



Twisted-pair cable.
The radius of the cable
must be 70mm or less.

The Ethernet cable must be fastened by a cable clamp to prevent tension being applied to the modular connector (RJ-45) that connects the cable to the control unit even if the Ethernet cable is pulled directly. This clamp is also used to ground the cable shield.

4.8.2.3 100BASE-TX connector (CD38R) pin assignments

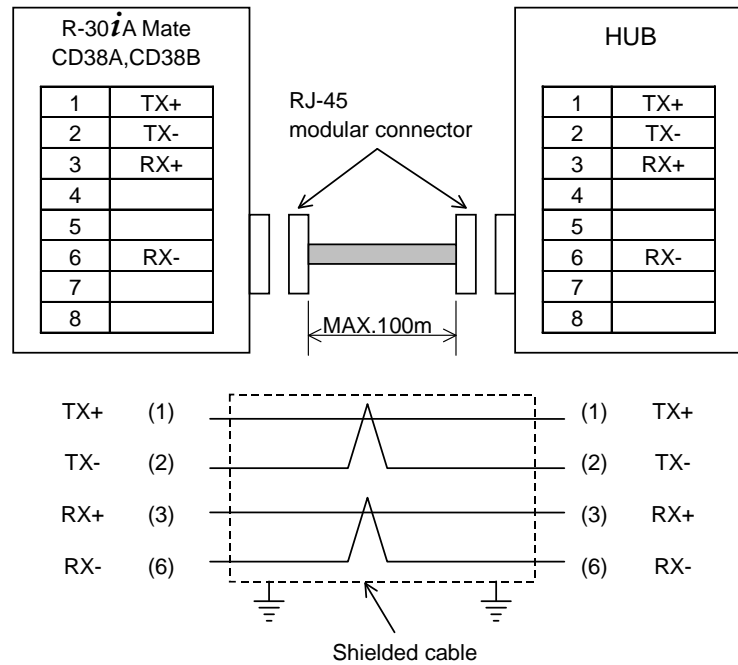
Table 4.8.2.3 CD38R

Pin No.	Signal name	Description
1	TX+	Send +
2	TX-	Send -
3	RX+	Receive +
4		Not used
5		Not used
6	RX-	Receive -
7		Not used
8		Not used

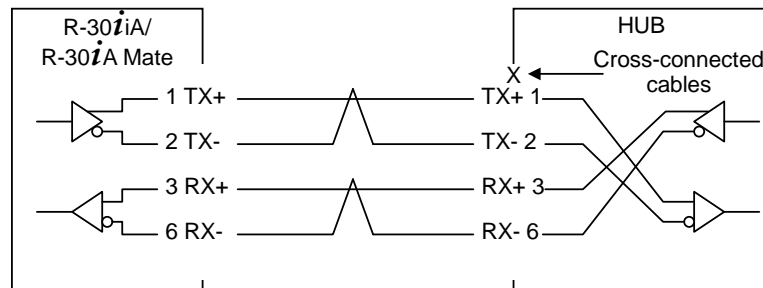
4.8.2.4 Twisted-pair cable specification

Cable Connection

The cable used for connection between the 100BASE-TX interface, CD38, of the controller and the hub is connected as follows:



- Keep the total cable length within 100 m.
Do not extend the cable more than is necessary.
- The figure above shows the cable connection when cables are crossed in the hub. "X" is usually indicated at the port of the hub to signify that cables are crossed in the hub.



Cable Materials

⚠ CAUTION
Unshielded cable (UTP cable) is commercially available as 100BASE-TX twisted-pair cable: You should, however, use shielded Category 5 twisted-pair cable (STP cable) to improve the resistance to electrical noise in an FA environment.

Table 4.8.2.4(a) Recommended cables

Manufacturer	Specification	Remarks
FURUKAWA ELECTRIC CO., LTD.	DTS5087C-4P	Twisted-pair cable
NISSEI ELECTRIC CO., LTD.	F-4PFWMF	Single-conductor cable

Table 4.8.2.4(b) Inquiries

Manufacturer	Contact address
FURUKAWA ELECTRIC CO., LTD. Sales Headquarters	2-6-1 Marunouchi, Chiyoda-ku. Tokyo 100-8322 TEL: 03-3286-3126 FAX: 03-3286-3979
Remarks	
NISSEI ELECTRIC CO., LTD. Machida Branch Overseas Sales Office	3F MU Bldg., 1-9-1 Minami-narise, Machida City, Tokyo 194-0045 TEL: 0427-29-2531 FAX: 0427-29-3375 IWATANI International Corporation Tokyo Head Office 21-8 Nishi-shinbashi 3-chome, Minato-ku, TOKYO, 105-8458, JAPAN TEL: 03-5405-5810 FAX: 03-5405-5666 Telex: 2524256 IWATYO J
Remarks	A finished cable with connectors at both ends can be offered.

NOTE

The recommended cables cannot be connected to moving parts.

Table 4.8.2.4(c) Recommended cable (for movable parts)

Manufacturer	Specification	Remarks
Oki Electric Cable Co., Ltd.	AWG26 4P TPMC-C5-F (SB)	Dedicated to
Shinko Electric Industrial Co., Ltd.	FNC-118	FANUC

Specification

- Electric characteristics:
Conforms to EIA/TIA 568A Category 3 and Category 5.
From the viewpoint of attenuation performance, ensure that the length to the hub is 50 m or less.
- Structure:
Group shielded (braided shield). A drain wire is available.
The conductor is an AWG26 annealed copper twisted wire, with a sheath thickness of 0.8 mm and an outer diameter of 6.7 mm ±0.3 mm.
- Fire retardancy
UL1581 VW-1
- Oil resistance
Conforms to the FANUC internal standards (equivalent to the conventional oil-resistant electric cables).
- Flexing resistance:
1,000,000 times or more with a bending radius of 50 mm (U-shaped flex test)
- UL style No.
AWM 20276 (80°C/30V/VW-1)

NOTE

Be sure to use the connector TM21CP-88P (03) manufactured by HIROSE ELECTRIC CO., LTD. for this cable.

Table 4.8.2.4(d) Inquiries

Manufacturer	Contact address
Oki Electric Cable Co., Ltd.	Nagano Sales Office TEL:0266-27-1597
Remarks	
Shinko Electric Industrial Co., Ltd.	Tokyo Sales Office TEL:03-3492-0073
Remarks	

Cable assembly

Oki Electric Cable Co., Ltd. can also supply the cable assembly mentioned above.

Contact Oki Electric directly to determine the specifications (length, factory test, packing, and so forth) for purchase.

Connector Specification

Use an 8-pin modular connector (RJ-45) with the twisted-pair cable for the Ethernet connection. The following connectors or equivalents must be used.

For general use	Specification	Manufacturer	Remarks
Solid wire	5-569530-3	Tyco Electronics AMP K.K..	
Solid wire	MS8-RSZT-EMC	SK KOHKI CO., LTD.	Special tools required
Twisted-pair cable	5-569552-3	Tyco Electronics AMP K.K..	
Twisted-pair cable	TM11AP-88P	HIROSE ELECTRIC CO., LTD.	Special tools required

For movable parts	Specification	Manufacturer	Remarks
For cable AWG26 4P TPMC-C5-F (SB) or FNC-118	TM21CP-88P (03)	HIROSE ELECTRIC CO., LTD.	Note

NOTE

Information about TM21CP-88P (03):
 Connector (standard product of the manufacturer)
 Drawing number: A63L-0001-0823#P
 Manufacturer: HIROSE ELECTRIC CO., LTD.
 Manufacturer type number: TM21CP-88P (03)
 Conforms to EIA/TIA 568A Category 3 and Category 5.
 For assembly with a cable, contact HIROSE ELECTRIC CO., LTD. directly.
 (From HIROSE ELECTRIC CO., LTD., "TM21CP-88P (03) Connection Procedure Manual (Technical Specification No. ATAD-E2367)" is available as a technical document.)

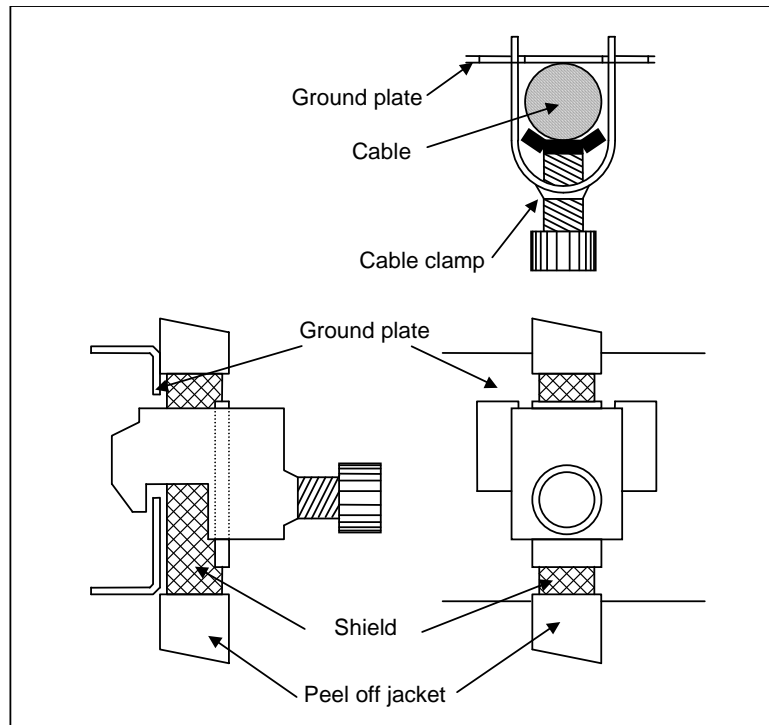
4.8.2.5 Electrical noise countermeasures

Clamping and Shielding Cables

Clamp an Ethernet twisted pair cable according to the method described below, as with cables that need to be shielded. Clamping cables provides support and shielding and is extremely important to the safe operation of the system. Never overlook cable clamping.

Peel off part of the jacket as shown in the figure to expose the outer coating of the shield, and press this outer coating against the ground plate with the clamp fixture.

The machine manufacturer must prepare the ground plate and install it as follows:

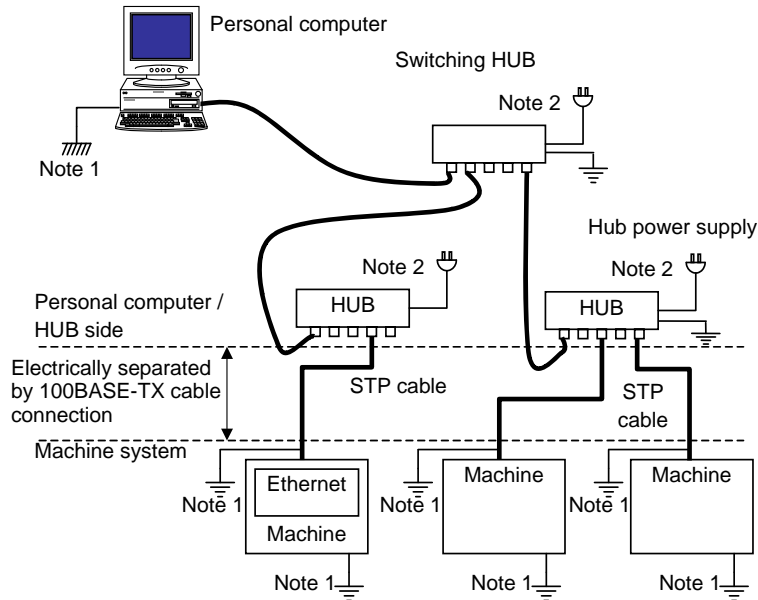
**NOTE**

To ensure the safe operation of the system, clamp and shield the cables.

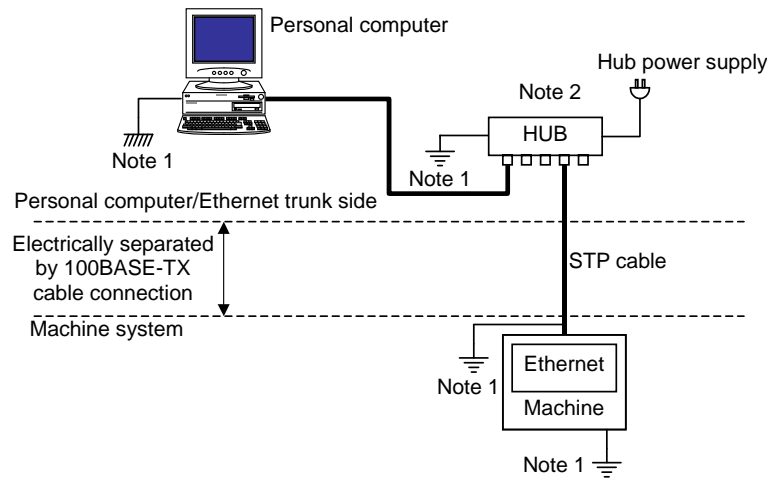
Connect the Ethernet board and hub with a twisted-pair cable. Shield the cable with clamp fixtures.

Grounding the Network

Even if the grounding condition on the machine side is satisfied, the communication line can pick up noise from the machine, depending on the machine installation condition and environment, thus resulting in a communication error. To protect against such noise, the machine should be separated and insulated from the Ethernet trunk cable and personal computer. Examples of connection are given below.



Large-Scale Network



Small-Scale Network

4.8.2.6 Check items at installation

The following table lists check items at installation.

Check item	Description	Check
Ethernet cable		
Type	Use cables which satisfies all the following conditions:	
	1) With shielding	
	2) Twisted-pair cable	
	3) Category 5	
Length	The cable length shall be within 100 m (50 m for a movable cable recommended by FANUC).	
Connection	For a twisted-pair cable, the following pins shall be paired:	
	1) Pin No. 1 (TX+) – pin No. 2 (TX-) 2) Pin No. 3 (RX+) – pin No. 6 (RX-)	
Separation	The Ethernet cables shall be bound separately from the following cables or covered with an electromagnetic shield:	
	1) Group A: AC power lines, power lines for motors, and others 2) Group B: Current DC (24 VDC) and others	
Shielding	For a shielded cable, the part of which outer coating is peeled off and exposed shall be fixed to the ground plate with a clamp fixture.	
Clamping	The ground plate shall be located as nearest to the CNC as possible (to make the cable between the ground plate and CNC hard to be affected by noise).	
Connectors	Any cable connector shall not be pulled (to prevent poor contact of the connector).	
Wiring	No cable shall be laid under a heavy object.	
Bending radius	The bending radius shall be at least four times as long as the diameter of the cable.	
For movable part	For a movable part, a cable for a movable part shall be used.	
CNC and cabinet		
CNC grounding	The CNC ground (frame ground) shall be connected properly and the length of the ground wire shall be within 300 mm.	
Ground plate	The ground plate shall be connected to the AC ground of the cabinet with wire.	
Mounting	The Ethernet board shall be inserted in a CNC slot properly.	
HUB		
Use conditions	The "cautions on use" of the hub shall be observed (A terminating resistor shall be mounted properly if required).	
Grounding	The hub shall be grounded.	
Cabinet	The hub shall be installed in an enclosed cabinet.	
Vibration	The hub shall be installed so that it is not affected by vibration.	
Bending radius	The bending radius shall be at least four times as long as the diameter of the cable.	

5 TRANSPORTATION AND INSTALLATION

This chapter describes the transportation and installation for the controller.

5.1 TRANSPORTATION

The controller is transported by a crane. Attach a strap to eyebolts at the top of the control unit.

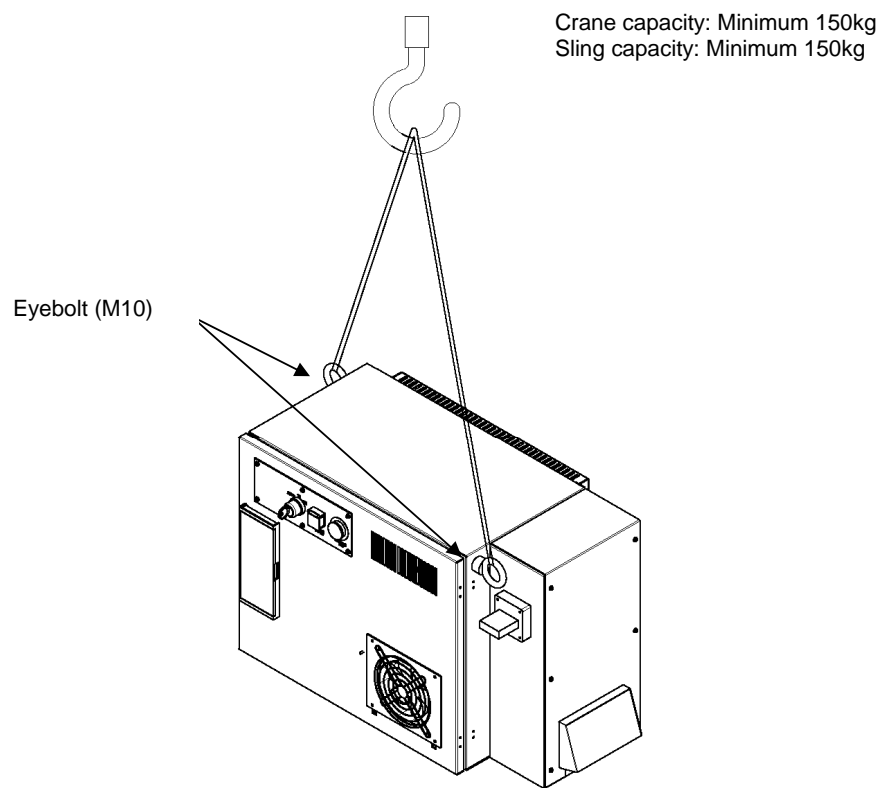


Fig.5.1 Transportation

5.2 INSTALLATION

5.2.1 Installation Method

Following is the installation method for cabinet.

When installing the controller, allow the space for maintenance shown in the following figure.

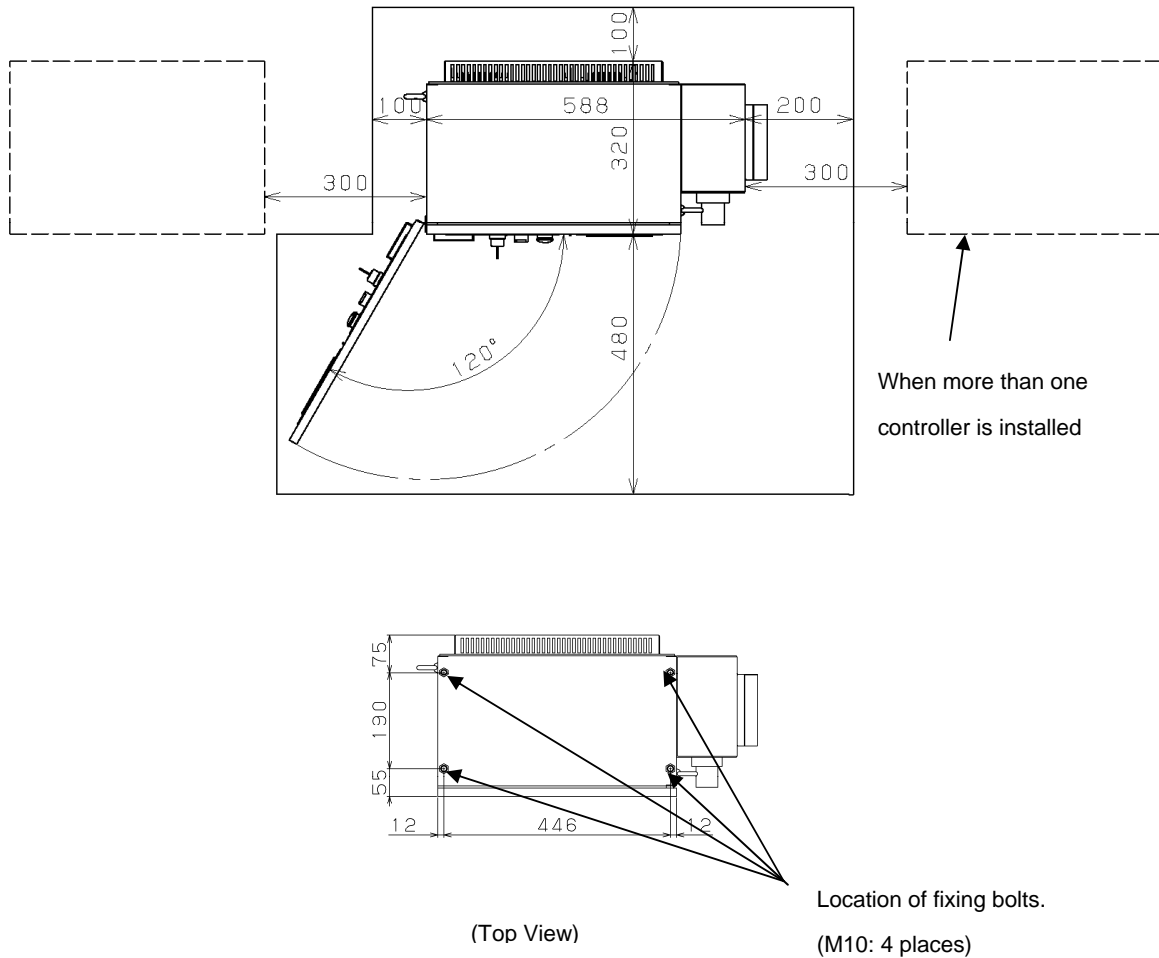
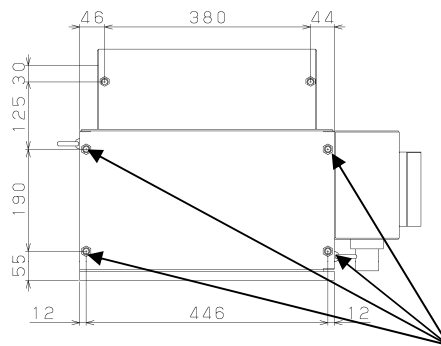
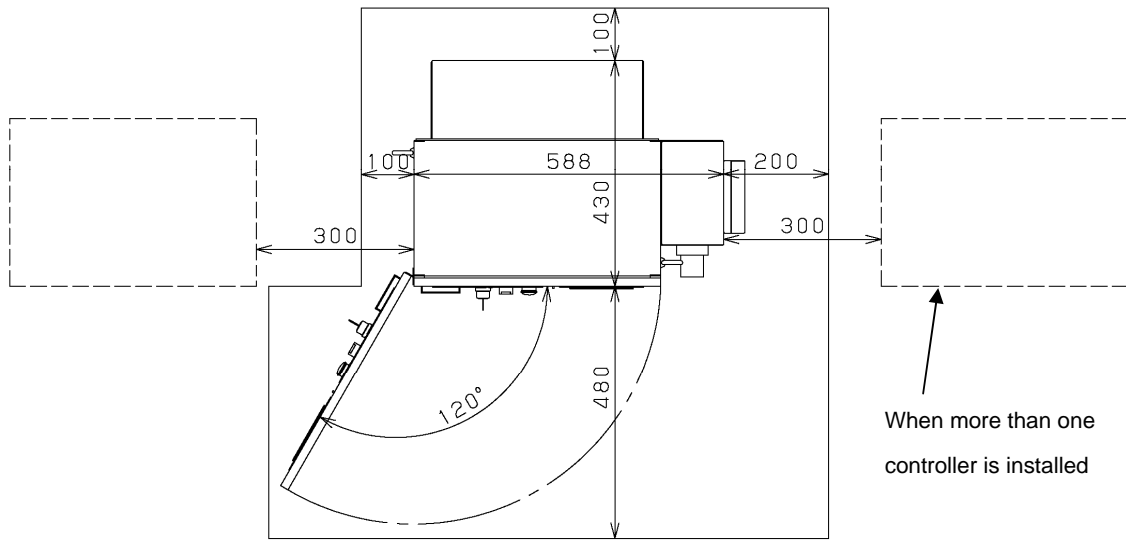


Fig.5.2.1 (a) Installation dimension (LR Mate 200iC, M-1iA)

NOTE

Keep this area for maintenance and the radiation of heat.



(Top View)

Location of fixing bolts.

(M10: 4 places)

Fig.5.2.1 (b) Installation dimension (ARC Mate 100iC, M-10iA, ARC Mate 120iC, M-20iA, ARC Mate 50iC, ARC Mate 0iA)

NOTE
Keep this area for maintenance and the radiation of heat.

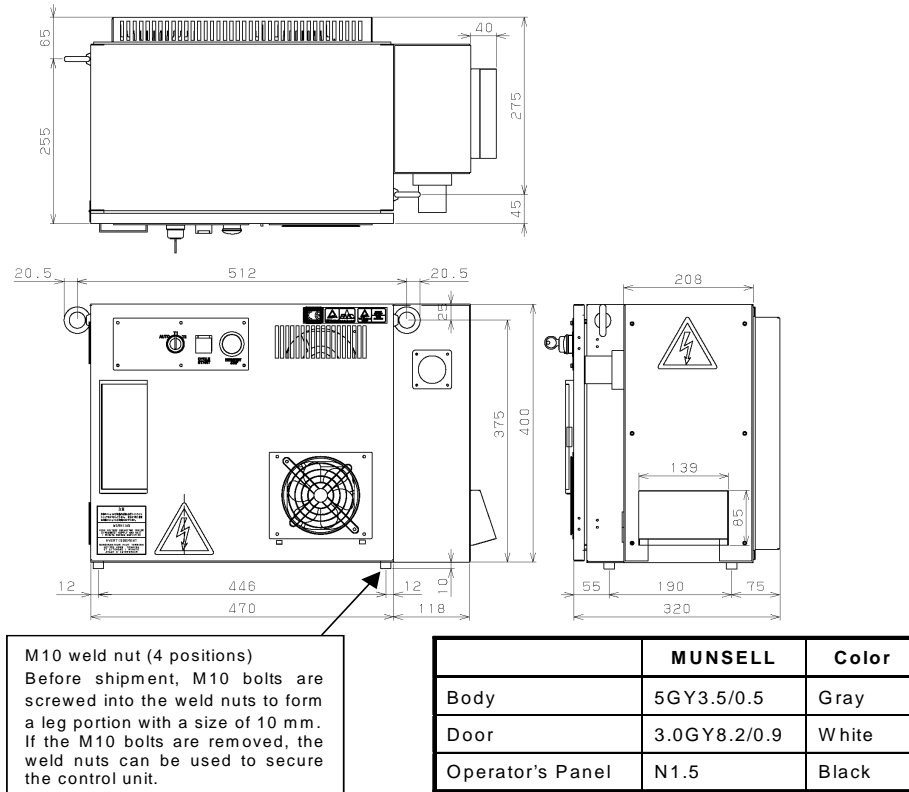


Fig.5.2.1(c) External dimension (LR Mate 200iC, M-1iA)

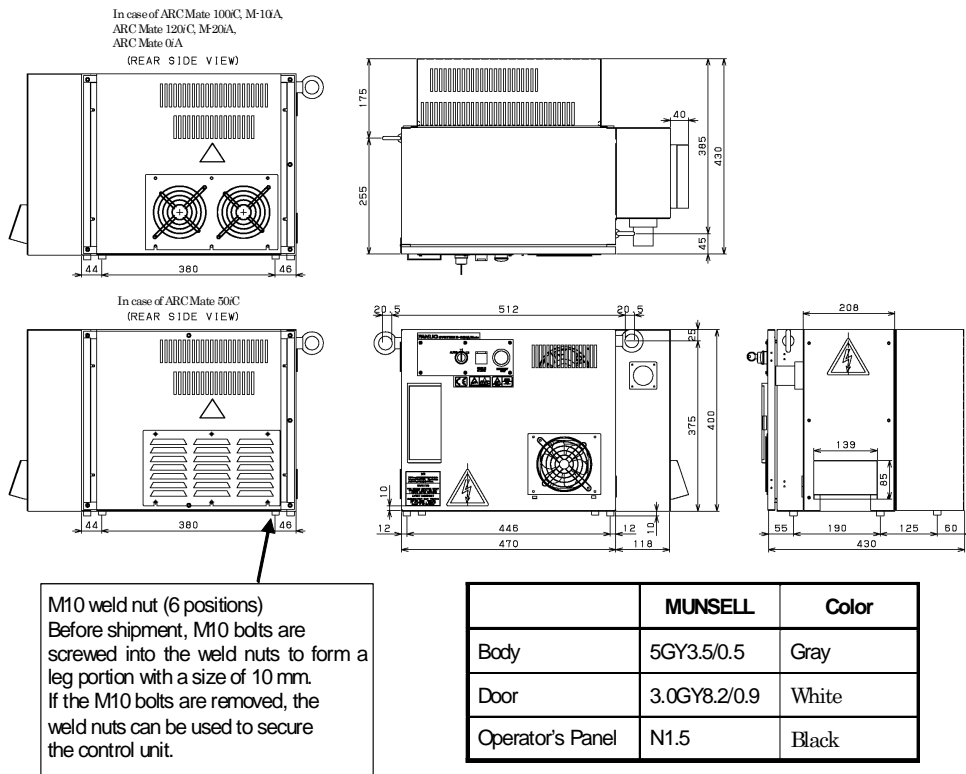


Fig.5.2.1(d) External dimension
(ARCMate 100iC, M-10iA, ARCMate 120iC, M-20iA, ARCMate 50iC, ARCMate 0iA)

5.3 MOUNTING METHOD OF TEACH PENDANT HOOK

Following is external dimension for Teach Pendant HOOK (Ordering specification: A05B-2550-K050).

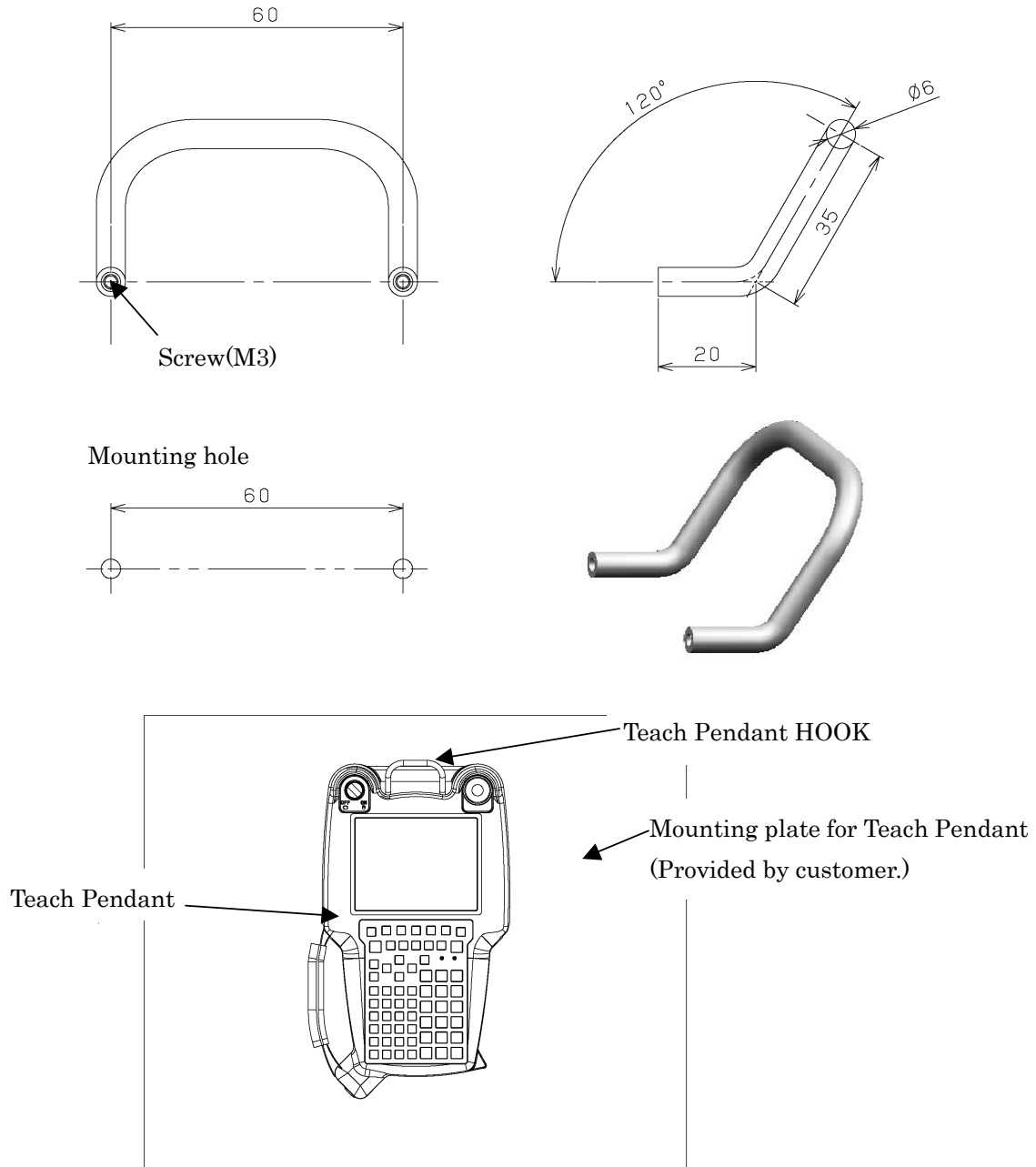


Fig.5.3 External dimension of Teach Pendant HOOK

5.4 INSTALLATION CONDITION

Item	Model	Specification/condition
Rated Voltage	LR Mate 200iC, M-1iA	200-230VAC +10% -15% 50/60Hz ±1Hz Single phase
	ARC Mate 100iC, M-10iA ARC Mate 120iC, M-20iA ARC Mate 50iC ARC Mate 0iA	200-230VAC +10% -15% 50/60Hz ±1Hz 3 phase
Tolerant fluctuation	All models	Tolerant voltage fluctuation: +10% -15% Tolerant frequency fluctuation: ±1Hz
Input power source capacity	M-1iA,	1.0KVA
	LR Mate 200iC, ARC Mate 50iC	1.2KVA
	ARC Mate 100iC, M-10iA ARC Mate 0iA	2.0KVA
	ARC Mate 120iC, M-20iA	3.0KVA
Average power consumption	M-1iA,	0.2KW
	LR Mate 200iC, ARC Mate 50iC	0.5KW
	ARC Mate 100iC, M-10iA ARC Mate 120iC, M-20iA ARC Mate 0iA	1.0KW
Permissible ambient temperature	All models	Operating 0°C to 45°C Storage, Transport -20°C to 60°C Temperature change 0.3°C/minute or less
Permissible ambient humidity	All models	Normal: 75%RH or less, no condensation Short period (less than 1 month): 95%RH or less, no condensation
Surrounding gas	All models	An additional protective provision is necessary if the machine is installed in an environment in which there are relatively large amounts of contaminants (dust, dielectric fluid, organic solvent, acid, corrosive gas, salt, etc.).
Installation Category	LR Mate 200iC, M-1iA	Installation Category III, Pollution Degree 3, IEC60664-1 and IEC61010-1
	ARC Mate 100iC, M-10iA ARC Mate 120iC, M-20iA ARC Mate 50iC ARC Mate 0iA	Installation Category II, Pollution Degree 3, IEC60664-1 and IEC61010-1 (NOTE2)
Vibration	All models	0.5G or less When using the robot in a location subject to serious vibration, consult with your FANUC sales representative.
Altitude	All models	Operating: Up to 1000m Non-operating: Up to 12000m
Ionized and non-ionized radiation	All models	A shielding provision is necessary if the machine is installed in an environment in which it is exposed to radiation (microwave, ultraviolet rays, laser beams, and/or X-rays).
Mass of control unit	All models	50kg

NOTE

- 1 The power rating indicated above is sufficient as the continuous rating. However, when the robot is rapidly accelerating, the instantaneous requirement may increase to several times the continuous rating.
If the acceleration/deceleration override (ACC) greater than 100% is set in the robot program, the extreme current may flow to the robot controller instantaneously and the input voltage of robot controller will drop.
In this case, if the supply voltage is decreased 10% or more per rated voltage, Power supply alarm, Move error excess alarm, DCLV alarm of servo amplifier may occur.
- 2 In case of connected with Input power source of Installation category III, set up isolated transformer between Input power source and controller.

5.5 ADJUSTMENT AND CHECKS AT INSTALLATION

Adjust the robot according to the following procedure at installation.

No.	Description
1	Visually check the inside and outside of the control unit.
2	Check the screw terminals for proper connection.
3	Check that the connectors and printed circuit boards are firmly connected.
4	Connect control unit and mechanical unit cables.
5	The breaker off and connect the input power cable.
6	Check the input power voltage.
7	Press the EMERGENCY STOP button on the operator panel and turn on the control unit.
8	Check the interface signals between control unit and robot mechanical unit.
9	Check the parameters. If necessary, set them.
10	Release the EMERGENCY STOP button on the operator panel. Turn on the controller.
11	Check the movement along each axis in manual jog mode.
12	Check the end effector interface signals.
13	Check the peripheral device control interface signals.

5.6 RESETTING OVERTRAVEL AND EMERGENCY STOP AT INSTALLATION

An overtravel and emergency stop occur when the robot is operated for the first time after it is installed and the mechanical and control units are wired. This section describes how to reset the overtravel and emergency stop.

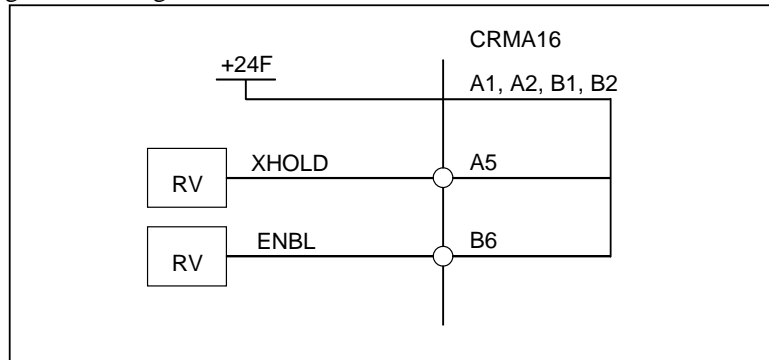
Remove the red plate fastening the swiveling axis beforehand.

The J2 and J3 axes are pressed against the hard stops at shipment. Therefore, an overtravel alarm occurs when the power is turned on after installation.

The robot can also be in an emergency stop state if the peripheral device control interface is not connected.

5.6.1 Peripheral Device Interface Processing

Take the following actions if signals *HOLD and ENBL are not used.



5.6.2 Resetting Overtravel

- 1) Select [OT release] on the overtravel release screen to release each robot axis from the overtravel state.
- 2) Hold down the shift key, and press the alarm release button to reset the alarm condition.
- 3) Still hold down the shift key, and jog to bring all axes into the movable range.

5.6.3 How to Disable/Enable HBK

- 1) Press [MENUS] on the teach pendant.
- 2) Select [NEXT].
- 3) Select [SYSTEM].
- 4) Press "F1" (TYPE) on the teach pendant.
- 5) Select "Config" to disable/enable HBK.

Status	Hand Broken enable/disable setting	HBK (*1)	HBK detection	Robot operation	Message
1	Enable	CLOSE	Yes	Possible	None
2	Enable	OPEN	Yes	Impossible	SRVO-006
3	Disable	CLOSE	Yes (*2)	Possible	None
4	Disable	OPEN	No	Possible	At cold start, SRVO-300

NOTE

- 1 Robot end effector connector

CLOSE

OPEN
- 2 The moment the HBK circuit is closed, HBK detection becomes enabled. When the HBK circuit is opened again, alarm "Servo 300" or "Servo 302" occurs, causing the robot to stop.
- 3 If the power is turned off and on again under the condition stated in *2, status 4 is entered, so the alarm condition is removed.

5.6.4 How to Disable/Enable Pneumatic Pressure Alarm (PPABN)

- 1) Press [MENUS] on the teach pendant.
- 2) Select [NEXT].
- 3) Select [SYSTEM].
- 4) Press "F1" (TYPE) on the teach pendant.
- 5) Select "Config" to disable/enable PPABN.

APPENDIX

A TOTAL CONNECTION DIAGRAM

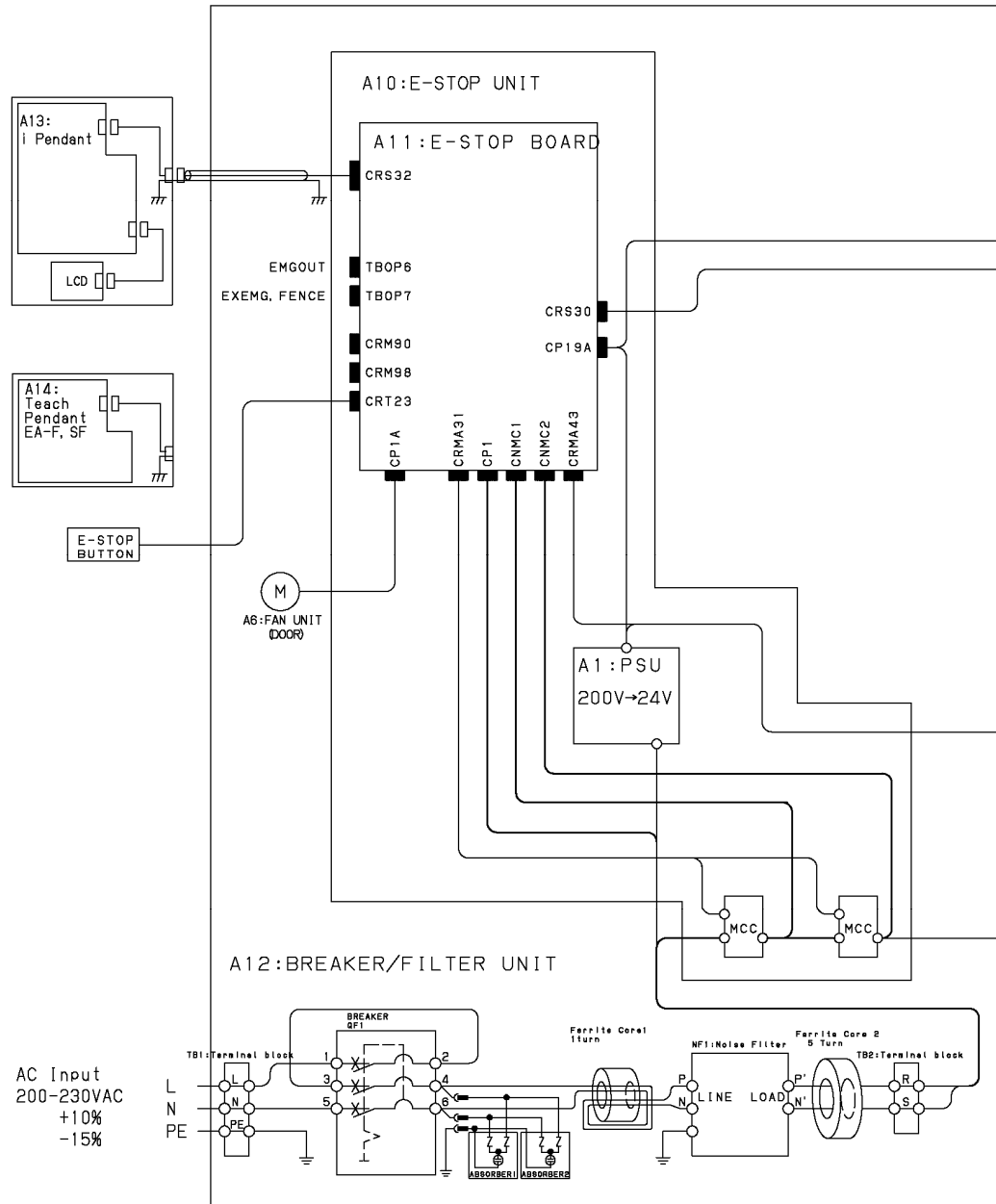
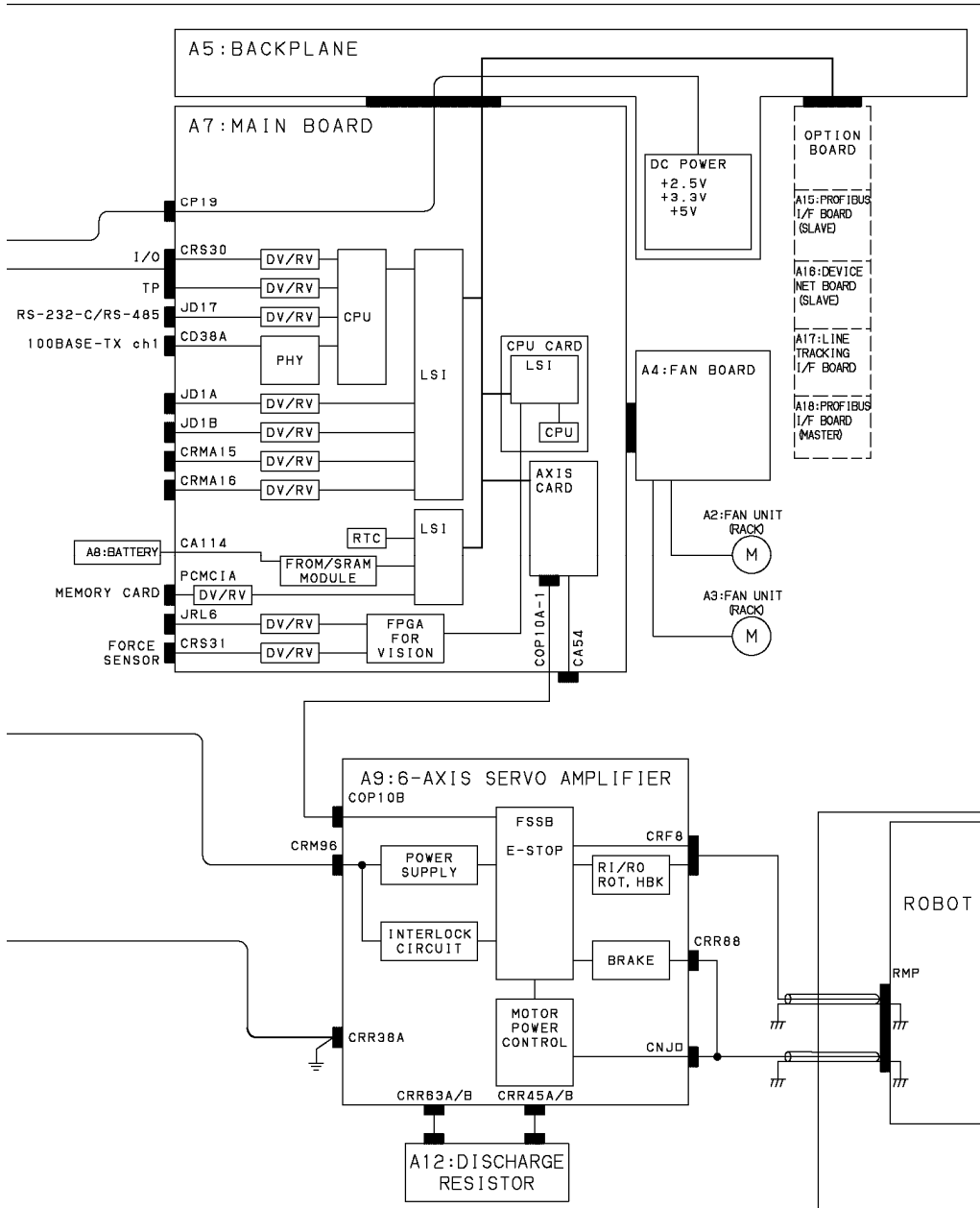


Fig.A (a) System block diagram (LR Mate 200iC, M-1iA)



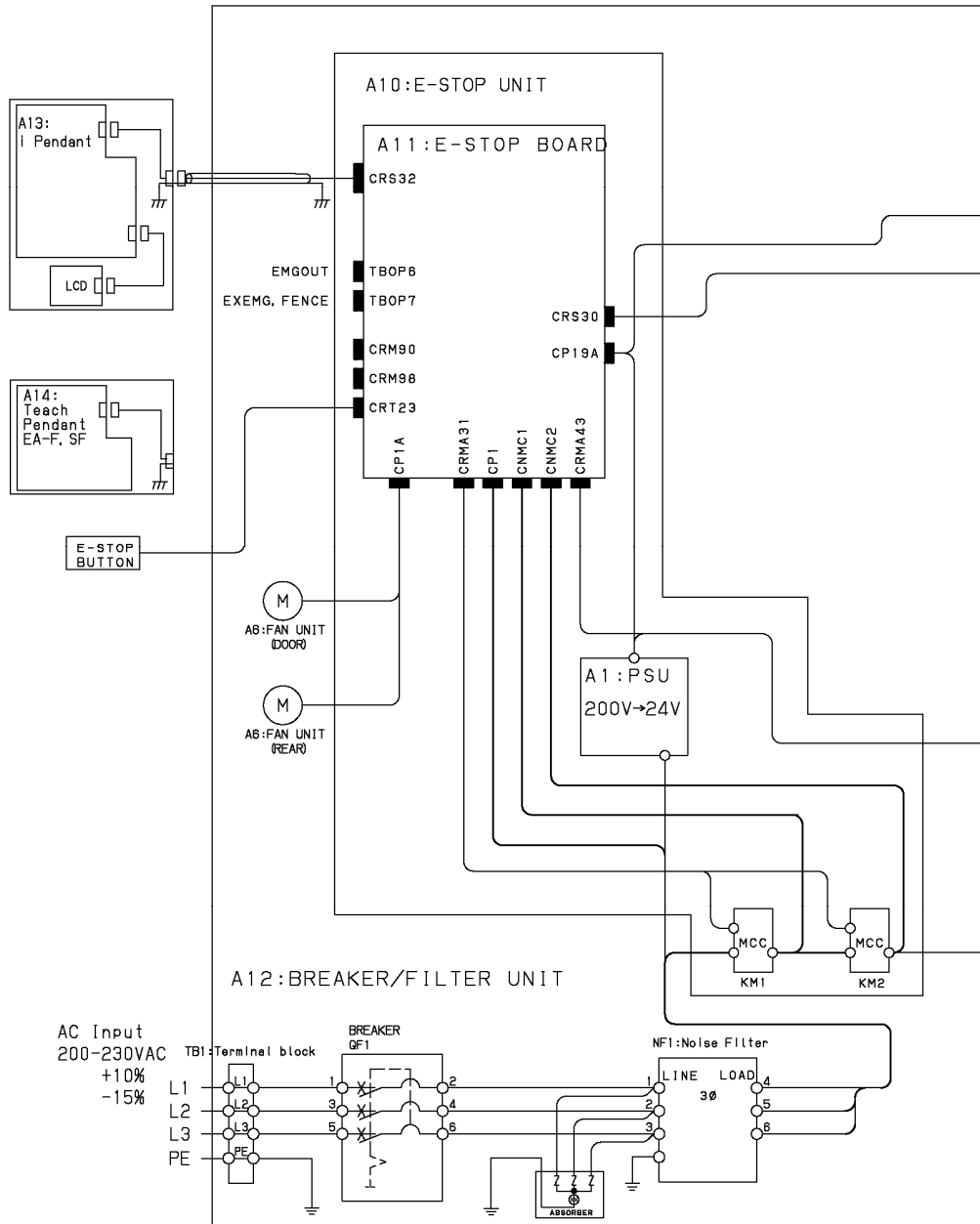
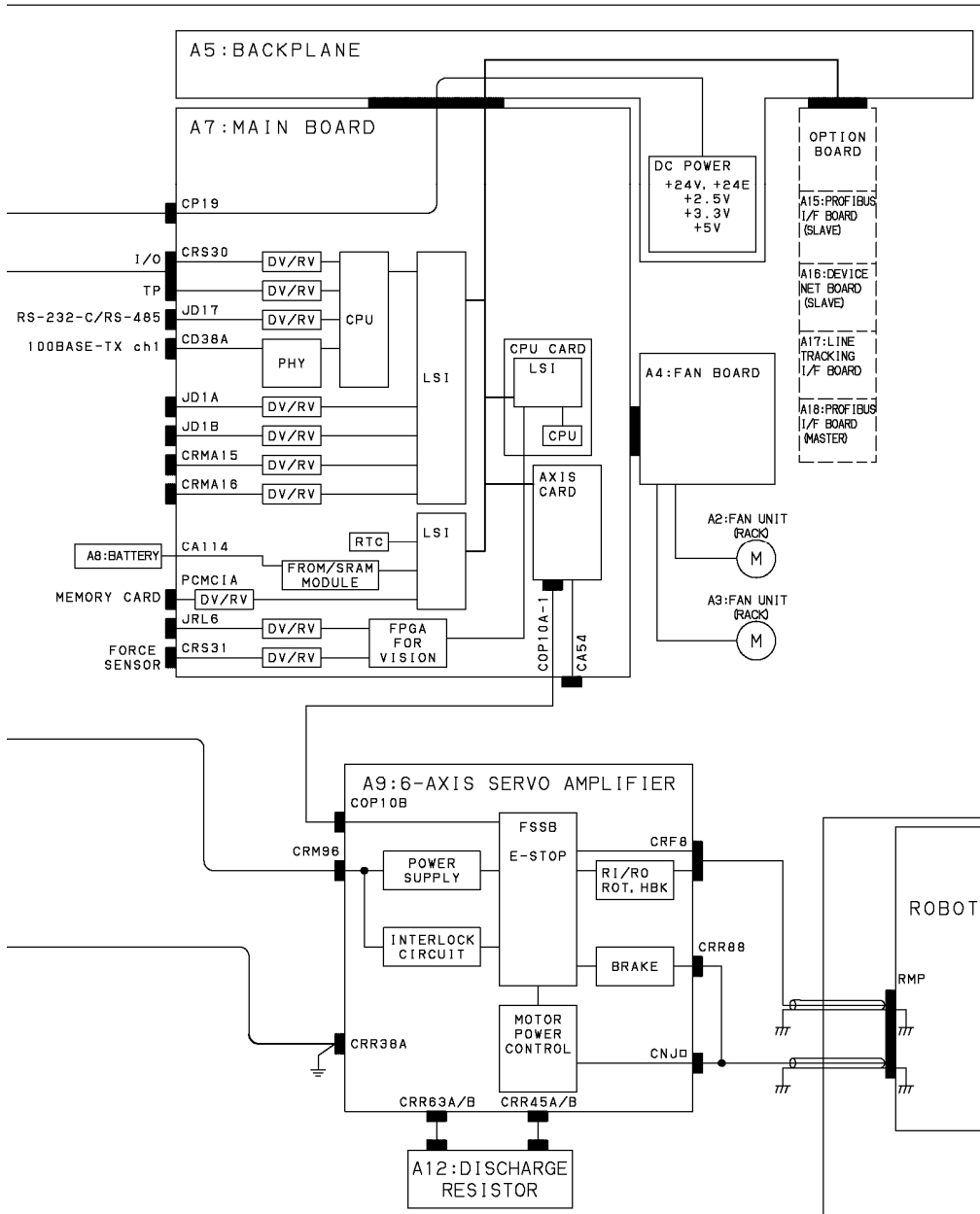
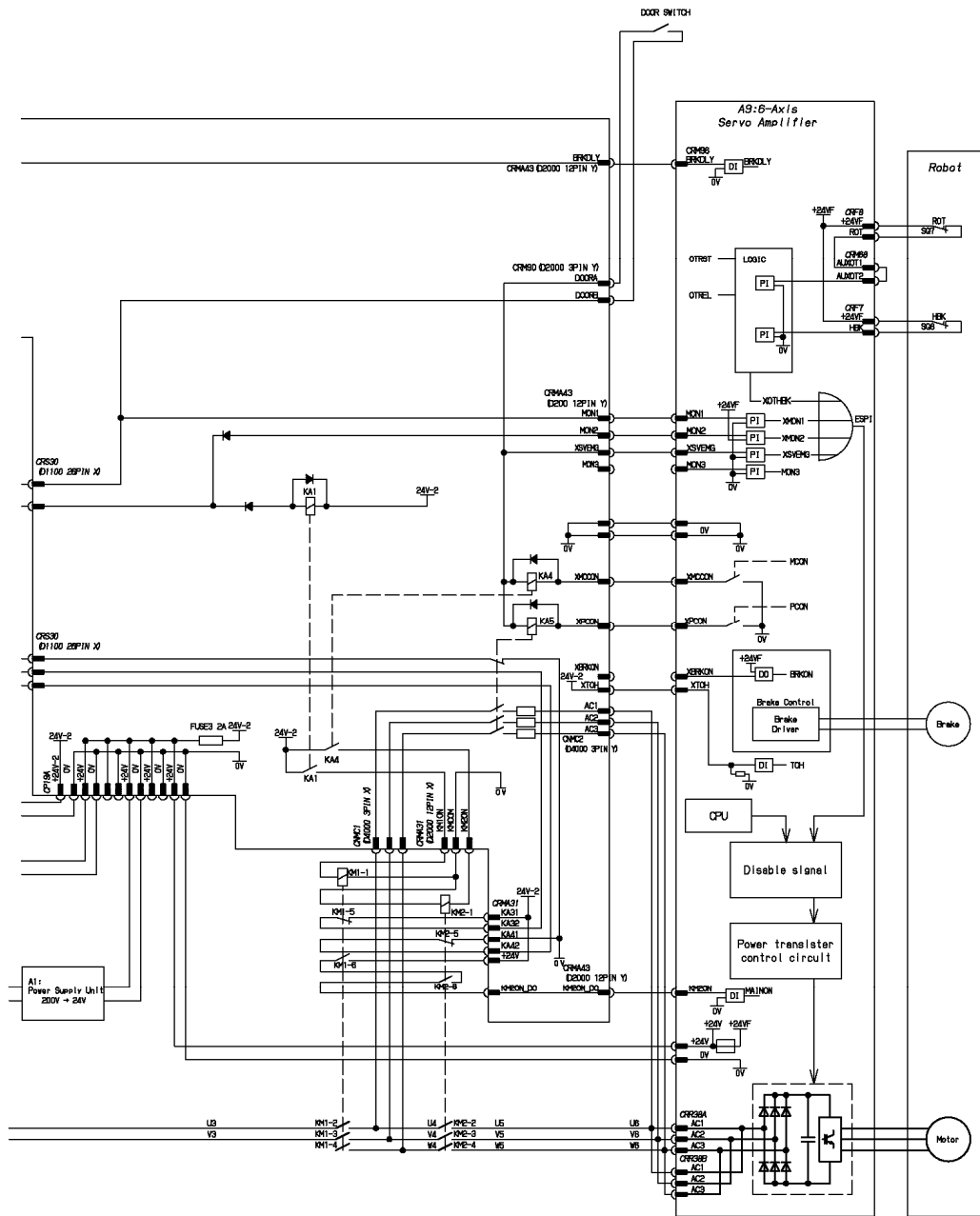


Fig.A (b) System block diagram
(ARC Mate 100iC,M-10iA, ARC Mate 120iC,M-20iA, ARC Mate 50iC, ARC Mate 0iA)





E-STOP CIRCUIT <R-30iA Mate:ARC Mate 100iC>
Dual check safety

DI: Simple DI
PI: Photo coupler DI
Not showing the diodes to protect from reverse electric power.

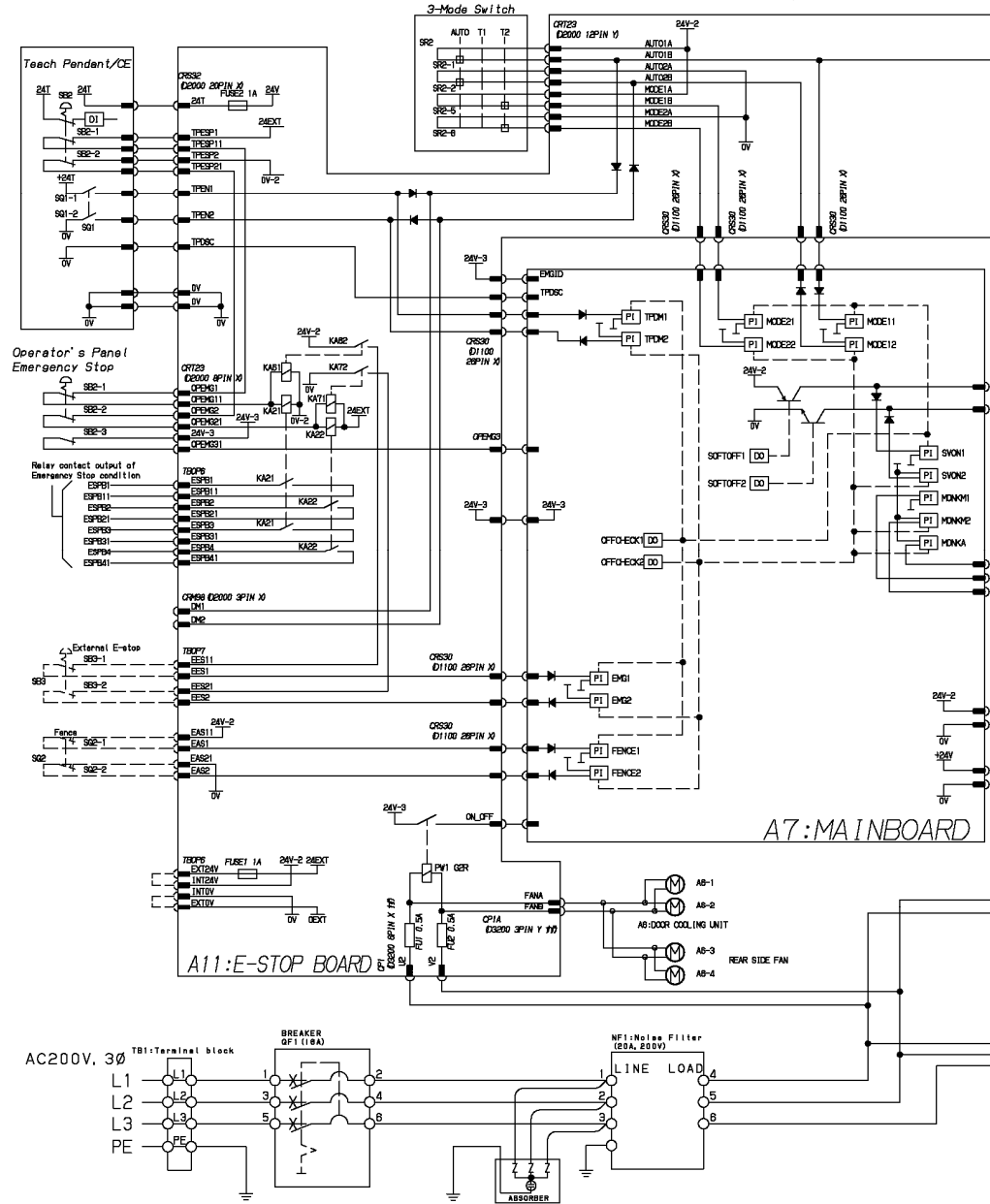


Fig.A (d) Emergency stop circuit diagram
(ARC Mate 100iC, M-10iA, ARC Mate 120iC, M-20iA, ARC Mate 50iC, ARC Mate 0iA)

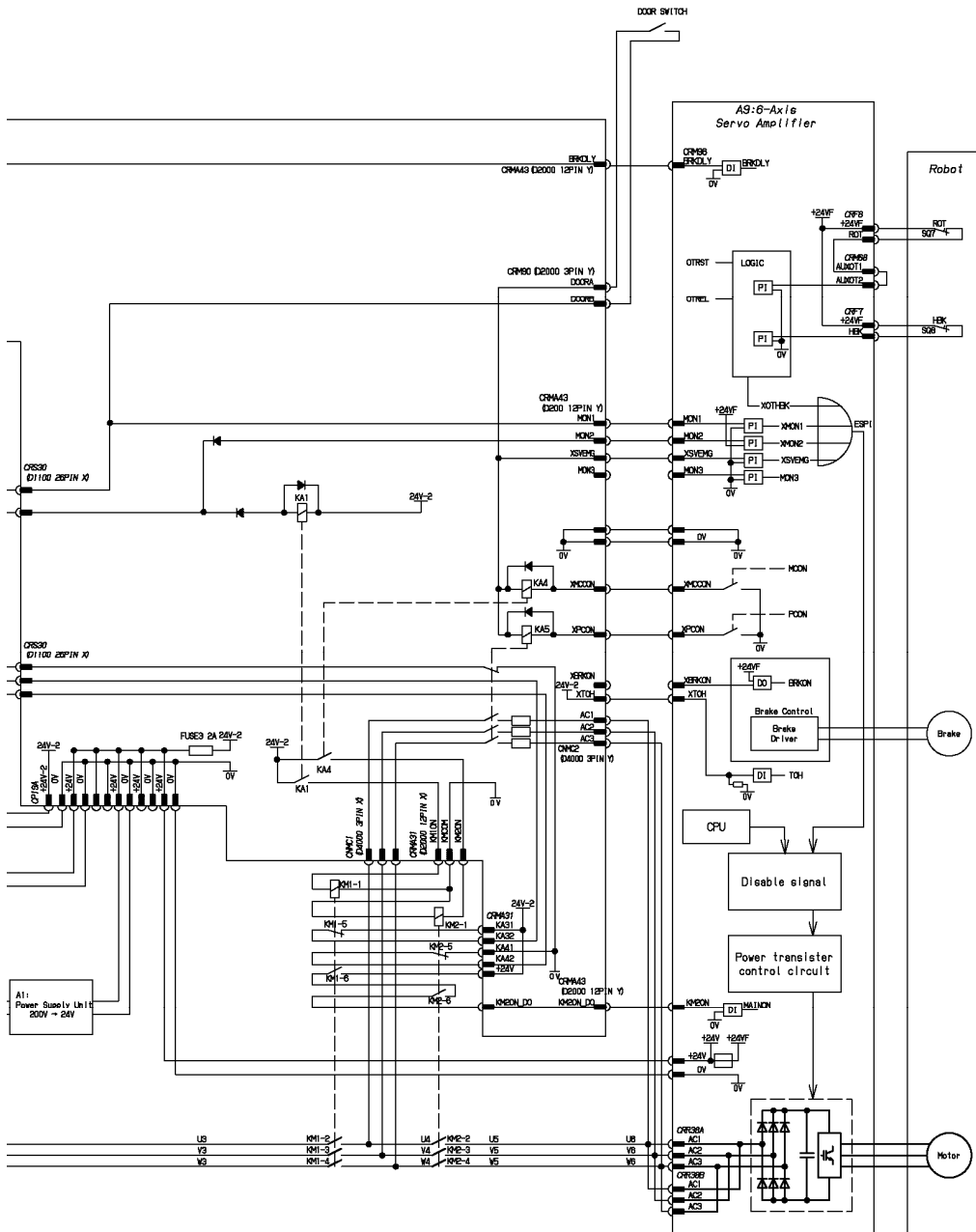
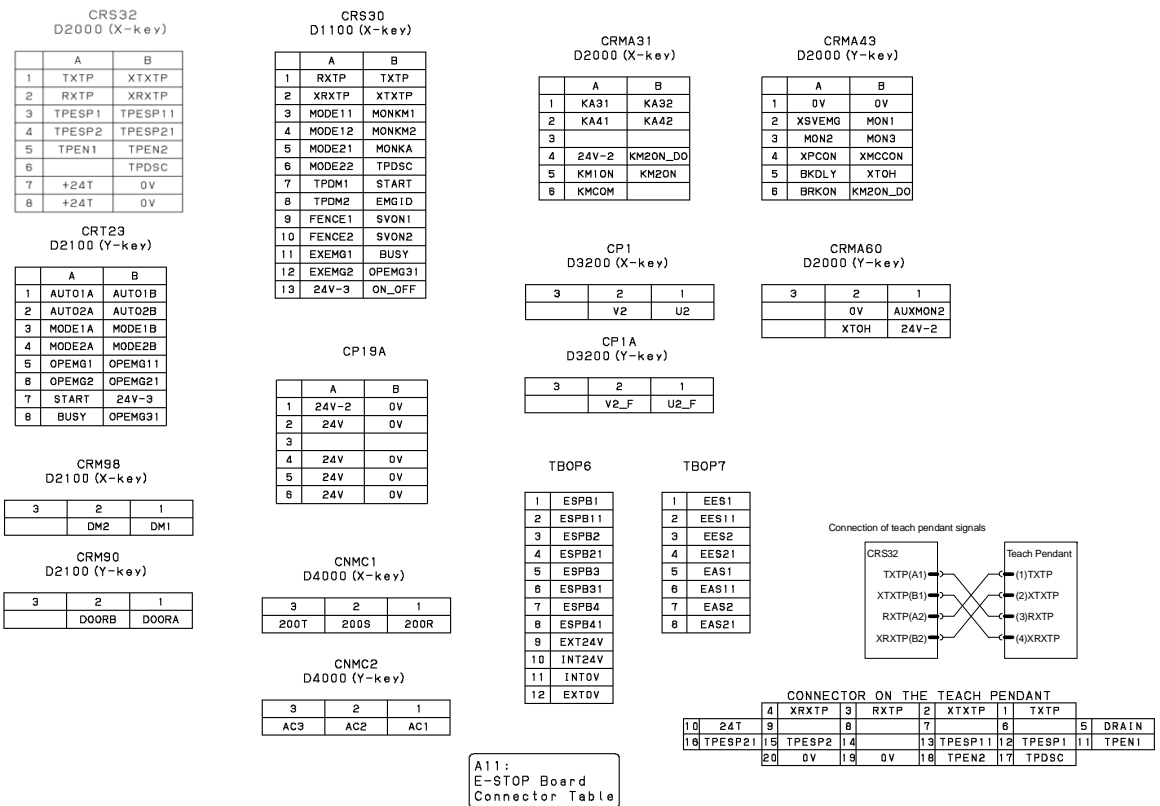


Fig.A (e) Emergency stop board connector table



M-JD1A/S-JD1B
I/O Link (1 CH)
(Main Board I/O Device)

1	SLINA	11	0V
2	XSLINA	12	0V
3	SLOUTA	13	0V
4	XSLOUTA	14	0V
5	SLC1IN	15	0V
6	XSLC1IN	16	0V
7	SLC1OUT	17	
8	XSLC1OUT	18	5V
9	5V	19	24V-3
10	24V-3	20	5V

S-JD1A
I/O Link (2 CH)
(Main Board I/O Device)

1	SLINB	11	0V
2	XSLINB	12	0V
3	SLOUTB	13	0V
4	XSLOUTB	14	0V
5	SLC2IN	15	0V
6	XSLC2IN	16	0V
7	SLC2OUT	17	
8	XSLC2OUT	18	5V
9	5V	19	24V-3
10	24V-3	20	5V

JD17
RS-232-C & RS-485
(Main Board - Serial Device)

1	RD	11	SD
2	SG	12	SG
3	DR	13	ER
4	SG	14	SG
5	CS	15	RS
6	SG	16	SG
7	RX485D	17	TX485D
8	XR485D	18	XTX485D
9		19	+24V
10	+24V	20	

CRS30
TP Signal/E-stop Signal
(Main Board - E-stop Board)

	A	B
1	RXTP	TXTP
2	XRTP	XTXTP
3	MODE11	MONKM1
4	MODE12	MONKM2
5	MODE21	MONKA
6	MODE22	TPOFF
7	NTED11	START
8	NTED2	EMG1D
9	FENCE1	SVON1
10	FENCE2	SVON2
11	EXEMG1	BUSY
12	EXEMG2	OPEMG3
13	24V-3	ON_OFF

CA115A
INVERTER

1		7	24V-3
2		8	0V
3		9	FALM1
4		10	
5		11	
6		12	

CA114
BATTERY

3	2	1
	0V	BAT

JRL6
Video Interface

1	XVD	11	
2	0V	12	0V
3	XHD	13	
4	0V	14	0V
5	XTRIG	15	CAMD11
6	0V	16	0V
7	VIDEOIN	17	CAMD10
8	0V	18	CAMD00
9		19	P_12V
10	0V	20	CAMD01

CP19
DC24V

3	2	1
24V-2	IN0V	IN24V

CRS31
Force Sensor

1	SDATA	5	24E
2	XSDATA	6	0V
3	CAMD02	7	
4	CAMD03	8	

CD38A
Ethernet 100Base-TX
(Main Board - Network)

1	TX+
2	TX-
3	RX+
4	
5	
6	RX-
7	
8	

CRMA15
DI/DO

	A	B
1	24F	24F
2	24F	24F
3	SDICOM1	SDICOM2
4	0V	0V
5	DI101	DI102
6	DI103	DI104
7	DI105	DI106
8	DI107	DI108
9	DI109	DI110
10	DI111	DI112
11	DI113	DI114
12	DI115	DI116
13	DI117	DI118
14	DI119	DI120
15	D101	D102
16	D103	D104
17	D105	D106
18	D107	D108
19	0V	0V
20	D0SRC1	D0SRC1

CRMA16
DI/DO

	A	B
1	24F	24F
2	24F	24F
3	SDICOM3	
4	0V	0V
5	DI121	DI122
6	DI123	DI124
7	DI125	DI126
8	DI127	DI128
9		
10	D0109	D0110
11	D0111	D0112
12	D0113	D0114
13	D0115	D0116
14	D0117	D0118
15	D0119	D0120
16	D0121	D0122
17	D0123	D0124
18		
19	0V	0V
20	D0SRC2	D0SRC2

A3:
MAIN BOARD

Fig.A (f) Main board connector table

Fig.A (g) Servo amplifier connector table

	A	B	C
1	XPRQJ1	PRQJ1	5V
2	XPRQJ2	PRQJ2	5V
3	XPRQJ3	PRQJ3	5V
4	XPRQJ4	PRQJ4	5V
5	XPRQJ5	PRQJ5	5V
6	XPRQJ6	PRQJ6	5V
7	S+	S-	0V
8	R11	R12	0V
9	R13	R14	0V
10	R15	R16	0V
11	R17	R18	0V
12	R19	RO1	0V
13	RO2	RO3	
14	RO4	RO5	
15	RO6	RO7	
16	RO8	XHBK	
17	24VF	XROT	
18	24VFIN	0V	

1	FSSB1
2	FSSB2

1	FSSB1
2	FSSB2

A1	24V	B1	24V
A2	0V	B2	0V
A3	XSVEMG	B3	MON1
A4	MON2	B4	MON3
A5	XPCHON	B5	XMCCON
A6		B6	XTON
A7	BRKDLV	B7	KM2ON
A8	XBRKON	B8	XOTHBK

A1	XBRKRLS2	B1	24VF
A2	XBRKRLS3	B2	0V
A3	XBRKRLS4	B3	XFUSEALM
A4	GUNCHG	B4	XSVEMG
A5	KM3ON	B5	OTHBK
A6		B6	

A1	S2+
A2	S2-
A3	0V

1	DCP
2	DCP
3	DCN
4	DCN

A1	24VS	B1	24VS
A2	0V	B2	0V
A3		B3	
A4	XESP2	B4	

1	2	3
J1U1	J1V1	J1W1

1	2	3
J2U1	J2V1	J2W1

1	2	3
J3U1	J3V1	J3W1

1	2	3
J4U1	J4V1	J4W1

1	2	3
J5U1	J5V1	J5W1

1	2	3
J6U1	J6V1	J6W1

1	2	3
J1G1	J2G1	J3G1

1	2	3
J4G1	J5G1	J6G1

1	DCRA1
2	DCRA2

1	DCRB1
2	DCRB2

1	PE
2	AC1
3	AC2
4	AC3

1	DCTHA1
2	DCTHA2

1	DCTHB1
2	DCTHB2
3	DCEXSTB

A1	BK (J7)	B1	BK (J8)
A2		B2	BK
A3	BKC	B3	BKC

H002 is mounted

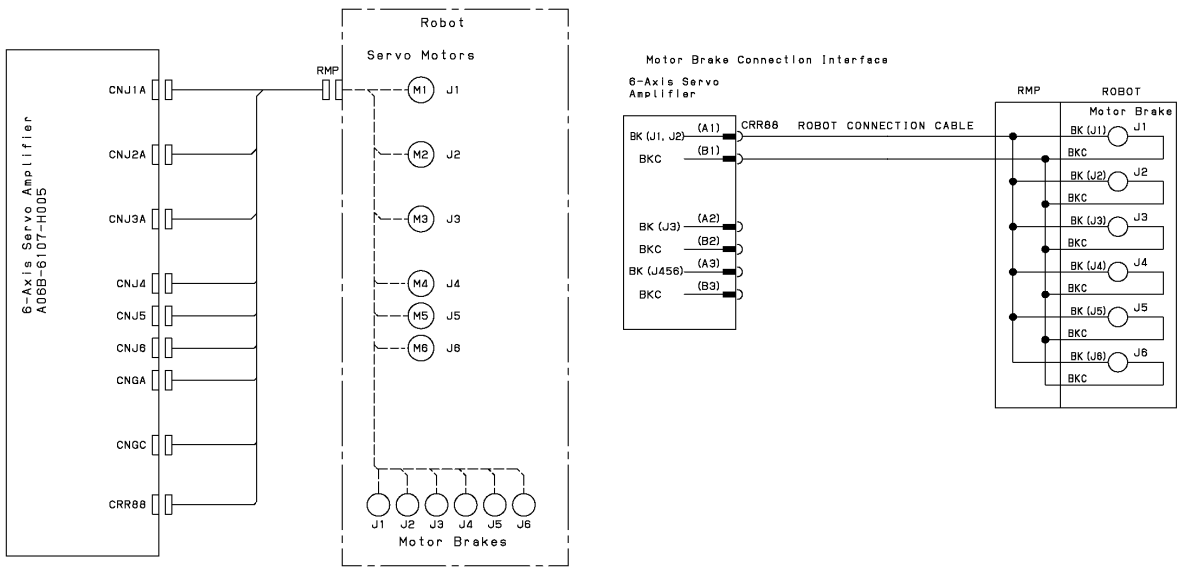


Fig.A (h) Motor power connection (LR Mate 200iC(6-Axis), ARC Mate 50iC(6-Axis), M-1iA/0.5A)

Motor Power Connection
LR Mate 200iC, ARC Mate 50iC, M-1iA/0.5A

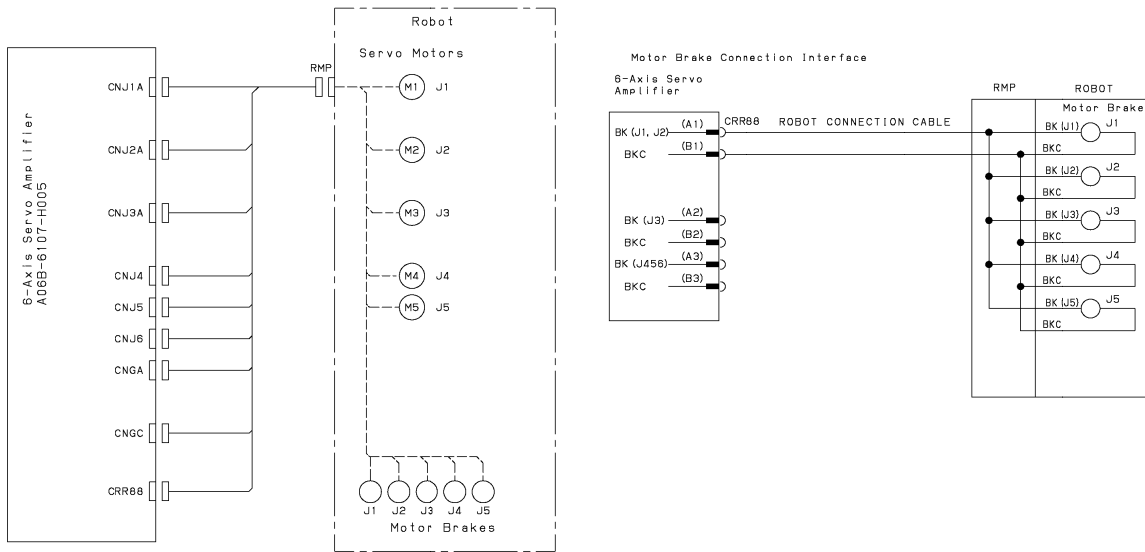


Fig.A (I) Motor power connection (LR Mate 200iC(5-Axis))

Motor Power Connection
LR Mate 200iC (5-Axis)

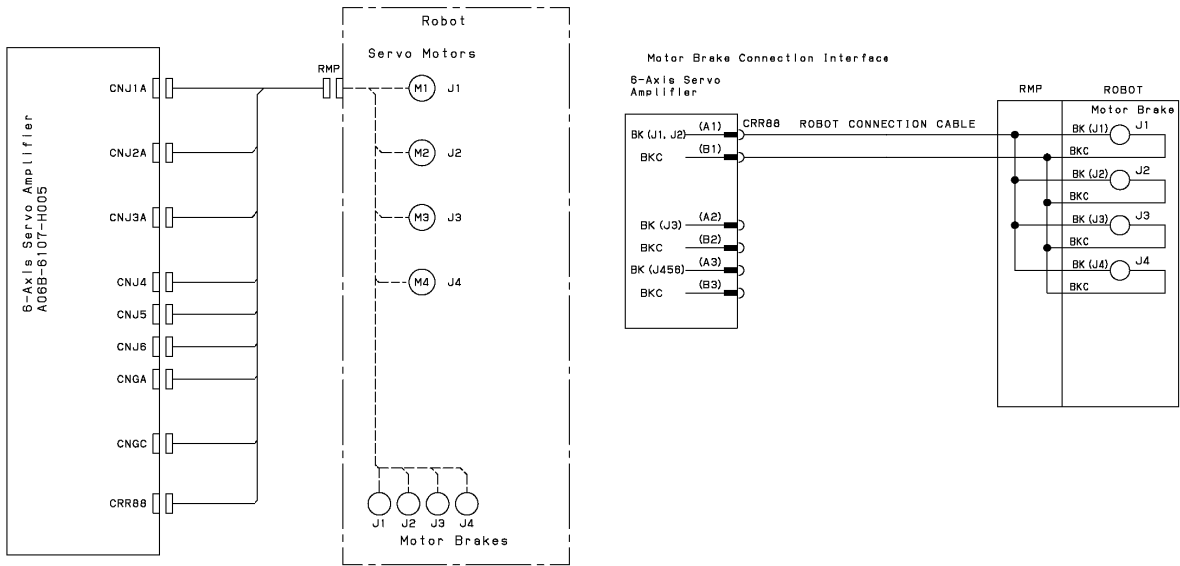


Fig.A (I) Motor power connection (M-1iA/0.5S(4-Axis))

Motor Power Connection
M-1iA/0.5S (4-Axis)

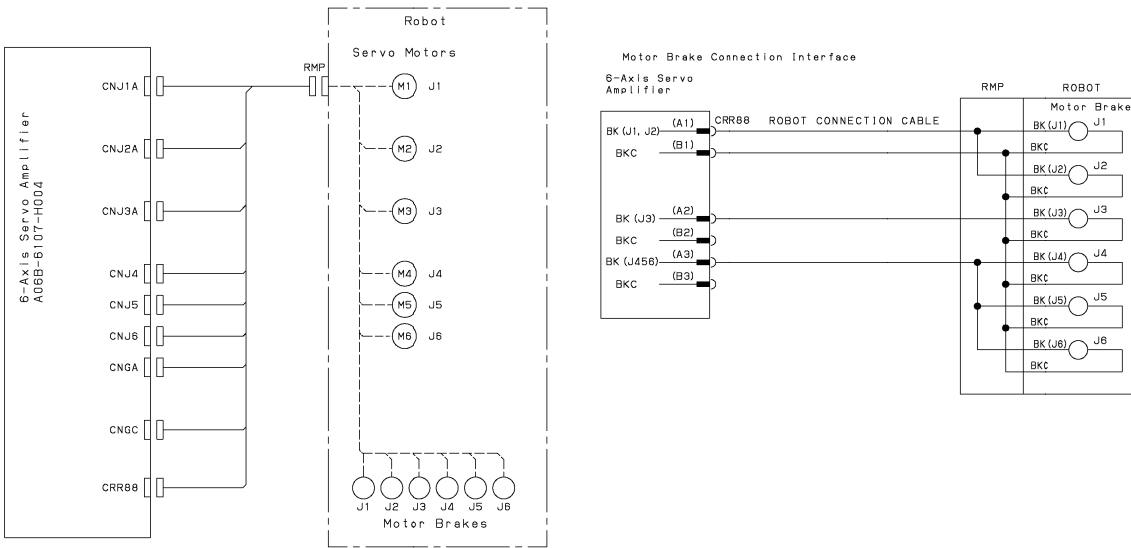


Fig.A (k) Motor power connection (ARC Mate 100iC, M-10iA, ARC Mate 0iA)

Motor Power Connection
ARC Mate 100iC, M-10iA

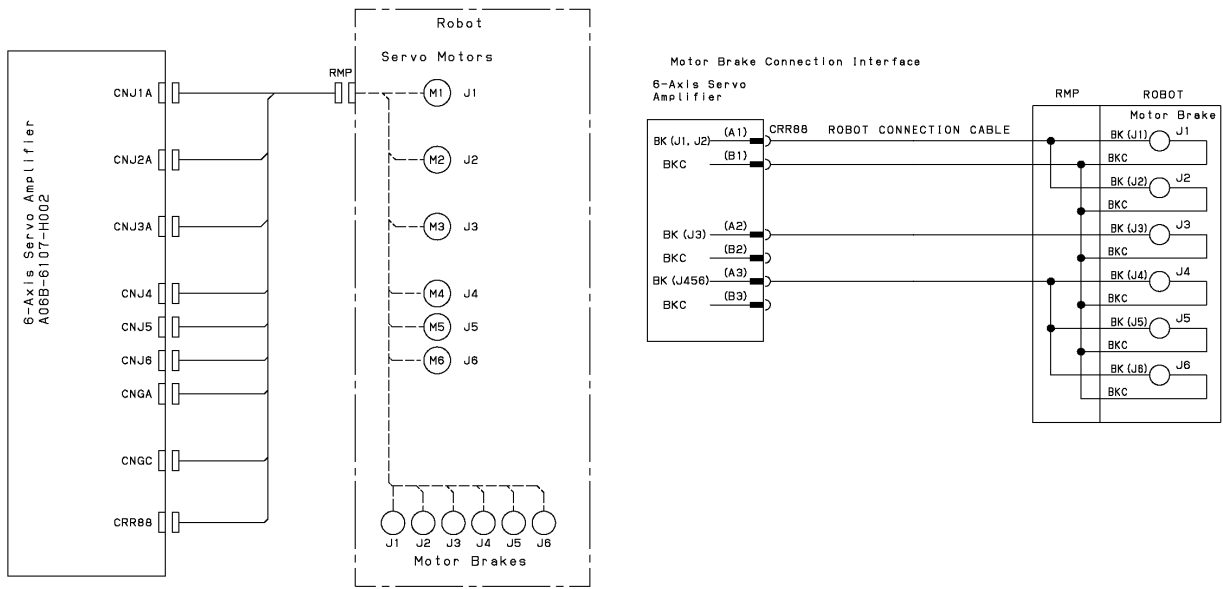


Fig.A (I) Motor power connection (ARC Mate 120iC, M-20iA)

Motor Power Connection
ARC Mate 120iC, M-20iA

RMP (FOR ARC Mate 100iC, M-101A, ARC Mate 120iC, M-201A)

1	BK (J1)	13	BK (J2)	25	BK (J3)	37	BK (J4)	49	BK (J5)	61	BK (J6)
2	J1U1	14	J2U1	26	J3U1	38		50		62	BKC
3	J1V1	15	J2V1	27	J3V1	39	J4U1	51	J5U1	63	J6U1
4	J1W1	16	J2W1	28	J3W1	40	J4V1	52	J5V1	64	J6V1
5	J1G1	17	J2G1	29	J3G1	41	J4W1	53	J5W1	65	J6W1
6	XROT	18	24VF	30	XHBK	42	J4G1	54	J5G1	66	J6G1
7	R11	19	R12	31	R13	43	R14	55	R15	67	OV
8	RO1	20	RO2	32	RO3	44	RO4	56	RO5	68	R16
9	R17	21	R18	33	RO7	45	RO8	57	XPPABN	69	RO6
10	5V (J1, J2)	22	5V (J3, J4)	34	5V (J5, J6)	46	OV (J1, J2)	58	OV (J3, J4)	70	OV (J5, J6)
11	PRQJ1	23	PRQJ2	35	PRQJ3	47	PRQJ4	59	PRQJ5	71	PRQJ6
12	XPRQJ1	24	XPRQJ2	36	XPRQJ3	48	XPRQJ4	60	XPRQJ5	72	XPRQJ6

RMP (FOR LR Mate 200iC, M-11A, ARC Mate 50iC)

1	BK (J1)	13	BK (J2)	25	BK (J3)	37	BK (J4)	49	BK (J5)	61	BK (J6)
2	BKC	14	BKC	26	BKC	38	BKC	50	BKC	62	BKC
3	J1U1	15	J2U1	27	J3U1	39	J4U1	51	J5U1	63	J6U1
4	J1V1	16	J2V1	28	J3V1	40	J4V1	52	J5V1	64	J6V1
5	J1W1	17	J2W1	29	J3W1	41	J4W1	53	J5W1	65	J6W1
6	J1G1	18	J2G1	30	J3G1	42	J4G1	54	J5G1	66	J6G1
7	XROT	19	24VF (OT)	31	XHBK	43	24VF	55	OV	67	OV
8	R11	20	R12	32	R13	44	R14	56	R15	68	R16
9	RO1	21	RO2	33	RO3	45	RO4	57	RO5	69	RO6
10	5V (J1)	22	5V (J2, J3)	34	5V (J4,5,6)	46	OV (J1)	58	OV (J2, J3)	70	OV (J4,5,6)
11	PRQJ1	23	PRQJ2	35	PRQJ3	47	PRQJ4	59	PRQJ5	71	PRQJ6
12	XPRQJ1	24	XPRQJ2	36	XPRQJ3	48	XPRQJ4	60	XPRQJ5	72	XPRQJ6

FigA (m) Mechanical unit interface
 (In case of ARC Mate 100iCe, M-101Ae, R1/RO, R16/RO, HBK, ROT are not available)
 (In case of ARC Mate 01A, R12-8/RO2-8 are not available)

B BRAKE RELEASE UNIT

B.1 SAFETY PRECAUTIONS

WARNING

Support the robot arm by mechanical means to prevent it from falling down or rising up when brake is released. Before using the brake release unit, read the Operator's manual of the robot that tries to release the brake.

Confirm that the robot is fixed tightly to the floor to prevent the falling down and unexpected movement of robot.

Confirm that the outlet with earth is used for the power supply of brake release unit and earth of brake release unit is surely connected to earth of power supply. There is danger of getting an electric shock if earth is not connected.

B.2 CONFIRMATIONS BEFORE OPERATION

Confirm the followings before operation.

- (1) Confirm the exterior of the brake release unit and the power cable. Do not use it when there are damages in the unit and the cable.
- (2) Confirm that the power supply of the robot controller is disconnected.
- (3) There are two types of brake release units according to the input voltage as shown in Table B.2 (a). Confirm the input voltage of the unit to refer to the input voltage label put to the unit (Fig. B.5 (a)).
- (4) Confirm that the voltage of power supply before connecting the power supply to the brake release unit. There is possibility to give the damaging to the brake or the brake release unit when the incorrect power supply is connected to the unit.

Table B.2 (a) Specification of brake release unit

Brake release unit	Remarks
Brake release unit (AC 100V)	Input voltage AC100-115V, single phase
Brake release unit (AC 200V)	Input voltage AC200-240V, single phase

- (5) The brake release unit connection cable is different in each robot. Confirm the cable specification corresponding to the robot referring to Table B.2 (b).

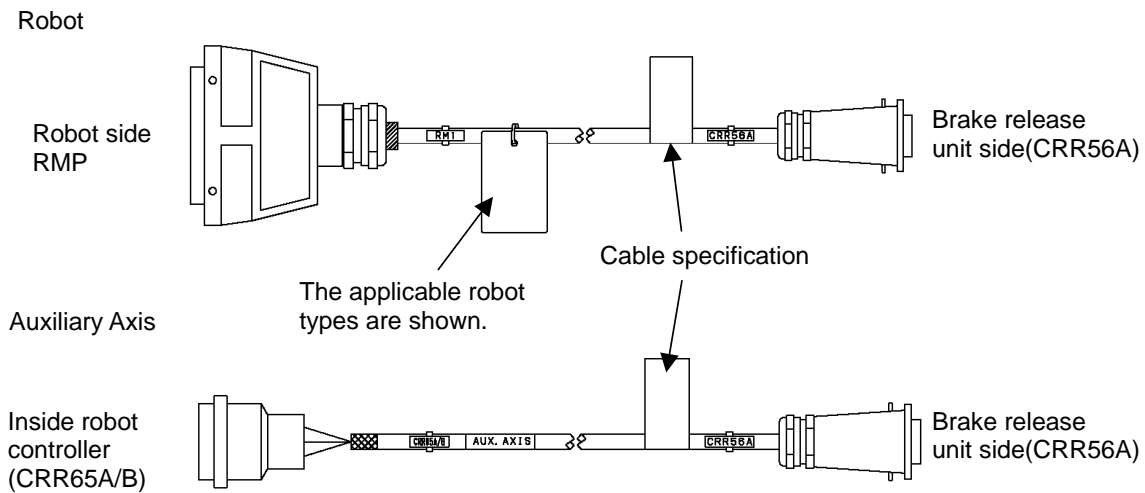


Fig.B.2 Brake release unit connection cable

Table B.2 (b) Specification of brake release unit connection cable

Applicable robot types	Specification of cable
LR Mate 200iC, ARC Mate 50iC, M-1iA	A660-2006-T474
ARC Mate 100iC, M-10iA, ARC Mate 120iC, M-20iA, ARC Mate 0iA	A660-2006-T881
Auxiliary AXIS	A660-2005-T711

B.3 OPERATION

In case of operating to the robot

Operate the brake release unit according to the following procedures.

- (1) Support the robot arm by mechanical means to prevent it from falling down or rising up when brake is released. Refer to the Operator's manual for each robot.
- (2) Connect the Brake Release Unit connection cable to Brake Release Unit.
- (3) Disconnect the RMP connector from Robot, and connect the Brake Release Unit connection cable to the Robot. Keep the connection of Robot connection cable except RMP cable.
- (4) Connect the power cable of Brake release unit to power supply.
- (5) Press and hold the deadman switch in the middle position.
- (6) Press the brake switch '1'..'6' according to the axis that tries to release the brake, then brake will be released. (Refer to Table B.3) Two axes or more cannot be operated at the same time.

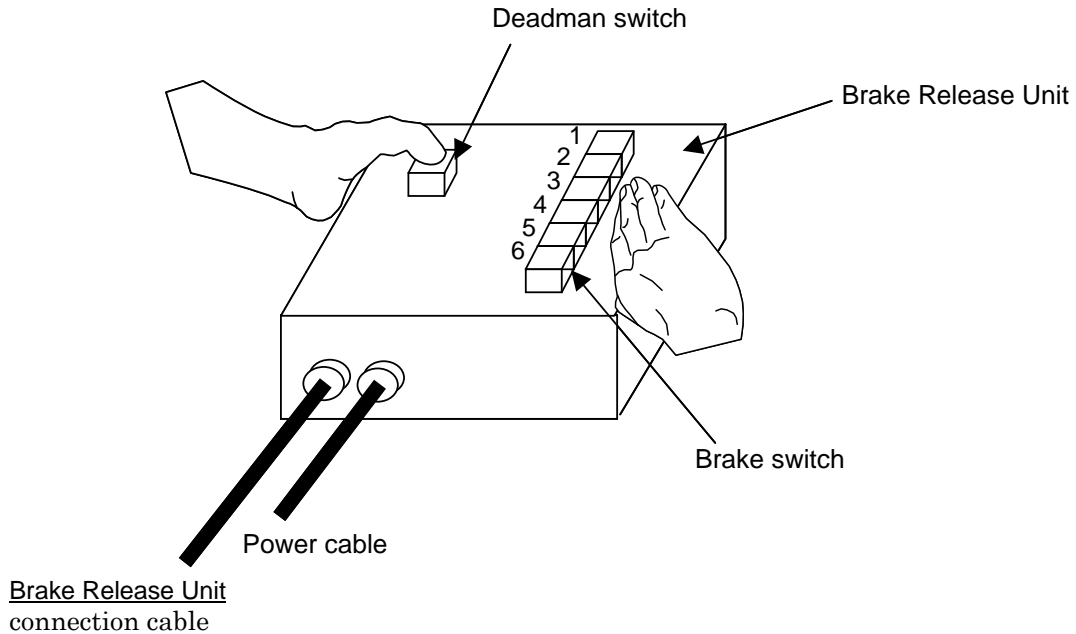


Fig.B.3 (a) Brake release unit

Table B.3 The relation between brake switch and robot axis

Robot	Brake switch					
	1	2	3	4	5	6
LR Mate 200iC(6 axes), ARC Mate 0iA, ARC Mate 100iC, M-10iA, ARC Mate 50iC ARC Mate 120iC, M-20iA, M-1iA/0.5A(6 axes)	J1	J2	J3	J4	J5	J6
LR Mate 200iC(5 axes)	J1	J2	J3	-	J4	J5
M-1iA/0.5S(4 axes)	J1	J2	J3	J4	-	-

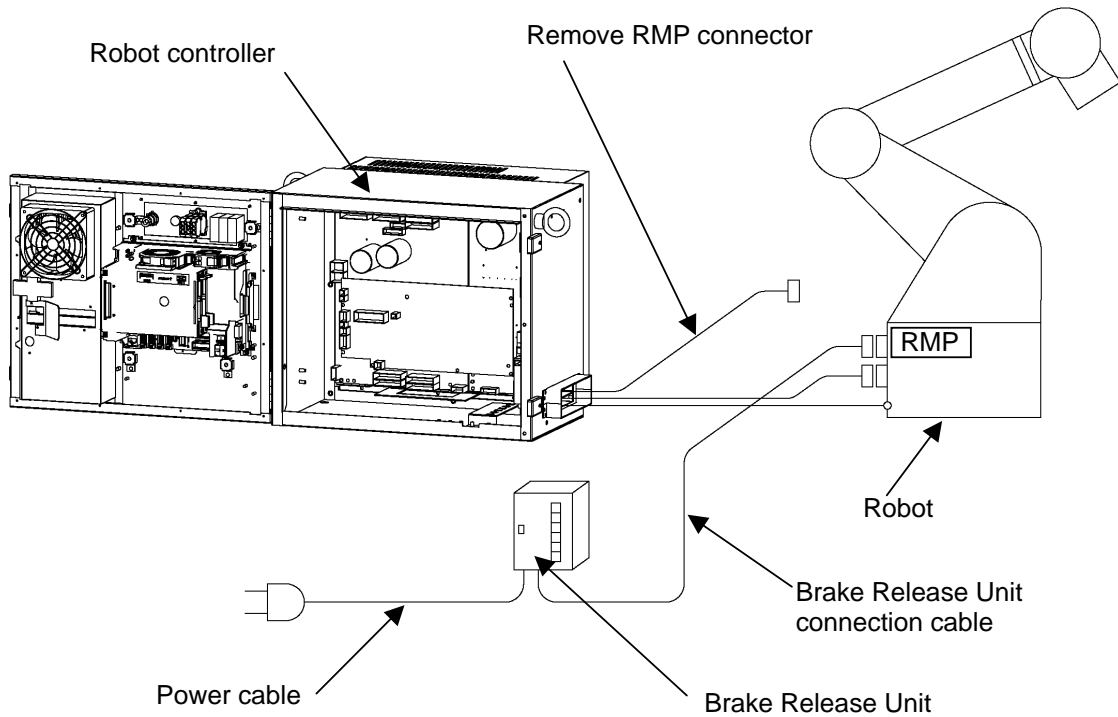


Fig.B.3 (b) How to connect brake release unit (In case of operating the Robot)

In case of operating to the auxiliary Axis

Operate the brake release unit according to the following procedures.

- (1) Support the auxiliary Axis by mechanical means to prevent it from falling down or rising up when the brake is released.
- (2) Connect the Brake Release Unit connection cable to Brake Release Unit.
- (3) Disconnect the aux. axis brake connector (CRR65A/B), and connect the CRR65A/B connector to the Brake Release Unit connection cable. Keep the connection of all cables of aux. axis motor (power, Pulsecoder, brake).
- (4) Connect the power cable of Brake release unit to power supply.
- (5) Press and hold the deadman switch in the middle position.
- (6) Press the brake switch '1', then brake will be released.

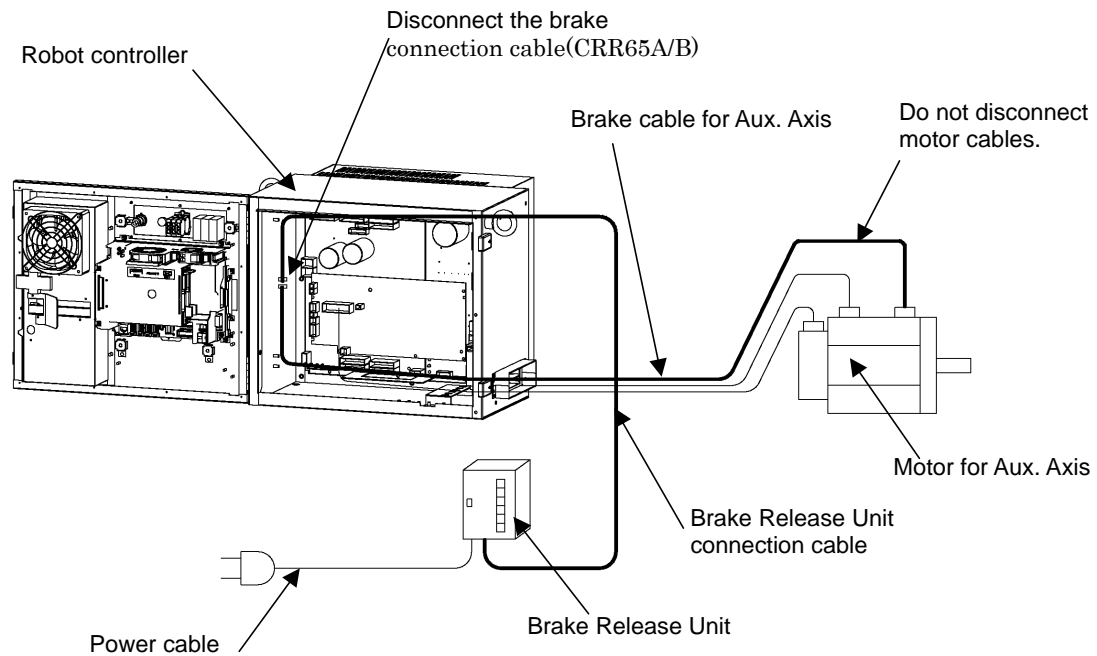


Fig.B.3 (c) How to connect brake release unit (In case of operating the Aux. Axis)

B.4 HOW TO CONNECT THE PLUG TO THE POWER CABLE (IN CASE OF NO POWER PLUG)

Connect the plug to the power cable as follows. This plug is provided by customer.

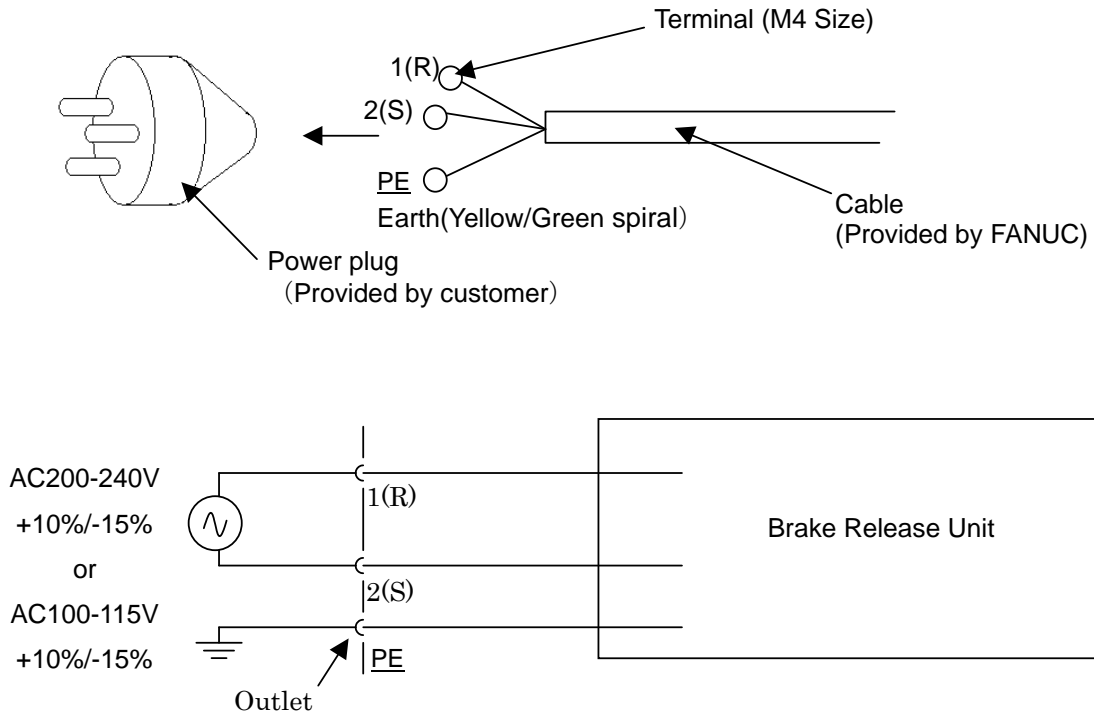


Fig.B.4 How to connect the plug to the power cable



WARNING

Only a specialist having the relevant expertise knowledge is permitted to connect the plug to the power cable.

In the EU area, only plug complying with the relevant European product standard can be used.

Do not install the plugs without protective earth pin.

B.5 DIMENSION

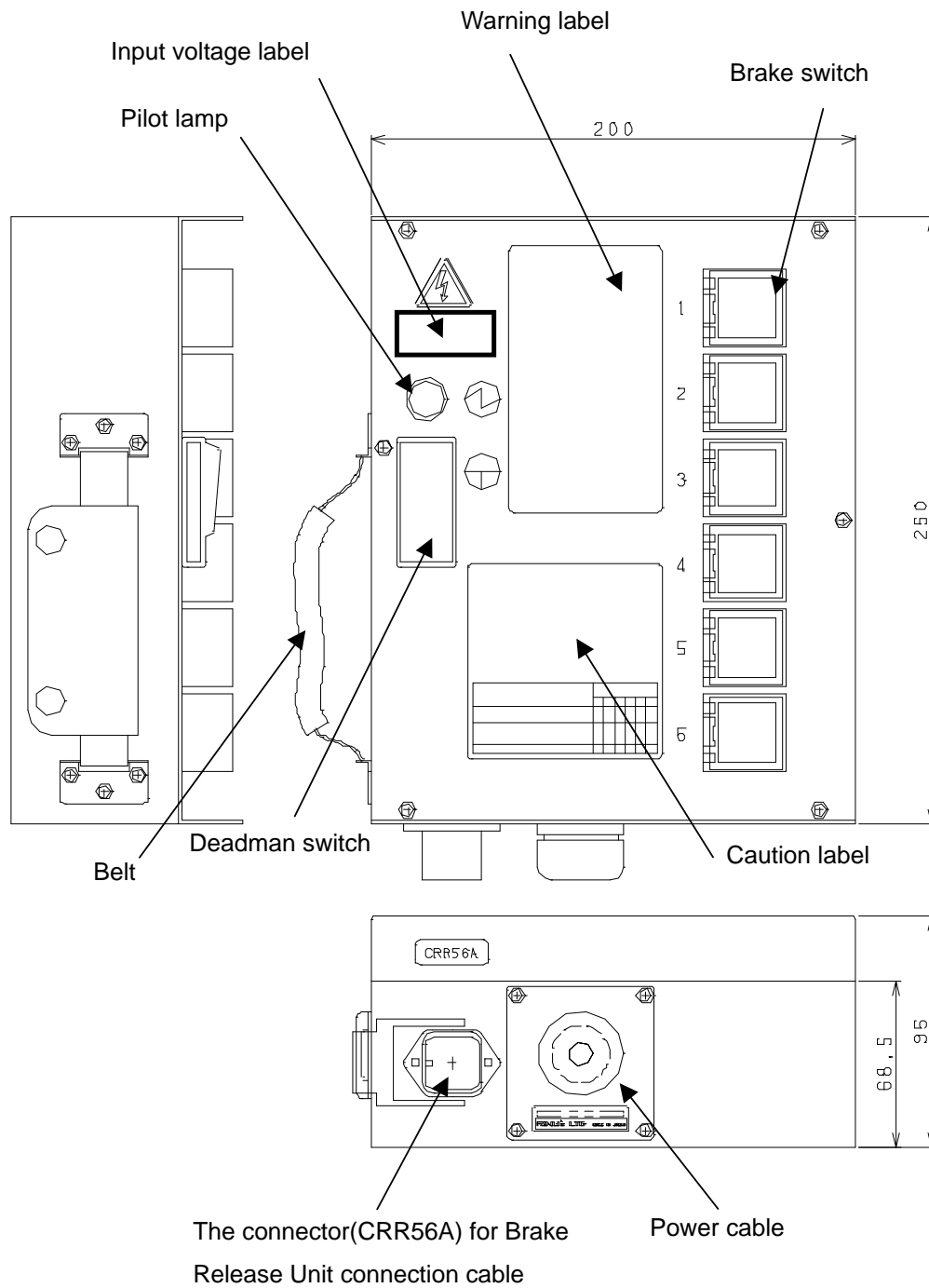


Fig.B.5 (a) Dimension of brake release unit (Front view)

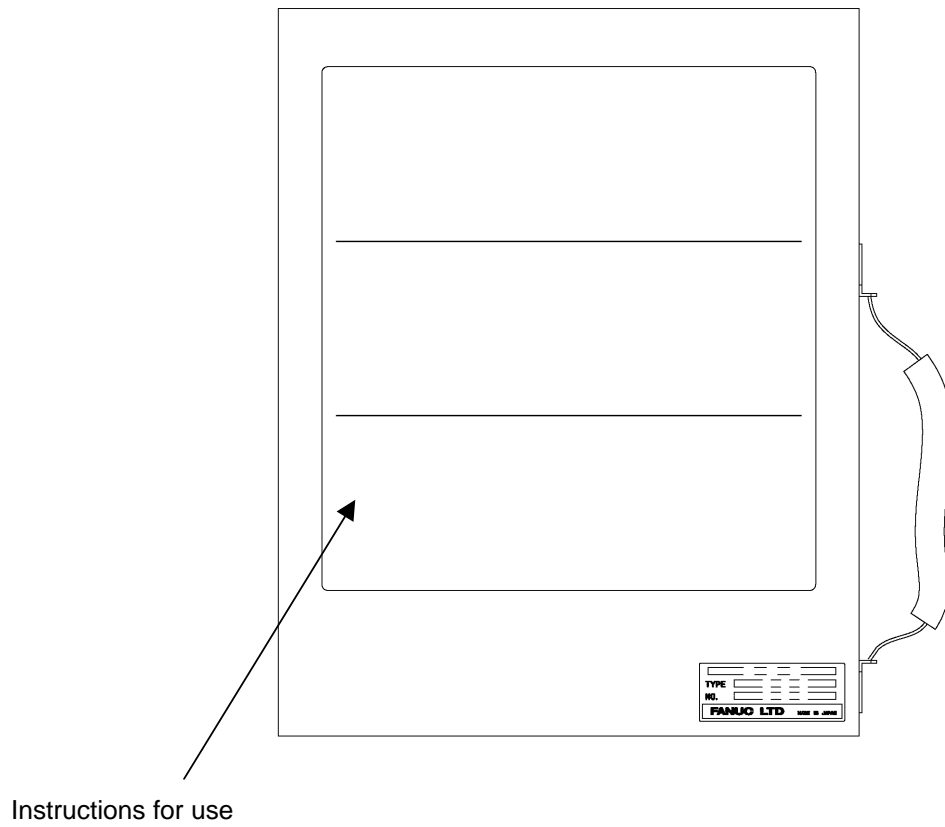


Fig.B.5 (b) Dimension of brake release unit (Rear view)

B.6 FUSE

The fuses are mounted inside this unit. Please check the fuse when the pilot lamp doesn't light even if deadman switch is pressed. When the fuse is blown, exchange the fuse after finding the root cause of failure, and taking the appropriate countermeasures.

Manufacturer: Daito Communication Co.
Specification: P420H
Rating: 2A

⚠ WARNING
When the fuse is replaced, the power cable of brake release unit must be disconnected.

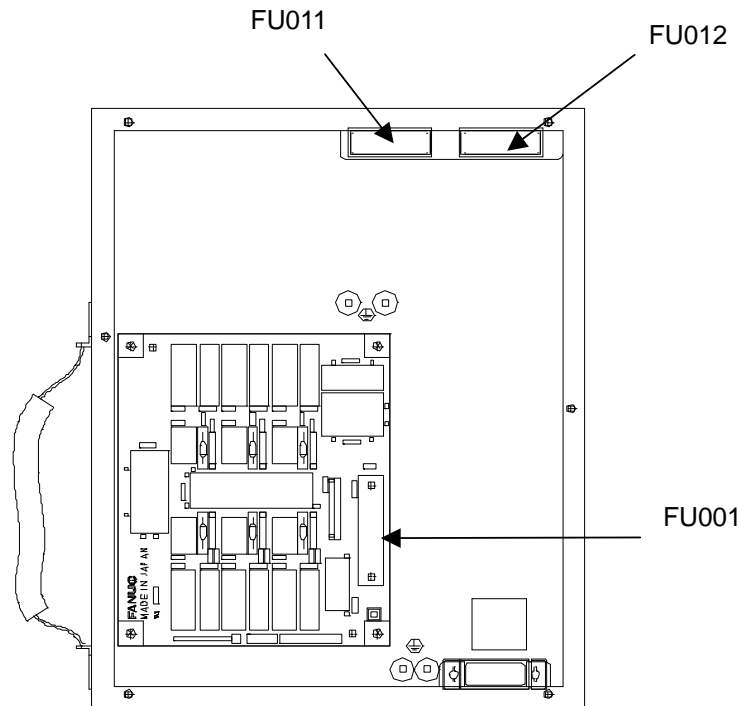


Fig.B.6 The location of fuses

B.7 SPECIFICATIONS

Input power supply

AC100-115V, 50/60Hz \pm 1Hz, single phase, +10%/-15%, 1A
AC200-240V, 50/60Hz \pm 1Hz, single phase, +10%/-15%, 1A

Weight

Brake Release Unit (AC 100V); 2.3 kg
Brake Release Unit (AC 200V); 3.5 kg

INDEX

<Number>

100BASE-TX connector (CD38R) pin assignments 179

<A>

ADJUSTMENT AND CHECKS AT INSTALLATION 193
ALARM OCCURRENCE SCREEN 15
ARC Weld Connection Cables (CRW11; Tyco
Electronics AMP K.K. 20 pin) 169

BACKPLANE BOARD (A20B-8101-0580) 83
Battery for Memory Backup (3 VDC) 114
BLOCK DIAGRAM 120
BLOCK DIAGRAM OF THE POWER SUPPLY 90
BRAKE RELEASE UNIT 217

<C>

CABLE CONNECTION FOR THE PERIPHERAL
DEVICES 170
CHECK AND REPLACEMENT SURGE ABSORBER
..... 76
Check items at installation 186
CHECKING THE POWER SUPPLY 91
COMPONENT FUNCTIONS 11
CONFIGURATION 4
CONFIRMATIONS BEFORE OPERATION 217
Connecting the Auxiliary Axis Brake (CRR65 A/B) ... 137
Connecting the Auxiliary Axis over Travel (CRM68). 138
CONNECTING THE COMMUNICATION UNIT 174
Connecting the External Emergency Stop 129
Connecting the Input Power Supply 128
Connection between RS-232-C interface and I/O device
..... 176
Connection between the ARC Mate 100iC/M-10iA,
ARC Mate 120iC/M-20iA, ARC Mate 0iA and End
Effector 160
Connection between the Connector Conversion Board
and Peripheral Devices 156
Connection between the LR Mate 200iC, ARC Mate
50iC and End Effector 159
Connection between the Main Board (CRMA15,
CRMA16) and Peripheral Devices 145
Connection between the Process I/O Board MA and
Peripheral Devices 152
Connection between the Process I/O Board MB and
Welding Machines 157
CONNECTION DIAGRAM BETWEEN
MECHANICAL UNITS 121
Connection of I/O Link 123
Connection of I/O the Link Cable 124
Connection to Ethernet 178
CONNECTOR CONVERTER BOARD
(A20B-2004-0410) 86

<D>

DIGITAL I/O SIGNAL SPECIFICATIONS 162
DIMENSION 222

<E>

ELECTRICAL CONNECTIONS 121
Electrical noise countermeasures 183
EMERGENCY STOP CONTROL BOARD
(A20B-2004-0290) 82
End Effector Control Interface 164
Ethernet Interface 178
EXTERNAL CABLE WIRING DIAGRAM 126
EXTERNAL VIEW OF THE CONTROLLER 4

<F>

FANUC I/O LINK 123
FUSE 224
FUSE-BASED TROUBLESHOOTING 65

<G>

GENERAL 119

<H>

HOW TO CONNECT THE PLUG TO THE POWER
CABLE (IN CASE OF NO POWER PLUG) 221
How to Disable/Enable HBK 194
How to Disable/Enable Pneumatic Pressure Alarm
(PPABN) 195

<I>

I/O SIGNALS OF MAIN BOARD 143
In Case of Main Board (CRMA15, CRMA16) 141
In the Case of the Connector Conversion Board 143
In the Case of the Process I/O Board MA 142
In the Case of the Process I/O Board MB 142
INSTALLATION 188
INSTALLATION CONDITION 192
Installation Method 188
Interface 174
INTERFACE FOR END EFFECTOR 159
INTERFACE FOR PERIPHERAL DEVICES 145

<L>

Leading out the Ethernet cable 179
LED OF SERVO AMPLIFIER 88

<M>

MAIN BOARD (A20B-8200-0470) 79
MANUAL OPERATION IMPOSSIBLE 77
MASTERING 19
MOUNTING METHOD OF TEACH PENDANT
HOOK 191

<O>

OPERATION 218

OVERVIEW	3	<S>	
<P>		SAFETY PRECAUTIONS	s-1,217
PERIPHERAL DEVICE AND END EFFECTOR		SAFETY SIGNALS	18
INTERFACES	139	SERVO AMPLIFIERS	87
Peripheral Device Cable Connector	171	SETTING OF SERVO AMPLIFIER	89
Peripheral Device Connection Cable	170	SETTING THE POWER SUPPLY	90
Peripheral Device Interface	162	Specification for Arc Welding Machine Interface	
Peripheral Device Interface A1 Cable (CRMA15: Tyco		Input/Output Signals	165
Electronics AMP, D-1000 series, 40 pins)	168	SPECIFICATIONS	224
Peripheral Device Interface A2 Cable (CRMA16: Tyco		SPECIFICATIONS OF THE CABLES USED FOR	
Electronics AMP, D-1000 series, 40 pins)	168	PERIPHERAL DEVICES AND WELDERS	168
Peripheral Device Interface B1 and B2 Cables		<T>	
(CRMA52; Tyco Electronics AMP K.K. 30 pin)	169	Teach Pendant Cable	127
PERIPHERAL DEVICE INTERFACE BLOCK		TOTAL CONNECTION DIAGRAM	199
DIAGRAM	141	TRANSPORTATION	187
Peripheral Device Interface Processing	194	TRANSPORTATION AND INSTALLATION	187
POSITION DEVIATION FOUND IN RETURN TO		TROUBLESHOOTING	13
THE REFERENCE POSITION (POSITIONING)	77	TROUBLESHOOTING BASED ON LED	
POWER CANNOT BE TURNED ON	13	INDICATIONS	69
PREFACE	p-1	TROUBLESHOOTING USING THE ERROR CODE	21
PREVENTIVE MAINTENANCE	11	Twisted-pair cable specification	180
PRINTED CIRCUIT BOARDS	79	<W>	
PROCESS I/O BOARD MA (A20B-2004-0380)	84	When the Teach Pendant Cannot be Powered on	13
PROCESS I/O BOARD MB (A20B-2101-0730)	85	When the Teach Pendant Does Not Change from the	
<R>		Initial Screen	14
Recommended Cables	173		
REPLACING A UNIT	92		
REPLACING BATTERY	114		
REPLACING CARDS AND MODULES ON THE			
MAIN BOARD	94		
Replacing External Air Fan Unit and Door Fan	108		
REPLACING FUSES	110		
Replacing Fuses in the Main board	111		
Replacing Fuses in the Servo Amplifier	110		
REPLACING RELAYS	113		
Replacing Relays on the E-stop Board	113		
REPLACING SERVO AMPLIFIERS	104		
REPLACING THE AC FAN MOTOR	108		
Replacing the Backplane Board (Unit)	92		
REPLACING THE CONTROL SECTION FAN			
MOTOR	107		
REPLACING THE E-STOP UNIT	103		
Replacing the Fuse on the E-stop Boards	112		
Replacing the Main board	93		
REPLACING THE PRINTED-CIRCUIT BOARDS	92		
REPLACING THE REGENERATIVE RESISTOR			
UNIT	100		
REPLACING THE TEACH PENDANT and <i>i</i>			
PENDANT	106		
Resetting Overtravel	194		
RESETTING OVERTRAVEL AND EMERGENCY			
STOP AT INSTALLATION	193		
Robot Connection Cables	126		
RS-232-C Interface	174		
RS-232-C interface signals	175		

REVISION RECORD

Edition	Date	Contents
07	July.2012	<ul style="list-style-type: none">• Addition of ARC Mate 0iA• Error correction
06	May.2011	<ul style="list-style-type: none">• Addition of ARC Mate 100iCe, M-10iAe, ROBOWELD• Error correction
05	May.2009	<ul style="list-style-type: none">• Addition of ARC Mate 120iC, M-20iA, M-1iA
04	Nov.2008	<ul style="list-style-type: none">• Addition of ARC Mate 50iC
03	Jul.,2008	<ul style="list-style-type: none">• Addition of ARC Mate 100iC
02	Dec.,2007	<ul style="list-style-type: none">• Addition of I/O Link and Process I/O
01	Jun.,2007	

B-82725EN-1/07

