

Control Gate Valve with Direct Drive

This manual is valid for the valve ordering numbers:
 642...-E52

The respective product identification is given on each valve in the following way
 (or similar):

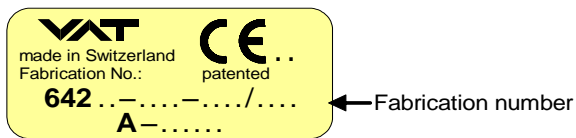

Explanation of symbols:



Read declaration carefully before you start any other action!



Keep body parts and objects away from the valve opening!



Attention!



Hot surfaces; do not touch!



Product is in conformity with EC guidelines, if applicable!



Loaded springs and/or air cushions are potential hazards!



Disconnect electrical power and compressed air lines. Do not touch parts under voltage!



Wear gloves!



Read these «**Installation, Operating & Maintenance Instructions**» and the enclosed «**General Safety Instructions**» carefully before you start any other action!



Installation, Operating, and Maintenance Instructions

Series 64.2, DN 160 - 400

Imprint:

Manufacturer VAT Vakuumventile AG, CH-9469 Haag, Switzerland

Website
www.vatvalve.com

Phone
+41 81 771 61 61

Fax
+41 81 771 48 30

Email
CH@vatvalve.com

Publisher VAT Vakuumventile AG, CH-9469 Haag, Switzerland

Editor VAT Vakuumventile AG, CH-9469 Haag, Switzerland

Print VAT Vakuumventile AG, CH-9469 Haag, Switzerland

Copyright © VAT Vakuumventile AG 2013

No part of these Instructions may be reproduced in any way (photocopies, microfilms or any other reproduction processes) nor may it be manipulated with electronic systems, duplicated or distributed without written permission from VAT. Offenders are liable to pay damages.

The original VAT firmware and updated state of the art versions of the VAT firmware are intended for use with VAT products. The VAT firmware contains a limited, time unlimited user license. The VAT firmware may not be used for purposes other than those intended nor is it permitted to make copies of the VAT firmware. In particular, it is strictly forbidden to give copies of the VAT firmware to other people.

The use of trade names, brand names, trademarks, etc. in these Instructions does not entitle third parties to consider these names to be unprotected and to use them freely. This is in accordance with the meaning of the laws and acts covering brand names and trademarks.

Intended Use of Product

Use product for vacuum applications under the conditions indicated in chapter "Technical Data" only! Other applications are only allowed with the written permission of VAT.

Corrosive process gases may impact the performance of the product. Please contact VAT to assure that the product is compatible with the process gases used in your application.

Technical data

Pressure range		DN 160 - 200: 1×10^{-8} mbar to 2 bar (abs)
		DN 250 - 400: to 1.2 bar (abs)
Differential pressure on the closed gate		DN 160 - 200: 2 bar in either direction
		DN 250 - 400: 1.2 bar in either direction
Max. differential pressure at opening		30 mbar
Admissible temperature: Valve		< 150°C
Actuator		< 50°C
Operation		only with VAT PM-4/5 controller and connection cable

Further data according to VAT catalogue «Vacuum Valves 2016».

Installation into the vacuum system

The valve seat side is indicated by the symbol "▽" on the connection flange.

Tightening torque for mounting screws on flanges

1. Mounting with centering ring

Tighten mounting screws of the flanges uniformly in crosswise order. Observe the maximum torque levels in the following table. Higher tightening torques deform the valve body and can lead to an improper function of the valve.

DN		max. tightening torque (Nm)			max. tightening torque (lbs . ft)		
mm	inch	ISO-F	JIS	ASA-LP	ISO-F	JIS	ASA-LP
63/100	4	8 – 10	8 – 10	8 – 10	6 – 8	6 – 8	6 – 8
160	6	13 – 15	13 – 15	20 – 30	9 – 11	9 – 11	15 – 22
200	8	13 – 15	13 – 15	20 – 30	9 – 11	9 – 11	15 – 22
250	10	17 – 20	17 – 20	40 – 60	13 – 15	13 – 15	30 – 44
320	12	17 – 20	17 – 20	40 – 60	13 – 15	13 – 15	30 – 44
350	14	17 – 20	17 – 20	40 – 60	13 – 15	13 – 15	30 – 44
400	16	17 – 20	30 – 35	55 – 80	13 – 15	22 – 26	41 – 59

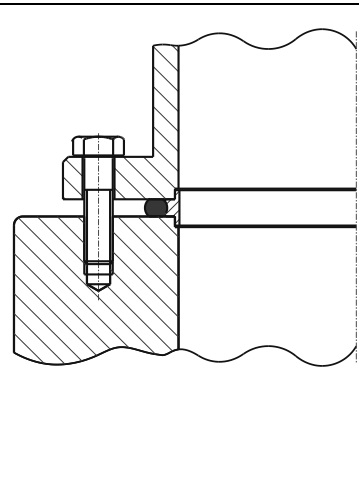

2. Mounting with O-ring in groove

Tighten mounting screws of the flanges uniformly in crosswise order. Observe the maximum torque according to the grade of screws and depth of thread you use.

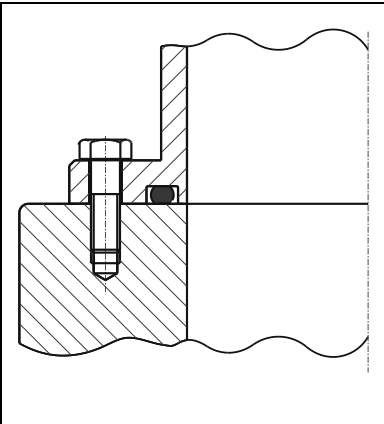

Admissible forces

Forces from evacuating the system, from the weight of other components, and from heating can lead to deformation of the valve body and to malfunction of the valve. The stress has to be relieved by suitable means, e.g. bellows sections. The following forces are admissible:

DN (nom. I.D.)		Axial tensile or compressive force «F _A »		Bending moment «M»	
mm	inch	N	lbf	Nm	lbf · ft
63	2 ¹ / ₂	1960	440	78	58
100	4	2450	560	98	72
160	6	2940	660	147	108
200	8	2940	660	147	108
250	10	3430	770	196	145
320 / 350	12 / 14	3920	880	294	217
400	16	7840	1760	980	722

If a combination of both forces (F_A and M) occurs, the values mentioned above are invalid. Please contact VAT for more information.

Electrical connection



Do not touch electrical parts under voltage!



This control valve may only be operated with a VAT PM-4 or PM-5 Adaptive Pressure Controller and the corresponding cable supplied by VAT.

The PM-4 or PM-5 control unit has to be turned off for at least 60 seconds before connecting or disconnecting the cable to the valve.

Operation

Operation is allowed only after the installing procedure.

Differential pressure

Do not open the valve, if the differential pressure on the gate is equal or larger than 30 mbar.

Power failure

	with power-fail option	without power-fail option
Valve closed	no change	no change
Valve open or control position	will close	undefined



Preventive maintenance

The numbers in brackets refer to the drawing on page 9

Note! The process environment of your application (i.e. corrosive gases, deposition on parts inside valve body) may require more frequent preventive maintenance intervals than suggested below.

Heating of the valve is highly recommended for contaminating processes. VAT offers customized heater boxes for series 64.2 valves.

For quick maintenance, VAT recommends to exchange the complete gate assembly in order to reduce downtime of the system.

Warning! Never remove striking plate (20) from the mechanism (16)!

Recommended maintenance after every 100'000 cycles (25'000 for DN 400 vertical mounting only):

- Clean gate O-ring, clean inside surfaces
- Inspect the bonnet seal, ball bearings and crank bolt.
- Replace items (Spare part kit 'C'), if corrosion or deposition of process by-products occurred.
- In corrosive processes: Relubricate locking balls with VAT Vacuum grease. Replace and lubricate locking balls, if corrosion has occurred.

Recommended maintenance after every 200'000 (50'000 for DN 400 vertical mounting only) cycles:

In addition to the 100'000 cycles maintenance interval, VAT recommends to clean and lubricate the ball bearings (replace, if necessary), replace the locking balls, replace the crank bolt, inspect, clean and re-lubricate the ball guide plate (replace, if friction increased), inspect, clean and re-lubricate the feedthrough O-ring (replace it if necessary)

The following table refers to the items on page 4 and the spare parts list on page 6.

Cycles *)	Procedures	Recommended spare parts kits
Every 100'000	1., 2., 3.	A, E For individual items see spare parts list on page 6
Every 200'000	1., 2., 3., 4., 5., 6., 7.	B, C, E For individual items see spare parts list on page 6

*) Definition of cycle: Movement of the gate from open to closed or control position and back to open position

Procedures

1. Precondition for all maintenance work

- Vent both valve chambers
- Give 'OPEN' command on PM-4 or PM 5 control to open gate valve
- Turn off power to PM-4 or PM-5 control unit. If power-fail option is installed, press 'F2' key to disable power-fail option temporarily and turn off power to PM-4 or PM-5 control unit within following 60 seconds
- Wait for another 60 seconds, then disconnect cable to valve actuator

2. Removal of the gate assembly (4) / Replacement of the crank bolt (6) / Replacement of the bonnet seal (3)

- Unfasten the bonnet screws (1)
- Remove the bonnet plate (2) and the bonnet seal (3)
- Pull the lever (15) a little bit out of the bonnet opening
- Loosen the hexagonal socket-head bolt (7) for the crank bolt (6)
- Remove the crank bolt (6), while lifting the gate assembly (4) a little bit if necessary



- Slide out the gate assembly (4) carefully from the body and put it on a clean workshop place
- Re-assemble in reverse direction
- Fasten the screws (1) crosswise with equal torque: ≈ 14 Nm (10 lbf ft) with DN 63 - 100
 ≈ 18 Nm (13 lbf ft) with DN 160 – 400

3. Replacement of the gate O-ring (5)

- Remove O-ring carefully and avoid any damage to the groove sealing surface
- Clean groove and sealing surface
- Install new O-ring by pressing it crosswise uniformly into the groove. Make sure, the O-ring is not twisted (pay attention to the seam of the O-ring)

4. Replacement of the ball bearings (22)

- DN160 - 200: Replace complete ball bearing assembly (2 pcs)
- DN250 - 400: Replace each individual ball bearing (4 pcs)

5. Replacement of the locking balls (19)

- Put the gate assembly (4) carefully on a clean workshop place with the O-ring side to the bottom
- Remove the 6 hexagonal nuts (17)
- Lift off counter plate (18) and ball guide plate (16)
- Replace locking balls (19), **lubricate balls** with VAT vacuum grease (E) before installation
- Reassemble in reverse order, lubricate weld bolts on plate with VAT vacuum grease (E) before mounting hexagonal nuts

6. Removal of actuator (10) for change of rotary seal (included in seal kit 'A')

- Remove gate assembly as per items 1 and 2
- Move the actuator to position 800 (PM control: Position mode, select 800)
- Press 'F2', if power-fail option is installed to disable the power fail option
- Turn off power to PM control unit.
- Remove roll pin (8) out of the shaft feedthrough. Use VAT assembling tool or a punch
- Remove lever (15). Note the marking "A" to be on top side when reinstalling
- Remove 4 hexagonal socket-head bolts (9) on top of the direct drive actuator (10)
- Remove complete direct drive actuator assembly (10)
- Install in reverse order



Spare parts

The item numbers refer to the assembly drawing on page 9

Item	Description	Part No.				
		160	200	250	320 350	400
3	Bonnet seal	77781-R1	77784-R1	N-5100-378	N-5100-382	N-5100-383
4	Gate assembly	84275-R1	84608-R1	83481-R1	209812	517637
5	Gate O-ring	N-5102-364	N-5100-372	N-5102-453	N-5102-457	N-5100-461
6	Crank bolt	79090-R1	79090-R1	85783-R1	85783-R1	87749-R1
7	Crank bolt mounting screw with spring washer	N-6005-458 N-6162-405	N-6005-458 N-6162-405	N-6005-502 N-6162-407	N-6005-502 N-6162-407	N-6005-502 N-6162-407
8	Feedthrough connection pin	N-6097-480	N-6097-480	N-6097-509	N-6097-509	N-6097-509
10	Actuator A-side B-side Actuator with interm. Pump. A-side B-side	247102 247103 247104 247105	247102 247103 247104 247105	232850 232851 232852 232853	232850 232851 232852 232853	232850 232851 232852 232853
11	Actuator seal	N-5100-225	N-5100-225	N-5100-228	N-5100-228	N-5100-228
19	Locking balls	N-6121-051 (18 pcs)	N-6121-051 (24 pcs)	N-6121-081 (18 pcs)	N-6121-081 (24 pcs)	N-6121-097 (32 pcs)
22	Ball bearing assembly	84326-R1 (2 pcs)	80642-R1 (2 pcs)	99205-R1 (4 pcs)	99205-R1 (4 pcs)	77286-01 (4 pcs)
A	Seal kit	246755	246756	246757	246760	245476
B	Actuator replacement kit, consisting of: actuator seal, bonnet seal, feedthrough connection pin	260150	260151	260152	260153	260154
C	Gate spare parts kit, consisting of gate O-ring, crank bolt, crank bolt connection screw, ball bearings, locking balls	88725-R1	88726-R1	88727-R1	88728-R1	88729-R1
D	Feedthrough assembling tool	240451		97381-R1		
E	VAT vacuum grease (40 g)	N-6951-012				

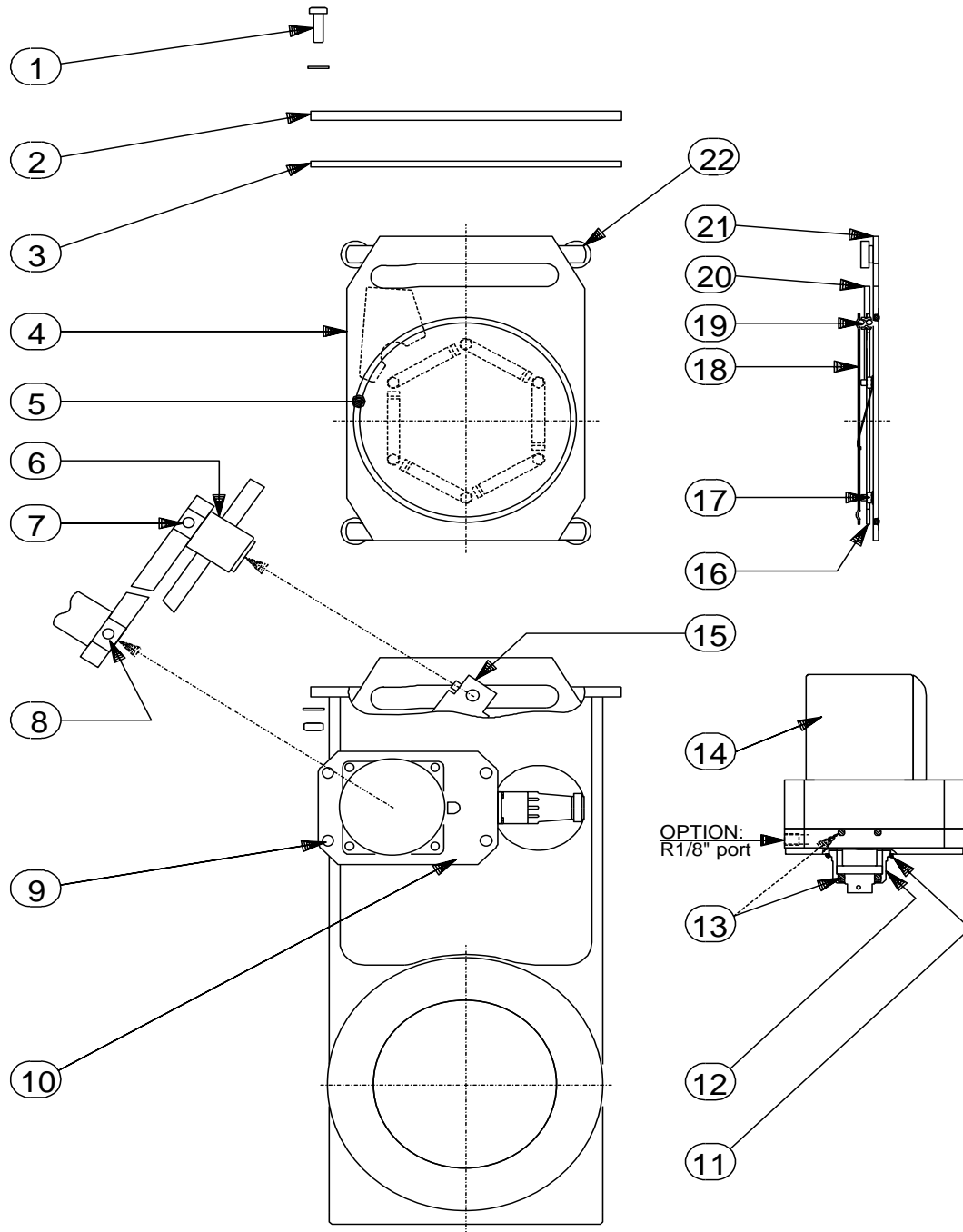

Trouble shooting

Valve does not close/open/control	<ul style="list-style-type: none">- Is differential pressure < 30 mbar?- Do not operate valve, while differential pressure is > 30 mbar. Equalize pressure first.- Is PM control unit activated (hooked up to power, switched on)?- Is valve cable connected properly?
Pressure control does not work properly	<ul style="list-style-type: none">- Please refer to Trouble Shooting section of PM control unit (operation instruction M64005EB)
Leak at gate	<ul style="list-style-type: none">- Clean valve seat and gate!- Check surface of seat and O-ring- Change O-ring, if necessary
Leak at body	<ul style="list-style-type: none">- Flange seals leaktight?- Bonnet seal leaktight?- Screws at bonnet tightened properly?

Repairs

Contact VAT for repairs or maintenance. The fabrication No. marked on the valve body has always to be specified. It has to be individually decided whether the work can be performed by the customer or has to be carried out by VAT.

Power to the control unit has to be switched off and the cable to the valve has to be disconnected (wait at least 60 seconds) before removal/installation of the valve from/into the system.



Keep fingers and objects away from the valve opening!

Products returned to VAT for repair have to be free of harmful substances such as e.g. toxic, caustic or microbiological ones. For radioactively contaminated products the customer has to fill in the VAT form «Contamination and Radiation Report» and to send it with the product. The form is available at VAT. The maximum permissible values indicated in the form must not be exceeded.

Warranty

Each product sold by VAT Vakuumentile AG (VAT) is warranted to be free from the manufacturing defects that adversely affect the normal functioning thereof during the one-year period immediately following delivery thereof by VAT, provided that the same is properly operated under conditions of normal use and that regular, periodic maintenance and service is performed or replacements made, in accordance with the instructions provided by VAT. The foregoing warranty shall not apply to any product or component that has been repaired or altered by anyone other than an authorized VAT representative or that has been subject to improper installation or abuse, misuse, negligence or accident. VAT shall not be liable for any damage, loss, or expense, whether consequential, special, incidental, direct or otherwise, caused by, arising out of or connected with the manufacture, delivery (including any delay in or failure to deliver), packaging, storage or use of any product sold or delivered by VAT shall fail to conform to the foregoing warranty or to the description thereof contained herein, the purchaser thereof, as its exclusive remedy, shall upon prompt notice to VAT of any such defect or failure and upon the return of the product, part or component in question to VAT at its factory, with transportation charges prepaid, and upon VAT's inspection confirming the existence of any defect inconsistent with said warranty or any such failure, be entitled to have such defect or failure cured at VAT's factory and at no charge therefor, by replacement or repair of said product, as VAT may elect. VAT MAKES NO WARRANTY OR REPRESENTATION OF ANY KIND, EXPRESS OR IMPLIED, (INCLUDING NO WARRANTY OR MERCHANTABILITY), EXCEPT FOR THE FOREGOING WARRANTY AND THE WARRANTY THAT EACH PRODUCT SHALL CONFORM TO THE DESCRIPTION THEREOF CONTAINED HEREIN, and no warranty shall be implied by law.

Furthermore, the «Terms of sale» at the back of the price list are applicable.