



XR[®]-AT Powered Mixer

Operating Manual





This device complies with Part 15 of the FCC rules and Industry Canada license-exempt RSS Standard(s). Operation is subject to the following two conditions: (1) this device may not cause harmful interference, and (2) this device must accept any interference received, that may cause undesired operation.

Le présent appareil est conforme aux CNR d'Industrie Canada applicables aux appareils radio exempts de licence. L'exploitation est autorisée aux deux conditions suivantes: (1) l'appareil ne doit pas produire de brouillage, et (2) l'utilisateur de l'appareil doit accepter tout brouillage radioélectrique subi, même si le brouillage est susceptible d'en compromettre le fonctionnement.

Warning: Changes or modifications to the equipment not approved by Peavey Electronics Corp. can void the user's authority to use the equipment.

Note – This equipment has been tested and found to comply with the limits for a Class B digital device, pursuant to Part 15 of the FCC Rules. These limits are designed to provide reasonable protection against harmful interference in a residential installation. This equipment generates, uses, and can radiate radio frequency energy and, if not installed and used in accordance with the instructions, may cause harmful interference to radio communications. However, there is no guarantee that interference will not occur in a particular installation. If this equipment does cause harmful interference to radio or television reception, which can be determined by turning the equipment off and on, the user is encouraged to try and correct the interference by one or more of the following measures.

- Reorient or relocate the receiving antenna.
- Increase the separation between the equipment and receiver.
- Connect the equipment into an outlet on a circuit different from that to which the receiver is connected.
- Consult the dealer or an experienced radio/TV technician for help.

Caution

The equipment complies with FCC radiation exposure limits set forth for an uncontrolled environment.



XR[®]-AT

Powered Mixer

Congratulations on the purchase of your new XR[®]-AT powered mixer from Peavey[®]. The Peavey XR-AT is a revolutionary all-in-one powered mixer that provides everything a musician or DJ needs, including up to eight combination XLR and 1/4" inputs using Peavey's award winning mic preamps and dual 500 Watt amplifiers for crystal clear audio reproduction. Plus, for the first time ever, the XR-AT mixer includes Antares[®] Auto-Tune[®] pitch correction technology. This technology can literally help anyone sing in key and is used on professional recordings and live performances throughout the world.

The Peavey XR-AT uses exclusive features like Midmorph[®] to accurately improve tone and clarity of vocals. Feedback is quickly and easily identified and removed with Peavey's dual 9-band graphic EQ's combined with our patented and revolutionary FLS[®] Feedback Locating System. The XR-AT is equipped with Peavey's exclusive Kosmos[®]-C technology, which drastically enhances the low end of the audio spectrum. Built-in 24-bit digital effects complement the already feature-packed unit.



Before you begin using your powered mixer it is very important to ensure that the product has the proper AC voltage supplied. You can find the proper voltage for your amp printed next to the IEC line (power) cord on the rear panel of the unit.

Features:

- FLS[®] Feedback Locating System
- Midmorph[®] EQ
- Kosmos[®]-C
- On-board 24-bit digital effects with mute button
- Digital effects parameter control
- Combination XLR and 1/4" input jacks
- Dual 9-band graphic EQ with FLS[®]
- Master mic mute
- Footswitchable Effects Defeat
- Global 48 volt phantom power
- RCA, 3.5mm media Inputs
- Bluetooth[®] streaming
- USB Audio playback
- Selectable main or monitor dual power amp
- RCA record outputs
- LED meter bridge
- Power amp sub-sonic filter
- Clip and signal present indicators
- Main and monitor 1/4" line level outputs
- DDT[™] speaker protection circuit
- Three channels of Antares[®] Auto-Tune[®] pitch correction



VENTILATION: For proper ventilation, allow 6" (15,5 cm) clearance on all sides.

Channel Controls

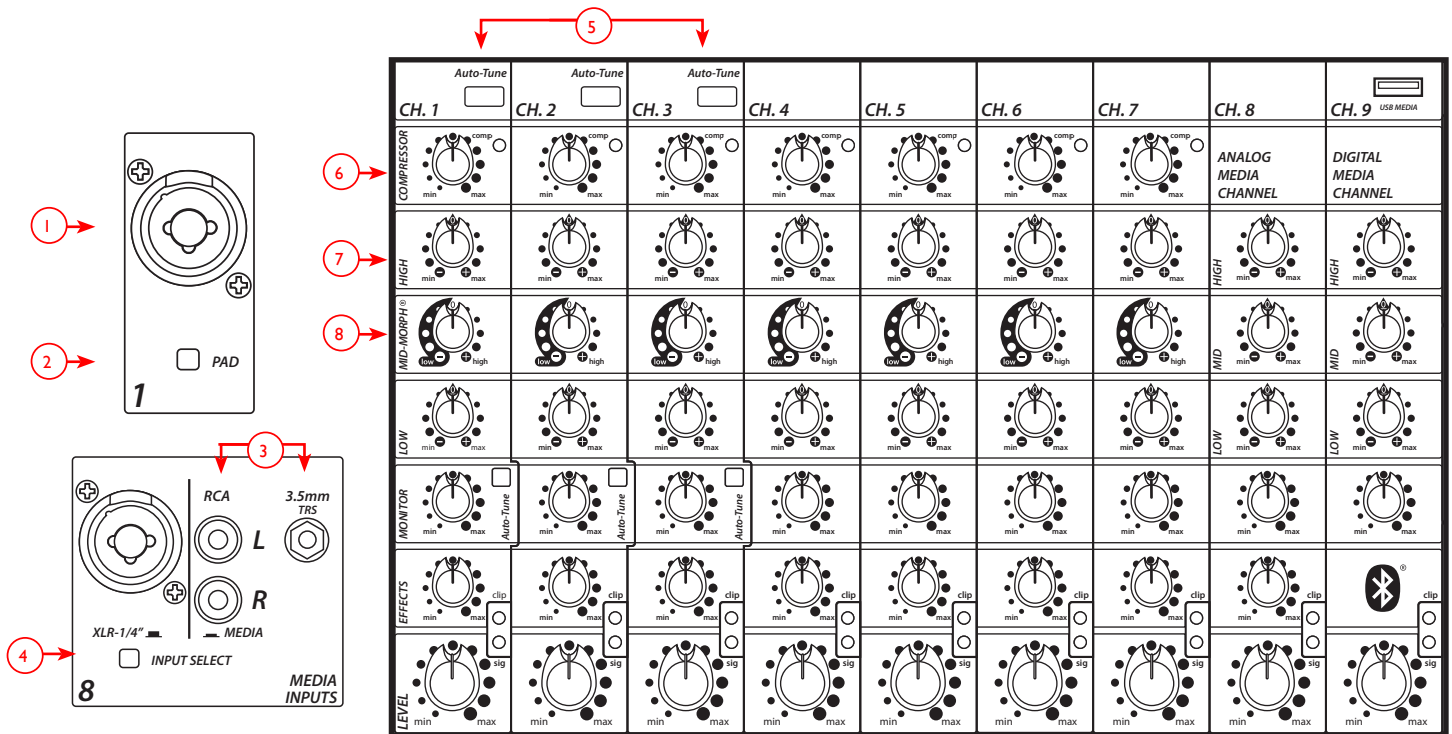

1 MIC/LINE INPUT (CH.1-8)

This combination input jack can accept either a 1/4" (balanced or unbalanced) input or an XLR balanced, low-impedance connection. The tip is positive on the 1/4" balanced input, and pin 2 is positive on the XLR

2 PAD (CH. 1-7)

When engaged, the pad reduces the input signal by 25dB. If you notice distortion from a particular channel or if the channel becomes loud very quickly, try engaging this switch. In addition to increasing the dynamic range, the channel can now accommodate a higher input level before clipping occurs, which may be helpful when close-mic'ing a loud guitar amp or drum kit, for example.

3 MEDIA INPUTS (CH.8 RCA and 3.5mm)

These inputs, both RCA and 3.5mm jacks accept a stereo input from the output of an MP3 Player, CD player, tape deck or other similar device.

4 INPUT SELECT SWITCH (CH. 8)

This switch allows the user to select the input signal being sent to channel 8. In the "up" position, the Mic-Line preamp is active. In the "down" position, the RCA-3.5mm media inputs are active.

5 AUTO-TUNE ON/OFF (CH 1-3)

Each of the first three channels of the XR-AT can be routed through the world famous Auto-Tune® processing for automatic pitch correction. These three backlit switches indicate the status of the Auto-Tune in each channel. They also allow the Auto-Tune process to be bypassed with the push of a button. When the switch is lit, Auto-Tune is active. When it is dark, the Auto-Tune process is bypassed.

6 COMPRESSOR AND COMP LED (CH 1-7)

This knob adjusts the amount of compression applied to the channel. As the knob is turned to the right, the mixer automatically raises the compression ratio while adjusting the output gain accordingly. The result is a

narrower, more even dynamic range, as louder signals are softened while the overall level is boosted. Avoid setting the knob too high, however, as excess compression may lead to feedback. The LED will light red when the signal level is high enough to activate the compression.

7 HIGH EQ

This High EQ shelving type of active tone control varies the treble frequencies (+/- 15 dB at 12kHz) and is designed to remove noise or add brilliance to the signal, depending on the quality of the source.

8 MID-MORPH EQ (CH. 1-7)

Where most mid-range controls work at just one frequency, the Mid-Morph® works at two. When turned counterclockwise, it cuts at 250Hz to reduce frequencies that muddy the sound. When turned clockwise, it boosts at 4kHz to add intelligibility to vocals. Either way, improved vocal or instrument definition can be achieved.

Channel Controls

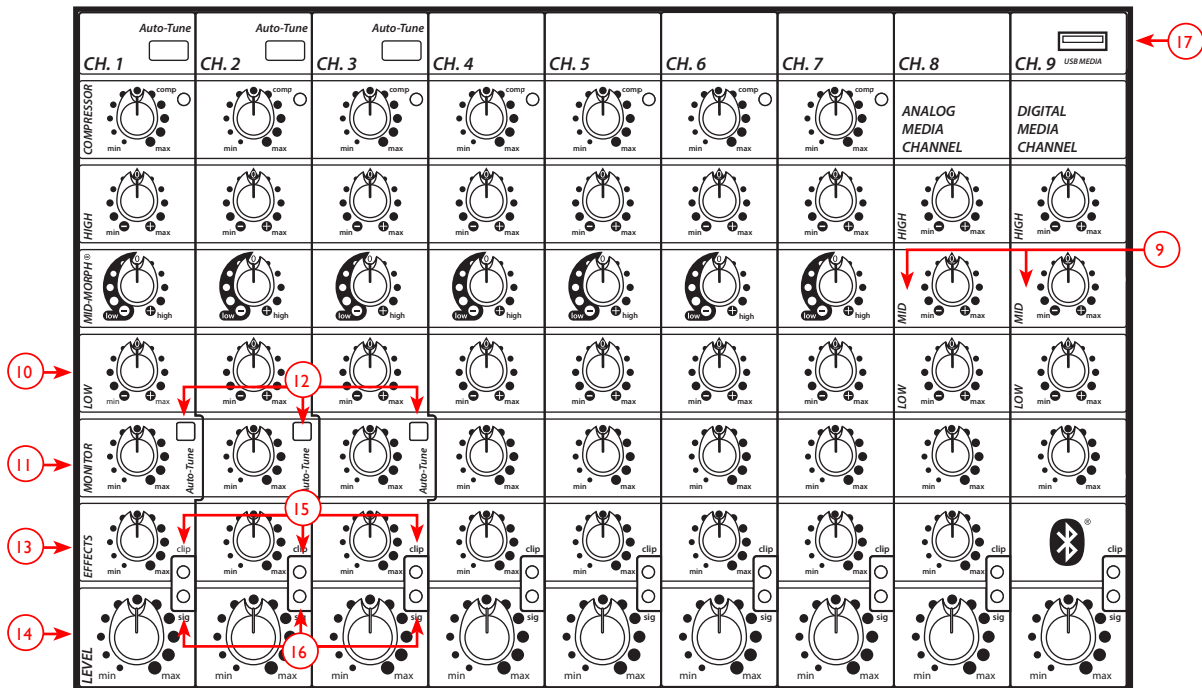

9 MID EQ (CH. 8 & 9)

The mid EQ is a band-pass (peak/notch) type of active tone control that varies the mid-range frequencies (+/-15dB at 450Hz).

10 LOW EQ

A shelving type of EQ that varies the bass frequency levels (+/- 15dB at 80Hz). Low EQ adds depth to thin-sounding signals or cleans up the muddy ones. As with any EQ, use sparingly. Too much of this EQ can give you a booming bottom end.

11 MONITOR SEND

The monitor send adjusts the level of the channel signal added to the monitor mix.

12 AUTO-TUNE TO MONITOR BUTTON (CH. 1-3)

This allows the user to select whether to send the dry signal or the Auto-Tuned signal to the monitors in the Auto-Tune® capable channels.

13 EFFECTS SEND (CH. 1-8)

This control adjusts the level of the channel signal added to the effects mix. The signal is sent to the internal effects processor. Turning the knob to the left (o) will turn off the effects on the associated channel, while turning the knob to the right will increase the amount of the selected effect.

14 LEVEL

This control sets the signal level sent to the main mix.

15 CLIP

When this LED turns on or blinks red, it is an indication that the signal in the channel is potentially too strong and could cause distortion. Turn down the Level control (14) until the Clip light is no longer present. If you are having difficulty getting a clean signal, try varying the output of the connected device, if possible.

16 SIG

When this LED is green, it is an indication the mixer is receiving signal at the input of the channel. If you are having trouble getting sound out of the mixer and this LED is not on, check the microphone, instrument or cable that is connected to the channel.

17 USB MEDIA JACK (CH. 9)

A-type USB connector to which a removable data storage device can be connected to play back music.

Master Controls

USB PLAYBACK:

First, make sure channel 9 is in USB playback mode by checking the status of the Ch 9 INPUT button (37). When the switch is dark, channel 9 is in USB playback mode. If it is blinking or solid blue, it is in Bluetooth mode. The bottom of the LCD display will say “Insert USB Drive” when in USB playback mode. Insert your USB drive in the USB Media Jack (17) at the top of channel 9. The mixer will now go into folder navigation mode.

In folder navigation mode, you can navigate through all of the folders present in the USB drive. The first folder in the list will always be “ROOT”. This is the root directory of the USB drive and will contain any songs that are not in a specific folder. To navigate, use the “Media Select” encoder (36). To select a folder, press the “Media Select” encoder. Once you select a folder, the mixer will enter song navigation mode and will display all of the playable songs in that folder. In song navigation mode, you can select a song by turning and pressing the “Media Select” encoder or by pressing the “Next” and “Previous” switches. If you were currently playing a song and selected a new song, the mixer will automatically start playing the new song. If you were paused or stopped, the mixer will select the new song and remain stopped. To fast forward a song, press and hold the “Next” switch, and to rewind a song, press and hold the “Previous” switch.

To go back to folder navigation mode, scroll all the way to the left and there will be an option called “FOLDERS”. Selecting this item will enter folder navigation mode, where you can select another folder of songs.

If a folder is selected that has no playable songs, “No Songs” will be displayed on the LCD. Scroll to the left and select “FOLDERS” to go back to folder navigation mode and select another folder.

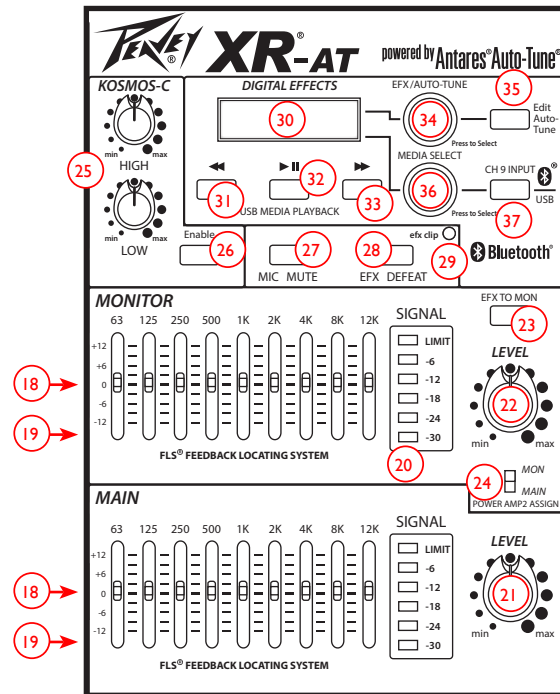

MASTER CONTROLS

18 FLS

When feedback occurs, the corresponding LED of the frequency that is closest to the frequency that is feeding back will illuminate the slider to be adjusted. Slowly bring the corresponding slider down until feedback is gone. The LED will remain illuminated for a few seconds after the feedback is gone. If the feedback doesn't return, all of the LEDs will become active again.

19 GRAPHIC EQ

These nine-band Equalizers are designed to either be used to reduce feedback or to adjust the overall frequency response of the signal being sent to the amplifiers. Subtle adjustments made with the graphic equalizer can improve the way your loudspeaker system sounds in the room. You should be aware however, that setting large amounts of boost or arbitrary curves can reduce amplifier headroom, leading to early distortion or just plain bad or unintelligible sound. Working with the FLS, the graphic EQ can also be used to reduce feedback. Each

band of EQ can supply up to 12dB of boost or cut.

20 LEVEL LED LADDER

These LEDs indicate the signal level of the main mix and the monitor mix. The top LED indicates LIMIT and activation of our revolutionary DDT speaker protection circuit. Peavey's award winning speaker protection is built into the XR-AT powered mixer and is activated automatically to maximize the power amplifier without fear of distortion.

21 MAIN LEVEL

The Main level control sets the level of the main mix and the overall volume of the powered mixer.

22 MONITOR LEVEL

The Monitor level control adjusts the level of the signal coming out of the Monitor send 1/4" jack (41). It can also be assigned to feed the 2nd power amplifier via the selector switch (24).

Master Controls

23 EFX TO MON

This switch toggles the EFX return signal being sent to the monitors. When it is lit, the effects signal is being sent to the monitors.

24 POWER AMP 2 ASSIGN

This switch allows the user to select the signal that is assigned to power amp 2 (49). The user can elect to send either the Main mix signal or the Monitor mix signal to the second internal power amplifier. This allows the user to run both power amps for mains or use power amp 1 for mains and power amp 2 for monitors.

25 KOSMOS-C

The Kosmos®-C uses special circuitry to enrich the sound of your system. This is not just a simple bass boost. It provides “natural bass enhancement” by adding harmonically related bass signals that track the envelope of the original signal. The Kosmos-C high control can be used to add clarity to dull signals.

26 KOSMOS ENABLE

When lit, the Kosmos enhanced signal is added to the main mix. This allows you to compare the enhanced signal with the dry with the press of a button.

27 MIC MUTE

Depressing this button mutes the mic/line inputs in all 8 channels. The media input jacks (RCA and 3.5mm) on channel 8 and the USB/BT inputs on channel 9 are still “live”. This allows you to play break music, while muting all of the microphone inputs.

28 EFX DEFEAT

This button mutes the effects being sent to the main mix, allowing the user to listen to a dry signal at the main outputs. When muted, the switch will be red. This can also be activated with a momentary footswitch. See (50).

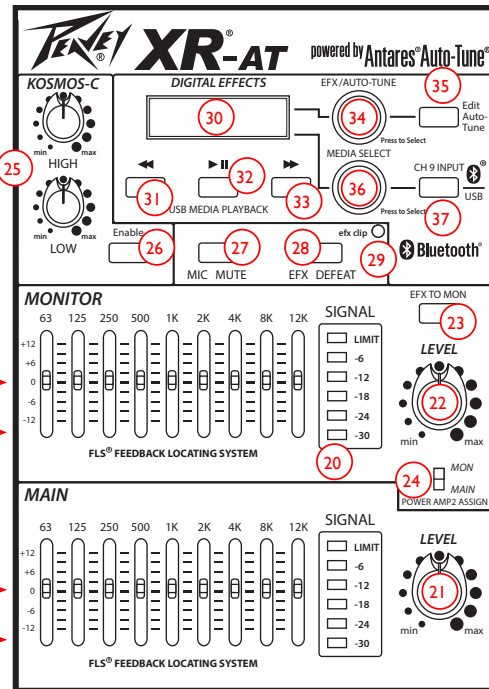

29 EFX CLIP

This LED blinks red when the signal being sent to the effects section is too high and is causing distortion. Find the source of the hot signal by reducing the EFX send (13) on each channel until the LED is no longer lighting (blinking red).

30 LCD DISPLAY

The top row of this LCD displays the currently selected EFX preset or Auto-Tune® preset and the bottom row displays the status of the media inputs of channel 9. If channel 9 is in USB Playback Mode, it can also be used for navigating the folders on the USB drive or displaying the current song playing.

31 REW/PREV

A short press will rewind to the beginning of the current song. Pressing this button twice will take you to the previous song on the USB drive. A long press will rewind through the current song; release to play when you reach the desired spot in the song.

32 PLAY/PAUSE

The play/pause button toggles the current song between play and pause. When the > II is displayed, the song will be playing. When II is displayed, the song is paused. When □ is displayed, the song is stopped.

33 FF/NEXT

A short press will advance the media player to the next song on the USB drive. A long press will fast forward through the current song; release to play when you reach the desired spot in the song.

34 EFX SELECT/AUTO-TUNE ADJUST

The EFX Select/Auto-Tune Adjust knob is a dual function control. It can be used to navigate and select the desired effect preset. In the Auto-Tune edit mode, it can be used to select presets and navigate the Auto-Tune edit functions. Please see the "Operating the DSP" section for further information.

Master Controls

35 EDIT AUTO-TUNE

The Edit Auto-Tune® switch is used to enter Auto-Tune editing mode. When it is engaged (lit), the current Auto-Tune preset will be displayed on the LCD. When it is disengaged (dark), the current EFX preset will be displayed on the LCD.

36 MEDIA SELECT

This encoder is used to control USB playback navigation. For more information on this, see “USB Playback.”

37 CH 9 INPUT SELECT (USB/BLUETOOTH)

This switch allows the user to select the input signal being sent to channel 9. It can select between the USB A connector or a wireless Bluetooth® connection from an external device (Smart phone, iPod, or tablet).

BLUETOOTH ACTIVE LED

The CH 9 INPUT button will also function as the Bluetooth Status LED. The blue backlit switch indicates the status of the Bluetooth connection. If the LED is off, the Bluetooth module is powered off and channel 9 is in USB Playback Mode. If the LED is slowly flashing, the XR-AT is not paired with any device, but is available for connection. When the LED is lit solid, the source device is properly paired to the mixer and ready to play.

BLUETOOTH OPERATION

To listen to music via the Bluetooth wireless connection, you must first pair (link) your XR-AT mixer with your Bluetooth phone and/or music device.

Turn off any Bluetooth devices previously paired with the XR-AT mixer.

Turn on the Bluetooth feature on your phone or music device.

Make sure the XR-AT is ready for a Bluetooth connection.

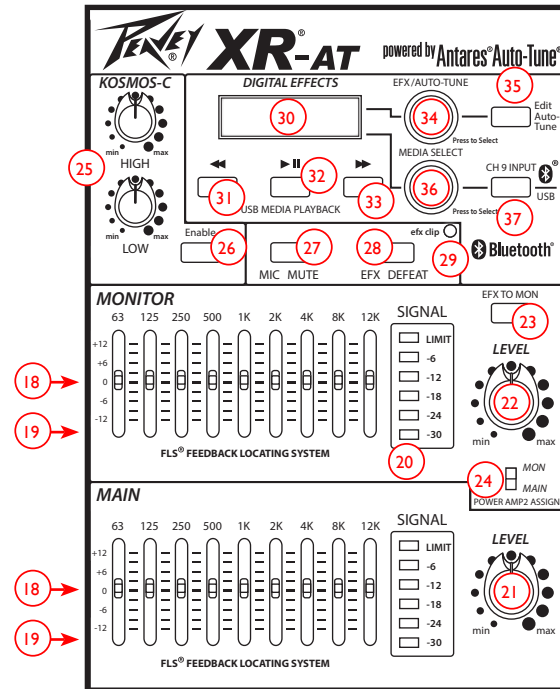

The Bluetooth Active LED should be blinking and the LCD will say, “Bluetooth Input.”

Place your phone or music device in Bluetooth search mode. The phone or music device will begin searching for the XR-AT.

Select “Peavey Mixer” from the search results on your phone or music device.

You will be prompted to enter a pin number. Enter the pin#, it is 7878 (or “PVPV” on a phone number pad).

If the pairing is successful, the Bluetooth Active LED will blink rapidly 5 times and then remain lit.

You are now ready to begin streaming through Bluetooth to the mixer. The level can be adjusted from the connected source or by the level control in Channel 9.

The XR-AT mixer will remember up to 10 devices that it was previously paired with and will automatically connect to the last device with

which it was paired when turned on. To clear the paired device memory, make sure the mixer is in Bluetooth mode and press and hold the Ch 9 Input Select Button (37) for 5 seconds. The XR-AT mixer will ask if you would like to clear the Bluetooth memory. Select “Y” using the Media Select knob to clear the memory. The XR-AT mixer will go through the process of clearing the memory, which should take approximately 15 seconds.

Auto-Tune Key Table
Key Display Note Number (n)=

Key	0	1	2	3	4	5	6	7	8	9	10	11
Chrom	C	C#	D	D#	E	F	F#	G	G#	A	A#	B
C Maj	C		D		E	F		G		A		B
C Mnr	C		D	D#		F		G	G#		A#	
C#Maj	C	C#		D#		F	F#		G#		A#	
C#Mnr		C#		D#	E		F#		G#	A		B
D Maj		C#	D		E		F#	G		A		B
D Mnr	C		D		E	F		G		A	A#	
D#Maj	C		D	D#		F		G	G#		A#	
D#Mnr		C#		D#		F	F#		G#		A#	B
E Maj		C#		D#	E		F#		G#	A		B
E Mnr	C		D		E		F#	G		A		B
F Maj	C		D		E	F		G		A	A#	
F Mnr	C	C#		D#		F		G	G#		A#	
F#Maj		C#		D#		F	F#		G#		A#	B
F#Mnr		C#	D		E		F#		G#	A		B
G Maj	C		D		E		F#	G		A		B
G Mnr	C		D	D#		F		G		A	A#	
G#Maj	C	C#		D#		F		G	G#		A#	
G#Mnr		C#		D#	E		F#		G#		A#	B
A Maj		C#	D		E		F#		G#	A		B
A Mnr	C		D		E	F		G		A		B
A#Maj	C		D	D#		F		G		A	A#	
A#Mnr	C	C#		D#		F	F#		G#		A#	
B Maj		C#		D#	E		F#		G#		A#	
B Mnr		C#	D		E		F#	G		A		B

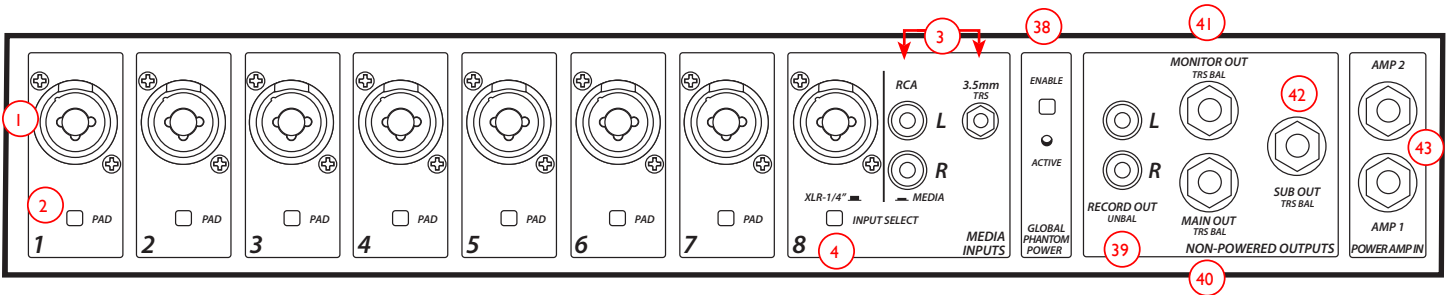

38 GLOBAL PHANTOM POWER
 This switch, when depressed, applies +48 VDC to all input XLR connectors to power microphones that need phantom power to work.



This switch applies +48 VDC voltage to the input XLR connectors to power microphones requiring phantom power. If phantom power is used, do not connect unbalanced dynamic microphones or other devices that cannot handle this voltage to the XLR inputs.

39 RCA RECORD OUT
 This pair of RCA jacks provides a signal to the recording inputs of a CD recorder, stereo tape deck or other recording device.

NOTE: Do not connect a single device to the Media Inputs (3) and Record Outputs. This improper setup forms a loop, which can cause severe feedback.

40 MAIN OUT (TRS Balanced)
 This 1/4" jack provides a signal from the main mix (after the graphic EQ) for an external power amplifier. An external power amplifier, such as our IPR® series of amplifiers, can then drive additional speakers.

41 MONITOR OUT (TRS Balanced)
 This 1/4" jack provides a signal from the monitor mix (after the graphic EQ) for an external power amplifier. An external power amplifier, such as our IPR series of amplifiers, can then drive additional speakers.

42 SUB/MONO OUT (TRS Balanced)
 This 1/4" jack provides a signal that passes all signals under 150Hz. This can be used to drive an external subwoofer amplifier or a powered sub. The level of signal tracks the main output.

43 POWER AMP INPUTS
 These are 1/4" inputs that allow an external line-level signal to be connected to each of the built-in power amps. Plugging an input into these jacks breaks the signal from the mixer to the built-in amplifier. The mixer output is still available at the Main out jack (40).

Rear Panel

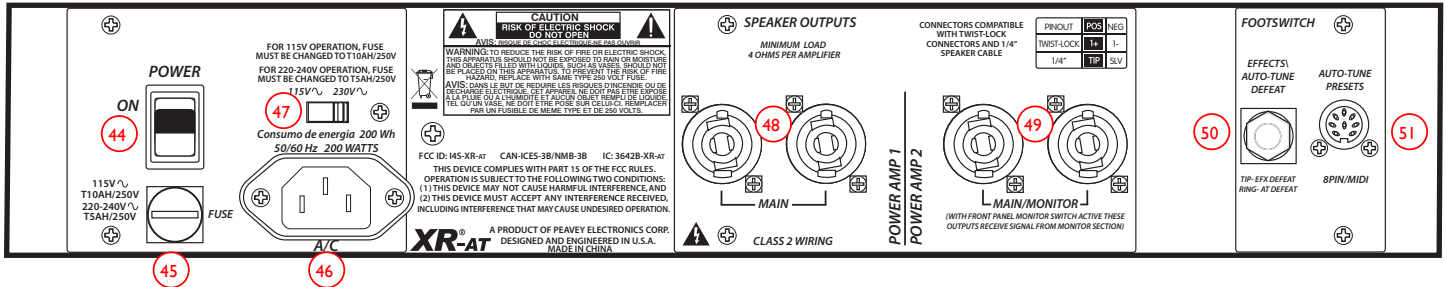

44 POWER SWITCH

This is the main power switch.

45 FUSE

This is the main safety fuse for the AC line voltage. Only replace with a fuse of the exact type and rating. If the fuse continues to open, do not over fuse. Take the unit to an authorized Peavey service center.

NOTE: If the main AC voltage is changed, the fuse must also be changed to one of the appropriate rating for the voltage you are switching to.

46 AC POWER INLET

This is the receptacle for an IEC line cord, which provides AC power to the unit. Connect the line cord to this connector to provide power to the unit. Damage to the equipment may result if improper line voltage is used. (See line voltage marking on unit.)

Never break off the ground pin on any equipment. It is provided for your safety. If the outlet used does not have a ground pin, a suitable grounding adapter should be used and the third wire should be grounded properly. To prevent risk of shock or fire hazard, always make sure that the amplifier and all associated equipment is properly grounded.

NOTE: FOR UK ONLY

As the colors of the wires in the mains lead of this apparatus may not correspond directly with the colored markings identifying the terminals in your plug, proceed as follows: (1) The

green and yellow wire must be connected to the terminal which is marked with the letter E, or by the earth symbol, or is colored green, or green and yellow. (2) The blue wire must be connected to the terminal which is marked with the letter N, or the color black. (3) The brown wire must be connected to the terminal which is marked with the letter L, or the color red.

47 VOLTAGE SELECTOR SWITCH

This switch allows the user to select between 115VAC / 60Hz or 230VAC / 50Hz. To change the voltage selector, you must first unscrew and remove the plastic cover that protects the switch. After changing the voltage, please replace the plastic cover to ensure the voltage level is not inadvertently altered.

NOTE: The fuse MUST be changed to the appropriate value to match the voltage you have selected. Please see the note on the back of the mixer for the correct value.

48 POWER AMP 1 SPEAKER OUTPUTS (MAIN MIX)

Dual two-conductor 1/4" – Speakon® combination jacks that can be connected to your speakers. Each amplifier has a minimum load impedance of 4 ohms. This means you can connect either one 4-ohm, one 8-ohm or two 8-ohm speakers to each amplifier. Do not operate below rated minimum impedance. For maximum power transfer and to prevent damage to your amplifier, be sure to use speaker cables and not instrument cables to connect to the speakers. We recommend the use of 18-gauge or larger speaker wire.

49 POWER AMP 2 SPEAKER OUTPUTS (MAIN MIX or MONITOR MIX)

Dual two-conductor 1/4" – Speakon combination jacks that can be connected to your speakers. Each amplifier has a minimum load impedance of 4 ohms. This means you can connect either one 4-ohm, one 8-ohm or two 8-ohm speakers to each amplifier. Do not operate below rated minimum impedance. For maximum power transfer and to prevent damage to your amplifier, be sure to use speaker cables and not instrument cables to connect to the speakers. We recommend the use of 18-gauge or larger speaker wire. The signal going to Power Amp 2 is determined by the position of the Power Amp 2 Assign switch (24). In the “MAIN” position, the main mix is fed to power amp 1 and power amp 2. In the “MON” position, the main mix is fed to power amp 1 and the monitor mix is fed to power amp 2.

50 FOOTSWITCH EFFECTS DEFEAT (TS)

This 1/4" jack accepts a momentary, dual - footswitch (Peavey Part# 03014070) designed to defeat the effects on all channels or toggle the Auto-Tune® on/off. Pressing switch 1 of the footswitch will toggle the effects on and off. The condition will be indicated by the EFX Defeat button on the front panel. When defeated, the button will be red. When the effects are active, the button will be dark. Pressing switch 2 will toggle the Auto-Tune on / off (globally). The status will be indicated by the three Auto-Tune on/off switches (5) at the top of the first 3 channels. If Auto-Tune is active, the switch will be amber. If it is inactive, the switch will be dark.

51 **AUTO-TUNE FOOTSWITCH**

MIDI In/Footswitch

This 8-pin DIN connector is provided for the connection of the Peavey 5-Button MIDI Footswitch. Preferably this should be connected before the mixer is powered up. See the “Peavey 5-Button MIDI Footswitch” section of this manual for a more detailed explanation of operation.

This can also be used as a MIDI IN connection, using a standard 5-pin MIDI cable, if the mixer is going to be controlled by a separate MIDI controller other than the Peavey footswitch. See the “MIDI” section of this manual for a more detailed explanation of the MIDI features.

PEAVEY 5-BUTTON MIDI FOOTSWITCH

The XR-AT Auto-Tune® can be controlled using the Peavey 5-Button MIDI Footswitch. Connect the footswitch to the XR-AT with the 8-pin MIDI cable provided with their footswitch. The 8-pin cable must be used because it provides power to the footswitch. The footswitch will initialize itself and reflect the current Auto-Tune preset selection. Below are the descriptions of each button on the Peavey 5-Button MIDI Footswitch for the XR-AT.

1 = Auto-Tune Enable/Disable (LED Green = Enabled, LED Red = Disabled)

2 = Preset Selector 1

3 = Preset Selector 2

4 = Preset Selector 3

5 = Preset Bank Selector (LED Off = Bank 1 , LED Red = Bank 2, LED Green = Bank 3)

Pressing the Auto-Tune Enable/Disable button will globally disable all Auto-Tune channels. This is useful when a performer is speaking between songs at a performance; the performer can disable the Auto-Tune while speaking into the microphone so that the XR-AT does not apply Auto-Tune to their speech. Pressing the switch again will enable the Auto-Tune channels that were enabled previously. If the Auto-Tune is globally disabled and one of the Auto-Tune channel buttons on the XR-AT mixer is pressed, the Auto-Tune will automatically globally enable but will only enable the Auto-Tune channel that was selected.

Buttons 2-4, the Preset Selector buttons, allow the performer to change Auto-Tune presets on-the-fly along with button 5, the Preset Bank Selector. Below is a table describing which Auto-Tune preset will be selected when using the Preset Selector buttons and the Preset Bank Selector button.

	BANK 1 (LED OFF)	BANK 2 (LED RED)	BANK 3 (LED GREEN)
Preset Selector 1	Preset 1	Preset 4	Preset 7
Preset Selector 2	Preset 2	Preset 5	Preset 8
Preset Selector 3	Preset 3	Preset 6	Preset 9

MIDI

The XR-AT Auto-Tune is also capable of being controlled with other types of MIDI controllers by using a standard 5-pin MIDI cable. It is capable of receiving Control Change messages and Program Change messages, as laid out by the MIDI standard. This is the information you need to use this mixer with other MIDI devices.

MIDI CC:

MIDI Control Change messages are used to change one function at a time. After selecting a preset (see MIDI Program below), modifications to that preset can be done with these messages.

Note: The XR-AT is designed to receive MIDI messages on MIDI Channel 1, so the first byte of every Control Change message should be **B0h**.

CONTROL	CONTROLLER NUMBER	DATA
Channel 1 Enable	01h	00h-3Fh (Off) OR 40h-7Fh (On)
Channel 2 Enable	02h	00h-3Fh (Off) OR 40h-7Fh (On)
Channel 3 Enable	03h	00h-3Fh (Off) OR 40h-7Fh (On)
N/A	04h	N/A
Speed	05h	00h-19h (0-25)
N/A	06h	N/A
N/A	07h	N/A
Detune	08h	00h-7Fh (0-127)

Example: B0 05 0F

Changes Speed to 15

MIDI PROGRAM:

MIDI Program Changes are used to recall Auto-Tune presets.

The XR-AT is designed to receive MIDI messages on MIDI Channel 1, so the first byte of every Program Change message should be **C0h**. The second byte should be the preset number minus one.

Example: C0 05

Recalls Auto-Tune preset 6

Effects (parameter)

PLATE (TIME)	DESCRIPTION	PREDELAY DAMP FACTOR	ROOM	ROOM SIZE	FRONT END HP	BACK END LP NAME	MORE DESCRIPTIVE
P1	Bright	35 ms					
P2	Gentle LP	48 ms					
P3	Med LP	62 ms					
P4	Hard LP	78 ms					
P5	Dark	95 ms					

HALL (TIME)							
H1	Vox Fox	35 ms	Med	Med	Subtle	Subtle	Med Hall
H2	Vox Huge	42 ms	Med	Large	Subtle	Subtle	Cathedral
H3	Vox Glow	10 ms	Med	Large	Subtle	Subtle	Auditorium
H4	Strings	30 ms	Med	Med	Subtle	Subtle	Concert Hall
H5	Brass Hall	35 ms	High	Med	Subtle	Moderate	Concert Hall 2

ROOM (TIME)							
R1	Vox Air	30 ms	Low	Small	Aggressive	Subtle	Hard Walls
R2	Vox Club	35 ms	High	Small	Subtle	Moderate	Club
R3	Snare Low	70 ms	Low	Small	Moderate	Subtle	Bathroom
R4	AC GTR	42 ms	Med	Small	Moderate	Subtle	Med Walls
R5	Brass Room	40 ms	High	Med	Subtle	Moderate	Med Room Damped Walls

DELAY (TIME)	
D1	Double
D2	Slapback
D3	Bright, Few Repeats
D4	Bright, More Repeats
D5	Bright, Most Repeats
D6	Dark, Few Repeats
D7	Dark, More Repeats
D8	Dark, Most Repeats

ENHANCE (CUTOFF FREQ)	
E1	Light Harmonics
E2	Moderate Harmonics
E3	Heavy Harmonics

CHORUS (RATE)	PREDELAY	CHORUS TIME	RATE	MODULATION
C1	10 ms	20 ms	0.1 - 1 Hz	Random Sine
C2	10 ms	5 ms	0.5 - 4 Hz	Random Sine
C3	10 ms	2 ms	0.5 - 6 Hz	Sine
C4	5 ms	1 ms	5 - 15 Hz	Random Sine
C5	2 ms	20 ms	0.2 - 3 Hz	Random Sine

Block Diagram

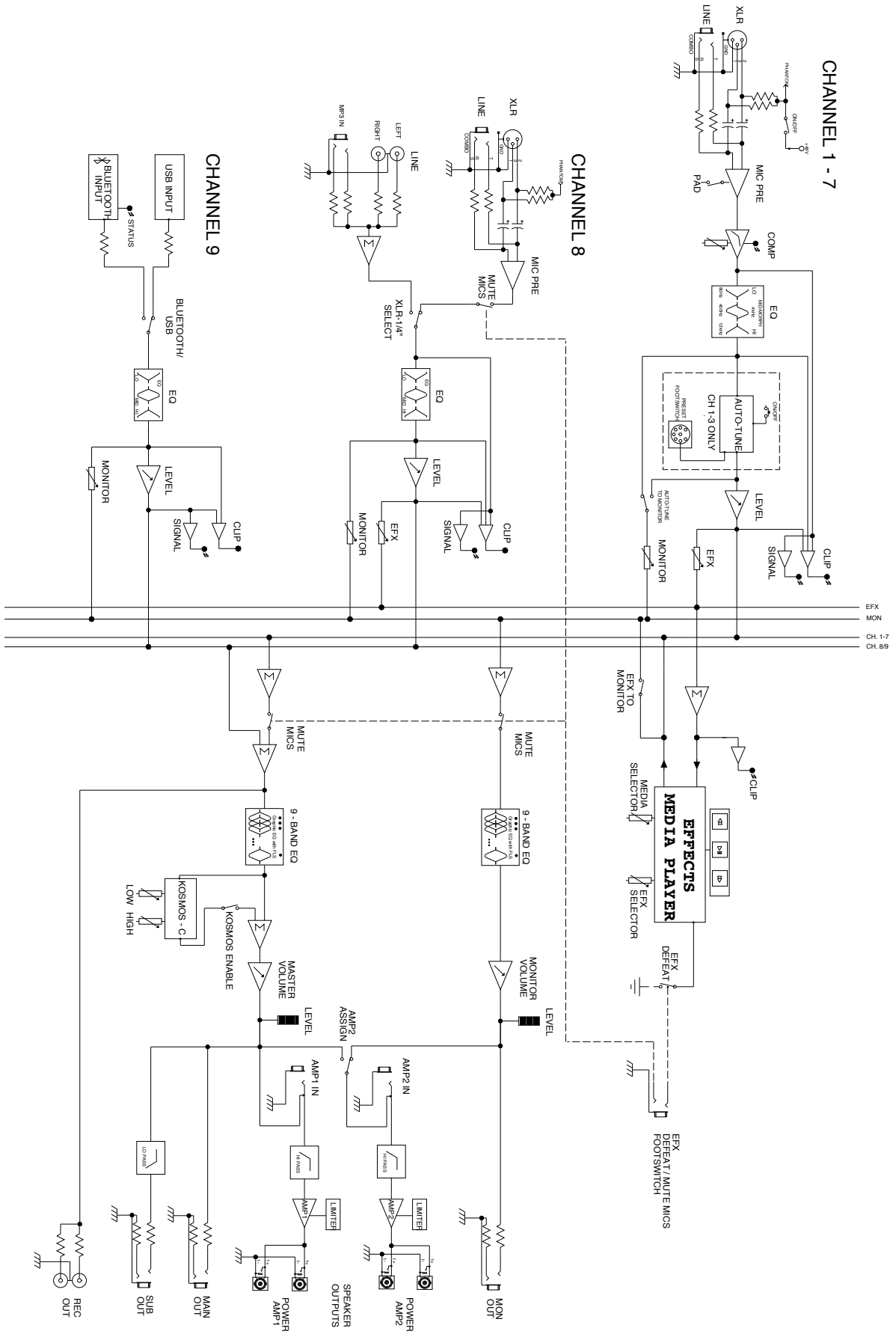

Specifications

INPUT SENSITIVITY:

Mic In to full power at the power amp. Master Volume Nom.		
Full	Nominal	
-40 dBu	-22 dBu	
Line In to full power at the power amp. Master Volume Nom.		
Full	Nominal	
-10 dBu	+8 dBu	

CHANNEL EQ:

Shelving EQ

Low EQ	80 Hz	±15 dB
Mid-Morph		
Low	250 Hz	±15 dB
High	4 kHz	±15 dB
High EQ	12 kHz	±15 dB

CLIP LED:

Clip LEDs come on 3 dB before clipping.

FREQUENCY RESPONSE:

All controls nominal (detent)

Mic to Main	20 Hz – 20 kHz	+0, -1 dB
Line to Main	20 Hz – 30 kHz	+0, -1 dB
Mic to Amp	50 Hz – 20 kHz	+0, -3 dB
Line to Amp	40 Hz – 20 kHz	+0, -3 dB

PHANTOM POWER:

+48 VOLTS

NOISE:

Main = Main line output, 22 – 22 kHz filter
Amp 1 = Amplifier output, loaded at 4 Ohms, through AP
AUX-0025 switching amplifier filter

All controls full down.	
Main	<-95 dBu
Amp 1	<-60 dBu
Master Volume nominal	
Main	<-88 dBu
Amp 1	<-55 dBu

THD:

All controls nominal

<0.01% @ main line output, -30 dBu in mic input Channel 1
<0.5% @ amp 1 @ 400 Watts into 4 Ohms

All controls nominal

<0.005% @ main line output, +4 dBu in line input Channel 1
<0.5% @ amp 1 @ 400 Watts into 4 Ohms

MASTER EQ:

80Hz	±12 dB
250Hz	±12 dB
500Hz	±12 dB
1kHz	±12 dB
2kHz	±12 dB
4kHz	±12 dB
10kHz	±12 dB

METER ARRAY:

LIMIT	
-6 dB	
-12 dB	
-18 dB	
-24 dB	
-30 dB	

AMP LIMITER:

Limits amplifier power just before clipping. The limiter holds the amp power without clipping and can be driven up to 18 dB past maximum output.

AMPLIFIER OUTPUT POWER:

120VAC

Both channels loaded at 8 ohms: 280 Watts RMS per ch

Both channels loaded at 4 ohms: 500 Watts RMS per ch

POWER REQUIREMENTS:

Domestic:	120VAC 50/60Hz	200 Watts Nominal
Export:	230VAC 50/60Hz	200 Watts

Nominal

SIZE:

Dimensions:	H x W x D
	9.5" x 19" x 9.5"
	24.13cm x 48.26cm x 24.13cm

WEIGHT:

16 lbs.
7.25 kgs

SUBPART J OF FCC RULES. THIS DEVICE COMPLIES WITH PART 15 OF THE FCC RULES. OPERATION IS SUBJECT TO THE FOLLOWING TWO CONDITIONS (1) THIS DEVICE MAY NOT CAUSE HARMFUL INTERFERENCE, AND (2) THIS DEVICE MUST ACCEPT ANY INTERFERENCE RECEIVED, INCLUDING INTERFERENCE THAT MAY CAUSE UNDESIRE OPERATION.



Features and specifications subject to change without notice.

Peavey Electronics Corporation • 5022 Hartley Peavey Drive • Meridian, MS • 39305
(601) 483-5365 • FAX (601) 486-1278 • www.peavey.com • 31700107 • ©2015



Logo referenced in Directive 2002/96/EC Annex IV (OJ(L)37/38,13.02.03 and defined in EN 50419:2005
The bar is the symbol for marking of new waste and is applied only to equipment manufactured after 13 August 2005

Optional Product Extended Warranty Registration

Give us some information and put your extended warranty into effect!

Please take a few minutes to fill out this information/survey sheet to help us get to know and serve you better.

To save time, submit your warranty registration online at www.peavey.com/support/warrantyregistration

1.

First Name _____ Initial _____ Last Name _____

Street Address _____

City _____ State/Province _____ Postal Code _____

() _____
Telephone Number _____ E-mail Address _____

() _____
Fax Number _____ Date of birth _____

Gender M F

2.

Model _____ 8-Digit Serial Number

Date of Purchase _____ Price Paid _____

3.

Name of store where purchased _____

City _____ State _____

4. Top two (2) reasons why you purchased from this store/dealer:

- | | |
|---|--|
| <input type="checkbox"/> Availability of product | <input type="checkbox"/> Past favorable experience |
| <input type="checkbox"/> Friend/Relative's recommendation | <input type="checkbox"/> Best price |
| <input type="checkbox"/> Store credit card | <input type="checkbox"/> Advertised special |
| <input type="checkbox"/> Knowledgeable staff | <input type="checkbox"/> Convenient location |
| <input type="checkbox"/> Availability of lessons | <input type="checkbox"/> Received as a gift |
| <input type="checkbox"/> Technical instruction | <input type="checkbox"/> Other _____ |

5. Where do you most often shop for music and sound products?

- | | |
|---|---|
| <input type="checkbox"/> Independent retailer | <input type="checkbox"/> Newspaper ads |
| <input type="checkbox"/> Mass market retailer | <input type="checkbox"/> Internet/Web sites |
| <input type="checkbox"/> Mail order magazines | <input type="checkbox"/> Other _____ |

6. What two (2) factors most influenced your purchase of this product?

- | | |
|--|---|
| <input type="checkbox"/> Peavey brand name | <input type="checkbox"/> Product appearance |
| <input type="checkbox"/> Craftsmanship | <input type="checkbox"/> Durability |
| <input type="checkbox"/> Features for price | <input type="checkbox"/> Prior experience with Peavey |
| <input type="checkbox"/> Bundled accessories | <input type="checkbox"/> Packaging |
| <input type="checkbox"/> Sound quality | <input type="checkbox"/> Other _____ |

7. How did you learn about this Peavey product? (select best answer)

- | | |
|---|---|
| <input type="checkbox"/> Magazine review | <input type="checkbox"/> Teacher's recommendation |
| <input type="checkbox"/> Newspaper review | <input type="checkbox"/> Catalog or flyer |
| <input type="checkbox"/> Radio advertisement | <input type="checkbox"/> Saw in store |
| <input type="checkbox"/> Advertised special | <input type="checkbox"/> Use by professional |
| <input type="checkbox"/> Friend/Relative's recommendation | <input type="checkbox"/> Other _____ |
| <input type="checkbox"/> Salesperson's recommendation | |

8. Which other brands/models did you consider?

9. How would you describe your level of musicianship/technical expertise?

- Beginner - Never played or taken less than one (1) year of lessons
 Intermediate - One (1) to five (5) years of lessons or playing
 Advanced - More than five (5) years of lessons or playing; play professionally

10. Education: (select best answer)

- High school
 Some college
 Completed college
 Graduate school

11. Which best describe your family income? (select best answer)

- | | |
|--|--|
| <input type="checkbox"/> Under \$15,000 | <input type="checkbox"/> \$75,000 - \$99,999 |
| <input type="checkbox"/> \$15,000 - \$24,999 | <input type="checkbox"/> \$100,000 - \$149,999 |
| <input type="checkbox"/> \$25,000 - \$34,999 | <input type="checkbox"/> Over - \$150,000 |
| <input type="checkbox"/> \$35,000 - \$49,999 | |
| <input type="checkbox"/> \$50,000 - \$74,999 | |

12. Which of the following is your primary source of information on musical products: (select best answer)

- | | |
|-------------------------------------|---|
| <input type="checkbox"/> Television | <input type="checkbox"/> Mail order catalogs |
| <input type="checkbox"/> Radio | <input type="checkbox"/> Direct mail |
| <input type="checkbox"/> Internet | <input type="checkbox"/> Literature from manufacturer |
| <input type="checkbox"/> Newspaper | <input type="checkbox"/> Other _____ |
| <input type="checkbox"/> Magazines | |

13. What is your main motivation for buying new equipment?

- | | |
|--|--|
| <input type="checkbox"/> Replacing old product | <input type="checkbox"/> Impulse |
| <input type="checkbox"/> Want new and leading edge equipment | <input type="checkbox"/> Need for improved performance |
| <input type="checkbox"/> Fullfill a specific need | <input type="checkbox"/> New technology |
| <input type="checkbox"/> Supplement existing products | <input type="checkbox"/> Availability of product |
| <input type="checkbox"/> Value | <input type="checkbox"/> Other _____ |

14. Please list your three most frequently visited Web sites.

1. http:// _____
 2. http:// _____
 3. http:// _____

15. In your opinion, what could Peavey do to improve its products and/or service? Please use the space below to tell us your answer.

Thank you for taking the time to fill out our survey! Don't forget to fold and tape (with Peavey address facing out), affix postage stamp and drop in the mail!



Logo referenced in Directive 2002/96/EC Annex IV (OJ(L)37/38,13.02.03 and defined in EN 50419: 2005
 The bar is the symbol for marking of new waste and is applied only to equipment manufactured after 13 August 2005



Peavey Electronics Corporation
Attn: Warranty Department
P.O. Box 1150
Meridian, Ms 39302-1150



FROM:

Place
Postage
Here