



CS-400™

OPERATING GUIDE

GENERAL DESCRIPTION

The field proven CS-400™ has been designed for commercial duty amplification where performance, reliability and long life are foremost requirements. Over the years, Peavey has continually refined the circuitry of the CS-400™ using the latest advances in circuit design technique and semiconductors. In this reliable high performance unit, we have combined the latest in high slew rate integrated circuits in the front end with the most rugged high-speed power transistors available in the output. The electronic sophistication and the unique modular packaging, together with a completely prefabricated wiring harness, constitute a system featuring performance, reliability and simplicity.

The CS-400™ utilizes a total of sixteen power transistors mounted on massive fan-cooled heatsinks. The CS-400's™ thermal system minimizes stress on each output device by distributing the total load over a large number of output devices and the automatic two-speed forced air cooling system insures low operating temperatures in any given environment to assure long, trouble-free operation.

This potent package now features Peavey's DDT (Distortion Detection Technique) compression circuitry that electronically senses the onset of clipping and engages a specially designed circuit which virtually eliminates the possibility of driving the amplifier into distortion. Our many years of field experience has proven that the main cause of speaker/driver failure is generally due to a system's power amplifier being overdriven, thus supplying clipped wave form (square waves) to the speaker system. A square wave is generally very destructive to speaker systems for many reasons, one being its extremely high D.C. content which greatly increases the average power delivered to the speaker, as well as the steep wave fronts and high harmonic content of these signals. Our DDT compression circuit may be disengaged if desired by the push/pull switch which is the integral part of the level control for each channel.

The CS-400™ features a unique patch system for each channel enabling the use of various plug-in accessories such as balanced input transformers and electronic crossovers. Professional design, specifications and "in-process" quality checks combine to produce an amplifier with honest performance at a reasonable price; but we don't stop here. We realize that even the most conservatively designed power amplifier will occasionally fail. Such occurrences are indeed unfortunate, but the real loss is usually discovered later when it becomes apparent that the amplifier failure has destroyed the speaker system. The Peavey CS-400™ has a built-in protection circuit in each channel to avoid this problem. A triac, the device commonly used in light dimmers, is employed in an "electronic crowbar" circuit connected across the speaker terminals of each channel. Under normal signal conditions, including full power output down to 20 Hz, this circuit remains inoperative. However, with the advent of abnormal D.C. voltages on the output terminals, the triac fires thereby placing a short circuit "electronic crowbar" across these terminals. This effectively shunts any D.C. voltage harmless to ground rather than to the speaker system. This circuit is an electronic insurance policy. It's there to protect the speakers when they need it the most.

As a home hi-fi amplifier, the Peavey CS-400™ is an unmatched stereo power amp. However, a word of warning should be given concerning the choice of the speaker system used. A true 200 watts per channel can easily destroy many home loudspeaker systems.

The operation of the CS-400™ is essentially straightforward and will present no difficulties in most applications. Our exclusive DDT compression circuitry enables the total system to enjoy freedom from most of the commonly encountered headroom problems with power amplifiers. The convenience of the rear patch panel, combined with the optional low cost plug-in accessories, give the CS-400™ unmatched versatility. The CS-400™ continues to be one of the most competitive professional power amplifiers on the market on a dollar-per-watt/performance basis. Professional specifications, components, the latest semiconductors and contemporary design make the CS-400™ the obvious choice for demanding commercial/professional applications. Comparison of performance, features, construction, techniques, and quality of components with any of its competition will illustrate the excellence of this professional amplifier.

WARNING
TO PREVENT ELECTRICAL SHOCK OR FIRE HAZARD, DO NOT EXPOSE THIS APPLIANCE
TO RAIN OR MOISTURE. BEFORE USING THIS APPLIANCE, READ BACK COVER FOR
FURTHER WARNINGS.

INSTALLATION AND CONNECTION

The Peavey CS-400™ Commercial Series power amplifier is designed for durability in commercial installations and delivers the quality of performance required in studio and home applications. The CS-400™ is a dual channel power amplifier with each channel capable of delivering more than 200 watts RMS into a 4-ohm load. The amplifier is of the standard 19" rack mount configuration and is cooled by an automatic two-speed internal fan.

Industrial and Commercial Installation

For commercial and other installations where sustained high power operation is required, the amplifiers should be mounted in a standard 19" rack with one standard rack space (1 3/4") between each amplifier in the stack. It should be noted that the fan pulls air in from one side and exhausts the hot air through the opposite side and top cover. It is for this reason that one rack space must be left between the units. Adequate air supply must be provided for the amplifiers when rack mounted. The internal fan must have a source of air that is not preheated by other equipment. The fan may be operated at high speed continuously to provide better cooling situations at all times. If fan cooling is inadequate due to preheated air or reduction of air flow, an internal thermal breaker may cause temporary shutdown of the amplifier. This is indicated by the front panel high temperature lamp (4). As a general rule, the cooler electronic equipment is operated, the longer its useful service life. You have invested in the finest equipment that money can buy and a little care will insure long and reliable operation.

Studio and Home Installation

In most low to medium power applications, the power amplifier can be mounted in almost any configuration. It is desirable that, if at all possible, the power amplifier be located at the top of an equipment stack. This will prevent possible drift or overheating of sensitive equipment from the hot air rising from the power amp. As a general rule, most home requirements will never cause the fan to switch to the high speed mode. Inadvertent short circuit or sustained high power usage, however, will cause high speed fan operation and could cause thermal shutdown.

Input Connections

All input connections are made at the rear panel jacks. The two jacks marked "Channel Inputs" (11) are wired in parallel for ease of connecting several amplifiers. Shielded cable must be used to minimize hum and noise pickup. The nominal input impedance is 50K Ohms. This impedance represents a bridging load to professional equipment and is compatible with the load requirements of home stereo devices. The CS-400™ has an input sensitivity of 1 volt RMS for rated output with the front panel level set at "10" allowing complete compatibility in home applications. This sensitivity decreases at lower level settings. It is generally wise to operate the level control at "7" or greater.

Output Connections

Two types of output connections are provided on the rear of the power amplifier modules. Two standard 1/4" phone jacks (12) and one set of binding posts (13) are available from each channel. Due to the high currents (greater than 10 amps) at full output, it is recommended that No. 16 or larger wire be used whenever possible. Smaller wire sizes will waste power and yield less than optimum results at the speaker.

It is also suggested that in commercial and other non-portable applications, the binding posts (13) be used instead of the 1/4" phone plugs. The binding posts are an industry standard and mating banana plugs are available from most electronic distributors. As with all electronic equipment, proper phasing of the outputs is important. A little time spent in correctly identifying the wiring could save a lot of problems in the field.

OPERATION

The CS-400™ Commercial Series power amplifier is designed for maximum ease and flexibility of operation. When the unit is installed and connected as described in the previous sections, operation is simply turning on the main switch and turning up the front panel level controls for the desired output level or until the front panel overload LED shows that the amplifier is clipping or compressing.

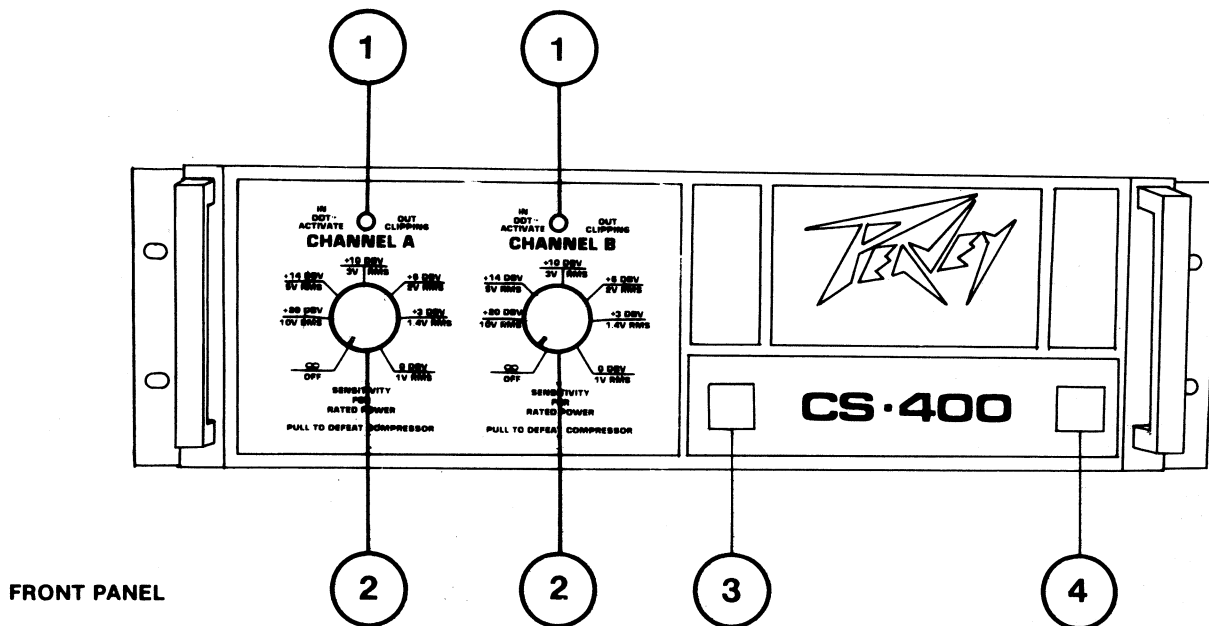

FRONT PANEL

DDT® COMPRESSION

The CS-400™ is a compact and powerful amplifier that features a new type of dynamic compression. This compression system enables the user to maximize the performance of the amplifier/speaker combination. We have determined through much research that the compression circuitry should prevent the power amp from running out of headroom (clipping) and should be as simple to operate as possible to avoid undue complication for the user. The compression system is activated by our exclusive "Distortion Detection Technique" circuit (DDT®) that senses conditions which might overload and activates compression when clipping is imminent. In other words, compression takes place whenever signal conditions exist which prevent the amplifier from faithfully reproducing the input signal. The threshold is the clipping level itself and no specific threshold control is provided. This technique effectively utilizes every precious watt available from the power amp. Because of the dynamics of music and vocals, it is quite common to activate the compression circuitry virtually constantly during a performance since this is what it is designed to do, i.e., to maximize the dynamics available from the amplifier within its power output capabilities regardless of power supply/line voltage variations and load impedance selection.

CLIPPING/COMPRESSION LED INDICATOR

The clipping/compression LED (light emitting diode) indicator (1), with the compressor operational, indicates when compression takes place. As long as gain reduction is occurring, the LED will continue to light thereby giving a valuable indication of this unique compression function. When the compressor is defeated by pulling out the level control on the associated channel (2), the LED now indicates a condition called "clipping." This condition is simply the failure of the amplifier to faithfully reproduce the input signal. Clipping can be caused by low line voltage, shorted speaker cables, or simply overdriving the amplifier with too much signal. In any event, the LED will light when this occurs and it has a short memory circuit built in to give the soundman a positive indication. The LED indicator will light during every clipping situation, thereby providing a valuable tool to help prevent severe distortion of the CS-400™. This type of indicator is more valuable than a conventional VU meter because a VU meter tends to ignore occasional peaks and only responds to relatively long term signals.

INPUT SENSITIVITY CONTROLS

The CS-400™ has the level controls for each channel labeled in a more functional manner replacing the conventional 0 to 10 segmented circle with the actual input sensitivity ratings of the amp for various settings of this control. In the past, this control has often confused even the most experienced audio technician as to its purpose and usage. This new change will help to explain its function, the need for these controls and the significance of the sensitivity rating.

The input sensitivity rating of a power amplifier is the RMS voltage level required at the input to produce full power into the rated load at the output. **This voltage then becomes the level at which the associated mixer must operate in order to produce the rated full power output.** Operation at levels above this rating will cause the power amplifier to clip (produce distortion) unless the associated amplifier has a compressor or limiter to minimize this distortion. Such a system called "DDT®" (U.S. Patent #4,318,053) is available on all Peavey power amplifiers and the advantages should be obvious...without it the sound engineer must "ride gain" on the mixer in order to prevent the mixer from producing an output signal level above the input sensitivity rating of the power amplifier which would cause distortion.

Traditionally the input sensitivity rating of a power amplifier receives low "billing" on a typical specification sheet. Usually the power output levels into various loads and the distortion numbers are first, followed by various other "interesting" specs, such as damping factor, slew rate, transient intermodulation distortion, and others. Then, in the fine print, one might find the input sensitivity rating...then again, one might not. **This rating, however, must be known to have performance visibility at the mixer.** Further, the rated sensitivity is only correct if the power amplifier level control is set at the **full clockwise or maximum setting.** Any other setting increases the value. With a numbered circle from 0 to 10, this new higher value is not indicated. The sensitivity ratings of the CS-400™ (and CS-800™) is to make the sensitivity rating known and to allow it to be adjusted accurately to higher values if necessary. You will notice that the sensitivity ratings are specified in both RMS voltage levels (usually given in power amp spec sheets) and the equivalent dBV values (usually listed in typical mixer specs). The dBV values are more useful since most contemporary mixers employ LED arrays, calibrated in sensitivity rating in dBV, indicating mixer output levels. Knowing the power amplifier sensitivity rating in dBV will allow the mixer operator to know the status of his power amplifiers (whether they are clipping or not) by noting which LED on the mixer is "peaking". Obviously the LED labeled the same or closest to the sensitivity rating will indicate full power output of the system. **Operation below that point will indicate how much so called "power amplifier headroom" is left. Operation above that point will cause clipping (or compression if the Peavey DDT™ system is in use).** Perhaps an example will be helpful here. Referring to the CS-400™ faceplate you will notice that with the amplifier "sensitivity for rated power" control set full clockwise, the rating is 1.0V RMS or 0 dBV. The critical LED on the driving mixer then is the one labeled 0 dBV. It will correlate with the power amplifier clipping/compression LED in that, whenever the 0 dBV LED on the mixer flashes on peaks, **the LED on the power amplifier will also flash indicating full power output is achieved.** If the CS-400™ control were adjusted to a higher value, then this new value would become the new correlation point on the associated mixer. This, then, is the main reason for knowing the value of the power amplifier sensitivity.

There is a very simple "rule" regarding the setting of the sensitivity (or level) control on a power amplifier. The "rule" is:

"UNLESS THERE IS A SPECIFIC REASON NOT TO, THE SENSITIVITY CONTROL ON ANY POWER AMPLIFIER SHOULD BE SET TO THE FULL CLOCKWISE POSITION, RESULTING IN THE MINIMUM VALUE OF SENSITIVITY RATING."

The exceptions to the full clockwise "rule" involve large systems where it is often necessary to employ several power amplifiers supplying the same signal to multiple speaker systems to achieve the necessary sound pressure levels or audience coverage. If the various amplifiers have different sensitivity ratings, it is necessary to adjust them to all have the same value so they all reach full power at the same time. A typical example is using a CS-400™ and a CS-800™ on the same mixer signal output. The CS-400™ is rated at 0 dBV, while the CS-800™ is rated at +3 dBV (the CS-800™ has 3 dB more power thus requiring 3 dB more signal input). To achieve simultaneous full power operation, the CS-400™ should be adjusted to +3 dBV. Notice the CS-800™ must be set full clockwise. The resulting system will have 15 dB of compression capability. Several competitive power amplifiers on the market have sensitivity ratings of +6 dBV (2V RMS). If these are employed in multiple systems, obviously, the more sensitive power amps must be adjusted accordingly.

In order to achieve the necessary sound pressure levels required in the typical "rock'n roll" concerts for the sound system, the use of bi-amped and tri-amped systems has become very popular and necessary. In this case, a crossover system must be employed between the mixer output and the various power amplifier systems in order to achieve 2 or 3-way operation with the associated loudspeaker components. Often these crossover systems provide adjustments for the crossover frequencies but have no level adjustments on the various outputs to compensate for differences in efficiency ratings of the various loudspeaker components. In this case, the sensitivity control can be adjusted upward on the particular amp the amount necessary to "pad" the associated speaker component in order to achieve a "flat" system. Naturally for optimum compression performance, the "unpadded" power amplifier should be set full clockwise.

Here at Peavey, we have chosen a unique plug-in crossover system, used in conjunction with our so-called "crossover islands" on the CS-400™ and CS-800™, to achieve bi-amped and tri-amped systems easily and at a low cost to the user. For each of our "bi-ampable" speaker systems we offer a matching crossover "can" which is specifically designed for that speaker system and contains all the necessary "padding and equalization" to achieve a "maximally flat" system. In this case, again, the sensitivity controls on the associated power amplifiers must be set at the full clockwise setting to achieve optimum performance. We also offer general purpose crossovers for competitive speaker enclosures which do not contain padding or equalization (referred to as "flat" crossovers) and, in this case, the power amplifier sensitivity controls or some other means must be employed to accomplish the necessary padding requirements.

One final point on setting power amplifier sensitivity controls...often, especially in small clubs, churches, and studio applications, the full power output capability of the power amplifier is not needed, or at the very most, there is no requirement for large amounts of compression capability due to the relatively low signal levels involved. Simultaneously these applications usually require a very low noise system. In this case it is possible to reduce the overall system noise at the expense of compression capability by increasing the power amplifier sensitivity accordingly. In other words, if instead of a sensitivity rating of 0 dBV on the Peavey CS-400™, we adjusted it to a rating of +10 dBV, overall system noise would be improved by 10 dB with the resulting compression capability of 8 dB. In other words, this can be one good reason for increasing the power amplifier sensitivity rating. Remember, however, once this is done, the mixer operator cannot re-establish full compression performance sitting at the mixer. If he wants it back, he has to do it at the power amplifier.

"ON/OFF" SWITCH/PILOT LAMP

The front panel of the CS-400™ contains a conventional type "ON/OFF" switch (3) with an internal pilot lamp. When the amplifier is plugged into a suitable power source, activating this switch should light the pilot indicator lamp. Failure of the pilot lamp to come on may indicate the line fuse has blown or the power source is faulty.

FAN SPEED SWITCH/HIGH TEMP. INDICATOR

The fan speed switch (4) determines the speed of the internal cooling fan with the internal lamp indicating over-temperature shutdown conditions. For most applications, low speed operation will provide adequate cooling. However, for sustained high powered applications, manual selection of high speed operation is recommended to provide maximum cooling, thereby minimizing the possibility of any shutdown of power due to over temperature conditions. The CS-400™ contains an internal thermal sensor that automatically raises the fan speed to high if low speed was selected when conditions exist which require additional cooling. Even at high speed operation, however, overloads into very low impedances and inadvertent short circuits could result in very high temperature conditions and the amplifier's thermal overload circuit may activate. This will be obvious with the pilot lamp off and the high temperature indicator on. The cooling fan will remain on as long as the unit is plugged in. After the unit has cooled down sufficiently, the amplifier will automatically cycle back on again. If high ambient temperature conditions exist, such as in a closed area,

the fan should be operated on the high speed position. For normal home use, the high speed fan operation might be objectional due to excessive fan noise. In this case, the low speed should be selected. In any event, reliable operation is assured even if low fan speed was selected due to the internal thermal sensor system which will automatically raise fan speed and ultimately set the high temperature limit of each heatsink. Care must be taken to avoid any blockage of the fan itself or the exhaust ports at the side of the unit.

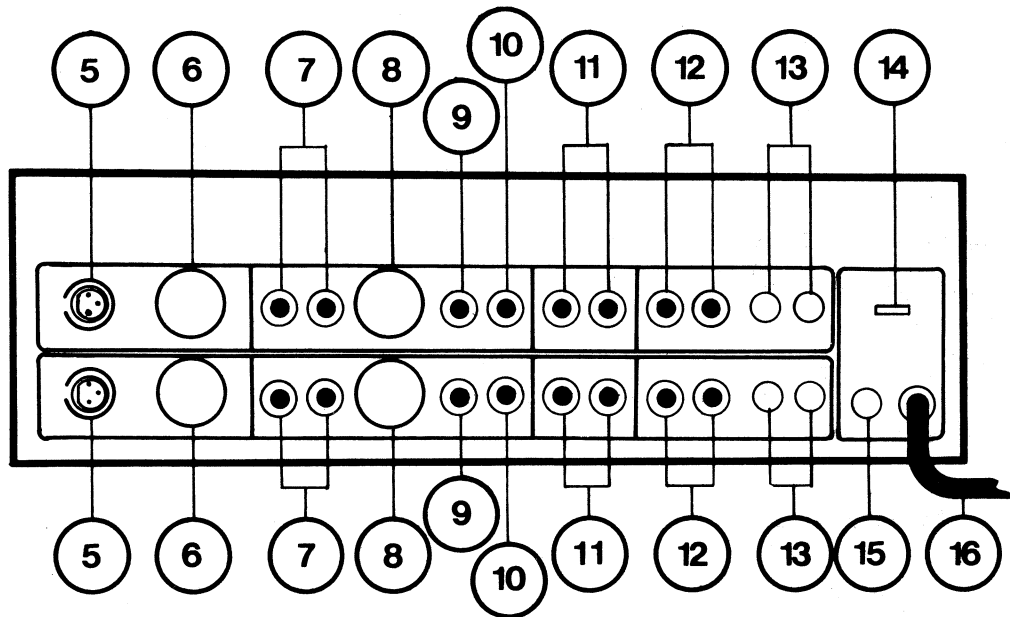

REAR PANEL

MODE SWITCH

The mode switch (14) located on the rear panel should normally be in the **stereo position**. Unless the amplifier is to be used in a commercial sound distribution (70-volt line) system, the bridge mode **should not** be used. **In certain crossover applications, accidental switching to the bridge mode could destroy the speaker systems.**

The CS-400™ power cord (16) is a heavy-duty type with a conventional A.C. plug with a ground pin. It should be connected to a circuit capable of at least 15 amps continuous, or greater. If the socket used does not have a ground pin, a conventional adaptor should be used and the third wire grounded properly. Never break off the ground pin on a line cord of the CS-400™. The use of extension cords should be avoided, but if necessary, always use a three-wire type with at least a No. 16 wire size. The use of lighter wire will severely limit the power capability of this amplifier.

The CS-400™ is fused with a standard 8-amp fuse (15). Always replace with the same type and rating. Failure to do this could void the warranty.

PATCH PANEL

The crossover patch panel of the CS-400™ provides the user with a very flexible system to facilitate the use of balanced inputs and dual crossover networks. These features are unduplicated in any other stereo power amp on the market today.

A simplified functional diagram is printed on the top cover of the CS-400™ showing the four basic modes of operation. These diagrams also appear in this manual for discussion purposes.

The CS-400™ is shipped from the factory with jumpers placed in the transformer accessory and crossover accessory sockets. These jumpers are necessary if the low impedance input connectors (5) are to be used. As indicated in Diagram 1, the XLR type connectors (5) are wired in an unbalanced configuration. (Pins 1 and 2 are ground, pin 3 is the input.) The unbalanced input configuration is acceptable whenever relatively short cable runs are employed, or when the mixing system used has a **transformer** coupled output. This configuration will provide adequate hum and

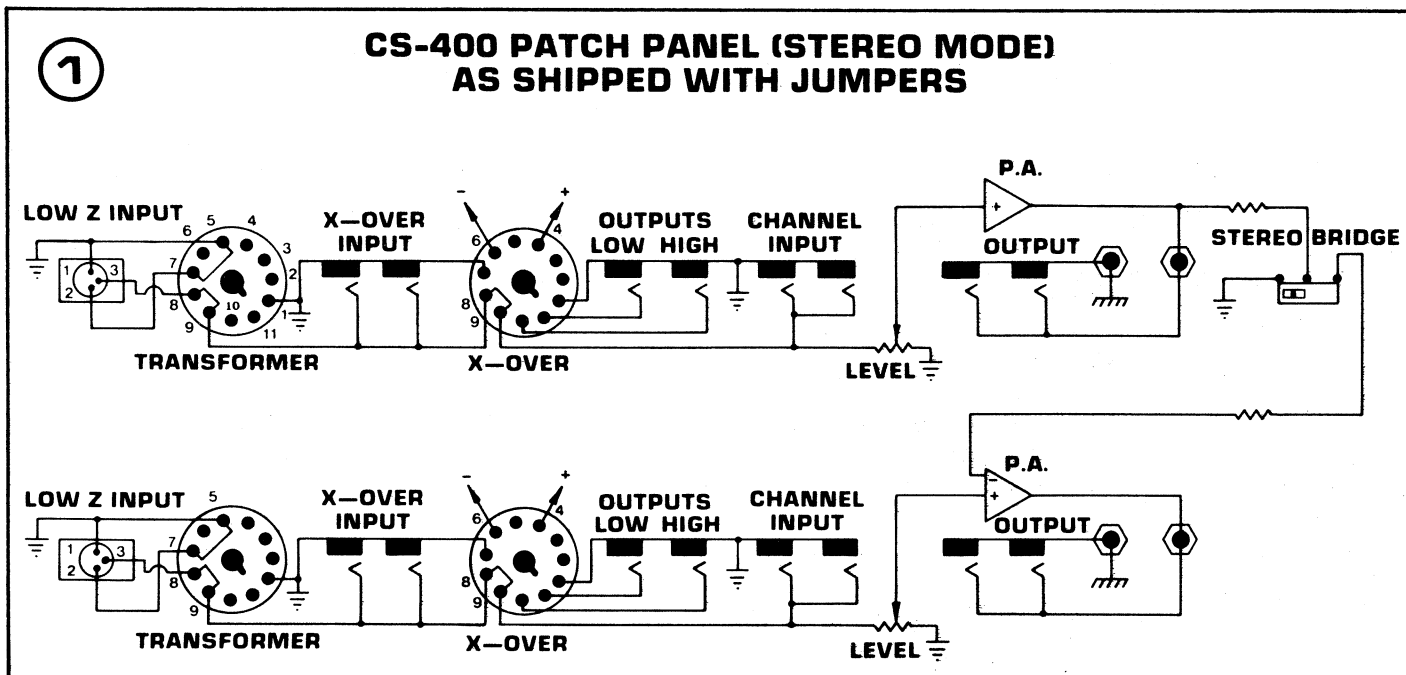

2

CS-400 PATCH PANEL (STEREO MODE) WITH BAL. INPUT TRANSFORMER MODULES

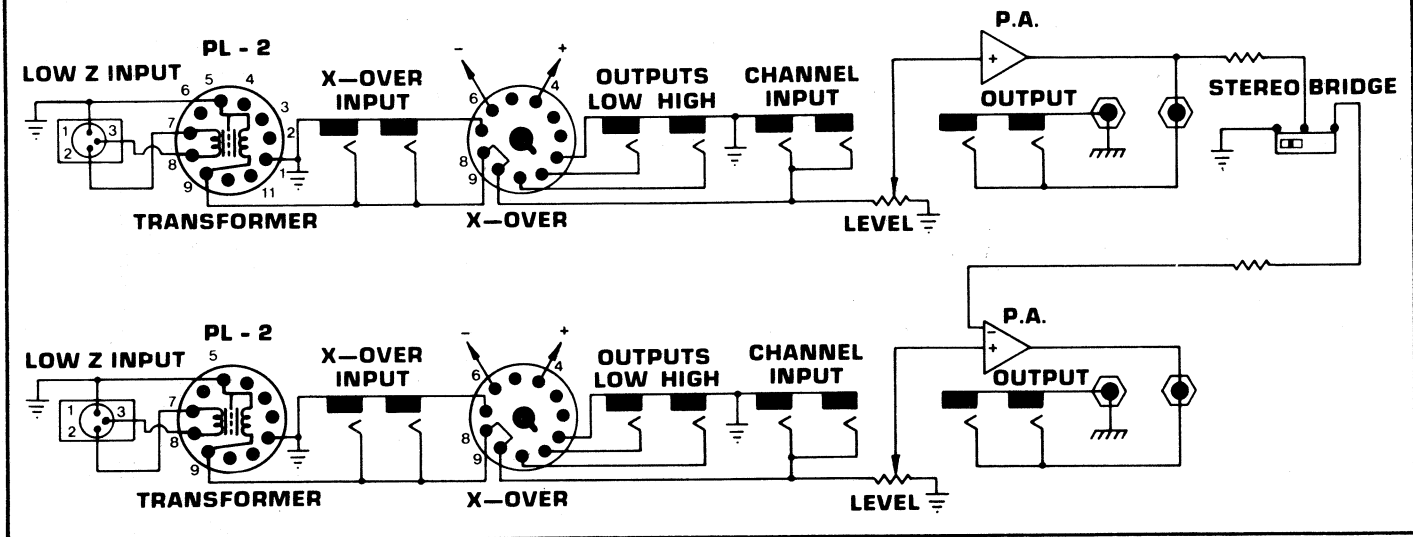

interference cancellation. When conditions require the use of a balanced input at the amplifier, the XLR connectors (5) on either or both channels can be converted to a balanced configuration by removing the jumpers supplied, and plugging an input transformer module (PL-2™) into the transformer accessory socket (6). The Peavey Model PL-2™ transformer module is a nominal 600 to 600 ohm type, resulting in unity gain. As indicated by Diagram 2, the XLR connector is now wired as a standard balanced type input (Pin 1 is ground, pin 2 is negative, pin 3 is positive.) The parallel input jacks (7) previously discussed are connected **after the transformer** and can be used to patch to other inputs, including the other channel of this amplifier if desired.

When balanced stereo operation is desired, two PL-2™ modules are required. However, for monaural operation (the same signal is applied to both channels), only one PL-2™ is needed. A shielded jumper cable is then connected between one of the Channel A input jacks (11) to one of the Channel B input jacks (11). The XLR connector on the channel with the transformer module is balanced. The other channel XLR connector should not be used.

If desired, the Peavey CS-400™ patch panel can be used to provide stereo bi-amplification operation. Electronic crossover modules for 500 Hz (PL-6™) and 750 Hz (PL-7™) are available; an SP-1™ crossover is also available (PL-8™), providing special equalization for this unique speaker system. Additional plug-in modules will become available in the future for other specialized systems.

BI-AMPLING

There are many good reasons for using a bi-amplified professional system as opposed to a system with traditional high-level crossovers. One reason is that a bi-amplified system can actually provide more headroom with the same power amplifier complement than a system using high-level passive crossovers. This term "headroom" deserves some consideration. Program material (music or speech) is made up of many different frequencies and their harmonics. Most music, especially popular music, is bass heavy; that is, the low frequency material contains much more energy than the high frequency material. When both high and low frequency material, such as a voice and a bass guitar, are present in a program, the high-energy bass frequencies can "use up" most of the power available from the power amplifier leaving little power for the high frequencies. The result can be severe clipping (distortion) of the high frequency material. In the bi-amplified system, the high frequency material can be routed to its own power amplifier, which minimizes the clipping problem. This results in an effective increase in headroom that is **greater** than would be obtained by simply using a single larger power amplifier.

3

CS-400 PATCH PANEL (STEREO MODE) WITH CROSSOVER AND INPUT TRANSFORMER MODULES

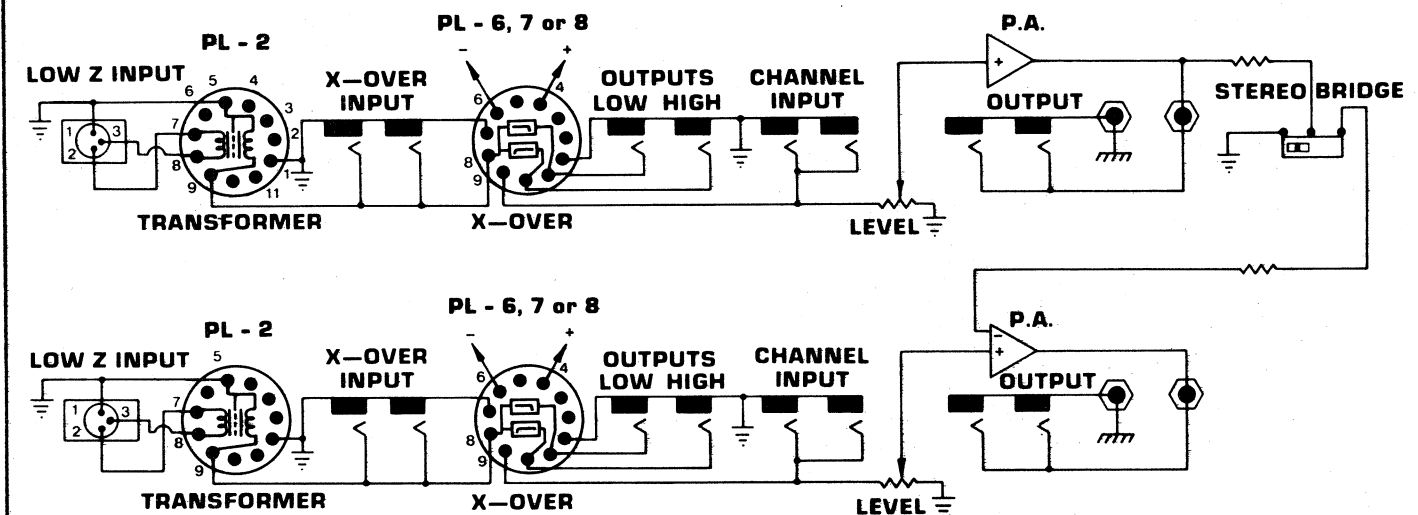

Referring to Diagram 3, crossover networks (PL-6™, -7™, or -8™) are shown plugged into both crossover accessory sockets (8) and transformer modules (PL-2's™) are plugged into both transformer accessory sockets (6). This configuration now has the makings of a complete stereo, balanced bi-amp system. The only thing required is an additional stereo power amplifier which, together with the existing dual power amp sections of the CS-400™, make up the four independent power amplifiers required for a **stereo** bi-amplification system. You will notice from the diagram that when the crossover networks were substituted for the jumpers, the power amp input connections were disconnected from the crossover circuit. In order to complete the system, external patching must be accomplished using shielded patch cords.

As per previous discussion, bi-amplification systems generally require more power for the low frequency system than the high frequency system. In fact, an often used combination is a ratio of two-to-one (twice as much for the lows as for the highs). Such a system can be achieved using a Peavey CS-800™ stereo power amp for the two low frequency channels and the Peavey CS-400™ for the two high frequency channels. This system can be realized by patching the high outs (10) to the inputs of the CS-400™ and by patching the low outs of the crossover network (9) to the inputs of the CS-800™. Four shielded patch cords are required in this configuration. Care must be taken to connect the proper speaker system components to the correct power amp outputs. A diagram is included showing all connections. It is recommended that all connections be completed and double checked before applying power. **Wrong connections could result in loudspeaker damage.** Always remember the power amplifiers should be switched on to A.C. power last in the chain of audio equipment, and only then with level controls at "0." Then gradually increase levels to check connections and make sure at low sound pressure levels that the system (especially bi-amped situations) has proper routing of high's and low's to respective amps, horns, and bass enclosures.

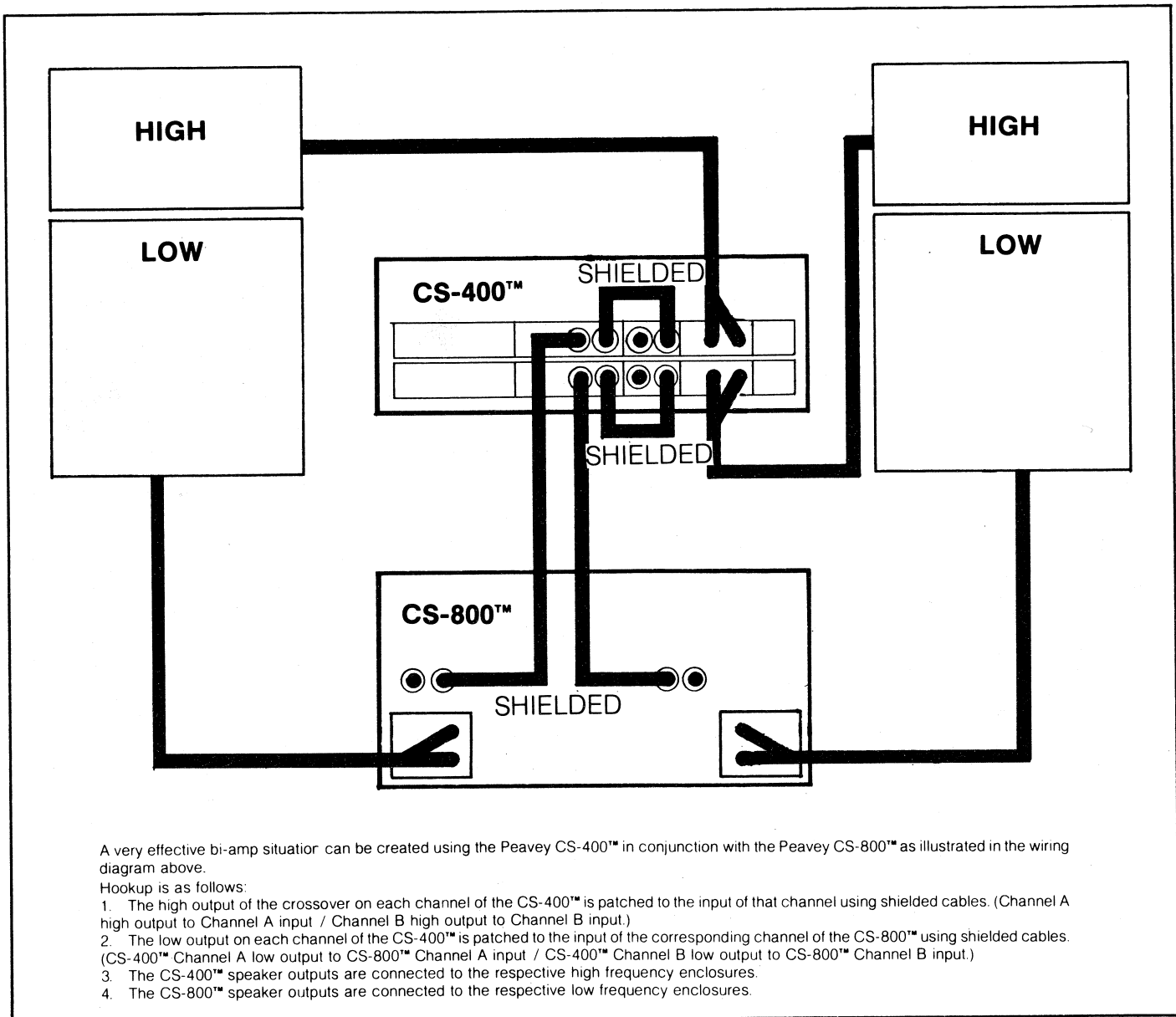

The use of the DDT® compression system adds a new dimension to a total bi-amp system. Since the low frequency power amp and the high frequency power amp each have their own "Distortion Detection Technique" circuitry and are completely independent, when signal conditions exist which could cause clipping in the low frequency power amp, the DDT® system will simply limit that portion of the total sound system. This will in no way affect the high portion of the bi-amp system and it is free to increase in level until it, too, runs into clipping. Then, at that point, the high frequency system will also go into compression. This is a very effective two-level compression system and will yield a sound pressure level unmatched by conventional broad-band compression techniques.

Several comments must be made:

Only **one** crossover module is required for a **monaural** bi-amp system.

The outputs of the crossover can drive several power amp inputs. Parallel input jacks can be used to "daisy chain" to additional power amps for either the low or high frequency systems.

The transformer module can be removed and the jumpers reinstalled if a balanced input is not required for the crossover network. The XLR connector is now unbalanced as per previous discussion. If phone plug inputs to the crossover network are required, parallel crossover input jacks (7) are provided. In addition, these jacks can be used to patch out full range signals to the other amplifier/speaker systems.

Care must be taken to **never remove the crossover network** or replace it **with the CS-400 power switch on**. The circuit used in the crossover network receives bi-polar power through the socket, and removal or replacement could cause severe transients which can destroy the speakers. Always be sure the mode switch is in the stereo position before operating the system. The individual volume controls on each channel play a very important part in the use of this crossover network. As such, they represent a signal loss when they are operated at any setting other than full clockwise. Certain speaker systems may require more signal on the low end than on the high end and consequently, a system balance can be accomplished by reducing the high-pass level. Generally speaking, however, the two controls should be operated at approximately the same setting and at least a setting of "7" or greater. Failure to observe this minimum setting could result in distortion due to the inability of some signal sources to provide an adequate voltage swing to the crossover network.

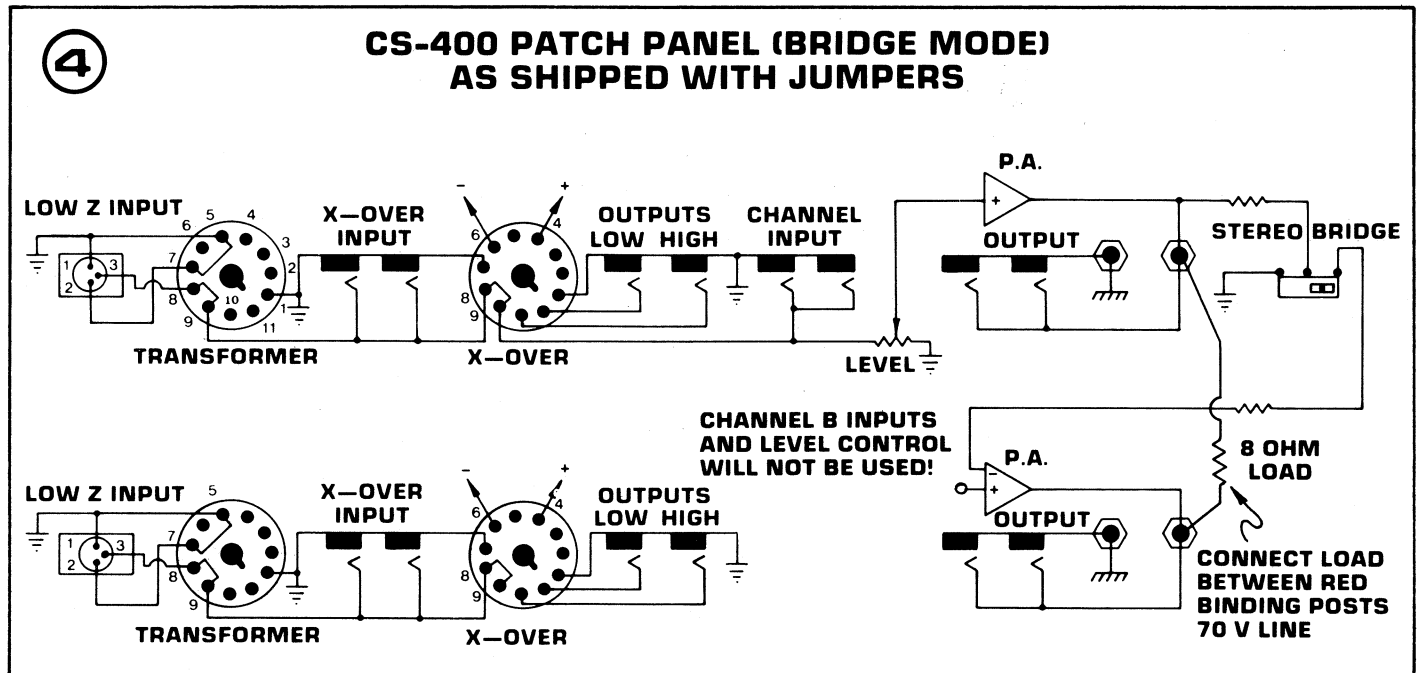

Occasionally a 70-volt line is required for a sound distribution system or in public address applications. This technique is generally used in systems which have long cable runs between the power amplifier and the speaker systems. It is almost universal in distributed systems. The CS-400™ can supply 70 volts RMS directly without matching transformers by using the bridge mode as shown in Diagram 4. The bridge mode for stereo amplifiers is often misunderstood as to the actual operation and usage. In basic terms, when a two-channel amplifier is operated in the bridge mode, the system is converted to a **single-channel** unit with a power capability equal to the **sum of both channels** operated continuously at a **load impedance** equal to **twice** that of one channel. This is accomplished by providing an input to one channel, placing the mode switch in the bridge position and connecting the load between the red binding post of each channel. In the case of the CS-400™, the active input is Channel A, the output power is 400 watts, and the matched load is 8 ohms.

It must be pointed out that for proper operation, **both** wires of the output must "float" above ground. Since Channel A is the active channel, the Channel A patch panel can be used to provide a balanced input through the use of a PL-2™. The Channel B volume should be set at "0" for lowest noise. Overall system volume is controlled by the Channel A volume control.

Crossover modules can be used if desired since they are totally isolated from the power amp inputs but remember the CS-400™ power section is effectively a single-channel amplifier in the bridge mode.

As you can see, the CS-400™ is a very flexible amplifier. We highly recommend that you become thoroughly familiar with every aspect of operation before connecting any speaker system to it. Pay particular attention to the functions of the patch panel and the load impedance.

CS-400™ SPECS

FREQUENCY RESPONSE:

+0, -1.0 dB, 5 Hz to 40 KHz @ 1.0 watt, 4 ohms

POWER @ CLIPPING:

Typically: (1.0% THD, 1.0 KHz, 120 VAC line)

150 watts RMS into 8 ohms

260 watts RMS into 4 ohms

150 watts RMS into 2 ohms

RATED POWER:

200 watts RMS into 4 ohms

(Both channels driven)

400 watts RMS into 8 ohms

(In Bridge Mode)

INTERMODULATION DISTORTION:

Less than 0.1% from 20 mW to 200 watts RMS into 4 ohms.

Typically below .05%

TOTAL HARMONIC DISTORTION:

Less than 0.1% from 20 mW to 200 watts RMS, 20 Hz to 20

KHz into 4 ohms, Typically below .04%

SLEW RATE:

20 V per micro second

HUM & NOISE:

95 dB below 200 watts RMS output (20 Hz to 20 KHz)

LOAD IMPEDANCE:

4 ohms or greater (stable into any load configuration)

DAMPING FACTOR:

Greater than 100 (1.0 KHz, 4 ohms)

INPUT SENSITIVITY:

1.0 volts RMS for 200 watts, 4 ohms

INPUT IMPEDANCE:

50 K ohms (input overload protection)

LOAD PROTECTION:

Short, mismatch, open circuit proof; voltage/current limiting instantaneous with no thumps or cutout

SPEAKER PROTECTION:

Instantaneous crowbar circuit clamps the output upon advent of amplifier failure.

POWER CONSUMPTION:

900 watts, 120 VAC, 50/60 Hz (domestic model)

DIMENSIONS:

19" W x 5 1/4" H x 14" D

DANGER

EXPOSURE TO EXTREMELY HIGH NOISE LEVELS MAY CAUSE A PERMANENT HEARING LOSS. INDIVIDUALS VARY CONSIDERABLY IN SUSCEPTIBILITY TO NOISE INDUCED HEARING LOSS, BUT NEARLY EVERYONE WILL LOSE SOME HEARING IF EXPOSED TO SUFFICIENTLY INTENSE NOISE FOR A SUFFICIENT TIME.

THE U.S. GOVERNMENT'S OCCUPATIONAL SAFETY AND HEALTH ADMINISTRATION (OSHA) HAS SPECIFIED THE FOLLOWING PERMISSIBLE NOISE LEVEL EXPOSURES:

DURATION PER DAY IN HOURS	SOUND LEVEL dBA, SLOW RESPONSE
8	90
6	92
4	95
3	97
2	100
1 1/2	102
1	105
1/2	110
1/4 or less	115

ACCORDING TO OSHA, ANY EXPOSURE IN EXCESS OF THE ABOVE PERMISSIBLE LIMITS COULD RESULT IN SOME HEARING LOSS.

EAR PLUGS OR PROTECTORS IN THE EAR CANALS OR OVER THE EARS MUST BE WORN WHEN OPERATING THIS AMPLIFICATION SYSTEM IN ORDER TO PREVENT A PERMANENT HEARING LOSS IF EXPOSURE IS IN EXCESS OF THE LIMITS AS SET FORTH ABOVE. TO INSURE AGAINST POTENTIALLY DANGEROUS EXPOSURE TO HIGH SOUND PRESSURE LEVELS, IT IS RECOMMENDED THAT ALL PERSONS EXPOSED TO EQUIPMENT CAPABLE OF PRODUCING HIGH SOUND PRESSURE LEVELS SUCH AS THIS AMPLIFICATION SYSTEM BE PROTECTED BY HEARING PROTECTORS WHILE THIS UNIT IS IN OPERATION.

CAUTION

THIS AMPLIFIER HAS BEEN DESIGNED AND CONSTRUCTED TO PROVIDE ADEQUATE POWER RESERVE FOR PLAYING MODERN MUSIC WHICH MAY REQUIRE OCCASIONAL PEAK POWER. TO HANDLE OCCASIONAL PEAK POWER, ADEQUATE POWER "HEADROOM" HAS BEEN DESIGNED INTO THIS SYSTEM. EXTENDED OPERATION AT ABSOLUTE MAXIMUM POWER LEVELS IS NOT RECOMMENDED SINCE THIS COULD DAMAGE THE ASSOCIATED LOUDSPEAKER SYSTEM. PLEASE BE AWARE THAT MAXIMUM POWER CAN BE OBTAINED WITH VERY LOW SETTINGS OF THE GAIN CONTROLS IF THE INPUT SIGNAL IS VERY STRONG.

1. Read all safety and operating instructions before using this product.
2. All safety and operating instructions should be retained for future reference.
3. Obey all cautions in the operating instructions and on the back of the unit.
4. All operating instructions should be followed.
5. This product should not be used near water, i.e. a bathtub, sink, swimming pool, wet basement, etc.
6. This product should be located so that its position does not interfere with its proper ventilation. It should not be placed flat against a wall or placed in a built-in enclosure that will impede the flow of cooling air.
7. This product should not be placed near a source of heat such as a stove, heater, radiator or another heat producing amplifier.
8. Connect only to a power supply of the type marked on the unit adjacent to the power supply cord.
9. Never break off the ground pin on the power supply cord. For more information on grounding write for our free booklet "Shock Hazard and Grounding."
10. Power supply cords should always be handled carefully. Never walk or place equipment on power supply cords. Periodically check cords for cuts or signs of stress, especially at the plug and the point where the cord exits the unit.
11. The power supply cord should be unplugged when the unit is to be unused for long periods of time.
12. Metal parts can be cleaned with a damp rag. The vinyl covering used on some units can be cleaned with a damp rag, or an ammonia based household cleaner if necessary.
13. Care should be taken so that objects do not fall and liquids are not spilled into the unit through the ventilation holes or any other openings.
14. This unit should be checked by a qualified service technician if:
 - A. The power supply cord or plug has been damaged.
 - B. Anything has fallen or been spilled into the unit.
 - C. The unit does not operate correctly.
 - D. The unit has been dropped or the enclosure damaged.
15. The user should not attempt to service this equipment. All service work should be done by a qualified service technician.

Due to our efforts for constant improvement, specifications and features listed herein are subject to change without notice.



PEAVEY ELECTRONICS CORP.

711 A Street / Meridian, MS 39301 / U.S.A.

80370040 5/82

© 1982
Printed in U.S.A.