



C2924M-QS (4/05)

CCC1390H Series Camera

Quick Start Guide

This quick start guide describes how to install and configure the CCC1390H Series camera in most applications. It contains a representation of the setup menus to help you locate and change specific settings.

Refer to the enclosed CD for the following documentation:

- Installation/Operation manual: INSTALL.PDF
- Quick Start Guide: QSG.PDF
- Important Safety Instructions: SAFETY.PDF

MODELS

CCC1390H-6 1/3-inch high resolution day/night, WDR, CCD camera, 24 VAC or 12 VDC, NTSC format

CCC1390H-6X 1/3-inch high resolution day/night, WDR, CCD camera, 24 VAC or 12 VDC, PAL format

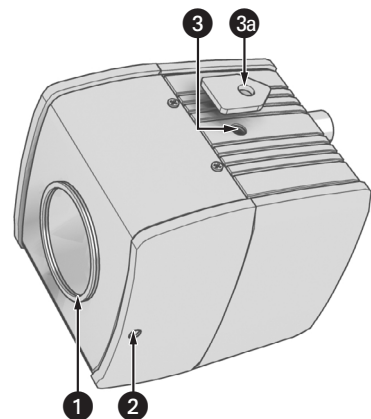

- 1 Lens Mount
- 2 Back Focus Locking Screw
- 3 Camera Mount and 3a Adapter
- 4 Serial Terminating Switch
- 5 Auto Iris Lens Connector

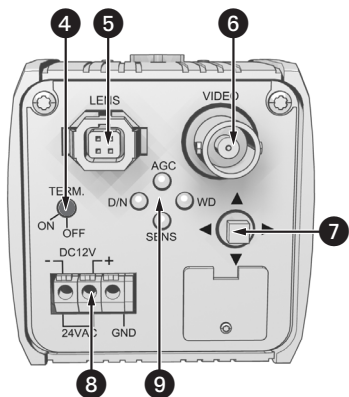

- 6 Video Output Connector
- 7 Setup Button
- 8 Power Terminal Strip
- 9 Indicators

SETUP MENUS

Use the setup menu to customize the camera settings. Refer to the setup menus as shown on this and the opposite page.

MAIN MENU	
PROFILES	>
EXPOSURE SETTINGS	>
FUNCTION SETTINGS	>
CAMERA SETUP	>
AI AUTO ADJUSTMENT	>
PIXEL CORRECTION	>
SYSTEM INFORMATION	>
BACK	EXIT

CAMERA SETUP	
ADDRESS	> 1
COM SPEED	> 4800
LED	> ON
SWITCH	> ON
BACK	EXIT

PROFILES	
ACTIVE	> STANDARD
SAVE AS	> CUSTOM
*DEFAULT	STANDARD
BACK	EXIT

AI AUTO ADJUSTMENT	
OK	CANCEL

EXPOSURE SETTINGS	
AUTO EXPOSURE	> NORMAL
VIDEO LEVEL	> 0
FLICKERLESS	> OFF
AGC	> ON
DSS(SENS)	> 4
DAY & NIGHT	> COLOR
D&N DETECTION	>
D&N FILTER LIMIT	>
BACK	EXIT

SYSTEM INFORMATION	
FIRMWARE VERSION	1.0
OSD VERSION	1.0
RESTORE FACTORY SETTINGS	>
BACK	EXIT

FUNCTION SETTINGS	
LINE SYNC	>
WHITE BALANCE	> AUTO
MANUAL RED/BLUE	>
GAMMA	> 60%(NORM)
SHARPNESS	>
E-ZOOM	>
MASKING	>
TITLE	>
BACK	EXIT

RESTORE FACTORY SETTINGS	
OK	CANCEL

LINE SYNC LINE SYNC > AUTO V-PHASE ADJ >	V-PHASE ADJ PHASE VALUE = 45
BACK EXIT	
MANUAL RED/BLUE RED GAIN > -1 BLUE GAIN > -2 RED HUE > 1 BLUE HUE > 1	SHARPNESS APERTURE GAIN > -1
BACK EXIT	BACK EXIT
E-ZOOM ZOOM > OFF POSITION >	POSITION
BACK EXIT	
MASKING MASK > OFF MASK EDIT > MASK ERASE >	MASK SETTING
BACK EXIT	
TITLE TITLE > OFF EDIT TITLE >	EDIT TITLE ABCDEFGHIJKLM NOPQRSTUVWXYZ abcdefghijklm nopqrstuvwxyz 0123456789-/ BACK BS
BACK EXIT	

LENS

The CCC1390H Series camera supports both manual and DC-drive auto iris lenses, either fixed focal length or varifocal. It automatically senses an auto iris lens as soon as you plug in the connector. The camera has a standard CS-mount that can accept a C-mount lens with a PCMA40 lens adapter.

To mount the lens onto the camera:

1. Use clean, compressed air or a clean, dry lens cloth to make sure there is no dust or other foreign matter between the lens and the camera imager.
2. **C-mount lens:** Screw the adapter onto the lens.
3. Screw the lens onto the lens mount.
4. **DC-drive auto iris lens:** Connect the four-pin connector from the lens to the connector on the back of the camera.

MOUNT

The CCC1390H Series camera can be mounted from either the top or bottom, depending on the type of camera mount used in your installation. Use a standard 1/4-20 screw. The maximum thread depth (top) is 0.188 inches (4.7 mm). To extend the thread depth (top) to 0.25 inches (6.4 mm), use the camera mount spacer (supplied). The maximum thread depth (bottom) is 0.25 inches (6.4 mm).

ELECTRICAL

Power

Connect 12 VDC or 24 VAC power to the three-pin terminal strip on the back of the camera. Use a Class 2 isolated power source for the CCC1390H camera that can supply 12 VDC $\pm 15\%$ or 24 VAC $\pm 15\%$, 50/60 Hz. Maximum power consumption is about 3.5 watts.

Video

Connect a coaxial video cable to the BNC connector on the back of the camera.

External Control

For serial control, install the control connector (refer to *Connecting External Control* in the Installation/Operation manual for more information).

ACCESSING THE SETUP MENUS

Use the five-position button on the rear panel to access and navigate the setup menus. The following table lists the button presses for each menu action.

MENU ACTION	BUTTON ACTION
Enter setup menus.	Long center press
Move up or down in menu or item options.	Up or down press
Move right or left in menu.	Right or left press
Select menu or item.	Short center press
Save setting and exit to menu.	Short center press

NOTE: After you customize any aspect of the CCC1390H Series camera, be sure to save your custom settings. (Refer to *Profiles* in the Installation/Operation manual for information about saving custom settings.)

LENS FOCUS

After mounting the lens, you must focus your CCC1390H Series camera. You will adjust both the back focus (on the camera) and the fine focus (on the lens).

NOTE: The back focus has already been adjusted using a standard CS-mount lens. However, you might need to adjust it again to match the mounted lens.

1. **Auto iris only:** Cover the auto iris lens with a suitable neutral density (ND) filter. This opens the iris fully. For best results, use an ND3 filter.
2. **Manual iris only:** Open the iris completely. The figure shows the manual iris, varifocal, and lens focus locking screws for a sample lens. Refer to your lens documentation for more information.
3. If necessary, enable Automatic Gain Control (AGC) on the EXPOSURE SETTINGS menu. AGC is enabled by default.
 - a. Display the EXPOSURE SETTINGS menu.
 - b. Change AGC to ON.
 - c. Select EXIT to save the AGC setting.
4. Aim the camera at the farthest object in the field of view. Make sure it is at least 6.5 ft (2 m) away.
5. **Fixed focal length lens only:**
 - a. Set the lens focal length to far (∞).
 - b. Adjust the back focus:
 - (1) Use a 1.5-mm Allen wrench to loosen the back focus locking screw.
 - (2) Turn the lens until the image is focused.
 - (3) Tighten the back focus locking screw clockwise.

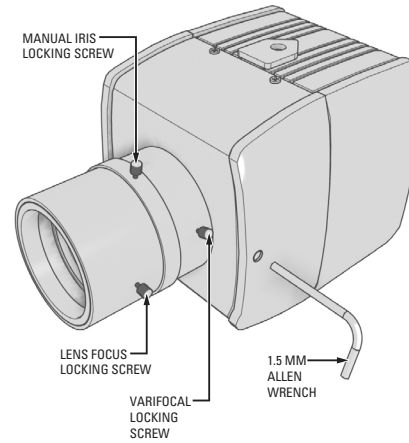

WARNING: Do not over-tighten the back focus locking screw because you may damage the camera.

Back focus is a coarse adjustment. You will make the fine focus adjustment in the next step.

- c. Adjust the lens focus to achieve the best fine focus.

6. Varifocal lens only:

- a. Set the varifocal to wide (W) and the lens focal length to far (∞).
- b. Adjust the back focus:
 - (1) Use a 1.5-mm Allen wrench to loosen the back focus locking screw.
 - (2) Turn the lens until the image is focused.
 - (3) Tighten the back focus locking screw clockwise.

WARNING: Do not over-tighten the back focus locking screw because you may damage the camera.

Back focus is a coarse adjustment. You will make the fine focus adjustment in steps c and d.

- c. Move the varifocal locking screw up or down to set the field of view.
 - d. Adjust the lens focus to achieve the best fine focus.
 - e. Repeat steps c and d until the focus is correct.
7. **Manual iris only:** Adjust the iris for the best picture quality. The largest aperture gives the best light sensitivity; the smallest aperture gives the greatest depth of field.
 8. Tighten all lens locking screws.

NOTE: When tightening the lens locking screws, do not over-turn or force any screw.

9. **Auto iris only:** Remove the ND filter.
10. If necessary, disable AGC:
 - a. Display the EXPOSURE SETTINGS menu.
 - b. Change AGC to OFF.
 - c. Select EXIT to save the AGC setting.
11. **Auto iris only:** Perform the auto iris lens adjustment procedure (refer to *Auto Iris Lens Adjustment* in the Installation/Operation manual for more information).
12. As soon as you finish customizing this and all other camera settings, save your custom settings into the CUSTOM profile. This protects them in case the camera loses power or must be restarted (refer to *Profiles* in the Installation/Operation manual for more information).

REVISION HISTORY

Manual #	Date	Comments
C2924M-QS	4/05	Original version.

Pelco and the Pelco logo are registered trademarks of Pelco.

©Copyright 2005, Pelco. All rights reserved.

Worldwide Headquarters • 3500 Pelco Way • Clovis, California 93612 USA • www.pelco.com
USA & Canada • Tel: 800/289-9100 • Fax: 800/289-9150
International • Tel: 1-559/292-1981 • Fax: 1-559/348-1120